

Brief Operating Instructions Nivotester FTL325N, single- channel

Vibronic

Level detector with NAMUR input for connecting
any NAMUR sensor



These Instructions are Brief Operating Instructions; they are not a substitute for the Operating Instructions pertaining to the device.

Detailed information about the device can be found in the Operating Instructions and the other documentation:

Available for all device versions via:

- Internet: www.endress.com/deviceviewer
- Smart phone/tablet: *Endress+Hauser Operations App*

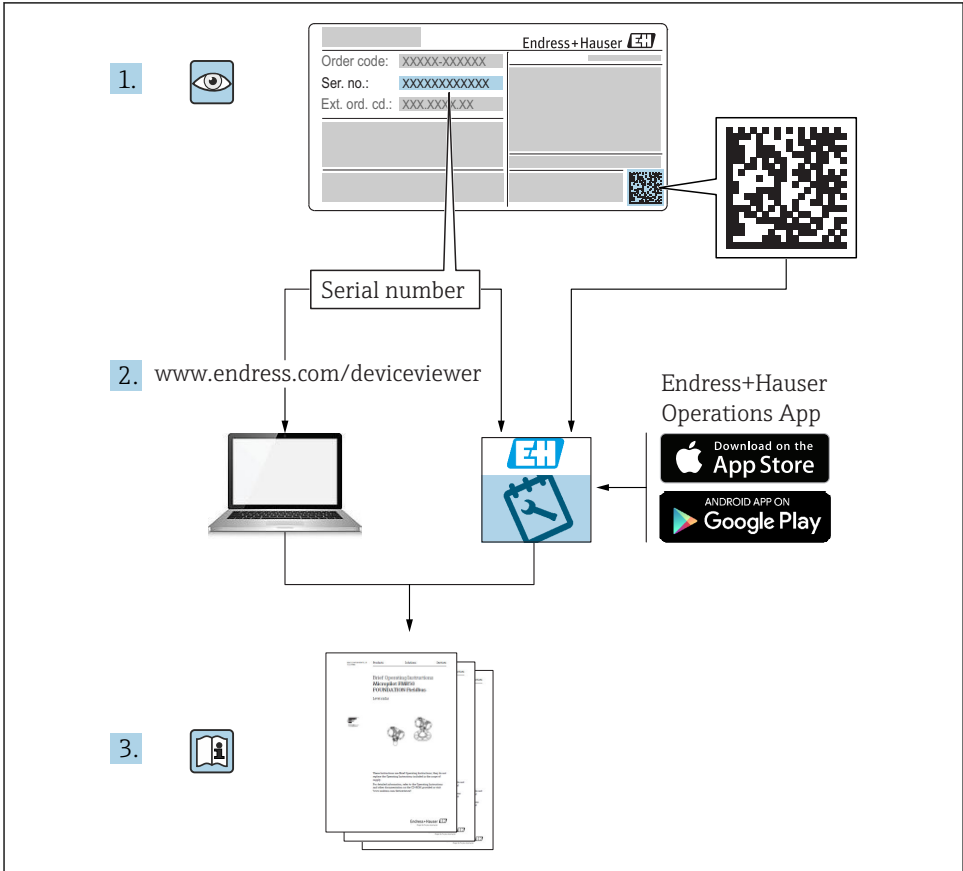

A0023555

Table of contents

1	About this document	3
1.1	Symbols	3
2	Basic safety instructions	5
2.1	Requirements for the personnel	5
2.2	Designated use	5
2.3	Workplace safety	5
2.4	Operational safety	5
2.5	Product safety	6
3	Incoming acceptance and product identification	6
3.1	Incoming acceptance	6
3.2	Product identification	6
3.3	Storage, transport	7
4	Installation	8
4.1	Mounting conditions	8
4.2	Mounting the measuring device	9
4.3	Post-installation check	11
5	Electrical connection	12
5.1	Connection conditions	12
5.2	Connecting the measuring device	12
5.3	Special connection instructions	14
5.4	Ensuring the degree of protection	14
5.5	Post-connection check	14
6	Operation options	15
6.1	Operation concept	15
6.2	Opening the front panel	15
6.3	Display elements	16
6.4	Operating elements	17
7	Commissioning	17
7.1	Function check	17
7.2	Setting the functions	17
7.3	Function testing of secondary equipment	21

1 About this document

1.1 Symbols

1.1.1 Safety symbols



This symbol alerts you to a dangerous situation. Failure to avoid this situation will result in serious or fatal injury.



This symbol alerts you to a dangerous situation. Failure to avoid this situation can result in serious or fatal injury.

⚠ CAUTION

This symbol alerts you to a dangerous situation. Failure to avoid this situation can result in minor or medium injury.

NOTICE

This symbol contains information on procedures and other facts which do not result in personal injury.

1.1.2 Electrical symbols

 Ground connection

Grounded clamp, which is grounded via a grounding system.

 Protective earth (PE)

Ground terminals, which must be grounded prior to establishing any other connections. The ground terminals are located on the inside and outside of the device.

 Output

 Input

 Fault

 No fault

 Limit signal

Light emitting diodes (LED)

 LED not lit

 LED lit

 LED flashing

1.1.3 Symbols for certain types of information and graphics

 Tip

Indicates additional information

 Reference to documentation

 Reference to another section

1, **2**, **3** Series of steps

A, **B**, **C** ... View

 Hazardous area

 Safe area (non-hazardous area)

2 Basic safety instructions

2.1 Requirements for the personnel

The personnel must fulfill the following requirements to carry out their tasks, e. g. commissioning and maintenance:

- ▶ Trained specialists must have a qualification that is relevant to the specific function and task.
- ▶ Must be authorized by the plant owner/operator.
- ▶ Must be familiar with national regulations.
- ▶ Must have read and understood the instructions in the manual and supplementary documentation.
- ▶ Personnel must follow instructions and comply with general policies.

2.2 Designated use

- The Nivotester FTL325N with intrinsically safe NAMUR inputs (IEC/EN 60947-5-6) must be connected only to appropriate sensors.
- The device may be dangerous if used incorrectly.
- Use only tools that have been insulated against ground
- Use only original parts

2.2.1 Incorrect use

The manufacturer is not liable for damage caused by improper or non-designated use.

Deviating application conditions may affect the level of protection. The correct functioning of the device cannot be guaranteed.

2.3 Workplace safety

For work on and with the device:

- ▶ Wear the required protective equipment according to federal/national regulations.

2.4 Operational safety

Risk of injury!

- ▶ Operate the device only if it is in proper technical condition, free from errors and faults.
- ▶ The operator is responsible for ensuring failure-free operation of the device.

Modifications to the device

Unauthorized modifications to the device are not permitted and can lead to unforeseeable dangers.

- ▶ If, despite this, modifications are required, consult with Endress+Hauser.

Repair

To ensure continued operational safety and reliability:

- ▶ Only perform repair work on the device if this is expressly permitted.
- ▶ Observe federal/national regulations pertaining to the repair of an electrical device.
- ▶ Use original spare parts and accessories from Endress+Hauser only.

2.5 Product safety

This device has been constructed and tested to state-of-the-art operational safety standards and in accordance with good engineering practice. The device left the factory in a safe operating condition.

2.5.1 CE mark

The device meets the legal requirements of the applicable EU Directives. These are listed in the corresponding EU Declaration of Conformity along with the standards applied. Endress+Hauser confirms successful testing of the device by affixing to it the CE mark.

2.5.2 EAC conformity

The device meets the legal requirements of the applicable EAC Directives. These are listed in the corresponding EAC Declaration of Conformity along with the standards applied. Endress+Hauser confirms successful testing of the device by affixing to it the EAC mark.

3 Incoming acceptance and product identification

3.1 Incoming acceptance

Check the following during goods acceptance:

- Are the order codes on the delivery note and the product sticker identical?
- Are the goods undamaged?
- Do the nameplate data match the ordering information on the delivery note?
- If necessary (see nameplate), are the Safety Instructions, e. g. XA, provided?



If one of these conditions is not satisfied, contact your Sales Center.

3.2 Product identification

Nameplate data on the device

- ▶ Enter the serial number from the nameplates in the *W@M Device Viewer* (www.endress.com/deviceviewer)
 - ↳ All the information about the measuring device and all associated Technical Documentation are displayed.
- ▶ Enter the serial number from the nameplate in the *Endress+Hauser Operations app*.
 - ↳ All the information about the measuring device and all associated Technical Documentation are displayed.

3.2.1 Nameplate

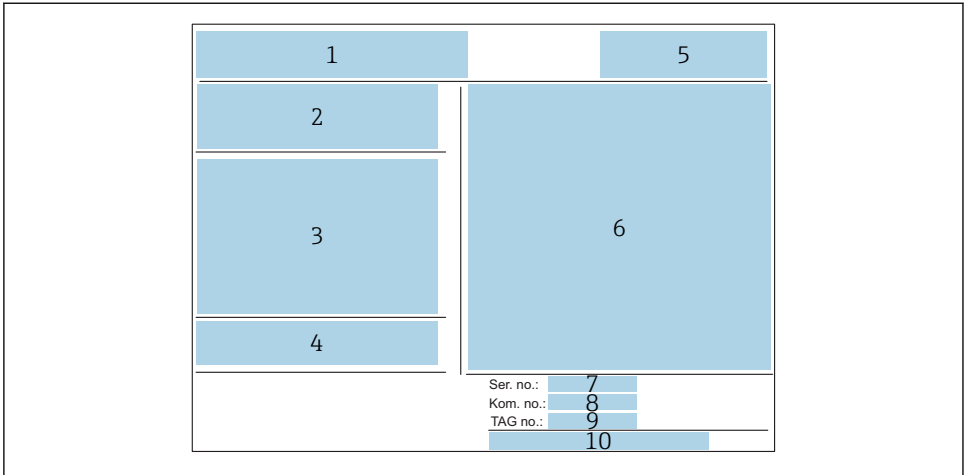

A0039180

1 Nameplate

- 1 *Manufacturer's logo, product name*
- 2 *Supply voltage*
- 3 *Electrical connection*
- 4 *Temperature specifications and reference to additional safety-related documentation (only for certified device versions)*
- 5 *Reference to certifications*
- 6 *Identification in accordance with Directive 94/9/EC and identification of type of explosion protection (only for certified device versions)*
- 7 *Serial number*
- 8 *Kom. number*
- 9 *TAG number*
- 10 *Manufacturer's address*

3.2.2 Manufacturer address

Endress+Hauser SE+Co. KG
 Hauptstraße 1
 79689 Maulburg, Germany

Address of the manufacturing plant: See nameplate.

3.3 Storage, transport

- Pack the device so that it is protected against impact
 The original packaging offers the best protection
- Permitted storage temperature: -20 to +85 °C (-4 to +185 °F)

3.3.1 Transporting the product to the measuring point

Transport the measuring device to the measuring point in the original packaging.

4 Installation

4.1 Mounting conditions

- If using outside the hazardous area, mount the device in a cabinet.
- Mount the device so that it is protected against weather and impact.
If operating outdoors and in warmer climates, avoid direct sunlight.
Protective housing (IP65) is available for up to four single-channel Nivotester devices or two 3-channel Nivotester devices.

4.2 Mounting the measuring device

4.2.1 Horizontal orientation

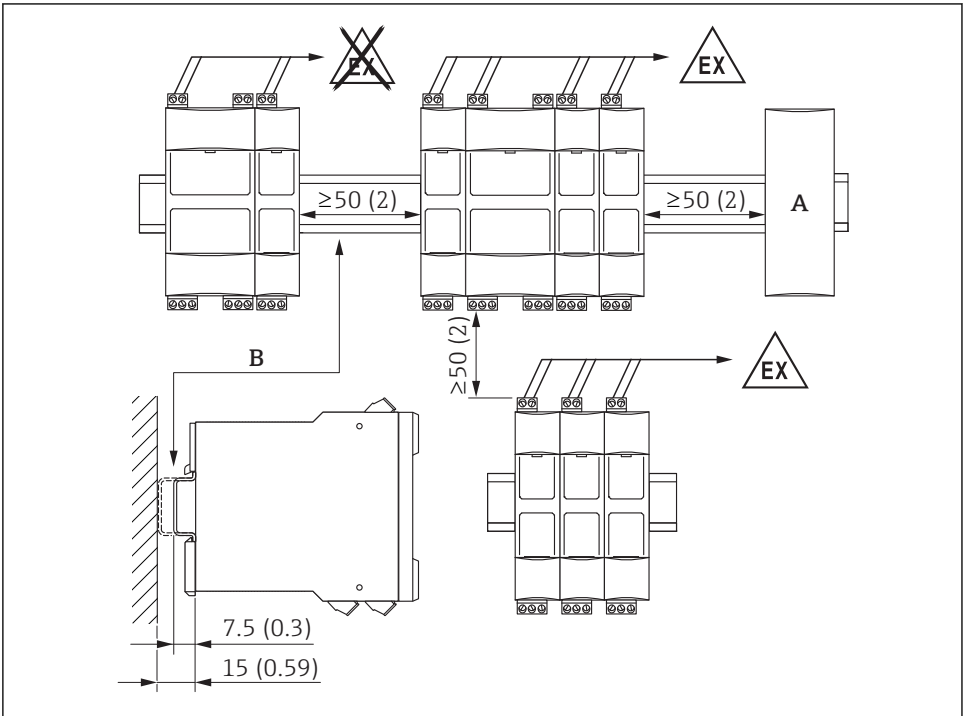

A0026303

2 Minimum spacing, horizontal orientation. Unit of measurement mm (in)

A Connection of another device type

B DIN rail in accordance with EN 60715 TH35-7.5/15



A horizontal installation ensures better dissipation of heat than a vertical orientation.

4.2.2 Vertical orientation

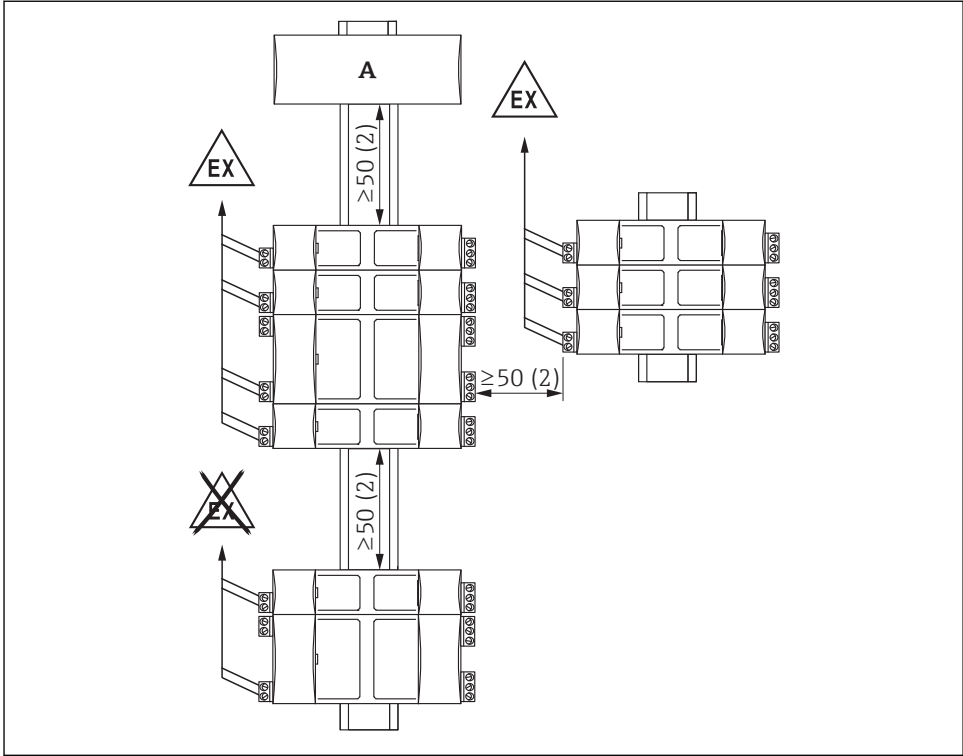

A0026420

3 Minimum spacing, vertical orientation. Unit of measurement mm (in)

A Connection of another device type

4.2.3 Mounting the device

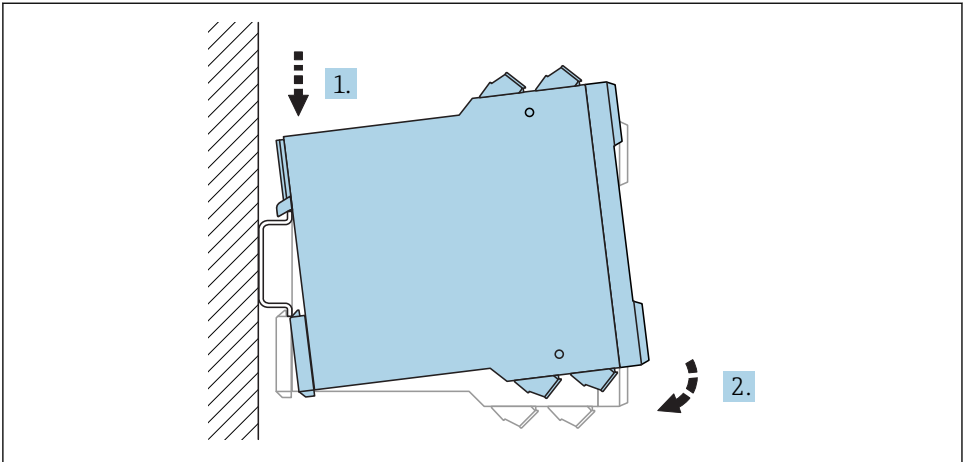

A0039139

4 Mounting; DIN rail as per EN 60715 TH35-7.5/EN 60715 TH35-15

4.2.4 Removing the device

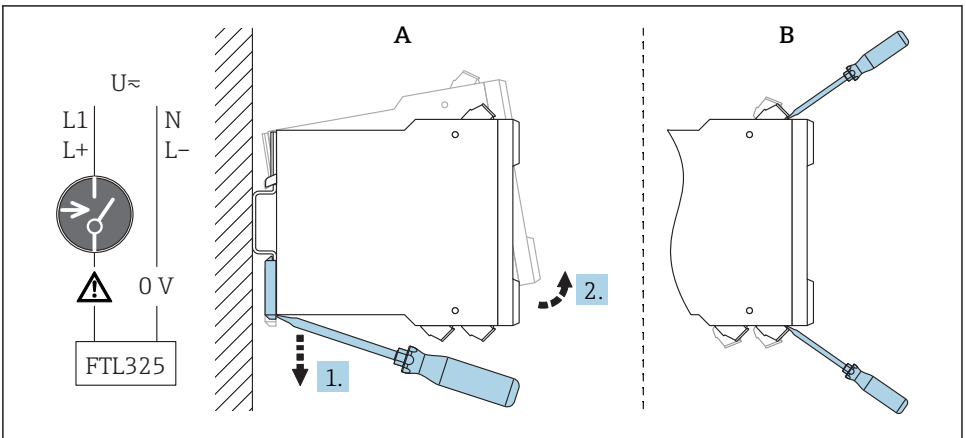

A0039140

5 Removing

A Remove from DIN rail.

B For quick replacement of devices without a cable, remove the terminal strips.

4.3 Post-installation check

Is the measuring device undamaged (visual inspection)?

Does the measuring device conform to the measuring point specifications?

For example:

- Supply voltage
- Ambient temperature range

Are the measuring point number and labeling correct (visual inspection)?

Is the measuring device adequately protected against precipitation and direct sunlight?

5 Electrical connection

5.1 Connection conditions

WARNING

Risk of explosion due to faulty connection.

- ▶ Observe applicable national standards.
- ▶ Comply with the specifications in the Safety Instructions (XA).
- ▶ Check to ensure that the power supply matches the information on the nameplate.
- ▶ Switch off the supply voltage before connecting.
- ▶ When connecting to the public mains, install a mains switch for the device such that it is within easy reach of the device. Mark the power switch as a disconnecter for the device (IEC/EN61010).

5.2 Connecting the measuring device

 The removable terminal blocks are color-coded into intrinsically safe and non-intrinsically safe terminals. This difference helps to ensure safe wiring.

5.2.1 Arrangement of terminals

 Observe the specifications on the nameplate of the device.

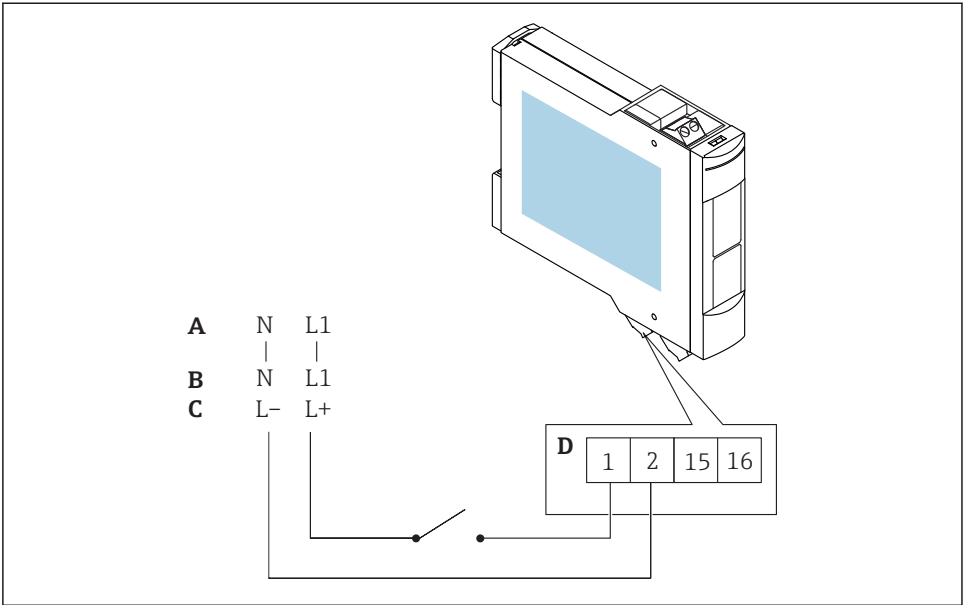

A0039152

6 Arrangement of terminals

A $U \sim 85$ to $253 V_{AC}$, 50/60 Hz

B $U \sim 20$ to $30 V_{AC}$, 50/60 Hz

C $U = 20$ to $60 V_{DC}$

D Max. 1.5 mm^2 (max. AWG 16)

5.2.2 Connecting the sensor

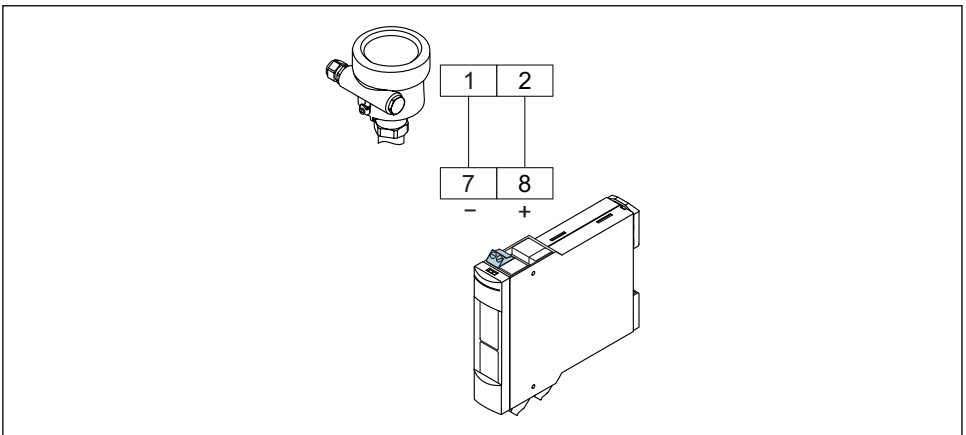

A0039154

7 Connecting the sensor to any NAMUR sensor

Blue terminal blocks at top for hazardous area

- Twin-core connecting cable between the Nivotester and sensor, e. g. commercially available instrument cable or cores in a multi-core cable for measurement purposes
- Use a shielded cable in the event of increased electromagnetic interference, e. g. from machines or radio equipment. Only connect the shield to the grounding terminal in the sensor. Do not connect it to the Nivotester.

 For applications requiring functional safety in accordance with IEC 61508 (SIL), see the Functional Safety Manual. For WHG applications, see the associated WHG documents.

5.2.3 Connecting the signal and control systems

Gray terminal blocks at bottom for the non-hazardous area

Relay function depending on the level and safety mode

If a device with high inductance is connected (e. g. contactor, solenoid valve), a spark arrestor must be installed to protect the relay contact .

5.2.4 Connecting the supply voltage

Green terminal block at bottom

A fuse is integrated into the power supply circuit. An additional fine-wire fuse is not necessary. The Nivotester is equipped with reverse polarity protection.

5.3 Special connection instructions

5.3.1 Connecting the outputs

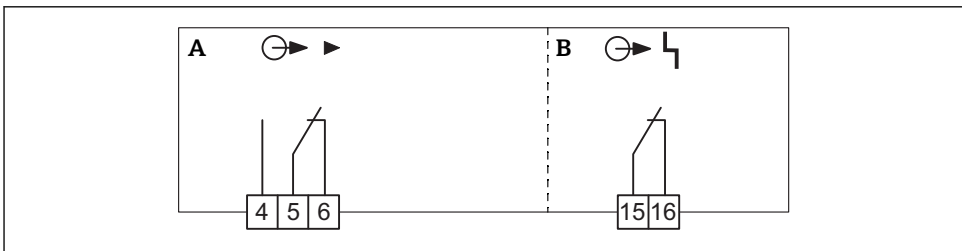

A0039183

8 Connecting the outputs

A Level, limit signal

B Fault, alarm

5.4 Ensuring the degree of protection

- IP20 (as per IEC/EN 60529)
- IK06 (as per IEC/EN 62262)

5.5 Post-connection check

- Is the device or cable undamaged (visual inspection)?

- Do the mounted cables have adequate strain relief?
- Does the supply voltage match the specifications on the nameplate?
- No reverse polarity, is terminal assignment correct?
- Do the cables used comply with the requirements?
- If necessary, has a protective ground connection been established?
- If supply voltage is present, is the device operational and does a screen appear?

6 Operation options

6.1 Operation concept

Onsite configuration with DIL switches behind fold-down front panel.

6.2 Opening the front panel

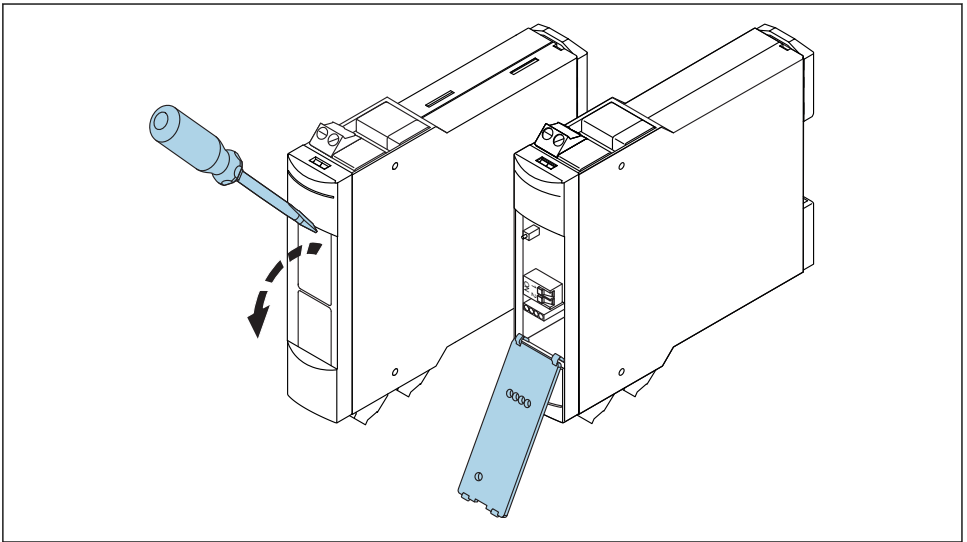

 9 *Opening the front panel*

6.3 Display elements

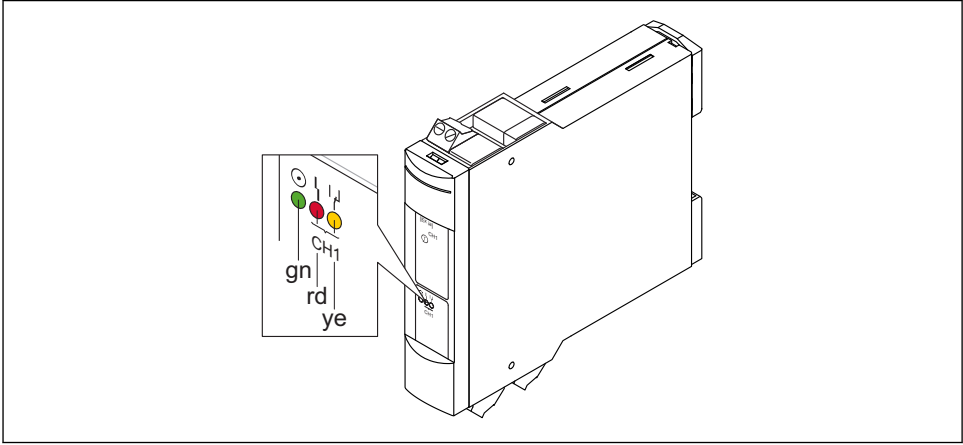

A0039238

10 Display elements, light emitting diodes (LEDs)

- gn* Green LED: ready for operation
- rd* Red LED: fault signaling
- ye* Yellow LED: level relay energized

6.4 Operating elements

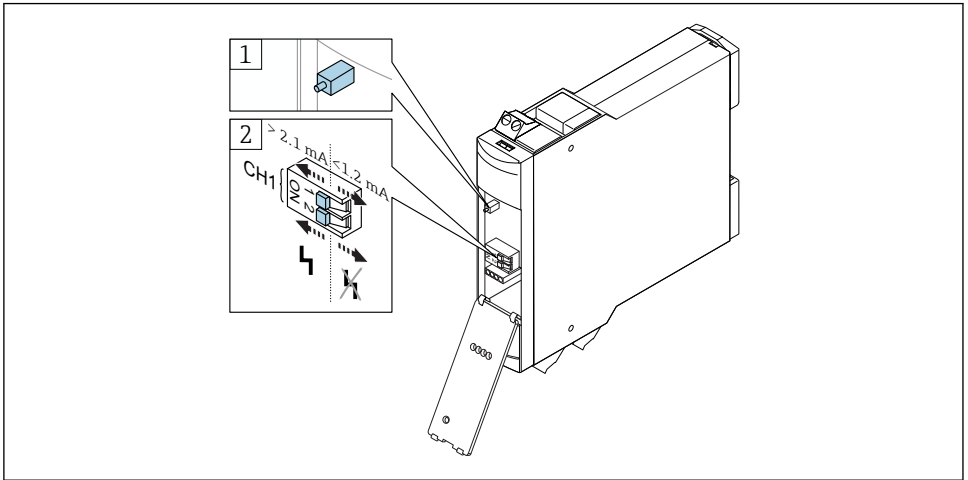

A0039543

11 Operating elements

- 1 Test button, can also be operated when the front panel is closed
- 2 Setting on the electronic insert
- H Error current signal H (High) = 2.1 to 5.5 mA (FEL56)
- L Error current signal L (Low) = 0.4 to 1.2 mA (FEL58, FEL48, FEL68, FEM58, FEI58)

7 Commissioning

7.1 Function check

- Perform installation check.
- Perform function check.

7.2 Setting the functions



See Operating Instructions.

7.2.1 Pay attention to the switch position.

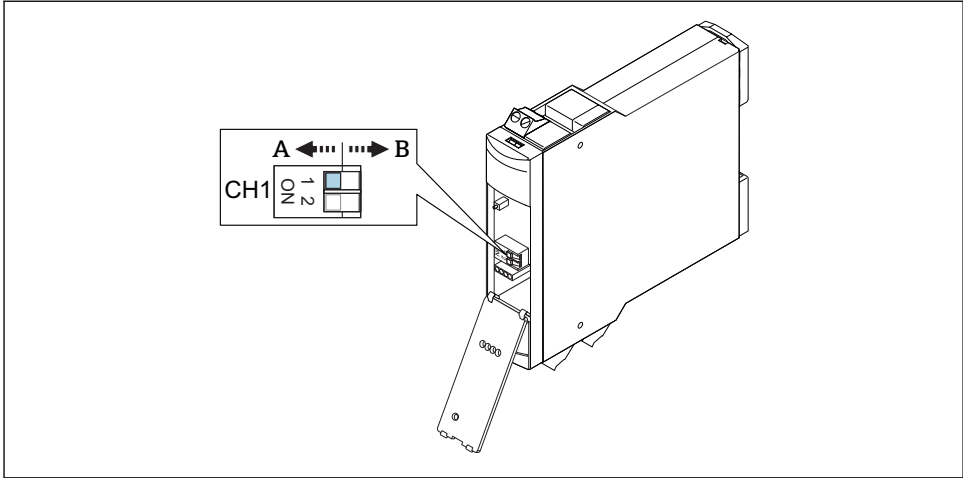

A0039551

12 Switch position on switching unit

A Error current signal H (High) > 2.1 mA (FEL56)

B Error current signal L (Low) < 1.2 mA (FEL58, FEL48, FEL68, FEM58, FEI58)

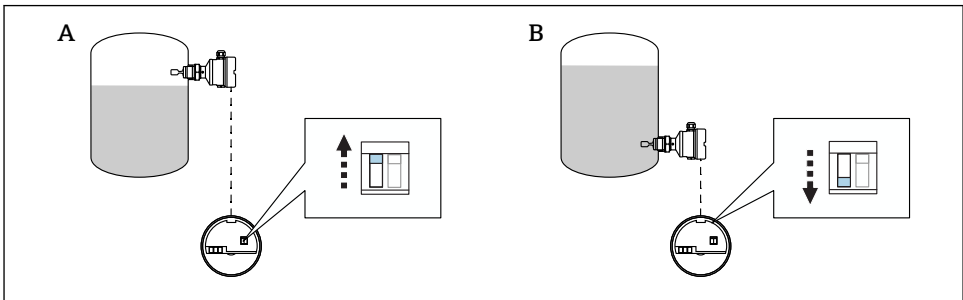

A0039743

13 Switch position on electronic insert

A MAX setting

B MIN setting

 The switch position depends on the electronic insert.

7.2.2 Switching behaviour and signaling for all functions without fault signaling

 See Operating Instructions.

7.2.3 Limit signal H with fault signaling

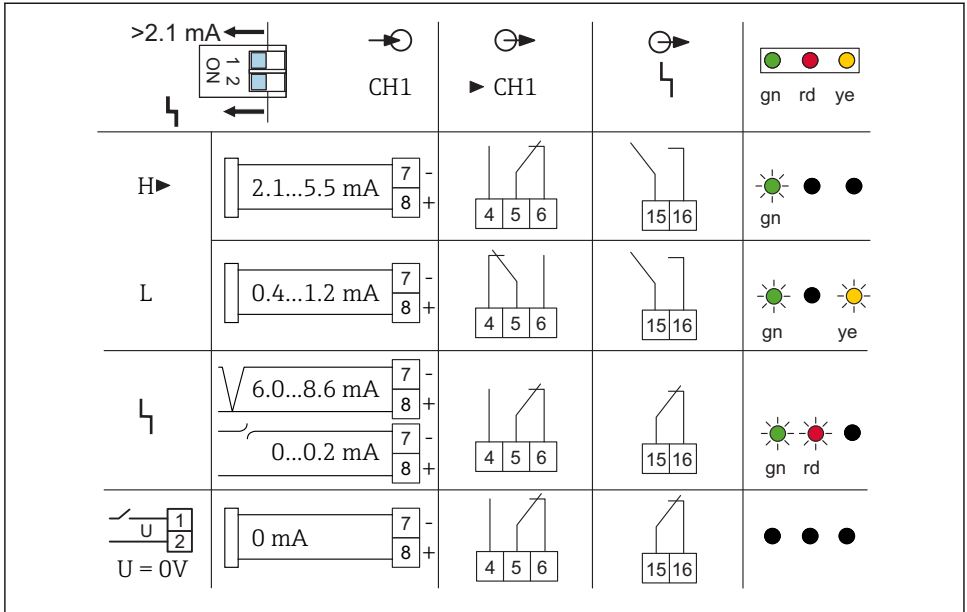

A0039544

14 Limit signal H with fault signaling (FEL56)

7.2.4 Limit signal L with fault signaling

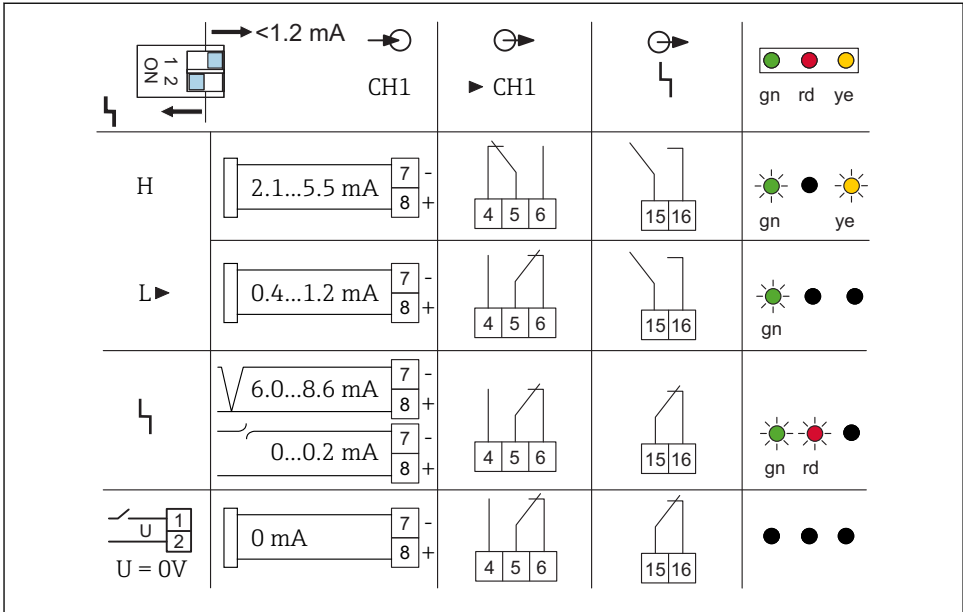

A0039546

15 Limit signal L with fault signaling (FEL58, FEL48, FEL68, FEM58, FEI58)

7.3 Function testing of secondary equipment

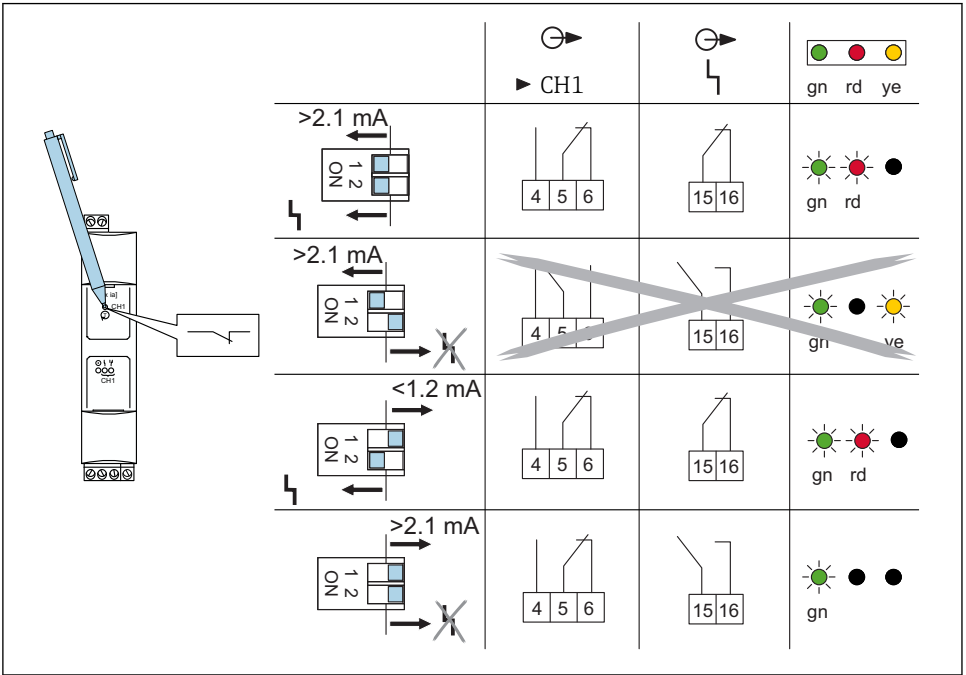

A0039552

Function test

- Press the test button
- The point level relay and alarm relay switch (in accordance with the diagram).



For proof testing in accordance with SIL and WHG, the associated WHG documents or the SIL Functional safety manual must be complied with.



71442316

www.addresses.endress.com
