

Safety Instructions

Cerabar M

PMC51, PMP51, PMP55

4-20 mA HART, PROFIBUS PA, FOUNDATION Fieldbus

Ex ta IIC T75°C Da

Ex tb IIC T75°C Db



Document: XA01953P-A

Safety instructions for electrical apparatus for explosion-hazardous areas →  3

Cerabar M PMC51, PMP51, PMP55

4-20 mA HART, PROFIBUS PA, FOUNDATION Fieldbus

Table of contents

Associated documentation	4
Supplementary documentation	4
Manufacturer's certificates	4
Manufacturer address	4
Extended order code	4
Safety instructions: General	5
Safety instructions: Special conditions	6
Safety instructions: Installation	6
Temperature tables	6
Connection data	6

Associated documentation	<p>This document is an integral part of the following Operating Instructions:</p> <p>HART BA00382P/00</p> <p>PROFIBUS PA BA00383P/00</p> <p>FOUNDATION Fieldbus BA00384P/00</p>										
Supplementary documentation	<p>Explosion-protection brochure: CP00021Z/11</p> <p>The Explosion-protection brochure is available:</p> <ul style="list-style-type: none"> ■ In the download area of the Endress+Hauser website: www.endress.com -> Downloads -> Media Type: Documentation -> Documentation Type: Brochures and catalogs -> Text Search: CP00021Z ■ On the CD for devices with CD-based documentation 										
Manufacturer's certificates	<p>Certificate of Conformity TP TC 012/2011</p> <p>Inspection authority: LLC NANIO CCVE (ООО «НАННО ЦСВЭ»)</p> <p>Certificate number: EAЭC RU C-DE.AA87.B.00320/20</p> <p>Affixing the certificate number certifies conformity with the following standards (depending on the device version):</p> <ul style="list-style-type: none"> ■ GOST 31610.0-2014 (IEC 60079-0:2011) ■ GOST IEC 60079-31-2013 										
Manufacturer address	<p>Endress+Hauser SE+Co. KG Hauptstraße 1 79689 Maulburg, Germany</p> <p>Address of the manufacturing plant: See nameplate.</p>										
Extended order code	<p>The extended order code is indicated on the nameplate, which is affixed to the device in such a way that it is clearly visible. Additional information about the nameplate is provided in the associated Operating Instructions.</p> <p>Structure of the extended order code</p> <table border="0" style="width: 100%; text-align: center;"> <tr> <td style="width: 30%;">PMC51, PMP5x</td> <td style="width: 10%;">–</td> <td style="width: 30%;">*****</td> <td style="width: 10%;">+</td> <td style="width: 20%;">A*B*C*D*E*F*G*..</td> </tr> <tr> <td><i>(Device type)</i></td> <td></td> <td><i>(Basic specifications)</i></td> <td></td> <td><i>(Optional specifications)</i></td> </tr> </table> <p>* = Placeholder At this position, an option (number or letter) selected from the specification is displayed instead of the placeholders.</p> <p><i>Basic specifications</i></p> <p>The features that are absolutely essential for the device (mandatory features) are specified in the basic specifications. The number of positions depends on the number of features available. The selected option of a feature can consist of several positions.</p>	PMC51, PMP5x	–	*****	+	A*B*C*D*E*F*G*..	<i>(Device type)</i>		<i>(Basic specifications)</i>		<i>(Optional specifications)</i>
PMC51, PMP5x	–	*****	+	A*B*C*D*E*F*G*..							
<i>(Device type)</i>		<i>(Basic specifications)</i>		<i>(Optional specifications)</i>							

Optional specifications

The optional specifications describe additional features for the device (optional features). The number of positions depends on the number of features available. The features have a 2-digit structure to aid identification (e.g. JA). The first digit (ID) stands for the feature group and consists of a number or a letter (e.g. J = Test, Certificate). The second digit constitutes the value that stands for the feature within the group (e.g. A = 3.1 material (wetted parts), inspection certificate).

More detailed information about the device is provided in the following tables. These tables describe the individual positions and IDs in the extended order code which are relevant to hazardous locations.

Extended order code: Cerabar M

The following specifications reproduce an extract from the product structure and are used to assign:

- This documentation to the device (using the extended order code on the nameplate).
- The device options cited in the document.

Device type

PMC51, PMP51, PMP55

Basic specifications

Position 1, 2 (Approval)		
Selected option		Description
PMC51	GB	EAC Ex ta IIIC T75°C Da
PMP5x		EAC Ex tb IIIC T75°C Db

Position 3 (Output)		
Selected option		Description
PMC51	2	4-20 mA HART
PMP5x	3	PROFIBUS PA
	4	FOUNDATION Fieldbus

Optional specifications

No options specific to hazardous locations are available.

Safety instructions: General

- Comply with the installation and safety instructions in the Operating Instructions.
- Staff must meet the following conditions for mounting, electrical installation, commissioning and maintenance of the device:
 - Be suitably qualified for their role and the tasks they perform
 - Be trained in explosion protection
 - Be familiar with national regulations
- Install the device according to the manufacturer's instructions and national regulations.
- Only use the device in media to which the wetted materials have sufficient durability.
- Avoid electrostatic charging:
 - Of plastic surfaces (e.g. housing, sensor element, special varnishing, attached additional plates, ..)
 - Of isolated capacities (e.g. isolated metallic plates)

**Safety instructions:
Special conditions**

- In the case of process connections made of polymeric material or with polymeric coatings, avoid electrostatic charging of the plastic surfaces.
- In the event of additional or alternative special varnishing on the housing or other metal parts:
 - Observe the danger of electrostatic charging and discharge.
 - Do not rub surfaces with a dry cloth.

**Safety instructions:
Installation**

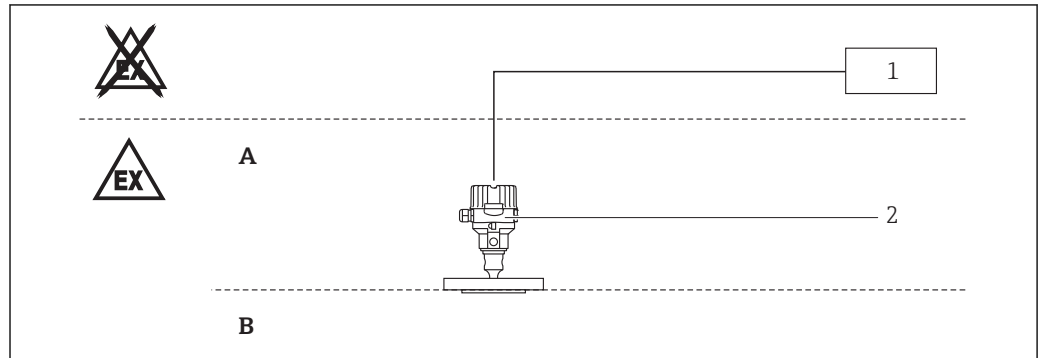

- A Zone 21, Electronic
- B Zone 20, Process
- 1 Power supply U
- 2 PMC51, PMP51, PMP55

- Do not open in a potentially explosive dust atmosphere.
- Seal the cable entry or piping tight (see ingress protection of housing in the "Temperature tables" chapter).
- Connect the device using suitable cable and wire entries of protection type "Equipment dust ignition protection by enclosure (Ex t)" or "Increased safety (Ex e)" (ingress protection of at least IP65). Lay connecting cable and secure.

Temperature tables

Type of protection	Ingress protection of housing	Max. surface temperature under fault conditions	Ambient temperature T_a (ambient): housing
Ex ta III C T75°C Da Ex tb III C T75°C Db	IP66/67	+75 °C ¹⁾	-40 °C ≤ T_a ≤ +70 °C

1) Measured at max. ambient temperatur of +70 °C

Connection data

Basic specification, Position 3 (Output) = 2

Power supply
$U \leq 45 V_{DC}$

Basic specification, Position 3 (Output) = 3, 4

Power supply
$U \leq 32 V_{DC}$



71456077

www.addresses.endress.com
