

Safety Instructions

Micropilot FMR67

4-20 mA HART

II 1 D Ex ta IIIC T₅₀₀ 125°C Da

II 1/2 D Ex ta/tb IIIC T85°C Da/Db



Micropilot FMR67

4-20 mA HART

Table of contents

| | |
|-----------------------------------------------|----|
| Associated documentation | 4 |
| Supplementary documentation | 4 |
| Manufacturer's certificates | 4 |
| Manufacturer address | 4 |
| Other standards | 4 |
| Extended order code | 5 |
| Safety instructions: General | 8 |
| Safety instructions: Special conditions | 9 |
| Safety instructions: Installation | 10 |
| Temperature tables | 11 |
| Connection data | 18 |

| | |
|------------------------------------|-------------------------------------------------------------------------------------------------------------------------------------------------------------------------------------------------------------------------------------------------------------------------------------------------------------------------------------------------------------------------------------------------------------------------------------------------------------------------------------------------------------------|
| Associated documentation | <p>This document is an integral part of the following Operating Instructions: BA01620F/00</p> |
| Supplementary documentation | <p>Explosion-protection brochure: CP00021Z/11 The Explosion-protection brochure is available:</p> <ul style="list-style-type: none">■ In the download area of the Endress+Hauser website: www.endress.com -> Downloads -> Brochures and Catalogs -> Text Search: CP00021Z■ On the CD for devices with CD-based documentation |
| Manufacturer's certificates | <p>UK Declaration of Conformity</p> <p>Declaration Number: EC_00874</p> <p>The UK Declaration of Conformity is available: In the download area of the Endress+Hauser website: www.endress.com -> Downloads -> Declaration -> Type: EU Declaration -> Product Code: ...</p> <p>UKCA type-examination certificate</p> <p>Certificate number: CML 21UKEX2087X</p> <p>List of applied standards: See UK Declaration of Conformity.</p> |
| Manufacturer address | <p>Endress+Hauser SE+Co. KG Hauptstraße 1 79689 Maulburg, Germany Address of the manufacturing plant: See nameplate.</p> |
| Other standards | <p>Among other things, the following standards shall be observed in their current version for proper installation:</p> <ul style="list-style-type: none">■ IEC/EN 60079-14: "Explosive atmospheres - Part 14: Electrical installations design, selection and erection"■ EN 1127-1: "Explosive atmospheres - Explosion prevention and protection - Part 1: Basic concepts and methodology" |

Extended order code

The extended order code is indicated on the nameplate, which is affixed to the device in such a way that it is clearly visible. Additional information about the nameplate is provided in the associated Operating Instructions.

Structure of the extended order code

| | | | | |
|----------------------|---|-------------------------------|---|----------------------------------|
| FMR67 | – | ***** | + | A*B*C*D*E*F*G*.. |
| <i>(Device type)</i> | | <i>(Basic specifications)</i> | | <i>(Optional specifications)</i> |

* = Placeholder

At this position, an option (number or letter) selected from the specification is displayed instead of the placeholders.

Basic specifications

The features that are absolutely essential for the device (mandatory features) are specified in the basic specifications. The number of positions depends on the number of features available. The selected option of a feature can consist of several positions.

Optional specifications

The optional specifications describe additional features for the device (optional features). The number of positions depends on the number of features available. The features have a 2-digit structure to aid identification (e.g. JA). The first digit (ID) stands for the feature group and consists of a number or a letter (e.g. J = Test, Certificate). The second digit constitutes the value that stands for the feature within the group (e.g. A = 3.1 material (wetted parts), inspection certificate).

More detailed information about the device is provided in the following tables. These tables describe the individual positions and IDs in the extended order code which are relevant to hazardous locations.

Extended order code: Micropilot



The following specifications reproduce an extract from the product structure and are used to assign:

- This documentation to the device (using the extended order code on the nameplate).
- The device options cited in the document.

Device type

FMR67

Basic specifications

| Position 1, 2 (Approval) | | |
|--------------------------|------------------|---------------------------------------------------|
| Selected option | Description | |
| FMR67 | UE ¹⁾ | UK Ex II 1 D Ex ta IIIC T ₅₀₀ 125°C Da |
| | UF ²⁾ | UK Ex II 1/2 D Ex ta/tb IIIC T85°C Da/Db |

- 1) The designation changes in connection with Position 4 = L, M, N:
II 1 D Ex ta [ia Da] IIIC T₅₀₀ 125°C Da
- 2) The designation changes in connection with Position 4 = L, M, N:
II 1/2 D Ex ta/tb [ia Da] IIIC T85°C Da/Db

| Position 3 (Power Supply, Output) | | |
|-----------------------------------|-------------|-------------------------------------------|
| Selected option | Description | |
| FMR67 | A | 2-wire, 4-20 mA HART |
| | B | 2-wire, 4-20 mA HART, switch output (PFS) |
| | C | 2-wire, 4-20 mA HART, 4 to 20 mA |

| Position 4 (Display, Operation) | | |
|---------------------------------|-----------------|------------------------------------------------------------|
| Selected option | Description | |
| FMR67 | A | Without, via communication |
| | C | SD02, 4-line, push buttons + data backup function |
| | E | SD03, 4-line, illum., touch control + data backup function |
| | L ¹⁾ | Prepared for display FHX50 + M12 connection |
| | M ¹⁾ | Prepared for display FHX50 + custom connection |
| | N ¹⁾ | Prepared for display FHX50 + NPT1/2" |

- 1) UK Ex approved version of FHX50

| Position 5 (Housing) | | |
|----------------------|-------------|------------------------------------|
| Selected option | Description | |
| FMR67 | B | GT18 dual compartment, 316L |
| | C | GT20 dual compartment, Alu, coated |

| Position 6 (Electrical Connection) | | |
|------------------------------------|-----------------|----------------------------------|
| Selected option | | Description |
| FMR6x | A ¹⁾ | Gland M20, IP66/68 NEMA4X/6P |
| | B | Thread M20, IP66/68 NEMA4X/6P |
| | C | Thread G1/2, IP66/68 NEMA4X/6P |
| | D | Thread NPT1/2, IP66/68 NEMA4X/6P |

1) Only in connection with Position 1, 2 = UF

| Position 7, 8 (Antenna) | | |
|-------------------------|----|-----------------------|
| Selected option | | Description |
| FMR67 | GA | Drip-off, PTFE DN50 |
| | GP | PTFE flush mount DN80 |

 Shown in the temperature tables exemplary as follows:

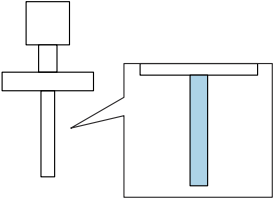

| Position 9, 10 (Seal) | | |
|-----------------------|----|----------------------------------------|
| Selected option | | Description |
| FMR67 | A3 | FKM Viton GLT, -40...80°C/-40...176°F |
| | A5 | FKM Viton GLT, -40...150°C/-40...302°F |
| | A6 | FKM Viton GLT, -40...200°C/-40...392°F |

 Shown in the temperature tables exemplary as follows:

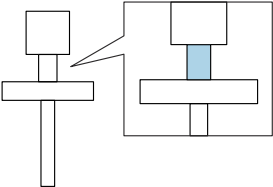

| Position 11-13 (Process Connection) | | |
|-------------------------------------|-----|------------------------------------|
| Selected option | | Description |
| FMR67 | AxJ | Flange (different sizes), 316/316L |
| | CxJ | Flange (different sizes), 316L |
| | GGJ | Thread ISO228 G1-1/2, 316L |
| | KxJ | Flange (different sizes), 316L |
| | RGJ | Thread ANSI MNPT1-1/2, 316L |
| | XxA | Align. device (different sizes) |
| | XxG | Flange (different sizes), PP |
| | XxJ | Flange (different sizes), 316L |

| Position 14 (Air Purge Connection) | | |
|------------------------------------|-----------------|----------------|
| Selected option | | Description |
| FMR67 | A ¹⁾ | W/o |
| | 1 ²⁾ | G1/4 |
| | 2 ²⁾ | NPT1/4 |
| | 3 ¹⁾ | Adapter G1/4 |
| | 4 ¹⁾ | Adapter NPT1/4 |

- 1) Only in connection with Position 7, 8 = GA
 2) Only in connection with Position 7, 8 = GP

Optional specifications

| ID Nx (Accessory Mounted) | | |
|---------------------------|------------------|-------------|
| Selected option | | Description |
| FMR6x | NF ¹⁾ | Bluetooth |

- 1) Only in connection with Position 4 = C, E

Safety instructions: General

- Staff must meet the following conditions for mounting, electrical installation, commissioning and maintenance of the device:
 - Be suitably qualified for their role and the tasks they perform
 - Be trained in explosion protection
 - Be familiar with national regulations
- Install the device according to the manufacturer's instructions and national regulations.
- Do not operate the device outside the specified electrical, thermal and mechanical parameters.

- Only use the device in media to which the wetted materials have sufficient durability.
- Avoid electrostatic charging:
 - Of plastic surfaces (e.g. enclosure, sensor element, special varnishing, attached additional plates, ..)
 - Of isolated capacities (e.g. isolated metallic plates)
- Modifications to the device can affect the explosion protection and must be carried out by staff authorized to perform such work by Endress+Hauser.
- Refer to the temperature tables for the relationship between the permitted ambient temperature for the sensor and/or transmitter, depending on the range of application and the temperature class.

Safety instructions:
Special conditions

Permitted ambient temperature range at the electronics enclosure:
 $-40\text{ °C} \leq T_a \leq +80\text{ °C}$

- Observe the information in the temperature tables.
- In the case of process connections made of polymeric material or with polymeric coatings, avoid electrostatic charging of the plastic surfaces.
- To avoid electrostatic charging: Do not rub surfaces with a dry cloth.
- In the event of additional or alternative special varnishing on the enclosure or other metal parts or for adhesive plates:
 - Observe the danger of electrostatic charging and discharge.
 - Do not install in the vicinity of processes ($\leq 0.5\text{ m}$) generating strong electrostatic charges.
- Avoid electrostatic charging of the sensor (e.g. do not rub dry and install outside the filling flow).

Device type FMR67 and Basic specification, Position 11-13 = XxA

- Changing the position of the alignment device must be impossible:
 - After the alignment of the antenna via the pivot bracket
 - After tightening of the clamping flange
 - After setting the damping ring (torque 10 to 11 Nm)
- Degree of protection IP67 must be fulfilled.

Device type FMR67 and Basic specification, Position 14 = 1, 2

- If equipment with Ga/Gb or Da/Db is required: In the closed state the minimum degree of protection of the installation must be IP67.
- After removing the air purge connection: Lock the opening with a suitable plug.
 - Torque: 6-7 Nm
 - For Da/Db: thread engagement > 5 turns
- Degree of protection IP67 must be fulfilled.

Safety instructions: Installation

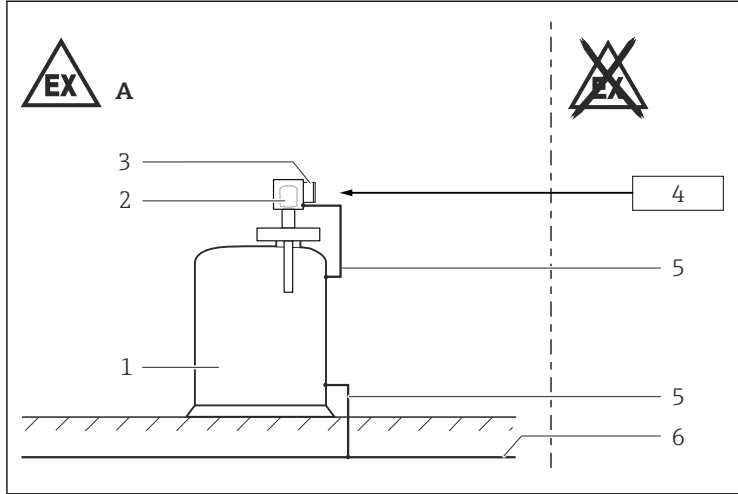

A0025537

- A Zone 20, Zone 21
 1 Tank; Zone 20, Zone 21
 2 Electronics compartment Ex ia; Electronic insert
 3 Connection compartment Ex tb
 4 Power supply
 5 Potential equalization line
 6 Potential equalization

- After aligning (rotating) the enclosure, retighten the fixing screw (see Operating Instructions).
- Install the device to exclude any mechanical damage or friction during the application. Pay particular attention to flow conditions and tank fittings.
- Only use certified cable entries or sealing plugs. The metal sealing plugs supplied meet this requirement.
- Before operation:
 - Screw in the cover all the way.
 - Tighten the securing clamp on the cover.
- After mounting and connecting the antenna, ingress protection of the enclosure must be at least IP65.
- Perform the following to achieve the degree of protection:
 - Screw the cover tight.
 - Mount the cable entry correctly.
- Continuous service temperature of the connecting cable: -40 °C to $\geq +85\text{ °C}$; in accordance with the range of service temperature taking into account additional influences of the process conditions ($T_{a,\min}$), ($T_{a,\max} + 20\text{ K}$).

Basic specification, Position 4 = N

Observe the requirements according to IEC/EN 60079-14 for conduit systems and the wiring- and installation instructions of the suitable Safety Instructions (XA). In addition, observe national regulations and standards for conduit systems.

Intrinsic safety

- The device can be connected to the Endress+Hauser FXA291 service tool: refer to the Operating Instructions.
- The device can be equipped with the Bluetooth® module: refer to the Operating Instructions and specifications in the "Bluetooth® module" chapter.

Bluetooth® module

Optional specification, ID Nx = NF

- With Bluetooth® module installed: Use of external hardware not allowed (e.g. external display, service interface).
- The intrinsically safe input power circuit of the Bluetooth® module is isolated from ground.

Temperature tables

Description notes

 Unless otherwise indicated, the positions always refer to the basic specification.

Zone 20

1st column: Position 5 = A, B, ...

2nd column: Calculation of temperature values and maximum permissible ambient temperature in °C

3rd column: Maximum surface temperature in °C

 T_a : Ambient temperature in °C
 T_{500} : Deposited material with a layer of 500 mm

Example table

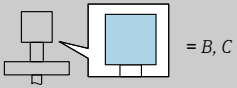
| | | |
|-------------------------------------------------------------------------------------|------------------------------------------------------------|--------------------------|
|  | | |
| | $T = T_a + 10 \text{ K}$ $T_{500} = T_a + 42 \text{ K}$ | $T_a = 75$ $T_a = 43$ |
| | | 125 |

Zone 20, Zone 21

1st column: Position 5 = A, B, ...

2nd column: Process temperature

Column P1 to P5: Position (temperature value) on the axes of the derating

- T_a : Ambient temperature in °C
- T_p : Process temperature in °C

 Column P2+ is only relevant for version B of the derating.

Example table

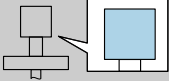
|  = C | | P1 | | P2 | | P2+ | | P3 | | P4 | | P5 | |
|--------------------------------------------------------------------------------------|-----|-------|-------|-------|-------|-------|-------|-------|-------|-------|-------|-------|-------|
| | | T_p | T_a | T_p | T_a | T_p | T_a | T_p | T_a | T_p | T_a | T_p | T_a |
| | 100 | -40 | 75 | 75 | 75 | - | - | 100 | 60 | 100 | -40 | -40 | -40 |
| | 135 | -40 | 75 | 75 | 75 | - | - | 135 | 56 | 135 | -40 | -40 | -40 |
| | 150 | -40 | 75 | 75 | 75 | - | - | 150 | 54 | 150 | -40 | -40 | -40 |

Zone 21

1st column: Position 5 = A, B, ...

2nd column: Calculation of temperature values and maximum permissible ambient temperature in °C

3rd column: Maximum surface temperature in °C

 T_a : Ambient temperature in °C

Example table

|  = B, C | | |
|-------------------------------------------------------------------------------------------|-------------------------|------------|
| | $T = T_a + 10\text{ K}$ | $T_a = 75$ |
| | | 85 |

Example diagrams of possible deratings

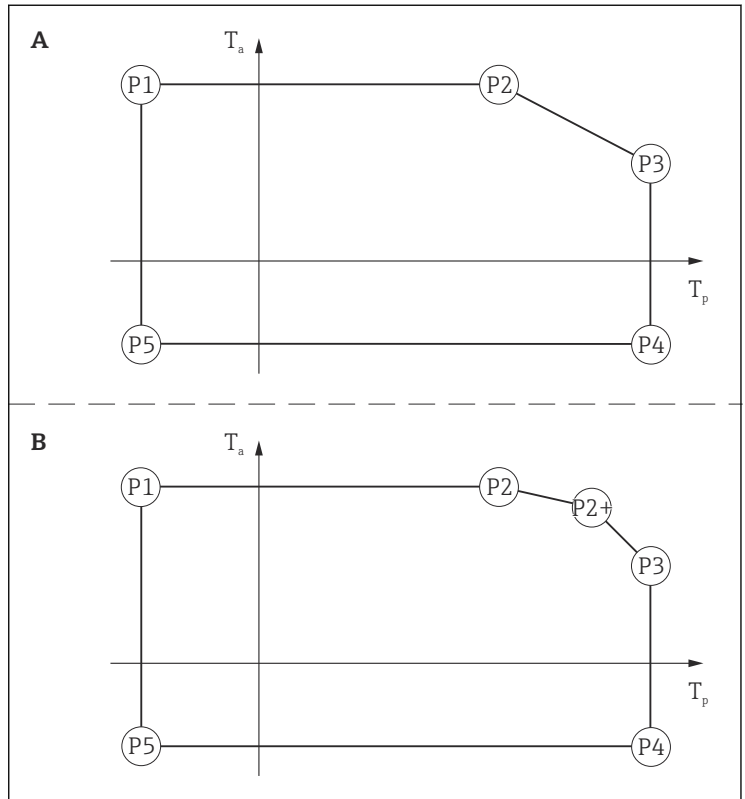

A0031943

Zone 20

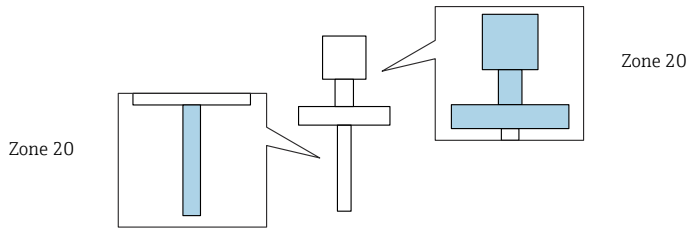

FMR67

| | | | |
|---------------|------------------------------------------------------------|--------------------------|-----|
| <p>= B, C</p> | | | |
| | $T = T_a + 10 \text{ K}$ $T_{500} = T_a + 42 \text{ K}$ | $T_a = 75$ $T_a = 43$ | 125 |

Zone 20, Zone 21

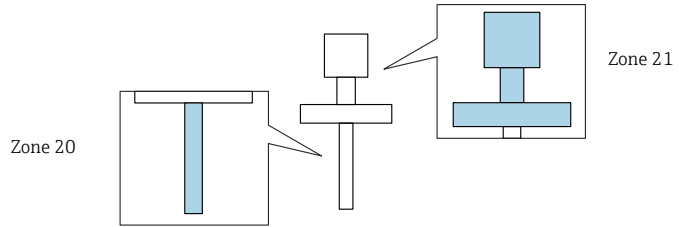

FMR67

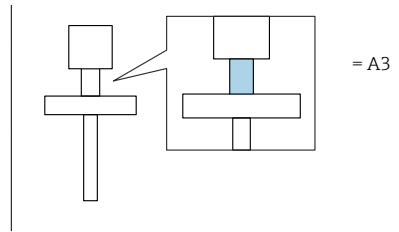
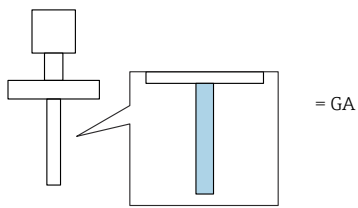

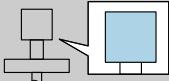
|  = B, C | P1 | | P2 | | P2+ | | P3 | | P4 | | P5 | | | |
|------------------------------------------------------------------------------------------|----------------|----------------|----------------|----------------|----------------|----------------|----------------|----------------|----------------|----------------|----------------|----------------|-----|-----|
| | T _p | T _a | T _p | T _a | T _p | T _a | T _p | T _a | T _p | T _a | T _p | T _a | | |
| | 75 | -40 | 75 | 75 | 75 | 75 | - | - | 75 | 75 | 75 | -40 | -40 | -40 |

FMR67

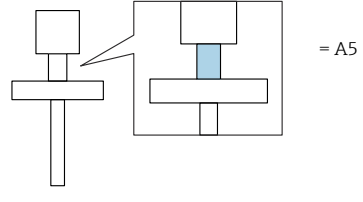
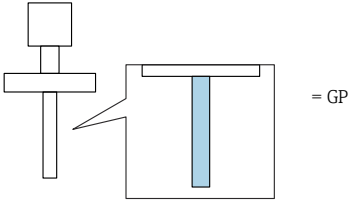

| | P1 | | P2 | | P2+ | | P3 | | P4 | | P5 | |
|-----|----------------|----------------|----------------|----------------|----------------|----------------|----------------|----------------|----------------|----------------|----------------|----------------|
| | T _p | T _a | T _p | T _a | T _p | T _a | T _p | T _a | T _p | T _a | T _p | T _a |
| 100 | -40 | 75 | 75 | 75 | - | - | 100 | 58 | 100 | -40 | -40 | -40 |
| 135 | -40 | 75 | 75 | 75 | - | - | 135 | 52 | 135 | -40 | -40 | -40 |
| 150 | -40 | 75 | 75 | 75 | - | - | 150 | 47 | 150 | -40 | -40 | -40 |

| | P1 | | P2 | | P2+ | | P3 | | P4 | | P5 | |
|-----|----------------|----------------|----------------|----------------|----------------|----------------|----------------|----------------|----------------|----------------|----------------|----------------|
| | T _p | T _a | T _p | T _a | T _p | T _a | T _p | T _a | T _p | T _a | T _p | T _a |
| 100 | -40 | 75 | 75 | 75 | - | - | 100 | 60 | 100 | -40 | -40 | -40 |
| 135 | -40 | 75 | 75 | 75 | - | - | 135 | 56 | 135 | -40 | -40 | -40 |
| 150 | -40 | 75 | 75 | 75 | - | - | 150 | 54 | 150 | -40 | -40 | -40 |

FMR67

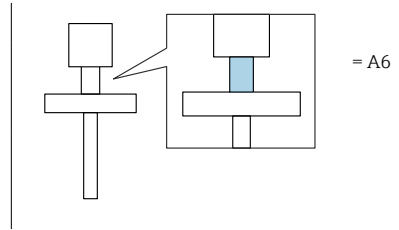
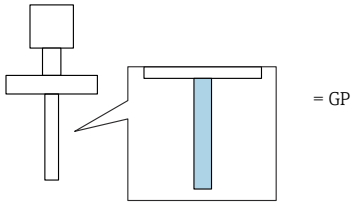

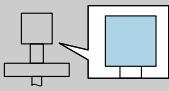
|  = B, C | P1 | | P2 | | P2+ | | P3 | | P4 | | P5 | | |
|---------------------------------------------------------------------------------------------|----------------|----------------|----------------|----------------|----------------|----------------|----------------|----------------|----------------|----------------|----------------|----------------|-----|
| | T _p | T _a | T _p | T _a | T _p | T _a | T _p | T _a | T _p | T _a | T _p | T _a | |
| | 100 | -40 | 75 | 75 | 75 | - | - | 100 | 61 | 100 | -40 | -40 | -40 |
| | 135 | -40 | 75 | 75 | 75 | - | - | 135 | 58 | 135 | -40 | -40 | -40 |
| | 200 | -40 | 75 | 75 | 75 | - | - | 200 | 53 | 200 | -40 | -40 | -40 |

Zone 21

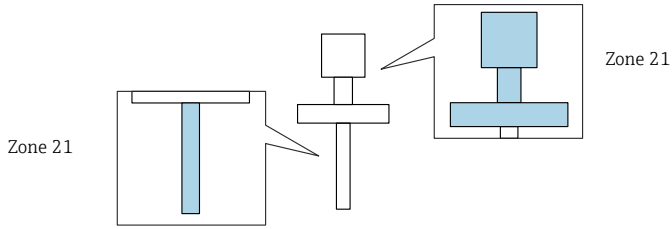

FMR67

| | | |
|--|-------------------------|------------|
| | | |
| | $T = T_a + 10\text{ K}$ | $T_a = 75$ |
| | | 85 |

Connection data Cable entry: Connection compartment

Ex ta

Basic specification, Position 1, 2 = UE

Cable gland: No cable gland available.

Ex tb

Basic specification, Position 1, 2 = UF

Cable gland: *Basic specification, Position 6 = A*

Basic specification, Position 5 = B, C

preferably for Position 5 = B

| Thread | Clamping range | Material | Sealing insert | O-ring |
|---------|----------------|----------|----------------|---------------|
| M20x1,5 | ø 7 to 12 mm | 1.4404 | NBR | EPDM (ø 17x2) |

preferably for Position 5 = C

| Thread | Clamping range | Material | Sealing insert | O-ring |
|---------|----------------------------------------------------------------|-------------------|----------------|---------------|
| M20x1,5 | ø 8 to 10.5 mm ¹⁾ (ø 6.5 to 13 mm) ²⁾ | Ms, nickel-plated | Silicone | EPDM (ø 17x2) |

1) Standard

2) Separate clamping inserts available

- Only suitable for fixed installation. The operator must pay attention to a suitable strain relief of the cable.
- The cable glands are suitable for a low risk of mechanical danger (4 Joule) and must be mounted in a protected position if larger impact energy levels are expected.
- To maintain the ingress protection of the enclosure: Install the enclosure cover, cable glands and blind plugs correctly.

Cable entry: Electronics compartment

Cable gland: *Basic specification, Position 4 = M*

Basic specification, Position 5 = B, C

preferably for Position 5 = B

| Thread | Clamping range | Material | Sealing insert | O-ring |
|---------|----------------|----------|----------------|--------|
| M16x1,5 | ø 5 to 10 mm | 1.4404 | PA/NBR | NBR |

preferably for Position 5 = C

| Thread | Clamping range | Material | Sealing insert | O-ring |
|---------|----------------|-------------------|----------------|--------|
| M16x1,5 | ø 5 to 10 mm | Ms, nickel-plated | PA/NBR | NBR |

- Only suitable for fixed installation. The operator must pay attention to a suitable strain relief of the cable.
- The cable glands are suitable for a low risk of mechanical danger (4 Joule) and must be mounted in a protected position if larger impact energy levels are expected.
- To maintain the ingress protection of the enclosure: Install the enclosure cover, cable glands and blind plugs correctly.

Terminals: Connection compartment

Optional specification, ID Nx = NF

When using the Bluetooth® module: No changes to the connection values.

Ex ta

Basic specification, Position 3 = A

| Terminal 1 (+), 2 (-) |
|-----------------------------------------------------------------------------------------------|
| Power supply ¹⁾ : $U_N = 35 V_{DC}$ $U_m = 250 V$ $I_{Fault} = 54 mA$ |

1) Observe "Power limitation 4 to 20 mA", →  20

Basic specification, Position 3 = B

| Terminal 1 (+), 2 (-) | Terminal 3 (+), 4 (-) |
|---------------------------------------------------------------------------------------------------------------------------------|--------------------------------------------------------------------------------------------------|
| Power supply ¹⁾ : $U_N = 35 \text{ V}_{\text{DC}}$ $U_m = 250 \text{ V}$ $I_{\text{Fault}} = 54 \text{ mA}$ | Switch output (PFS) ²⁾ : $U_N = 35 \text{ V}_{\text{DC}}$ $U_m = 250 \text{ V}$ |

- 1) Observe "Power limitation 4 to 20 mA", → 20
- 2) Observe "Power limitation Switch output (PFS)", → 22

Basic specification, Position 3 = C

| Terminal 1 (+), 2 (-) | Terminal 3 (+), 4 (-) |
|---------------------------------------------------------------------------------------------------------------------------------|--------------------------------------------------------------------------------------------------------------------------------------|
| Power supply ¹⁾ : $U_N = 30 \text{ V}_{\text{DC}}$ $U_m = 250 \text{ V}$ $I_{\text{Fault}} = 54 \text{ mA}$ | Output 4 to 20 mA ¹⁾ : $U_N = 30 \text{ V}_{\text{DC}}$ $U_m = 250 \text{ V}$ $I_{\text{Fault}} = 54 \text{ mA}$ |

- 1) Observe "Power limitation 4 to 20 mA", → 20

Power limitation 4 to 20 mA*Basic specification, Position 3 = A, B, C*

The power consumption of each 4 to 20 mA channel has to be limited to a defined value.

This is achieved by:

- using a power supply with power limitation:
 - $I_{\text{max}} = 54 \text{ mA}$ and 15.74 V
 - *Basic specification, Position 3 = A, B:* $U \leq 35 \text{ V}$
 - *Basic specification, Position 3 = C:* $U \leq 30 \text{ V}$
- monitoring the current and cutting off the supply when 22 mA are exceeded.
- reducing the maximum voltage at the terminals of the device depending on U_N and each channel used (by using a suitable power supply, a limiting resistor or both).

 The limiting resistor is installed outside the device and may be a load/communication resistor or a relay coil. When using it, pay attention to correct load and temperature effects.

Table for minimum external resistors necessary to limit the power consumption in dependence on the supply source:

| | |
|--------------------|---------|
| Power load | 0.85 W |
| Terminal voltage U | 15.74 V |
| I_{Fault} | 0.054 A |

| U_N [V] | R_V min |
|-----------|----------------|
| 35 | 356.7 Ω |
| 34 | 338.1 Ω |
| 33 | 319.6 Ω |
| 32 | 301.1 Ω |
| 31 | 282.6 Ω |
| 30 | 264.1 Ω |
| 29 | 245.5 Ω |
| 28 | 227.0 Ω |
| 27 | 208.5 Ω |
| 26 | 190.0 Ω |
| 25 | 171.5 Ω |
| 24 | 152.9 Ω |
| 23 | 134.4 Ω |
| 22 | 115.9 Ω |
| 21 | 97.4 Ω |
| 20 | 78.9 Ω |
| 19 | 60.4 Ω |
| 18 | 41.8 Ω |
| 17 | 23.3 Ω |
| 16 | 4.8 Ω |
| 15 | 0 Ω |

Power limitation Switch output (PFS)

Basic specification, Position 3 = B

To limit the temperature rise it is necessary to limit the power consumption of the Switch output (PFS).

This is achieved by:

- using a supply voltage by consideration of $R_{i_{\text{Fault}}}$ and terminal voltage $U = 19.5 \text{ V}$.
- using a power supply with power limitation:
 - $I_{\text{max}} = 51.3 \text{ mA}$ and 19.5 V
 - *Basic specification, Position 3 = B: $U \leq 35 \text{ V}$*
- using an external resistor.
- reducing the maximum voltage at the terminals of the device depending on U_N and the channel used (by using a suitable power supply, a limiting resistor or both).



The limiting resistor is installed outside the device and may be a load/communication resistor or a relay coil. When using it, pay attention to correct load and temperature effects.

Table of external resistors depending on power load and supply voltage:

| | |
|------------------------|----------------|
| Power load | 1.0 W |
| Terminal voltage U | 19.5 V |
| I_{Fault} | 0.0513 A |
| $R_{i_{\text{Fault}}}$ | 380.3 Ω |

| U_N [V] | R_N min |
|-----------|--------------|
| 35 | 302 Ω |
| 34 | 283 Ω |
| 33 | 263 Ω |
| 32 | 244 Ω |
| 31 | 224 Ω |
| 30 | 205 Ω |
| 29 | 185 Ω |
| 28 | 166 Ω |
| 27 | 146 Ω |
| 26 | 127 Ω |
| 25 | 107 Ω |

| U_N [V] | R_V min |
|-----------|-------------|
| 24 | 88 Ω |
| 23 | 68 Ω |
| 22 | 49 Ω |
| 21 | 29 Ω |
| 20 | 10 Ω |
| 19 | 0 Ω |

Ex tb

Basic specification, Position 3 = A

| Terminal 1 (+), 2 (-) |
|----------------------------------------------------------------------------------------------------------------|
| Power supply $U_N = 35 V_{DC}$ $U_m = 250 V$ $I_N = 4$ to 20 mA $I_{max} = 22$ mA $P_N = 0.7 W$ |

Basic specification, Position 3 = B

The power consumption of I/O modules with passive PFS output can be limited for certain applications.

- Recommended: Power consumption = 1 W. This is obtained for a supply voltage at the terminals of 27 V_{DC} .
- For higher supply voltages (U_{max}): Insert a serial resistance (R_V) in order to limit the power consumption, see table below.

Table for the PFS serial resistance (R_V):

| | |
|---------------------------|--------------|
| Power consumption | 1.0 W |
| Total power consumption | 1.88 W |
| Internal resistance R_i | 760 Ω |

| U_{\max} [V] | R_V min |
|----------------|--------------|
| 35 | 205 Ω |
| 34 | 177 Ω |
| 33 | 150 Ω |
| 32 | 122 Ω |
| 31 | 95 Ω |
| 30 | 67 Ω |
| 29 | 39 Ω |
| 28 | 12 Ω |
| 27 | 0 Ω |



For values associated with a higher or lower internal power consumption please contact Endress+Hauser.

| Terminal 1 (+), 2 (-) | Terminal 3 (+), 4 (-) |
|------------------------------------------------------------------------------------------------------------------------------------------|----------------------------------------------------------------------------|
| Power supply $U_N = 35 V_{DC}$ $U_m = 250 V$ $I_N = 4 \text{ to } 20 \text{ mA}$ $I_{\max} = 22 \text{ mA}$ $P_N = 0.7 W$ | Switch output (PFS) $U_N = 35 V_{DC}$ $U_m = 250 V$ $P_N = 0.7 W$ |

Basic specification, Position 3 = C

| Terminal 1 (+), 2 (-) | Terminal 3 (+), 4 (-) |
|------------------------------------------------------------------------------------------------------------------------------------------|-----------------------------------------------------------------------------------------------------------------------------------------------|
| Power supply $U_N = 30 V_{DC}$ $U_m = 250 V$ $I_N = 4 \text{ to } 20 \text{ mA}$ $I_{\max} = 22 \text{ mA}$ $P_N = 0.7 W$ | Output 4 to 20 mA $U_N = 30 V_{DC}$ $U_m = 250 V$ $I_N = 4 \text{ to } 20 \text{ mA}$ $I_{\max} = 22 \text{ mA}$ $P_N = 0.7 W$ |

Terminals: Electronics compartment

Ex ia

Service interface (CDI)

Taking the following values into consideration, the device can be connected to the certified Endress+Hauser FXA291 service tool or a similar interface:

| Service interface | | | | | | | | | | | | | |
|----------------------------------------------------------------------------------------------------------------------------------------|------|------|------|------|------|------|------|------|------|------|-------|-------|-------|
| $U_i = 7.3 \text{ V}$ effective inner inductance $L_i = \text{negligible}$ effective inner capacitance $C_i = \text{negligible}$ | | | | | | | | | | | | | |
| $U_o = 7.3 \text{ V}$ $I_o = 60 \text{ mA}$ $P_o = 110 \text{ mW}$ | | | | | | | | | | | | | |
| $L_o \text{ (mH)} =$ | 5.00 | 2.00 | 1.00 | 0.50 | 0.20 | 0.15 | 0.10 | 0.05 | 0.02 | 0.01 | 0.005 | 0.002 | 0.001 |
| $C_o \text{ (}\mu\text{F)}^{1) =}$ | 0.73 | 1.20 | 1.60 | 2.00 | 2.60 | - | 3.20 | 4.00 | 5.50 | 7.30 | 10.00 | 12.70 | 12.70 |
| $C_o \text{ (}\mu\text{F)}^{2) =}$ | - | 0.49 | 0.90 | 1.40 | - | 2.00 | - | - | - | - | - | - | - |

1) Values according to PTB "ispark" program

2) Values according to IEC/EN 60079-25, Annex C



71532711

www.addresses.endress.com
