

Safety Instructions

Liquiphant M FTL51C

ATEX, IECEx: Ex ia IIC Ga/Gb



Liquiphant M FTL51C

Table of contents

About this document	4
Associated documentation	4
Supplementary documentation	4
Manufacturer's certificates	4
Manufacturer address	5
Other standards	5
Extended order code	5
Safety instructions: General	7
Safety instructions: Special conditions	8
Safety instructions: Installation	9
Temperature tables	13
Connection data	16

About this document



This document has been translated into several languages. Legally determined is solely the English source text.

The document translated into EU languages is available:

- In the download area of the Endress+Hauser website:
www.endress.com -> Downloads -> Manuals and Datasheets -> Type: Ex Safety Instruction (XA) -> Text Search: ...
- In the Device Viewer: www.endress.com -> Product tools -> Access device specific information -> Check device features



If not yet available, the document can be ordered.

Associated documentation

This document is an integral part of the following Operating Instructions:

KA00162F/00, KA00165F/00

Supplementary documentation

Explosion-protection brochure: CP00021Z/11

The Explosion-protection brochure is available:

- In the download area of the Endress+Hauser website:
www.endress.com -> Downloads -> Brochures and Catalogs -> Text Search: CP00021Z
- On the CD for devices with CD-based documentation

Manufacturer's certificates

EU Declaration of Conformity

Declaration Number:
EG99021

The EU Declaration of Conformity is available:

In the download area of the Endress+Hauser website:
www.endress.com -> Downloads -> Declaration -> Type: EU Declaration -> Product Code: ...

EU type-examination certificate

Certificate number:
KEMA 99 ATEX 0523 X

List of applied standards: See EU Declaration of Conformity.

IEC Declaration of Conformity

Certificate number:
IECEX DEK 15.0028X

Affixing the certificate number certifies conformity with the following standards (depending on the device version):

- IEC 60079-0 : 2017
- IEC 60079-11 : 2011
- IEC 60079-26 : 2021

Manufacturer address

Endress+Hauser SE+Co. KG
Hauptstraße 1
79689 Maulburg, Germany
Address of the manufacturing plant: See nameplate.

Other standards

Among other things, the following standards shall be observed in their current version for proper installation:

- IEC/EN 60079-14: "Explosive atmospheres - Part 14: Electrical installations design, selection and erection"
- EN 1127-1: "Explosive atmospheres - Explosion prevention and protection - Part 1: Basic concepts and methodology"

Extended order code

The extended order code is indicated on the nameplate, which is affixed to the device in such a way that it is clearly visible. Additional information about the nameplate is provided in the associated Operating Instructions.

Structure of the extended order code

FTL51C	-	*****	+	A*B*C*D*E*F*G*..
<i>(Device type)</i>		<i>(Basic specifications)</i>		<i>(Optional specifications)</i>

* = Placeholder

At this position, an option (number or letter) selected from the specification is displayed instead of the placeholders.

Basic specifications

The features that are absolutely essential for the device (mandatory features) are specified in the basic specifications. The number of

positions depends on the number of features available.
The selected option of a feature can consist of several positions.

Optional specifications

The optional specifications describe additional features for the device (optional features). The number of positions depends on the number of features available. The features have a 2-digit structure to aid identification (e.g. JA). The first digit (ID) stands for the feature group and consists of a number or a letter (e.g. J = Test, Certificate). The second digit constitutes the value that stands for the feature within the group (e.g. A = 3.1 material (wetted parts), inspection certificate).

More detailed information about the device is provided in the following tables. These tables describe the individual positions and IDs in the extended order code which are relevant to hazardous locations.

Extended order code: Liquiphant M



The following specifications reproduce an extract from the product structure and are used to assign:

- This documentation to the device (using the extended order code on the nameplate).
- The device options cited in the document.

Device type

FTL51C

Basic specifications

Position 1 (Approval)		
Selected option		Description
FTL51C	4	ATEX II 1/2 G Ex ia IIC T6...T1 Ga/Gb IECEX Ex ia IIC T6...T1 Ga/Gb

Position 5, 6 (Probe Length, Type)		
Selected option		Description
FTL51C	xK	ECTFE
	xL	PFA (Edlon)
	xM	PFA (RubyRed)

Position 7 (Electronics, Output)		
Selected option		Description
FTL51C	A	FEL50A; PROFIBUS PA
	D	FEL50D; density/concentration, density electronics w/o WHG approval
	5	FEL55; SIL 8/16mA, 11-36VDC
	6	FEL56; SIL NAMUR (L-H signal)
	7	FEL57; SIL 2-wire PFM
	8	FEL58; SIL NAMUR+test button (H-L signal)

Position 8, 9 (Housing, Cable Entry)		
Selected option		Description
FTL51C	x1	F27, 316L
	x5	F13, Alu
	x6	F15, 316L hygiene
	x7	T13, Alu, coated.; separate conn. compartment

Position 11 (Additional Option 2)		
Selected option		Description
FTL51C	A	Not selected
	B	Temp. separator
	C	2nd line of defence (press.tight feed through)

Optional specifications

No options specific to hazardous locations are available.

Safety instructions: General

- The device is intended to be used in explosive atmospheres as defined in the scope of IEC 60079-0 or equivalent national standards. If no potentially explosive atmospheres are present or if additional protective measures have been taken: The device may be operated according to the manufacturer's specifications.
- Staff must meet the following conditions for mounting, electrical installation, commissioning and maintenance of the device:
 - Be suitably qualified for their role and the tasks they perform
 - Be trained in explosion protection
 - Be familiar with national regulations
- Install the device according to the manufacturer's instructions and national regulations.

- Do not operate the device outside the specified electrical, thermal and mechanical parameters.
- Only use the device in media to which the wetted materials have sufficient durability.
- Avoid electrostatic charging:
 - Of plastic surfaces (e.g. enclosure, sensor element, special varnishing, attached additional plates, ..)
 - Of isolated capacities (e.g. isolated metallic plates)
- Refer to the temperature tables for the relationship between the permitted ambient temperature for the sensor and/or transmitter, depending on the range of application and the temperature class.
- Modifications to the device can affect the explosion protection and must be carried out by staff authorized to perform such work by Endress+Hauser.
- The probe is made of stainless steel or high corrosion-resistant alloy of thickness ≥ 1 mm.

**Safety
instructions:
Special conditions**

- Limitations of the maximum ambient temperature at the electronics enclosure may be required dependent on device configuration, process temperatures and temperature classification.
- Details of limitations: →  13, "Temperature tables".
- To avoid electrostatic charging: Do not rub surfaces with a dry cloth.
- In the event of additional or alternative special varnishing on the enclosure or other metal parts or for adhesive plates:
 - Observe the danger of electrostatic charging and discharge.
 - Do not install in the vicinity of processes (≤ 0.5 m) generating strong electrostatic charges.

Basic specification, Position 8, 9 = x5, x7

Avoid sparks caused by impact and friction.

Device group IIC

- Sensors coated with non-conductive material can be used if avoiding electrostatic charging (e.g. through friction, cleaning, maintenance, strong medium flow).
- Marked with warning sign: "Avoid electrostatic charging".

Safety instructions: Installation

Basic specification, Position 7 = D, 5, 6, 7, 8

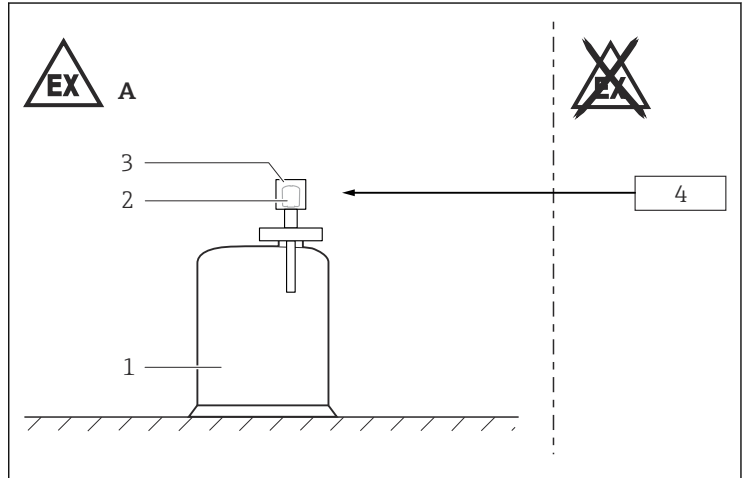

A0034474

1

- A Zone 1
- 1 Tank; Zone 0
- 2 Electronic insert
- 3 Enclosure
- 4 Basic specification, Position 7 = 5, 6, 7, 8:
Associated intrinsically safe power supply units
Basic specification, Position 7 = D:
Only associated intrinsically safe power supply unit FML621 from
Endress+Hauser

Basic specification, Position 7 = A

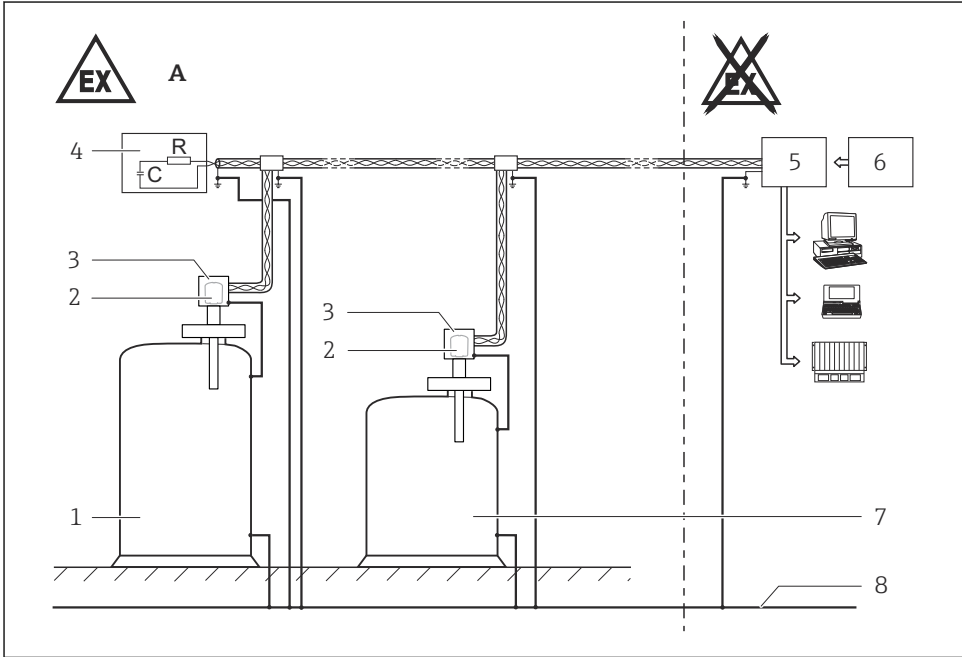

A0034491



- 2
- A Zone 1
 1 Tank; Zone 0
 2 Electronic insert
 3 Enclosure
 4 Permitted terminating resistor Ex ia IIC
 5 Certified associated apparatus
 6 Power supply
 7 Tank; Zone 1
 8 Potential equalization

- Connect the device using suitable cable and wire entries of protection type "Intrinsic safety (Ex i)".
- Continuous service temperature of the connecting cable: $\geq T_a + 5 \text{ K}$.
- Perform the following to achieve the degree of protection IP66/67:
 - Screw the cover tight.
 - Mount the cable entry correctly.
- Seal unused entry glands with approved sealing plugs that correspond to the type of protection.
- Observe the pertinent guidelines when interconnecting intrinsically safe circuits.

- Connection of intrinsically safe PROFIBUS devices: 10 devices.
- Observe the maximum process conditions according to the manufacturer's Operating Instructions.
- At high medium temperatures, note flange pressure load capacity as a factor of temperature.
- Install the device to exclude any mechanical damage or friction during the application. Pay particular attention to flow conditions and tank fittings.
- Support extension tube of the device if a dynamic load is expected.

Intrinsic safety

- The device is only suitable for connection to certified, intrinsically safe equipment with explosion protection Ex ia.
- The intrinsically safe input power circuit of the device is isolated from ground. The dielectric strength is at least 500 V_{rms}.

Potential equalization

- Integrate the device into the local potential equalization.
- Grounding the screen, see the following figure.

Basic specification, Position 7 = A

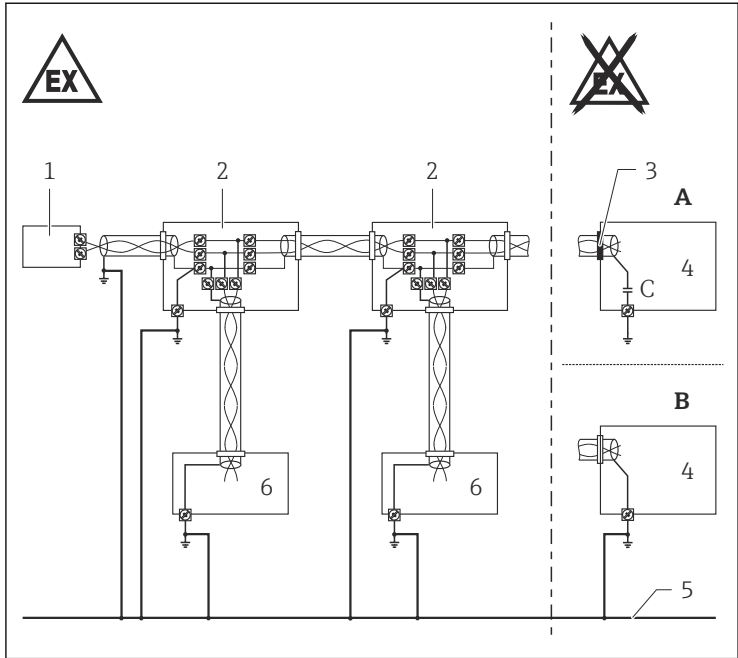

A0022352

☐ 3

- A Version 1: Use small capacitors (e.g. 1 nF, 1 500 V dielectric strength, ceramic). Total capacitance connected to the screen may not exceed 10 nF.
- B Version 2
- 1 Terminating resistor
- 2 Distributor/T box
- 3 Screen insulated
- 4 Supply unit/Segment coupler
- 5 Potential equalization (secured in high degree)
- 6 Field device

Temperature tables

Description notes

 Unless otherwise indicated, the positions always refer to the basic specification.

1st column: Position 11 = A, B, ...

2nd column: Temperature classes T6 (85 °C) to T1 (450 °C)

Column P1 to P5: Position (temperature value) on the axes of the derating

- T_a : Ambient temperature in °C
- T_p : Process temperature in °C

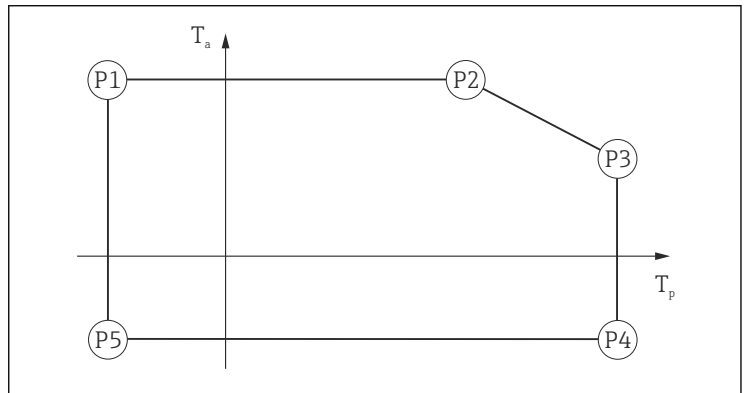

A0033052

Zone 0, Zone 1

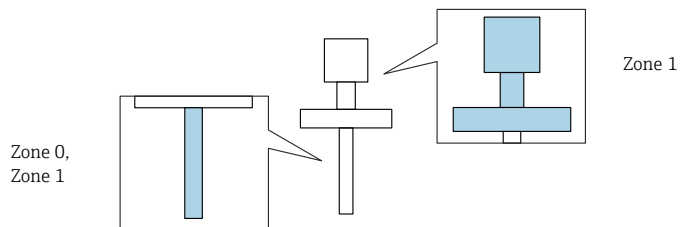

Position 7 = A, D, 5, 7

		P1		P2		P3		P4		P5	
		T _p	T _a	T _p	T _a	T _p	T _a	T _p	T _a	T _p	T _a
A											
	T6	-50	55	55	55	75	45	75	-50 -40 ¹⁾	-50	-50 -40 ¹⁾
	T5...T1	-50	55	55	55	90	40	90	-50 -40 ¹⁾	-50	-50 -40 ¹⁾
B, C											
	T6	-50	55	65	55	75	50	75	-50 -40 ¹⁾	-50	-50 -40 ¹⁾
	T5	-50	55	65	55	90	50	90	-50 -40 ¹⁾	-50	-50 -40 ¹⁾
	T4	-50	55	65	55	125 120 ²⁾	50	125 120 ²⁾	-50 -40 ¹⁾	-50	-50 -40 ¹⁾
	T3...T1	-50	55	65	55	150 120 ²⁾	45	150 120 ²⁾	-50 -40 ¹⁾	-50	-50 -40 ¹⁾

1) Only in connection with Position 8, 9 = x6

2) Only in connection with Position 5, 6 = xK

Position 7 = 6, 8

		P1		P2		P3		P4		P5	
		T _p	T _a	T _p	T _a	T _p	T _a	T _p	T _a	T _p	T _a
A											
	T6	-50	55	67	55	75	55	75	-50 -40 ¹⁾	-50	-50 -40 ¹⁾
	T5	-50	65	70	65	90	55	90	-50 -40 ¹⁾	-50	-50 -40 ¹⁾
	T4...T1	-50	65	70	65	130	40	130	-50 -40 ¹⁾	-50	-50 -40 ¹⁾
B, C											
	T6	-50	55	70	55	75	55	75	-50 -40 ¹⁾	-50	-50 -40 ¹⁾
	T5	-50	65	95	65	90	65	90	-50 -40 ¹⁾	-50	-50 -40 ¹⁾
	T4	-50	65	95	65	125 120 ²⁾	60	125 120 ²⁾	-50 -40 ¹⁾	-50	-50 -40 ¹⁾
	T3...T1	-50	65	95	65	150 120 ²⁾	60	150 120 ²⁾	-50 -40 ¹⁾	-50	-50 -40 ¹⁾

1) Only in connection with Position 8, 9 = x6

2) Only in connection with Position 5, 6 = xK

Connection data

Basic specification, Position 7 = D, 5, 6, 7, 8

Associated intrinsically safe power supply unit with max. electrical specifications below the characteristic values of the electronic inserts

<i>Basic specification, Position 7</i>	Power supply
5	$U_i = 36 \text{ V}$ $I_i = 100 \text{ mA}$ $P_i = 1 \text{ W}$ $L_i = 0$ $C_i = 0$
6	$U_i = 16 \text{ V}$ $I_i = 52 \text{ mA}$ $P_i = 170 \text{ mW}$ $L_i = 0$ $C_i = 30 \text{ nF}$
7	$U_i = 16.7 \text{ V}$ $I_i = 150 \text{ mA}$ $P_i = 1 \text{ W}$ $L_i = 0$ $C_i = 0$
8	$U_i = 16 \text{ V}$ $I_i = 52 \text{ mA}$ $P_i = 170 \text{ mW}$ $L_i = 0$ $C_i = 30 \text{ nF}$

Only associated intrinsically safe power supply unit FML621 from Endress+Hauser

<i>Basic specification, Position 7</i>	Power supply
D	$U_i = 27.6 \text{ V}$ $I_i = 93 \text{ mA}$ $P_i = 640 \text{ mW}$ $L_i = 0.133 \text{ mH}$ $C_i = 2 \text{ nF}$

Basic specification, Position 7 = A

Certified intrinsically safe fieldbus (PROFIBUS PA), in accordance with the FISCO Modell, with the following maximum values

<i>Basic specification, Position 7</i>	Power supply
A	$U_i = 17.5 \text{ V}$ $I_i = 500 \text{ mA}$ $P_i = 5.5 \text{ W}$ $L_i \leq 10 \text{ } \mu\text{H}$ $C_i = 2.7 \text{ nF}$

Certified intrinsically safe circuit with the following maximum values

<i>Basic specification, Position 7</i>	Power supply
A	$U_i = 24 \text{ V}$ $I_i = 250 \text{ mA}$ $P_i = 1.2 \text{ W}$ $L_i \leq 10 \text{ } \mu\text{H}$ $C_i = 2.7 \text{ nF}$



71540481

www.addresses.endress.com
