

Safety Instructions

Micropilot S FMR532, FMR540

4-20 mA HART

II 1/2 G Ex ia IIC T6...T1 Ga/Gb



Micropilot S FMR532, FMR540

4-20 mA HART

Table of contents

Associated documentation	4
Supplementary documentation	4
Manufacturer's certificates	4
Manufacturer address	4
Other standards	4
Extended order code	5
Safety instructions: General	6
Safety instructions: Special conditions	6
Safety instructions: Installation	7
Safety instructions: Zone 0	10
Temperature tables	10
Connection data	12

Associated documentation	<p>This document is an integral part of the following Operating Instructions:</p> <ul style="list-style-type: none">■ BA00208F/00 (FMR532)■ BA00326F/00 (FMR540)
Supplementary documentation	<p>Explosion-protection brochure: CP00021Z/11</p> <p>The Explosion-protection brochure is available:</p> <ul style="list-style-type: none">■ In the download area of the Endress+Hauser website: www.endress.com -> Downloads -> Brochures and Catalogs -> Text Search: CP00021Z■ On the CD for devices with CD-based documentation
Manufacturer's certificates	<p>UK Declaration of Conformity</p> <p>Declaration Number: UK_00086</p> <p>The UK Declaration of Conformity is available: In the download area of the Endress+Hauser website: www.endress.com -> Downloads -> Declaration -> Type: EU Declaration -> Product Code: ...</p> <p>UKCA type-examination certificate</p> <p>Certificate number: CML 21UKEX2835X</p> <p>List of applied standards: See UK Declaration of Conformity.</p>
Manufacturer address	<p>Endress+Hauser SE+Co. KG Hauptstraße 1 79689 Maulburg, Germany</p> <p>Address of the manufacturing plant: See nameplate.</p>
Other standards	<p>Among other things, the following standards shall be observed in their current version for proper installation:</p> <ul style="list-style-type: none">■ IEC/EN 60079-14: "Explosive atmospheres - Part 14: Electrical installations design, selection and erection"■ EN 1127-1: "Explosive atmospheres - Explosion prevention and protection - Part 1: Basic concepts and methodology"

Extended order code

The extended order code is indicated on the nameplate, which is affixed to the device in such a way that it is clearly visible. Additional information about the nameplate is provided in the associated Operating Instructions.

Structure of the extended order code

FMR532, FMR540	-	*****	+	A*B*C*D*E*F*G*..
<i>(Device type)</i>		<i>(Basic specifications)</i>		<i>(Optional specifications)</i>

* = Placeholder

At this position, an option (number or letter) selected from the specification is displayed instead of the placeholders.

Basic specifications

The features that are absolutely essential for the device (mandatory features) are specified in the basic specifications. The number of positions depends on the number of features available.

The selected option of a feature can consist of several positions.

Optional specifications

The optional specifications describe additional features for the device (optional features). The number of positions depends on the number of features available. The features have a 2-digit structure to aid identification (e.g. JA). The first digit (ID) stands for the feature group and consists of a number or a letter (e.g. J = Test, Certificate). The second digit constitutes the value that stands for the feature within the group (e.g. A = 3.1 material (wetted parts), inspection certificate).

More detailed information about the device is provided in the following tables. These tables describe the individual positions and IDs in the extended order code which are relevant to hazardous locations.

Extended order code: Micropilot S



The following specifications reproduce an extract from the product structure and are used to assign:

- This documentation to the device (using the extended order code on the nameplate).
- The device options cited in the document.

Device type

FMR532, FMR540

Basic specifications

Position 1 (Approval)		
Selected option		Description
FMR532	F	UK Ex II 1/2 G Ex ia IIC T6...T1 Ga/Gb
FMR540	H	UK Ex II 1/2 G Ex ia IIC T6...T1 Ga/Gb, WHG

Position 2 (Antenna, Seal)		
Selected option		Description
FMR540	E, 5	Horn (different sizes)
	G, H, 6	Parabolic (different sizes)

Optional specifications

No options specific to hazardous locations are available.

Safety instructions:
General

- Staff must meet the following conditions for mounting, electrical installation, commissioning and maintenance of the device:
 - Be suitably qualified for their role and the tasks they perform
 - Be trained in explosion protection
 - Be familiar with national regulations
- Install the device according to the manufacturer's instructions and national regulations.
- Only use the device in media to which the wetted materials have sufficient durability.
- Avoid electrostatic charging:
 - Of plastic surfaces (e.g. enclosure, sensor element, special varnishing, attached additional plates, ..)
 - Of isolated capacities (e.g. isolated metallic plates)
- Refer to the temperature tables for the relationship between the permitted ambient temperature for the electronics enclosure, depending on the range of application and the temperature class.

Safety instructions:
Special conditions

Permitted ambient temperature range at the electronics enclosure:
 $-40\text{ °C} \leq T_a \leq +80\text{ °C}$

- Observe the information in the temperature tables.
- To avoid electrostatic charging: Do not rub surfaces with a dry cloth.
- In the event of additional or alternative special varnishing on the enclosure or other metal parts or for adhesive plates:
 - Observe the danger of electrostatic charging and discharge.
 - Do not install in the vicinity of processes (≤ 0.5 m) generating strong electrostatic charges.
- Avoid electrostatic charging of the antenna (e.g. friction, cleaning, maintenance, strong medium flow).

Safety instructions: Installation

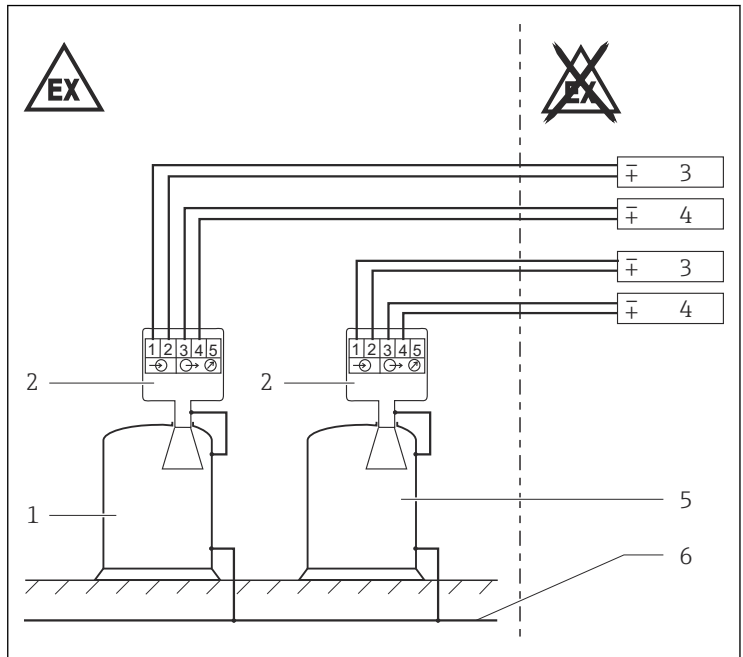

A0036443

 1

- 1 Tank; Hazardous area Zone 0
- 2 Enclosure
- 3 Certified associated apparatus (supply circuit)
- 4 Certified associated apparatus (signal circuit)
- 5 Tank; Hazardous area Zone 1
- 6 Local potential equalization

- After aligning (rotating) the enclosure, retighten the fixing screw.
- Continuous service temperature of the connecting cable: $\geq T_a + 5 \text{ K}$.
- The intrinsically safe input and output power circuits of the device are isolated from ground.
The dielectric strength to earth is limited by 600 V electrode arresters.
- The device is equipped with an internal overvoltage protector (600 V electrode arresters). Connect the metallic enclosure to the tank wall directly with an electrically conductive lead to ensure reliable potential matching.
- Option:
 - Remote display, e.g. FHX40 (Observe Safety Instructions)
 - Overvoltage protector, e.g. HAW56x
- Option (only for service purposes):
Service interface: Commubox with associated ToF cable (Observe Safety Instructions)

Alignment device with center nut

After the alignment of the antenna: Tighten the center nut with a torque between 65 Nm and 85 Nm.

Air purge connection

- In the closed state the minimum degree of protection of the installation must be IP67.
- Purging pressure > internal pressure of the tank.
- In the not purging state a respective stop cock or valve must be closed. With open stop cock or valve and without purging fluid explosible atmospheres may be released or flames may enter from the outside.

Intrinsic safety

- When the device is connected to an intrinsically safe circuit Ex ib, the type of protection changes to Ex ib. Do not operate intrinsically safe circuits Ex ib in Zone 0.
- When the device is connected to an intrinsically safe circuit Ex ic, the type of protection changes to Ex ic. Do not operate intrinsically safe circuits Ex ic in Zone 0 or Zone 1.
- Observe the pertinent guidelines when interconnecting intrinsically safe circuits.

Overvoltage protection

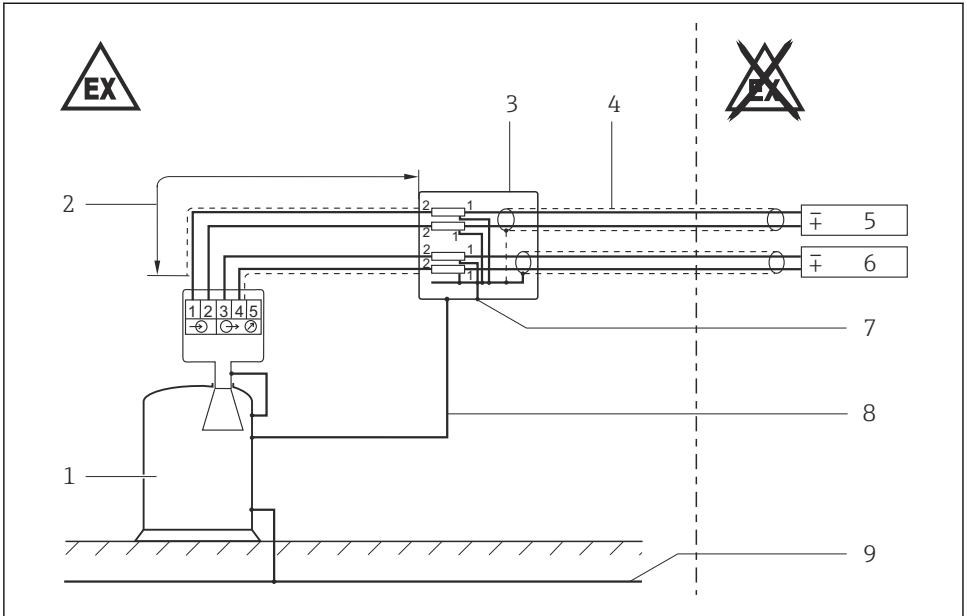

A0036444



- 1 Tank; Hazardous area Zone 0
- 2 <1000 mm, e.g. armoured hose
- 3 Separate enclosure with overvoltage protector, e.g. HAW562Z; Metal enclosure
- 4 Cable with screening or metal sheath
- 5 Certified associated apparatus (supply circuit)
- 6 Certified associated apparatus (signal circuit)
- 7 Potential equalization connection
- 8 Potential equalization line
- 9 Potential equalization



If there is a risk of dangerous potential differences within Zone 0 (e.g. through the occurrence of atmospheric electricity), implement suitable measures for intrinsically safe circuits in Zone 0.

Overvoltage protector HAW56xZ

- Connect the external overvoltage protector and the device to the local potential equalization.
- Establish potential matching both inside and outside of the explosion-hazardous area.
- The cable connecting the overvoltage protector and the measuring device shall be no longer than 1 m.
- Route cable protected (e.g. in an armoured hose).



For notes on screening and installation with associated apparatus (Tank Side Monitor NRF590) see associated Operating Instructions.

Safety instructions: Zone 0

- In the event of potentially explosive vapor/air mixtures, only operate the device under atmospheric conditions.
 - Temperature: -20 to +60 °C
 - Pressure: 80 to 110 kPa (0.8 to 1.1 bar)
 - Air with normal oxygen content, usually 21 % (V/V)
- If no potentially explosive mixtures are present, or if additional protective measures have been taken, the device may also be operated under non-atmospheric conditions in accordance with the manufacturer's specifications.
- Associated devices with galvanic isolation between the intrinsically safe and non-intrinsically safe circuits are preferred.

Temperature tables

Zone 1 - Application

Device type FMR532

Temperature class	Max. permitted temperature at the antenna (Zone 1)	Max. permitted temperature at the electronics enclosure (Zone 1) dependent on the medium temperature
T6	+80 °C +60 °C	+50 °C +55 °C
T5	+95 °C +70 °C	+65 °C +70 °C
T4	+130 °C +80 °C	+70 °C +80 °C
T3	+150 °C	+70 °C

Device type FMR540

Temperature class	Max. permitted temperature at the antenna (Zone 1)	Max. permitted temperature at the electronics enclosure (Zone 1) dependent on the medium temperature
T6	+80 °C +60 °C	+55 °C +60 °C
T5	+95 °C +75 °C	+70 °C +75 °C
T4	+130 °C +80 °C	+75 °C +80 °C
T3	+195 °C +140 °C	+70 °C +75 °C
T2, T1 ¹⁾	+200 °C	+70 °C

1) Functional: Maximum permissible process temperature

Zone 0 - Application

Temperature class	Max. permitted temperature at the antenna (Zone 0)	Max. permitted temperature at the electronics enclosure (Zone 1) dependent on the medium temperature	
		<i>Device type</i>	
		<i>FMR532</i>	<i>FMR540</i>
T6	+60 °C	+55 °C	+60 °C
T5	+60 °C	+65 °C	+75 °C
T4	+60 °C	+80 °C	+80 °C

Connection data Power supply and signal circuit with protection type: intrinsic safety
 Ex ia IIC, Ex ia IIB.
 Certified intrinsically safe circuit with the following maximum values

Power supply	
Power circuit	$U_i = 30 \text{ V}$ $I_i = 300 \text{ mA}$ $P_i = 1 \text{ W}$ $L_i = 13.0 \text{ }\mu\text{H}$ $C_i = 18.5 \text{ nF}$
Signal circuit	$U_i = 30 \text{ V}$ $I_i = 300 \text{ mA}$ $P_i = 1 \text{ W}$ effective inner inductance $L_i = 0$ effective inner capacitance $C_i = 20.7 \text{ nF}$

Zone 1 - Application

Remote display, e.g. FHX40:
 Power supply and signal circuit with protection type: intrinsic safety
 Ex ia IIC, Ex ia IIB.

Power supply	
Device type	
FMR532	FMR540
$U_o = 5.4 \text{ V}$ $I_o = 44 \text{ mA}$ $P_o = 59.4 \text{ mW}$ effective inner inductance $L_i = \text{negligible}$ effective inner capacitance $C_i = \text{negligible}$ Characteristic curve: linear	$U_o = 4.2 \text{ V}$ $I_o = 34 \text{ mA}$ $P_o = 36 \text{ mW}$ effective inner inductance $L_i = \text{negligible}$ effective inner capacitance $C_i = \text{negligible}$ Characteristic curve: linear

Only for service purposes:

Connecting the Commubox service interface with the associated ToF cable

Commubox output + ToF cable						
$U_o = 3.74 \text{ V}$ $I_o = 9.9 \text{ mA}$ $P_o = 9.2 \text{ mW}$ effective inner inductance $L_i = \text{negligible}$ effective inner capacitance $C_i = \text{negligible}$ Characteristic curve: linear						
For material group IIC: <ul style="list-style-type: none"> ▪ permitted outer inductance $L_o \leq 340 \text{ mH}$ ▪ permitted outer capacitance $C_o \leq 100 \mu\text{F}$ 						
When interconnected to a Micropilot S, the following results apply:						
	$L_o =$	0.15 mH	0.5 mH	1 mH	2 mH	5 mH
<i>Device type FMR532</i>						
For material group IIC	$C_o =$	$\leq 5.0 \mu\text{F}$	$\leq 3.5 \mu\text{F}$	$\leq 3.0 \mu\text{F}$	$\leq 2.6 \mu\text{F}$	$\leq 2.0 \mu\text{F}$
<i>Device type FMR540</i>						
For material group IIC	$C_o =$	$\leq 8.0 \mu\text{F}$	$\leq 7.0 \mu\text{F}$	$\leq 5.5 \mu\text{F}$	$\leq 5.0 \mu\text{F}$	$\leq 4.0 \mu\text{F}$
For material group IIB	$C_o =$	10 μF				



71541474

www.addresses.endress.com
