

# Technical Information

## Tankvision Multi Scan NXA83B

### Tank Gauging



Inventory Management System with completely integrated software

#### Application

Tankvision is a dedicated tank inventory system. It is ideally suited for tank farms with various protocols used for communicating with the installed field devices and/or redundancy needs.

Tankvision Multi Scan performs the following tasks:

- scanning of parameters from tank gauges
- provides data to Tankvision Professional NXA85 and Tankvision LMS NXA86B
- provides data to host systems (such as PLC or DCS) via Modbus and/or OPC

#### Your benefits

- Approved for custody transfer applications according to PTB
- Global system engineering and service support
- A robust industrial operating system with embedded software ensures high stability and availability.
- Legacy protocol management; allowing gradual upgrades
- No hard disc or fans - no wear out
- Predefined operator screens via the optional touch display.
- Connects to Tankvision Professional for additional functionality

## Table of contents

<b>Applications</b> .....	<b>3</b>	<b>Registered trademarks</b> .....	<b>11</b>
Inventory control .....	3	Modbus™ .....	11
Remote configuration of measuring equipment .....	3	Microsoft, Windows, Silverlight .....	11
Application areas .....	3	HART® .....	11
		Varec® .....	11
		Others .....	11
<b>Function and system design</b> .....	<b>3</b>		
System design .....	3		
System configuration .....	3		
Features .....	3		
Features with limited functions .....	3		
Security .....	3		
<b>Typical system architecture</b> .....	<b>4</b>		
.....	4		
Tankvision Multi Scan in Switch By System redundancy mode .....	5		
<b>Inputs and Outputs</b> .....	<b>5</b>		
Power supply .....	5		
Interfaces .....	5		
Supported Input protocols (from the field) .....	6		
Device support .....	6		
Supported output/communication (to host system) .....	6		
<b>Environment</b> .....	<b>6</b>		
Mounting location .....	6		
Ambient temperature .....	7		
Storage temperature .....	7		
Relative humidity .....	7		
Electromagnetic compatibility (EMC) .....	7		
<b>Mechanical construction</b> .....	<b>7</b>		
Dimensions .....	7		
Backplane assembly variant 4 channels .....	7		
Backplane assembly variant 12 channels .....	7		
Backplane assembly variant 20 channels .....	8		
<b>Embedded human interface with limited functions</b> .....	<b>8</b>		
LCD display (optional) .....	8		
Remote desktop .....	9		
<b>Installation considerations</b> .....	<b>9</b>		
System requirements of user PC .....	9		
Network requirements .....	9		
Shielding and Grounding .....	9		
<b>Certificates and approvals</b> .....	<b>10</b>		
CE mark .....	10		
<b>Ordering information</b> .....	<b>10</b>		
.....	10		
<b>Documentation</b> .....	<b>10</b>		
Operating Instructions .....	10		

## Applications

<b>Inventory control</b>	By using Tankvision Multi Scan to scan the parameters of tank gauges together with Tankvision Professional to monitor the tank level and stored volume of valuable liquids remotely, owners or operators of tank farms or terminals for petroleum products and chemicals (liquids) can visualize the volume of the stored medium in real time. The data can be used to plan the inventory and distribution. The data can also be used to manage tank farm operations like pumping or transferring products. Tankvision has its unique concept using network technology. Tankvision Multi Scan is a flexible and cost effective solution due to its scalable architecture. The application coverage goes from small depots with only a few tanks up to refineries.
<b>Remote configuration of measuring equipment</b>	Some on-site operations can be avoided using remote configuration of measuring equipment during commissioning or maintenance (the availability of this feature may depend on the system configuration).
<b>Application areas</b>	<ul style="list-style-type: none"> <li>■ Tank farms in refineries</li> <li>■ Ship loading terminals</li> <li>■ Marketing and distribution terminals</li> <li>■ Pipeline terminals</li> <li>■ Logistic terminals for tanks storing products like crude oils, refined white and black products, chemicals, LPG</li> </ul>

## Function and system design

<b>System design</b>	Tankvision Multi Scan is designed to act as gateway for legacy tank instrumentation into recent Tank Inventory software (e.g. Tankvision Professional) or control systems (DCS or PLC). Where required also the redundant collection and distribution of tank parameters is managed by Tankvision Multi Scan.
<b>System configuration</b>	<p>Tankvision Multi Scan is configured without any special software only by standard Microsoft Windows tools (Remote desktop). Network access to the Multi Scan is password protected.</p> <p>Configuration of connected tank gauges and sensors</p> <p>Different vendors' tools can be used to configure gauges by tunneling through the Multi Scan.</p>
<b>Features</b>	<ul style="list-style-type: none"> <li>■ Provides data Providing visualization software (e.g. Tankvision Professional) with the scanned parameters of tank gauges.</li> <li>■ Remote access Any PC with the specified requirements in the Intranet can be connected to Tankvision.</li> <li>■ Redundancy Hot standby with automatic switchover, various switching rules.</li> </ul>
<b>Features with limited functions</b>	<ul style="list-style-type: none"> <li>■ Representation of tank data Tank data can be represented graphically or in tables.</li> <li>■ Definition and management of products Product characteristics can be defined.</li> <li>■ Alarms Limit alarms (high-high, high, low, low-low and other programmable alarms) can be defined for measured certain tank parameters.</li> <li>■ Reports Reports can be sent to a printer (network printer or directly connected via USB) at scheduled time intervals or on demand.</li> <li>■ Graphical User Interface (GUI) Tankvision uses an intuitive and optimized user interface.</li> </ul>

<b>Security</b>	<p><b>IT security</b></p> <p>We only provide a warranty if the device is installed and used as described in the Operating Instructions. The device is equipped with security mechanisms to protect it against any inadvertent changes to the device settings.</p>
-----------------	---

IT security measures in line with operators' security standards and designed to provide additional protection for the device and device data transfer must be implemented by the operators themselves. Endress+Hauser can be contacted to provide support in performing this task.

## Typical system architecture

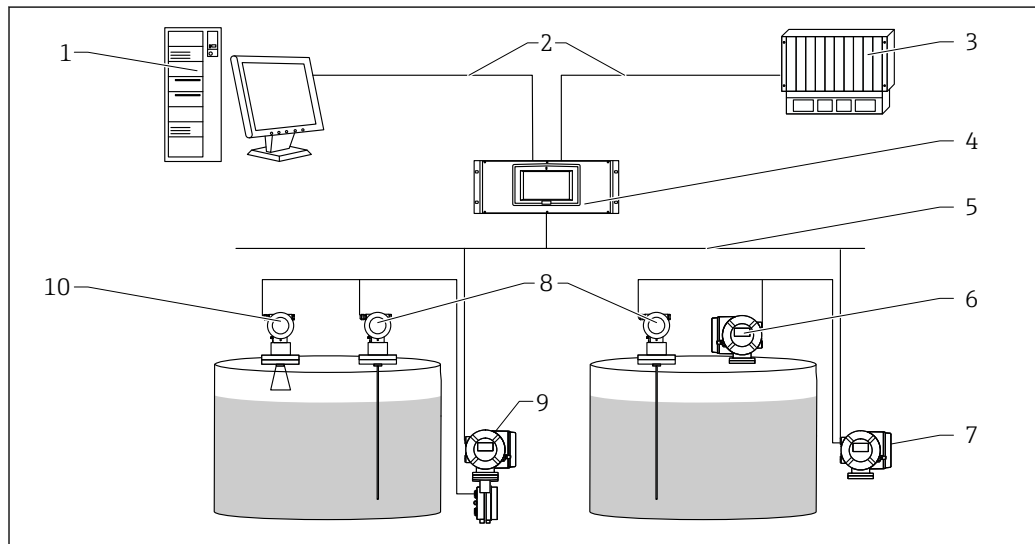

A0046351

- 1 Tankvision Professional NXA85 Workstation
- 2 Ethernet/Serial
- 3 DCS/PLC (Distributed control system/Programmable logic controlled)
- 4 Tankvision Multi Scan NXA83B
- 5 Fieldbus protocol (Modbus, Sakura V1, Whessoe WM550)
- 6 Proservo
- 7 Promonitor
- 8 Prothermo
- 9 Tank Side Monitor
- 10 Micropilot

**Tankvision Multi Scan in Switch By System redundancy mode**

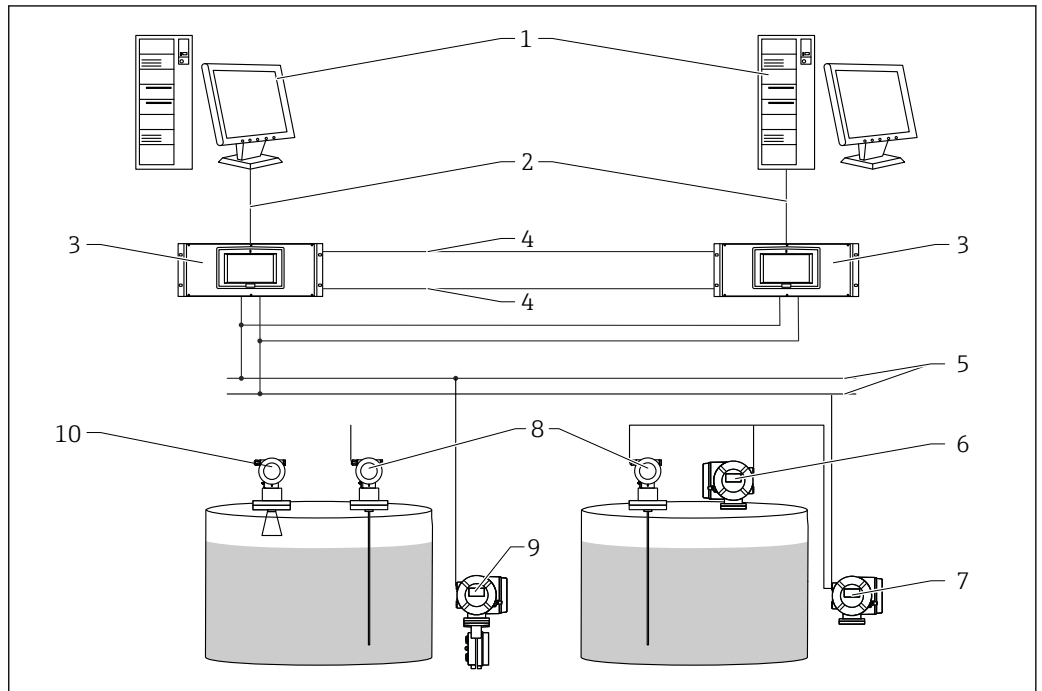

A0046352

- 1 Tankvision Professional NXA85 Workstation
- 2 Ethernet
- 3 Tankvision Multi Scan NXA83B
- 4 Control link RS-232 or Ethernet
- 5 Fieldbus protocol
- 6 Proservo
- 7 Promonitor
- 8 Prothermo
- 9 Tank Side Monitor
- 10 Micropilot

## Inputs and Outputs

**Power supply**

Supply voltage	Frequency	Power consumption	Current consumption
100 to 240 V <sub>AC</sub>	50 to 60 Hz	40 VA	max. 0.8 A

The Multi Scan contains a 20 x 5 mm cartridge fuse protecting the mains input. The fuse is rated at 3.15 A, time delay (ant surges/slow blow). The fuse is suitable for use at 240 V<sub>AC</sub>.

**Interfaces**

The Multi Scan is available in the following versions:

- 1 to 4 serial ports
- 1 to 12 serial ports
- 1 to 20 serial ports (16 in or outputs and 4 outputs)

The ports can be configured to be either inputs (from the field/host ports) or outputs (to host systems/ slave ports). For the version 1 to 20 serial ports, 4 ports are reserved for outputs only.

Multi Scan support the following electrical interfaces:

- RS-232
- RS-485
- Bi-Phase Mark
- Current Loop

In addition 2 Ethernet ports with up to 5 connections and 2 USB ports are also provided.

Multi Scan has an LED module, one pair for each of the serial ports, to indicate communication activity. One LED indicates transmission and the other one indicates the receipt of data.

Non isolated (bus ground = Multi Scan chassis ground):  
RS-232

Optocoupler isolated:

- RS-485
- Current Loop (GPE/Whessoe)
- L&J
- Varec

Transformer isolated:

- Enraf BPM
- "SAAB"/Rosemount TRL/2

---

#### Supported Input protocols (from the field)

- Modbus RS-485/RS-232, max. 15 gauges
- Modbus Ethernet
- Sakura V1, max. 10 gauges
- Whessoe WM550, max. 15 gauges
- Protocol compatible to Enraf GPU (Bi-Phase Mark), max. 8 gauges
- Protocol compatible to Saab TRL/2, max. 8 gauges
- Protocol compatible to VAREC Mark/Space, max. 15 gauges
- Protocol compatible to Scientific Instruments (RS-485), max. 15 gauges
- Protocol compatible to Tokyo Keiso (FW9000), max. 15 gauges

Additional protocols and variants upon request.

---

#### Device support

The Multi Scan is designed to interface to the following gauge and transmitter types.

Endress+Hauser:

Micropilot S + Tank Side Monitor, Micropilot NMR81, Micropilot NMR84, Tank Side Monitor NRF590, Tank Side Monitor NRF81, Proservo NMS8, Proservo NMS80, Proservo NMS81

Enraf:

- 811 Servo Gauge
- 813 Mechanical Gauge Transmitter
- 854 Servo Gauge
- 872 Radar Gauge
- 873 Radar Gauge
- 865 Temperature Selector

Whessoe:

- 1311 Transmitter/1071 Outstation
- 1315 Transmitter/2006 Mechanical float gauge, 1140 Servo gauge
- ITG 50/60/70 Servo gauges

Emerson:

TRL2, Rex, Raptor, Pro Radar Gauges

Varec:

1800/1900 Mark/Space Transmitters

Other devices supported upon request.

A range of gauge commands are supported but the availability of these commands depends on the gauge types.

The host and field communication parameters are configurable, however, a number of the above devices operate with fixed parameters.

---

#### Supported output/ communication (to host system)

- Native driver to connect to Tankvision Professional (Ethernet, RS-485, RS-232)
- Modbus (RS-485, RS-232, Ethernet)
- OPC DA Server to connect to Clients using version 1.0, 2.0, 3.0 (Ethernet)

Additional protocols and variants upon request.

## Environment

---

#### Mounting location

Indoor

<b>Ambient temperature</b>	0 to +40 °C (+32 to +104 °F)
<b>Storage temperature</b>	0 to +70 °C (+32 to 158 °F)
<b>Relative humidity</b>	Maximum 90 % at +25 °C (+77 °F) (non-condensing)
<b>Electromagnetic compatibility (EMC)</b>	EMC according to the requirements of the EN 61326-series and the NAMUR-recommendation EMC (NE21). Details can be found in the Declaration of Conformity.

## Mechanical construction

### Dimensions

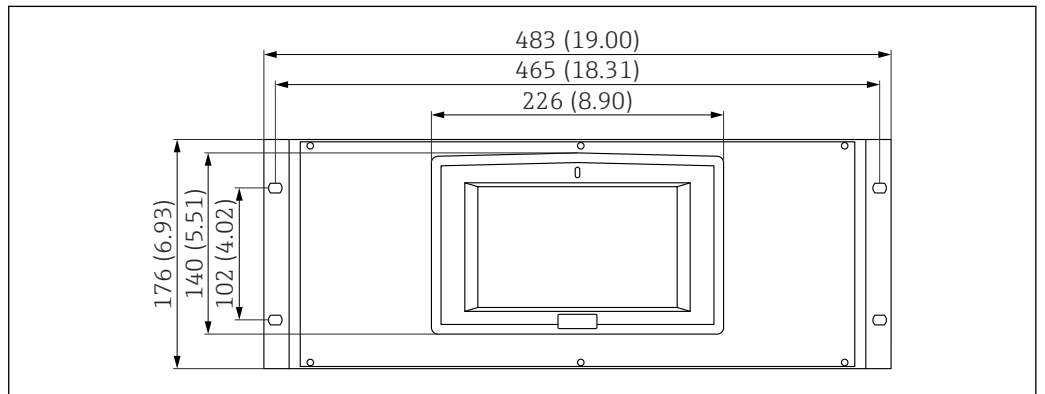

A0046364

### Backplane assembly variant 4 channels

The rack mount version is housed in an aluminum 4U 19 in case, which has 4 front fixing holes suitable for M6 bolts.

All power and signal connectors are located on the rear panel of the enclosure.

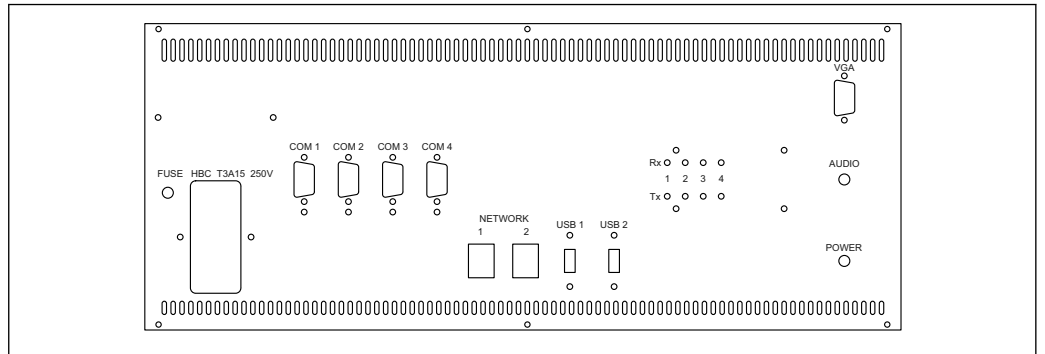

A0046361

Depth of enclosure: 315 mm

### Backplane assembly variant 12 channels

The rack mount version is housed in an aluminum 4U 19 in case, which has 4 front fixing holes suitable for M6 bolts.

All power and signal connectors are located on the rear panel of the enclosure.

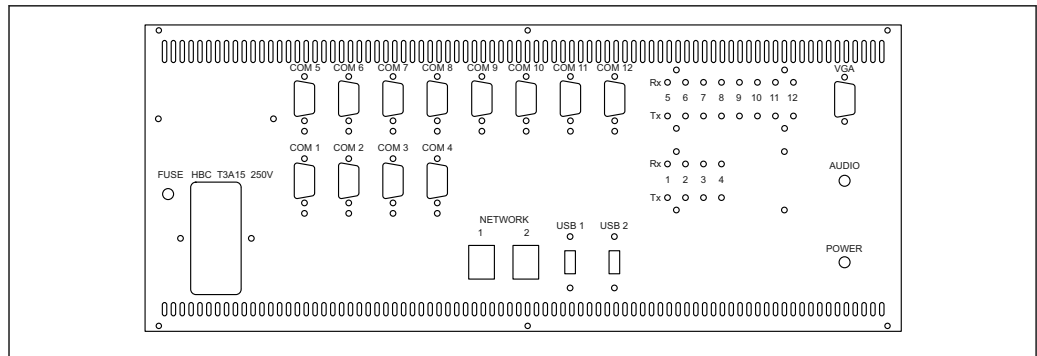

A0046362

Depth of enclosure: 315 mm

**Backplane assembly variant  
20 channels**

The rack mount version is housed in an aluminum 4U 19 in case, which has 4 front fixing holes suitable for M6 bolts.

All power and signal connectors are located on the rear panel of the enclosure.

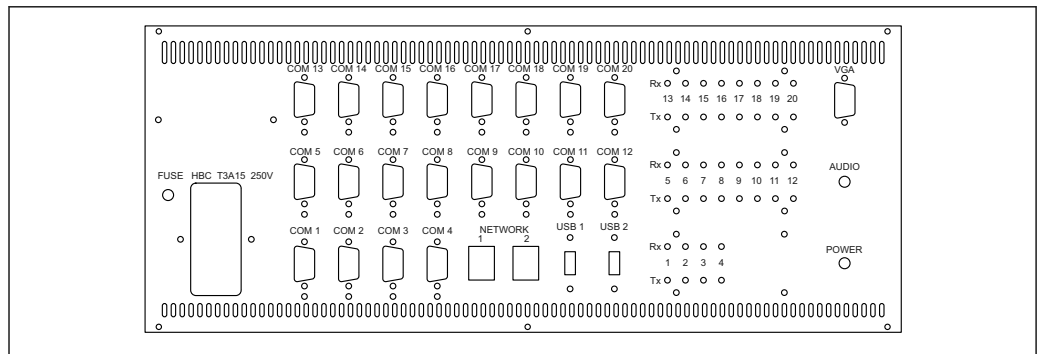

A0046363

Depth of enclosure: 315 mm

**Embedded human interface with limited functions**

**LCD display (optional)**

The Multi Scan is available with a 178 mm (7.01 in) widescreen LCD screen built into the front of the device, with navigation via a touch screen.

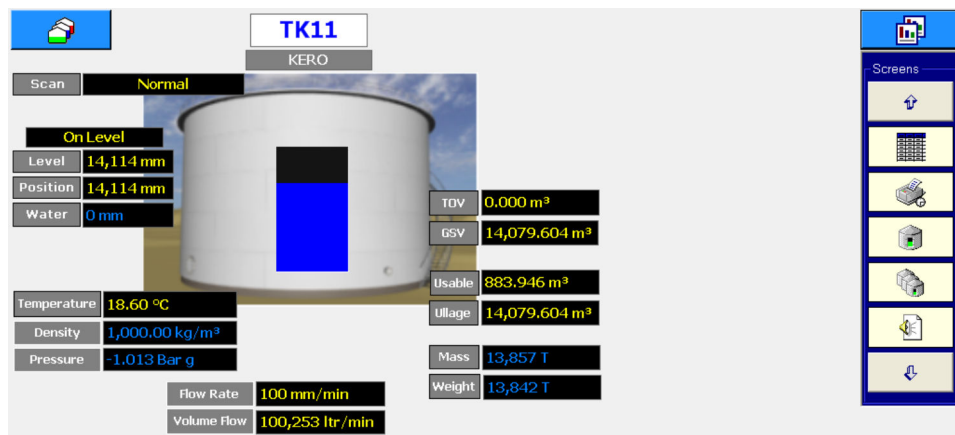

1 Single Tank View





GridView					
TankID	Product	Level mm	Temp. °C	TOV ltr	Gauge Status
TK1	BUTANE	2,322	18.60	2,321,700	On Level
TK10	PREM	11,320	18.60	11,320,300	On Level
TK11	KERO	12,320	18.60	12,320,300	On Level
TK12	ADDATIVE	13,322	18.60	13,321,900	On Level
TK13	BUTANE	14,322	18.60	14,321,900	On Level
TK14	EMPTY	15,322	18.60	15,321,900	On Level
TK15	EMPTY	16,322	18.60	16,321,900	On Level
TK2	KERO	16,677	18.60	16,677,201	On Level
TK3	BUTANE	4,323	18.60	4,323,400	On Level
TK4	PREM	5,323	18.60	5,323,200	On Level
TK5	DERV	5,662	18.60	5,661,800	On Level
TK6	DERV	4,677	18.60	4,676,800	On Level
TK7	DERV	5,675	18.60	5,675,100	On Level
TK8	PREM	9,325	18.60	9,325,200	On Level
TK9	DERV	7,680	18.60	7,679,900	On Level
Totals				144,592,50	

2 Grid View

**Remote desktop**

The Remote desktop is used for configuration purpose only. It is offering a standard Windows operating user interface.

## Installation considerations

 It is recommended to take the information contained in the Operating Instructions into consideration when designing the system architecture. →  10

**System requirements of user PC**

Check the latest information on hardware and software requirements. Please contact your local Endress+Hauser Sales Center.

**Network requirements**

Network switches must always be used to interconnect Tankvision components. Network hubs must never be used.

Only use screened cables (Category 5 or higher).

**NOTICE**

**EMC requirements**

The legal EMC requirements are fulfilled only when

- ▶ a screened LAN cable is used and
- ▶ the cable screen is properly terminated to screened RJ45 connectors.

**NOTICE**

**Harsh environments**

Most commercial and IT infrastructure networking switches (and components) are not designed to be used within harsh environments (e.g. temperatures below +5 °C (+41 °F), dusty or with high levels of EMC or electrical noise).

- ▶ It is therefore recommended that only networking components specifically designed for industrial control purposes be used within the control room (or control cabinet) environment as part of the Tankvision system.

**Shielding and Grounding**

When planning the shielding and grounding for a fieldbus system, there are 3 important points to consider:

- Electromagnetic compatibility (EMC)
- Explosion protection
- Safety of the personnel

To ensure the optimum electromagnetic compatibility of systems, it is important that the system components and above all cables, which connect the components, are shielded and that no portion of the system is unshielded. Ideally, the cable shields are connected to the normally metal housings of the connected field devices. Since these are generally connected to the protective earth, the shield of the bus cable is grounded many times. Keep the stripped and twisted lengths of cable shield to the terminals as short as possible.

This approach, which provides the best electromagnetic compatibility and personnel safety, can be used without restriction in systems with good potential equalization.

In the case of systems without potential equalization, a power supply frequency (50/60 Hz) equalizing current can flow between two grounding points which, in unfavourable cases, e.g. when it exceeds the permissible shield current, may destroy the cable.

To suppress the low frequency equalizing currents on systems without potential equalization, it is therefore recommended to connect the cable shield directly to the building ground (or protective earth) at one end only and to use capacitive coupling to connect all other grounding points.

#### **NOTICE**

##### **EMC requirements**

The legal EMC requirements are fulfilled only when

- ▶ the cable shield is grounded on both sides!

## Certificates and approvals

### CE mark

The measuring system meets the legal requirements of the EC-guidelines.

Endress+Hauser confirms the instrument passing the required tests by attaching the CE-mark.

## Ordering information

Detailed ordering information is available from the following sources:

- In the Product Configurator on the Endress+Hauser website: [www.endress.com](http://www.endress.com) ->Select country ->Instruments ->Select device ->Product page function: Configure this product
- From your Endress+Hauser Sales Center: [www.endress.com/worldwide](http://www.endress.com/worldwide)



#### **Product Configurator - the tool for individual product configuration**

- Up-to-the-minute configuration data
- Depending on the device: Direct input of measuring point-specific information such as measuring range or operating language
- Automatic verification of exclusion criteria
- Automatic creation of the order code and its breakdown in PDF or Excel output format
- Ability to order directly in the Endress+Hauser Online Shop

## Documentation

### Operating Instructions

#### **BA01288G**

Operation manual

#### **BA01290G**

Installation and Maintenance manual

#### **BA01291G**

Configuration manual

#### **BA01292G**

DCC Communications Configuration

#### **BA01289G**

OPC Tank Data Server

**BA01287G**

Weights and Measures Additions

**BA01296G**

Redundancy manual

## Registered trademarks

---

**Modbus™**

Modbus is a registered trademark of Schneider Electric USA, Inc.

---

**Microsoft, Windows,  
Silverlight**

Microsoft, Windows and Silverlight are registered trademarks of the Microsoft Corporation

---

**HART®**

Registered trademark of HART Communication Foundation, Austin, USA

---

**Varec®**

Registered trademark of Varec, Inc. Copyright 2003

---

**Others**

Enraf, Honeywell, Rosemount, Emerson, Saab, L&J, GPE are registered trademarks and trademarks of these organizations and companies.

All other marks are property of their respective owners.



71552018

[www.addresses.endress.com](http://www.addresses.endress.com)

---