

# Brief Operating Instructions Prosonic M FMU44 HART

Ultrasonic measuring technology



These Instructions are Brief Operating Instructions; they are not a substitute for the Operating Instructions pertaining to the device.

Detailed information about the device can be found in the Operating Instructions and the other documentation:

Available for all device versions via:

- Internet: [www.endress.com/deviceviewer](http://www.endress.com/deviceviewer)
- Smart phone/tablet: *Endress+Hauser Operations App*

# 1 Associated documentation



A0023555

## 2 About this document

### 2.1 Symbols

#### 2.1.1 Safety symbols

**⚠ DANGER**

This symbol alerts you to a dangerous situation. Failure to avoid this situation will result in serious or fatal injury.

**⚠ WARNING**

This symbol alerts you to a dangerous situation. Failure to avoid this situation can result in serious or fatal injury.

#### CAUTION

This symbol alerts you to a dangerous situation. Failure to avoid this situation can result in minor or medium injury.

#### NOTICE

This symbol contains information on procedures and other facts which do not result in personal injury.

### 2.1.2 Electrical symbols

 Ground connection

Grounded clamp, which is grounded via a grounding system.

 Protective earth (PE)

Ground terminals, which must be grounded prior to establishing any other connections. The ground terminals are located on the inside and outside of the device.



Temperature resistance of the connection cables

Minimum value for the temperature resistance of the connection cables

### 2.1.3 Symbols for certain types of information and graphics

 Permitted

Procedures, processes or actions that are permitted.

 Forbidden

Procedures, processes or actions that are forbidden.



Tip

Indicates additional information.

 Reference to documentation

**1.**, **2.**, **3.** Series of steps

**L**➤ Result of an individual step

1, 2, 3 ... Item numbers

## 3 Basic safety instructions

### 3.1 Requirements for the personnel

To carry out their tasks, such as commissioning or maintenance, personnel must meet the following requirements:

- ▶ Trained specialists must have a qualification that is relevant to the specific function and task.

- ▶ Must be authorized by the plant owner/operator.
- ▶ Must be familiar with national regulations.
- ▶ Must have read and understood the instructions in the manual and supplementary documentation.
- ▶ Must follow instructions and comply with general policies.

## 3.2 Intended use

Compact measuring device for continuous, non-contact level measurement. The measuring range is up to 20 m (66 ft) for liquids and up to 10 m (33 ft) for bulk solids. Flow measurements can be carried out in open flumes and weirs with the linearization function.

## 3.3 Workplace safety

When working on and with the device:

- ▶ Wear the required protective equipment according to federal/national regulations.

## 3.4 Operational safety

Risk of injury!

- ▶ Operate the device only if it is in proper technical condition, free from errors and faults.
- ▶ The operator is responsible for the trouble-free operation of the device.

### Modifications to the device

Unauthorized modifications to the device are not permitted and can lead to unforeseeable dangers.

- ▶ If modifications are nevertheless required, consult with Endress+Hauser.

### Repair

To ensure continued operational safety and reliability:

- ▶ Only perform repair work on the device if this is expressly permitted.
- ▶ Observe federal/national regulations pertaining to the repair of an electrical device.
- ▶ Use original spare parts and accessories from Endress+Hauser only.

## 3.5 Product safety

This device has been constructed and tested to state-of-the-art operational safety standards and in accordance with good engineering practice. The device left the factory in a safe operating condition.

### 3.5.1 CE mark

The device meets the legal requirements of the applicable EU Directives. These are listed in the corresponding EU Declaration of Conformity along with the standards applied. Endress+Hauser confirms successful testing of the device by affixing to it the CE mark.

### 3.5.2 EAC conformity

The device meets the legal requirements of the applicable EAC Directives. These are listed in the corresponding EAC Declaration of Conformity along with the standards applied. Endress+Hauser confirms successful testing of the device by affixing to it the EAC mark.

## 4 Incoming acceptance and product identification

### 4.1 Incoming acceptance

Check the following during goods acceptance:

- Are the order codes on the delivery note and the product sticker identical?
- Are the goods undamaged?
- Do the nameplate data match the ordering information on the delivery note?
- If necessary (see nameplate), are the Safety Instructions, e. g. XA, provided?



If one of these conditions is not satisfied, contact your Sales Center.

### 4.2 Product identification

Nameplate data on the device

- ▶ Enter the serial number of the nameplates into *W@M Device Viewer* [www.endress.com/deviceviewer](http://www.endress.com/deviceviewer)
  - ↳ All information about the measuring device and the scope of the associated Technical Documentation is displayed.
- ▶ Enter the serial number from the nameplate in the *Endress+Hauser Operations app*.
  - ↳ All information about the measuring device and the scope of the associated Technical Documentation is displayed.

#### 4.2.1 Manufacturer address

Endress+Hauser SE+Co. KG  
Hauptstraße 1  
79689 Maulburg, Germany

Place of manufacture: See nameplate.

## 4.3 Incoming acceptance and product identification

### 4.3.1 Incoming acceptance

Check the following during goods acceptance:

- Are the order codes on the delivery note and the product sticker identical?

- Are the goods undamaged?
- Do the nameplate data match the ordering information on the delivery note?
- If necessary (see nameplate), are the Safety Instructions, e. g. XA, provided?



If one of these conditions is not satisfied, contact your Sales Center.

#### 4.3.2 Product identification

The following options are available for identification of the device:

- Nameplate specifications
- Extended order code with breakdown of the device features on the delivery note
- ▶ Enter serial number from nameplates in *W@M Device Viewer* ([www.endress.com/deviceviewer](http://www.endress.com/deviceviewer))
  - ↳ All of the information on the measuring device and on the scope of the technical documentation pertaining to the device is displayed.
- ▶ Enter the serial number from the nameplate into the *Endress+Hauser Operations App* or scan the 2-D matrix code on the nameplate.
  - ↳ All of the information on the measuring device and on the scope of the technical documentation pertaining to the device is displayed.

#### 4.3.3 Manufacturer address

Endress+Hauser SE+Co. KG

Hauptstraße 1

79689 Maulburg, Germany

Place of manufacture: See nameplate.

#### 4.3.4 Storage and transport

- Pack the measuring device so that it is protected against impact.  
The original packaging offers the best protection
- Permitted storage temperature: -40 to +80 °C (-40 to 176 °F)

#### Transporting the product to the measuring point



**The housing or flange can be damaged.**

Risk of injury!

- ▶ Transport the measuring device to the measuring point in its original packaging or by the process connection.
- ▶ Always secure lifting equipment (belts, lugs, etc.) at the process connection, while paying attention to the center of gravity of the device to ensure that the device does not tilt or slip.
- ▶ Follow the safety instructions and transport conditions for devices weighing more than 18 kg (39.6 lb) (IEC 61010).

## 5 Mounting

### 5.1 Mounting requirements

#### 5.1.1 Installation conditions for sensor for level measurements

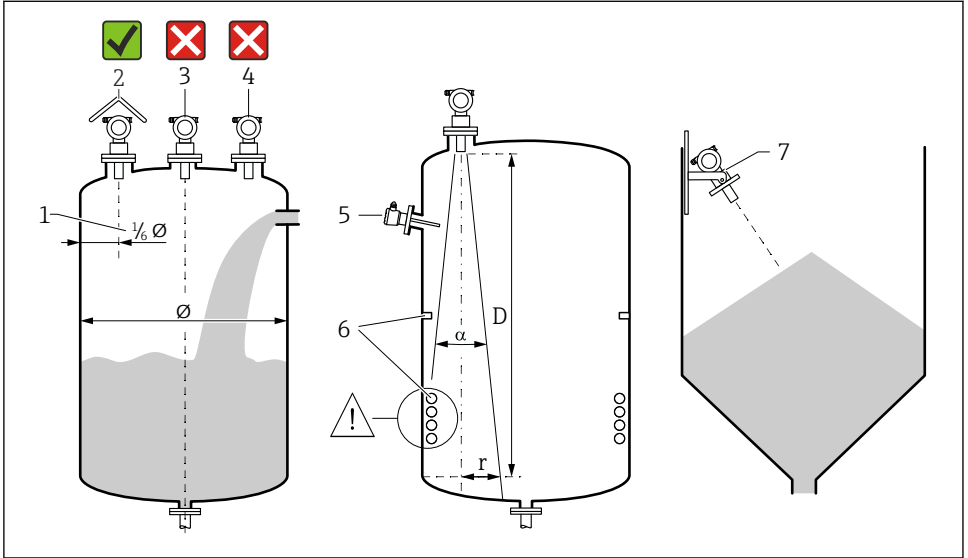

A0038210

#### 1 Installation conditions

- 1 Distance to vessel wall:  $\frac{1}{6}$  of vessel diameter
- 2 Use of a weather protection cover; protection from direct sunlight or rain
- 3 Do not install the sensor in the middle of the vessel.
- 4 Avoid measurements through the filling curtain.
- 5 Do not install limit switches or temperature sensors inside the beam angle.
- 6 Measurement is affected by symmetrical fittings, e.g. heating coils and baffles.
- 7 Position the sensor so that it is perpendicular to the product surface.

- Install only one device per vessel: signals from multiple devices will interfere with each other.
- Determine the detection range using a 3 dB beam angle  $\alpha$ .

Further information is available in the Operating Instructions.

#### 5.1.2 Installation conditions for the sensor for flow measurements

- Mount the measuring device on the upstream side immediately above the maximum upper water level  $H_{\max}$
- Take the blocking distance into account
- Position the measuring device in the center of the flume or weir

- Align the sensor membrane so that it is parallel to the surface of the water
- Observe the installation clearance of the flume or weir
- Enter the "flow - level" ("Q/h curve") linearization curve via the FieldCare operating program or manually via the local display

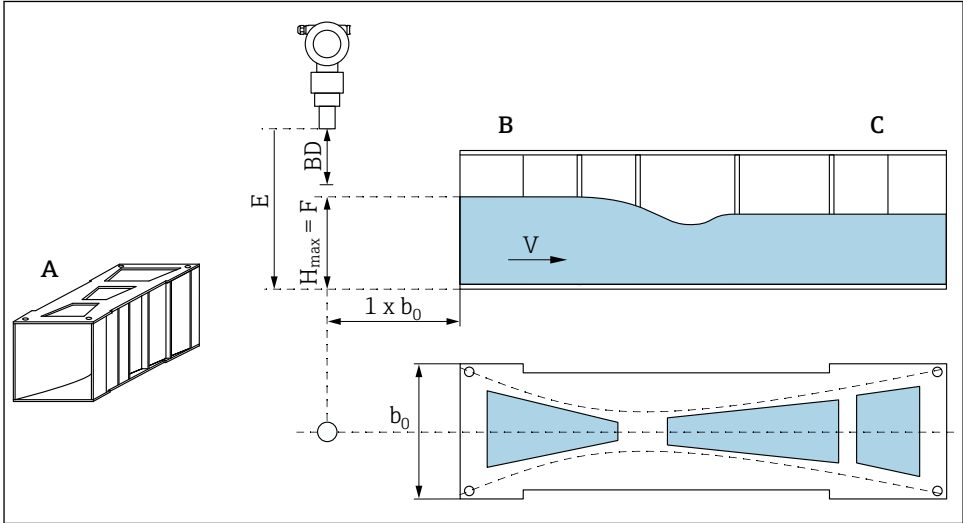

A0038222

2 Khafagi-Venturi flume (example)

- A Khafagi-Venturi flume
- B Upstream side
- C Downstream side
- BD Blocking distance of the sensor
- E Empty calibration (enter during commissioning)
- $H_{max}$  Maximum upstream level
- V Flow
- $b_0$  Width of Khafagi-Venturi flume



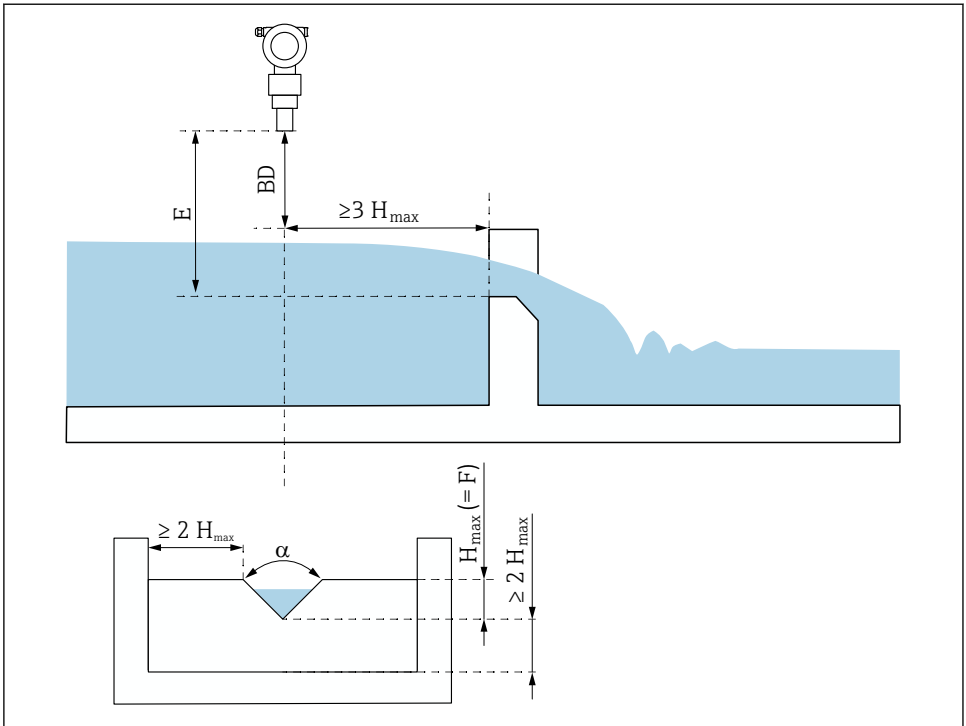

A0038223

3 Triangular weir (example)

*BD* Blocking distance of the sensor

*E* Empty calibration (enter during commissioning)

*F* Full calibration

*H<sub>max</sub>* Maximum upstream level

### 5.1.3 Mounting examples

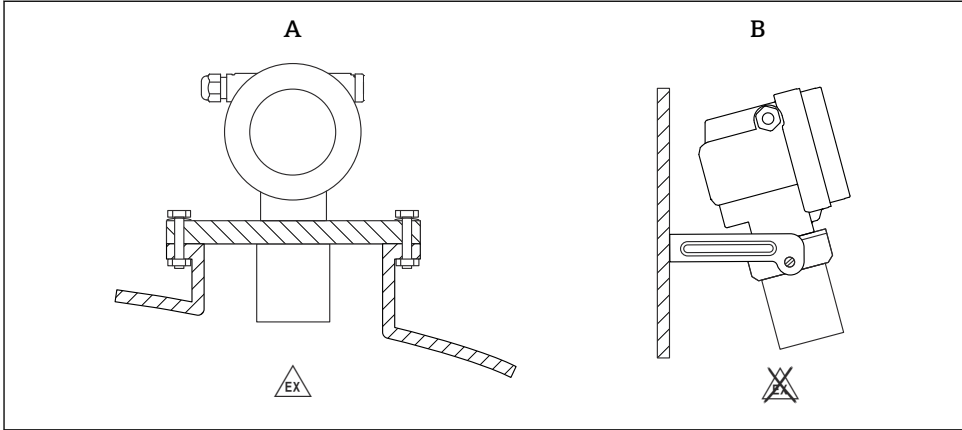

A0038822

#### 4 Mounting examples

- A Mounting with universal flange (e.g. hazardous area, Zone 20)  
 B Mounting with mounting bracket (non-hazardous area, Zone 20)

### 5.1.4 Turning the housing

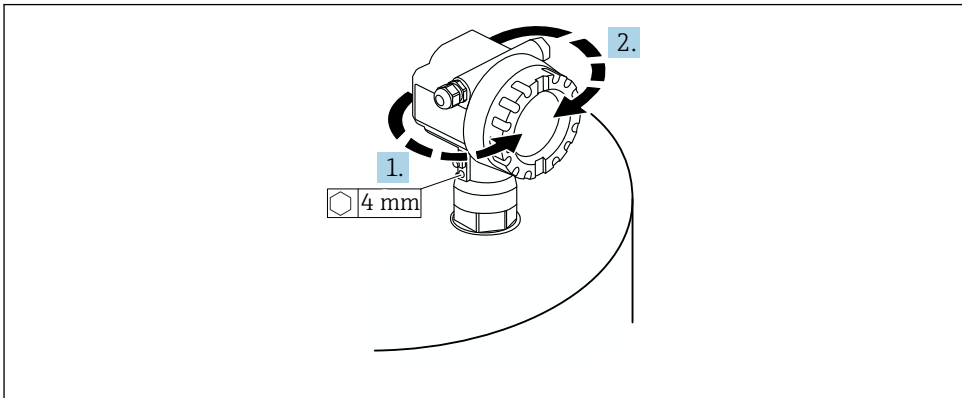

A0037777

#### 5 Turning the F12 or T12 housing, (F12 housing in example)

1. Loosen the securing screw.
2. Rotate the housing in the desired direction, maximum 350°.
3. Tighten the securing screw, maximum torque 0.5 Nm (0.36 lbf ft).
4. Lock the securing screw; use a glue specifically for metal.

## 5.2 Measuring range

### 5.2.1 Sensor features

- Beam angle ( $\alpha$ ): 11°
- Blocking distance (BD): 0.5 m (1.6 ft)
- Maximum range for liquids: 20 m (66 ft)
- Maximum range for bulk solids: 10 m (33 ft)

### 5.2.2 Blocking distance

#### NOTICE

**If the blocking distance is undershot, this may cause a device malfunction.**

- ▶ Mount the measuring device high enough that the blocking distance is not reached at the maximum fill level.
- ▶ Define the safety distance (SD).
- ▶ If the level enters the safety distance SD, the device generates a warning or alarm.
- ▶ The measuring span F may not project into the blocking distance BD. Level echoes within the blocking distance cannot be evaluated due to the transient response of the sensor.

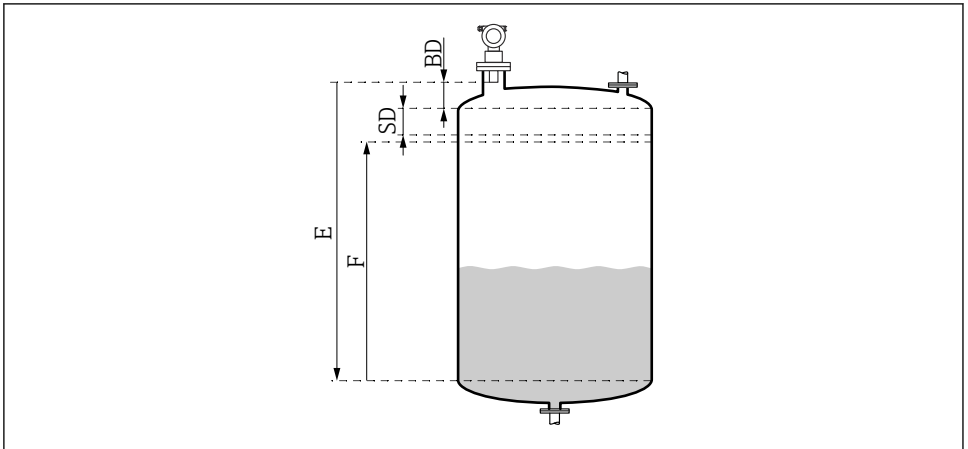

A0038238

6 Parameter for the correct operation of the device

BD Blocking distance

SD Safety distance

E Empty calibration

F Span



If the blocking distance cannot be maintained, use a pipe nozzle.

More information can be found in the Operating Instructions and in the Technical Data document.

### 5.2.3 Safety distance

The device generates a warning or alarm if the level reaches the safety distance (SD). The SD size can be set as required by the user in the **Safety distance (015)** function.

In the **In safety dist. (016)** function define how the device should react if the safety distance is undershot.

Options and meaning

- **Warning**

The measuring device displays an error message but keeps measuring.

- **Alarm**

The measuring device displays an error message.

The output signal in the **Output on alarm (011)** function displays the defined value.

As soon as the level drops below the safety distance, the device resumes measuring.

- **Self holding**

The measuring device responds in the same way as for an alarm.

However, the alarm condition is maintained even if the level drops below the safety distance again.

The device only starts measuring again when the user cancels the alarm using the

**Acknowledge alarm (017)** function.

## 6 Electrical connection

### 6.1 Connecting requirements

#### **WARNING**

**Risk of explosion due to faulty connection.**

- ▶ Observe applicable national standards.
- ▶ Comply with the specifications in the Safety Instructions (XA).
- ▶ Check to ensure that the supply voltage matches the information on the nameplate.
- ▶ The specified cable gland must be used.
- ▶ Switch off the supply voltage before connecting.
- ▶ Connect the potential equalization line to the outer ground terminal before applying the supply voltage.
- ▶ When connecting to the public mains, install a mains switch for the device such that it is within easy reach of the device. Mark the switch as a disconnecter for the device (IEC/EN61010).

## 6.2 Connecting the device

### 6.2.1 Connection in the F12 housing

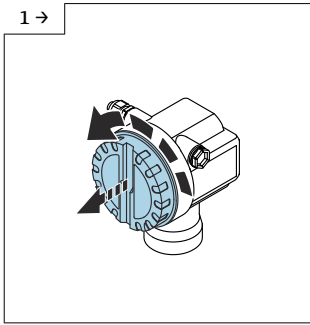

- ▶ Unscrew the cover

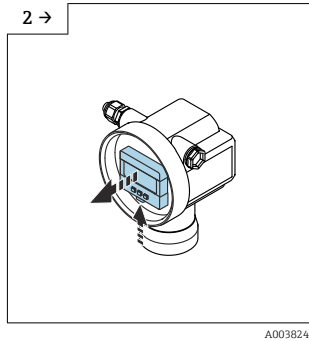

- ▶ Remove the display if one is fitted

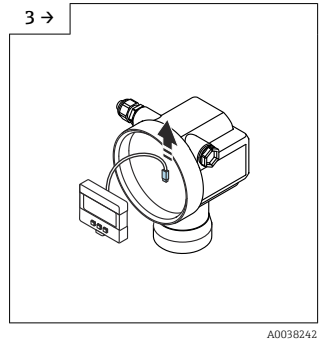

- ▶ Remove the cable from the display

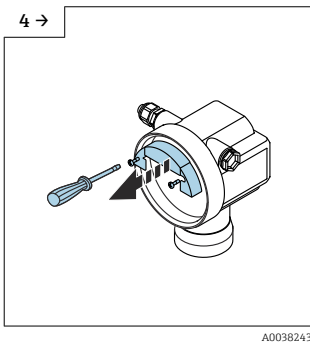

- ▶ Pull out the terminal module slightly using the pull loop

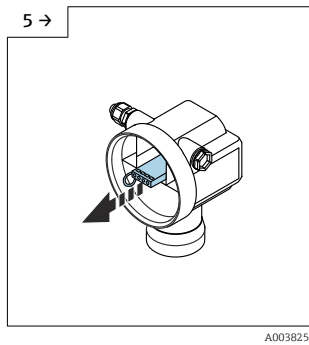

- ▶ Avoid moisture in the housing, provide a loop to allow moisture to drain off

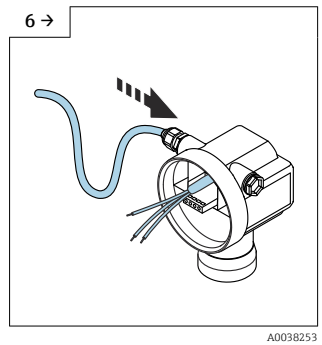

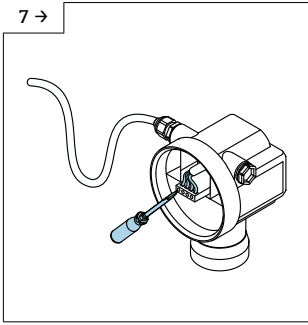

A0038254

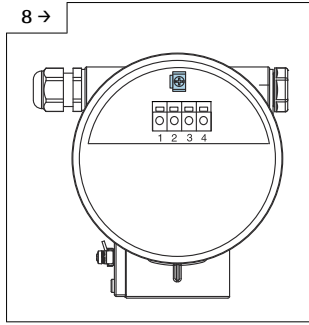

A0038706

► Connect the cable shield to the ground terminal in the connection compartment

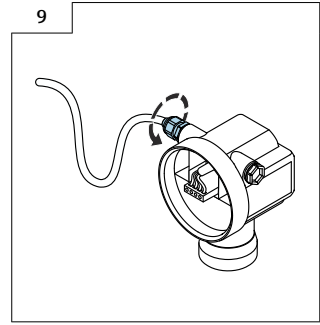

A0047499

► Tighten the cable gland

10. Close the connection compartment.

11. Switch on the power supply.

### 6.2.2 Connection in the T12 housing

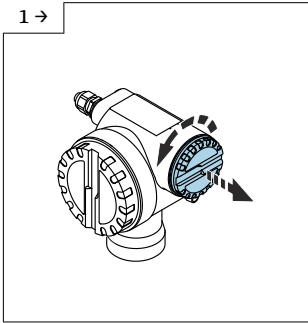

A0038256

► Unscrew the cover

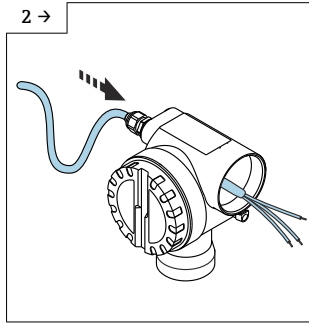

A0038257

► Avoid moisture in the housing, provide a loop to allow moisture to drain off

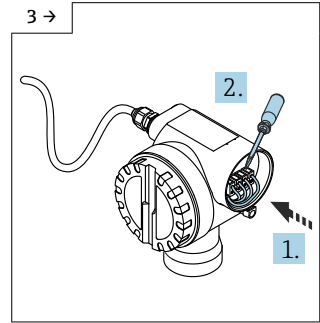

A0038258

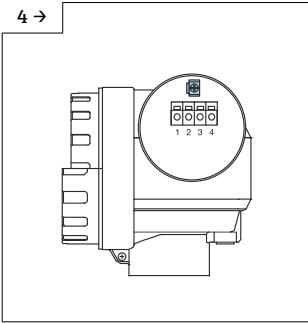

A0038711

- ▶ Connect the cable shield to the ground terminal in the connection compartment

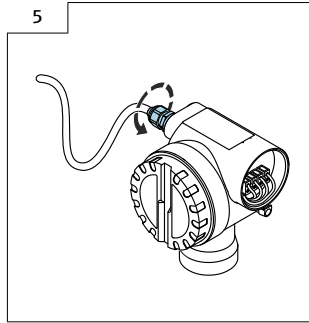

A0047500

- ▶ Tighten the cable gland.

- 6. Close the housing.
- 7. Switch on the power supply.

### 6.3 Terminal assignment

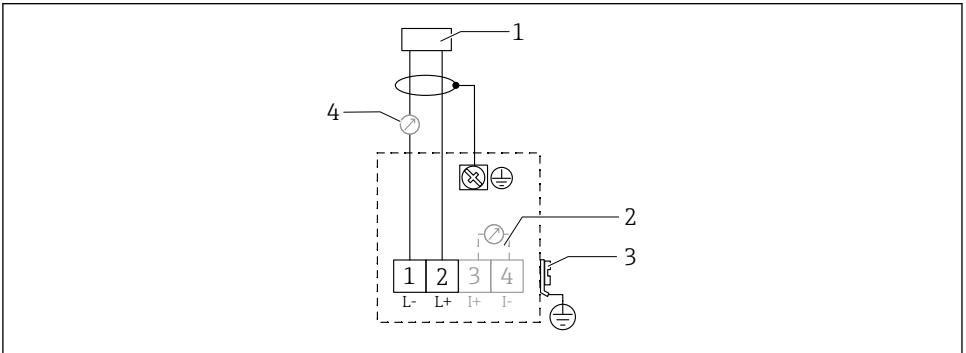

A0019269

**7** Terminal assignment for two-wire version

- 1 Supply voltage
- 2 Test terminal to test the signal current
- 3 PAL (potential equalization)
- 4 4-20 mA HART

- ▶ Connect the connecting line to the screw terminals in the connection compartment (conductor cross-section 0.5 to 2.5 mm<sup>2</sup>, 20 to 14 AWG)

- ▶ A standard device cable suffices if only the analog signal should be used. Use a shielded cable if working with a superimposed communication signal (HART).



Protective circuits against reverse polarity, RF influences and overvoltage peaks are integrated in the device.

Operation via handheld terminal or PC with operating program: take minimum communication resistance of 250  $\Omega$  and maximum load into consideration

- Superimposed communication signal (HART): use a shielded cable
- Analog signal: use a standard installation cable
- For other connections: use Commubox FXA291 or Field Xpert

## 6.4 Supply voltage

### 6.4.1 Two-wire version, HART

Terminal voltage directly at the device

#### Standard

- Current consumption 4 mA | terminal voltage 14 to 36 V
- Current consumption 20 mA | terminal voltage 8 to 36 V

#### Ex ia

- Current consumption 4 mA | terminal voltage 14 to 30 V
- Current consumption 20 mA | terminal voltage 8 to 30 V

#### Ex d

- Current consumption 4 mA | terminal voltage 14 to 30 V
- Current consumption 20 mA | terminal voltage 11 to 30 V

#### Fixed current, terminal voltage directly at the device

User-configurable, e.g. for solar powered operation (measured value via HART)

#### Standard

Current consumption 11 mA | terminal voltage 10 to 36 V

#### Ex ia

Current consumption 11 mA | terminal voltage 10 to 30 V

#### Fixed current for Multidrop mode

#### Standard

Current consumption 4 mA | (start-up current: 11 mA), terminal voltage 14 to 36 V

#### Ex ia

Current consumption 4 mA | (start-up current: 11 mA), terminal voltage 14 to 30 V



## 6.5 Potential equalization

### NOTICE

The housing is isolated from the tank by the plastic sensor. Because of this, interference signals may occur if the potential equalization line is not properly connected.

- ▶ Use a short potential equalization line for optimum electromagnetic compatibility.
- ▶ Minimum line cross-section  $2.5 \text{ mm}^2$  (14 AWG).



Use a ground strap if interference can be expected due to the installation conditions (existing interfering installations).

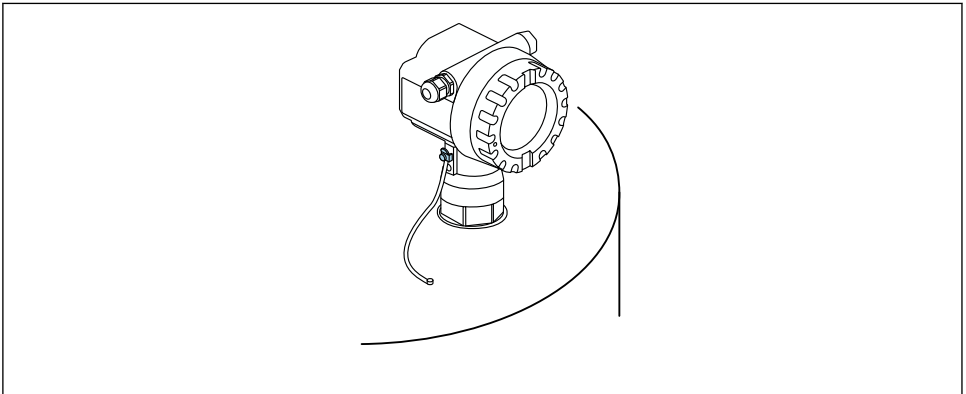

A0038292

8 Position of outer ground terminal, example of F12 housing

- Connect the potential equalization line to the outer ground terminal of the transmitter
- In the case of hazardous area applications, only ground on the sensor side
- Comply with the specifications in the Safety Instructions

## 7 Operation options

### 7.1 Overview of operation options

- Local operation
- HART communication
  - Further information is available in the Operating Instructions.

### 7.2 Structure and function of the operating menu

#### 7.2.1 Function codes

Within the function menus, a position is shown on the display for each function.

The first two digits identify the function group, examples:

- Basic setup: **00**
- Safety settings: **01**
- Linearization: **04**

The third digit refers to the individual functions within the function group, examples:

- Tank shape: **002**
- Medium property: **003**
- Process cond.: **004**

## 7.3 Access to operating menu via local display

### 7.3.1 Display

#### Measured value display

- Label, e.g. measured value
- Symbol, e.g. 
- Value and unit, e.g. 43.2 %
- Position in menu, e.g. 000
- Bar graph

The bar graph corresponds to the measured value. The bar graph is divided into 10 bars. Each fully filled bar corresponds to 10% of the set span.

#### Group selection

Picklist of function groups, e.g. basic setup, safety settings, temperature

#### Function with free parameter

- Label, e.g. empty calibration
- Help text
- Position in menu, e.g. 005

#### Envelope curve display

Envelope curve, view

#### Symbols

 ALARM\_SYMBOL

Device is in the alarm condition.

If the symbol flashes, this indicates a warning.

 LOCK\_SYMBOL

Device is locked. No other entries are possible.

 COM\_SYMBOL

Data transfer in progress.

#### Button functions

 or 

- Navigate upwards in the picklist.
- Edit the numeric values within a function.

⏏ or ⏏

- Navigate downwards in the picklist.
- Edit the numeric values within a function.

**Simultaneously** ⏏ ⏏

Navigate to the left within a function group.

⏏

- Navigate to the right within a function group.
- Confirm entry

**Simultaneously** ⏏ ⏏ or ⏏ ⏏

Set the contrast of the LCD

**Simultaneously** ⏏ ⏏ ⏏

Lock or unlock the hardware

ⓘ Further information is available in the Operating Instructions.

## 7.4 Locking/unlocking parameter configuration

ⓘ Further information is available in the Operating Instructions.

# 8 Commissioning

## 8.1 Switching on the device

After the supply voltage has been switched on, the device is first initialized. The following is then displayed for approx. five seconds:

- Device type
- Software version

Parameters the device asks for the first time it is switched on:

- **Language**  
Select the language of the display.
- **Length unit**  
Select length unit for measuring distance
- **Basic setup**  
Measured value is visible, which does not yet indicate the level in the tank  
Perform basic setup

## 8.2 Connecting via FieldCare

This section describes commissioning using the local display.

Commissioning via FieldCare is the same as with the onsite display.

## 8.3 Configuring the device

### 8.3.1 Basic setup

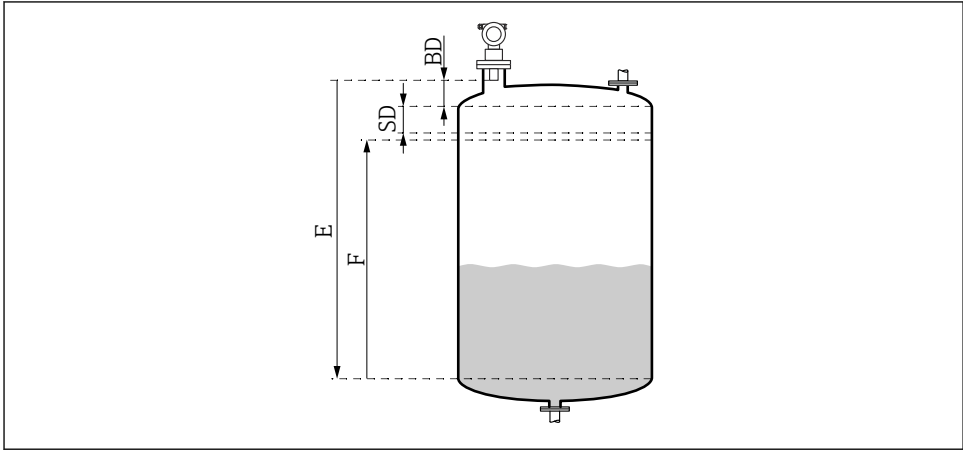

A0038238

#### 9 Parameters for the correct operation of the device

*BD* Blocking distance

*SD* Safety distance

*E* Empty calibration (= zero)

*F* Full calibration (= measuring span)

All the functions are grouped together in the **Basic setup (00)** function group. When you have completed your entries for a function, the next function appears automatically.

#### Basic setup procedure (example)

*Function and selection*

- **Tank shape** → Dome ceiling
- **Medium property** → Unknown
- **Process cond.** → Standard
- **Empty calibr.**
- **Full calibr.**
- **Mapping**

*Optional functions*

- **Safety settings**
- **Linearization**
- **Extended calibration**
- ...

#### Configuration of the measuring point

*Tank shape function (002)*

Selection

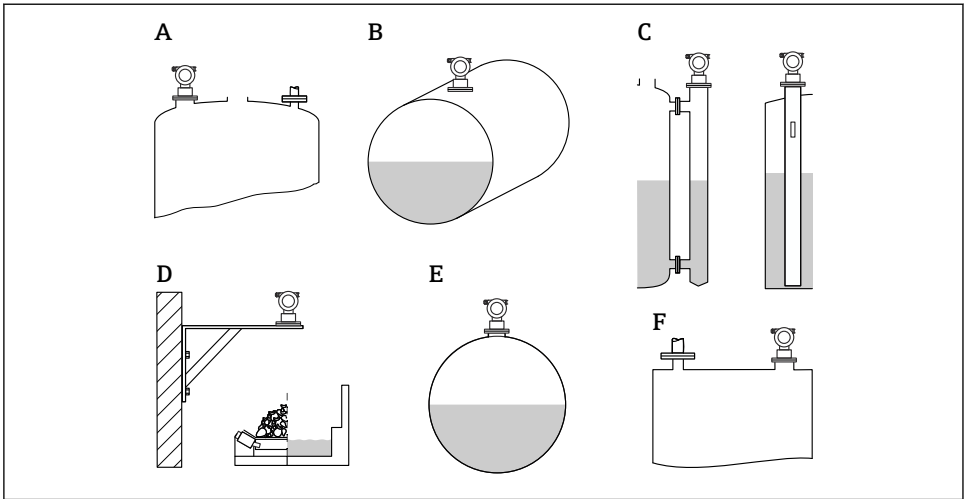

A0038388

#### 10 Options in the "Tank shape" function

- A Dome ceiling
- B Horizontal cyl
- C Bypass or stilling well/ultrasound guide pipe
- D No ceiling, e.g. dumps, open levels, basins, flume
- E Sphere
- F Flat ceiling

#### Medium properties function (003)

##### Selection

- Unknown (e.g. pasty media such as greases, creams, gels etc.)
- Liquid
- Bulk solids, grain size < 4 mm, powder
- Bulk solids, grain size > 4 mm, coarse

#### Process cond. function (004)

##### Selection

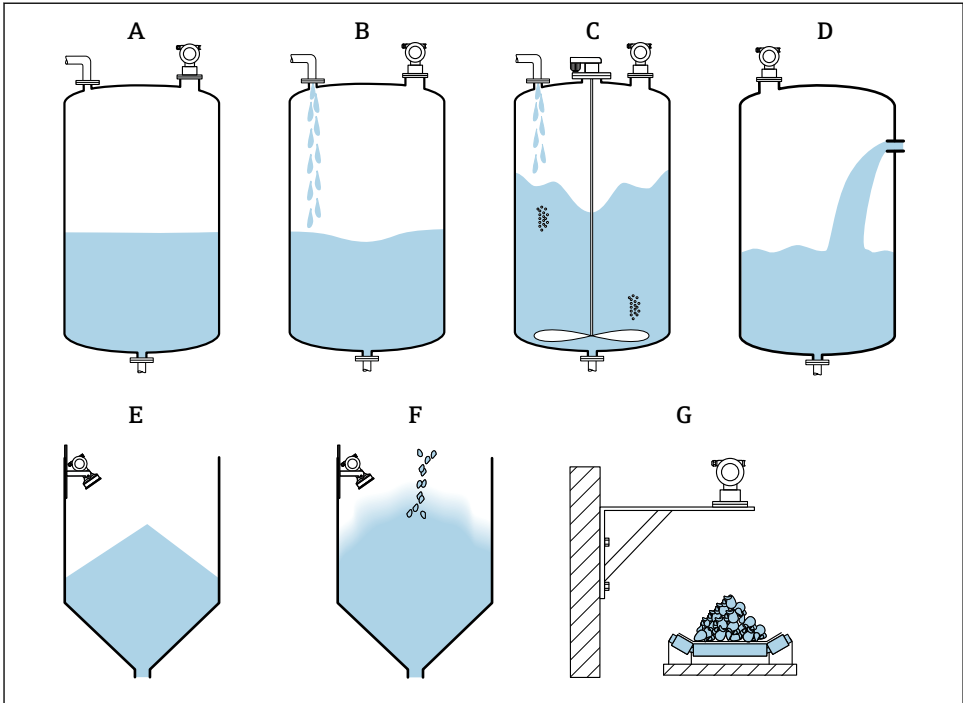

A0038402

11 Some of the options in the "Process cond." function

- A Calm surface
- B Turb. surface
- C Add. agitator
- D Fast change
- E Standard solid
- F Solid dusty
- G Conveyor belt
- Not in graphic: Standard liq. and Test: no filter

## Description of options

- **Standard liq.**
  - For liquid applications that do not suit any of the options
  - Average filter values and output damping
- **Calm surface**
  - For storage tanks with an immersion tube or bottom filling
  - Large filtering range and output damping
    - Stable measured value, accurate measurement, slow response time
- **Turb. surface**
  - For storage and buffer tanks with turbulent surfaces due to free filling, mixing nozzles or small bottom agitators
  - Emphasis on filters to stabilize the input signal
    - Steady measured value, medium response time
- **Add. agitator**
  - For agitated surfaces due to agitators, e.g. vortex formation
  - Large values are set for filters to stabilize the input signal
    - Steady measured value, medium response time
- **Fast change**
  - For fast changes in the level, particularly in small tanks
  - Small values are set for the filters
    - Fast response time
    - Possibly unstable measured value
- **Standard solid**
  - For bulk solids applications that do not suit any of the options
  - Average filter values and output damping
- **Solid dusty**
  - For dusty bulk solids
  - The filters are set in such a way that even relatively weak wanted signals are detected
- **Conveyor belt**
  - For bulk solids with rapid changes in the level, e.g. conveyor belts
  - Low values are set for the filters.
    - Fast response time, possibly unstable measured value
- **Test: no filter**
  - For service and diagnostics only
  - All the filters are switched off.

## Empty calibration and full calibration

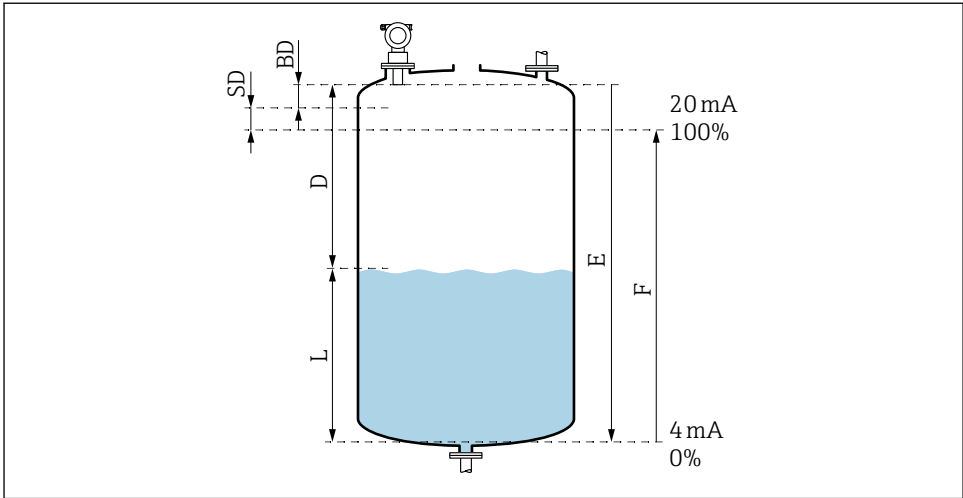

A0038386

### 12 Parameters for the correct operation of the device

- D* Distance (sensor membrane/product)
- E* Empty calibration = zero point
- F* Full calibration = measuring span
- L* Level
- BD* Blocking distance
- SD* Safety distance

### Empty calibration function (005)

Specify the distance *E* from the sensor membrane = reference point of the measurement to the minimum level (zero point).

**i** Torispherical head or conical outlets: the zero point should not be lower than the point where the ultrasonic wave hits the bottom of the tank.

### Blocking distance function (059)

The blocking distance (*BD*) of the sensor is displayed.

After the basic setup, enter the safety distance (*SD*) in the **Safety distance (015)** function

**i** When entering the full distance, make sure that the maximum level does not enter the blocking distance.



**NOTICE**

**If the blocking distance is undershot, this may cause a device malfunction.**

- ▶ Mount the measuring device high enough that the blocking distance is not reached at the maximum fill level.
- ▶ Define the safety distance (SD).
- ▶ If the level enters the safety distance SD, the device generates a warning or alarm.
- ▶ The measuring span F may not project into the blocking distance BD. Level echoes within the blocking distance cannot be evaluated due to the transient response of the sensor.

*Full calibration function (006)*

Specify the measuring span F (distance from the minimum to the maximum level).

**Interference echo suppression (mapping)**

*Dist./meas.value function (008)*

This function displays the measured distance D from the sensor membrane to the surface of the product together with the level L. Check whether the values displayed match the actual distance/level.

*"Check distance" function (051)*

Start the mapping process.

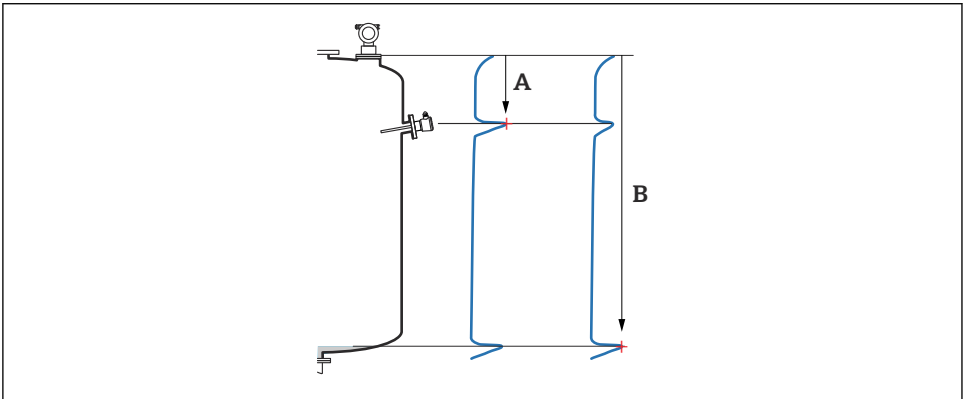

A0038449

13 Example of mapping

A Distance too small

B Distance = Ok

### Selection and description

- **Distance = ok** → the correct distance is displayed  
Any echoes closer to the sensor will be suppressed by the subsequent interference echo suppression (mapping).
- **Dist. too small** → the displayed distance is too small  
In this case, the signal comes from an interference echo and will be suppressed by the subsequent interference echo suppression.
- **Dist. too big** → the displayed distance is too big
  - The error cannot be rectified by suppressing the interference echo. Two functions that follow are then skipped.
  - Check the application parameters: **Tank shape (002)**, **Medium properties (003)**, **Process cond. (004)** and in the function group **Basic setup (00)** → **Empty calibration (005)**
- **Dist. unknown** → the actual distance is not known  
Two functions that follow are then skipped.
- **Manual** → you can specify the mapping range yourself in the following function

### *Range of mapping (052) function*

- The range of mapping is displayed, confirm the proposed value or enter your own value
- The sensor membrane is always the reference point
- The value can be edited by the user
- For manual suppression (mapping), the default value is 0 m



The mapping range must end 0.5 m (1.6 ft) before the echo of the actual level. If the tank is empty enter E - 0.5 m instead of E.

### *Start mapping (053) function*

#### Selection

- Off: no mapping
- On: mapping starts



If a mapping already exists, it will be overwritten up to the distance specified. The existing mapping remains unchanged beyond this distance.

### *Dist./meas.value function (008)*

#### Information displayed after mapping

Distance measured from the sensor membrane to the product surface

Check whether the values displayed match the actual distance or actual level.

The following situations can occur:

- Distance and level correct: **Basic setup** completed
- Distance and level incorrect: perform another mapping in the **Check distance (051)** function
- Distance is correct but the level is incorrect: check the value in the **Empty calibration (005)** function

### *Return to group selection*



After the mapping has been recorded the basic setup is finished and the device automatically returns to the group selection.





71571002

[www.addresses.endress.com](http://www.addresses.endress.com)

---