

Technical Information

TOC Analyzer CA79

Determination of total organic carbon (TOC) in the trace range



Powerful compact device

Application

The analyzer is designed to determine the total organic carbon in ultrapure water applications that meet the following conditions:

- Conductivity < 2 $\mu\text{S}/\text{cm}$
- pH range: neutral

Your benefits

- Fast commissioning due to short run-in period
- Compact design for flexible installation
- Low limit of detection and short response time
- Compliance with leading pharmacopoeia
- Minimum training required thanks to intuitive user interface

Table of contents

Function and system design	3	Sample outlet	7
Measuring principle	3	Sample quality	7
Device architecture	3	Maximum conductivity of sample	7
Function diagram	3	Sample supply	7
Reliability	4	Mechanical construction	8
Maintainability	4	Dimensions	8
Data security	4	Weight	8
Input	4	Materials	8
Measured variables	4	Hose specification	8
Measuring range	4	Operability	8
Input signal	4	Operating concept	8
Output	4	Display	8
Output signal	4	Operating language	8
Load	4	Certificates and approvals	8
Transmission behavior	4	Ordering information	9
Current outputs, active	4	Product page	9
Span	4	Product Configurator	9
Power supply	4	Scope of delivery	9
Supply voltage	4	Accessories	9
Power consumption	4		
Power supply cable	4		
Performance characteristics	5		
Measured variable	5		
Limit of detection (LOD)	5		
Response time t90	5		
Number of measuring channels	5		
Sample requirement	5		
UV reactor	5		
Calibration interval	5		
Maintenance intervals	5		
Maintenance effort	5		
Installation	5		
Mounting location	5		
Installation instructions	5		
Environment	6		
Ambient temperature range	6		
Storage temperature	6		
Relative humidity	6		
Degree of protection	6		
Electromagnetic compatibility	7		
Electrical safety	7		
Pollution degree	7		
Process	7		
Sample temperature	7		
Process pressure	7		

Function and system design

Measuring principle

Determination of total organic carbon (TOC) in the life science industry

In ultrapure water systems in the life science industry, any biological activity must be reliably prevented. This also applies for hard-to-access areas of ultrapure water preparation and storage. In online analytics, TOC is the established sum parameter for this measurement task. Water that is virtually TOC-free does not offer microorganisms an environment for growth. In addition, any microorganisms introduced from the outside are detected immediately due to the carbon they contain. Extremely low TOC values therefore offer double protection against biological contamination of ultrapure water facilities. TOC measurement has therefore become the established method at numerous measuring points in the ultrapure water system. Accompanying processes, such as the generation of ultrapure steam or the operation of cage washers, are also regularly monitored by online TOC analysis.

TOC determination based on UV digestion and the measurement of differential conductivity

The TOC analyzer uses the fast and reliable digestion of organic substances by short-wave UV radiation. The organic substances are oxidized to CO_2 during the time the medium is in contact with the UV light. Via the carbonic acid balance, the dissolved CO_2 then causes the conductivity to increase due to the formation of hydrogen carbonate. A pair of electrodes located upstream and downstream from the UV radiation measures the increase in conductivity and converts it to TOC. Due to the very low limit of detection, the method applied in the analyzer has become the established standard worldwide for applications in the life science industry.

Device architecture

Function diagram

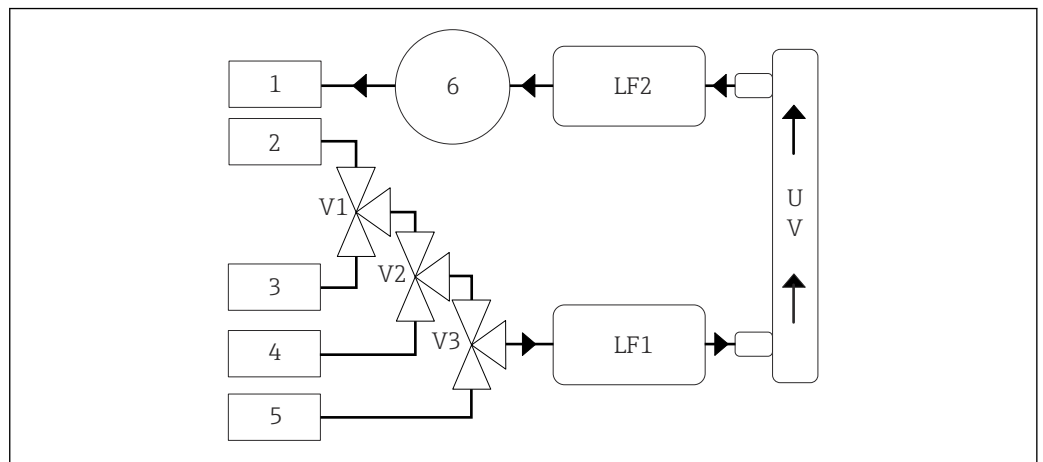

1 Process diagram

1 Waste

2 Sample

3 Input 1

4 Input 2

5 Input 3

6 Pump

V1 - Valve 1, valve 2 (order option) and valve 3 (order option)

V3

LF1 - Conductivity and temperature sensors

LF2

UV UV lamp (12 VDC)

A0046935

Reliability

Maintainability	The device has defined maintenance intervals for all wear parts. When the maintenance schedule is followed, the device therefore offers an extremely high degree of reliability and enables high measuring point availability.
Data security	The analyzer has been developed with a software that meets the requirements of 21 CFR, Section 11. It is therefore optimized for use in the life science industry.

Input

Measured variables	TOC
Measuring range	0.5 to 1 000 µg/l (ppb)
Input signal	Controller input 24 V (order option) The controller input starts a measurement. The function is only available for 1-channel devices.

Output

Output signal	Measuring channel 1 0/4 to 20 mA, galvanically isolated Measuring channel 2 (optional) 0/4 to 20 mA, galvanically isolated
Load	Max. 500 Ω
Transmission behavior	Configurable, in the measuring range of 4 to 20 mA Standby: 3.8 mA

Current outputs, active

Span	0 to 20 mA; according to Namur NE43
-------------	-------------------------------------

Power supply

Supply voltage	100/240 V AC, 47 - 63 Hz
Power consumption	Max. 60 W
Power supply cable	2 m, Type E+F mains plug pre-installed

Performance characteristics

Measured variable ¹⁾	TOC (total organic carbon)
Limit of detection (LOD)	0.1 µg/l (ppb)
Response time t90	50 s
Number of measuring channels	1 to 3, depending on the order version
Sample requirement	~ 14 ml/min.
UV reactor	UV reactor with continuous function monitoring
Calibration interval	The device is calibrated on delivery. It is recommended to perform a new calibration after replacing components in contact with the process, such as the pump hose or UV reactor.
Maintenance intervals	<ul style="list-style-type: none">■ Replacement of calibration solution - before every calibration■ Replacement of pump hose - every 6 months■ Replacement of UV reactor - every 6 months■ Replacement of UV reactor ballast - every 24 - 36 months■ Replacement of pump head - every 36 - 48 months
Maintenance effort	1 hour per month

Installation

Mounting location	Bench-top or wall mounting
Installation instructions	Place the analyzer on an even, vibration-free surface. The four blind rivet nuts (M6) on the back of the housing can be used to mount the analyzer on the wall.

1) +/- 0.5 µg/l (ppb) or 1 %, the larger value applies in each case

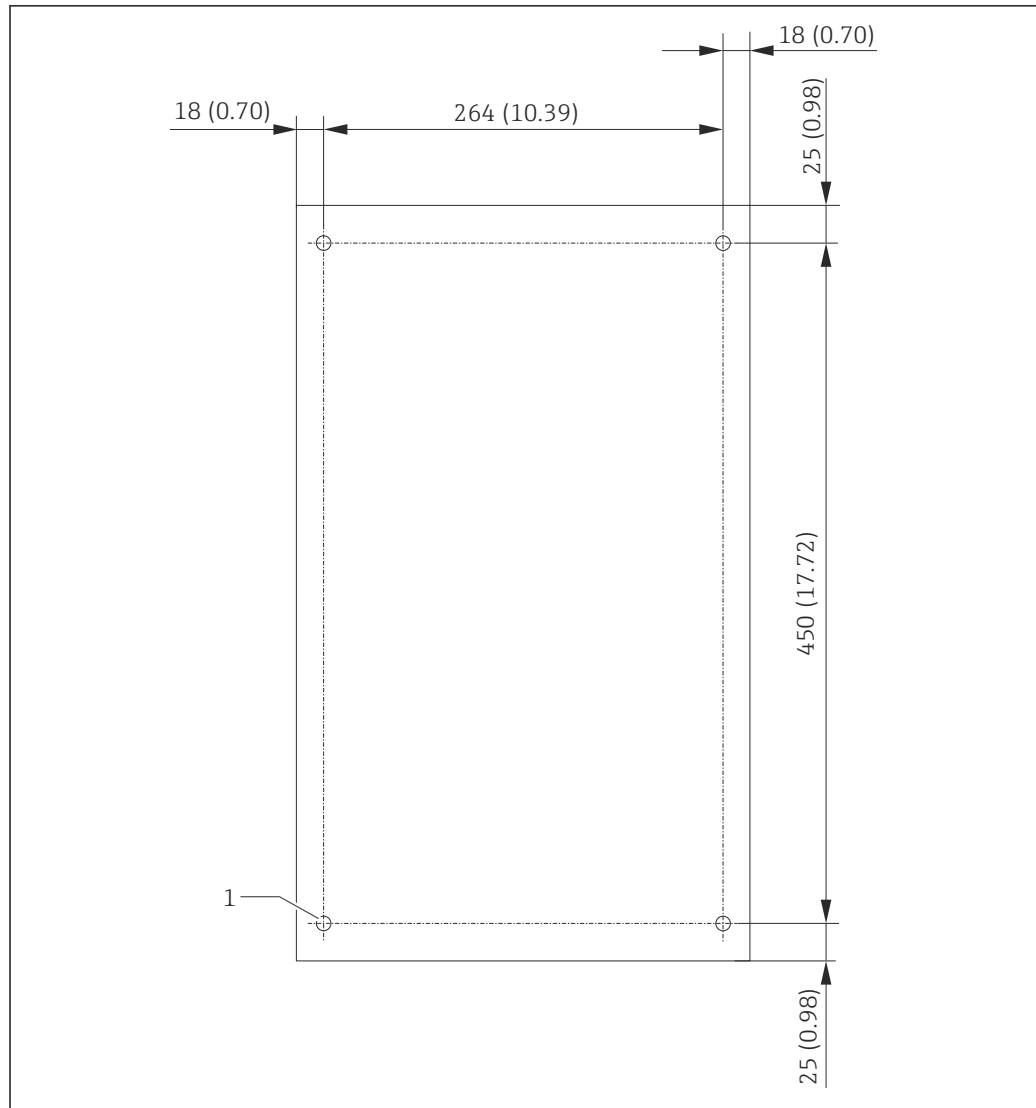

2 Rear of the housing

1 Blind rivet nut

The mounting location must be free from vibrations and the wall must have sufficient load-bearing strength.

Environment

Ambient temperature range	10 to 45 °C (50 to 113 °F)
Storage temperature	2 to 55 °C (35 to 131 °F)
Relative humidity	10 to 90 %, non-condensating
Degree of protection	IP 42 (standard device), IP54 (order option)

Electromagnetic compatibility²⁾	Interference emission and interference immunity as per EN 61326-1:2013, Class A for Industry
---	--

Electrical safety	According to EN/IEC 61010-1:2010, Class 1 equipment Low voltage: overvoltage category II For installations up to 3 000 m (9 800 ft) above MSL
--------------------------	---

Pollution degree	2
-------------------------	---

Process

Sample temperature	< 50 °C (122 °F)
---------------------------	------------------

Process pressure	Max. 0.5 bar (7.25 psi); recommended 0.25 bar (3.62 psi)
-------------------------	--

Sample outlet	Depressurized
----------------------	---------------

Sample quality	Particle-free
-----------------------	---------------

Maximum conductivity of sample	2 µS/cm
---------------------------------------	---------

Sample supply	<ul style="list-style-type: none"> ▪ 1 port for sample: 1 port for system suitability test, manual ▪ Order option 1: 1 port for sample, 3 ports for system suitability test, automated ▪ Order option 2: 3 ports for sample, 1 port for system suitability test, manual
----------------------	--

2) Sufficient mains quality is required to operate the product as designated.

Mechanical construction

Dimensions

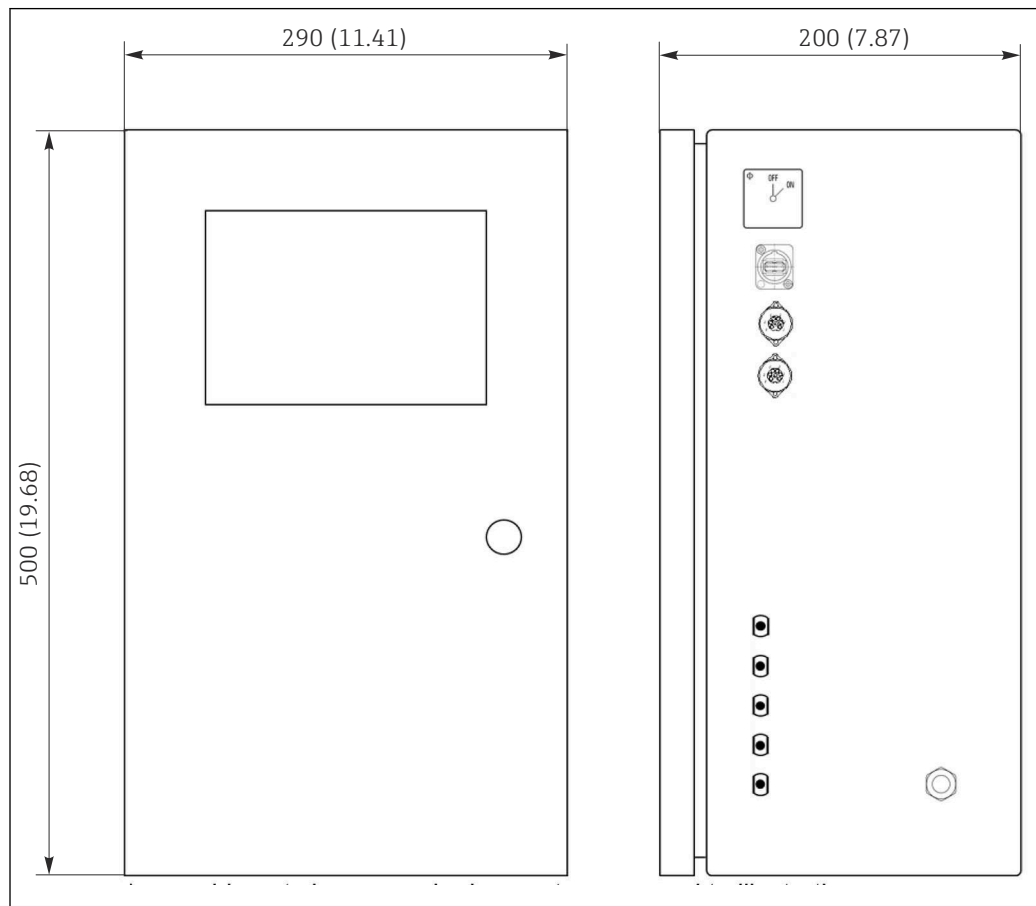

A0046932

3 Dimensions in mm (in)

Weight	Approx. 14 kg (30.86 lb)
Materials	Stainless steel housing
Hose specification	Sample hose 1/8 inch, 3.2 mm OD included in connection kit

Operability

Operating concept	The operating concept and data storage meet the requirements of 21 CFR, Part 11.
Display	8" touch screen monitor
Operating language	English (US)

Certificates and approvals

Current certificates and approvals that are available for the product can be selected via the Product Configurator at www.endress.com:

1. Select the product using the filters and search field.
2. Open the product page.

3. Select **Configuration**.

Ordering information

Product page www.endress.com/ca79

Product Configurator

1. **Configure**: Click this button on the product page.
 2. Select **Extended selection**.
 - ↳ The Configurator opens in a separate window.
 3. Configure the device according to your requirements by selecting the desired option for each feature.
 - ↳ In this way, you receive a valid and complete order code for the device.
 4. **Apply**: Add the configured product to the shopping cart.
-  For many products, you also have the option of downloading CAD or 2D drawings of the selected product version.
5. **Show details**: Open this tab for the product in the shopping cart.
 - ↳ The link to the CAD drawing is displayed. If selected, the 3D display format is displayed along with the option to download various formats.

Scope of delivery

The scope of delivery comprises:

- 1 analyzer with the configuration ordered
- 1 installation kit
- 1 certificate of calibration
- 1 certificate of the system suitability test (SST)
- 1 x Operating Instructions

Accessories

The following are the most important accessories available at the time this documentation was issued.

- ▶ For accessories not listed here, please contact your Service or Sales Center.

CA78/79 pressure reducer kit

Supply pressure: max. 10 bar (145 psi), adjustable output pressure

Order No. 71543593

CA78/79 heat exchanger kit

Temperature: can be used up to a maximum temperature of 90 °C (194 °F)

Order No. 71543592



www.addresses.endress.com
