

Installation Instructions

Device replacement of the "Sensor, remote" version

Levelflex



1 Intended use

- A defective unit can only be replaced with a functioning unit of the same type.
- Use only original parts from Endress+Hauser.
- Check in the W@M Device Viewer if the spare part is suitable for the existing measuring device.

 In some measuring devices, an overview of spare parts is provided inside the device. If the spare part set is listed in the overview, it is not necessary to check the Device Viewer.

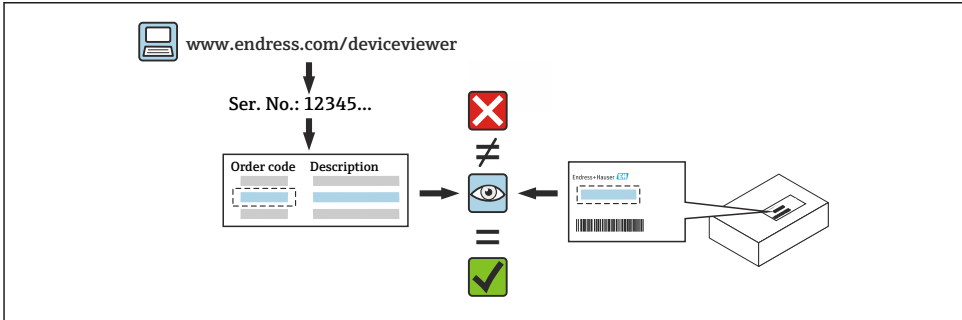

2 Personnel authorized to carry out repairs

Technical staff must comply with the following requirements for repair, mounting, electrical installation and commissioning of the measuring devices:

- Specialized technical staff must be trained in instrument safety.
- They must be familiar with the individual operating conditions of the devices.
- In the case of Ex-certified measuring devices, they must also be trained in explosion protection.

 Technical staff carrying out work are responsible for ensuring that the work is carried out safely and to the required quality standard. They must also guarantee the safety of the device following repair.





3 Safety instructions

- Comply with national regulations governing mounting, electrical installation, commissioning, maintenance and repair procedures.
- Device is live! Risk of fatal injury from electric shock. Open the device only when the device is deenergized.
- For devices intended for use in hazardous locations, please observe the instructions in the Ex documentation (XA).

- In the case of devices in safety-related applications in accordance with IEC 61508 or IEC 61511: Commission in accordance with Operating Instructions after repair. Document the repair procedure.
- Before removing the device: set the process to a safe state and purge the pipe of dangerous process substances.
- Danger of burns due to heated surfaces! Before commencing work: allow the system and device to cool down to a touchable temperature.
- In the case of devices in custody transfer, the custody transfer status no longer applies once the seal has been removed.
- Observe the Operating Instructions for the device.
- Risk of damaging the electronic components! Ensure you have a working environment protected from electrostatic discharge.
- After removing the electronics compartment cover: risk of electrical shock due to missing touch protection!
Switch the device off before removing internal covers.
- Modifications to the device are not permitted.
- Only open the housing for a brief period. Avoid the penetration of foreign bodies, moisture or contaminants.
- Replace defective seals only with original seals from Endress+Hauser.
- If threads are damaged or defective, the device must be repaired.
- Do not lubricate threads (e.g. of electronics compartment cover or connection compartment cover).
- If spacing is reduced or the dielectric strength of the device is not guaranteed during repair work, perform a test on completion of the work (e.g. high-voltage test in accordance with the manufacturer's instructions).
- Service plug:
 - Do not connect in explosive atmospheres.
 - Only connect to Endress+Hauser service devices.
- Observe the instructions for transporting and returning the device outlined in the Operating Instructions.

 Contact Endress+Hauser Service if you have questions: www.addresses.endress.com

4 Tools list

 <p>3 mm 5 mm</p>	 <p>≤3 mm</p>	 <p>T10 mm</p>	 <p>18 mm</p>
--	--	---	--

5 Replacing housing GT18, GT19 or GT20

i Carefully remove the cover and modules and store them in a safe place until they are installed in the new housing.

5.1 Removing the I/O module

Optional: cover lock

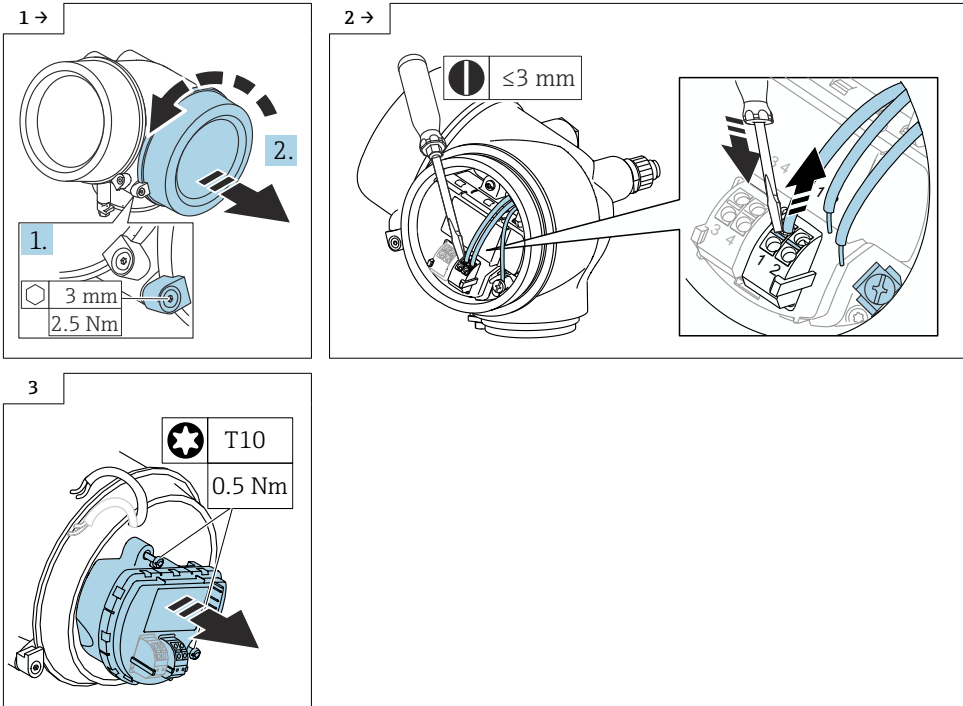

5.2 Removing the electronics module

Optional: cover lock, display

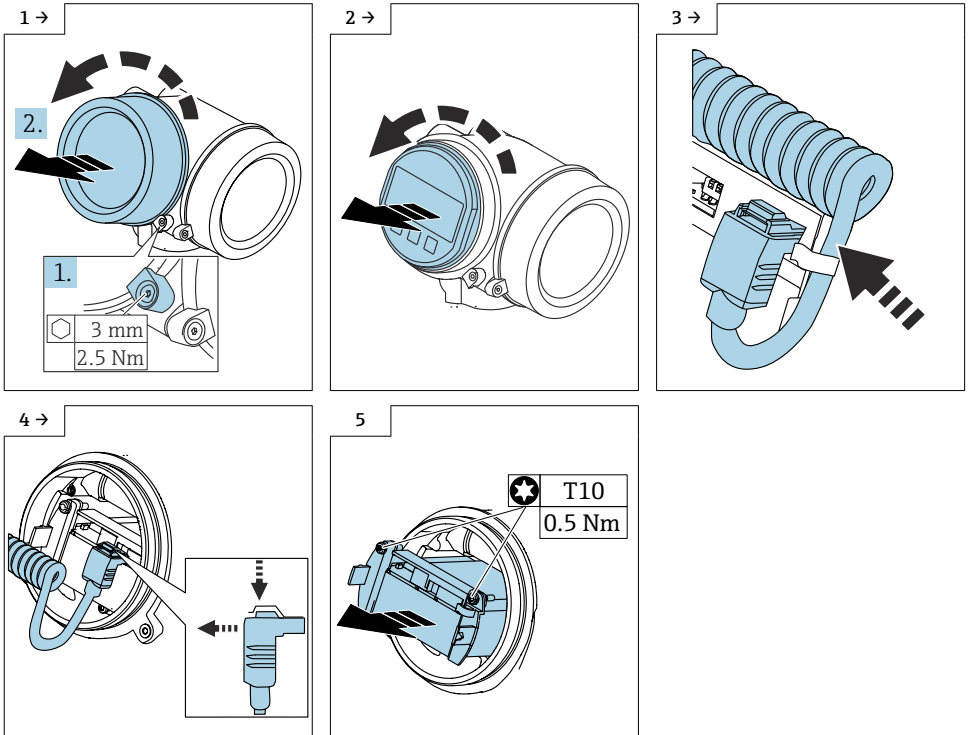

5.3 Disassembling the housing

i Protect the probe/antenna against mechanical damage.

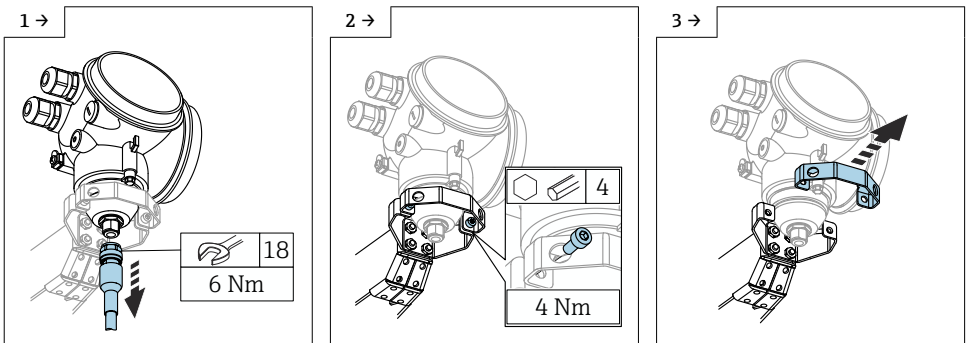

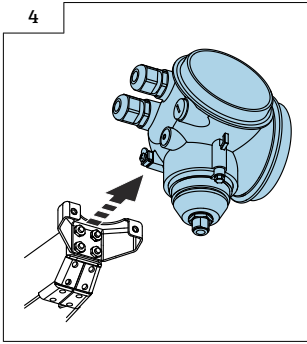

5.4 Installing the electronics and the I/O module

Installation is performed by following the removal procedure in reverse order.

Once fully assembled, the device is ready for operation again.

6 Disposal



If required by the Directive 2012/19/EU on waste electrical and electronic equipment (WEEE), the product is marked with the depicted symbol in order to minimize the disposal of WEEE as unsorted municipal waste. Do not dispose of products bearing this marking as unsorted municipal waste. Instead, return them to the manufacturer for disposal under the applicable conditions.



71588332

www.addresses.endress.com
