



Brief Operating Instructions Liquiphant FTL33

Point level switch for liquids in the food industry

These Brief Operating Instructions are not a substitute for the Operating Instructions pertaining to the device.

Detailed information is provided in the Operating Instructions and other documentation.

Available for all device versions via:

- Internet: www.endress.com/deviceviewer
- Smartphone/tablet: Endress+Hauser Operations app

Basic safety instructions

Requirements for the personnel

The personnel performing installation, commissioning, diagnostics and maintenance must satisfy the following requirements:

- Trained, qualified specialists: must have a relevant qualification for this specific function and task
- Are authorized by the plant owner/operator
- Are familiar with federal/national regulations
- Before starting work: read and understand the instructions in the manual and supplementary documentation as well as the certificates (depending on the application)
- Follow instructions and comply with basic conditions

Intended use

The device described in this manual may be used only as a point level switch for liquids. The device is suitable for use in areas with strict hygiene requirements. Incorrect use of the device may pose a hazard.

To ensure that the device remains in proper condition for the operation time:

- Use the device only for media to which the wetted materials have an adequate level of resistance
- Comply with the limit values, see the "Technical data" section of the Operating Instructions

Operational safety

Danger of injury!

- Operate the device only if it is in proper technical condition, free from errors and faults.
- The operator is responsible for the interference-free operation of the device.

Mounting



The mounting process is illustrated in the following section on the basis of sample configurations. For detailed information, see the Operating Instructions.

Mounting requirements

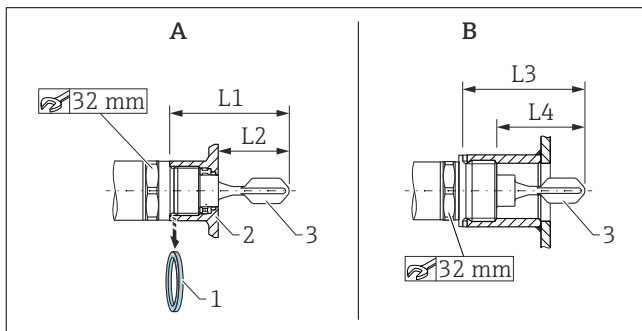

A Device with weld-in adapter

B Device in customer socket

1 Flat seal

2 Weld-in adapter

3 Tuning fork

L1 With G 1" thread: 66,4 mm (2,61 in) / With G 3/4" thread: 63,9 mm (2,52 in)

L2 With G 1" thread: 48,0 mm (1,89 in) / With G 3/4" thread: 38,0 mm (1,5 in)

L3 With G 1" thread: 66,4 mm (2,61 in)

L4 With G 1" thread: 47,9 mm (1,8 in)

Installation is possible in any position in a vessel, pipe or tank under the following conditions:

- When installed horizontally in a vessel, the tuning fork may be located in an installation socket only if liquids with low viscosity (< 2 000 mPa·s) are used.
- Minimum diameter of installation socket: 50 mm (2.0 in)
- Select a maximum length for the installation socket that enables the tuning fork to project freely into the vessel.
- Ensure that there is sufficient distance between the expected buildup on the tank wall and the fork. Recommended distance from wall ≥ 10 mm (0.39 in).

Important process conditions

Pressure and temperature (maximum):

- With weld-in adapter
 - +25 bar (+362 psi) at +150 °C (+302 °F)
 - +40 bar (+580 psi) at +100 °C (+212 °F)
- In customer socket
 - +40 bar (+580 psi) at +150 °C (+302 °F)

Operating altitude:

Up to 2 000 m (6 600 ft) above sea level



In the case of seals used at the customer site, pay attention to the temperature and pressure specifications.

Mounting the device

An open-ended wrench (32 mm) is required for mounting.

- i** For the NTP thread (ANSI B 1.20.1): use sealing material (PTFE) if necessary.
- i** For the weld-in adapter with a flush-mount seal: remove the supplied flat seal (1) from the thread.
- i** For the weld-in adapter with leakage hole: make sure the leakage hole points downwards.

Aligning the tuning fork

- i** The markings for the material specification (e.g. 316L) or the thread designation (e.g. G 3/4") on the device are aligned with the opening of the tuning fork and therefore aid orientation.

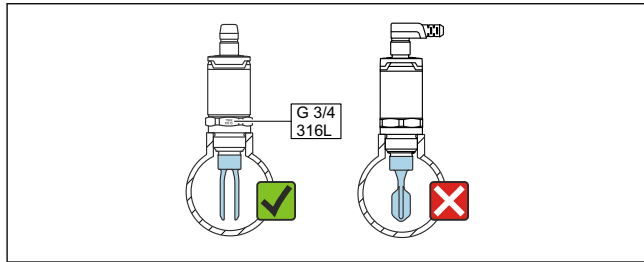

- 1** In the pipe: align the opening of the tuning fork parallel to the flow direction in such a way that the liquid can flow unhindered between the two tuning fork elements.

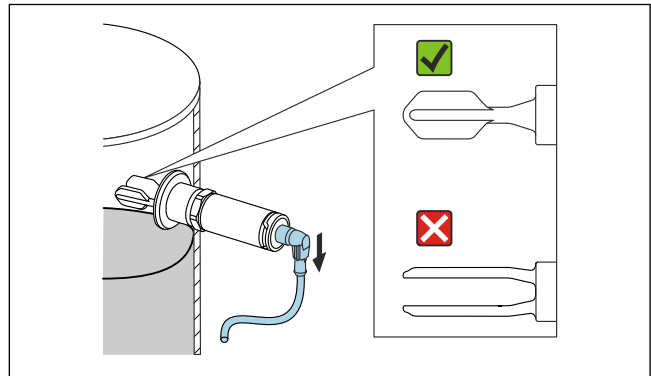

- 2** For horizontal installation in a vessel: align the tuning fork in such a way that both tuning fork elements are simultaneously covered with liquid.
- Fix the device with a maximum torque of 30 Nm (22 lbf ft). Also pay attention to the alignment of the tuning fork when doing so.

Electrical connection

The connection with the M12 plug is presented in the following section. For other connection options, see the Operating Instructions.

- i** In accordance with IEC/EN61010 a suitable circuit breaker must be provided for the device.

Power supply

Electronic version	Supply voltage	Power consumption	Current consumption
3-wire DC-PNP	10 to 30 V DC	< 975 mW	< 15 mA
2-wire AC/DC	20 to 253 V	< 850 mW	< 3.8 mA

Reverse polarity protection	2-wire AC/DC
	<ul style="list-style-type: none"> ▪ AC mode: the device has reverse polarity protection. ▪ DC mode: in the event of reverse polarity the maximum safety mode is always detected. Check the wiring and perform a function check before commissioning. The device is not damaged in the event of reverse polarity.
	3-wire DC-PNP
	Integrated. In the event of reverse polarity, the device is deactivated automatically.

Connection with M12 plug

Maximum safety		
Terminal assignment	MAX output	Yellow LED

Minimum safety		
Terminal assignment	MIN output	Yellow LED

LED indicator

- 1 LED is green: the device is operational
- 2 LED is yellow: tuning fork is covered by liquid
- 3 LED is red: warning/maintenance required (LED flashing) or fault/device failure (LED is lit)

- i** On the metal housing cover (IP69), there is no external signaling via LEDs.