

# Safety Instructions

## J22 TDLAS Gas Analyzer

JPNEx IECEx: Zone 1

Safety instructions for the J22 TDLAS gas analyzer in explosion-hazardous areas





# Table of Contents

- 1 Introduction..... 4**
  - 1.1 Intended Equipment Use ..... 4
  - 1.2 Associated Documentation..... 4
  - 1.3 Manufacturer’s Certificates..... 4
  - 1.4 Manufacturer Address ..... 6
  
- 2 General Safety ..... 7**
  - 2.1 Warnings ..... 7
  - 2.2 Symbols ..... 7
  - 2.3 U.S. Export Compliance..... 8
  - 2.4 Labels ..... 8
  - 2.5 Personnel Qualifications ..... 9
  - 2.6 Equipment Training ..... 10
  - 2.7 Potential Risks Affecting Personnel ..... 10
  - 2.8 Analyzer Technical Specifications..... 11
  
- 3 Installation ..... 14**
  - 3.1 Lifting/Carrying the Analyzer ..... 14
  - 3.2 Mounting the Analyzer..... 14
  - 3.3 Opening/Closing the Analyzer Enclosure ..... 17
  - 3.4 Protective Chassis and Ground Connections ..... 17
  - 3.5 Electrical Wiring Requirements ..... 19
  - 3.6 IS Flow Switch Connection Requirements ..... 21
  - 3.7 Connection Values: Signal Circuits..... 22
  - 3.8 Electrical Circuit Breakers..... 23
  - 3.9 Connecting the Gas Supply ..... 23
  - 3.10 Sample System Heater ..... 23
  
- 4 Equipment Operation ..... 24**
  - 4.1 Operating Controls ..... 24
  - 4.2 Commissioning ..... 24
  - 4.3 Decommissioning ..... 24
  
- 5 Maintenance and Service ..... 26**
  - 5.1 Cleaning and Decontamination..... 26
  - 5.2 Troubleshooting and Repairs ..... 26
  - 5.3 Spare Parts ..... 31
  - 5.4 Service ..... 31

# 1 Introduction

Endress+Hauser's J22 TDLAS Gas Analyzer is a laser-based extractive analyzer for measuring gas concentration. The technology employed is Tunable Diode Laser Absorption Spectroscopy (TDLAS). Typical measurement ranges vary between 0 to 10 parts-per-million by volume (ppmv) and 0 to 100% by volume.

## 1.1 Intended Equipment Use

The J22 TDLAS Gas Analyzer is intended for use as instructed in the documentation package provided with the equipment. This information should be read and referenced by anyone installing, operating or having direct contact with the analyzer. Any use of the equipment in a manner not specified by Endress+Hauser could impair the protection provided by the equipment.

## 1.2 Associated Documentation

Each analyzer shipped from the factory is packaged with documents for the model that was purchased. All documentation is available on the USB flash drive provided with the shipment. This document is an integral part of the document package, which includes:

| Part Number | Document Type  | Description  |
|-------------|--|--|
| BA02152C    | Operating Instruction  | A complete overview of the operations required to install, commission and maintain the device.   |
| TI01607C    | Technical Information  | Provides technical data on the device with an overview of associated models available.   |
| SD02912C    | Special Documentation<br>Heartbeat<br>Verification +<br>Monitoring | Part of the Operating Instructions and serves as a reference for using the Heartbeat Technology function integrated in the measuring device. |

Table 1. Associated documentation

## 1.3 Manufacturer's Certificates

CML Certificate of Conformity

Certificate number: CML 22JPN1411X

## ATEX/IECEX Certificate of Conformity

Certificate number: CSANe 20ATEX1197X / IECEX SIR 20.0035X

## UKEX Certificate of Conformity

Certificate number: CSAE 21UKEX1072X

| <b>J22 TDLAS Gas Analyzer,<br/>           J22 TDLAS Gas Analyzer with SCS on Panel,<br/>           J22 TDLAS Gas Analyzer with Enclosed SCS,<br/>           J22 TDLAS Gas Analyzer with Enclosed SCS, with Heater</b> |  |   |
|---|--|---|
| <b>ATEX/UKEX</b>  |  | <b>IECEX</b>  |
| EN IEC 60079-0:2018<br>EN 60079-1:2014 + AC:2018-09<br>EN 60079-11:2012<br>EN 60079-28:2015   |  | IEC 60079-0:2017 Ed. 7.0<br>IEC 60079-1:2014+COR1:2018 Ed. 7<br>IEC 60079-11:2011 Ed. 6.0 |
| <b>Japanese technical recommendations</b>   | <b>Description</b>   | <b>Corresponding IEC standards</b>  |
| JNIOOSH-TR-46-1:2020  | Equipment – general requirements   | IEC 60079-0 Ed. 7 2017  |
| JNIOOSH-TR-46-2:2018  | Equipment protection by flameproof “d”                                   | IEC 60079-1 Ed. 7 2014  |
| JNIOOSH-TR-46-6:2015  | Equipment protection by intrinsic safety “I”                             | IEC 60079-11 Ed. 6 2011   |
| JNIOOSH-TR-46-11:2020   | Protection of equipment and transmission systems using optical radiation | IEC 60079-28:2015 Ed. 2   |

Table 2. Manufacturer's certificates

## **1.4 Manufacturer Address**

Endress+Hauser

11027 Arrow Route

Rancho Cucamonga, CA 91730

United States

[www.endress.com](http://www.endress.com)







## 2 General Safety

### 2.1 Warnings

| Structure of Information  | Meaning   |
|---|---|
| <p><b>⚠ WARNING</b></p> <p><b>Causes (/consequences)</b><br/>                     If necessary, consequences of non-compliance (if applicable)<br/>                     ▶ Corrective action</p> | <p>This symbol alerts you to a dangerous situation. Failure to avoid the dangerous situation can result in a fatal or serious injury.</p> |
| <p><b>⚠ CAUTION</b></p> <p><b>Causes (/consequences)</b><br/>                     If necessary, consequences of non-compliance (if applicable)<br/>                     ▶ Corrective action</p> | <p>This symbol alerts you to a dangerous situation. Failure to avoid this situation can result in minor or more serious injuries.</p>     |
| <p><b>NOTICE</b></p> <p><b>Cause/situation</b><br/>                     If necessary, consequences of non-compliance (if applicable)<br/>                     ▶ Action/note</p>                 | <p>This symbol alerts you to situations which may result in damage to property.</p>   |

Table 3. Warnings

### 2.2 Symbols

| Symbol  | Description  |
|---|--|
|   | The Laser Radiation symbol is used to alert the user to the danger of exposure to hazardous visible laser radiation when using the system. The laser is a class 3R radiation product.  |
|  | The High Voltage symbol that alerts people to the presence of electric potential large enough to cause injury or damage. In certain industries, high voltage refers to voltage above a certain threshold. Equipment and conductors that carry high voltage warrant special safety requirements and procedures. |
|  | Protective Earth (PE). A terminal which is bonded to conductive parts of equipment for safety purposes and is intended to be connected to an external protective earthing system.  |
|  | The Ex mark signals to Authorities Having Jurisdiction and end-users in Europe that the product complies with the essential ATEX Directive for explosion protection.   |
|  | The UKCA Marking indicates conformity with health, safety, and environmental protection standards for products sold within the United Kingdom.   |
|  | The FCC mark indicates that the electromagnetic radiation from the device is below the limits specified by the Federal Communications Commission and the manufacturer has  |

|  |  |
|--|--|
|  | followed the requirements of the Supplier's Declaration of Conformity authorization procedures.  |
|  | The CE Marking indicates conformity with health, safety, and environmental protection standards for products sold within the European Economic Area (EEA). |

Table 4. Symbols

## 2.3 U.S. Export Compliance

The policy of Endress+Hauser is strict compliance with U.S. export control laws as detailed in the website of the [Bureau of Industry and Security](#) at the U.S. Department of Commerce.

## 2.4 Labels

### 2.4.1 Nameplate

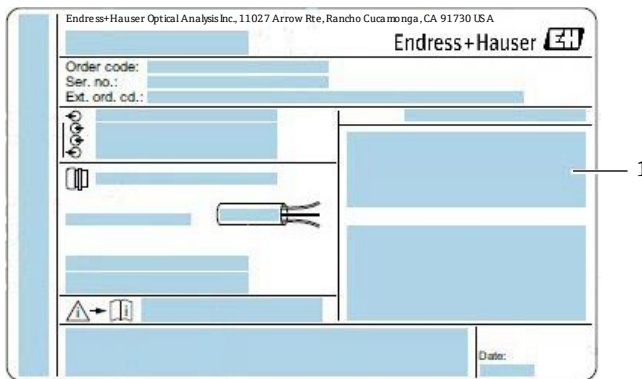
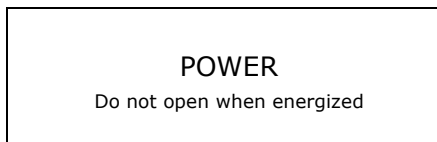

Fig 1. J22 nameplate

1 WARNING - Potential Electrostatic Discharge

### 2.4.2 Controller



Terminate power prior to accessing equipment to prevent damage to the analyzer.

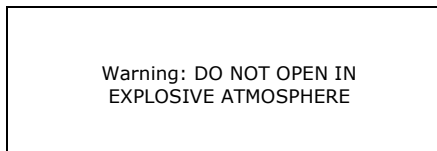

Use caution before opening the analyzer enclosure to avoid injury.



## 2.5 Personnel Qualifications

Personnel must meet the following conditions for mounting, electrical installation, commissioning and maintenance of the device. This includes, but is not limited to:

- Be suitably qualified for their role and the tasks they perform
- Be trained in explosion protection
- Be familiar with national and local regulations and guidelines
- Be familiar with lockout/tag-out procedures, toxic gas monitoring protocols and PPE (personal protective equipment) requirements

### 2.5.1 General

- Adhere to all warning labels to prevent damage to the unit.
- Do not operate the device outside the specified electrical, thermal and mechanical parameters.
- Only use the device in media to which the wetted materials have sufficient durability.
- Modifications to the device can affect the explosion protection and must be carried out by staff authorized to perform such work by Endress+Hauser.
- Only open the controller cover if the following conditions are met:
  - An explosive atmosphere is not present.
  - All device technical data is observed (see nameplate).
  - The optional stainless steel label tag is not bonded to earth. The maximum average capacitance of the tag determined by measurement is maximum 30 pF. This shall be considered by the user to determine suitability of the equipment in a specific application.
- In potentially explosive atmospheres:
  - Do not disconnect any electrical connections while the equipment is energized.
  - Do not open the connection compartment cover when energized or the area is known to be hazardous.
- Install the controller circuit wiring according to IEC 60079-14.
- Install the device according to the manufacturer's instructions and regulations.
- The flameproof joints of this equipment are other than the minimums specified in IEC/EN 60079-1 and JNIOH-TR-46-2:2018, and shall not be repaired by the user.

#### **WARNING**

**Substitution of components is not permitted.**

- ▶ Substitution of components may impair intrinsic safety.

## 2.6 Equipment Training

Refer to local service providers for installation and operational training of the J22 TDLAS Gas Analyzer.

## 2.7 Potential Risks Affecting Personnel

This section addresses the appropriate actions to undertake when faced with hazardous situations during or before service of the analyzer. It is not possible to list all potential hazards within this document. The user is responsible for identifying and mitigating any potential hazards present when servicing the analyzer.

### NOTICE

- ▶ Technicians are expected to be trained and follow all safety protocols that have been established by the customer in accordance with the area hazard classification to service or operate the analyzer. This may include, but is not limited to, toxic and flammable gas monitoring protocols, lockout/tagout procedures, the use of personal protective equipment (PPE) requirements, hot work permits and other precautions that address safety concerns related to the use and operation of process equipment located in hazardous areas.

### 2.7.1 Electrocutation hazard

1. Shut off power at the main disconnect external to the analyzer.

#### WARNING

- ▶ Complete this action before performing any service that requires working near the main input power or disconnecting any wiring or other electrical components.
2. Only use tools with a safety rating for protection against accidental contact with voltage up to 1000V (IEC 900, ASTF-F1505-04, VDE 0682/201).

### 2.7.2 Laser safety

The J22 TDLAS Gas Analyzer is a Class 1 laser product, which poses no threat to equipment operators. The laser internal to the analyzer controller is classified Class 3R and could cause eye damage if the beam is viewed directly.

#### WARNING

- ▶ Before servicing, shut off all power to the analyzer.

## 2.8 Analyzer Technical Specifications

Technical specifications are provided in the following tables that outline recommended equipment settings, ratings, and physical specifications.

| Electrical & communications     |  |  |
|---------------------------------|--|--|
| Input voltages                  | 100 to 240<br>VAC tolerance $\pm$<br>10% 50/60 Hz, 10W <sup>1</sup><br>24 VDC tolerance $\pm$ 20%, 10W<br>UM = 250 VAC<br>Heater<br>100 to 240, VAC tolerance $\pm$ 10% 50/60 Hz, 80W  |  |
| Output type                     | Modbus RS485 or Modbus TCP over Ethernet (IO1)   | $U_N = 30$ VDC<br>$U_M = 250$ VAC<br>N = nominal,<br>M = maximum                           |
|                                 | Relay Output (IO2 and/or IO3)  | $U_N = 30$ VDC<br>$U_M = 250$ VAC<br>$I_N = 100$ mA DC/500 mA AC                           |
|                                 | Configurable IO Current 4-20 mA Input/Output (Passive/Active) (IO2 and/or IO3)   | $U_N = 30$ VDC<br>$U_M = 250$ VAC  |
|                                 | Intrinsically Safe Output (Flow Switch)  | $U_o = \pm 5.88$ V<br>$I_o = 4.53$ mA<br>$P_o = 6.6$ mW<br>$C_o = 43$ mF<br>$L_o = 1.74$ H |
| Application data                |  |  |
| Environmental temperature range | Storage (analyzer and analyzer on panel):<br>-40 °C to 60 °C (-40 °F to 140 °F)<br>Storage (analyzer with enclosed Sample Conditioning System):<br>-30 °C to 60 °C (-22 °F to 140 °F)<br>Operation: -20 °C to 60 °C (-4 °F to +140 °F) |  |
| Environmental relative humidity | 80% to temperatures up to 31 °C decreasing linearly to 50% RH at 40 °C   |  |

<sup>1</sup> Transient over-voltages according to Over Voltage Category II.





|  |   |
|--|---|
| Environment: pollution degree  | Rated Type 4X and IP66 for outdoor use and considered pollution degree 2 internally   |
| Altitude   | Up to 2,000 m   |
| Sample inlet pressure (sample conditioning system)                           | 140 to 310 kPaG (20 to 45 psi)  |
| Measurement ranges (H <sub>2</sub> O)  | 0 to 500 ppmv (0 to 24 lb/mmscf)<br>0 to 2000 ppmv (0 to 95 lb/mmscf)<br>0 to 6000 ppmv (0 to 284 lb/mmscf)   |
| Sample cell operating pressure range   | Application dependent<br>800 to 1200 mbara (standard)<br>800 to 1700 mbara (optional)   |
| Sample cell tested pressure range  | -25 to 689 kPa (-7.25 to 100 psig)  |
| Sample process temperature   | -20 °C to 60 °C (-4 °F to 140 °F)   |
| Sample flow rate   | 0.5 to 1.0 slpm (1 to 2 scfh)   |
| Bypass flow rate   | 0.5 to 1.0 slpm (1 to 2 scfh)   |
| <b>Area classification</b>   |   |
| J22 TDLAS gas analyzer   | <u>ATEX/IECEX/UKEX</u> :  II 2G<br>Ex db ia [ia Ga] ib op is IIC T4 Gb<br>Tambient = -20 °C to 60 °C |
| J22 TDLAS gas analyzer with sample conditioning system on panel              | <u>ATEX/IECEX/UKEX</u> :  II 2G<br>Ex db ia ib op is IIC T4 Gb<br>Tambient = -20 °C to 60 °C       |
| J22 TDLAS gas analyzer with enclosed sample conditioning system              | <u>ATEX/IECEX/UKEX</u> :  II 2G<br>Ex db ia ib op is IIC T4 Gb<br>Tambient = -20 °C to 60 °C       |
| J22 TDLAS gas analyzer with enclosed sample conditioning system, with heater | <u>ATEX/IECEX/UKEX</u> :  II 2G<br>Ex db ia ib op is IIC T3 Gb<br>Tambient = -20 °C to 60 °C       |
| Ingress protection   | Type 4X, IP66   |

Table 5. Analyzer Technical Specifications

### **2.8.1 Electrostatic discharge**

The coating and the adhesive label is non-conducting and may generate an ignition capable level of electrostatic discharge under certain extreme conditions. The user should ensure that the equipment is not installed in a location where it may be subjected to external conditions, such as high pressure steam, which may cause a build-up of electrostatic charges on non-conducting surfaces. To clean the equipment, use only a damp cloth.

### **2.8.2 Chemical compatibility**

Never use vinyl acetate or acetone or other organic solvents to clean the analyzer housing or labels.

## 3 Installation

### CAUTION

**The safety of the analyzer is the responsibility of the installer and the organization they represent.**

- ▶ Use appropriate protective safety equipment as recommended by local safety codes and practices (e.g., hard hat, steel-toe shoes, gloves, etc.) and exercise caution particularly when installing equipment at a height (i.e., one (1) meter above ground).

### 3.1 Lifting/Carrying the Analyzer

The analyzer should be lifted and/or moved by a minimum of two individuals.

Never lift the analyzer by the controller enclosure or conduit runs, cable glands, cables, tubing or any other part protruding through the enclosure wall or edge of the panel or enclosure. Always carry the load using the following points/method shown under Mounting the Analyzer.

### 3.2 Mounting the Analyzer

Mounting the J22 is based on the style of analyzer. When ordered without a sample conditioning system, the J22 may be specified with an optional mounting plate for installation. When specified with a sample conditioning system the analyzer may be wall or post-mounted.

When mounting the analyzer, be sure to position the instrument so that it is not difficult to operate adjacent devices. Refer to the layout diagrams mounting dimensions and additional instructions in the Operator's Manual.

#### 3.2.1 Wall Mounting

##### Tools and hardware

- Mounting hardware
- Spring nuts
- Machine screws and nuts to fit the size of the mounting hole

### NOTICE

**The J22 analyzer is designed for operation within the specified ambient temperature range. Intense sun exposure in some areas may impact the temperature inside the analyzer controller.**

- ▶ Installing a sunshade or canopy over the analyzer for outdoor installations in cases where the rated temperature range could be exceeded is recommended.

- ▶ Hardware used for mounting the J22 TDLAS Gas Analyzer must be able to support four times the weight of the instrument (approximately 16 kg (36 lbs) to 43 kg (95 lbs) depending on configuration).

**To install the J22 on a wall**

1. Install the bottom two mounting bolts to the mounting frame or wall. Do not fully tighten the bolts. Leave approximately a 10 mm (1/4 in.) gap to slide the analyzer mounting tabs onto the bottom bolts.
2. Lift the analyzer vertically at the points shown in the figure below.

**⚠ CAUTION**

- ▶ Distribute the weight evenly among personnel to avoid injury.

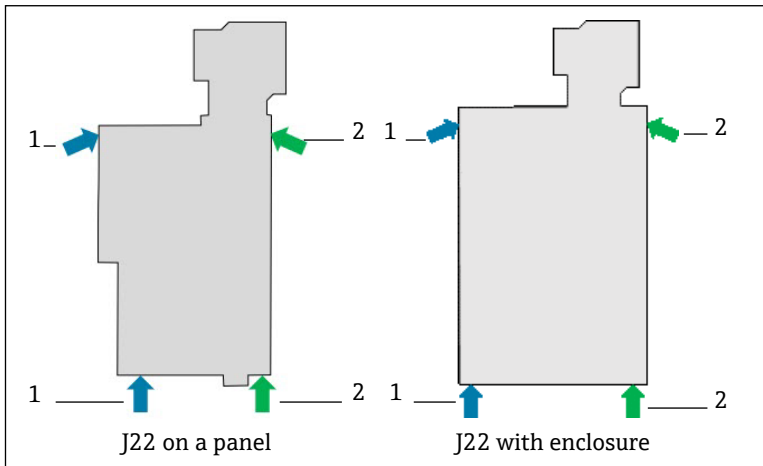

Fig 2. J22 wall mounting lifting points

- 1 Person one hand positions
- 2 Person two hand positions

3. Lift the analyzer onto the bottom bolts and slide the slotted bottom mounting tabs over the bolts. Allow the two bottom bolts to take the weight of the analyzer while stabilizing in a vertical orientation.

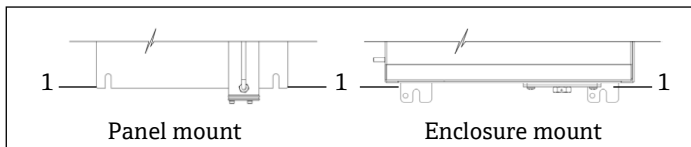

Fig 3. J22 slotted tab locations

- 1 Slotted tabs

4. Tilt the analyzer and push it towards the mounting frame or wall while aligning the two top bolts.
5. While one person exerts the necessary pressure to hold the analyzer to the frame or wall, the second person secures the two top bolts.
6. Tighten all four bolts.

### 3.2.2 Plate mounting

The plate mounting option is designed for users who will install the J22 analyzer within their own enclosure. The J22 should be installed vertically with the analyzer controller exposed to the exterior of the enclosure.

#### Tools and hardware

- Mounting hardware (supplied with plate)
- Gasket (supplied with plate)

#### To install the J22 on a plate

1. Refer to mounting plate dimensions in the *J22 TDLAS Gas Analyzer Operating Instructions* to provide a proper cut-out in the user-supplied enclosure. See [Associated Documentation](#) → .
2. Lower analyzer through the enclosure hole so the plate aligns with the gasket.
3. Secure analyzer in place with eight M6 x 1.0 screws and corresponding nuts. Tighten to a minimum 13 N-m (115 lb-in).

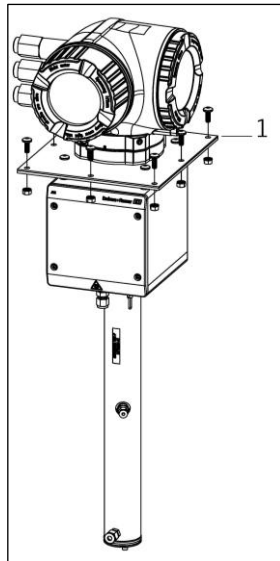

Fig 4. J22 plate mounting bracket and hardware  
1 Plate mounting bracket and hardware



### 3.3 Opening/Closing the Analyzer Enclosure



#### **Hazardous voltage and risk of electric shock.**

- ▶ Failure to properly ground the analyzer may create a high-voltage shock hazard.

### 3.4 Protective Chassis and Ground Connections

Before connecting any electrical signal or power, the protective and chassis grounds must be connected.

- Protective and chassis grounds must be of equal or greater size than any other current-carrying conductors, including the heater located in the sample conditioning system
- Protective and chassis grounds to remain connected until all other wiring is removed
- Protective grounding wire current carrying capacity must be at minimum the same as the main supply
- Earth bonding/chassis ground shall be at least 6 mm<sup>2</sup> (10 AWG)

#### 3.4.1 Protective ground cable

- Analyzer: 2.1 mm<sup>2</sup> (14 AWG)
- Enclosure: 6 mm<sup>2</sup> (10 AWG)

The grounding impedance must be less than 1 Ω.

### 3.4.2 Ground connections

#### Analyzer

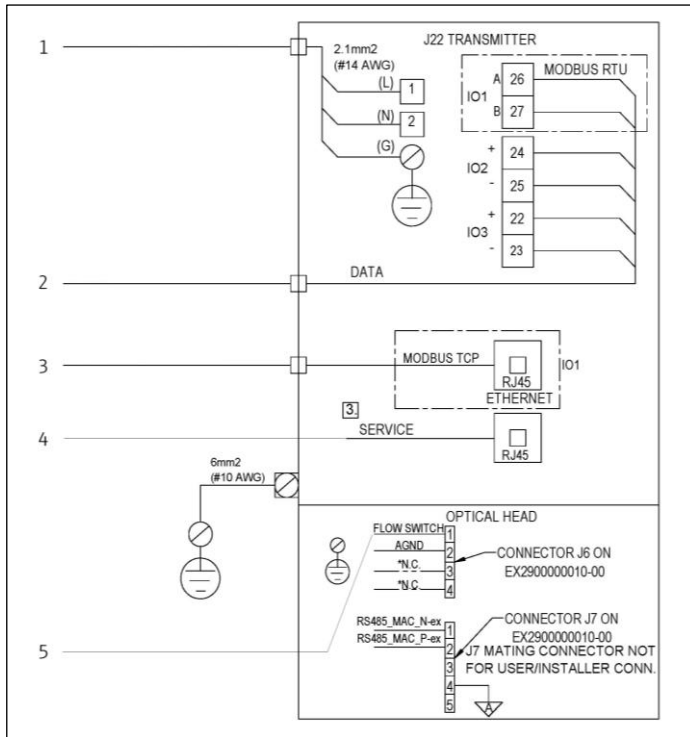

Fig 5. J22 analyzer electrical connections

1. AC 100 to 240 VAC  $\pm$  10%; DC 24 VDC  $\pm$  20%
2. IO options: Modbus RTU, 4-20 mA/Status out, Relay
3. 10/100 Ethernet (optional), Network option Modbus TCP
4. Connection to the Service port shall only be permitted temporarily by trained personnel for test, repair or overhaul of the equipment, and if the area where the equipment is installed is known to be non-hazardous
5. Flow switch connection

Terminals 26 and 27 are used for Modbus RTU (RS485) only. Terminals 26 and 27 are replaced by an RJ45 connector for Modbus TCP. N.C. is used for “No connection”.

**NOTICE**

**Connector J7 on the optical head for Endress+Hauser factory connection only.**

- ▶ Do not use for installation or customer connection.

## Enclosure, Sample Conditioning System

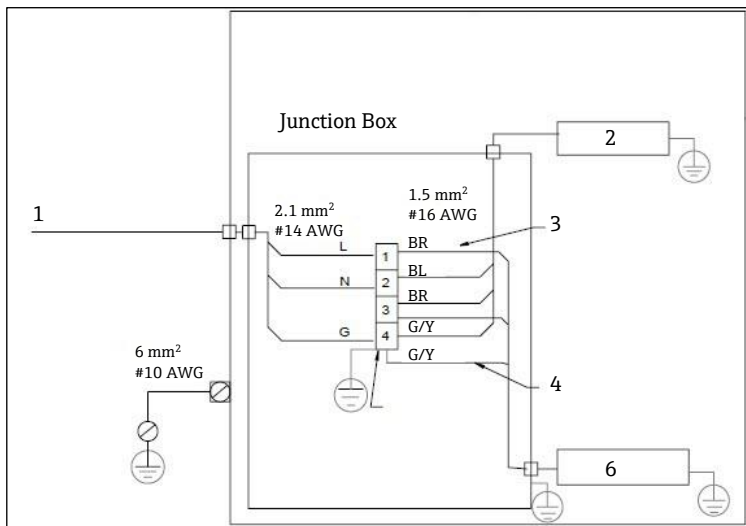

Fig 6. J22 SCS enclosure electrical connections

1. 100 to 240 VAC  $\pm$  10%, 50/60 HZ; main power
  2. Heater
  3. Blue wire is used in thermostat phase, no ground wire
  4. Ground wire is not installed for CSA thermostat. Only applies to ATEX version.
  5. Use copper wire only
  6. Thermostat
- BL Blue wire  
BR Brown wire  
G/Y Green/yellow wire

### 3.5 Electrical Wiring Requirements

#### NOTICE

**The installer is responsible for complying with all local installation codes.**

- ▶ Field wiring (Power and Signal) shall be accomplished using wiring methods approved for hazardous locations as per IEC 60079-14.
- ▶ Use copper conductors only.
- ▶ For models of the J22 TDLAS Gas Analyzer with SCS mounted within an enclosure, the inner sheath of the supply cable for the heater circuit shall be sheathed with thermoplastic, thermosetting, or elastomeric material. It shall be circular and compact. Any bedding or sheath shall be extruded. Fillers, if any, shall be non-hygroscopic.
- ▶ The minimum length of the cable shall exceed 3 meters.

### 3.5.1 Wire temperature rating and torque

- -40 °C to 105 °C
- Terminal block screw torque: 1.2 N m (10 in-lbf)

### 3.5.2 Cable entries

After installing all interconnecting wiring or cabling, make sure any remaining conduit or cable entries are plugged with certified accessories according to the intended use of the product.

Thread lubricant must be applied on all conduit hub threaded connections. Using Syntheses Glep1 or equivalent lubricant on all conduit screw thread is recommended.

#### NOTICE

- ▶ Conduit seals and glands specific to the application should be used where appropriate in compliance with local regulations.
- ▶ Models of the J22 TDLAS Gas Analyzer with enclosed SCS featuring a heater with optional imperial connections, a suitable equipment seal shall be installed within 5 cm. (2 in.) of the outer enclosure wall of the heating circuit.

### 3.5.3 Threaded entries

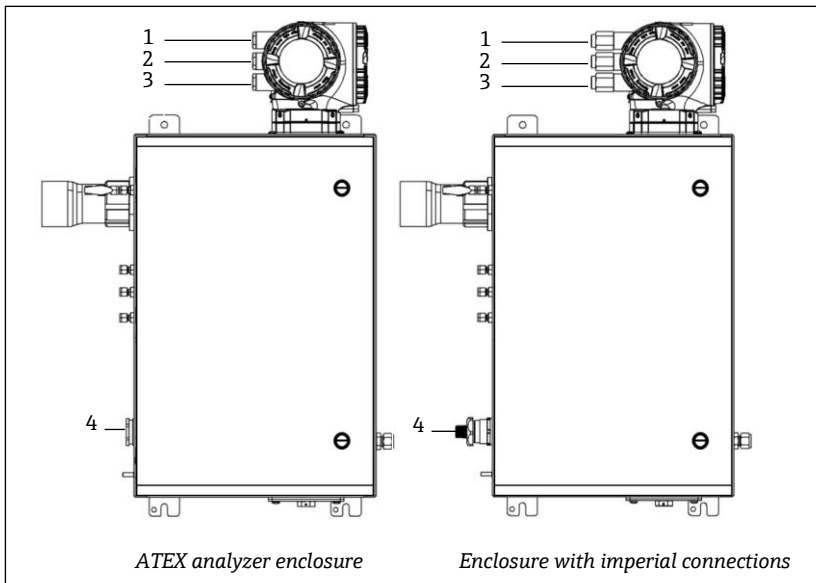

Fig 7. J22 threaded entries

| Cable Entry | Description             | ATEX, IECEx | Optional imperial connections |
|-------------|-------------------------|-------------|-------------------------------|
| 1           | Controller power        | M20 x 1.5   | 1/2 in. NPTF                  |
| 2           | Modbus output           | M20 x 1.5   | 1/2 in. NPTF                  |
| 3           | (2) Configurable IO     | M20 x 1.5   | 1/2 in. NPTF                  |
| 4           | Heater power (optional) | M25 x 1.5   | 1/2 in. NPTM                  |

Table 6. Threaded entry descriptions

Threaded entry locations for the panel configuration are the same as shown for the enclosed sample system above.

### 3.5.4 Cables Type

The standard ANSI/TIA/EIA-568-B.2 Annex specifies CAT5 as the minimum used for Ethernet/IP. CAT5e and CAT 6 are recommended.

## 3.6 IS Flow Switch Connection Requirements

The J22 TDLAS Gas Analyzer can be offered with a variable flow meter equipped with an optional mechanical display and reed contact to measure the volume flow of flammable and non-flammable gases. See electrical parameters in [Analyzer Technical Specifications](#) → .

### 3.6.1 Conditions of use

Installation shall be in accordance with IEC 60079-14.

The maximum temperature of terminals, cable glands and wires should be greater than 60 °C dependent of ambient and product temperature. The variable area flow meter with coated parts shall be installed and maintained such that the risk of electrostatic discharge is minimized.

## 3.7 Connection Values: Signal Circuits

### 3.7.1 Terminal assignment

| Input Supply Voltage |       | Input/Output 1                 |        | Input/Output 2   |        | Input/Output 3 |        |
|----------------------|-------|--------------------------------|--------|--|--------|----------------|--------|
| 1 (+)                | 2 (-) | 26 (B)                         | 27 (A) | 24 (+)   | 25 (-) | 22 (+)         | 23 (-) |
|                      |       | Modbus RS485 only <sup>2</sup> |        | Device-specific terminal assignment: refer to adhesive label on terminal cover |        |                |        |

Table 7. Controller supply voltage, outputs

### 3.7.2 Safety-related values

Refer to [Analyzer Technical Specifications](#) → .11

### 3.7.3 Modbus interface cable specification

|                          |   |
|--------------------------|---|
| Cable type               | A   |
| Characteristic impedance | 135 to 165Ω at a measuring frequency of 3 to 20 MHz |
| Cable capacitance        | < 30 pF/m   |
| Wire cross-section       | > 0.34 mm <sup>2</sup> (22 AWG)                     |
| Cable type               | Twisted pairs                                       |
| Loop resistance          | ≤ 110Ω/km   |

Table 8. Modbus interface cable specification

<sup>2</sup> Terminals 26 and 27 are replaced by an RJ45 connector for Modbus TCP/IP.

### 3.8 Electrical Circuit Breakers

The main electronic assembly shall be protected by an overcurrent protection rated for 10 amp or less.

**NOTICE**

**The breaker shall not interrupt the protective earth conductor.**

- ▶ If the breaker in the customer-provided power distribution panel or switch is the primary means of disconnecting the power from the analyzer, locate the analyzer so that the power distribution panel is in close proximity to the equipment and within easy reach of the operator.

### 3.9 Connecting the Gas Supply

Consult the layout and flow diagrams in the system drawings in the Operator’s Manual for supply and return port locations. All work must be performed by technicians qualified in pneumatic tubing.

**WARNING**

**Process samples may contain hazardous material in potentially flammable and/or toxic concentrations.**

- ▶ Personnel should have a thorough knowledge and understanding of the physical properties and safety precautions for the sample contents before connecting the gas supply.

### 3.10 Sample System Heater

The purpose of the optional heater is to maintain the temperature of the sample system to avoid condensation in cold weather.

|                           |   |
|---------------------------|---|
| <b>Manufacturer</b>       | Intertec                                    |
| <b>Power</b>              | AC 100-240 V tolerance ± 10%, 50/60 Hz, 80W |
| <b>Ingress Protection</b> | IP 68                                       |

*Table 9. Sample system heater specification*

## 4 Equipment Operation

### CAUTION

- ▶ The safety of the analyzer is the responsibility of the installer and the organization he/she represents.
- ▶ Mounting hardware used for wall-mounting the J22 must be able to support four times the weight of the approximately 19 kg (40 lbs) to 43 kg (95 lbs) depending on configuration).

### 4.1 Operating Controls

The J22 is operated using the optical touch pad. Basic operating parameters are provided in the Operator's manual in [Associated Documentation](#) → .

### 4.2 Commissioning

1. Power system on.
2. Set flow rates and pressure for system as specified in the system drawings provided in the Operator's manual.
3. Ensure sample vent has an unrestricted connection to atmosphere or flare, as specified.

### NOTICE

- ▶ The temperature of the process medium shall be within the ambient temperature rating of the equipment.
- ▶ Do not exceed specified pressure setting or equipment damage may occur.

### 4.3 Decommissioning

#### 4.3.1 Intermittent operation

If the analyzer will be stored or shut down for a short time period, follow the instructions for isolating the measurement cell and sample conditioning system (SCS).

1. Purge the system:
  - a. Shut off the process gas flow.
  - b. Allow all residual gas to dissipate from the lines.
  - c. Connect a nitrogen (N<sub>2</sub>) purge supply, regulated to the specified sample supply pressure, to the sample supply port.
  - d. Confirm that any valves controlling the sample flow effluent to the low pressure flare or atmospheric vent are open.
  - e. Turn on the purge supply to purge the system and clear any residual process gases.



- f. Turn off the purge supply.
  - g. Allow all residual gas to dissipate from the lines.
  - h. Close all valves controlling the sample flow effluent to the low pressure flare or atmospheric vent.
2. Disconnect electrical connections to the system:
    - a. Disconnect power to the system.

 **CAUTION**

- ▶ Confirm the power source is disconnected at the switch or circuit breaker. Make sure the switch or breaker is in the “OFF” position and locked with a padlock.
- b. Confirm all digital/analog signals are turned off at the location from which they are being monitored.
  - c. Disconnect the phase and neutral wires from the analyzer.
  - d. Disconnect the protective ground wire from the analyzer system.
3. Disconnect all tubing and signal connections.
  4. Cap all inlets and outlets to prevent foreign material such as dust or water from entering the system).
  5. Ensure the analyzer is free from dust, oils or any foreign material. Follow instructions found in “To clean the J22 exterior”.
  6. Pack the equipment in the original packaging in which it was shipped, if available. If the original packaging material is no longer available, the equipment should be adequately secured (to prevent excessive shock or vibration).
  7. If returning the analyzer to the factory, complete the Decontamination Form provided by Endress+Hauser and attach to the outside of the shipping package as instructed before shipping. Refer to [Service](#) → .

## 5 Maintenance and Service

Any repairs carried out by the customer or on behalf of the customer must be recorded in a site dossier and kept available for inspectors. For more information on system repairs and replacements, see [Associated Documentation](#) → .

### WARNING

**Process samples may contain hazardous material in potentially flammable and/or toxic concentrations.**

- ▶ Personnel should have a thorough knowledge and understanding of the physical properties and safety precautions for the sample contents before connecting the gas supply.

### 5.1 Cleaning and Decontamination

#### To clean the J22 exterior

The housing should be cleaned only with a damp cloth to avoid electrostatic discharge.

#### NOTICE

- ▶ Never use vinyl acetate, acetone or other organic solvents to clean the analyzer housing or labels.

### 5.2 Troubleshooting and Repairs

#### 5.2.1 Cleaning the cell mirror

If contamination makes its way into the cell and accumulates on the internal optics, a **DC spectrum power range exceeded** fault will result. If mirror contamination is suspected, contact Service before attempting to clean the mirrors. If advised to do so, use the following procedure.

#### NOTICE

- ▶ This procedure should be used **ONLY** when necessary and is not part of routine maintenance. To avoid compromising the system warranty, contact [Service](#) →  before cleaning mirrors.



## INVISIBLE LASER RADIATION

The sample cell assembly contains a low power, 35 mW maximum, CW Class 3b invisible laser with a wavelength between 750 to 3000 nm.

- ▶ Never open the sample cell flanges or the optical assembly unless the power is turned off.

## Tools and materials

- Lens cleaning cloth (Cole-Parmer® EW-33677-00 TEXWIPE® Alphawipe® Low-Particulate Clean Room Wipes or equivalent)
- Reagent-grade isopropyl alcohol (Cole-Parmer® EW-88361-80 or equivalent)
- Small drop dispenser bottle (Nalgene® 2414 FEP Drop Dispenser Bottle or equivalent)
- Acetone-impenetrable gloves (North NOR CE412W Nitrile Chemsoft™ CE Clean room Gloves or equivalent)
- Hemostat (Fisherbrand™ 13-812-24 Rochester-Pean Serrated Forceps)
- Bulb blower or dry compressed air/nitrogen
- Torque wrench
- 3 mm Hex driver
- Non-outgassing grease
- Flashlight

## To clean the cell mirror

1. Power down the analyzer.
2. Isolate the SCS from the process sample tap.



- ▶ All valves, regulators, switches, etc. should be operated in accordance with site lock-out/tag-out procedures.
3. If possible, purge the system with nitrogen for 10 minutes.



**Process samples may contain hazardous material in potentially flammable and/or toxic concentrations.**

- ▶ Personnel should have a thorough knowledge and understanding of the physical properties and safety precautions for the sample contents before operating the SCS.
4. On the underside of the SCS enclosure, remove the plate covering the measurement cell located inside the enclosure and set aside. Retain screws.

Disregard step 4 for analyzers without an enclosed sample conditioning system (SCS).

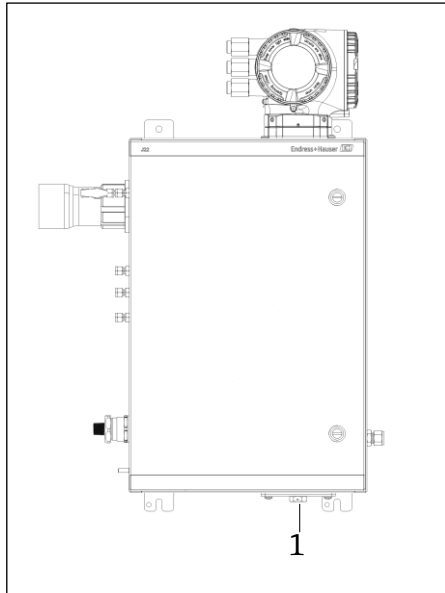

Fig 8. J22 measurement cell access  
1 Measurement cell plate on underside of SCS enclosure

5. Mark or note the mirror orientation. This is critical to restoring system performance upon reassembly after cleaning.



### INVISIBLE LASER RADIATION

The sample cell assembly contains a low power, 35 mW maximum, CW Class 3b invisible laser with a wavelength between 750 to 3000 nm.

- ▶ Never open the sample cell flanges or the optical assembly unless the power is turned off.
6. Gently remove the mirror assembly from the cell using a 3 mm hex driver to remove the socket head cap screws and set on a clean, stable and flat surface.

### NOTICE

**Never touch the coated surfaces of the mirror.**

- ▶ Always handle the optical assembly by the edge of the mount.
7. Look inside the sample cell at the top window using a flashlight to ensure that there is no contamination on the top window.

8. Clean the mirror:
  - a. Put on clean acetone-impenetrable gloves.
  - b. Double-fold a clean sheet of lens cleaning cloth and clamp near and along the fold with the hemostats or fingers to form a “brush.”
  - c. Place a few drops of isopropyl alcohol onto the mirror and rotate the mirror to spread the liquid evenly across the mirror surface.
  - d. With gentle, uniform pressure, wipe the mirror from one edge to the other with the cleaning cloth only once and only in one direction to remove the contamination. Discard the cloth.

**NOTICE**

- ▶ Never rub an optical surface, especially with dry tissues. Doing this can scratch the coated surface.
- e. Repeat with a clean sheet of lens cleaning cloth to remove the streak left by the first wipe.
  - f. Repeat, if necessary, until there is no visible contamination on the mirror.
9. Replace the O-ring adding a very thin layer of grease. Ensure it is properly seated.
  10. Carefully replace the mirror assembly onto the cell (it is not necessary to maintain the original orientation).
  11. Tighten the socket head cap screws evenly with a torque wrench to 3.5 Nm (30 in-lb).
  12. Replace the plate on the outside of the SCS enclosure. Disregard this step for analyzers without an enclosed SCS.

### 5.2.2 Replacing the membrane separator filter

Make sure that a membrane separator filter is operating normally. If liquid enters the cell and accumulates on the internal optics, a **DC spectrum power range exceeded** fault will result.

#### To replace the membrane separator filter

1. Close the sample supply valve.
2. Unscrew the cap from the membrane separator.

#### If the membrane filter is dry:

3. Check if there are any contaminants or discoloring of the white membrane. If yes, the filter should be replaced.
4. Remove the O-ring and replace the membrane filter.
5. Replace the O-ring on top of the membrane filter.
6. Place the cap back onto the membrane separator and tighten.

7. Check upstream of the membrane for liquid contamination and clean and dry out before reopening the sample supply valve.

**If liquid or contaminants are detected on the filter:**

3. Drain any liquids and clean with isopropyl alcohol.
4. Clean any liquids or contaminants from the base of the membrane separator.
5. Replace the filter and the O-ring.
6. Place the cap onto the membrane separator and hand tighten.
7. Check upstream of the membrane for liquid contamination and clean and dry out before reopening the sample supply valve.

**5.2.3 Enclosure purge (optional)**

The optional enclosure purge is typically elected when the sample gas contains high concentrations of H<sub>2</sub>S. When maintenance of the J22 is required, follow one of the two methods described below prior to opening the enclosure door.

**To purge the enclosure with a gas sensor**

- ▶ Ensure an appropriate sensor is used based on the toxic components in the process gas stream.
1. Allow the sample gas to continue flowing through the system.
  2. Open the tee fitting cap on the exhaust port on the lower right side of the enclosure and insert a sensor to determine if there is H<sub>2</sub>S inside the enclosure.
  3. If no hazardous gas is detected, proceed with opening the enclosure door.
  4. If hazardous gas is detected, follow the instructions below for purging the enclosure.

**To purge the enclosure without a gas sensor**

1. Turn off the sample gas to the system.
2. Connect the purge gas to the purge inlet on the upper right side of the enclosure.
3. Open the exhaust on the bottom right side of the enclosure and connect a piece of tubing that vents to safe area.
4. Input the purge gas at 5 liters per minute.
5. Operate the purge for 22 minutes.

**5.2.4 Sample system purge (optional)**

1. Shut off gas to the analyzer.
2. Ensure the vent and bypass, if present, are open.
3. Connect the purge gas to 'sample purge in' port.

4. Switch the gas select valve from 'sample in' to 'purge in'.
5. Set the flow rate to 1 liter per minute and run the purge for at least 10 minutes for safety.

### 5.2.5 Repair verification

When repairs have been completed correctly, alarms will clear from the system.

#### CAUTION

**Residual risk. Some capacitors may remain charged with high voltage in the case of a single fault.**

- ▶ Allow 10 minutes before controller covers are opened.

### 5.2.6 Power termination covers

Confirm the termination cover is closed before initiating operation or after a repair event. Should the cover become damaged, it must be replaced to avoid potential safety risk.

## 5.3 Spare Parts

All parts required for operation of the J22 TDLAS Gas Analyzer must be supplied by Endress+Hauser or an authorized agent. Refer to the *J22 TDLAS Gas Analyzer Operating Instructions* in [Associated Documentation](#) →  for a complete list of available spare parts.

## 5.4 Service

For Service, refer to our website (<https://www.endress.com/contact>) for the list of local sales channels in your area.

[www.addresses.endress.com](http://www.addresses.endress.com)

---