

Operating Instructions

Compact thermometer

For general or hygienic applications



Table of contents

1	Document information	3	10	Accessories	17
1.1	Document function	3	10.1	Device-specific accessories	17
1.2	Symbols	3	10.2	Communication-specific accessories	19
2	Basic safety instructions	4	11	Technical data	21
2.1	Requirements for the personnel	4	11.1	Input	21
2.2	Intended use	5	11.2	Output	21
2.3	Operational safety	5	11.3	Power supply	22
2.4	Product safety	5	11.4	Performance characteristics	22
2.5	IT security	5	11.5	Environment	24
3	Incoming acceptance and product identification	6	11.6	Process	25
3.1	Incoming acceptance	6	11.7	Mechanical construction	27
3.2	Product identification	6	11.8	Certificates and approvals	37
3.3	Name and address of manufacturer	7			
3.4	Storage and transport	7			
4	Mounting	8			
4.1	Mounting requirements	8			
4.2	Mounting the thermometer	11			
4.3	Post-mounting check	12			
5	Electrical connection	12			
5.1	Connection conditions	12			
5.2	Connecting the measuring device	12			
5.3	Ensuring the degree of protection	13			
5.4	Post-connection check	13			
6	Commissioning	14			
6.1	Post-installation check	14			
6.2	Switching on the measuring device	14			
6.3	Configuring the measuring device	14			
7	Diagnostics and troubleshooting	14			
7.1	General troubleshooting	14			
8	Maintenance	15			
8.1	Cleaning	15			
8.2	Services	15			
9	Repair	15			
9.1	Spare parts	15			
9.2	Return	16			
9.3	Disposal	16			

1 Document information

1.1 Document function

These Operating Instructions contain all the information required in the various life cycle phases of the device: from product identification, incoming acceptance and storage, to installation, connection, operation and commissioning, through to troubleshooting, maintenance and disposal.

1.2 Symbols

1.2.1 Safety symbols

DANGER

This symbol alerts you to a dangerous situation. Failure to avoid this situation will result in serious or fatal injury.

WARNING

This symbol alerts you to a dangerous situation. Failure to avoid this situation can result in serious or fatal injury.





CAUTION

This symbol alerts you to a dangerous situation. Failure to avoid this situation can result in minor or medium injury.





NOTICE





This symbol contains information on procedures and other facts which do not result in personal injury.

1.2.2 Electrical symbols



Symbol	Meaning	Symbol	Meaning
	Direct current		Alternating current
	Direct and alternating current		Ground connection A grounded terminal which, as far as the operator is concerned, is grounded via a grounding system.

1.2.3 Symbols for certain types of information

Symbol	Meaning	Symbol	Meaning
	Allowed Procedures, processes or actions that are permitted.		Preferred Procedures, processes or actions that are preferred.
	Forbidden Procedures, processes or actions that are forbidden.		Tip Indicates additional information.

Symbol	Meaning	Symbol	Meaning
	Reference to documentation		Reference to page
	Reference to graphic	1., 2., 3. ...	Series of steps
	Result of a step		Visual inspection

1.2.4 Symbols in graphics

Symbol	Meaning	Symbol	Meaning
1, 2, 3, ...	Item numbers	1., 2., 3. ...	Series of steps
A, B, C, ...	Views	A-A, B-B, C-C, ...	Sections
	Hazardous area		Safe area (non-hazardous area)

1.2.5 Tool symbols

Symbol	Meaning
 A0011222	Open-ended wrench

2 Basic safety instructions

2.1 Requirements for the personnel

The personnel for installation, commissioning, diagnostics and maintenance must fulfill the following requirements:

- ▶ Trained, qualified specialists must have a relevant qualification for this specific function and task.
- ▶ Are authorized by the plant owner/operator.
- ▶ Are familiar with federal/national regulations.
- ▶ Before starting work, read and understand the instructions in the manual and supplementary documentation as well as the certificates (depending on the application).
- ▶ Follow instructions and comply with basic conditions.

The operating personnel must fulfill the following requirements:

- ▶ Are instructed and authorized according to the requirements of the task by the facility's owner-operator.
- ▶ Follow the instructions in this manual.

2.2 Intended use

- The device is a compact thermometer for industrial temperature measurement.
- The manufacturer is not liable for damage caused by improper or non-designated use.

2.3 Operational safety

CAUTION

Risk of injury!

- ▶ Operate the device only if it is in proper technical condition, free from errors and faults.
- ▶ The operator is responsible for the interference-free operation of the device.

NOTICE

Modifications to the device.

- ▶ Unauthorized modifications to the device are not permitted and can lead to unforeseeable dangers.

Repair

To ensure continued operational safety and reliability:

- ▶ Carry out repairs on the device only if they are expressly permitted.
- ▶ Observe federal/national regulations pertaining to the repair of an electrical device.
- ▶ Use only original spare parts and accessories from the manufacturer.

2.4 Product safety

This measuring device is designed in accordance with good engineering practice to meet state-of-the-art safety requirements, has been tested, and left the factory in a condition in which it is safe to operate.

It meets general safety standards and legal requirements. It also complies with the EU directives listed in the device-specific EU Declaration of Conformity. The manufacturer confirms this by affixing the CE mark to the device.

2.5 IT security

Our warranty is valid only if the product is installed and used as described in the Operating Instructions. The product is equipped with security mechanisms to protect it against any inadvertent changes to the settings.

IT security measures, which provide additional protection for the product and associated data transfer, must be implemented by the operators themselves in line with their security standards.

3 Incoming acceptance and product identification

3.1 Incoming acceptance

Proceed as follows on receipt of the device:

1. Check whether the packaging is intact.
2. If damage is discovered:
Report all damage immediately to the manufacturer.
3. Do not install damaged components, as the manufacturer cannot otherwise guarantee the material resistance or compliance with the original safety requirements, and can also not be held responsible for the consequences that may result.
4. Compare the scope of delivery against the contents of your order.
5. Remove all the packaging material used for transportation.
6. Do the data on the nameplate match the ordering information on the delivery note?
7. Are the technical documentation and all other necessary documents provided, e.g. certificates?



If one of the conditions is not satisfied, contact your Sales Center.

3.2 Product identification

The following options are available for the identification of the device:

Nameplate specifications

3.2.1 Nameplate

The correct device?

1. Check the data on the nameplate of the device.
2. Compare against the requirements of the measuring point.

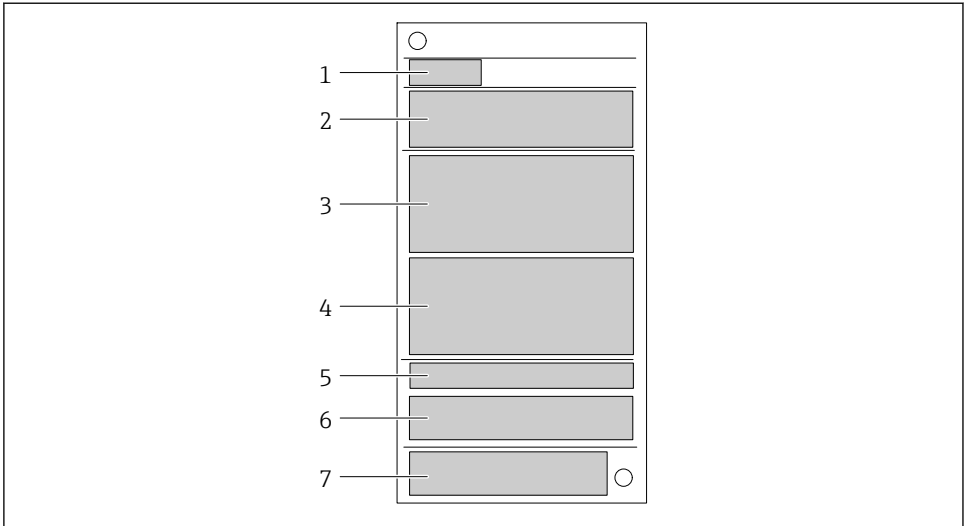

A0040277

1 Sample graphic

- 1 Device name
- 2 Order code, serial number
- 3 Tag name (TAG)
- 4 Technical values
- 5 Degree of protection
- 6 Pin assignment
- 7 Approvals with symbols

3.2.2 Scope of delivery

The scope of delivery comprises:

- Compact thermometer
- Printed copy of the Brief Operating Instructions
- Accessories ordered

3.3 Name and address of manufacturer

Name of manufacturer:	Endress+Hauser Wetzer GmbH + Co. KG
Address of manufacturer:	Obere Wank 1, D-87484 Nesselwang or www.endress.com

3.4 Storage and transport

Storage temperature: -40 to +85 °C (-40 to +185 °F)

Maximum relative humidity: < 95 % as per IEC 60068-2-30



 Pack the device for storage and transportation in such a way that it is reliably protected against impact and external influences. The original packaging offers the best protection.

Avoid the following environmental influences during storage:

- direct sunlight
- proximity to hot objects
- mechanical vibration
- aggressive media

4 Mounting

4.1 Mounting requirements

 Information on the conditions that must be present at the mounting location to ensure correct use (e.g. ambient temperature, degree of protection, climate class etc.), and information on the device dimensions, see the 'Technical data' →  21

4.1.1 Orientation

No restrictions. However, self-draining in the process must be guaranteed. If there is an opening to detect leaks at the process connection, this opening must be at the lowest possible point.

4.1.2 Installation instructions

The immersion length of the compact thermometer can considerably influence the accuracy. If the immersion length is too short, measurement errors can occur as a result of heat conduction via the process connection and the vessel wall. If installing in a pipe then the immersion length should ideally be half of the pipe diameter.

Installation possibilities: pipes, tanks or other plant components.

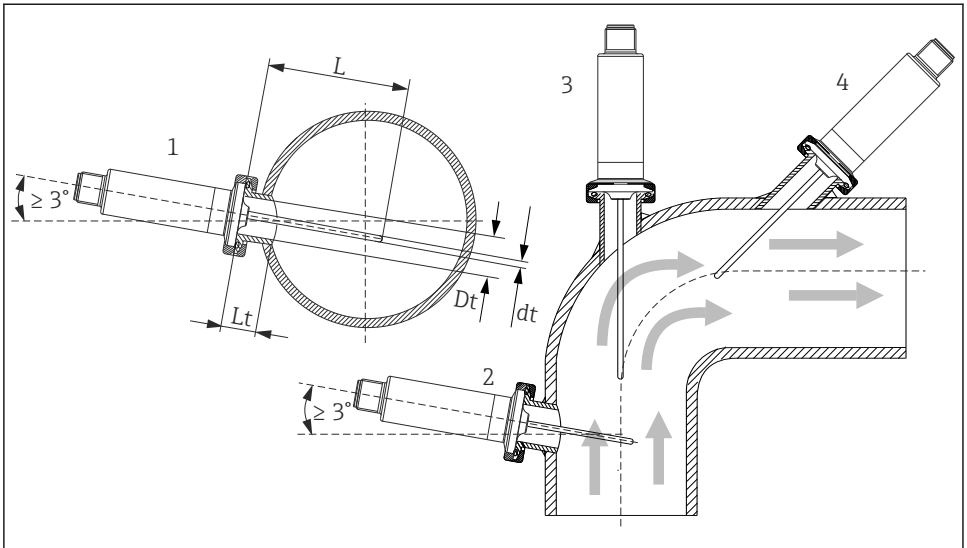

A0012591

2 Installation examples

- 1, 2 Perpendicular to flow direction, installed at a minimum angle of 3° to ensure self-draining
- 3 On elbows
- 4 Inclined installation in pipes with a small nominal diameter
- L Insertion length



The requirements of the EHEDG and the 3-A Sanitary Standard must be adhered to.

Installation instruction EHEDG/cleanability: $Lt \leq (Dt-dt)$

Installation instruction 3-A/cleanability: $Lt \leq 2(Dt-dt)$



In the case of pipes with a small nominal diameter, it is advisable for the tip of the thermometer to project well into the process so that it extends past the pipe axis. Installation at an angle (4) could be another solution. When determining the immersion or insertion length, all the parameters of the thermometer and of the medium to be measured must be taken into account (e.g. flow velocity, process pressure).

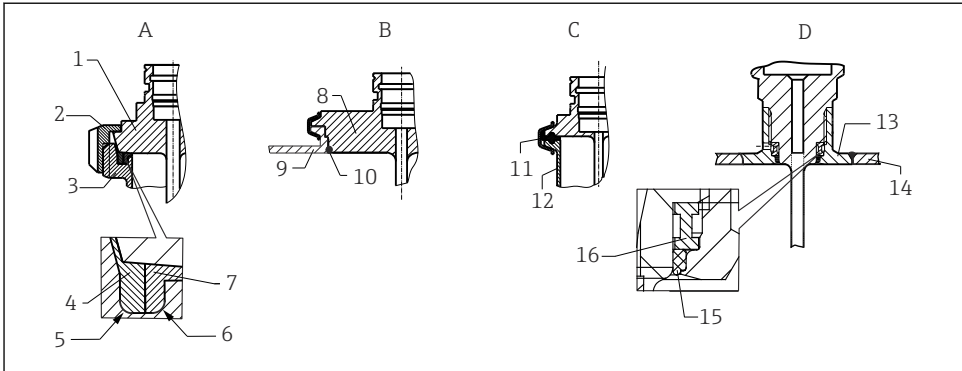

A0040345

☑ 3 Detailed installation instructions for hygiene-compliant installation

A Milk pipe connection according to DIN 11851, only in conjunction with EHEDG-certified, self-centering sealing ring

1 Sensor with milk pipe connection

2 Thread adapter nut

3 Counterpart connection

4 Centering ring

5 RO.4

6 RO.4

7 Sealing ring

B Varivent® process connection for VARINLINE® housing

8 Sensor with Varivent connection

9 Counterpart connection

10 O-ring

C Clamp according to ISO 2852

11 Molded seal

12 Counterpart connection

D Process connection Liquiphant-M G1", horizontal installation

13 Weld-in adapter

14 Vessel wall

15 O-ring

16 Thrust collar

i The counterparts for the process connections and the seals or sealing rings are not supplied with the thermometer. weld-in adapters with associated seal kits are available as accessories (see 'Accessories').

NOTICE

The following actions must be taken if a sealing ring (O-ring) or seal fails:

- ▶ The thermometer must be removed.
- ▶ The thread and the O-ring joint/sealing surface must be cleaned.
- ▶ The sealing ring or seal must be replaced.
- ▶ CIP must be performed after installation.

In the case of weld-in connections, exercise the necessary degree of care when performing the welding work on the process side:

1. Use suitable welding material.
2. Flush-weld or weld with welding radius ≥ 3.2 mm (0.13 in).
3. Avoid crevices, folds or gaps.
4. Ensure the surface is honed and mechanically polished, $R_a \leq 0.76$ μm (30 μin).

Pay attention to the following when installing the thermometer to ensure that the cleanability is not affected:

1. The installed sensor is suitable for CIP (cleaning in place). Cleaning is performed together with the pipe or tank. In the case of internal tank fixtures using process connection nozzles, it is important to ensure that the cleaning assembly sprays this area directly so that it is cleaned properly.
2. The Varivent® connections enable flush-mounted installation.

4.2 Mounting the thermometer

Proceed as follows to mount the device:

1. The permitted loading capacity of the process connections can be found in the relevant standards.
2. The process connection and compression fitting must comply with the maximum specified process pressure.
3. Make sure that the device is installed and secured before applying the process pressure.
4. Adjust the loading capacity of the thermowell to the process conditions.
5. It may be necessary to calculate the static and dynamic loading capacity.



Please contact the supplier if you have any questions.

4.2.1 Cylindrical threads

NOTICE

Seals must be used for cylindrical threads.

In the case of combined thermometer and thermowell assemblies, these seals are already installed (depending on the version ordered).

- ▶ The system operator is required to verify the suitability of this seal with regard to the operating conditions.

Threaded version	Tightening torque [Nm]
Process connection, metal sealing system	10
Compression fitting, cylindrical, Elastosil seal	5

1. Replace with a suitable seal if necessary.
2. Replace the seals following disassembly.
3. As all threads must be firmly tightened, using the appropriate torques.

4.2.2 Tapered threads

- ▶ The operator must verify if additional sealing by means of PTFE tape, hemp or an additional welded seam, for example, is necessary in the case of NPT threads or other tapered threads.

4.3 Post-mounting check

<input type="checkbox"/>	Is the device undamaged (visual inspection)?
<input type="checkbox"/>	Is the device correctly secured?
<input type="checkbox"/>	Does the device correspond to the specifications at the measuring point, e.g. ambient temperature, measuring range etc.? →  21

5 Electrical connection

5.1 Connection conditions



If the 3-A Standard is required, electrical connecting cables must be smooth, corrosion-resistant and easy to clean.

5.2 Connecting the measuring device

NOTICE

Damage to the device!

- ▶ Do not overtighten the M12 plug, as this could damage the device. Maximum torque: 0.4 Nm (M12 knurl)

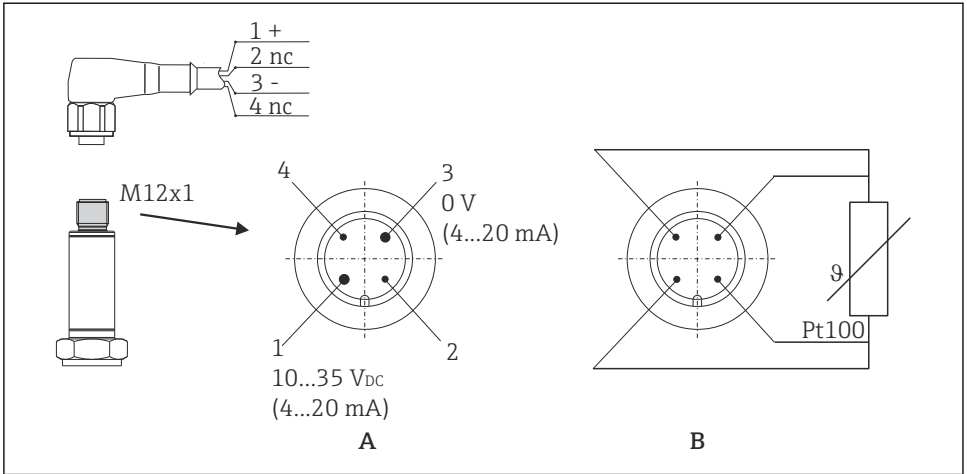

A0020176

4 Pin assignment, device plug

- A Version with transmitter, M12 plug, 4-pin
- B Version without transmitter, Pt100, 4-wire connection

1: Pin 1	Power supply 10 to 35 V _{DC} Current output 4 to 20 Cable connection, wire color brown = BN
2: Pin 2	Connection of PC configuration cable - shortened pin Cable connection, wire color white = WH
3: Pin 3	Power supply 0 V _{DC} Current output 4 to 20 Cable connection, wire color blue = BU
4: Pin 4	Connection of PC configuration cable - shortened pin Cable connection, wire color black = BK

5.3 Ensuring the degree of protection

The indicated degree of protection is ensured if the M12x1 cable connector meets the required degree of tightness. For compliance with IP69 protection, suitable device connecting cables with straight or elbowed connectors are available .



5.4 Post-connection check

<input type="checkbox"/>	Are the device and cable undamaged (visual check)?
<input type="checkbox"/>	Do the mounted cables have suitable strain relief?
<input type="checkbox"/>	Does the supply voltage match the information on the nameplate?

6 Commissioning

6.1 Post-installation check

Perform the following checks prior to commissioning the measuring point:

1. Perform the post-mounting check using the checklist →  12.
2. Perform the post-connection check using the checklist →  13.

6.2 Switching on the measuring device

After applying the supply voltage, the device is in the measuring mode.

6.3 Configuring the measuring device

The compact thermometer is configured via the configuration set, for PC-programmable thermometers with the setup software and an interface for PC with USB port.



Configurable parameters	
Standard settings	<ul style="list-style-type: none"> ■ Measuring unit (°C/°F) ■ Measuring range limits: <ul style="list-style-type: none"> ■ -50 to +150 °C (-58 to +302 °F) without extension neck ■ -50 to +200 °C (-58 to +392 °F) with extension neck
Advanced settings	<ul style="list-style-type: none"> ■ Failure mode ■ Output (analog standard/inverse) ■ Filter: 0 to 8 s ■ Offset: -9.9 to +9.9 K ■ Device TAG
Service functions	Simulation (on/off)

7 Diagnostics and troubleshooting

7.1 General troubleshooting



Due to its design, the device cannot be repaired.

Problem	Possible cause	Remedial action
Device does not respond.	Supply voltage does not match the voltage specified on the nameplate.	▶ Connect the correct voltage.
Device measures incorrectly.	The device has been incorrectly connected.	▶ Check the pin assignment →  12.
	Incorrect device orientation.	▶ Install the device correctly. →  8

Problem	Possible cause	Remedial action
	Heat dissipation over the measuring point.	► Observe the installed length of the sensor.
No communication	Communication cable is not connected.	► Check wiring and cables.

Behavior of the device in the event of a fault

The behavior of the output in the event of a failure is regulated in accordance with NAMUR NE43. The current output adopts the configured failure current. →  21

8 Maintenance

No special maintenance work is required.

8.1 Cleaning

The device must be cleaned whenever necessary. Cleaning can also be done when the device is installed (e.g. CIP Cleaning in Place / SIP Sterilization in Place). When cleaning the device, care must be taken to ensure that it is not damaged.

NOTICE

Avoid damage to the device and the system

- Pay attention to the specific IP code when cleaning.

8.2 Services

Service	Description
Calibration	RTD inserts may drift depending on the application. Regular recalibration to verify accuracy is recommended. The calibration can be performed by the manufacturer or by qualified technical staff using calibration devices onsite.

9 Repair

Due to the device's particular design, it cannot be repaired.

9.1 Spare parts

1. Ask your supplier for information on available spare parts.
2. When ordering spare parts:
Indicate the serial number of the device.

Type	TMR31L	OTMR35
Adapter upgrade	✓	
Collar welding boss d6 PEEK+screw	✓	
Collar welding boss d6 PEEK w/o screw	✓	
Screw G½"+sealing taper	✓	
Cable M12x1, length 5 m	✓	
4-pin plug M12x1, cable assembly	✓	
Cable set 4p D18 IP69K	✓	
Weld-in adapter G3/4, d=50, 316L, 3.1		✓
Weld-in adapter G3/4, 316L, 3.1		✓
Welding boss for G1/2" sealing system		✓
O-ring 14.9x2.7 VMQ, FDA, 5 pcs		✓
Weld-in adapter G3/4, d=55, 316L		✓
O-ring 21.89x2.62 VMQ, FDA, 5 pcs		✓
Weld-in adapter G1, d=60, 316L		✓
Weld-in adapter G1, d=60, 316L, 3.1		✓
O-ring 28.17x3.53 VMQ, FDA, 5 pcs		✓
Thermowell TMR35, L = 83 mm, G½", 316L		✓
Compression fitting, movable	✓	

9.2 Return



If required by the Directive 2012/19/EU on waste electrical and electronic equipment (WEEE), our products are marked with the depicted symbol in order to minimize the disposal of WEEE as unsorted municipal waste. Such products may not be disposed of as unsorted municipal waste and can be returned to the manufacturer for disposal at conditions stipulated in our General Terms and Conditions or as individually agreed.

9.3 Disposal

The device contains electronic components and must, therefore, be disposed of as electronic waste in the event of disposal. Please pay particular attention to the local regulations governing waste disposal in your country. Ensure proper separation and reuse of the device components where possible.

10 Accessories

All dimensions in mm (in).

10.1 Device-specific accessories

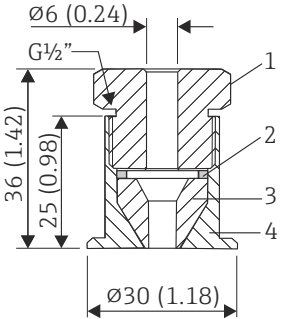
Accessories	Description
<p>Welding boss with sealing taper</p>  <p style="text-align: right; font-size: small;">A0048610</p> <p>1 Pressure screw, 303/304, width across flats 24 mm 2 Washer, 303/304 3 Sealing taper, PEEK 4 Collar welding boss, 316L</p>	<ul style="list-style-type: none"> ■ Collar welding boss movable with sealing taper, washer and pressure screw G½" ■ Material of parts in contact with the process 316L, PEEK ■ Max. process pressure 10 bar (145 psi)

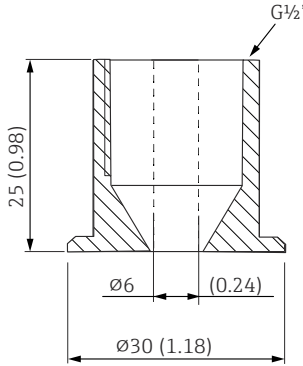
Accessories	Description
<p>Collar welding boss</p>  <p style="text-align: right; font-size: small;">A0020710</p>	<p>Material of parts in contact with the process 316L</p>

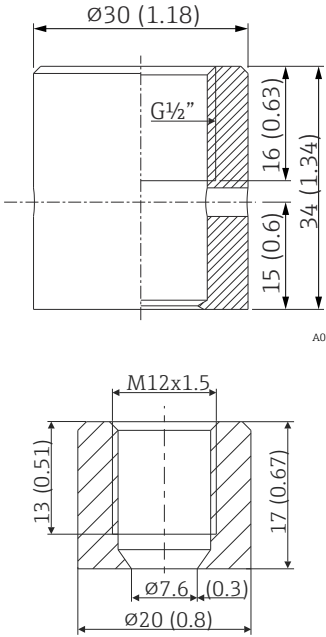
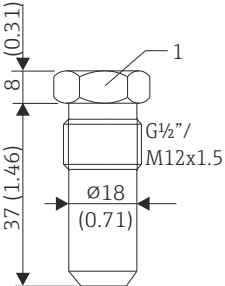
Accessories	Description
<p data-bbox="68 180 437 201">Welding boss with sealing taper (metal-metal)</p>  <p data-bbox="400 560 452 576">A0006621</p> <p data-bbox="400 874 452 890">A0018236</p>	<ul data-bbox="468 180 953 272" style="list-style-type: none"> ▪ Welding boss for G$\frac{1}{2}$" or M12x1.5 thread ▪ Metal-sealing; conical ▪ Material of parts in contact with the process 316L/1.4435 ▪ Max. process pressure 16 bar (232 PSI)
<p data-bbox="199 906 303 927">Dummy plug</p>  <p data-bbox="400 1257 452 1273">A0045726</p> <p data-bbox="68 1283 152 1303">1 AF22</p>	<ul data-bbox="468 906 930 975" style="list-style-type: none"> ▪ Dummy plug for G$\frac{1}{2}$" or M12x1.5 conical metal-sealing welding boss ▪ Material: SS 316L/1.4435

10.1.1 Weld-in adapter

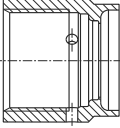
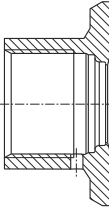
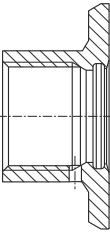
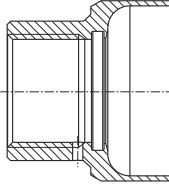
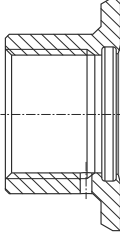
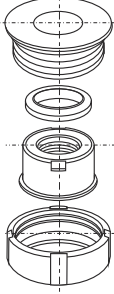
Weld-in adapter						
	A0008246	A0008251	A0008256	A0011924	A0008248	A0008253
	G ¾", d=29 for pipe-mounting	G ¾", d=50 for vessel-mounting	G ¾", d=55 with flange	G 1", d=53 without flange	G 1", d=60 with flange	G 1" adjustable
Material	316L (1.4435)	316L (1.4435)	316L (1.4435)	316L (1.4435)	316L (1.4435)	316L (1.4435)
Roughness μm (μin) process side	≤ 1.5 (59.1)	≤ 0.8 (31.5)	≤ 0.8 (31.5)	≤ 0.8 (31.5)	≤ 0.8 (31.5)	≤ 0.8 (31.5)

-  Maximum process pressure for the weld-in adapters:
- 25 bar (362 PSI) at maximum 150 °C (302 °F)
 - 40 bar (580 PSI) at maximum 100 °C (212 °F)

10.2 Communication-specific accessories

10.2.1 Coupling

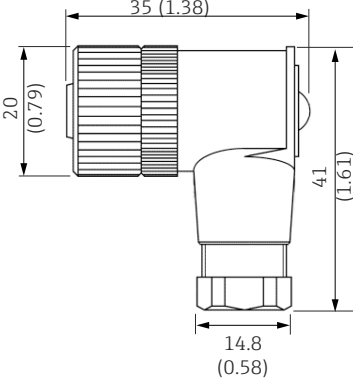
Accessories	Description
<ul style="list-style-type: none"> ■ M12x1 coupling; elbowed, for termination of connecting cable by user ■ Connection to M12x1 housing connector ■ Body materials PBT/PA ■ Cap-nut GD-Zn, nickel-plated ■ IP67 degree of protection (fully locked) ■ Voltage: max. 250 V ■ Current carrying capacity: max. 4 A ■ Temperature: -40 to 85 °C 	 <p style="text-align: right;">A0020722</p>

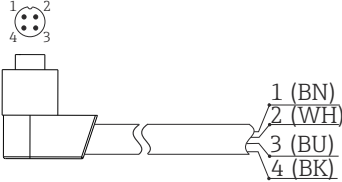
Accessories	Description
<ul style="list-style-type: none"> ■ PVC cable, 4 x 0.34 mm² (22 AWG) with M12x1 coupling, elbow plug, screw plug, length 5 m (16.4 ft) ■ IP69K protection (optional) ■ Voltage: max. 250 V ■ Current carrying capacity: max. 4 A ■ Temperature: -25 to 70 °C <p>Wire colors:</p> <ul style="list-style-type: none"> ■ 1 = BN brown ■ 2 = WH white ■ 3 = BU blue ■ 4 = BK black 	 <p style="text-align: right;">A0020723</p>

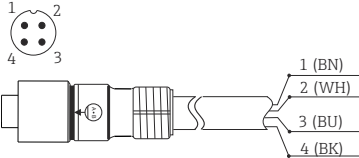
Accessories	Description
<ul style="list-style-type: none"> ■ PVC cable, 4 x 0.34 mm² (22 AWG) with M12x1 coupling nut made of epoxy coated zinc, straight socket contact, screw plug, 5 m (16.4 ft) ■ IP69K protection (optional) ■ Voltage: max. 250 V ■ Current carrying capacity: max. 4 A ■ Temperature: -20 to 105 °C <p>Wire colors:</p> <ul style="list-style-type: none"> ■ 1 = BN brown ■ 2 = WH white ■ 3 = BU blue ■ 4 = BK black 	 <p style="text-align: right;">A0020725</p>

11 Technical data

11.1 Input

11.1.1 Measuring range

Pt100 (TF) according to IEC 60751

Without extension neck	-50 to +150 °C (-58 to +302 °F)
With extension neck	-50 to +200 °C (-58 to +392 °F)

Min. span = 10 K (18 °F)

11.2 Output

11.2.1 Output signal

Sensor output	Pt100, 4-wire connection, class A
Analog output	4 to 20 mA; variable measuring range

11.2.2 Signal on alarm

The signal on alarm is generated if the measuring information is missing or not valid.

In the 4 to 20 mA mode, the device transmits the failure information according to NAMUR NE43:

Underranging	Linear drop from 4.0 to 3.8 mA
Overranging	Linear increase from 20.0 to 20.5 mA
Failure e.g. sensor defective	<p>≤ 3.6 mA (low) or ≥ 21 mA (high) can be selected</p> <p>The high alarm setting can be set between 21.5 mA and 23 mA, thus providing the flexibility needed to meet the requirements of various control systems.</p>

11.2.3 Load

$$R_{b \max} = (U_b \max - 10 \text{ V}) / 0.023 \text{ A (current output)}$$

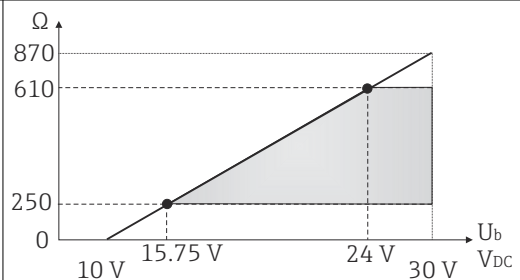

A0048582

11.2.4 Linearization/transmission behavior

Temperature - linear

11.3 Power supply

11.3.1 Supply voltage

U_b	10 to 35 V _{DC}
-------	--------------------------

11.3.2 Power supply failure

- To meet electrical safety according to CAN/CSA-C22.2 No. 61010-1 or UL 61010-1, the device may only be powered by a power supply unit with a limited energy electric circuit in accordance with UL/EN/IEC 61010-1 chapter 9.4 or Class 2 according to UL 1310, "SELV or Class 2 circuit".
- Behavior in the event of overvoltage (> 30 V)
The device works continuously up to 35 V_{DC} without any damage. If the supply voltage is exceeded, the specified characteristics are no longer guaranteed.
- Behavior in the event of undervoltage
If the supply voltage falls below the minimum value ~ 7 V, the device switches off in a defined manner (status as if not supplied with power).

11.3.3 Input current required

≤ 3.5 mA for 4 to 20 mA

11.3.4 Maximum current consumption

≤ 23 mA for 4 to 20 mA

11.3.5 Switch-on delay

2 s

11.4 Performance characteristics

11.4.1 Reference operating conditions

Adjustment temperature (ice bath)	0 °C (32 °F) for sensor
Ambient temperature range	25 °C ± 3 °C (77 °F ± 5 °F) for electronics
Supply voltage	24 V _{DC} ± 10 %
Relative humidity	< 95 %

11.4.2 Maximum measured error

According to DIN EN 60770 and the reference conditions specified above. The measured error data correspond to $\pm 2 \sigma$ (Gaussian distribution). The data include non-linearities and repeatability.



$|T|$ = Numerical value of the temperature in °C without regard to algebraic sign.

Thermometer without electronics

Standard	Designation	Measuring range	Measured error ME (\pm)	
			Maximum ¹⁾	Based on measured value ²⁾
IEC 60751	Pt100 Cl. A	-50 to +200 °C (-58 to +392 °F)	0.55 K (0.99 °F)	ME = $\pm (0.15 \text{ K (0.27 °F)} + 0.002 * T)$

- 1) Maximum measured error for the specified measuring range.
- 2) Deviations from maximum measured error possible due to rounding.

Thermometer with electronics

Standard	Designation	Measuring range	Measured error (\pm) ¹⁾
IEC 60751	Pt100 Cl. A	-50 to +200 °C (-58 to +392 °F)	0.1 K (0.18 °F) or 0.08 %

- 1) Percentage refers to the set span. The larger value is valid.

Total measured error of thermometer (sensor + electronics)

Standard	Designation	Measuring range	Measured error ME (\pm) ¹⁾
IEC 60751	Pt100 Cl. A	<ul style="list-style-type: none"> ■ -50 to +150 °C (-58 to +302 °F) without extension neck ■ -50 to +200 °C (-58 to +392 °F) with extension neck 	ME = $\pm (0.25 \text{ K (0.48 °F)} + 0.002 * T)$

- 1) Deviations from maximum measured error possible due to rounding.

11.4.3 Long-term drift

Electronics:

$\leq 0.1 \text{ K (0.18 °F)}/\text{year}$ or $0.05 \text{ %}/\text{year}$

Data under reference operating conditions. % refers to the set span. The larger value is valid.

11.4.4 Operating influences

The measured error data correspond to $\pm 2 \sigma$ (Gaussian distribution).

Ambient temperature	$T = \pm(15 \text{ ppm/K} * (\text{full scale value} + 200) + 50 \text{ ppm/K} * \text{set measuring range}) * DT$ DT = deviation of ambient temperature from the reference operating conditions
Supply voltage	$\leq \pm 0.01\%/V$ deviation from 24 V ¹⁾
Load	$\pm 0.02\%/100 \Omega$ ¹⁾

1) Specifications in percent refer to the full scale value of the measuring range

11.4.5 Sensor response time

Tests in water at 0.4 m/s (1.3 ft/s) according to IEC 60751; temperature changes in increments of 10 K. Response times measured for the version without electronics.

t_{50}	t_{90}
< 1 s	< 2 s

11.4.6 Electronics response time

Max. 1 s

 When recording step responses, it is important to bear in mind that the response times of the sensor might be added to the specified times.

11.4.7 Sensor current

$\leq 0.6 \text{ mA}$

11.5 Environment

11.5.1 Ambient temperature range

T_a	-40 to +85 °C (-40 to +185 °F)
-------	--------------------------------

11.5.2 Storage temperature

 Pack the device so that it is reliably protected against impact when it is stored (and transported). The original packaging offers the best protection.

T_s	-40 to +85 °C (-40 to +185 °F)
-------	--------------------------------

11.5.3 Operating altitude

Up to 2 000 m (6 600 ft) above sea level

11.5.4 Climate class

In accordance with IEC/EN 60654-1, class C

11.5.5 Degree of protection

As per IEC/EN 60529: IP67 with coupling and connecting cable (not evaluated by UL).
Depends on the degree of protection of the connection cable. →  20

11.5.6 Shock and vibration resistance

4g in the range from 2 to 150 Hz as per DIN EN 60068-2-6

11.5.7 Electromagnetic compatibility (EMC)

EMC to all relevant requirements of the IEC/EN 61326-series and NAMUR Recommendation EMC (NE21). For details, refer to the Declaration of Conformity.

Maximum fluctuations during EMC-tests: < 1 % of measuring span.

Interference immunity to IEC/EN 61326-series, requirements for industrial areas

Interference emission to IEC/EN 61326-series, electrical equipment Class B

11.5.8 Electrical safety

- Protection class III
- Overvoltage category II
- Pollution level 2

11.6 Process

11.6.1 Process temperature range

The thermometer electronics must be protected against temperatures over 85 °C (185 °F) by an extension neck of the appropriate length.

Device version without electronics

Independent of the extension neck	-50 to +200 °C (-58 to +392 °F)
-----------------------------------	---------------------------------

Device version with electronics

Without extension neck	-50 to +150 °C (-58 to +302 °F)
With extension neck	-50 to +200 °C (-58 to +392 °F)

The following restrictions apply for the thermometer for general applications with a process connection, depending on the process connection and ambient temperature:

- If mounting with process connections with an adjustable insertion length, e.g. compression fitting with sealing taper, a corresponding extension neck length must be taken into consideration when installing. →  17
- Ambient temperatures must be taken into consideration

Maximum ambient temperature	Maximum process temperature	
	Without extension neck	With extension neck length 35 mm (1.38 in)
≤ 25 °C (77 °F)	150 °C (302 °F)	200 °C (392 °F)
≤ 40 °C (104 °F)	135 °C (275 °F)	180 °C (356 °F)
≤ 60 °C (140 °F)	120 °C (248 °F)	160 °C (320 °F)
≤ 85 °C (185 °F)	100 °C (212 °F)	133 °C (271 °F)

11.6.2 Process pressure range

The maximum possible process pressure depends on various influencing factors, such as the design, process connection and process temperature. Maximum possible process pressures for the individual process connections. → 31

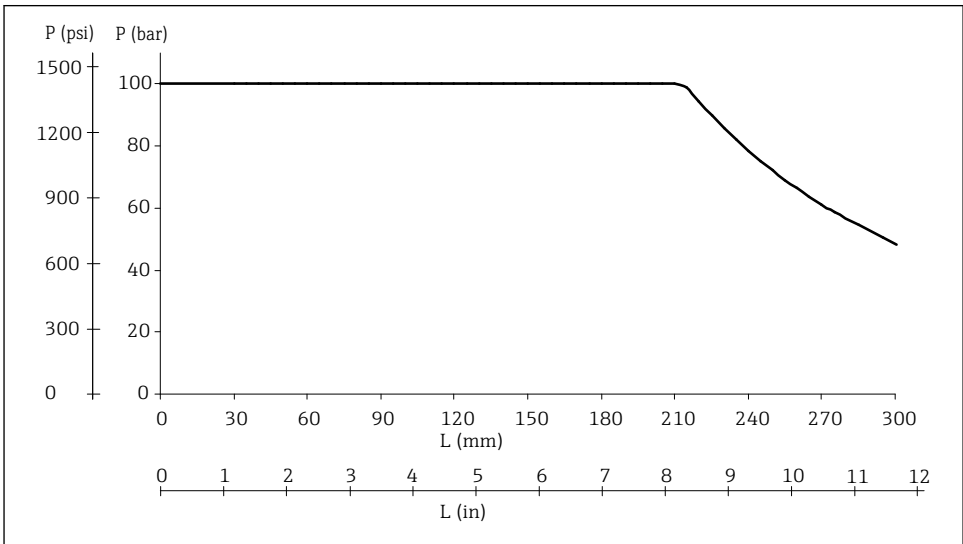

A0008063

5 Maximum permitted process pressure

- L* Insertion length
- p* Process pressure

The diagram not only considers the overpressure but also the pressure load caused by the flow, wherein a safety factor of 1.9 has been specified for operation with flow. The maximum permitted static operating pressure is lower for longer insertion lengths due to the increased bending load caused by the flow. The calculation assumes the maximum permitted flow velocity for the respective insertion length (see the diagram below).

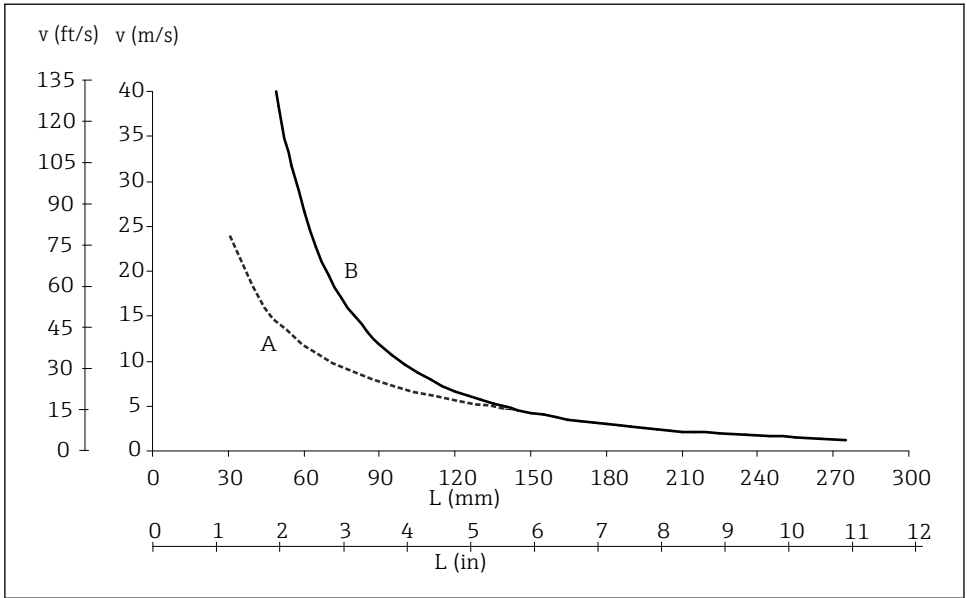

A0008065

6 Permitted flow velocity depending on the insertion length

L Insertion length during flow

v Flow velocity

A Medium: water at $T = 50\text{ }^{\circ}\text{C}$ ($122\text{ }^{\circ}\text{F}$)

B Medium: superheated steam at $T = 200\text{ }^{\circ}\text{C}$ ($392\text{ }^{\circ}\text{F}$)

The permitted flow velocity is the minimum from the resonance velocity (resonance distance 80%) and the load or buckling caused by flow, which would result in the failure of the thermometer tube or the undershooting of the safety factor (1.9). The calculation was performed for the specified limit operating conditions of $T = 200\text{ }^{\circ}\text{C}$ ($392\text{ }^{\circ}\text{F}$) and process pressure $p \leq 100\text{ bar}$ (1450 psi).

11.6.3 Medium - state of aggregation

Gaseous or liquid (also with high viscosity, e.g. yogurt).

11.7 Mechanical construction

11.7.1 Design, dimensions

Thermometer for general applications

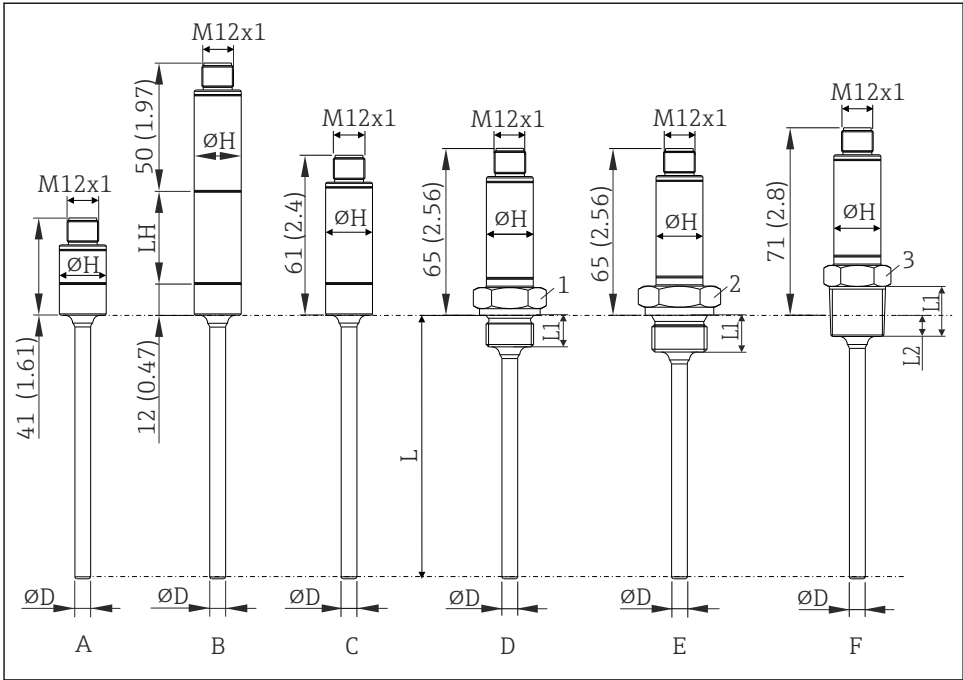

A0020192

7 Dimensions in mm (in)

L Insertion length L , variable 40 to 600 mm (1.6 to 23.6 in)

$\varnothing D$ Diameter D 6 mm (0.25 in)

$\varnothing H$ Sleeve diameter 18 mm (0.71 in)

Item	Version	Thread length L_1	Thread length L_2	P_{max}
A	Shortened sleeve (without built-in transmitter, without extension neck, without process connection). For suitable welding bosses and compression fittings, see the Accessories section.	-	-	-
B	With extension neck; L_H = Extension neck length 35 mm or 50 mm (1.38 in or 1.97 in), without process connection. For suitable welding bosses and compression fittings, see the Accessories section.	-	-	-
C	Without extension neck, without process connection. For suitable welding bosses and compression fittings, see the Accessories section.	-	-	-

Item	Version	Thread length L ₁	Thread length L ₂	P _{max.}
D	Without extension neck, metric threaded process connection: <ul style="list-style-type: none"> ▪ M14x1.5 (1 = SW/AF19) ▪ M18x1.5 (1 = SW/AF24) 	12 mm (0.47 in)	-	100 bar (1450 psi)
E	Without extension neck, threaded process connection, cylindrical as per ISO 228: <ul style="list-style-type: none"> ▪ G$\frac{1}{4}$" (2 = SW/AF19) ▪ G$\frac{1}{2}$" (2 = SW/AF27) 	12 mm (0.47 in) 14 mm (0.55 in)	- -	
F	Without extension neck, threaded process connection in inches, conical: <ul style="list-style-type: none"> ▪ ANSI NPT $\frac{1}{4}$" (3 = SW/AF19) ▪ ANSI NPT $\frac{1}{2}$" (3 = SW/AF27) ▪ BSPT R $\frac{1}{2}$" (3 = SW/AF/22) 	14.3 mm (0.56 in) 19 mm (0.75 in) 19 mm (0.75 in)	5.8 mm (0.23 in) 8.1 mm (0.32 in) 8.1 mm (0.32 in)	

11.7.2 Design, dimensions

Thermometer for hygienic applications

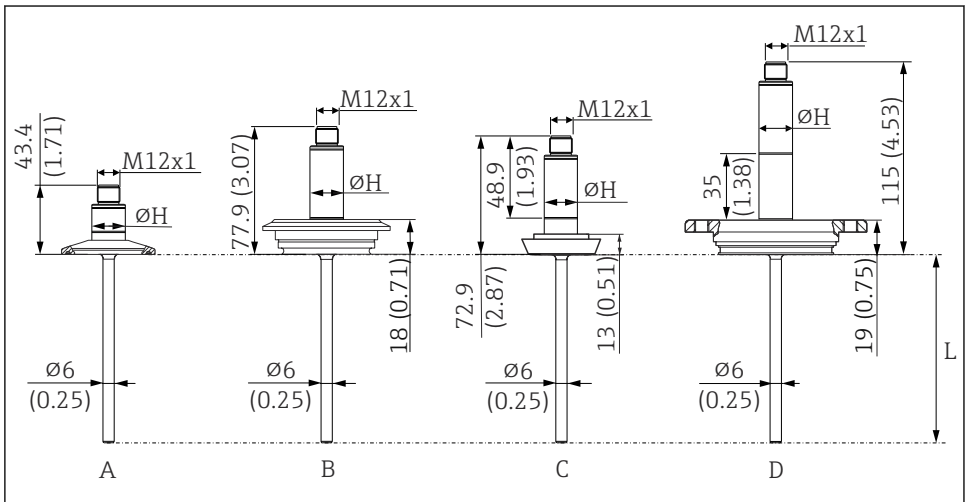

A0018283

8 Dimensions in mm (in)

L Insertion length *L*, variable 40 to 600 mm (1.6 to 23.6 in)

ØH Sleeve diameter 18 mm (0.71 in)

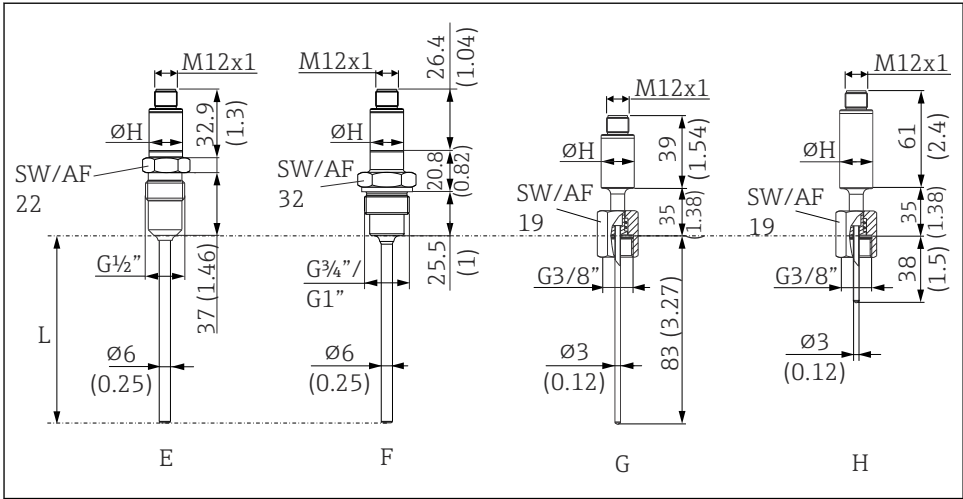

A0044938

9 Dimensions in mm (in)

L Insertion length L, variable 40 to 600 mm (1.6 to 23.6 in)

ØH Sleeve diameter 18 mm (0.71 in)

Item	Version
A	Shortened sleeve (without built-in transmitter, without extension neck), with 1" clamp process connection (example for minimum length)
B	Without extension neck, process connection Varivent F
C	Without extension neck, process connection according to DIN 11851
D	With extension neck 35 mm (1.38 in), with APV-INLINE process connection (example for maximum length)
E	Shortened sleeve (without built-in transmitter, without extension neck), process connection metal sealing system for hygienic processes, G½" thread. Suitable welding boss available as an accessory.
F	Shortened sleeve (without built-in transmitter, without extension neck), process connection for hygienic processes, G¾" or G1" thread, material 316L (1.4404).
G	Shortened sleeve (without built-in transmitter), with extension neck, insertion length 83 mm (3.27 in)
H	With extension neck, insertion length 38 mm (1.5 in)

11.7.3 Weight

0.2 to 2.5 kg (0.44 to 5.5 lbs) for standard versions

11.7.4 Material

The temperatures for continuous operation specified in the following table are only intended as reference values for use of the various materials in air and without any significant

compressive load. The maximum operating temperatures can be reduced considerably in cases where abnormal conditions such as high mechanical load occur or in aggressive media.

Description	Short form	Recommended max. temperature for continuous use in air	Properties
AISI 316L (corresponds to 1.4404 or 1.4435)	X2CrNiMo17-13-2, X2CrNiMo18-14-3	650 °C (1 202 °F) ¹⁾	<ul style="list-style-type: none"> ■ Austenitic, stainless steel ■ High corrosion resistance in general ■ Particularly high corrosion resistance in chlorine-based and acidic, non-oxidizing atmospheres through the addition of molybdenum (e.g. phosphoric and sulfuric acids, acetic and tartaric acids with a low concentration) ■ Increased resistance to intergranular corrosion and pitting

- 1) Can be used to a limited extent up to 800 °C (1472 °F) for low compressive loads and in non-corrosive media. More information is available from the sales organization.

11.7.5 Surface roughness

Values for wetted surfaces:

Standard surface, mechanically polished ¹⁾	$R_a \leq 0.76 \mu\text{m}$ (30 μin)
Mechanically polished ¹⁾ , buffed ²⁾	$R_a \leq 0.38 \mu\text{m}$ (15 μin)
Mechanically polished ¹⁾ , buffed and electropolished	$R_a \leq 0.38 \mu\text{m}$ (15 μin)+ electropolished

- 1) Or equivalent treatment that guarantees R_a max
 2) Not compliant with ASME BPE

11.7.6 Process connections for hygienic applications

All dimensions in mm (in).

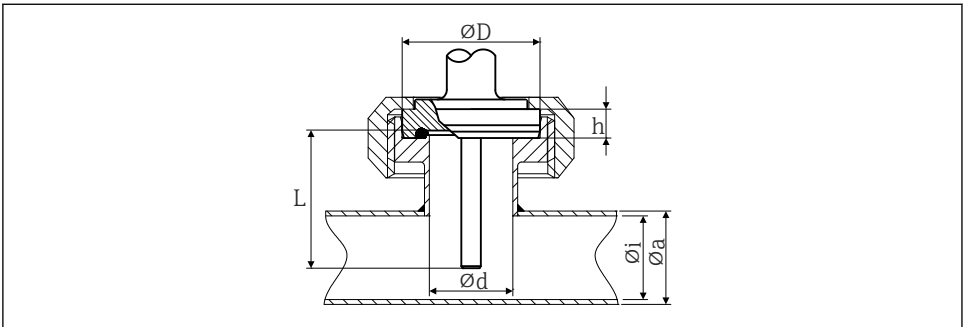

A0045089

10 Aseptic pipe union according to DIN 11864-1, Form A

Version	Dimensions					Technical properties
	ϕd	ϕD	ϕi	ϕa	h	
DN25	26 mm (1.02 in)	42.9 mm (1.7 in)	26 mm (1.02 in)	29 mm (1.14 in)	9 mm (0.35 in)	<ul style="list-style-type: none"> ■ $P_{max} = 40$ bar (580 psi) ■ 3-A® marked and EHEDG certified ■ ASME BPE compliance

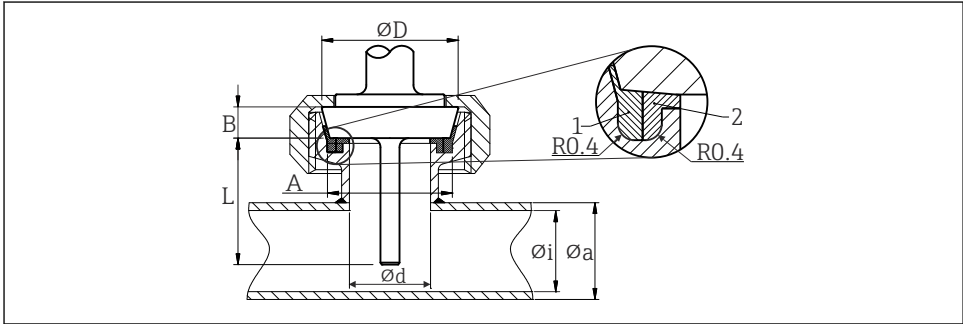

A0045090

11 Milk pipe connection according to DIN 11851

- 1 Centering ring
- 2 Sealing ring

- 3-A® marked and EHEDG certified (only with EHEDG-certified and self-centering sealing ring).
- ASME BPE compliance

Version ¹⁾	Type					Technical properties
	Dimensions					
	ϕD	A	B	ϕi	ϕa	P_{max}
DN25	44 mm (1.73 in)	30 mm (1.18 in)	10 mm (0.39 in)	26 mm (1.02 in)	29 mm (1.14 in)	40 bar (580 psi)
DN40	56 mm (2.2 in)	42 mm (1.65 in)	10 mm (0.39 in)	38 mm (1.5 in)	41 mm (1.61 in)	40 bar (580 psi)
DN50	68 mm (2.68 in)	54 mm (2.13 in)	11 mm (0.43 in)	50 mm (1.97 in)	53 mm (2.1 in)	25 bar (363 psi)

1) Pipes in accordance with DIN 11850

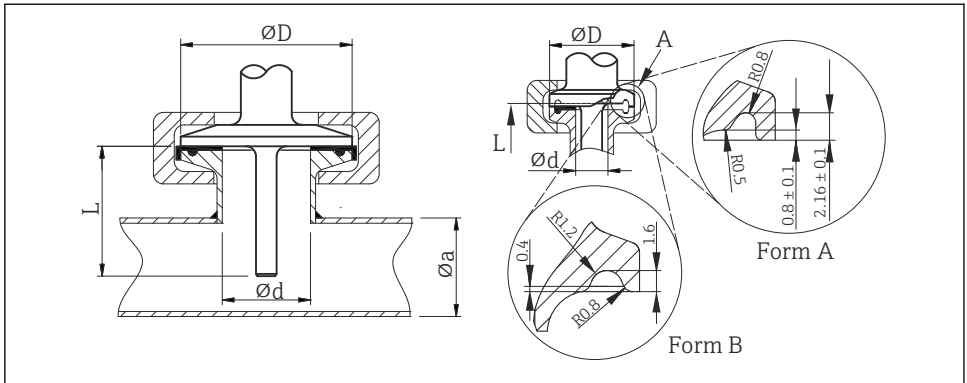

A0045091

12 Clamp according to ISO 2852

A Form A: in compliance with ASME BPE Type A and Form B: in compliance with ASME BPE Type B and ISO 2852

Version	Dimensions		Technical properties	Conformity
	ϕd : ¹⁾	ϕD		
Microclamp ²⁾ DN8-18 (0.5"-0.75") ³⁾ , Form A	25 mm (0.98 in)	-	<ul style="list-style-type: none"> ■ $P_{max.} = 16$ bar (232 psi), depends on clamp ring and suitable seal ■ 3-A[®] marked 	ASME BPE Type A
Clamp DN25-38 (1"-1.5"), Form B	50.5 mm (1.99 in)	29 to 42.4 mm (1.14 to 1.67 in)	<ul style="list-style-type: none"> ■ $P_{max.} = 16$ bar (232 psi), depends on clamp ring and suitable seal ■ 3-A[®] marked and EHEDG certified (combined with Combifit seal) ■ Can be used with "Novaseptic Connect (NA Connect)" which enables flush-mount installation 	ASME BPE Type B; ISO 2852
Clamp DN40-51 (2"), Form B	64 mm (2.52 in)	44.8 to 55.8 mm (1.76 to 2.2 in)		ASME BPE Type B; ISO 2852
Clamp DN63,5 (2.5"), Form B	77.5 mm (3.05 in)	68.9 to 75.8 mm (2.71 to 2.98 in)		ASME BPE Type B; ISO 2852

- 1) Pipes in accordance with ISO 2037 and BS 4825 Part 1
- 2) Microclamp (not in ISO 2852); no standard pipes
- 3) DN8 (0.5") only possible with thermowell diameter = 6 mm (¼ in)

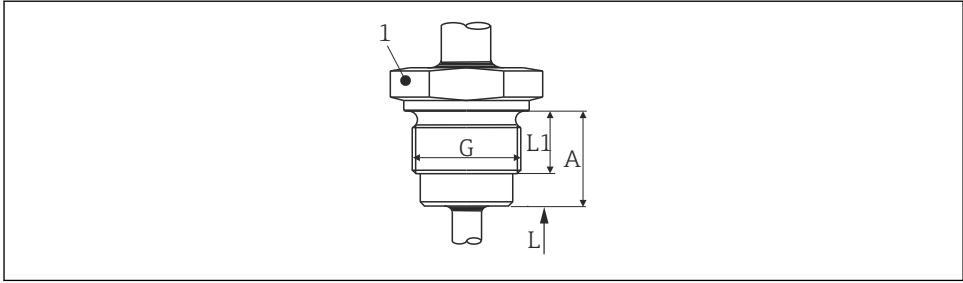

A0045092

13 Thread according to ISO 228 for weld-in adapter

Version G	Dimensions			Technical properties
	L1 thread length	A	1 (SW/AF)	
G $\frac{3}{4}$ "	16 mm (0.63 in)	25.5 mm (1 in)	32	<ul style="list-style-type: none"> ■ P_{max.} = 25 bar (362 psi) at max. 150 °C (302 °F) ■ P_{max.} = 40 bar (580 psi) at max. 100 °C (212 °F) ■ ASME BPE compliance
G $\frac{3}{4}$ "				
G1"	18.6 mm (0.73 in)	29.5 mm (1.16 in)	41	

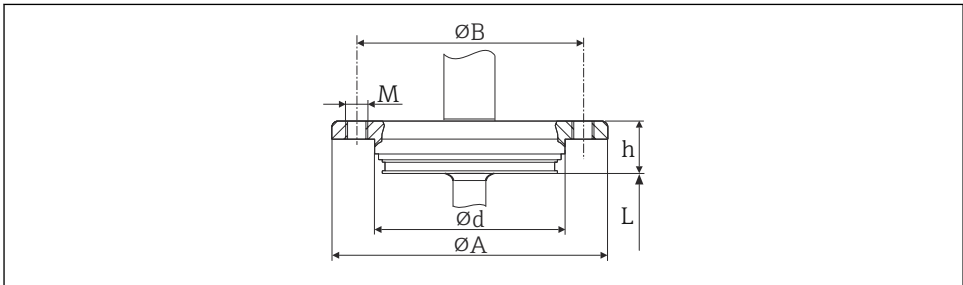

A0045093

14 APV Inline

Version	Dimensions					Technical properties
	ød	øA	øB	M	h	
DN50	69 mm (2.72 in)	99.5 mm (3.92 in)	82 mm (3.23 in)	2xM8	19 mm (0.75 in)	<ul style="list-style-type: none"> ■ P_{max.} = 25 bar (362 psi) ■ 3-A® marked and EHEDG certified ■ ASME BPE compliance

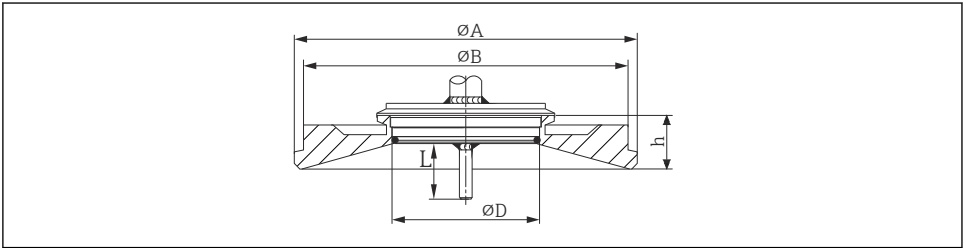

A0045094

15 Varivent®

Version	Dimensions				Technical properties	
	ϕD	ϕA	ϕB	h	$P_{max.}$	
Type F	50 mm (1.97 in)	145 mm (5.71 in)	135 mm (5.31 in)	24 mm (0.95 in)	10 bar (145 psi)	<ul style="list-style-type: none"> 3-A® marked and EHEDG certified ASME BPE compliance
Type N	68 mm (2.67 in)	165 mm (6.5 in)	155 mm (6.1 in)	24.5 mm (0.96 in)		

i The VARINLINE® housing connection flange is suitable for weld-in into the conical or torispherical head in tanks or vessels with a small diameter (≤ 1.6 m (5.25 ft)) and up to a wall thickness of 8 mm (0.31 in).

Varivent® Type F cannot be used for installations in pipes in combination with the VARINLINE® housing connection flange.

Type	Version	Technical properties
<p>Metal sealing system</p> <p>G½"</p> <p>A technical drawing of a metal sealing system. It shows a cylindrical component with a conical end. Dimensions are labeled: $\phi 18$ (0.71) is the diameter of the conical part; $\phi 6$ (1/4) is the diameter of the main body; 14 (0.55) is the length of the conical part; 8 (0.31) is the thickness of the main body; 22.5° is the angle of the conical part; G3/8" is the thread size of the main body; L is the length of the main body; 37 (1.46) is the length of the conical part; and T = 60 (2.36) is the total length.</p>	<p>Thermowell diameter 6 mm (¼ in)</p>	<p>$P_{max.} = 16$ bar (232 psi)</p> <p>i Maximum torque = 10 Nm (7.38 lbf ft)</p>

A0045095

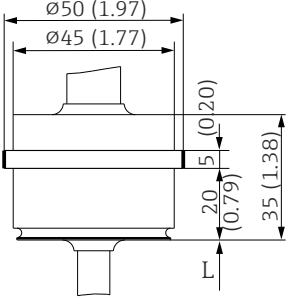
Type	Version	Technical properties
<p style="text-align: center;">Process adapter</p>  <p style="text-align: right; font-size: small;">A0045096</p>	<p>D45</p>	<p>-</p>

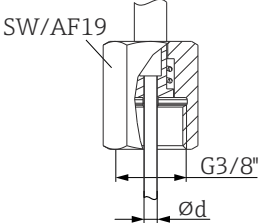
Type	Version	Technical properties
<p style="text-align: center;">Spring-loaded cap-nut</p>  <p style="text-align: right; font-size: small;">A0044937</p>	<p>G3/8" thread for mounting in a thermowell</p>	<p>-</p>

11.7.7 Thermowell design, dimensions

Thermometer for hygienic applications

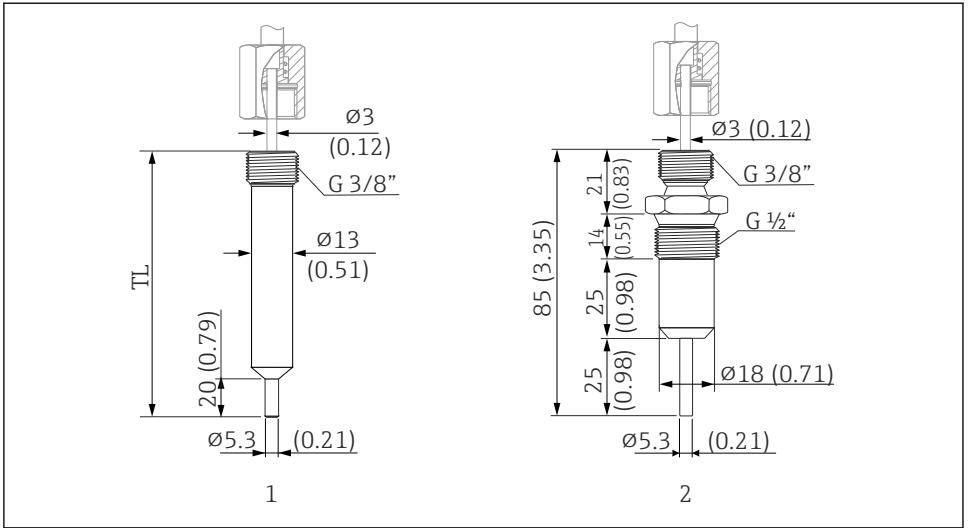

A0018305

16 Thermowell for connection to the compact thermometer with spring-loaded cap-nut and G3/8" thread. Dimensions in mm (in)

- 1 Cylindrical thermowell, TL = 70 mm (2.76 in), option WA or 85 mm (3.35 in), option WB, with 3-A[®] symbol, $P_{max.} = 250$ bar (3 626 psi) with maximum flow velocity of 40 m/s (131 ft/s)
- 2 Thermowell, metal-to-metal seal, $P_{max.} = 16$ bar (232 psi)

11.8 Certificates and approvals

11.8.1 CE mark

The product meets the requirements of the harmonized European standards. As such, it complies with the legal specifications of the EC directives. The manufacturer confirms successful testing of the product by affixing to it the CE-mark.

11.8.2 EAC mark

The product meets the legal requirements of the EEU guidelines. The manufacturer confirms the successful testing of the product by affixing the EAC mark.

11.8.3 Hygiene standard

- EHEDG certification, type EL CLASS I. EHEDG-certified/tested process connections. → 31
- 3-A Authorization No. 1144, 3-A Sanitary Standard 74-07. Listed process connections. → 31
- ASME BPE, declaration of conformity can be ordered for options indicated
- FDA-compliant
- All surfaces in contact with the medium are free from materials derived from bovine animals or other livestock (ADI/TSE)

11.8.4 Materials in contact with food/product (FCM)

The materials of the thermometer in contact with food/product (FCM) comply with the following European regulations:

- (EC) No. 1935/2004, Article 3, paragraph 1, Articles 5 and 17 on materials and articles intended to come into contact with food.
- (EC) No. 2023/2006 on good manufacturing practice for materials and articles intended to come into contact with food.
- (EU) No. 10/2011 on plastic materials and articles intended to come into contact with food.

11.8.5 Marine approval

Information on the Type Approval Certificates currently available (DNVGL, BV, etc.) can be obtained from the sales organization.

11.8.6 Other standards and guidelines

- IEC 60529:
Degrees of protection provided by enclosures (IP code)
- IEC/EN 61010-1:
Safety requirements for electrical equipment for measurement, control, and laboratory use
- IEC/EN 61326 series:
Electromagnetic compatibility (EMC requirements)

11.8.7 Material certification

The material certificate 3.1 (according to EN 10204) can be requested separately. The short form certificate includes a simplified declaration with no enclosures of documents related to the materials used in the design of the individual sensor, but guarantees the traceability of the materials through the identification number of the thermometer. The data regarding the origin of the materials can subsequently be requested by the client if necessary.

11.8.8 Calibration

The factory calibration is performed according to an internal procedure in a laboratory of the manufacturer that is accredited by the European Accreditation Organization (EA) according to ISO/IEC 17025. A calibration which is performed according to EA guidelines (SIT/Accredia or DKD/DAkKs) can be requested separately. The calibration is performed on the replaceable insert of the thermometer. In the case of thermometers without a replaceable insert, the entire thermometer - from the process connection to the tip of the thermometer - is calibrated.

11.8.9 UL approval

More information under UL Product iq™, search for keyword "E225237")



71602345