



## Brief Operating Instructions RN42

1-channel active barrier with 24 to 230 V<sub>AC/DC</sub> wide range power supply for the safe separation of 0/4 to 20 mA standard signal circuits, HART-transparent

These Brief Operating Instructions are not a substitute for the Operating Instructions pertaining to the device.

Detailed information is provided in the Operating Instructions and other documentation.

Available for all device versions via:

- Internet: [www.endress.com/deviceviewer](http://www.endress.com/deviceviewer)
- Smartphone/tablet: Endress+Hauser Operations app

### Basic safety instructions

#### Requirements for the personnel

The personnel must fulfill the following requirements for its tasks:

- ▶ Trained, qualified specialists must have a relevant qualification for this specific function and task.
- ▶ Are authorized by the plant owner/operator.
- ▶ Are familiar with federal/national regulations.
- ▶ Before starting work, read and understand the instructions in the manual and supplementary documentation as well as the certificates (depending on the application).
- ▶ Follow instructions and comply with basic conditions.

#### Intended use

The active barrier is used for the safe isolation of 0/4 to 20 mA standard signal circuits. An intrinsically safe version is optionally available for operation in Zone 2. The device is designed for installation on DIN rails in accordance with IEC 60715.

**Product liability:** The manufacturer does not accept any responsibility for damage that results from non-designated use and from failure to comply with the instructions in this manual.

#### Operational safety

Risk of injury!

- ▶ Operate the device only if it is in proper technical condition, free from errors and faults.
- ▶ The operator is responsible for interference-free operation of the device.

### Incoming acceptance and product identification

#### Incoming acceptance

Check the following during incoming acceptance:

- Are the order codes on the delivery note and the product sticker identical?
- Are the goods undamaged?
- Do the data on the nameplate match the ordering information on the delivery note?



If one of these conditions is not met, please contact the manufacturer's sales office.

#### Product identification

The following options are available for identification of the device:

- Nameplate specifications
- Extended order code with breakdown of the device features on the delivery note

*Name and address of manufacturer*

#### Hazardous area

To eliminate danger to persons or the facility when the device is used in the hazardous area (e.g. explosion protection):

- ▶ Check the nameplate to verify if the device ordered can be put to its intended use in the hazardous area.
- ▶ Observe the specifications in the separate supplementary documentation that is an integral part of these instructions.

#### Product safety

This device is designed in accordance with good engineering practice to meet state-of-the-art safety requirements, has been tested, and left the factory in a condition in which it is safe to operate.

#### Installation instructions

- The device's IP20 degree of protection is intended for a clean and dry environment.
- Do not expose the device to mechanical and/or thermal stress that exceeds the specified limits.
- The device is intended for installation in a cabinet or similar housing. The device may only be operated as an installed device.
- To protect against mechanical or electrical damage, the device must be installed in an appropriate housing with a suitable degree of protection according to IEC/EN 60529.
- The device fulfills the EMC regulations for the industrial sector.

<b>Name of manufacturer:</b>	Endress+Hauser Wetzler GmbH + Co. KG
<b>Address of manufacturer:</b>	Obere Wank 1, D-87484 Nesselwang
<b>Model/type reference:</b>	RN42

#### Certificates and approvals



For certificates and approvals valid for the device: see the data on the nameplate



Approval-related data and documents: [www.endress.com/deviceviewer](http://www.endress.com/deviceviewer) → (enter the serial number)

**Functional safety**

A SIL version of the device is optionally available. It can be used in safety equipment in accordance with IEC 61508 up to SIL 2 (SC 3) .

**Mounting**

**Mounting requirements**

*Dimensions*

Width (B) x length (L) x height (H) (with terminals): 17.5 mm (0.69 in) x 116 mm (4.57 in) x 107.5 mm (4.23 in)

*Mounting location*

The device is designed for installation on 35 mm (1.38 in) DIN rails in accordance with IEC 60715 (TH35).

**NOTICE**

- ▶ When using in hazardous areas, the limit values of the certificates and approvals must be observed.

**Important ambient conditions**

Ambient temperature range	-40 to 60 °C (-40 to 140 °F)	Storage temperature	-40 to 80 °C (-40 to 176 °F)
---------------------------	------------------------------	---------------------	------------------------------

**Electrical connection**

**Connecting requirements**

A flat-blade screwdriver is required to establish an electrical connection to screw or push-in terminals.

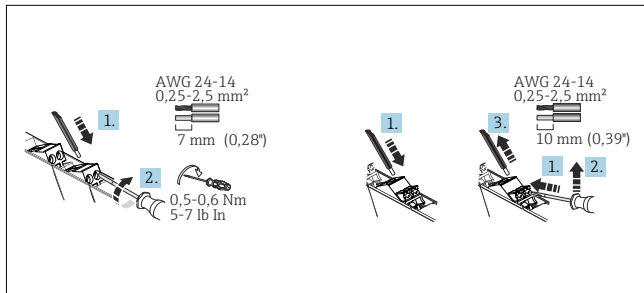

1 Electrical connection using screw terminals (left) and push-in terminals (right)

**CAUTION**

**Destruction of parts of the electronics**

- ▶ Switch off the power supply before installing and connecting the device.

**NOTICE**

**Destruction or malfunction of parts of the electronics**

- ▶ ⚠ ESD - Electrostatic discharge. Protect the terminals and HART sockets on the front from electrostatic discharge.
- ▶ A shielded cable is recommended for HART communication. Observe grounding concept of the plant.

**i** Only use copper cables with a minimum temperature rating of 75 °C (167 °F) as the connecting cables.

**Special connection instructions**

- Disconnecting devices and auxiliary circuit protective systems with suitable AC or DC values must be provided within reach in the building installation.
- A switch/power circuit breaker must be provided close to the device and clearly marked as a disconnecting unit for this device.
- A circuit breaker (nominal current ≤ 10 A; break capacity 6 kA; e.g. type B) must be available within reach for the supply line.

**Important connection data**

*Performance characteristics*



Please refer to Safety Manual FY01034K for the use of the device in safety instrumented systems according to IEC 61508.

Degree of protection	IP 20	Overvoltage category	II
Pollution degree	2	Humidity	5 to 95 %
Operating altitude, hazardous area version	≤ 2 000 m (6 562 ft)	Operating altitude, non-hazardous area version	≤ 4 000 m (13 123 ft)
		Insulation class	Class II

**Installing a DIN rail device**

The device can be installed in any position (horizontal or vertical) on the DIN rail without lateral clearance from neighboring devices. No tools are required for installation. The use of end brackets (type WEW "35/1" or similar) on the DIN rail is recommended as an end support for the device.



When installing several devices side by side, it is important to ensure that the maximum side wall temperature of 80 °C (176 °F) of the individual devices is not exceeded. If this cannot be guaranteed, mount the devices at a distance from one another or ensure sufficient cooling.

*Power supply*<sup>1)</sup>

Supply voltage	24 to 230 V <sub>AC/DC</sub> (-20% / +10%, 0/50/60 Hz)
Power consumption	≤ 4.9 VA / 2.4 W (20 mA); ≤ 5 VA / 2.5 W (22 mA)
Power loss	≤ 2 W (20 mA); ≤ 2.1 W (22 mA)
Current consumption at 24 V <sub>DC</sub>	≤ 0.1 A (20 mA); ≤ 0.1 A (22 mA)
Current consumption at 230 V <sub>AC</sub>	≤ 0.02 A (20 mA); ≤ 0.02 A (22 mA)

1) The data apply for the following operating scenario: input active / output active / output load 0 Ω. When external voltages are connected to the output, the power loss in the device may increase. The power loss in the device can be reduced by connecting an external output load.

*Input data*

Input signal range (underrange / overrange)	0 to 22 mA
Function range, input signal	0/4 to 20 mA
Transmitter supply voltage	≥ 16.5 V / (20 mA)

*Output data*

Output signal range (underrange / overrange)	0 to 22 mA
Function range, output signal	0/4 to 20 mA
Transmission behavior	1:1 to input signal
Step response (10 to 90 %)	≤ 1 ms
Load	≤ 500 Ω (for active mode)
Transmissible communication protocols	HART

*Accuracies*

Transmission error max. (0 to 20.5 mA)	< 0.1 % / of full scale value (< 20 μA)
Temperature coefficient	< 0.01 % /K

Galvanic isolation

Power supply to input/output	Testing voltage: 3 000 V <sub>AC</sub> 50 Hz, 1 min
Input to output	Testing voltage: 1 500 V <sub>AC</sub> 50 Hz, 1 min

 For detailed technical data, see the Operating Instructions

Quick wiring guide

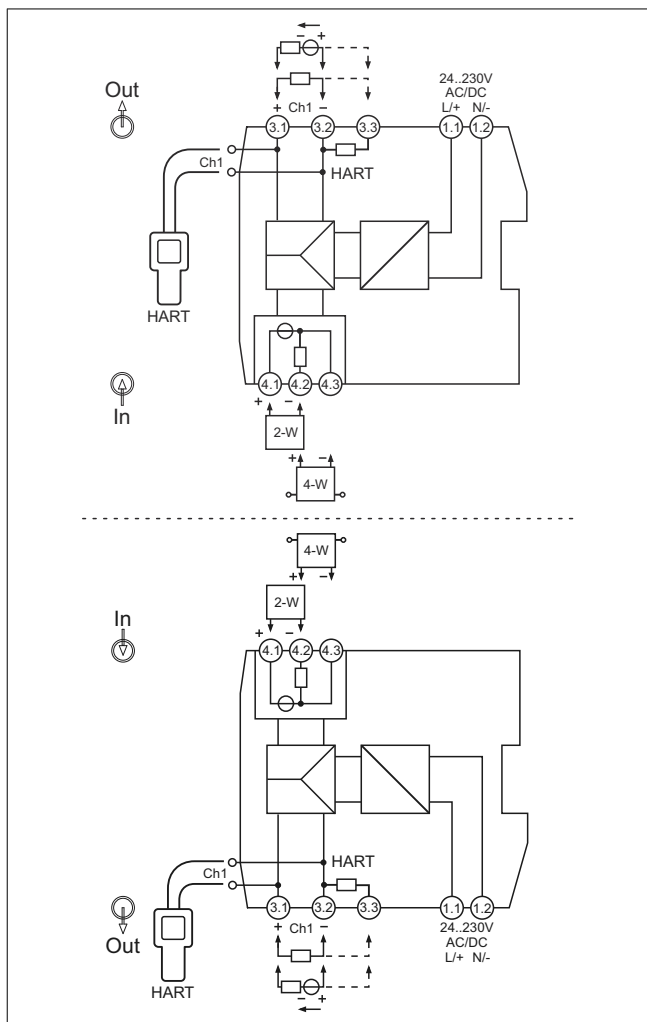

 2 Terminal assignment, top: power supply top; bottom: power supply bottom (option)

 HART communicators can be connected to the HART connection sockets. Ensure that there is an adequate external load ( $\geq 230 \Omega$ ) in the output circuit. If the external load is not sufficient, an internal 250  $\Omega$  communication resistor can be added to the measuring loop via the alternative terminal assignment (terminal 3.3.) to use the HART connection sockets.

Connecting the supply voltage

The power is supplied via terminals 1.1 and 1.2.

Display and operating elements

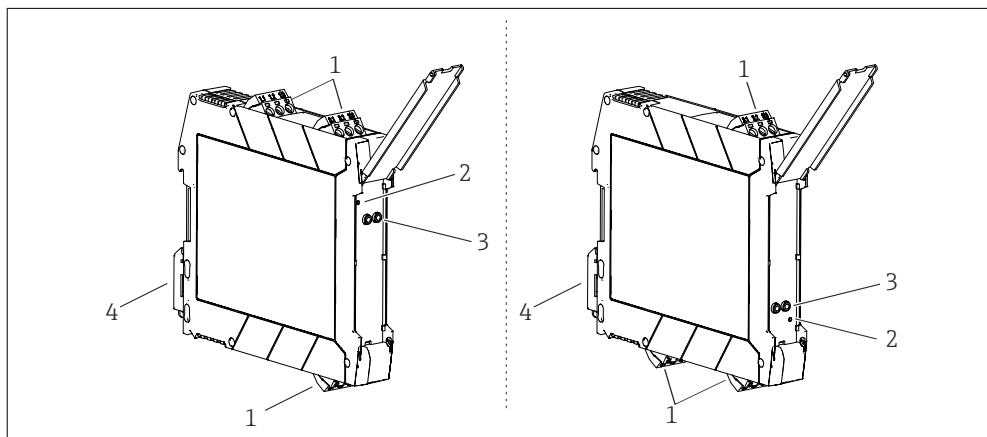

 3 Display and operating elements, left: power supply top; right: power supply bottom (option)

- 1 Plug-in screw or push-in terminal
- 2 Green LED "On", power supply
- 3 Connection sockets for HART communication (channel 1)
- 4 DIN rail clip for DIN rail mounting

## Local operation

### *Hardware settings / configuration*

No manual hardware settings are required at the device for commissioning.

Attention must be paid to the different terminal assignment when connecting 2/4-wire transmitters. At the output side, the connected system is detected and automatic switching takes place between the active and passive mode.

## Maintenance

No special maintenance work is required for the device.

### **Cleaning**

A clean, dry cloth can be used to clean the device.