



# Brief Operating Instructions

## Active barrier 24 VDC

1- or 2-channel 24 V<sub>DC</sub> active barrier for safe separation of 4 to 20 mA standard signal circuits, optionally available as a signal doubler, HART-transparent

These Instructions are Brief Operating Instructions; they do not replace the Operating Instructions included in the scope of supply. Please refer to the Operating Instructions and other documentation provided by your supplier for detailed information.

### Basic safety instructions

#### Requirements for the personnel

The personnel must fulfill the following requirements for its tasks:

- ▶ Trained, qualified specialists must have a relevant qualification for this specific function and task.
- ▶ Are authorized by the plant owner/operator.
- ▶ Are familiar with federal/national regulations.
- ▶ Before starting work, read and understand the instructions in the manual and supplementary documentation as well as the certificates (depending on the application).
- ▶ Follow instructions and comply with basic conditions.

#### Intended use

The active barrier is used for the safe isolation of 0/4 to 20 mA standard signal circuits. An intrinsically safe version is optionally available for operation in Zone 2. The device is designed for installation on DIN rails in accordance with IEC 60715.

**Product liability:** The manufacturer does not accept any responsibility for damage that results from non-designated use and from failure to comply with the instructions in this manual.

#### Operational safety

Risk of injury!

- ▶ Operate the device only if it is in proper technical condition, free from errors and faults.
- ▶ The operator is responsible for interference-free operation of the device.

### Incoming acceptance and product identification

#### Incoming acceptance

Check the following during incoming acceptance:

- Are the order codes on the delivery note and the product sticker identical?
- Are the goods undamaged?
- Do the data on the nameplate match the ordering information on the delivery note?



If one of these conditions is not met, please contact the manufacturer's sales office.

#### Product identification

The following options are available for identification of the device:

- Nameplate specifications
- Extended order code with breakdown of the device features on the delivery note

*Name and address of manufacturer*

#### Hazardous area

To eliminate danger to persons or the facility when the device is used in the hazardous area (e.g. explosion protection):

- ▶ Check the nameplate to verify if the device ordered can be put to its intended use in the hazardous area.
- ▶ Observe the specifications in the separate supplementary documentation that is an integral part of these instructions.

#### Product safety

This device is designed in accordance with good engineering practice to meet state-of-the-art safety requirements, has been tested, and left the factory in a condition in which it is safe to operate.

#### Installation instructions

- The device's IP20 degree of protection is intended for a clean and dry environment.
- Do not expose the device to mechanical and/or thermal stress that exceeds the specified limits.
- The device is intended for installation in a cabinet or similar housing. The device may only be operated as an installed device.
- To protect against mechanical or electrical damage, the device must be installed in an appropriate housing with a suitable degree of protection according to IEC/EN 60529.
- The device fulfills the EMC regulations for the industrial sector.
- NE 21: Electromagnetic compatibility (EMC) of industrial process and laboratory control equipment is met under the following condition: power failures of up to 20 ms must be bridged with a suitable power supply.

<b>Name of manufacturer:</b>	Endress+Hauser Wetzler GmbH + Co. KG
<b>Address of manufacturer:</b>	Obere Wank 1, D-87484 Nesselwang
<b>Model/type reference:</b>	RN22

#### Certificates and approvals



For certificates and approvals valid for the device: see the data on the nameplate

#### Functional safety

A SIL version of the device is optionally available. It can be used in safety equipment in accordance with IEC 61508 up to SIL 2 (SC 3) .



Please refer to Safety Manual FY01034K for the use of the device in safety instrumented systems according to IEC 61508.

## Mounting

### Mounting requirements

#### Dimensions

Width (B) x length (L) x height (H) (with terminals): 12.5 mm (0.49 in) x 116 mm (4.57 in) x 107.5 mm (4.23 in)

#### Mounting location

The device is designed for installation on 35 mm (1.38 in) DIN rails in accordance with IEC 60715 (TH35).

#### NOTICE

- ▶ When using in hazardous areas, the limit values of the certificates and approvals must be observed.

### Important ambient conditions

Ambient temperature range	-40 to 60 °C (-40 to 140 °F)	Storage temperature	-40 to 80 °C (-40 to 176 °F)
Degree of protection	IP 20	Overvoltage category	II
Pollution degree	2	Humidity	5 to 95 %
Altitude	≤ 2 000 m (6 562 ft)	Insulation class	Class III

### Mounting the DIN rail bus connector

**i** If using the DIN rail bus connector to the power supply, clip it onto the DIN rail BEFORE mounting the device. It is essential that you pay attention to the orientation of the module and the DIN rail bus connector: the snap-on clip should be at the bottom and the connector piece on the left.

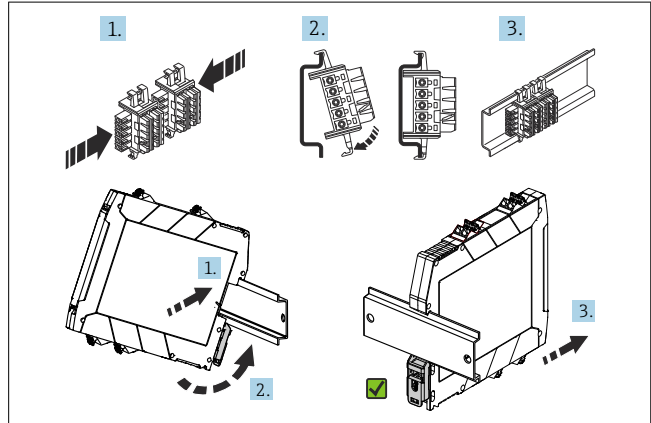

1 Mounting the DIN rail bus connector 12,5 mm (0,5 in) (top) and mounting on DIN rail (bottom)

### Installing a DIN rail device

The device can be installed in any position (horizontal or vertical) on the DIN rail without lateral clearance from neighboring devices. No tools are required for installation. The use of end brackets (type WEW "35/1" or similar) on the DIN rail is recommended as an end support for the device.

**i** When installing several devices side by side, it is important to ensure that the maximum side wall temperature of 80 °C (176 °F) of the individual devices is not exceeded. If this cannot be guaranteed, mount the devices at a distance from one another or ensure sufficient cooling.

## Electrical connection

### Connecting requirements

A flat-blade screw driver is required to establish an electrical connection to screw or push-in terminals.

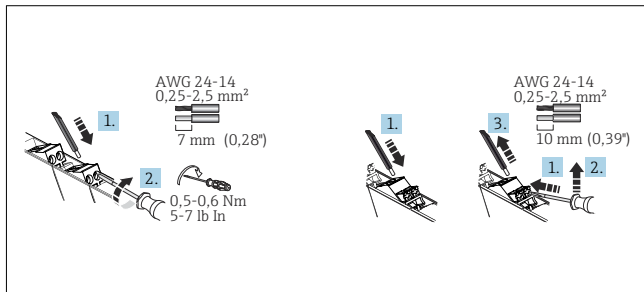

2 Electrical connection using screw terminals (left) and push-in terminals (right)

#### CAUTION

#### Destruction of parts of the electronics

- ▶ Switch off the power supply before installing and connecting the device.

#### NOTICE

#### Destruction or malfunction of parts of the electronics

- ▶ **ESD** - electrostatic discharge. Protect the terminals and HART lugs on the front from electrostatic discharge.
- ▶ A shielded cable is recommended for HART communication. Observe grounding concept of the plant.

**i** Only use copper cables with a minimum temperature rating of 75 °C (167 °F) as the connection cable.

### Important connection data

#### Performance characteristics

#### Power supply <sup>1)</sup>

Supply voltage	24 V <sub>DC</sub> (-20% / +25%)
Supply current to the DIN rail bus connector	max. 400 mA
Power consumption at 24 V <sub>DC</sub>	1-channel: ≤ 1.5 W (20 mA) / ≤ 1.6 W (22 mA) 2-channel: ≤ 3 W (20 mA) / ≤ 3.2 W (22 mA) Signal doubler: ≤ 2.4 W (20 mA) / ≤ 2.5 W (22 mA)
Current consumption at 24 V <sub>DC</sub>	1-channel: ≤ 0.07 A (20 mA) / ≤ 0.07 A (22 mA) 2-channel: ≤ 0.13 A (20 mA) / ≤ 0.14 A (22 mA) Signal doubler: ≤ 0.1 A (20 mA) / ≤ 0.11 A (22 mA)
Power loss at 24 V <sub>DC</sub>	1-channel: ≤ 1.2 W (20 mA) / ≤ 1.3 W (22 mA) 2-channel: ≤ 2.4 W (20 mA) / ≤ 2.5 W (22 mA) Signal doubler: ≤ 2.1 W (20 mA) / ≤ 2.2 W (22 mA)

- 1) The data apply for the following operating scenario: input active / output active / output load 0 Ω. When external voltages are connected to the output, the power loss in the device may increase. The power loss in the device can be reduced by connecting an external output load.

#### Input data

Input signal range (underrange / overrange)	0 to 22 mA
Function range, input signal	0/4 to 20 mA
Transmitter supply voltage	≥ 16.5 V / (20 mA)

#### Output data

Output signal range (underrange / overrange)	0 to 22 mA
Function range, output signal	0/4 to 20 mA
Transmission behavior	1:1 to input signal
Step response (10 to 90 %)	1 ms
Signal doubler output 2: signal delay due to HART filter	< 40 ms

Load	≤ 500 Ω (for active mode)
Transmissible communication protocols	HART

**Accuracies**

Transmission error max. (0 to 20.5 mA)	< 0.1 % / of full scale value (<20 μA)
Temperature coefficient	< 0.01 % /K

**Galvanic isolation**

Power supply / input; power supply / output Input / output; output / output	Testing voltage: 1500 V <sub>AC</sub> 50 Hz, 1 min
Input / input	Testing voltage: 500 V <sub>AC</sub> 50 Hz, 1 min

 For detailed technical data, see the Operating Instructions

**Quick wiring guide**

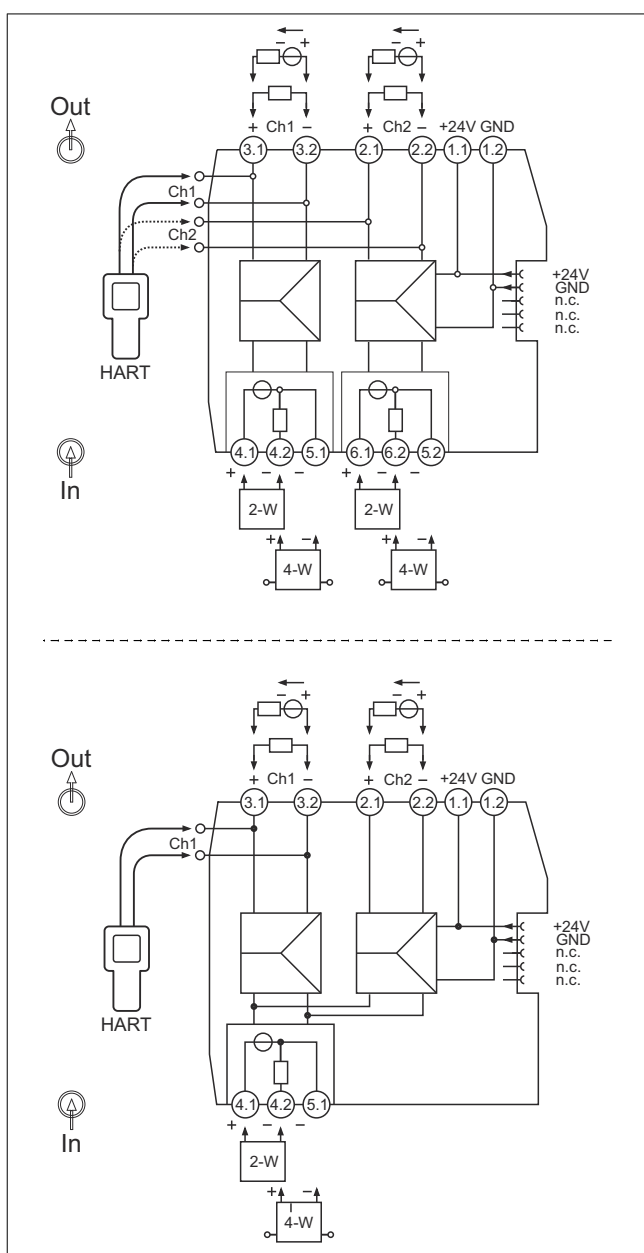

 3 Terminal assignment: 1- and 2-channel version (top), signal doubler (bottom)

 HART communicators can be connected to the HART connecting points. Ensure an adequate external resistance (≥ 230 Ω) in the output circuit.

**Connecting the supply voltage**

Power can be supplied via terminals 1.1 and 1.2 or via the DIN rail bus connector.

 The device may only be powered by a power unit with an energy-limited circuit in accordance with UL/EN/IEC 61010-1, Section 9.4 and the requirements of Table 18.

*Using the power and error message module to supply power*

It is recommended to use the RNF22 power and error message module to provide the supply voltage to the DIN rail bus connector. An overall current of 3.75 A is possible with this option.

*Supply to the DIN rail bus connector via terminals*

Devices installed side by side can be powered via the terminals of the device up to a total current consumption of 400 mA. The connection is via the DIN rail bus connector. The installation of a 630 mA fuse (semi-delay or slow-blow) upstream is recommended.

**NOTICE**

The simultaneous use of terminals and DIN rail bus connectors to supply power is not permitted! The tapping of energy from the DIN rail bus connector for further distribution is not permitted.

- ▶ The supply voltage must never be connected directly to the DIN rail bus connector!

## Display and operating elements

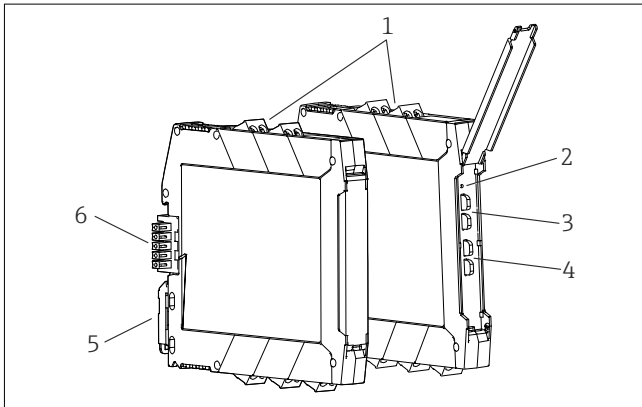

4 Display and operating elements

- 1 Plug-in screw or push-in terminal
- 2 Green LED "On", power supply
- 3 Connection lugs for HART communication (channel 1)
- 4 Connection lugs for HART communication (channel 2, option)
- 5 DIN rail clip for DIN rail mounting
- 6 DIN rail bus connector (optional)

## Local operation

### Hardware settings / configuration

No manual hardware settings are required at the device for commissioning.

Attention must be paid to the different terminal assignment when connecting 2/4-wire transmitters. At the output side, the connected system is detected and automatic switching takes place between the active and passive mode.

## Maintenance

No special maintenance work is required for the device.

### Cleaning

A clean, dry cloth can be used to clean the device.