

Brief Operating Instructions

Liquiphant FTL41

Vibronic
Point level switch in liquids



These Brief Operating Instructions are not a substitute for the Operating Instructions pertaining to the device.

Detailed information is provided in the Operating Instructions and other documentation.

Available for all device versions via:

- Internet: www.endress.com/deviceviewer
- Smartphone/tablet: Endress+Hauser Operations app

1 Associated documentation



A0023555

2 About this document

2.1 Symbols

2.1.1 Safety symbols



This symbol alerts you to a dangerous situation. Failure to avoid this situation will result in serious or fatal injury.



This symbol alerts you to a dangerous situation. Failure to avoid this situation can result in serious or fatal injury.

CAUTION

This symbol alerts you to a dangerous situation. Failure to avoid this situation can result in minor or medium injury.

NOTICE

This symbol contains information on procedures and other facts which do not result in personal injury.

2.1.2 Electrical symbols

 Ground connection

Grounded clamp, which is grounded via a grounding system.

 Protective earth (PE)

Ground terminals, which must be grounded prior to establishing any other connections. The ground terminals are located on the inside and outside of the device.

2.1.3 Tool symbols

 Flat-blade screwdriver

 Allen key

 Open-ended wrench

2.1.4 Symbols for certain types of information

 Permitted

Procedures, processes or actions that are permitted.

 Forbidden

Procedures, processes or actions that are forbidden.

 Tip

Indicates additional information

 Reference to documentation

 Reference to another section

 1, 2, 3. Series of steps

2.1.5 Symbols in graphics

A, B, C ... View

1, 2, 3 ... Item numbers

 Hazardous area

 Safe area (non-hazardous area)

3 Basic safety instructions

3.1 Requirements for the personnel

The personnel must fulfill the following requirements to carry out the necessary tasks, e. g., commissioning and maintenance:

- ▶ Trained, qualified specialists must have a relevant qualification for the specific function and task
- ▶ Are authorized by the plant owner/operator
- ▶ Are familiar with federal/national regulations
- ▶ Must have read and understood the instructions in the manual and supplementary documentation
- ▶ Follow instructions and comply with conditions

3.2 Intended use

- Only use the device for liquids
- Improper use can pose hazards
- Ensure that the measuring device is free of defects while it is in operation
- Use the device only for media to which the wetted materials have an adequate level of resistance
- Do not exceed or drop below the relevant limit values for the device
 - ▣ For more details, see the Technical Documentation

3.2.1 Incorrect use

The manufacturer is not liable for damage caused by improper or non-intended use.

Residual risks

Due to heat transfer from the process, the temperature of the electronics housing and the assemblies contained therein may rise to 80 °C (176 °F) during operation.

Danger of burns from contact with surfaces!

- ▶ If necessary, ensure protection against contact to prevent burns.

For requirements concerning functional safety in accordance with IEC 61508, the associated SIL documentation must be observed.

3.3 Workplace safety

For work on and with the device:

- ▶ Wear the required personal protective equipment according to federal/national regulations.

3.4 Operational safety

Risk of injury!

- ▶ Operate the device only if it is in proper technical condition, free from errors and faults.
- ▶ The operator is responsible for ensuring the interference-free operation of the device.

Modifications to the device

Unauthorized modifications to the device are not permitted and can lead to unforeseeable dangers.

- ▶ If, despite this, modifications are required, consult with Endress+Hauser.

Repair

To ensure continued operational safety and reliability:

- ▶ Only perform repair work on the device if this is expressly permitted.
- ▶ Observe federal/national regulations pertaining to the repair of an electrical device.
- ▶ Use original spare parts and accessories from Endress+Hauser only.

Hazardous area

To eliminate danger to persons or the facility when the device is used in the hazardous area (e.g. explosion protection):

- ▶ Check the nameplate to verify whether the ordered device can be used for the intended purpose in the hazardous area.
- ▶ Observe the specifications in the separate supplementary documentation that is an integral part of this manual.

3.5 Product safety

This device is designed in accordance with good engineering practice to meet state-of-the-art safety requirements, has been tested, and left the factory in a condition in which it is safe to operate.

It meets the general safety standards and legal requirements. It also complies with the EU directives listed in the device-specific EU Declaration of Conformity. Endress+Hauser confirms this by affixing the CE mark to the device.

3.6 IT security

We only provide a warranty if the device is installed and used as described in the Operating Instructions. The device has safety mechanisms integrated to prevent users from inadvertently changing settings.

Provide additional protection for the device and data transfer to/from the device

- ▶ IT security measures defined in the plant owner/operator's own security policy must be implemented by plant owners/operators themselves.

4 Incoming acceptance and product identification

4.1 Incoming acceptance

Check the following during incoming acceptance:

- Are the order codes on the delivery note and the product sticker identical?
- Are the goods undamaged?

- Do the data on the nameplate match the ordering information on the delivery note?
- If required (see nameplate): are the Safety Instructions e.g. XA provided?

 If one of these conditions is not met, please contact the manufacturer's sales office.

4.2 Product identification

The device can be identified in the following ways:

- Nameplate specifications
- Extended order code with breakdown of the device features on the delivery note
- Enter serial number from nameplates in *W@M Device Viewer* www.endress.com/deviceviewer. All of the information on the measuring device is displayed along with an overview of the scope of technical documentation provided.
- Enter the serial number on the nameplate into the *Endress+Hauser Operations app* or scan the 2-D matrix code on the nameplate with the *Endress+Hauser Operations app*

4.2.1 Electronic insert

 Identify the electronic insert via the order code on the nameplate.

4.2.2 Nameplate

The information that is required by law and is relevant to the device is shown on the nameplate.

4.2.3 Manufacturer address

Endress+Hauser SE+Co. KG
Hauptstraße 1
79689 Maulburg, Germany

Place of manufacture: See nameplate.

4.3 Storage and transport

4.3.1 Storage conditions

Use original packaging.

Storage temperature

-40 to +80 °C (-40 to +176 °F)

Transporting the device

- Transport the device to the measuring point in the original packaging
- Hold the device by the housing, flange or extension pipe
- Do not bend, shorten or extend the tuning fork

5 Mounting

Mounting instructions

- Any orientation for compact version or version with a pipe length up to approx. 500 mm (19.7 in)
- Vertical orientation from above for device with long pipe
- Minimum distance between the tuning fork and the tank wall or pipe wall: 10 mm (0.39 in)

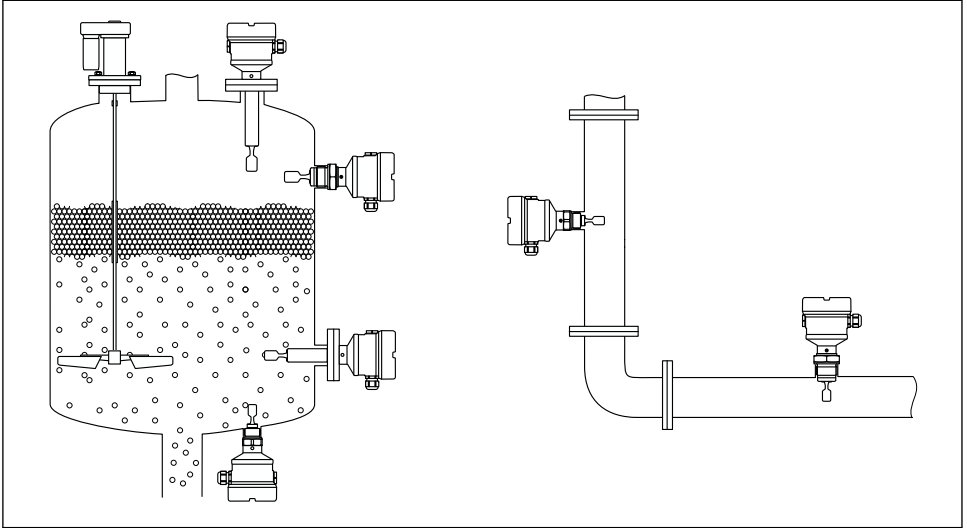

A0036954

 1 *Installation examples for a vessel, tank or pipe*

5.1 Mounting requirements

5.1.1 Take switch point into consideration

The following are typical switch points, depending on the orientation of the point level switch.

Water +23 °C (+73 °F)

-  Minimum distance between the tuning fork and the tank wall or pipe wall:
10 mm (0.39 in)

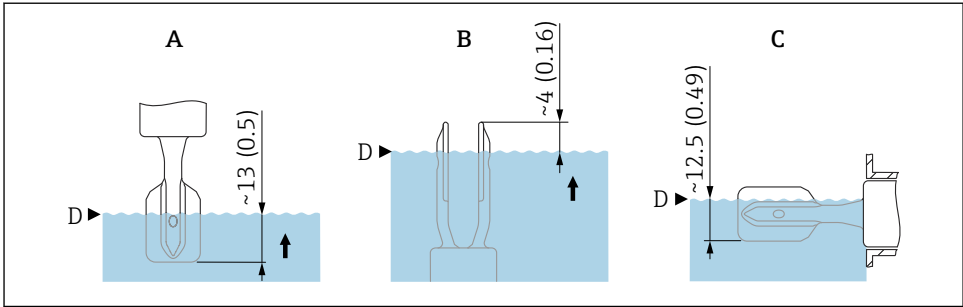

A0037915

2 Typical switch points. Unit of measurement mm (in)

- A Installation from above
- B Installation from below
- C Installation from the side
- D Switch point

5.1.2 Take viscosity into consideration

i Viscosity values

- Low viscosity : < 2 000 mPa·s
- High viscosity : > 2 000 to 10 000 mPa·s

Low viscosity

- i** It is permitted to position the tuning fork within the installation socket.

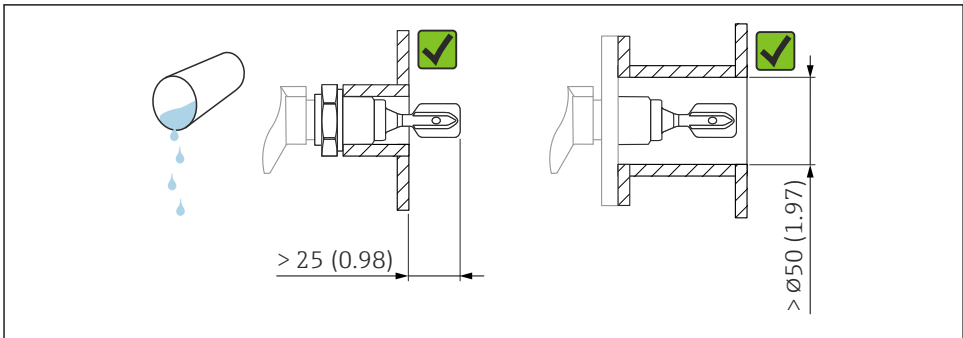

A0033297

3 Installation example for low-viscosity liquids. Unit of measurement mm (in)

High viscosity

NOTICE

Highly viscous liquids may cause switching delays.

- ▶ Make sure that the liquid can run off the tuning fork easily.
- ▶ Deburr the socket surface.

 The tuning fork must be located outside the installation socket!

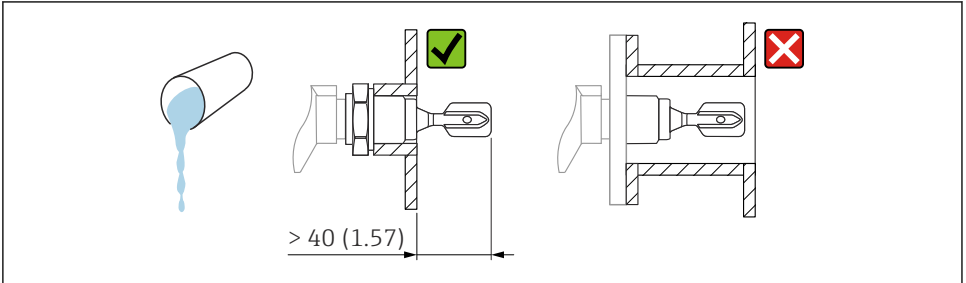

A0037348

 4 Installation example for a highly viscous liquid. Unit of measurement mm (in)

5.1.3 Avoid buildup

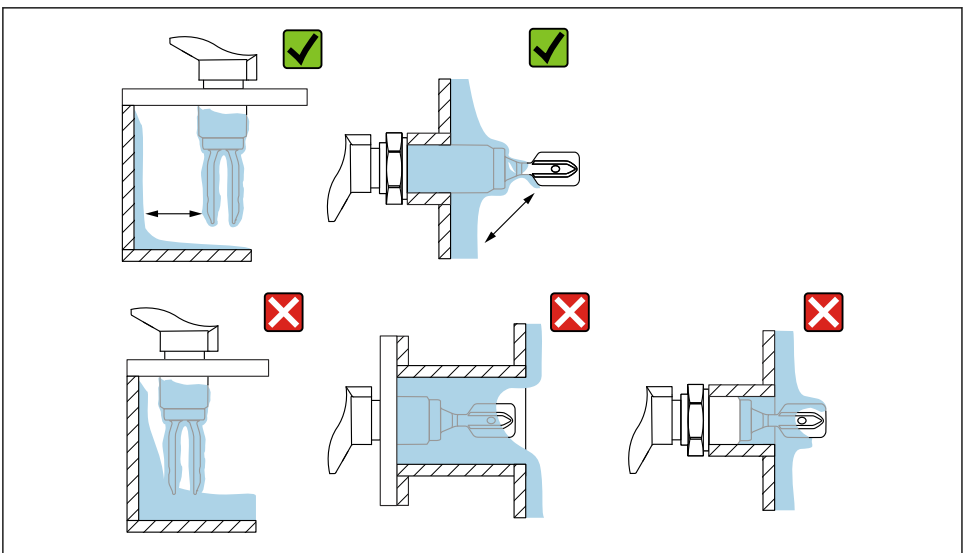

A0033239

 5 Installation examples for a highly viscous process medium

5.1.4 Take clearance into consideration

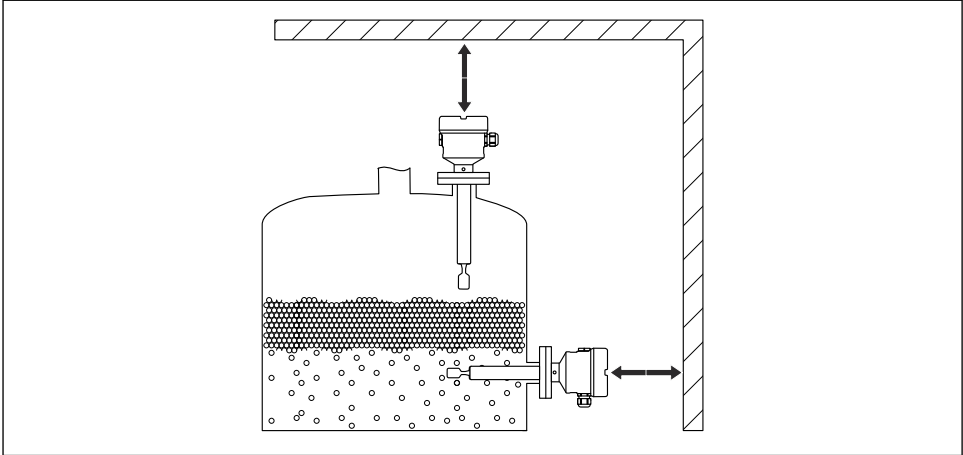

6 Take clearance outside the tank into consideration

5.1.5 Support the device

Support the device in the event of severe dynamic load. Maximum lateral loading capacity of the pipe extensions and sensors: 75 Nm (55 lbf ft).

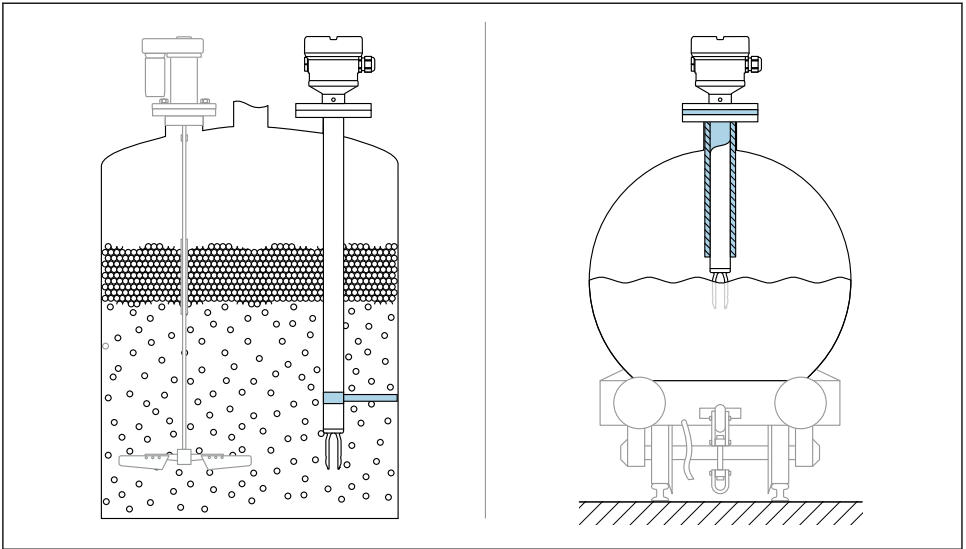

A0031874

7 Examples of support in the event of dynamic load

i Marine approval: In the case of pipe extensions or sensors longer than 1 600 mm (63 in), a support is needed at least every 1 600 mm (63 in).

5.1.6 Weld-in adapter with leakage hole

Weld in the weld-in adapter in such a way that the leakage hole is pointing downwards. This enables any leaks to be detected quickly.

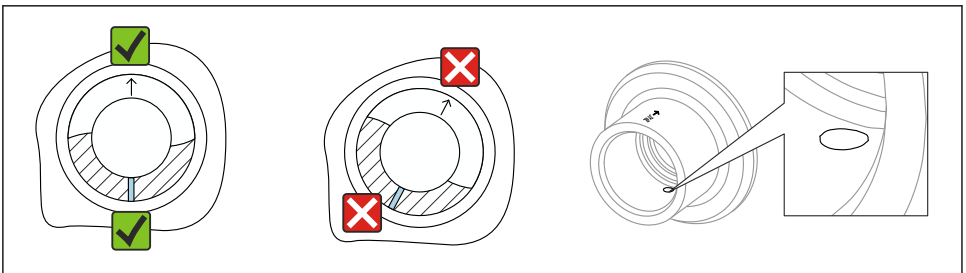

A0039230

8 Weld-in adapter with leakage hole

5.2 Mounting the device

5.2.1 Required tool

- Open-ended wrench for sensor installation
- Allen key for housing locking screw

5.2.2 Installation

Aligning the tuning fork using the marking

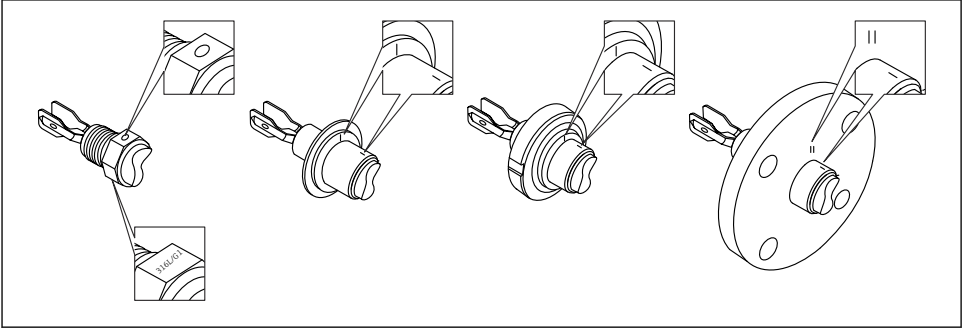

A0039125

9 Position of the tuning fork when installed horizontally in the vessel using the marking

Installing the device in piping

- Flow velocity up to 5 m/s with a viscosity of 1 mPa·s and density of 1 g/cm³ (62.4 lb/ft³) (SGU).
Check for correct functioning in the event of other process medium conditions.
- The flow will not be significantly impeded if the tuning fork is correctly aligned and the marking is pointing in the direction of flow.
- The marking is visible when installed

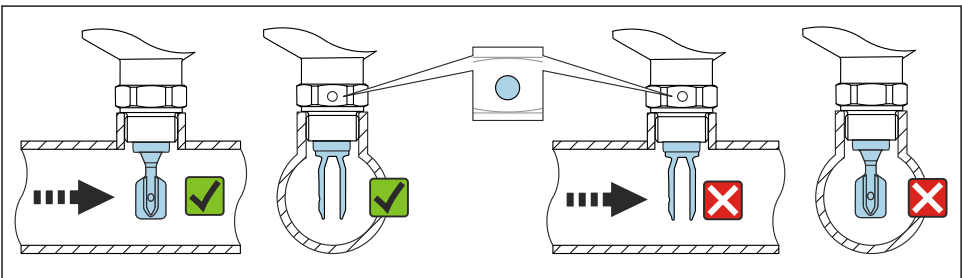

A0034851

10 Installation in pipes (take fork position and marking into consideration)

Screwing in the device

- Turn by the hex bolt only, 15 to 30 Nm (11 to 22 lbf ft)
- Do not turn at the housing!

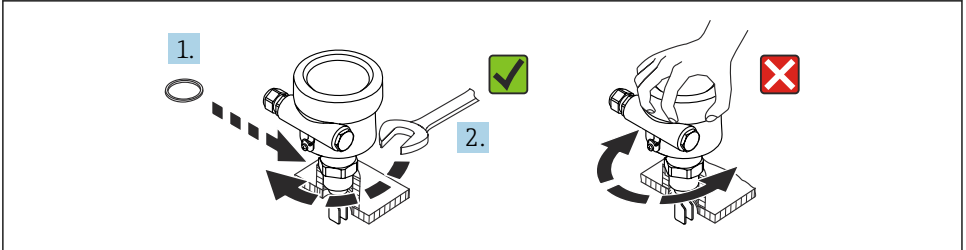

A0034852

11 Screwing in the device

Aligning the cable entry

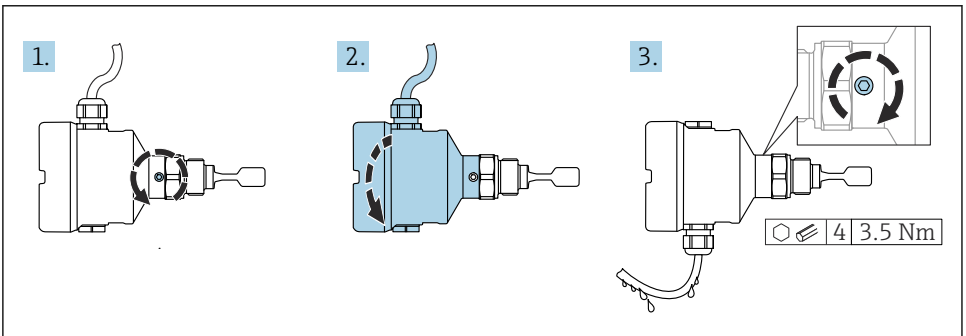

A0037347

12 Housing with external locking screw and drip loop



Housings with locking screw:

- The housing can be turned and the cable aligned by turning the locking screw.
- The locking screw is not tightened when the device is delivered.

1. Loosen the external locking screw (maximum 1.5 turns).
2. Turn the housing, align the cable entry.
 - ↳ Avoid moisture in the housing, provide a loop to allow moisture to drain off.
3. Tighten the external locking screw.

NOTICE**The housing cannot be unscrewed fully.**

- ▶ Loosen the external locking screw by a maximum of 1.5 turns. If the screw is unscrewed too much or completely (beyond the screw anchor point), small parts (counter disk) can become loose and fall out.
- ▶ Tighten the securing screw (hexagon socket 4 mm (0.16 in)) with maximum 3.5 Nm (2.58 lbf ft)±0.3 Nm (±0.22 lbf ft).

*Closing the housing covers***NOTICE****Thread and housing cover damaged from dirt and fouling!**

- ▶ Remove dirt (e.g. sand) on the thread of the covers and housing.
- ▶ If you continue to encounter resistance when closing the cover, check the thread again for fouling.

**Housing thread**

The threads of the electronics and connection compartment can be coated with an anti-friction coating.

The following applies for all housing materials:

- ✘ **Do not lubricate the housing threads.**

6 Electrical connection

6.1 Required tool

- Screwdriver for electrical connection
- Allen key for screw of cover lock

6.2 Connecting requirements

6.2.1 Cover with securing screw

The cover is locked by a securing screw in devices for use in hazardous areas with certain explosion protection.

NOTICE**If the securing screw is not positioned correctly, the cover cannot provide secure sealing.**

- ▶ Open the cover: slacken the screw of the cover lock with a maximum of 2 turns so that the screw does not fall out. Fit the cover and check the cover seal.
- ▶ Close the cover: screw the cover securely onto the housing, making sure that the securing screw is positioned correctly. There should not be any gap between the cover and housing.

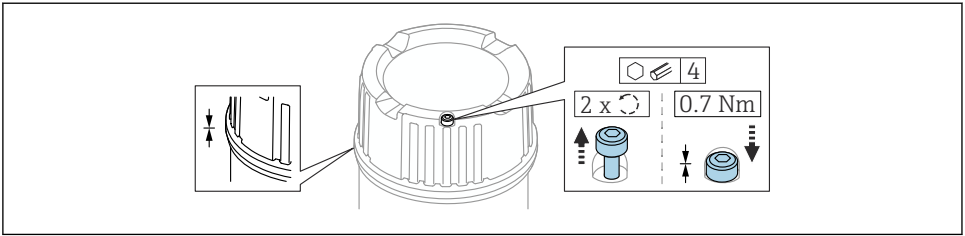

A0039520

13 Cover with securing screw

6.2.2 Connecting protective earth (PE)

The protective earth conductor at the device must only be connected if the device's operating voltage is $\geq 35 V_{DC}$ or $\geq 16 V_{ACeff}$.

When the device is used in hazardous areas, it must always be included in the potential equalization of the system, irrespective of the operating voltage.

i The plastic housing is available with or without an external protective earth connection (PE). If the operating voltage of the electronic insert is $< 35 V$, the plastic housing has no external protective earth connection.

6.3 Connecting the device

i Housing thread

The threads of the electronics and connection compartment can be coated with an anti-friction coating.

The following applies for all housing materials:

✘ Do not lubricate the housing threads.

6.3.1 3-wire DC-PNP (electronic insert FEL42)

- Three-wire DC version
- Switches the load via the transistor (PNP) and separate connection, e.g. in conjunction with programmable logic controllers (PLC), DI modules according to EN 61131-2

Supply voltage

⚠ WARNING

Failure to use the prescribed power unit.

Risk of potentially life-threatening electric shock!

- ▶ The FEL42 may only be powered by power supply units with secure galvanic isolation in accordance with IEC 61010-1.

$$U = 10 \text{ to } 55 \text{ V}_{\text{DC}}$$

 The device must be powered by a voltage supply categorized as "CLASS 2" or "SELV".

 Comply with the following according to IEC/EN61010-1: provide a suitable circuit breaker for the device and limit the current to 500 mA, e.g. by installing a 0.5 A fuse (slow-blow) in the power supply circuit.

Power consumption

$$P < 0.5 \text{ W}$$

Current consumption

$$I \leq 10 \text{ mA (without load)}$$

The red LED flashes in the event of an overload or short-circuit. Check for an overload or short-circuit every 5 s.

Load current

$$I \leq 350 \text{ mA with overload and short-circuit protection}$$

Residual current

$$I < 100 \text{ }\mu\text{A (for blocked transistor)}$$

Residual voltage

$$U < 3 \text{ V (for switched through transistor)}$$

Behavior of output signal

- OK status: switched through
- Demand mode: blocked
- Alarm: blocked

Terminals

Terminals for cable cross-section up to 2.5 mm² (14 AWG). Use ferrules for the wires.

Overvoltage protection

Overvoltage category I

Terminal assignment

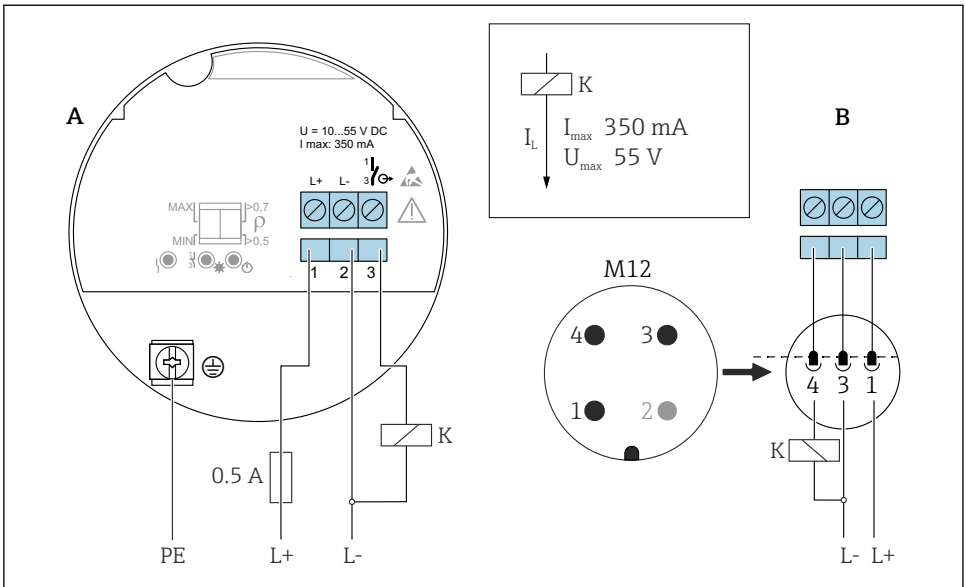

A0036056

14 Terminal assignment FEL42

A Terminal assignment at electronic insert

B Terminal assignment at M12 plug according to EN61131-2 standard

Behavior of the switch output and signaling

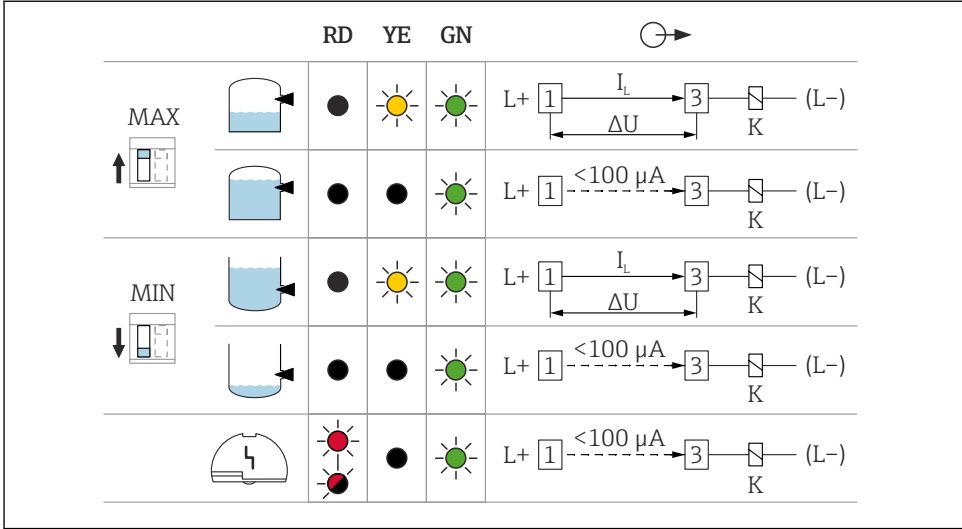

A0033508

15 FEL42 switching behavior, signaling LED

MAXDIP switch for setting the MAX safety

MIN DIP switch for setting the MIN safety

RD LED red for warning or alarm

YE LED yellow, switch status

GN LED green, operational status, device on

I_L Load current switched through

6.3.2 Universal current connection with relay output (electronic insert FEL44)

- Switches the loads via 2 potential-free change-over contacts
- 2 separate change-over contacts (DPDT)

WARNING

An error at the electronic insert can cause the permitted temperature for touch-safe surfaces to be exceeded. This presents a risk of burns.

- Do not touch the electronics in the event of an error!

Supply voltage

$U = 19 \text{ to } 253 \text{ V}_{AC} / 19 \text{ to } 55 \text{ V}_{DC}$

- Comply with the following according to IEC/EN61010-1: provide a suitable circuit breaker for the device and limit the current to 500 mA, e.g. by installing a 0.5 A fuse (slow-blow) in the power supply circuit.

Power consumption

$S < 25 \text{ VA}$, $P < 1.3 \text{ W}$

Connectable load

Loads switched via 2 potential-free changeover contacts (DPDT)

- $I_{AC} \leq 6 \text{ A}$, $U_{\sim} \leq \text{AC } 253 \text{ V}$; $P_{\sim} \leq 1500 \text{ VA}$, $\cos \varphi = 1$, $P_{\sim} \leq 750 \text{ VA}$, $\cos \varphi > 0.7$
- $I_{DC} \leq 6 \text{ A}$ to DC 30 V, $I_{DC} \leq 0.2 \text{ A}$ to 125 V



Additional restrictions for the connectable load depend on the selected approval. Pay attention to the information in the Safety Instructions (XA).

According to IEC 61010, the following applies: Total voltage from relay outputs and power supply $\leq 300 \text{ V}$.

Use electronic insert FEL42 DC PNP for small DC load currents, e.g. for connection to a PLC.

Relay contact material: silver/nickel AgNi 90/10

When connecting a device with high inductance, provide a spark suppressor to protect the relay contact. A fine-wire fuse (depending on the connected load) protects the relay contact in the event of a short-circuit.

Both relay contacts switch simultaneously.

Behavior of output signal

- OK status: relay energized
- Demand mode: relay de-energized
- Alarm: relay de-energized

Terminals

Terminals for cable cross-section up to 2.5 mm^2 (14 AWG). Use ferrules for the wires.

Overvoltage protection

Overvoltage category II



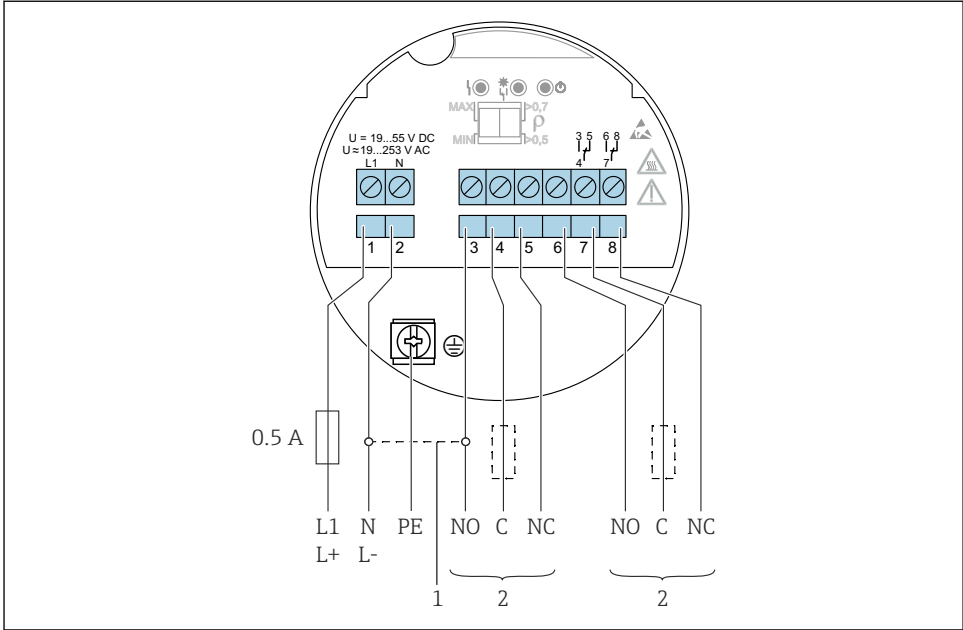







Terminal assignment

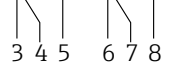

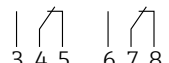
16 Universal current connection with relay output, electronic insert FEL44

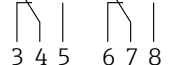
- 1 When bridged, the relay output works with NPN logic
- 2 Connectable load

Behavior of the switch output and signaling

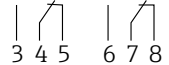
		RD	YE	GN	
MAX ↑ 		●	☀	☀	
		●	●	☀	
MIN ↓ 		●	☀	☀	
		●	●	☀	
		☀	●	☀	

A0033513

17 FEL44 switching behavior, signaling LED

MAXDIP switch for setting the MAX safety

MIN DIP switch for setting the MIN safety

RD LED red for alarm

YE LED yellow, switch status

GN LED green, operational status, device on

6.3.3 2-wire NAMUR > 2.2 mA / < 1.0 mA (electronic insert FEL48)

- To connect to isolating amplifiers according to NAMUR (IEC 60947-5-6), e.g. Nivotester FTL325N from Endress+Hauser
- To connect to isolating amplifiers of third-party suppliers according to NAMUR (IEC 60947-5-6), a permanent power supply for the electronic insert FEL48 must be ensured
- Signal transmission H-L edge 2.2 to 3.8 mA / 0.4 to 1.0 mA according to NAMUR (IEC 60947-5-6) on two-wire cabling

Supply voltage

$$U = 8.2 V_{DC}$$



The device must be powered by a voltage supply categorized as "CLASS 2" or "SELV".



Comply with the following according to IEC/EN61010-1: provide a suitable circuit breaker for the device.

Power consumption

$P < 50 \text{ mW}$

Behavior output signal

- OK state: Current 2.2 to 3.8 mA
- Demand mode: Current 0.4 to 1.0 mA
- Alarm: Current 0.4 to 1.0 mA

Terminals

Terminals for cable cross-section up to 2.5 mm^2 (14 AWG). Use ferrules for the wires.

Overvoltage protection

Overvoltage category I



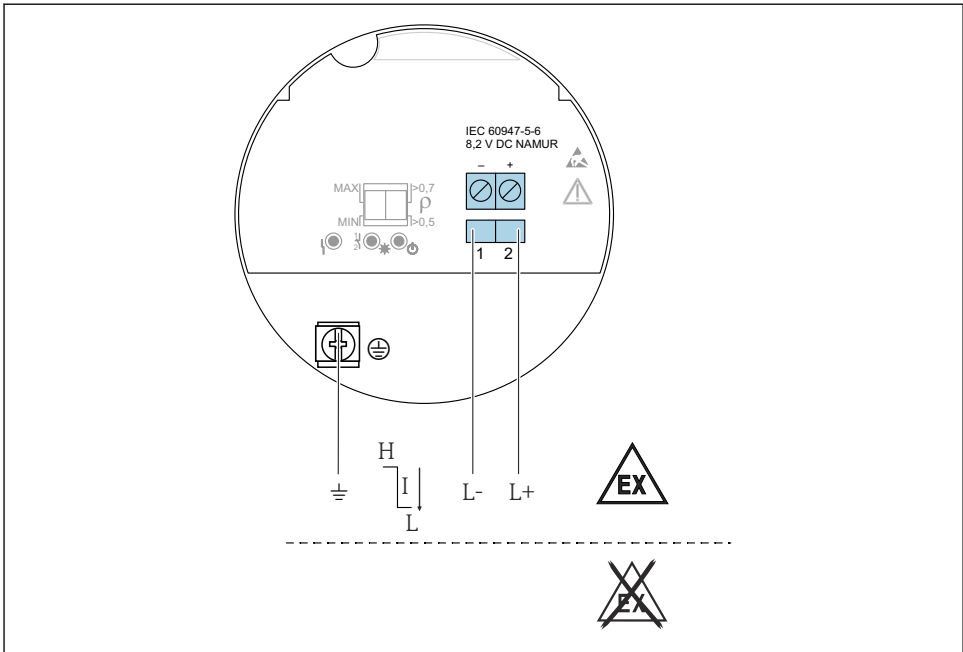



















Terminal assignment



A0036058

18 2-wire NAMUR $\geq 2.2 \text{ mA} / \leq 1.0 \text{ mA}$, electronic insert FEL48

Behavior of the switch output and signaling

		RD	YE	GN	
MAX 					L+ [2] $2.2...3.8 \text{ mA}$ [1] L-
					L+ [2] $0.4...1.0 \text{ mA}$ [1] L-
MIN 					L+ [2] $2.2...3.8 \text{ mA}$ [1] L-
					L+ [2] $0.4...1.0 \text{ mA}$ [1] L-
					L+ [2] $< 1.0 \text{ mA}$ [1] L-

A0037694

19 FEL48 switching behavior and signaling

MAXDIP switch for setting the MAX safety

MIN DIP switch for setting the MIN safety

RD LED red for alarm

YE LED yellow, switch status

GN LED green, operational status, device on

6.3.4 Connecting the cables

Required tools

- Flat-blade screwdriver (0.6 mm x 3.5 mm) for terminals
- Suitable tool with width across flats AF24/25 (8 Nm (5.9 lbf ft)) for M20 cable gland

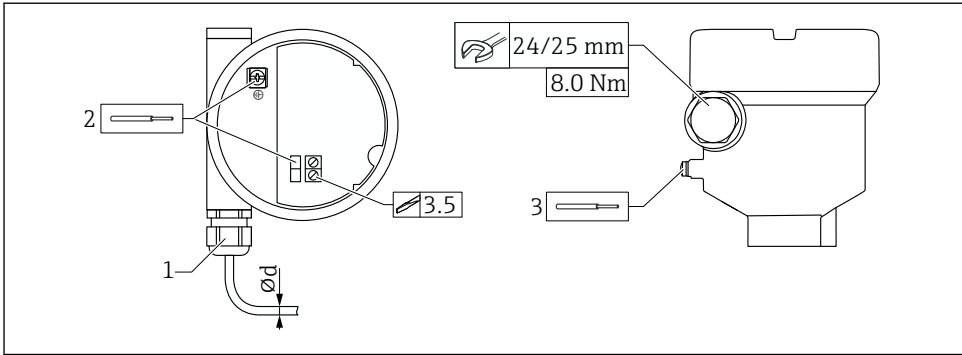

20 Example of coupling with cable entry, electronic insert with terminals

- 1 M20 coupling (with cable entry), example
 - 2 Conductor cross-section maximum 2.5 mm^2 (AWG14), ground terminal on inside in housing + terminals on the electronics
 - 3 Conductor cross-section maximum 4.0 mm^2 (AWG12), ground terminal on outside of the housing (example: plastic housing with outer protective ground connection (PE))
- Ød Nickel-plated brass 7 to 10.5 mm (0.28 to 0.41 in),
 Plastic 5 to 10 mm (0.2 to 0.38 in),
 Stainless steel 7 to 12 mm (0.28 to 0.47 in)

i Pay attention to the following when using the M20 coupling

Following cable entry:

- Counter-tighten the coupling
- Tighten the union nut of the coupling with 8 Nm (5.9 lbf ft)
- Screw the enclosed coupling into the housing with 3.75 Nm (2.76 lbf ft)

7 Operation options

7.1 Overview of operation options

7.1.1 Operation concept

Operation with DIP switches on the electronic insert

7.1.2 Elements on the electronic insert

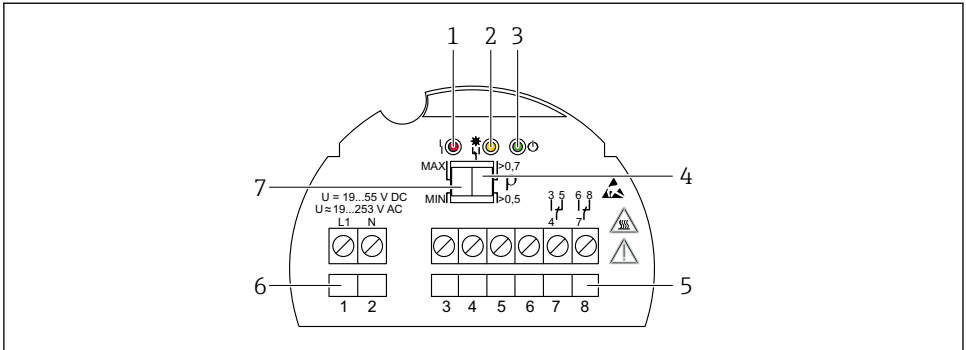

A0039317

 21 Example of electronic insert FEL44

- 1 LED red, for warning or alarm
- 2 LED yellow, switch status
- 3 LED green, operational status (LED green lights up = device on)
- 4 DIP switch to set the density to 0.7 or 0.5
- 5 Relay contact terminals
- 6 Power supply terminals
- 7 DIP switch for setting MAX/MIN safety

8 Commissioning

8.1 Function check

See Operating Instructions.

8.2 Switching on the device

During the power-up time, the device output is in the safety-oriented state, or in the alarm state if available.

The output is in the correct state after a maximum of 3 s following device power-up.

8.3 Further information



Further information and the documentation currently available can be found on the Endress+Hauser website: www.endress.com → Downloads.



71624364

www.addresses.endress.com
