

# Brief Operating Instructions

## Liquiphant FTL62 Density

Vibronic

Density measurement for liquids



These Brief Operating Instructions are not a substitute for the Operating Instructions pertaining to the device.

Detailed information is provided in the Operating Instructions and other documentation.

Available for all device versions via:

- Internet: [www.endress.com/deviceviewer](http://www.endress.com/deviceviewer)
- Smartphone/tablet: Endress+Hauser Operations app

# 1 Associated documentation



A0023555

## 2 About this document

### 2.1 Symbols

#### 2.1.1 Safety symbols



This symbol alerts you to a dangerous situation. Failure to avoid this situation will result in serious or fatal injury.



This symbol alerts you to a dangerous situation. Failure to avoid this situation can result in serious or fatal injury.

### CAUTION

This symbol alerts you to a dangerous situation. Failure to avoid this situation can result in minor or medium injury.

### NOTICE

This symbol contains information on procedures and other facts which do not result in personal injury.

## 2.1.2 Electrical symbols

 Ground connection

Grounded clamp, which is grounded via a grounding system.

 Protective earth (PE)

Ground terminals, which must be grounded prior to establishing any other connections. The ground terminals are located on the inside and outside of the device.

## 2.1.3 Tool symbols

 Flat-blade screwdriver

 Allen key

 Open-ended wrench

## 2.1.4 Symbols for certain types of information

 Permitted

Procedures, processes or actions that are permitted.

 Forbidden

Procedures, processes or actions that are forbidden.

 Tip

Indicates additional information

 Reference to documentation

 Reference to another section

 1, 2, 3. Series of steps

## 2.1.5 Symbols in graphics

**A, B, C ...** View

1, 2, 3 ... Item numbers

 Hazardous area

 Safe area (non-hazardous area)

## 3 Basic safety instructions

### 3.1 Requirements for the personnel

The personnel must fulfill the following requirements to carry out the necessary tasks, e. g., commissioning and maintenance:

- ▶ Trained, qualified specialists must have a relevant qualification for the specific function and task
- ▶ Are authorized by the plant owner/operator
- ▶ Are familiar with federal/national regulations
- ▶ Must have read and understood the instructions in the manual and supplementary documentation
- ▶ Follow instructions and comply with conditions

### 3.2 Intended use

- Use the device only for measuring the density of liquids
- Improper use can pose hazards
- The plant owner/operator must ensure that the device remains in proper operating condition for its service life
- Use the device only for media to which the wetted materials have an adequate level of resistance
- Do not exceed or drop below the relevant limit values for the device
  - ▣ See the Technical Documentation

#### 3.2.1 Incorrect use

The manufacturer is not liable for damage caused by improper or non-intended use.

#### Residual risks

Due to heat transfer from the process, the temperature of the electronics housing and the assemblies contained therein may rise to 80 °C (176 °F) during operation.

Danger of burns from contact with surfaces!

- ▶ If necessary, ensure protection against contact to prevent burns.

### 3.3 Workplace safety

For work on and with the device:

- ▶ Wear the required personal protective equipment according to federal/national regulations.

### 3.4 Operational safety

Risk of injury!

- ▶ Operate the device only if it is in proper technical condition, free from errors and faults.
- ▶ The operator is responsible for ensuring the interference-free operation of the device.

## Modifications to the device

Unauthorized modifications to the device are not permitted and can lead to unforeseeable dangers.

- ▶ If, despite this, modifications are required, consult with Endress+Hauser.

## Repair

To ensure continued operational safety and reliability:

- ▶ Only perform repair work on the device if this is expressly permitted.
- ▶ Observe federal/national regulations pertaining to the repair of an electrical device.
- ▶ Use original spare parts and accessories from Endress+Hauser only.

## Hazardous area

To eliminate danger to persons or the facility when the device is used in the hazardous area (e.g. explosion protection):

- ▶ Check the nameplate to verify whether the ordered device can be used for the intended purpose in the hazardous area.
- ▶ Observe the specifications in the separate supplementary documentation that is an integral part of this manual.

## 3.5 Product safety

This device is designed in accordance with good engineering practice to meet state-of-the-art safety requirements, has been tested, and left the factory in a condition in which it is safe to operate.

It meets the general safety standards and legal requirements. It also complies with the EU directives listed in the device-specific EU Declaration of Conformity. Endress+Hauser confirms this by affixing the CE mark to the device.

## 3.6 IT security

We only provide a warranty if the device is installed and used as described in the Operating Instructions. The device has safety mechanisms integrated to prevent users from inadvertently changing settings.

Provide additional protection for the device and data transfer to/from the device

- ▶ IT security measures defined in the plant owner/operator's own security policy must be implemented by plant owners/operators themselves.

# 4 Incoming acceptance and product identification

## 4.1 Incoming acceptance

Check the following during incoming acceptance:

- Are the order codes on the delivery note and the product sticker identical?
- Are the goods undamaged?

- Do the data on the nameplate match the ordering information on the delivery note?
- If required (see nameplate): are the Safety Instructions e.g. XA provided?



If one of these conditions is not met, please contact the manufacturer's sales office.

## 4.2 Product identification

The measuring device can be identified in the following ways:

- Nameplate specifications
- Extended order code with breakdown of the device features on the delivery note
- Enter serial number from nameplates in *W@M Device Viewer* ([www.endress.com/deviceviewer](http://www.endress.com/deviceviewer)): All the information about the measuring device and an overview of the Technical Documentation supplied are displayed.
- Enter the serial number on the nameplate into the *Endress+Hauser Operations app* or scan the 2-D matrix code on the nameplate with the *Endress+Hauser Operations app*

### 4.2.1 Nameplate

The information that is required by law and is relevant to the device is shown on the nameplate, e.g.:

- Manufacturer identification
- Order number, extended order code, serial number
- Technical data, degree of protection
- Firmware version, hardware version
- Approval-related information, reference to Safety Instructions (XA)
- DataMatrix code (information about the device)

### 4.2.2 Manufacturer address

Endress+Hauser SE+Co. KG  
Hauptstraße 1  
79689 Maulburg, Germany

Place of manufacture: See nameplate.

## 4.3 Storage and transport

### 4.3.1 Storage conditions

Use original packaging.

#### Storage temperature

-40 to +80 °C (-40 to +176 °F)

### 4.3.2 Transporting the device

#### NOTICE

Flange, pipe extension and tuning fork are either plastic-coated or enamel-coated. Scratches or impacts may cause damage to the coated surface of the device.

- ▶ Hold the device only by the housing, flange or extension pipe, protect coated surface appropriately.
- ▶ Transport the device to the measuring point in the original packaging.
- ▶ Do not bend, shorten or extend the tuning fork.

## 5 Mounting

Mounting instructions

- Any orientation for version with a pipe length of up to 500 mm (19.7 in) approx.
- Vertical orientation from above for device with long pipe
- Minimum distance between the fork tip and the tank wall or pipe wall: 10 mm (0.39 in)

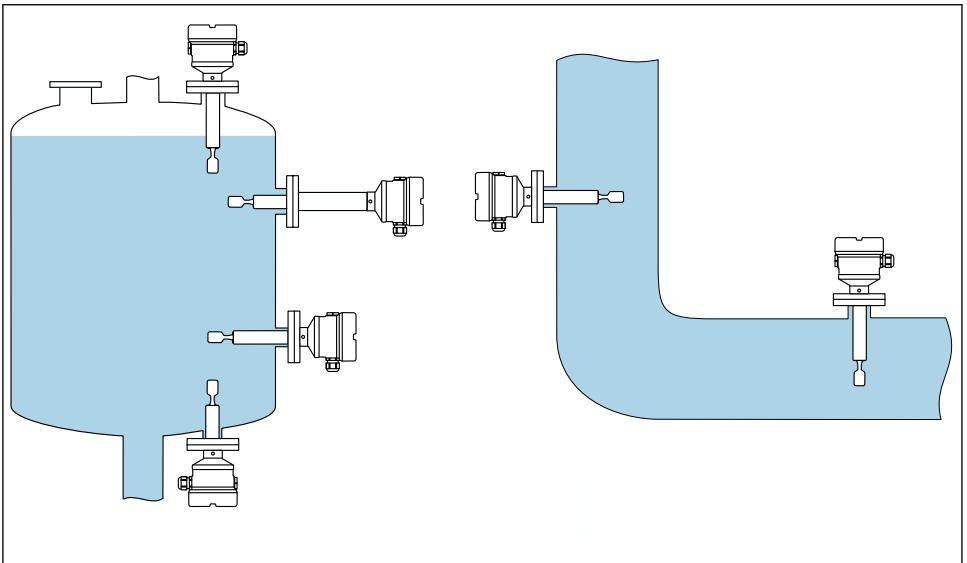

A0048473

 1 Installation examples for a vessel, tank or pipe

### 5.1 Mounting requirements

For density measurement, the tuning fork must always be completely immersed.

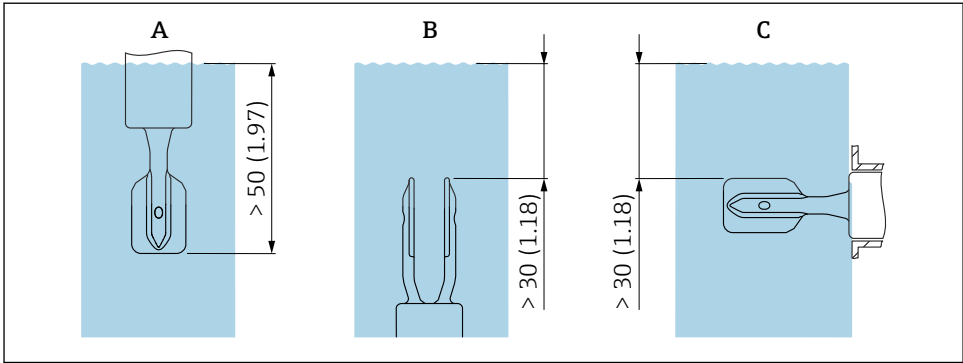

A0039685

Unit of measurement mm (in)

- A Installation from above
- B Installation from below
- C Installation from the side

**5.1.1 Flow velocity - Installation in piping**

**Install the tuning fork within the medium flow**

- Flow velocity: < 2 m/s (6.56 ft/s) per second
- Prevents the formation of air bubbles (1)

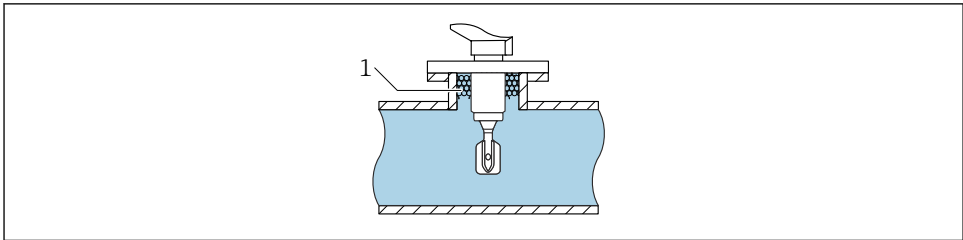

A0039718

- 2 Installation example in pipes within the media flow

**Install the tuning fork away from the direct flow of medium**

Flow velocity: < 2 m/s (6.56 ft/s)



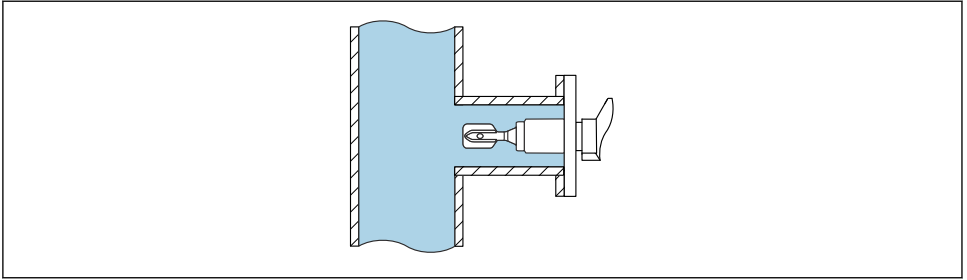

A0039721

3 Installation example in pipes away from the direct flow of medium

### 5.1.2 Inlet and outlet runs

#### Inlet run

If possible, install the sensor as far upstream as possible, e.g. valves, T-pieces, elbows, flange elbows, etc.

To comply with the accuracy specification, the inlet run must meet the following requirements:

Inlet run:  $\geq 5 \times \text{DN}$  (nominal diameter) - min. 750 mm (29.5 in)

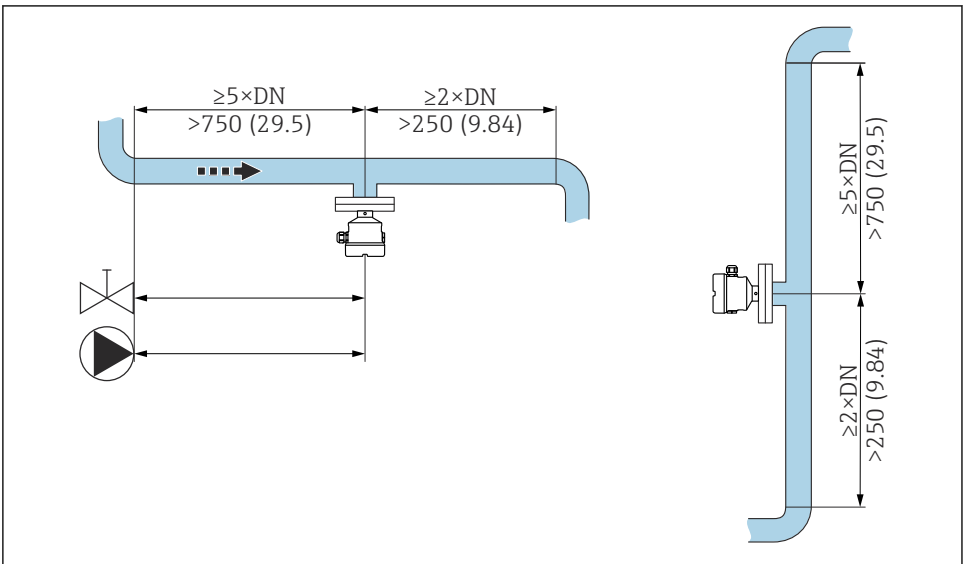

A0039700

4 Installing the inlet run. Unit of measurement mm (in)

## Outlet run

To comply with the accuracy specification, the outlet run must meet the following requirements:

Outlet run:  $\geq 2x$  DN (nominal diameter) - min. 250 mm (9.84 in)

The pressure and temperature sensor must be installed on the outlet side of the flow direction after the Liquiphant density sensor. When installing pressure and temperature measuring points downstream of the device, make sure the distance between the measuring point and the measuring device is sufficient.

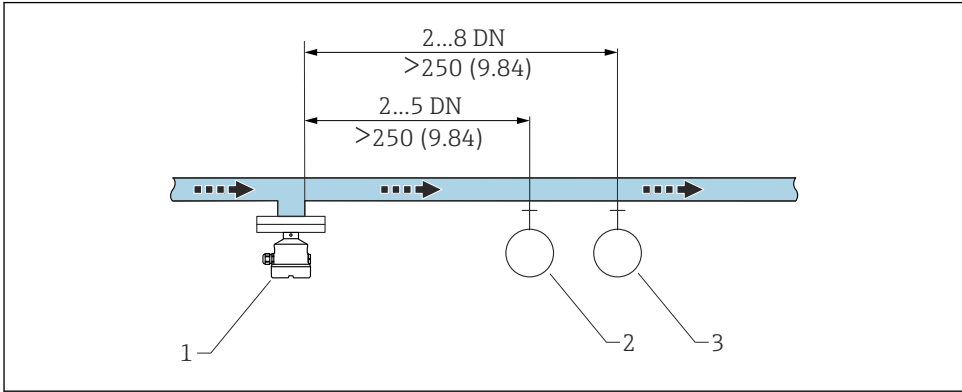

A0039701

5 Installing the outlet run. Unit of measurement mm (in)

- 1 Liquiphant density sensor
- 2 Pressure measuring point
- 3 Temperature measuring point

### 5.1.3 Correction factor

If the vibration of the tuning fork is affected by conditions at the mounting location, the measurement result can be adjusted using a correction factor (r).

## Standard installation

Correction factor "r" as a factor of height "h", for entering in the Density Computer FML621 or ReadWin2000:

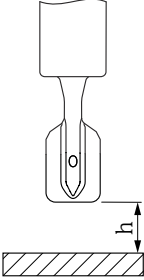
	h	r
 A0039687	12 mm (0.47 in)	1.0026
	14 mm (0.55 in)	1.0016
	16 mm (0.63 in)	1.0011
	18 mm (0.71 in)	1.0008
	20 mm (0.79 in)	1.0006
	22 mm (0.87 in)	1.0005
	24 mm (0.94 in)	1.0004
	26 mm (1.02 in)	1.0004
	28 mm (1.10 in)	1.0004
	30 mm (1.18 in)	1.0003
	32 mm (1.26 in)	1.0003
	34 mm (1.34 in)	1.0002
	36 mm (1.42 in)	1.0001
	38 mm (1.50 in)	1.0001
	40 mm (1.57 in)	1.0000

## Installation in a bypass

Correction factor "r" as a factor of the internal diameter of bypass "D", for entering in the Density Computer FML621 or ReadWin2000:

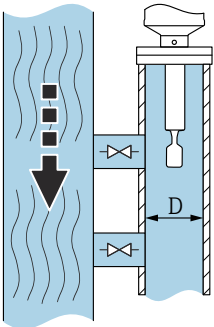
	D	r
 A0039689	<44 mm (1.73 in)	-
	44 mm (1.73 in)	1.0191
	46 mm (1.81 in)	1.0162
	48 mm (1.89 in)	1.0137
	50 mm (1.97 in)	1.0116
	52 mm (2.05 in)	1.0098
	54 mm (2.13 in)	1.0083
	56 mm (2.20 in)	1.0070
	58 mm (2.28 in)	1.0059
	60 mm (2.36 in)	1.0050

	D	r
	62 mm (2.44 in)	1.0042
	64 mm (2.52 in)	1.0035
	66 mm (2.60 in)	1.0030
	68 mm (2.68 in)	1.0025
	70 mm (2.76 in)	1.0021
	72 mm (2.83 in)	1.0017
	74 mm (2.91 in)	1.0014
	76 mm (2.99 in)	1.0012
	78 mm (3.07 in)	1.0010
	80 mm (3.15 in)	1.0008
	82 mm (3.23 in)	1.0006
	84 mm (3.31 in)	1.0005
	86 mm (3.39 in)	1.0004
	88 mm (3.46 in)	1.0003
	90 mm (3.54 in)	1.0003
	92 mm (3.62 in)	1.0002
	94 mm (3.70 in)	1.0002
	96 mm (3.78 in)	1.0001
	98 mm (3.86 in)	1.0001
	100 mm (3.94 in)	1.0001
	>100 mm (3.94 in)	1.0000

### Installation in pipe

Correction factor "r" as a factor of the internal diameter of pipe "D", for entering in the Density Computer FML621 or ReadWin2000:

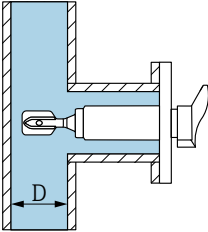
	D	r
	<44 mm (1.73 in)	-
	44 mm (1.73 in)	1.0225
	46 mm (1.81 in)	1.0167
	48 mm (1.89 in)	1.0125
	50 mm (1.97 in)	1.0096
	52 mm (2.05 in)	1.0075
	54 mm (2.13 in)	1.0061

	D	r
	56 mm (2.20 in)	1.0051
	58 mm (2.28 in)	1.0044
	60 mm (2.36 in)	1.0039
	62 mm (2.44 in)	1.0035
	64 mm (2.52 in)	1.0032
	66 mm (2.60 in)	1.0028
	68 mm (2.68 in)	1.0025
	70 mm (2.76 in)	1.0022
	72 mm (2.83 in)	1.0020
	74 mm (2.91 in)	1.0017
	76 mm (2.99 in)	1.0015
	78 mm (3.07 in)	1.0012
	80 mm (3.15 in)	1.0009
	82 mm (3.23 in)	1.0007
	84 mm (3.31 in)	1.0005
	86 mm (3.39 in)	1.0004
	88 mm (3.46 in)	1.0003
	90 mm (3.54 in)	1.0002
	92 mm (3.62 in)	1.0002
	94 mm (3.70 in)	1.0001
	96 mm (3.78 in)	1.0001
	98 mm (3.86 in)	1.0001
	100 mm (3.94 in)	1.0001
	>100 mm (3.94 in)	1.0000

#### 5.1.4 Avoid buildup

##### NOTICE

**The presence of buildup or corrosion on the tuning fork affects the result of the measurement and must be avoided!**

- ▶ Allow for maintenance intervals if required!

#### 5.1.5 Take clearance into consideration

Allow sufficient space outside the tank for mounting, connecting and replacing the electronic insert.

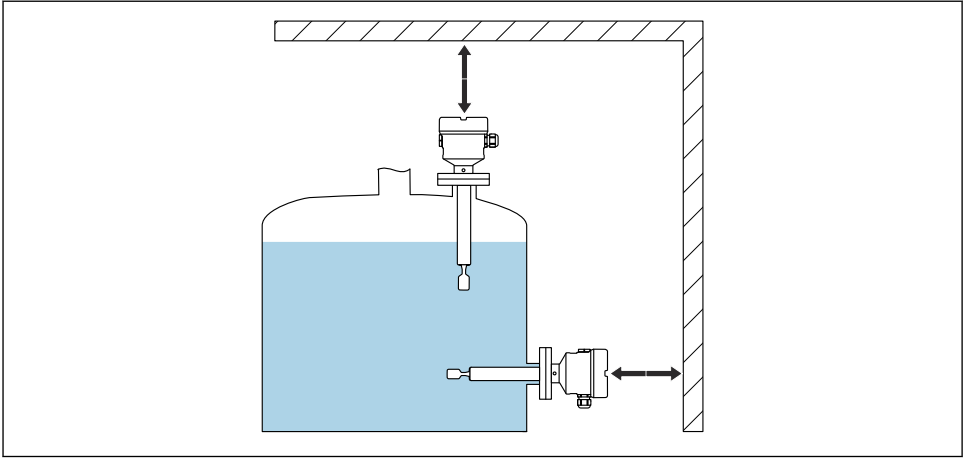

A0048474

6 Take clearance into consideration

### 5.1.6 Support the device

#### NOTICE

If the device is supported incorrectly, shocks and vibrations can damage the coated surface.

- ▶ Only use a support in conjunction with ECTFE or PFA plastic coating.
- ▶ Only use suitable supports.

Support the device in the event of severe dynamic load. Maximum lateral loading capacity of the pipe extensions and sensors: 75 Nm (55 lbf ft).

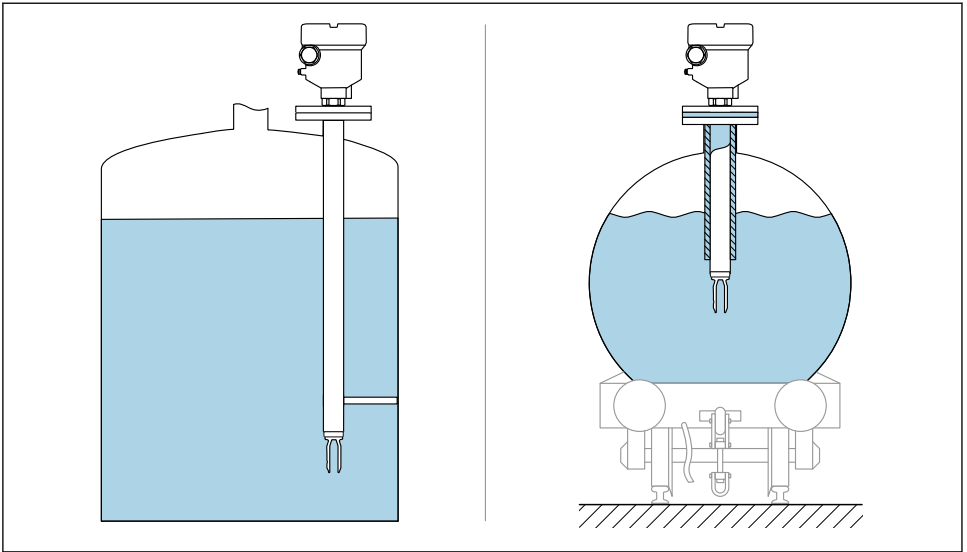

A0039742

7 Support in the event of dynamic load

## 5.2 Mounting the device

### 5.2.1 Required tool

- Open-ended wrench for securing the flange
- Allen key for housing locking screw

### 5.2.2 Installation

#### Aligning the tuning fork using the marking

The tuning fork can be aligned using the marking in such a way that the medium drains off easily and buildup is avoided.

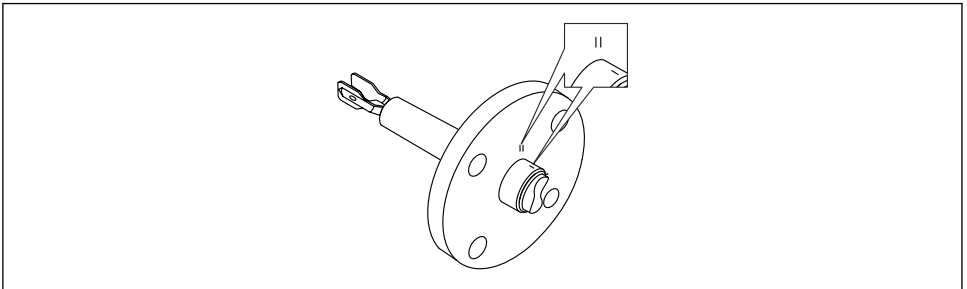

A0042207

8 Position of the tuning fork when installed horizontally in the vessel using the marking

## Installing the device in piping

### NOTICE

#### Incorrect alignment of the tuning fork

Vortices and eddies can falsify the measuring result.

- ▶ Align the tuning fork in the flow direction for internal fixtures in pipes or tanks with an agitator.
  - The flow velocity of the medium must not exceed 2 m/s (6.56 ft/s) during operation
  - Flow velocity > 2 m/s: Separate the tuning fork from the direct flow of media by using structural features such as a bypass or pipe expansion to reduce the flow velocity to max. 2 m/s (6.56 ft/s)
  - The flow will not be significantly impeded if the tuning fork is correctly aligned and the marking is pointing in the direction of flow.
  - A marking on the process connection indicates the position of the tuning fork. Threaded connection = dot on the hexagon head; flange = two lines on the flange. The marking is visible when installed.

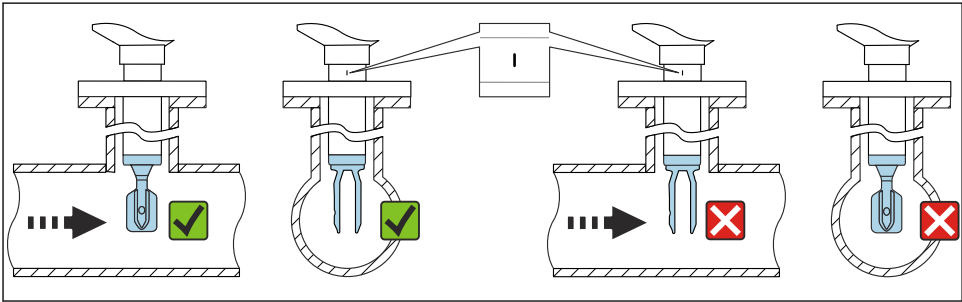

A0042208

9 Installation in pipes (take fork position and marking into consideration)



## Aligning the cable entry

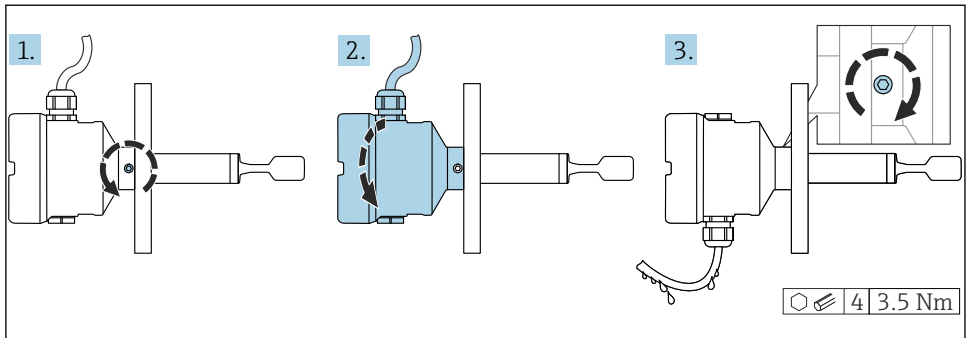

A0042214

### 10 Housing with external locking screw and drip loop

- i** Housings with locking screw:
- The housing can be turned and the cable aligned by turning the locking screw.
  - The locking screw is not tightened when the device is delivered.

1. Loosen the external locking screw (maximum 1.5 turns).
2. Turn the housing, align the cable entry.
  - ↳ Avoid moisture in the housing, provide a loop to allow moisture to drain off.
3. Tighten the external locking screw.

## 6 Electrical connection

### 6.1 Required tool

- Screwdriver for electrical connection
- Allen key for screw of cover lock

### 6.2 Connecting requirements

#### 6.2.1 Cover with securing screw

The cover is locked by a securing screw in devices for use in hazardous areas with certain explosion protection.

**NOTICE**

**If the securing screw is not positioned correctly, the cover cannot provide secure sealing.**

- ▶ Open the cover: slacken the screw of the cover lock with a maximum of 2 turns so that the screw does not fall out. Fit the cover and check the cover seal.
- ▶ Close the cover: screw the cover securely onto the housing, making sure that the securing screw is positioned correctly. There should not be any gap between the cover and housing.

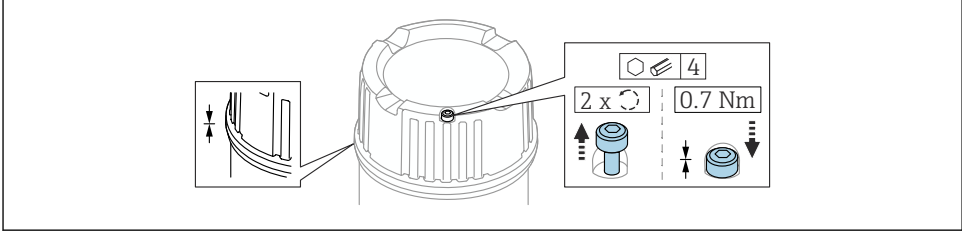

A0039520

 11 Cover with securing screw

### 6.2.2 Connecting protective earth (PE)

When the device is used in hazardous areas, it must always be included in the potential equalization of the system, irrespective of the operating voltage. This is possible by connecting to the inner or outer protective ground connection (PE).

## 6.3 Connecting the device



### Housing thread

The threads of the electronics and connection compartment can be coated with an anti-friction coating.

The following applies for all housing materials:

 **Do not lubricate the housing threads.**

### 6.3.1 2-wire density (electronic insert FEL60D) for density measurement

**NOTICE**

**Operation with other switching units is not permitted.**

Destruction of electronic components.

- ▶ Do not install the FEL60D electronic insert in devices that were originally used as point level switches.

### Terminal assignment

The output signal of the density sensor is based on pulse technology. With the aid of this signal, the fork frequency is constantly forwarded to the Density Computer FML621.

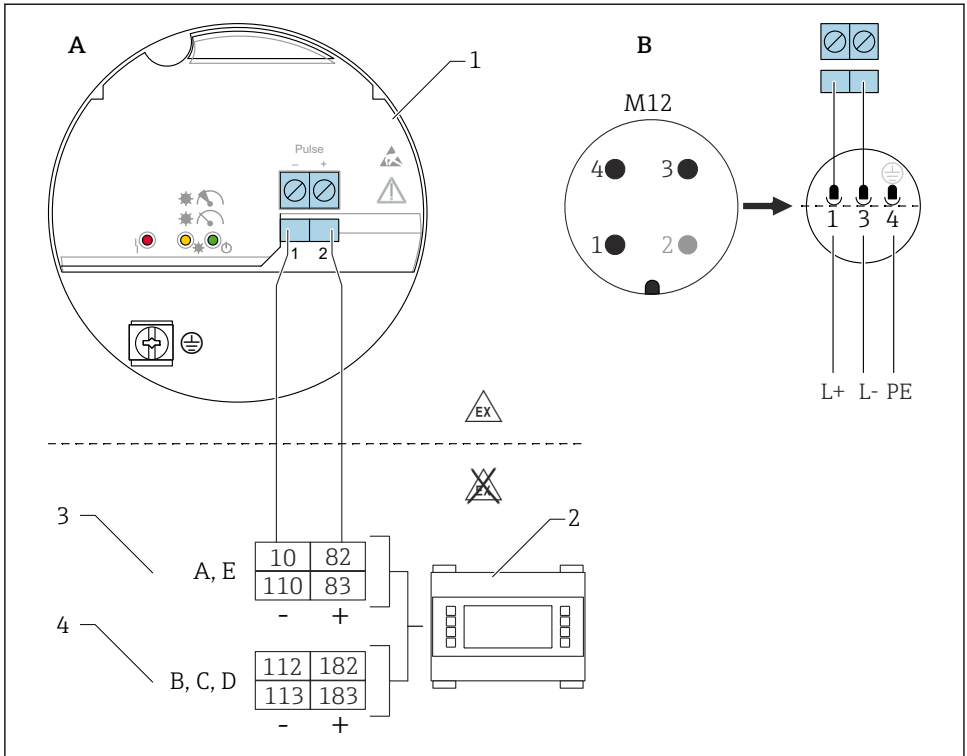

A0036059

**12** Connection diagram: electronic insert FEL60D connection to Density Computer FML621

- A Connection wiring with terminals
- B Connection wiring with M12 plug in housing as per EN61131-2 standard
- 1 Electronic insert FEL60D
- 2 Density Computer FML621
- 3 Slots A, E with extension cards (already installed in the basic unit)
- 4 Slots B, C, D with extension cards (optional)

### Supply voltage

$U = 24 V_{DC} \pm 15\%$ , only suitable for connecting to the Density Computer FML621



The device must be powered by a voltage supply categorized as "CLASS 2" or "SELV".

### Power consumption

$P < 160 \text{ mW}$

### Current consumption

$I < 10 \text{ mA}$

## Overvoltage protection

Overvoltage category I

### Adjustment

**There are 3 different types of adjustment:**

- **Standard adjustment (order configuration):**  
Two fork parameters are determined at the factory to describe the sensor characteristics and are provided in the calibration report with the product. These parameters must be transmitted to the Density Computer FML621.
- **Special adjustment (select in the Product Configurator):**  
Three fork parameters are determined at the factory to describe the sensor characteristics and are provided in the calibration report with the product. These parameters must be transmitted to the Density Computer FML621.  
This type of adjustment achieves an even higher level of accuracy.
- **Field adjustment:**  
With a field adjustment, the density determined by the user is transmitted to the FML621.

 All the necessary parameters of the Liquiphant Density are documented in the **adjustment report** and in the **sensor pass**.

The documents are included in the scope of delivery.

 Further information and the documentation currently available can be found on the Endress+Hauser website: [www.endress.com](http://www.endress.com) → Downloads.

### Density measurement

The Liquiphant Density measures the density of a liquid medium in pipes and tanks. The device is suitable for all Newtonian (purely viscous) fluids. In addition, the device is also suitable for use in hazardous areas.

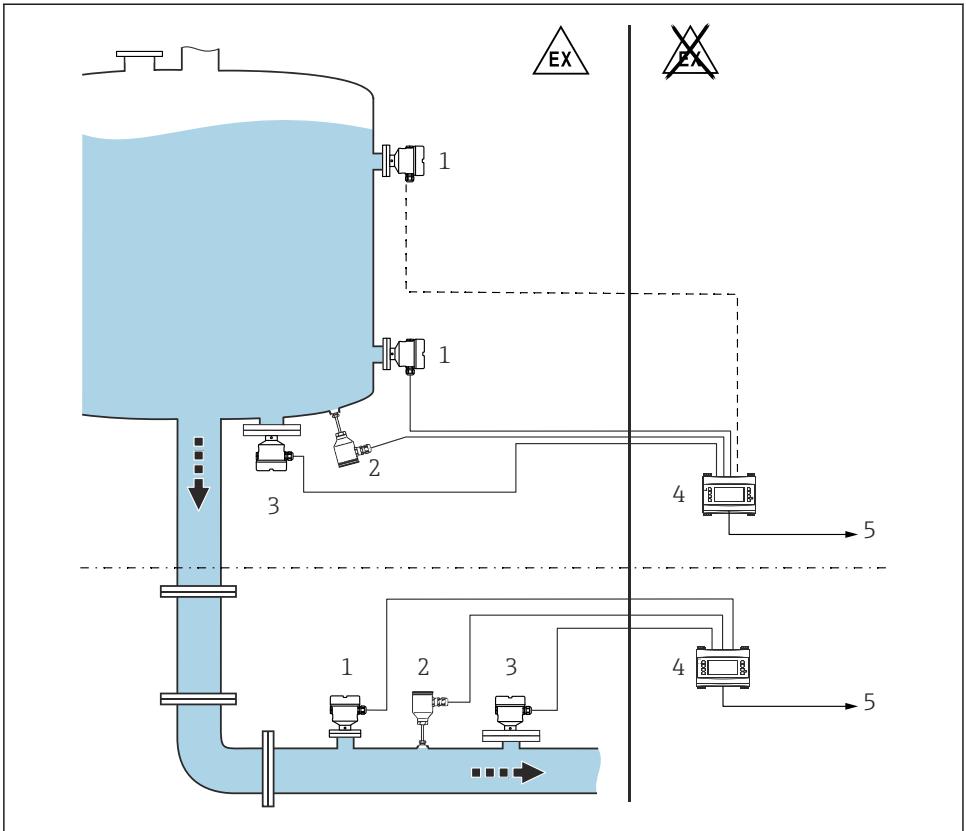

A0039632

### 13 Density measurement with Density Computer FML621

- 1 Liquiphant Density → Pulse output
- 2 Temperature sensor, e.g. 4 to 20 mA output
- 3 Pressure transmitter 4 to 20 mA output required for changes in pressure >6 bar
- 4 Liquiphant Density Computer FML621 with display and operating unit
- 5 PLC



The measurement can be affected by:

- air bubbles at the sensor
- unit not fully covered by the medium
- solid media buildup on the sensor
- high flow velocity in pipes
- severe turbulence in the pipe due to inlet and outlet runs that are too short
- corrosion of the fork
- non-Newtonian (not purely viscous) behavior of media

## 6.3.2 Connecting the cables

### Required tools

- Flat-blade screwdriver (0.6 mm x 3.5 mm) for terminals
- Suitable tool with width across flats AF24/25 (8 Nm (5.9 lbf ft)) for M20 cable gland

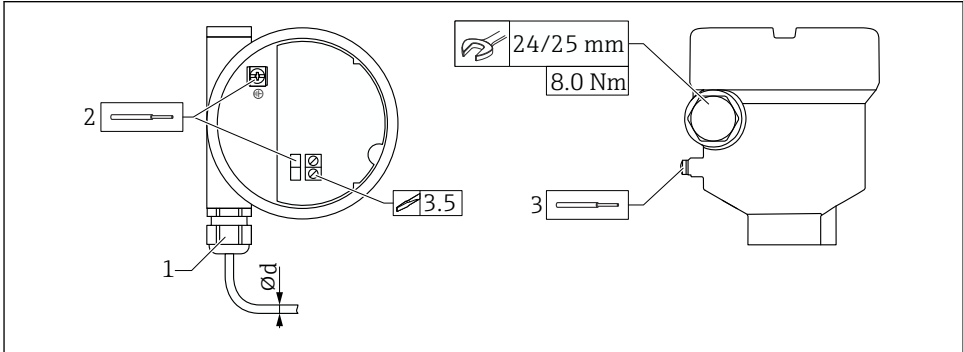

### 14 Example of coupling with cable entry, electronic insert with terminals

- 1 M20 coupling (with cable entry), example
  - 2 Conductor cross-section maximum  $2.5 \text{ mm}^2$  (AWG14), ground terminal on inside in housing + terminals on the electronics
  - 3 Conductor cross-section maximum  $4.0 \text{ mm}^2$  (AWG12), ground terminal on outside of the housing (example: plastic housing with outer protective ground connection (PE))
- Ød Nickel-plated brass 7 to 10.5 mm (0.28 to 0.41 in),  
 Plastic 5 to 10 mm (0.2 to 0.38 in),  
 Stainless steel 7 to 12 mm (0.28 to 0.47 in)

### **i** Pay attention to the following when using the M20 coupling

Following cable entry:

- Counter-tighten the coupling
- Tighten the union nut of the coupling with 8 Nm (5.9 lbf ft)
- Screw the enclosed coupling into the housing with 3.75 Nm (2.76 lbf ft)

## 7 Operation options

### 7.1 Overview of operation options

#### 7.1.1 Operating concept

Operation with the Density Computer FML621. For details, see documentation for the Density Computer FML621.

### 7.1.2 Elements on the electronic insert

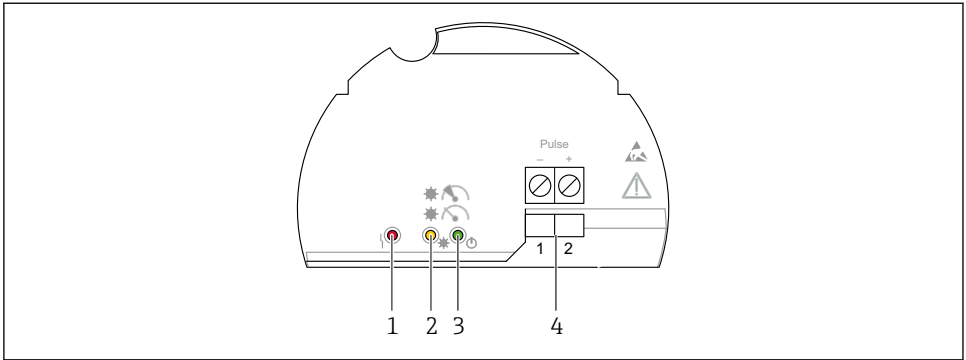

A0039683

15 Electronic insert FEL60D

- 1 LED red, for warning or alarm
- 2 LED yellow, stability of measurement
- 3 LED green, operational status (device is on)
- 4 Pulse output terminals

## 8 Commissioning

### 8.1 Function check

Before commissioning the measuring point, check whether the post-mounting and post-connection checks (checklist) have been performed, see the Operating Instructions.

### 8.2 Switching on the device

- ▶ Switch on
  - ↳ The green LED is lit and the yellow LED flashes 2-3 times

The measurement is stable if both LEDs (green and yellow) are then lit.



71624357

[www.addresses.endress.com](http://www.addresses.endress.com)

---