

Technical Information

Liquiphant FTL63

Vibronic



Point level switch for liquids specifically for the food and life sciences industries

Application

- Point level switch for all pumpable liquids, for minimum or maximum detection in vessels e.g. process tanks, storage tanks, and piping, even in hazardous areas
- Process temperature range: -50 to +150 °C (-58 to +302 °F)
- Pressures up to 64 bar (928 psi)
- Viscosities up to 10 000 mPa·s
- Ideal substitute for float switches; reliable function is not affected by flow, turbulence, air bubbles, foam, vibration, solids content or buildup

Advantages

- Easy commissioning with plug and play functionality
- Certified, hygienic design (3-A, EHEDG, ASME BPE)
- Proven conformity with materials standards, e.g. EC1935/2004, FDA, GB 4806, cGMP
- Heartbeat Technology via the free iOS/Android SmartBlue app
- With *Bluetooth*® wireless technology
- Optical process condition indication based on color change and bright LED display

Table of contents

About this document	4	DC connection, relay output (electronic insert FEL64 DC)	12
Symbols	4	Supply voltage	13
Function and system design	5	Power consumption	13
point level detection	5	Connectable load	13
Measuring principle	5	Behavior of output signal	13
Measuring system	5	Terminals	13
Dependability	5	Overvoltage protection	13
Input	5	Terminal assignment	13
Measured variable	5	Behavior of switch output and signaling	14
Measuring range	5	PFM output (electronic insert FEL67)	14
Output	6	Supply voltage	14
Output and input variants	6	Power consumption	14
Output signal	6	Behavior of output signal	14
Ex connection data	6	Terminals	14
2-wire AC (electronic insert FEL61)	7	Overvoltage protection	14
Supply voltage	7	Terminal assignment	15
Power consumption	7	Connection cable	15
Current consumption	7	Behavior of switch output and signaling	16
Connectable load	7	2-wire NAMUR > 2.2 mA/ < 1.0 mA (electronic insert FEL68)	16
Behavior of output signal	7	Supply voltage	16
Terminals	7	Power consumption	16
Overvoltage protection	7	Connection data interface	16
Terminal assignment	7	Behavior of output signal	16
Behavior of switch output and signaling	8	Terminals	17
3-wire DC-PNP (electronic insert FEL62)	9	Overvoltage protection	17
Supply voltage	9	Terminal assignment	17
Power consumption	9	Behavior of switch output and signaling	17
Current consumption	9	Electronic insert FEL68 with Bluetooth module	17
Load current	9	LED module VU120 (optional)	18
Capacitance load	9	Supply voltage	18
Residual current	9	Power consumption	18
Residual voltage	9	Current consumption	18
Behavior of output signal	9	Signaling of operational status	18
Terminals	9	Bluetooth module and Heartbeat Technology	18
Overvoltage protection	9	Bluetooth module VU121 (optional)	18
Terminal assignment	10	Heartbeat Technology	19
Behavior of switch output and signaling	10	Performance characteristics	20
Universal current connection with relay output (electronic insert FEL64)	10	Reference operating conditions	20
Supply voltage	11	Take switch point into consideration	20
Power consumption	11	Maximum measured error	20
Connectable load	11	Hysteresis	20
Behavior of output signal	11	Non-repeatability	20
Terminals	11	Influence of the process temperature	20
Overvoltage protection	11	Influence of the process pressure	20
Terminal assignment	12	Influence of the density of the process medium (at room temperature and normal pressure)	21
Behavior of switch output and signaling	12	Mounting	21
		Mounting location, orientation	21
		Installation instructions	22

Aligning the tuning fork using the marking	24	Order information	46
Installing the device in piping	24	TAG	46
Aligning the cable entry	24	Test reports, declarations and inspection certificates	47
Special mounting instructions	25		
Environment	26	Application packages	47
Ambient temperature range	26	Heartbeat Technology module	47
Storage temperature	27	Heartbeat Verification	48
Humidity	27	Proof testing for SIL/WHG devices	48
Operating altitude	27		
Climate class	27	Accessories	48
Degree of protection	27	LED module VU120 (optional)	48
Vibration resistance	28	Bluetooth module VU121 (optional)	48
Shock resistance	28	Protective cover for aluminum dual compartment housing	49
Mechanical load	28	Protective cover for aluminum single compartment housing	49
Pollution degree	28	Weld-in adapter	49
Electromagnetic compatibility (EMC)	28	Test magnet	50
		M12 socket	50
Process	28		
Process temperature range	28	Documentation	50
Thermal shock	28	Standard documentation	51
Process pressure range	28	Supplementary device-dependent documentation	51
Process pressure range of the sensors	29		
Overpressure limit	29	Registered trademarks	51
Density	29		
Viscosity	29		
Pressure tightness	29		
Solids contents	29		
Mechanical construction	29		
Design, dimensions	29		
Dimensions	30		
Weight	39		
Materials	40		
Surface roughness	40		
User interface	41		
Operation concept	41		
Onsite operation	41		
Local display	42		
Remote operation	43		
Certificates and approvals	44		
CE mark	44		
RCM marking	44		
Ex approval	44		
Material compliance for contact with food	44		
Hygienic design requirements	44		
Compliance with requirements derived from cGMP	45		
General material compliance	45		
Overfill protection	45		
Functional safety	45		
Radio approval	45		
CRN approval	45		
Service	45		
Test, certificate, declaration	45		
TSE (BSE) compliance (ADI free - Animal Derived Ingredients)	46		
Pressure Equipment Directive	46		
Process seal as per ANSI/ISA 12.27.01	46		
EAC conformity	46		
ASME B 31.3/31.1	46		

About this document

Symbols

Safety symbols



This symbol alerts you to a dangerous situation. Failure to avoid this situation will result in serious or fatal injury.



This symbol alerts you to a dangerous situation. Failure to avoid this situation can result in serious or fatal injury.



This symbol alerts you to a dangerous situation. Failure to avoid this situation can result in minor or medium injury.



This symbol contains information on procedures and other facts which do not result in personal injury.

Electrical symbols

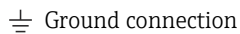

Grounded clamp, which is grounded via a grounding system.



Ground terminals, which must be grounded prior to establishing any other connections. The ground terminals are located on the inside and outside of the device.

Symbols for certain types of information



Procedures, processes or actions that are permitted.



Procedures, processes or actions that are forbidden.



Indicates additional information

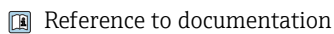

Reference to documentation

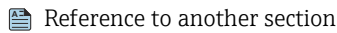

Reference to another section



Series of steps

Symbols in graphics

A, B, C ... View

1, 2, 3 ... Item numbers



Hazardous area

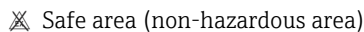

Safe area (non-hazardous area)

Communication-specific symbols



Wireless data transmission between devices over a short distance.

Function and system design

point level detection

Maximum or minimum detection for liquids in tanks or pipes in all industries. Suitable for leakage monitoring, pump dry-running protection or overflow prevention, for example .

Specific versions are suitable for use in hazardous areas.

The point level switch differentiates between the "covered" and "not covered" conditions.

Depending on the MIN (minimum detection) or MAX (maximum detection) modes, there are two possibilities in each case: OK status and demand mode.

OK status

- In MIN mode, the fork is covered, e.g. Pump dry running protection
- In MAX mode, the fork is not covered e.g. overflow prevention

Demand mode

- In MIN mode, the fork is not covered e.g. pump dry running protection
- In MAX mode, the fork is covered e.g. overflow prevention

Measuring principle

The sensor's tuning fork vibrates at its intrinsic frequency. As soon as the liquid covers the tuning fork, the vibration frequency decreases. The change in frequency causes the point level switch to switch.

Measuring system

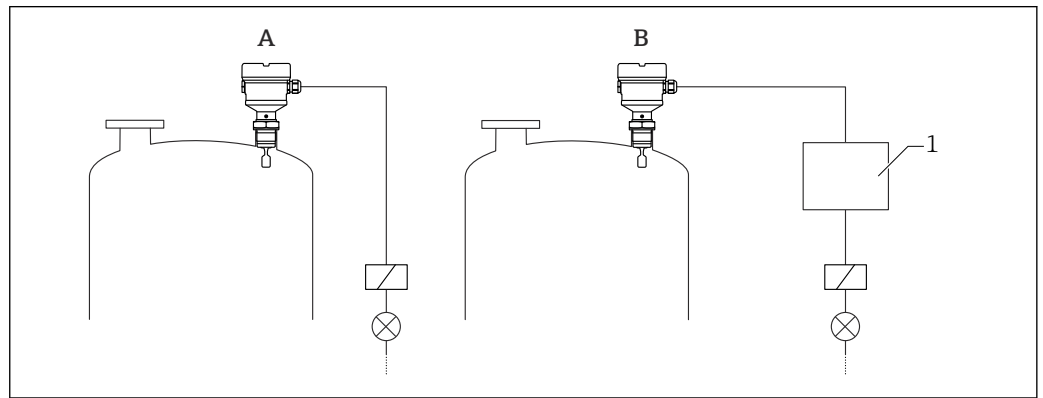

1 Example of a measuring system

A Device for direct connection of a load

B Device for connection to a separate switching unit or PLC

1 Switching unit, PLC etc.

Dependability

Device-specific IT security

The device settings and the diagnostic data can be read out via Bluetooth. Device settings cannot be changed via Bluetooth.

Input

Measured variable

Level (point level), MAX or MIN safety

Measuring range

Depends on the installation location and the pipe extension ordered
Maximum sensor length 3 m (10 ft)

Output

Output and input variants	<p>Electronic inserts</p> <p>2-wire AC (FEL61)</p> <ul style="list-style-type: none"> ▪ Two-wire AC version ▪ Switches the load directly into the power supply circuit via an electronic switch <p>3-wire DC-PNP (FEL62)</p> <ul style="list-style-type: none"> ▪ Three-wire direct current version ▪ Switches the load via the transistor (PNP) and separate connection, e.g. in conjunction with programmable logical controllers (PLC) ▪ Ambient temperature -60 °C (-76 °F), optionally available to order Low-temperature electronic inserts are marked LT <p>Universal current connection, relay output (FEL64)</p> <ul style="list-style-type: none"> ▪ Switches the loads via 2 potential-free change-over contacts ▪ Ambient temperature -60 °C (-76 °F), optionally available to order Low-temperature electronic inserts are marked LT <p>Direct current connection, relay output (FEL64DC)</p> <ul style="list-style-type: none"> ▪ Switches the load via 2 potential-free changeover contacts ▪ Ambient temperature -60 °C (-76 °F), optionally available to order Low-temperature electronic inserts are marked LT <p>PFM output (FEL67)</p> <ul style="list-style-type: none"> ▪ For separate switching device (Nivotester FTL325P, FTL375P) ▪ PFM signal transmission; current pulses are superimposed on the power supply along the two-wire cabling ▪ Ambient temperature -50 °C (-58 °F), optionally available to order The low-temperature electronic inserts are marked LT <p>2-wire NAMUR $> 2.2\text{ mA}/< 1.0\text{ mA}$ (FEL68)</p> <ul style="list-style-type: none"> ▪ For separate switching unit, e.g. Nivotester FTL325N ▪ Signal transmission H-L edge 2.2 to 3.8/0.4 to 1.0 mA as per IEC 60917-5-6 (NAMUR) on two-wire cable ▪ Ambient temperature -50 °C (-58 °F), optionally available to order Low-temperature electronic inserts are marked LT
Output signal	<p>Switch output</p> <p>The following default switching delay times can be ordered for electronic inserts FEL61, FEL62, FEL64, FEL64DC, FEL67 and FEL68:</p> <ul style="list-style-type: none"> ▪ 0.5 s when the tuning fork is covered and 1.0 s when it is uncovered (factory setting) ▪ 0.25 s when the tuning fork is covered and 0.25 s when it is uncovered ▪ 1.5 s when the tuning fork is covered and 1.5 s when it is uncovered ▪ 5.0 s when the tuning fork is covered and 5.0 s when it is uncovered <p>COM interface</p> <p>For connecting to modules VU120 or VU121 (no modifying effect)</p> <p><i>Bluetooth® wireless technology (optional)</i></p> <p>The device has a Bluetooth® wireless technology interface. Device data and diagnostic data can be read out using the free "SmartBlue" app.</p>
Ex connection data	<p>See safety instructions (XA): All data relating to explosion protection are provided in separate Ex documentation and are available from the Downloads area of the Endress+Hauser website. The Ex documentation is supplied as standard with all devices approved for use in explosion hazardous areas.</p>

2-wire AC (electronic insert FEL61)

- Two-wire AC version
- Switches the load directly into the power supply circuit via an electronic switch; always connect in series with a load
- Functional testing without level change
A functional test can be performed on the device using the test button on the electronic insert.

Supply voltage	<p>$U = 19 \text{ to } 253 \text{ V}_{AC}, 50 \text{ Hz}/60 \text{ Hz}$</p> <p>Residual voltage when switched through: typically 12 V</p> <p> Observe the following as per IEC/EN61010-1: Provide a suitable circuit breaker for the device, and limit the current to 1 A, e.g. by installing a 1 A fuse (slow-blow) in the phase (not the neutral conductor) of the supply circuit.</p>
Power consumption	$S \leq 2 \text{ VA}$
Current consumption	<p>Residual current when blocked: $I \leq 3.8 \text{ mA}$</p> <p>The red LED flashes in the event of an overload or short-circuit. Check for an overload or short-circuit every 5 s. The test is deactivated after 60 s.</p>
Connectable load	<ul style="list-style-type: none"> ■ Load with a minimum holding power/rated power of 2.5 VA at 253 V (10 mA) or 0.5 VA at 24 V (20 mA) ■ Load with a maximum holding power/rated power of 89 VA at 253 V (350 mA) or 8.4 VA at 24 V (350 mA) ■ With overload and short-circuit protection
Behavior of output signal	<ul style="list-style-type: none"> ■ OK status: load on (switched through) ■ Demand mode: load off (blocked) ■ Alarm: load off (blocked)
Terminals	Terminals for cable cross-section up to 2.5 mm ² (14 AWG). Use ferrules for the wires.
Overvoltage protection	Overvoltage category II
Terminal assignment	Always connect an external load. The electronic insert has integrated short-circuit protection.

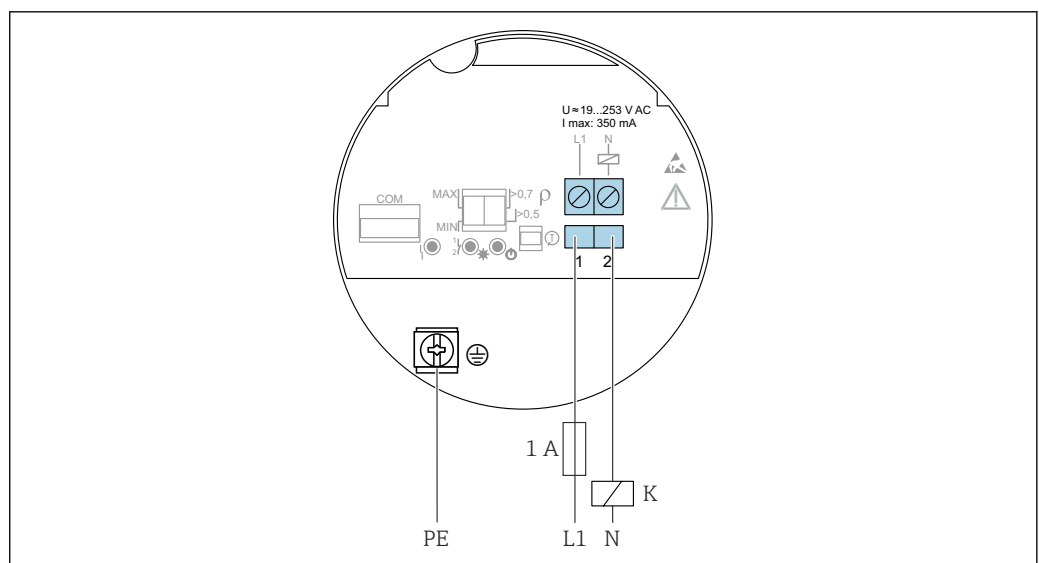

 2 2-wire AC, electronic insert FEL61

A0036060

Behavior of switch output and signaling

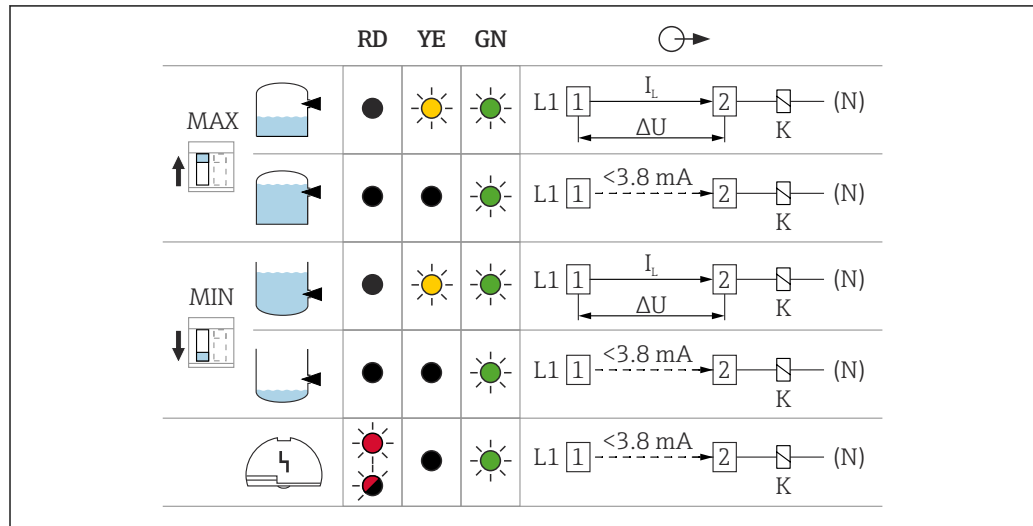

A0031901

3 Behavior of switch output and signaling, electronic insert FEL61

MAX DIP switch for setting MAX safety mode

MIN DIP switch for setting MIN safety mode

RD LED red for warning or alarm

YE LED yellow, switch status

GN LED green, operational status, device on

I_L Load current switched through

Selection tool for relays

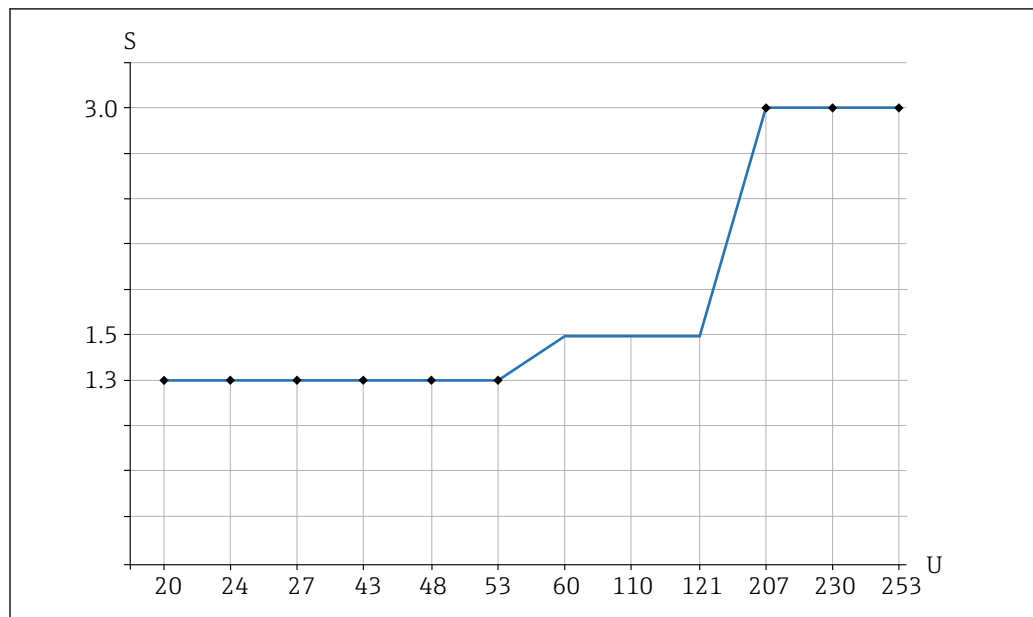

A0042052

4 Recommended minimum holding power/rated power for load

S Holding power/rated power in [VA]

U Operating voltage in [V]

AC mode

- Operating voltage: 24 V, 50 Hz/60 Hz
- Holding power/rated power: > 0.5 VA, < 8.4 VA
- Operating voltage: 110 V, 50 Hz/60 Hz
- Holding power/rated power: > 1.1 VA, < 38.5 VA
- Operating voltage: 230 V, 50 Hz/60 Hz
- Holding power/rated power: > 2.3 VA, < 80.5 VA

3-wire DC-PNP (electronic insert FEL62)

- Three-wire DC version
- Preferably in conjunction with programmable logic controllers (PLC), DI modules as per EN 61131-2. Positive signal at switch output of electronics module (PNP)
- Functional testing without level change
A functional test can be performed on the device using the test button on the electronic insert or using the test magnet (can be ordered as an option) with the housing closed.

Supply voltage



WARNING

Failure to use the prescribed power unit.

Risk of potentially life-threatening electric shock!

- ▶ The FEL62 may only be powered by devices with safe galvanic isolation, as per IEC 61010-1.

$U = 10 \text{ to } 55 \text{ V}_{\text{DC}}$



The device must be powered by a voltage supply categorized as "CLASS 2" or "SELV".



Comply with the following according to IEC/EN61010-1: provide a suitable circuit breaker for the device and limit the current to 500 mA, e.g. by installing a 0.5 A fuse (slow-blow) in the power supply circuit.

Power consumption

$P \leq 0.5 \text{ W}$

Current consumption

$I \leq 10 \text{ mA}$ (without load)

The red LED flashes in the event of an overload or short-circuit. Check for an overload or short-circuit every 5 s.

Load current

$I \leq 350 \text{ mA}$ with overload and short-circuit protection

Capacitance load

$C \leq 0.5 \text{ }\mu\text{F}$ at 55 V, $C \leq 1.0 \text{ }\mu\text{F}$ at 24 V

Residual current

$I < 100 \text{ }\mu\text{A}$ (for blocked transistor)

Residual voltage

$U < 3 \text{ V}$ (for switched through transistor)

Behavior of output signal

- OK status: switched through
- Demand mode: blocked
- Alarm: blocked

Terminals

Terminals for cable cross-section up to 2.5 mm^2 (14 AWG). Use ferrules for the wires.

Overvoltage protection

Overvoltage category I

Terminal assignment

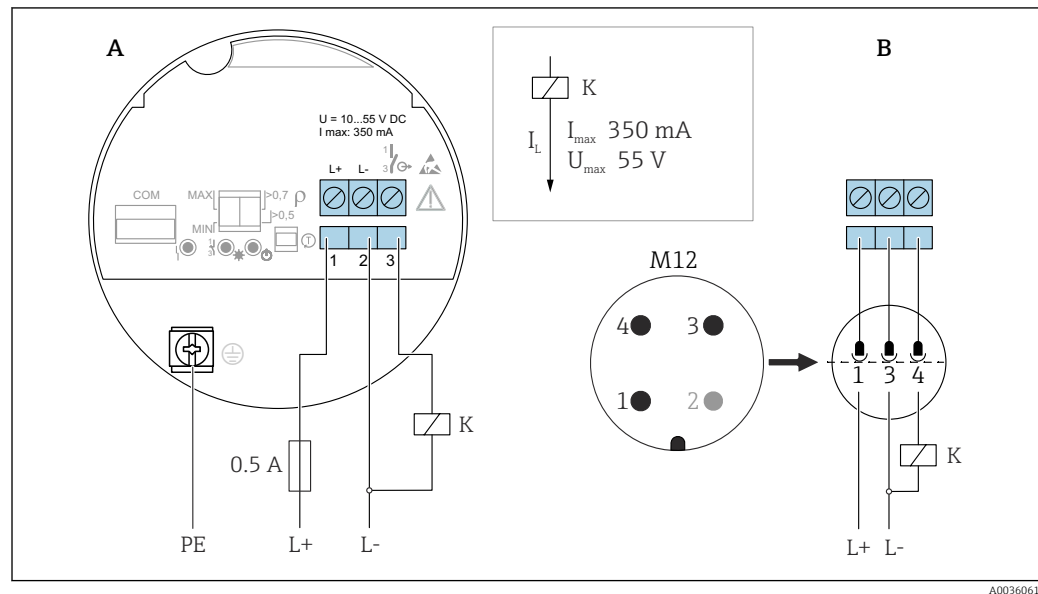

5 3-wire DC-PNP, electronic insert FEL62

A Connection wiring with terminals

B Connection wiring with M12 plug in housing according to EN61131-2 standard

Behavior of switch output and signaling

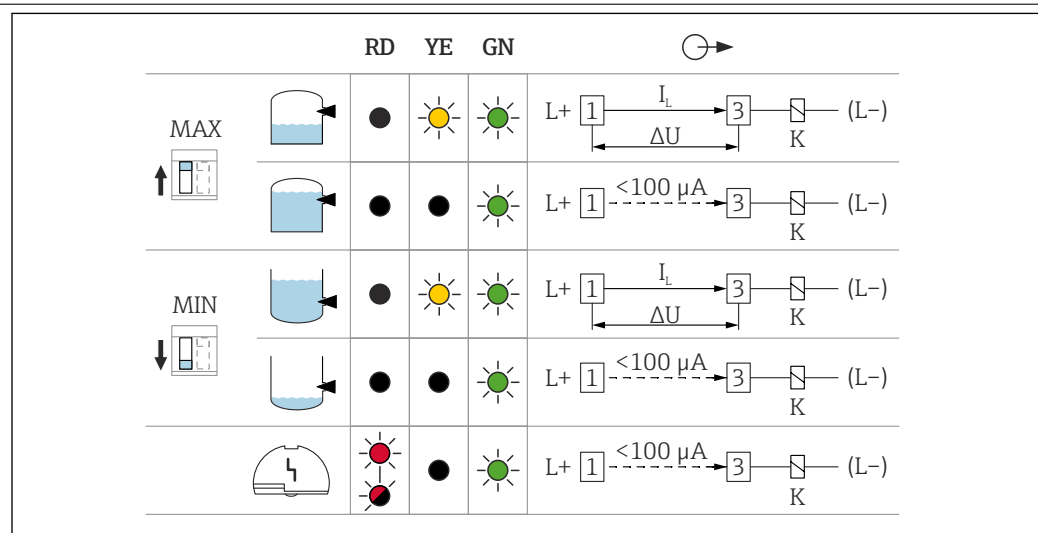

6 Behavior of switch output and signaling, electronic insert FEL62

MAX DIP switch for setting MAX safety mode

MIN DIP switch for setting MIN safety mode

RD LED red for warning or alarm

YE LED yellow, switch status

GN LED green, operational status, device on

I_L Load current switched through



Universal current connection with relay output (electronic insert FEL64)

- Switches the loads via 2 potential-free change-over contacts
- 2 galvanically isolated change-over contacts (DPDT), both change-over contacts switch simultaneously
- Functional testing without level change. A functional test can be performed on the device using the test button on the electronic insert or using the test magnet (can be ordered as an option) with the housing closed.

⚠ WARNING

An error at the electronic insert can cause the permitted temperature for touch-safe surfaces to be exceeded. This presents a risk of burns.

- ▶ Do not touch the electronics in the event of an error!

Supply voltage	<p>$U = 19 \text{ to } 253 \text{ V}_{AC}, 50 \text{ Hz}/60 \text{ Hz} / 19 \text{ to } 55 \text{ V}_{DC}$</p> <p> Comply with the following according to IEC/EN61010-1: provide a suitable circuit breaker for the device and limit the current to 500 mA, e.g. by installing a 0.5 A fuse (slow-blow) in the power supply circuit.</p>
Power consumption	$S < 25 \text{ VA}, P < 1.3 \text{ W}$
Connectable load	<p>Loads switched via 2 potential-free changeover contacts (DPDT)</p> <ul style="list-style-type: none"> ▪ $I_{AC} \leq 6 \text{ A}, U \sim \leq \text{AC } 253 \text{ V}; P \sim \leq 1500 \text{ VA}, \cos \varphi = 1, P \sim \leq 750 \text{ VA}, \cos \varphi > 0.7$ ▪ $I_{DC} \leq 6 \text{ A to DC } 30 \text{ V}, I_{DC} \leq 0.2 \text{ A to } 125 \text{ V}$ <p> Additional restrictions for the connectable load depend on the selected approval. Pay attention to the information in the Safety Instructions (XA).</p> <p>According to IEC 61010, the following applies: total voltage from relay outputs and power supply $\leq 300 \text{ V}$.</p> <p>Use electronic insert FEL62 DC PNP for small DC load currents, e.g. for connection to a PLC.</p> <p>Relay contact material: silver/nickel AgNi 90/10</p> <p>When connecting a device with high inductance, provide a spark suppressor to protect the relay contact. A fine-wire fuse (depending on the connected load) protects the relay contact in the event of a short-circuit.</p> <p>Both relay contacts switch simultaneously.</p>
Behavior of output signal	<ul style="list-style-type: none"> ▪ OK status: relay energized ▪ Demand mode: relay de-energized ▪ Alarm: relay de-energized
Terminals	Terminals for cable cross-section up to 2.5 mm^2 (14 AWG). Use ferrules for the wires.
Overvoltage protection	Overvoltage category II

Terminal assignment

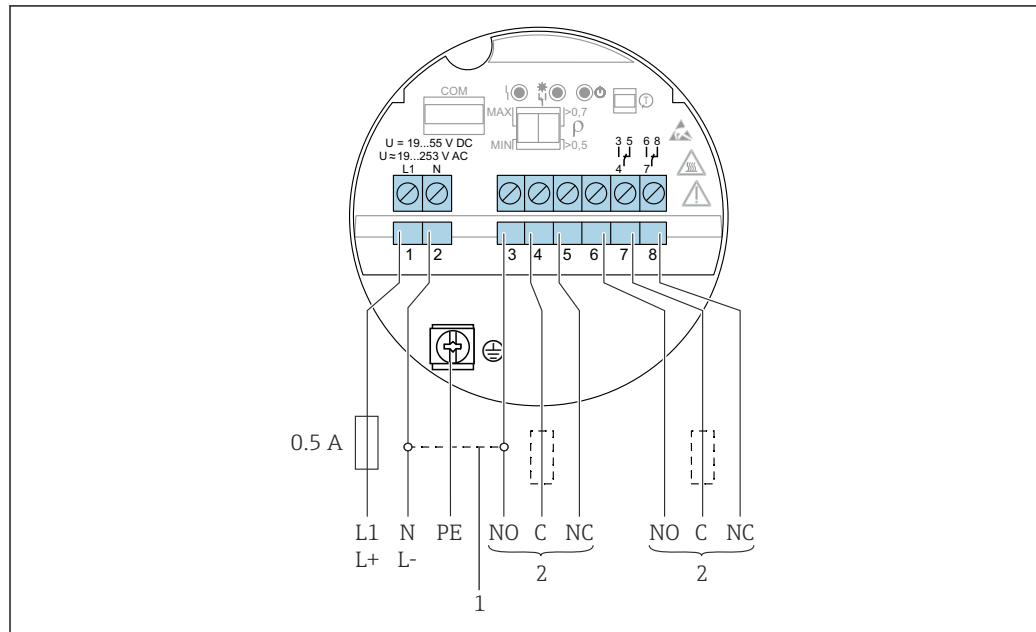

7 Universal current connection with relay output, electronic insert FEL64

- 1 When bridged, the relay output works with NPN logic
- 2 Connectable load

Behavior of switch output and signaling

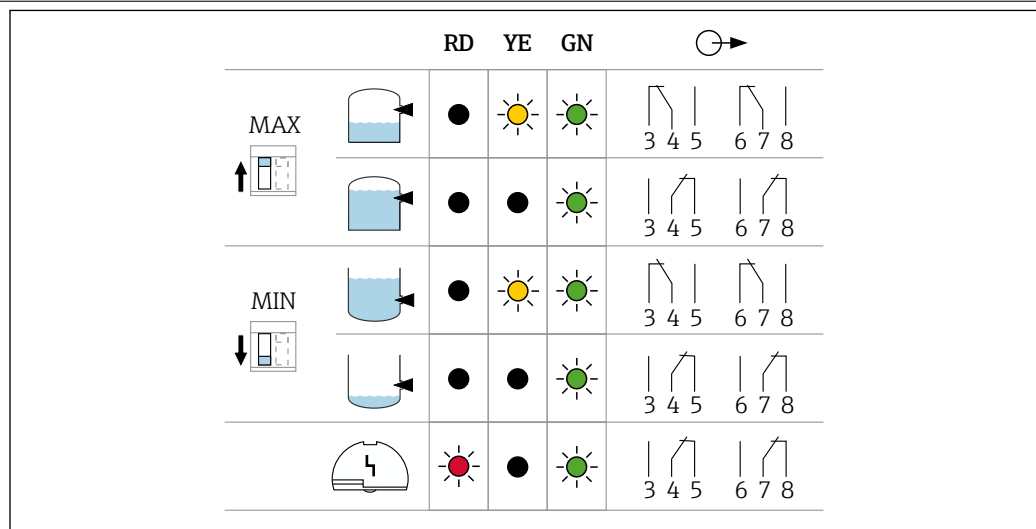

8 Behavior of switch output and signaling, electronic insert FEL64

MAX DIP switch for setting MAX safety mode

MIN DIP switch for setting MIN safety mode

RD LED red for alarm



YE LED yellow, switch status

GN LED green, operational status, device on

DC connection, relay output (electronic insert FEL64 DC)

- Switches the loads via 2 potential-free change-over contacts
- 2 galvanically isolated change-over contacts (DPDT), both change-over contacts switch simultaneously
- Functional testing without level change. Functional testing of the entire device can be performed using the test button on the electronic insert or with the test magnet (can be ordered as an option) with the housing closed.

Supply voltage $U = 9 \text{ to } 20 V_{DC}$

-  The device must be powered by a voltage supply categorized as "CLASS 2" or "SELV".
-  Comply with the following according to IEC/EN61010-1: provide a suitable circuit breaker for the device and limit the current to 500 mA, e.g. by installing a 0.5 A fuse (slow-blow) in the power supply circuit.

Power consumption $P < 1.0 \text{ W}$

Connectable load Loads switched via 2 potential-free change-over contacts (DPDT)

- $I_{AC} \leq 6 \text{ A}$, $U \sim \leq AC 253 \text{ V}$; $P \sim \leq 1500 \text{ VA}$, $\cos \varphi = 1$, $P \sim \leq 750 \text{ VA}$, $\cos \varphi > 0.7$
- $I_{DC} \leq 6 \text{ A}$ to DC 30 V, $I_{DC} \leq 0.2 \text{ A}$ to 125 V

 Additional restrictions for the connectable load depend on the selected approval. Pay attention to the information in the Safety Instructions (XA).

According to IEC 61010, the following applies: Total voltage from relay outputs and power supply $\leq 300 \text{ V}$

Electronic insert FEL62 DC PNP preferred for small DC load currents, e.g. connection to a PLC.

Relay contact material: silver/nickel AgNi 90/10

When connecting a device with high inductance, provide spark quenching to protect the relay contact. A fine-wire fuse (depending on the connected load) protects the relay contact in the event of a short-circuit.

Behavior of output signal

- OK status: relay energized
- Demand mode: relay de-energized
- Alarm: relay de-energized

Terminals Terminals for cable cross-section up to 2.5 mm² (14 AWG). Use ferrules for the wires.

Overvoltage protection Overvoltage category I



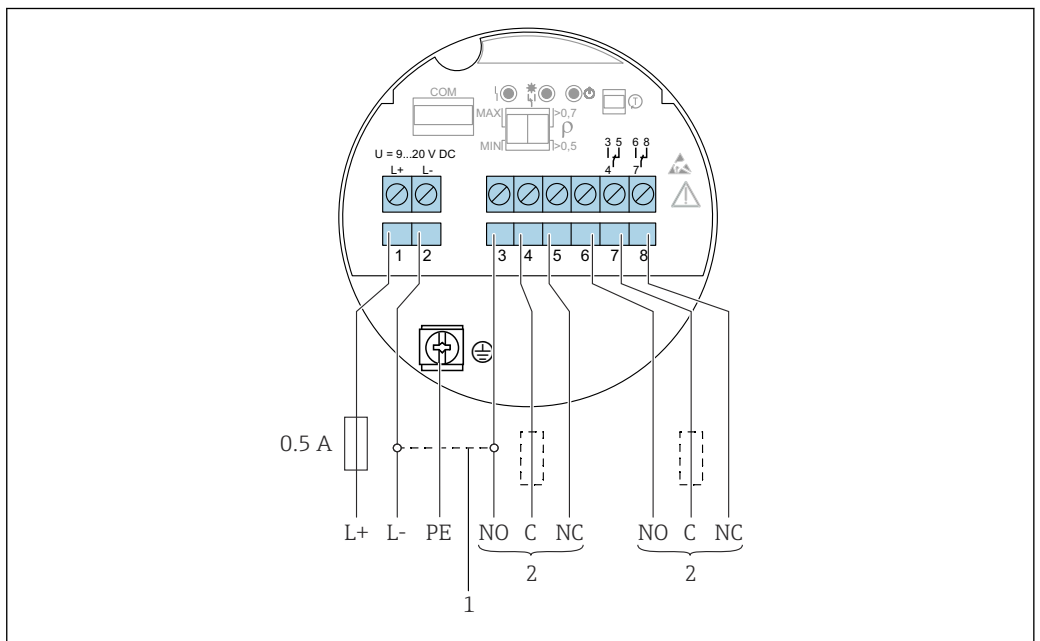

















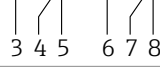



Terminal assignment

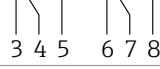

 9 DC connection with relay output, electronic insert FEL64 DC

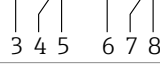
- 1 When bridged, the relay output works with NPN logic
- 2 Connectable load

Behavior of switch output and signaling

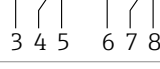
		RD	YE	GN	
MAX 					
					
MIN 					
					
					

A0039513

 10 Behavior of switch output and signaling, electronic insert FEL64 DC

MAX DIP switch for setting MAX safety mode

MIN DIP switch for setting MIN safety mode

RD LED red for alarm

YE LED yellow, switch status

GN LED green, operational status, device on

PFM output (electronic insert FEL67)

- For connection to Endress+Hauser Nivotester switching units FTL325P and FTL375P
- PFM signal transmission; pulse frequency modulation, superimposed on the power supply along the two-wire cabling
- Functional testing without level change:
 - A functional test can be performed on the device using the test button on the electronic insert.
 - The functional test can also be prompted by disconnecting the supply voltage or triggered directly by the Nivotester FTL325P and FTL375P switching unit.

Supply voltage

$U = 9.5$ to 12.5 V_{DC}

 The device must be powered by a voltage supply categorized as "CLASS 2" or "SELV".

 Comply with the following according to IEC/EN61010-1: provide a suitable circuit breaker for the device.

Power consumption

$P \leq 150$ mW with Nivotester FTL325P or FTL375P

Behavior of output signal

- OK status: MAX operating mode 150 Hz, MIN operating mode 50 Hz
- Demand mode: MAX operating mode 50 Hz, MIN operating mode 150 Hz
- Alarm: MAX/MIN operating mode 0 Hz

Terminals

Terminals for cable cross-section up to 2.5 mm² (14 AWG). Use ferrules for the wires.

Overvoltage protection

Overvoltage category I

Terminal assignment

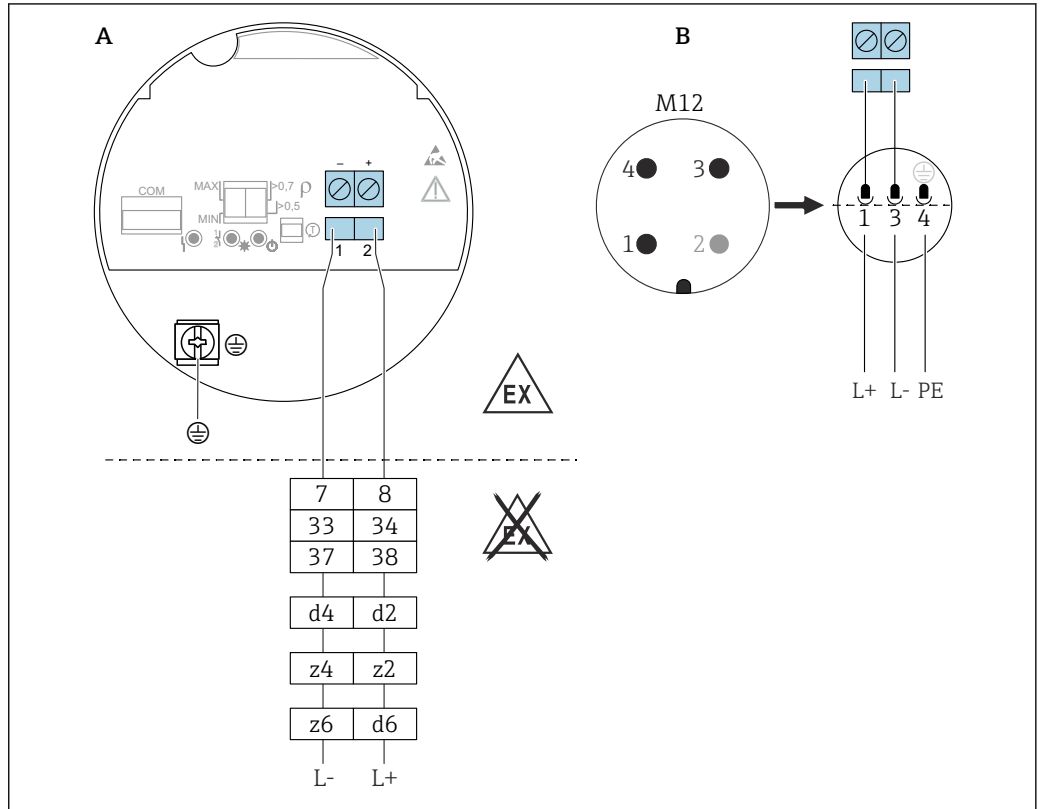

A0036065

11 PFM output, electronic insert FEL67

A Connection wiring with terminals

B Connection wiring with M12 plug in housing according to EN61131-2 standard

7/ 8: Nivotester FTL325P 1 CH, FTL325P 3 CH input 1

33/ 34: Nivotester FTL325P 3 CH input 2

37/ 38: Nivotester FTL325P 3 CH input 3

d4/ d2: Nivotester FTL375P input 1

z4/ z2: Nivotester FTL375P input 2

z6/ d6: Nivotester FTL375P input 3

Connection cable

- Maximum cable resistance: 25 Ω per core
- Maximum cable capacitance: < 100 nF
- Maximum cable length: 1000 m (3 281 ft)

Behavior of switch output and signaling

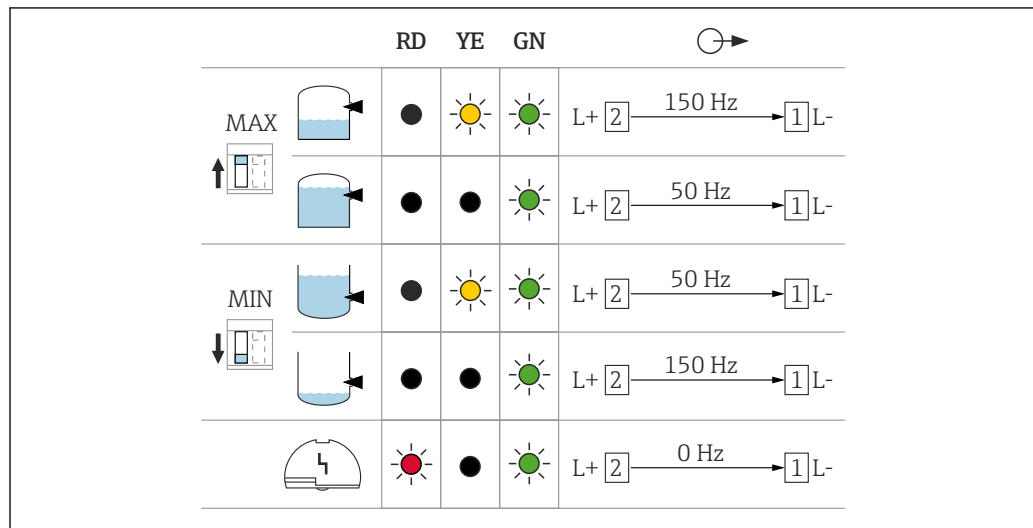

A0037696

12 Switching behavior and signaling, electronic insert FEL67

MAX DIP switch for setting MAX safety mode

MIN DIP switch for setting MIN safety mode

RD LED red for alarm

YE LED yellow, switch status

GN LED green, operational status, device on

i The switches for MAX/MIN on the electronic insert and the FTL325P switching unit must be set according to the application. Only then is it possible to perform the functional test correctly.

2-wire NAMUR > 2.2 mA/ < 1.0 mA (electronic insert FEL68)

- To connect to isolating amplifiers according to NAMUR (IEC 60947-5-6), e.g. Nivotester FTL325N from Endress+Hauser
- To connect to isolating amplifiers of third-party suppliers according to NAMUR (IEC 60947-5-6), a permanent power supply for the electronic insert FEL68 must be ensured
- Signal transmission H-L edge 2.2 to 3.8 mA/0.4 to 1.0 mA according to NAMUR (IEC 60947-5-6) on two-wire cabling
- Functional testing without level change. A functional test can be performed on the device using the test button on the electronic insert or using the test magnet (can be ordered as an option) with the housing closed.
The functional test can also be triggered by interrupting the supply voltage or activated directly from the Nivotester FTL325N.

Supply voltage

$U = 8.2 V_{DC} \pm 20\%$

i The device must be powered by a voltage supply categorized as "CLASS 2" or "SELV".

i Comply with the following according to IEC/EN61010-1: provide a suitable circuit breaker for the device.

Power consumption

NAMUR IEC 60947-5-6

< 6 mW with $I < 1 \text{ mA}$; < 38 mW with $I = 3.5 \text{ mA}$

Connection data interface

NAMUR IEC 60947-5-6

Behavior of output signal

- OK status: output current 2.2 to 3.8 mA
- Demand mode: output current 0.4 to 1.0 mA
- Alarm: output current < 1.0 mA

Terminals Terminals for cable cross-section up to 2.5 mm² (14 AWG). Use ferrules for the wires.

Overvoltage protection Overvoltage category I

Terminal assignment

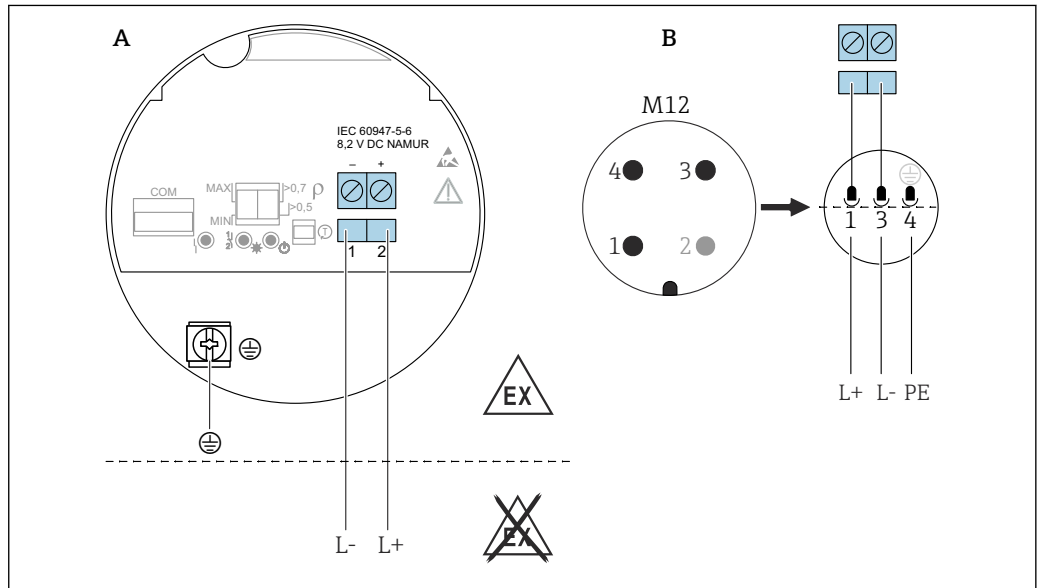

13 2-wire NAMUR $\geq 2.2 \text{ mA} / \leq 1.0 \text{ mA}$, electronic insert FEL68

A Connection wiring with terminals

B Connection wiring with M12 plug in housing according to EN61131-2 standard

Behavior of switch output and signaling

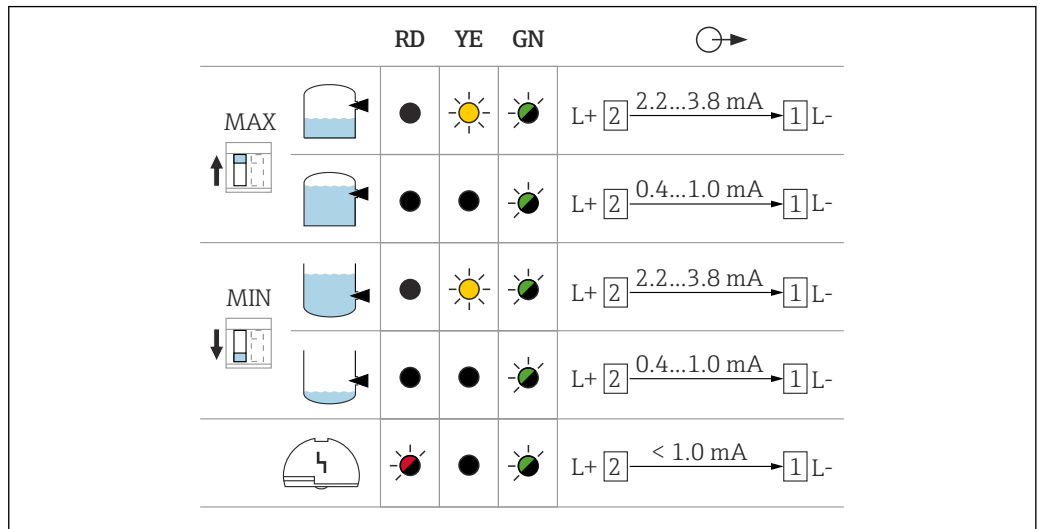

14 Behavior of switch output and signaling, electronic insert FEL68

MAXDIP switch for setting MAX safety mode

MIN DIP switch for setting MIN safety mode

RD Red LED for alarm

YE Yellow LED, switch status

GN Green LED, operational status, device on

Electronic insert FEL68 with Bluetooth module

The Bluetooth module for use in conjunction with the electronic insert FEL68 (2-wire NAMUR) must be ordered separately with the necessary battery.

- The following versions can be optionally selected in the Product Configurator:
Application package: Heartbeat Verification + Monitoring for NAMUR output
Accessory mounted: Bluetooth for NAMUR output

The order number of the **Bluetooth module, including the required battery**, are subsequently displayed in the Product Configurator.

LED module VU120 (optional)

Supply voltage	U = 12 to 55 V _{DC} , U = 19 to 253 V _{AC} , 50 Hz/60 Hz
Power consumption	P ≤ 0.7 W, S < 6 VA
Current consumption	I _{max} = 0.4 A

Signaling of operational status

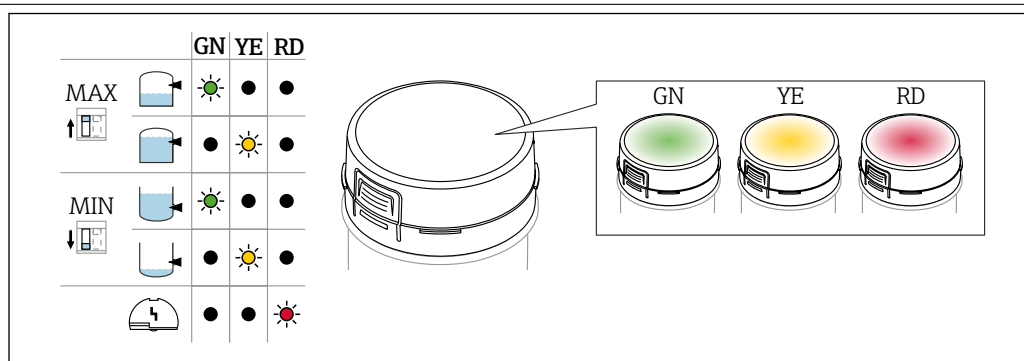

15 LED module, the LED lights up in green (GN), yellow (YE) or red (RD)

A brightly lit LED indicates the operational status (switch status or alarm status). The LED module can be connected to the following electronic inserts: FEL62, FEL64, FEL64DC.

See the accompanying Operating Instructions for more detailed information on connection and the switching states. Documentation currently available on the Endress+Hauser- website: www.endress.com → Downloads.

Bluetooth module and Heartbeat Technology

Bluetooth module VU121 (optional)

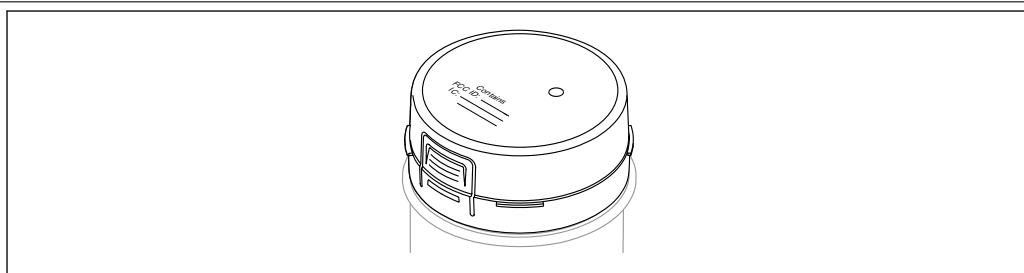

16 Bluetooth module VU121

- The Bluetooth module can be connected via the COM interface to the following electronic inserts: FEL61, FEL62, FEL64, FEL64 DC, FEL67, FEL68 (2-wire NAMUR).
- The Bluetooth module is only available in conjunction with the Heartbeat Verification + Monitoring application package.
- The Bluetooth module with battery is suitable for use in hazardous areas.
- The Bluetooth module must be ordered separately, including the required battery, for use in conjunction with electronic insert FEL68 (2-wire NAMUR).

For additional information about the connection, see the Operating Instructions for the device. Documentation currently available on the Endress+Hauser- website: www.endress.com → Downloads.

Batteries - use and handling

For energy-related reasons, Bluetooth module VU121 requires a special battery when operated with electronics insert FEL68 (2-wire NAMUR).



The battery is categorized as dangerous goods when transported by air and must not be installed in the device when shipped.

Replacement batteries can be purchased from a specialist retailer.

Replacement batteries

Only the following types of AA 3.6 V lithium batteries made by the manufacturers listed below are suitable as replacement batteries:

- SAFT LS14500
- TADIRAN SL-360/s
- XENOENERGY XL-060F

Isolation lug in battery compartment

NOTICE

Removal of grounding lug causes battery to discharge prematurely

Removing the grounding lug from the battery compartment of the Bluetooth module causes the battery to discharge prematurely, regardless of the sensor power supply.

- ▶ As long as the sensors are in storage, the grounding lug must remain in the battery compartment of the Bluetooth module.

Operating life

- If the batteries are empty, Bluetooth connection is no longer possible.
- At ambient temperatures from +10 to +40 °C (+50 to +104 °F), the service life of the Bluetooth module without replacing the battery is at least 5 years with a maximum of 60 downloads of complete datasets.

Requirement: The sensor is 99 % in the "good" state (demand requires increased power consumption)

The battery life is based on a scenario where the sensor is connected and powered.

Replacing the battery

- ▶ Before replacing the battery, the Bluetooth module must be disconnected from electronic insert FEL68.
 - ↳ Only then will the battery status display be detected correctly.

Approvals

The Bluetooth module is approved for use in the following types of protection for devices: Ex i, Ex d, Ex e or Ex t. The temperature class of the device is limited to T4 to T1 if the Bluetooth module is used in type of protection Ex i /IS in conjunction with electronic insert FEL68 (2-wire NAMUR) and the required battery in the Bluetooth module.

Additional technical data

- Free-field range: 50 m (165 ft) max.
- Operation radius with intervisibility around the device: 10 m (33 ft)



For documentation on radio approvals, see the Endress+Hauser website: www.endress.com → Downloads.

Heartbeat Technology

Heartbeat Technology module

The software package consists of 3 modules. These three modules combined check, evaluate and monitor device functionality and process conditions.



- Heartbeat Diagnostics
- Heartbeat Verification
- Heartbeat Monitoring

Performance characteristics

Reference operating conditions

- As per IEC 62828-2
- Ambient temperature: +23 °C (+73 °F)
- Process temperature: +23 °C (+73 °F)
- Humidity φ = constant, in range: 5 to 80 % rF \pm 5 %
- Medium density (water): 1 g/cm³ (62.4 lb/ft³)
- Medium viscosity: 1 mPa·s
- Atmospheric pressure p_U = constant, in range: 860 to 1060 mbar (12.47 to 15.37 psi)
- Process pressure: atmospheric pressure/unpressurized
- Sensor installation: vertically from above
- Switch direction of sensor: uncovered to covered
- Load with HART: 250 Ω
- Supply voltage: 24 V DC \pm 3 V DC

Take switch point into consideration

The following are typical switch points, depending on the orientation of the point level switch.

Water +23 °C (+73 °F)

-  Minimum distance between the tuning fork and the tank wall or pipe wall: 10 mm (0.39 in)

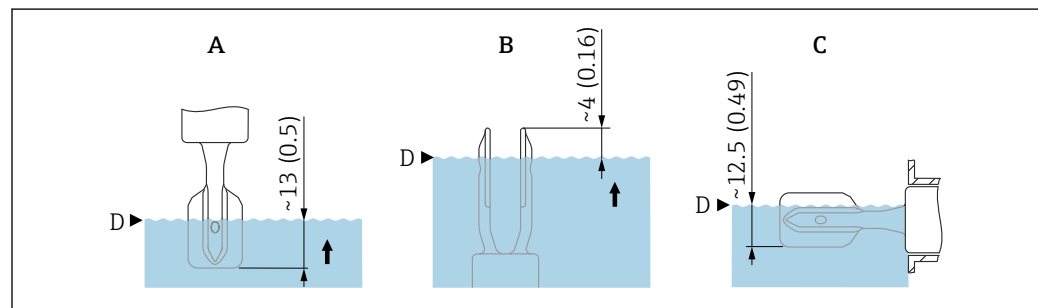

A0037915

 17 Typical switch points. Unit of measurement mm (in)

- A Installation from above
- B Installation from below
- C Installation from the side
- D Switch point

Maximum measured error At reference operating conditions: max. \pm 1 mm (0.04 in) at switch point

Hysteresis Typically 2.5 mm (0.1 in)

Non-repeatability 0.5 mm (0.02 in)

Influence of the process temperature The switch point moves from +1.4 to -2.6 mm (+0.06 to -0.1 in) in the temperature range of -50 to +150 °C (-58 to +302 °F)

Influence of the process pressure The switch point moves from 0 to 2.6 mm (0 to 0.1 in) in the pressure range of -1 to +64 bar (-14.5 to +928 psi)

Influence of the density of the process medium (at room temperature and normal pressure)

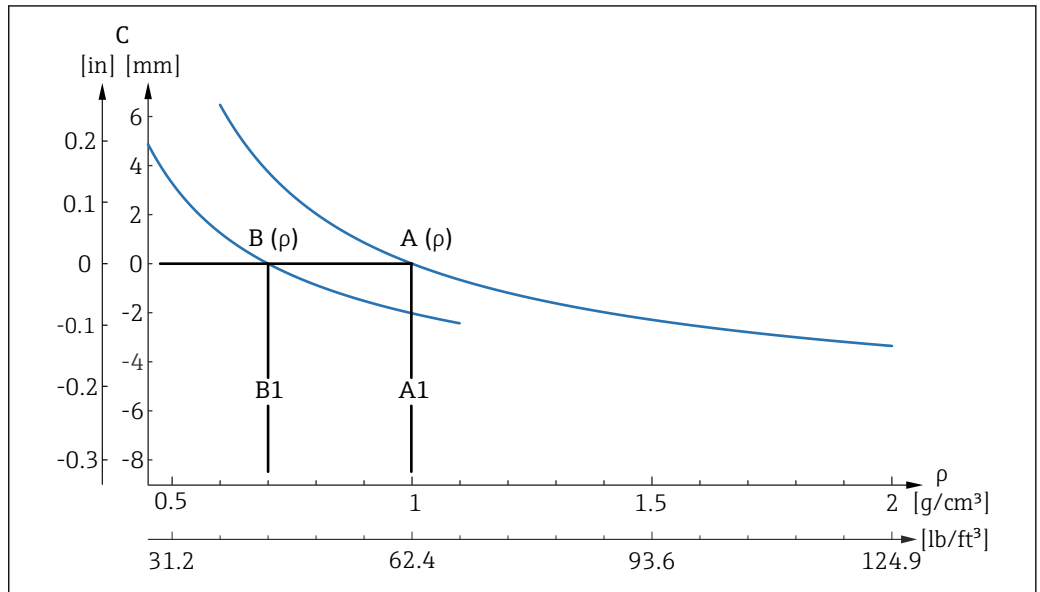

18 Switch point deviation over density, 316L

- A Density switch setting ($\rho > 0.7 \text{ g/cm}^3$ (43.7 lb/ft³))
 A1 Reference operating condition $\rho = 1 \text{ g/cm}^3$ (62.4 lb/ft³)
 B Density switch setting ($\rho > 0.5 \text{ g/cm}^3$ (31.2 lb/ft³))
 B1 Reference operating condition $\rho = 0.7 \text{ g/cm}^3$ (43.7 lb/ft³)
 C Switch point deviation

Density setting

- TC_{typ.}, [mm/10 k]
 - $\rho > 0.7 \text{ g/cm}^3$ (43.7 lb/ft³): -0.2
 - $\rho > 0.5 \text{ g/cm}^3$ (31.2 lb/ft³): -0.2
- Pressure_{typ.}, [mm/10 bar]
 - $\rho > 0.7 \text{ g/cm}^3$ (43.7 lb/ft³): -0.3
 - $\rho > 0.5 \text{ g/cm}^3$ (31.2 lb/ft³): -0.4

Mounting

Mounting location, orientation

Mounting instructions

- Any orientation for compact version or version with a pipe length of up to 500 mm (19.7 in) approx.
- Vertical orientation from above for device with long pipe
- Minimum distance between the tuning fork and the tank wall or pipe wall: 10 mm (0.39 in)

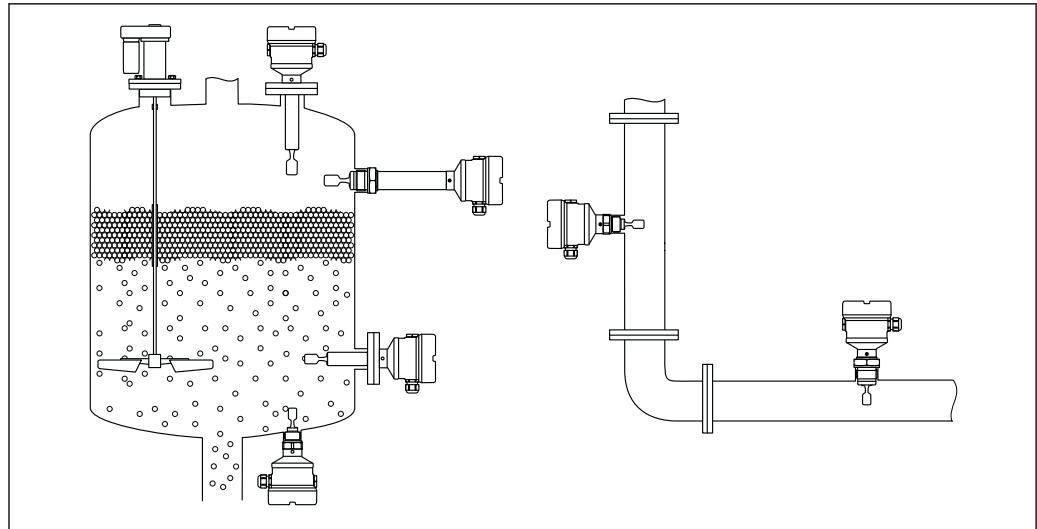

A0037879

19 Installation examples for a vessel, tank or pipe

Installation instructions

Take viscosity into consideration

- i** Viscosity values
- Low viscosity: $< 2\,000$ mPa·s
 - High viscosity: $> 2\,000$ to $10\,000$ mPa·s

Low viscosity

- i** Low viscosity, e.g. water: $< 2\,000$ mPa·s

It is permitted to position the tuning fork within the installation socket.

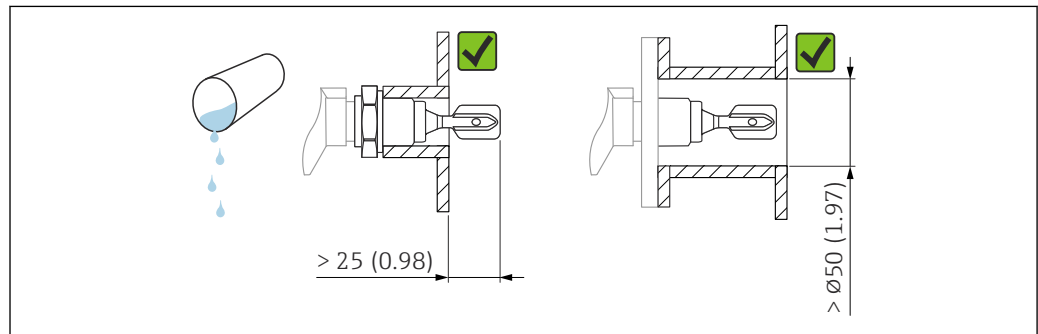

A0033297

20 Installation example for low-viscosity liquids. Unit of measurement mm (in)

High viscosity

NOTICE

Highly viscous liquids may cause switching delays.

- ▶ Make sure that the liquid can run off the tuning fork easily.
- ▶ Deburr the socket surface.

- i** High viscosity, e.g. viscous oils: $\leq 10\,000$ mPa·s

The tuning fork must be located outside the installation socket!

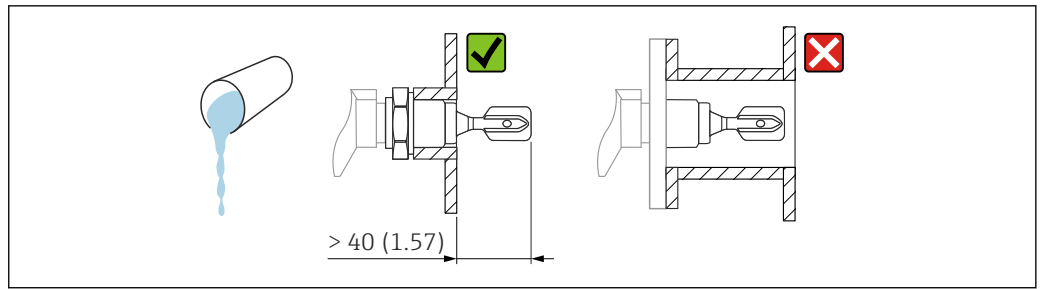

A0037948

21 Installation example for a highly viscous liquid. Unit of measurement mm (in)

Avoid buildup

- Use short installation sockets to ensure that the tuning fork projects freely into the vessel
- Leave sufficient distance between the buildup expected on the tank wall and the tuning fork

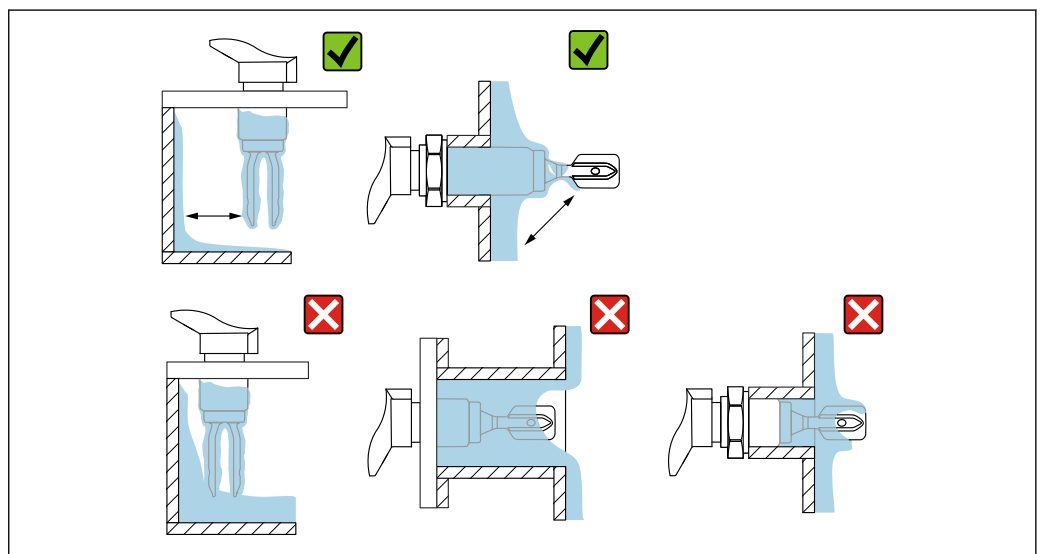

A0033239

22 Installation examples for a highly viscous process medium

Take clearance into consideration

Allow sufficient space outside the tank for mounting, connection and settings involving the electronic insert.

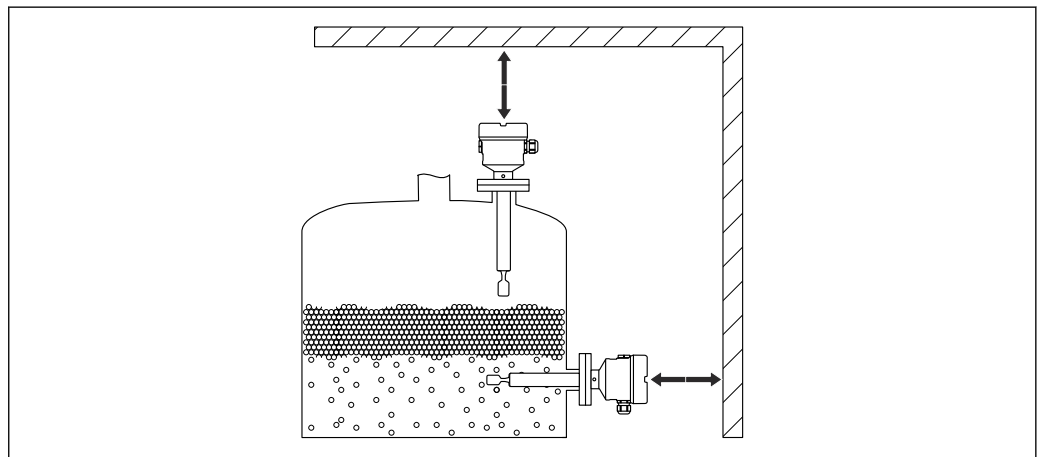

A0033236

23 Take clearance into consideration

Aligning the tuning fork using the marking

The tuning fork can be aligned using the marking in such a way that the medium drains off easily and buildup is avoided.

Markings are labeled on the process connection by means of:
Material specification, thread designation, circle, line or double line

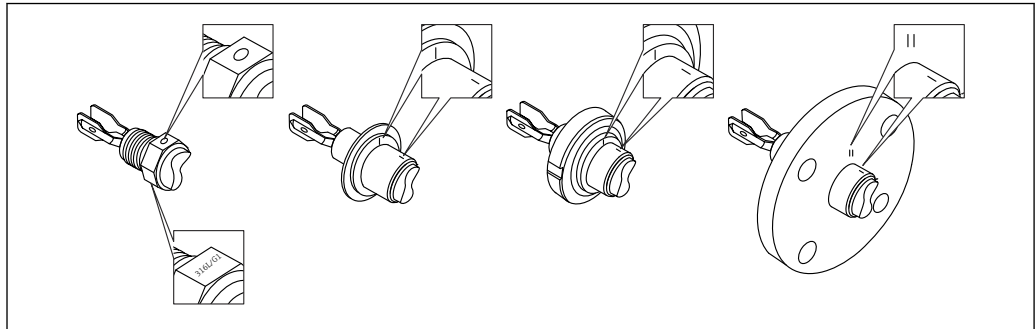

A0039125

24 Position of the tuning fork when installed horizontally in the vessel using the marking

Installing the device in piping

- Flow velocity up to 5 m/s with a viscosity of 1 mPa·s and density of 1 g/cm³ (62.4 lb/ft³) (SGU). Check for correct functioning in the event of other process medium conditions.
- The flow will not be significantly impeded if the tuning fork is correctly aligned and the marking is pointing in the direction of flow.
- The marking is visible when installed.

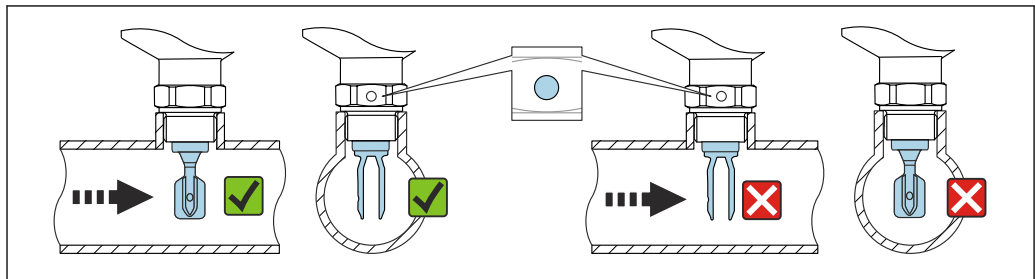

A0034851

25 Installation in pipes (take fork position and marking into consideration)

Aligning the cable entry

All housings can be aligned.

Housing without locking screw

The device housing can be rotated up to 350°.

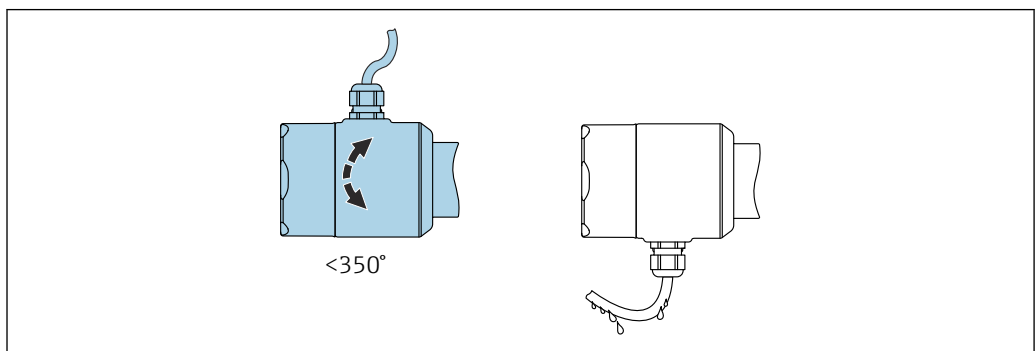

A0052359

26 Housing without locking screw with drip loop

Housing with locking screw

- i** Housings with locking screw:
- The housing can be turned and the cable aligned by turning the locking screw.
 - The locking screw is not tightened when the device is delivered.

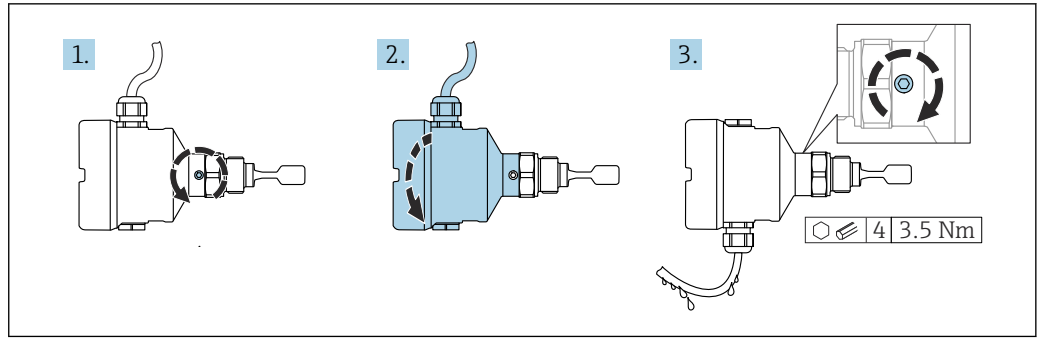

A0037347

27 Housing with external locking screw and drip loop

Special mounting instructions

Vessel with heat insulation

If process temperatures are high, the device should be incorporated in the usual vessel insulation system to prevent the electronics from heating as a result of thermal radiation or convection. The insulation in this case should not be higher than the neck of the device.

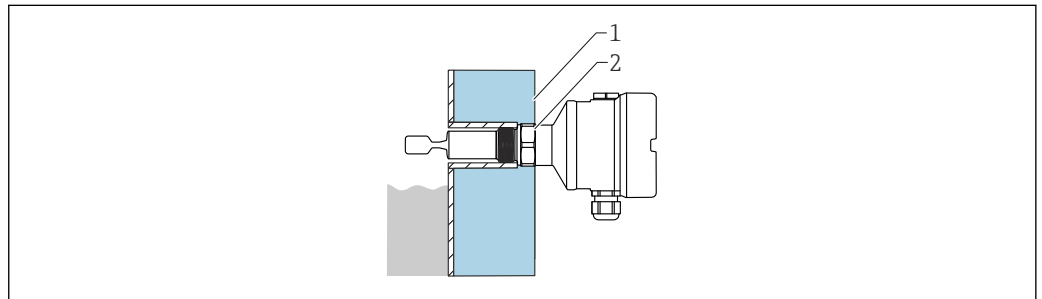

A0051616

28 Vessel with heat insulation (example)

- 1 Vessel insulation
- 2 Insulation up to the housing neck max.

Support the device

Support the device in the event of severe dynamic load. Maximum lateral loading capacity of the pipe extensions and sensors: 75 Nm (55 lbf ft).

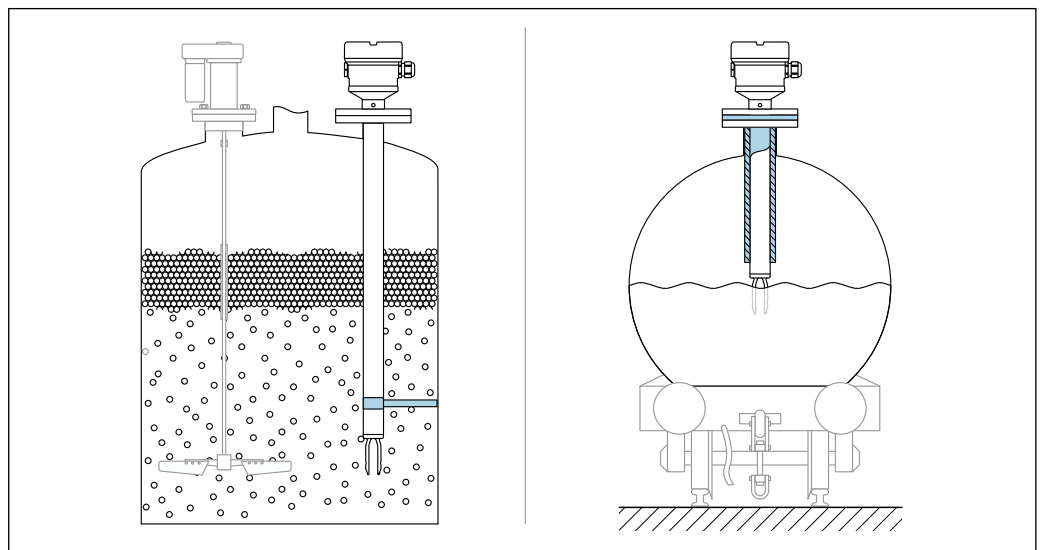

A0031874

29 Examples of support in the event of dynamic load

Weld-in adapter with leakage hole

Weld in the weld-in adapter in such a way that the leakage hole is pointing downwards. This enables any leaks to be detected quickly.

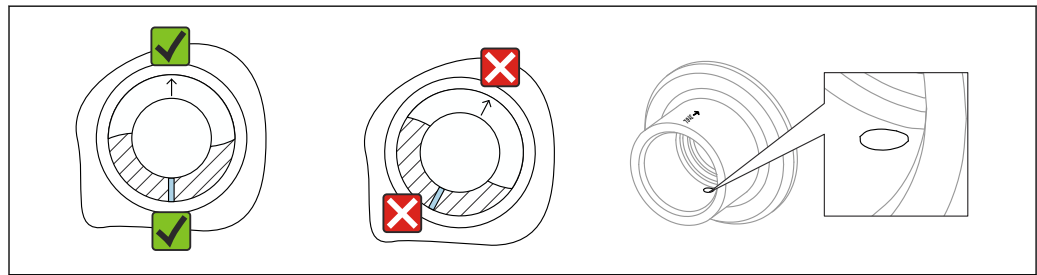

30 Weld-in adapter with leakage hole

Environment

Ambient temperature range

⚠ WARNING

Permitted connection voltage exceeded!

- ▶ For electrical safety reasons, the maximum connection voltage for all electronic inserts at ambient temperatures below -40 °C (-40 °F) is limited to a maximum of 35 V DC.

$-40\text{ to }+70\text{ °C}$ ($-40\text{ to }+158\text{ °F}$)

Optionally available to order:

- -50 °C (-58 °F) with restricted operating life and performance
- -60 °C (-76 °F) with restricted operating life and performance,

i Below -50 °C (-58 °F): devices can be permanently damaged

The minimum permitted ambient temperature of the plastic housing is limited to -20 °C (-4 °F); 'indoor use' applies to North America.

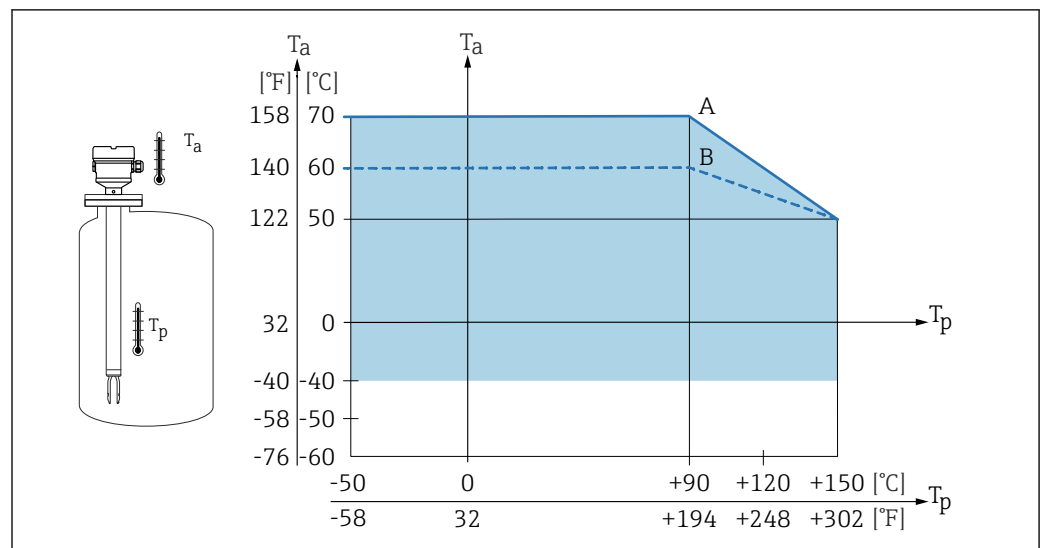

31 Permitted ambient temperature T_a at the housing as a function of the process temperature T_p in the vessel:

- A Device without LED module
- B Device with LED module

For devices with a temperature spacer, the following ambient temperatures apply across the entire process temperature range:

A: 70 °C (158 °F)

B: 60 °C (140 °F)

Maximum current carrying capacity with FEL64

- Without LED module:
 - For FEL64 with hygienic housing
T_p < 90 °C: max. load current 4 A; T_p > 90 °C; max. load current 2 A
 - For FEL64 and all other housings
T_p < 90 °C: max. load current 6 A; T_p > 90 °C; max. load current 4 A
- With LED module:
 - For FEL64 with hygienic housing
T_p < 90 °C: max. load current 4 A; T_p > 90 °C; max. load current 2 A
 - For FEL64 and all other housings
T_p < 90 °C: max. load current 6 A; T_p > 90 °C; max. load current 2 A
-  ■ Low temperatures are not possible for SIL
 - Bluetooth module:
 - -50 °C (-58 °F) for non-Ex, Ex ia and Ex d
 - -60 °C (-76 °F) for non-Ex
 - LED module:
 - -50 °C (-58 °F) for non-Ex, Ex ia and Ex d
 - -60 °C (-76 °F) for non-Ex

Outdoor operation in strong sunlight:

- Mount the device in a shaded location
- Avoid direct sunlight, particularly in warmer climatic regions
- Use a protective cover, can be ordered as an accessory

Hazardous area



In the hazardous area, the permitted ambient temperature can be limited depending on the zones and gas groups. Pay attention to the information in the Ex documentation (XA).

Storage temperature	-40 to +80 °C (-40 to +176 °F) Optional: -50 °C (-58 °F), -60 °C (-76 °F)
Humidity	Operation up to 100 %. Do not open in a condensing atmosphere.
Operating altitude	As per IEC 61010-1 Ed.3: <ul style="list-style-type: none"> ■ Up to 2 000 m (6 600 ft) above sea level ■ Can be extended to 3 000 m (9 800 ft) above sea level if overvoltage protection is used
Climate class	As per IEC 60068-2-38 test Z/AD
Degree of protection	Testing according to IEC 60529 and NEMA 250 IP68 test condition: 1.83 m H ₂ O for 24 h Housing See cable entries Cable entries <ul style="list-style-type: none"> ■ M20 coupling, plastic, IP66/68 NEMA Type 4X/6P ■ M20 coupling, nickel-plated brass, IP66/68 NEMA Type 4X/6P ■ M20 coupling, 316L, IP66/68 NEMA Type 4X/6P ■ M20 coupling, 316L, hygienic, IP66/68/69 NEMA Type 4X/6P ■ M20 thread, IP66/68 NEMA Type 4X/6P ■ G ½ thread, NPT ½, NPT ¾ IP66/68 NEMA Type 4X/6P Degree of protection for M12 plug <ul style="list-style-type: none"> ■ When housing is closed and connecting cable is plugged in: IP66/67 NEMA Type 4X ■ When housing is open or connecting cable is not plugged in: IP20, NEMA Type 1

NOTICE**M12 plug: Loss of IP protection class due to incorrect installation!**

- ▶ The degree of protection only applies if the connecting cable used is plugged in and screwed tight.
- ▶ The degree of protection only applies if the connecting cable used is specified according to IP67 NEMA Type 4X.

 If the "M12 plug" option is selected as the electrical connection, **IP66/67 NEMA Type 4X** applies for all housing types.

Vibration resistance	As per IEC60068-2-64-2008 a(RMS) = 50 m/s ² , f = 5 to 2 000 Hz , t = 3 axes x 2 h
Shock resistance	In accordance with IEC60068-2-27-2008: 300 m/s ² [= 30 g _n] + 18 ms g _n : standard acceleration of gravity
Mechanical load	Support the device in the event of severe dynamic load. Maximum lateral loading capacity of the pipe extensions and sensors: 75 Nm (55 lbf ft).  For more details, see the "Supporting the device" section.
Pollution degree	Pollution degree 2
Electromagnetic compatibility (EMC)	<ul style="list-style-type: none"> ▪ Electromagnetic compatibility as per EN 61326 series and NAMUR recommendation EMC (NE21) ▪ With regard to the safety function (SIL), the requirements of EN 61326-3-x are satisfied  For more details, refer to the EU Declaration of Conformity.

Process

Process temperature range	-50 to +150 °C (-58 to +302 °F) Pay attention to the pressure and temperature dependency.
Thermal shock	≤ 120 K/s
Process pressure range	-1 to +64 bar (-14.5 to 928 psi) for a maximum of 150 °C (302 °F)

⚠ WARNING

The maximum pressure for the device depends on the lowest-rated element, with regard to pressure, of the selected component. This means that it is necessary to pay attention to the process connection as well as the sensor.

- ▶ Pressure specifications,  Technical Information, "Mechanical construction" section.
- ▶ Only operate the device within the specified limits!
- ▶ The Pressure Equipment Directive (2014/68/EU) uses the abbreviation "PS". The abbreviation "PS" corresponds to the MWP (maximum working pressure) of the device.

Process pressure range of the sensors

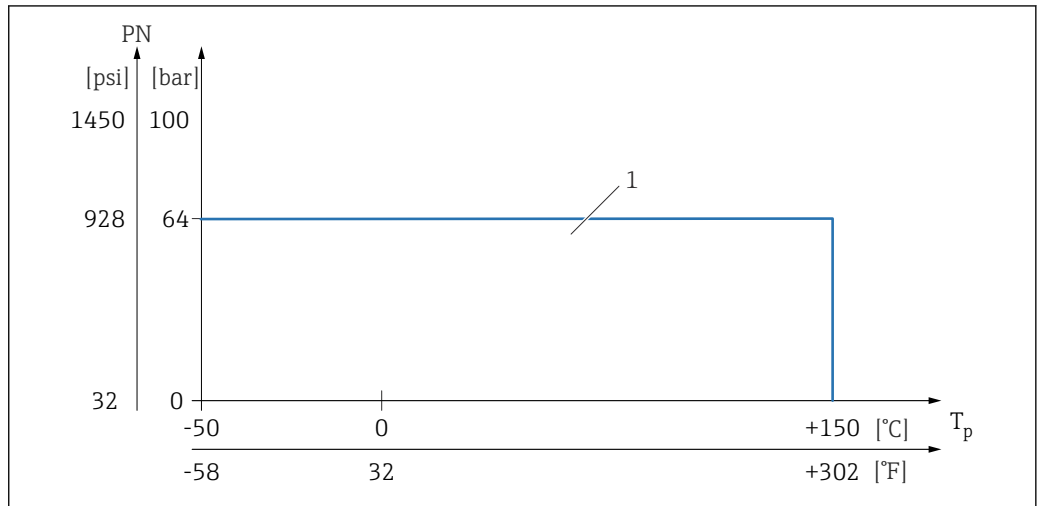

1 PN: 64 bar (928 psi) for a maximum of 150 °C (302 °F), refer to "Process connections" section for exceptions

Overpressure limit

- PN = 64 bar (928 psi): overpressure limit = 1.5 · PN maximum 100 bar (1 450 psi) depending on the selected process connection
- Membrane burst pressure at 200 bar (2 900 psi)

The device function is limited during the pressure test.

Mechanical integrity is guaranteed up to 1.5 times the process nominal pressure PN.

Density

Liquids with density > 0.7 g/cm³ (43.7 lb/ft³)

Switch position > 0.7 g/cm³ (43.7 lb/ft³), order configuration

Liquids with density 0.5 g/cm³ (31.2 lb/ft³)

Switch position > 0.5 g/cm³ (31.2 lb/ft³), can be configured via DIP switch

Liquids with density > 0.4 g/cm³ (25.0 lb/ft³)

- Optionally available to order
 - SIL for defined media and process parameters on request
 - Fixed value that cannot be edited
- The function of the DIP switch is interrupted

 For information on medium differentiation/density detection: Documentation Liquiphant density (FEL60D) with density computer FML621 (Endress+Hauser website www.endress.com → Downloads)

Viscosity

≤ 10 000 mPa·s

Pressure tightness

Up to vacuum

 In vacuum evaporation plants, select the 0.4 g/cm³ (25.0 lb/ft³)/ density setting.

Solids contents

∅ ≤ 5 mm (0.2 in)

Mechanical construction

Design, dimensions

Device height

The device height consists of the following components:

- Housing including cover
- Temperature spacer and/or pressure-tight feedthrough (second line of defense), optional
- Compact version, pipe extension or short pipe version
- Process connection

The individual heights of the components can be found in the following sections:

- Determine the height of the device and add the individual heights
- Take the installation clearance into consideration (space that is needed to install the device)

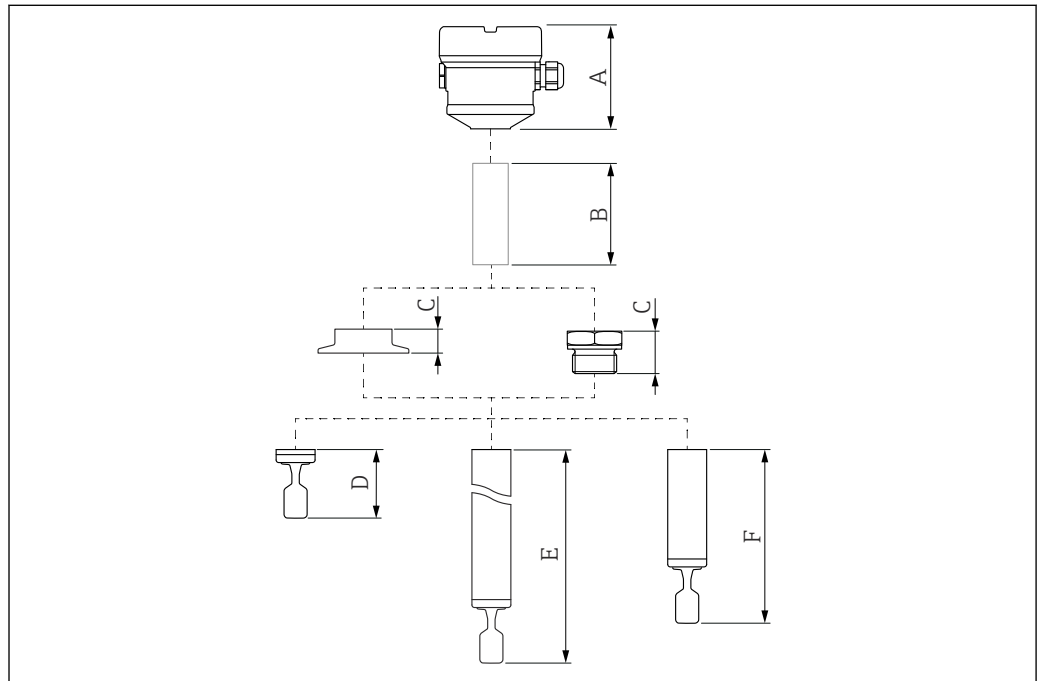

A0052410

32 Components to determine the device height

- A Housing including cover
- B Temperature spacer, pressure-tight feedthrough (optional)
- C Process connection
- D Probe design: compact version with tuning fork
- E Probe design: pipe extension with tuning fork
- F Probe design: short pipe version with tuning fork

Dimensions

Housing and cover

All housings can be aligned. The housing alignment can be fixed on housings with a locking screw.

Devices with a Bluetooth or LED module require a tall cover (transparent plastic cover or cover with sight glass).

Single compartment housing, plastic

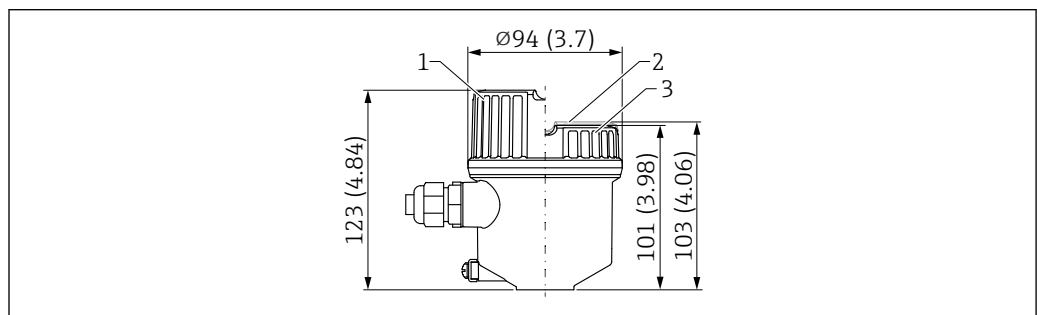

A0035911

33 Dimensions of single compartment housing, plastic. Unit of measurement mm (in)

- 1 Height with plastic cover (transparent)
- 2 Height with cover with plastic sight glass (optional)
- 3 Height with cover without sight glass

Single compartment housing, aluminium, coated

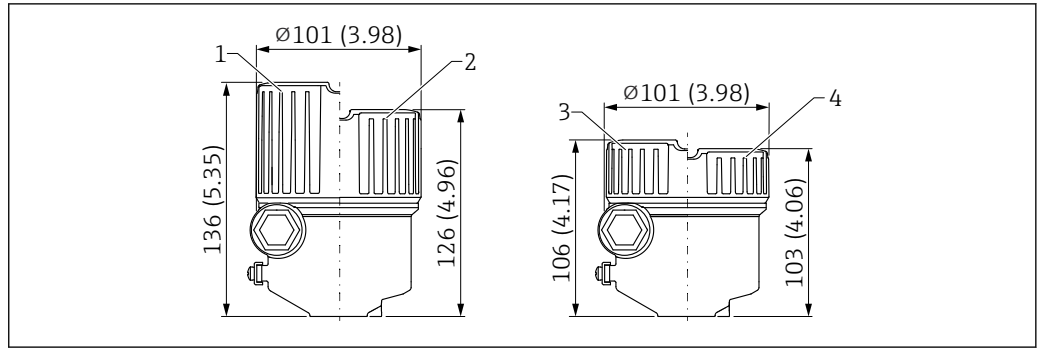

34 Dimensions of single compartment housing, aluminum, coated. Unit of measurement mm (in)

- 1 Height with cover with sight glass made of glass for Ex ec approval
- 2 Height with cover with plastic sight glass
- 3 Height with cover without sight glass
- 4 Height with cover with plastic sight glass (optional)

Single compartment housing, aluminum, coated (Ex d/XP, dust ignition-proof)

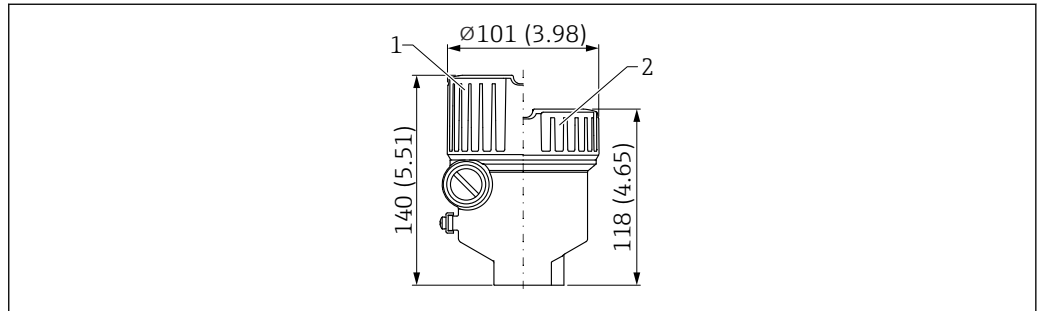

35 Dimensions of single compartment housing, aluminum, coated; with Ex d/XP, dust ignition-proof. Unit of measurement mm (in)

- 1 Height with cover with sight glass made of glass
- 2 Height with cover without sight glass

316L single compartment housing, hygienic

i The housing with ground terminal and cover with cover lock are required for use in hazardous areas with a certain type of protection.

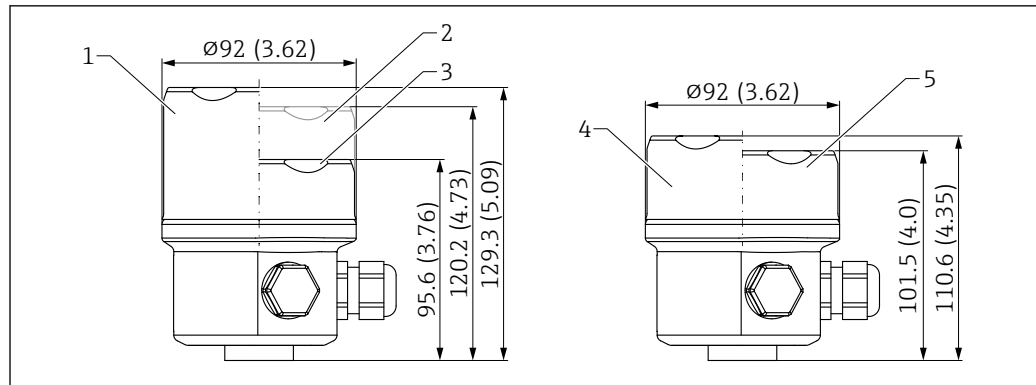

36 Dimensions of single compartment housing, 316L, hygienic. Unit of measurement mm (in)

- 1 Height with cover with sight glass made of glass
- 2 Height with cover with plastic sight glass
- 3 Height with cover without sight glass
- 4 Height with cover with sight glass made of glass (optional)
- 5 Height with cover with plastic sight glass (optional)

Dual compartment housing, L-shaped, aluminum, coated

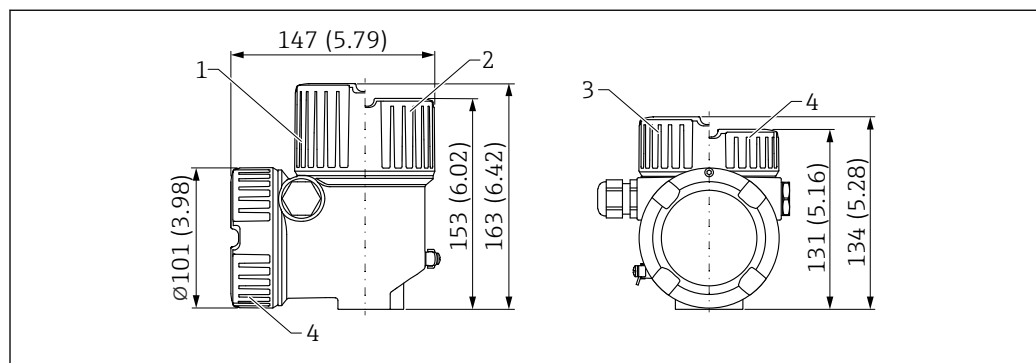

37 Dimensions of dual compartment housing, L-shaped, aluminum, coated; also with Ex d/XP, dust ignition-proof. Unit of measurement mm (in)

- 1 Height with cover with sight glass made of glass
- 2 Height with cover with plastic sight glass
- 3 Height with cover with plastic sight glass (optional)
- 4 Height with cover without sight glass

Ground terminal

- Ground terminal inside the housing, max. conductor cross-section 2.5 mm² (14 AWG)
- Ground terminal outside on the housing, max. conductor cross-section 4 mm² (12 AWG)

Cable glands

Cable outer diameter:

- Plastic: Ø5 to 10 mm (0.2 to 0.38 in)
- Nickel-plated brass: Ø7 to 10.5 mm (0.28 to 0.41 in)
- Stainless steel: Ø7 to 12 mm (0.28 to 0.47 in)
- Stainless steel, hygienic: Ø9 to 12 mm (0.35 to 0.47 in)

i The scope of delivery comprises:

- 1 cable gland installed
- 1 cable gland sealed with dummy plug

A second cable gland (not mounted) is also included in the scope of delivery of the relay electronics.

Exceptions: For Ex d/XP, only threaded insertions are permitted.

Temperature spacer, pressure-tight feedthrough (optional)

The temperature spacer provides sealed insulation for the vessel.

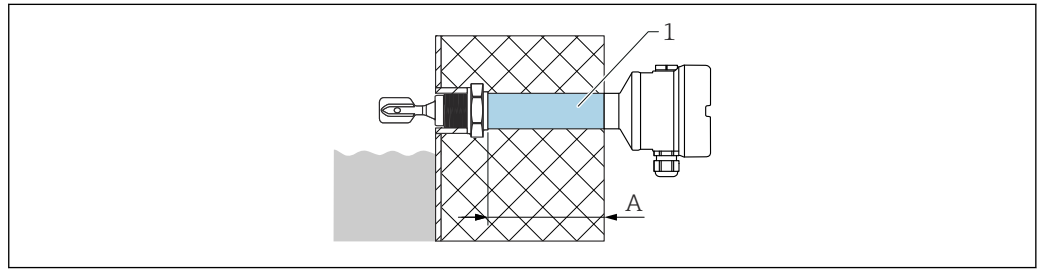

A0036845

- 1 Temperature spacer and/or pressure-tight feedthrough with maximum insulation length
- A 140 mm (5.51 in)

Product Configurator, feature "Sensor design":

- Temperature spacer
- Pressure-tight feedthrough (second line of defense)
If the sensor is damaged, this protects the housing from vessel pressures up to 100 bar (1 450 psi).

i The "Pressure-tight feedthrough" version can only be selected in conjunction with the "Temperature spacer" option.

Probe design

Compact version

Sensor length L: depends on process connection

A For more details, see the "Process connections" section.

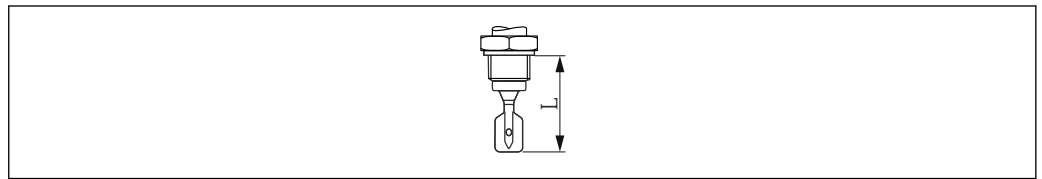

A0042435

38 Probe design: Compact version, sensor length L

Short pipe version

Sensor length L: depends on process connection

- Thread G 1 approx. 118 mm (4.65 in)
- Ingold, flush-mounted tank connection, DIN11851 DIN11864-1SMS1145 pipe union, DRD, Varivent, clamp/Tri-Clamp approx. 115 mm (4.53 in)
- Flush-mounted 1" (G 1 welding boss from Endress+Hauser): approx. 104 mm (4.09 in)

Pipe extension

- Sensor lengths L: 148 to 3 000 mm or 5.83 to 118.11 in
- Length tolerances L: < 1 m (3.3 ft) = -5 mm (-0.2 in), 1 to 3 m (3.3 to 9.8 ft) = -10 mm (-0.39 in)

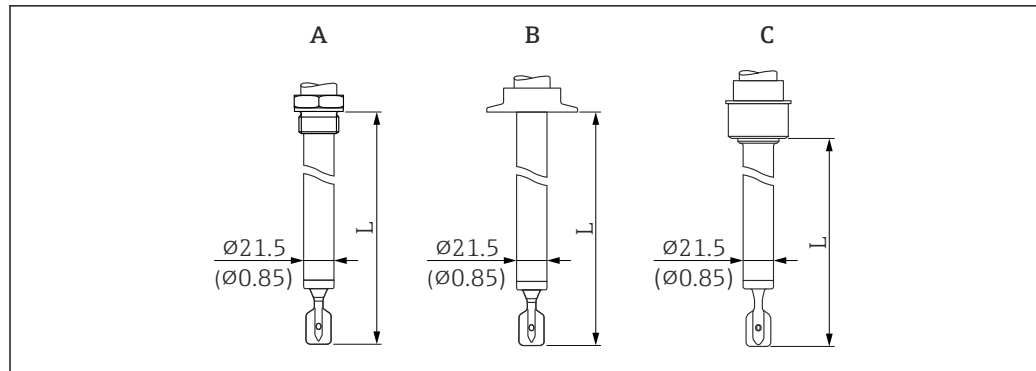

A0051989

■ 39 Probe designs: pipe extension, short pipe version (sensor length L). Unit of measurement mm (in)

A Thread G 1

B E.g. clamp/Tri-Clamp, Varivent

C Flush-mounted tank connection for installation in weld-in adapter

Tuning fork

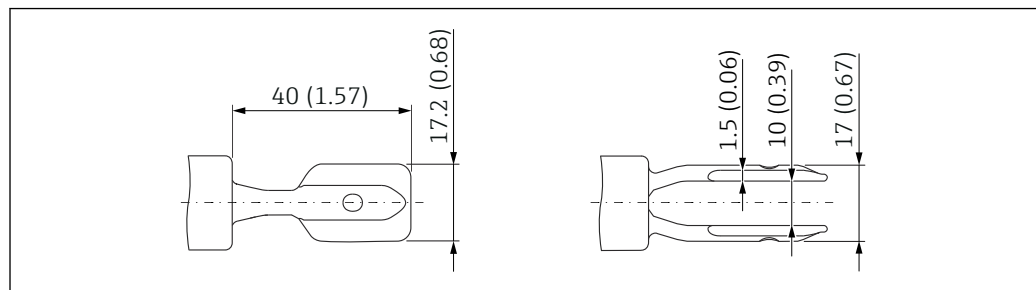

A0038269

■ 40 Tuning fork. Unit of measurement mm (in)

Process connections

Process connection, sealing surface

- Thread ISO228, G
- Ingold
- Flush-mounted tank connection
- DIN11851 pipe union
- DIN11864-1 pipe union
- DRD
- SMS1145 pipe union
- Varivent (Varinline)
- Clamp/Tri-Clamp

Height of process connection

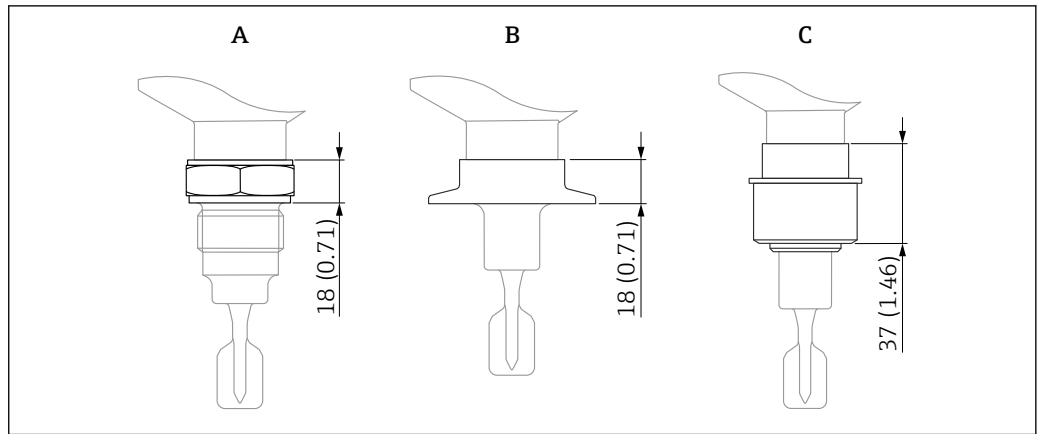

41 Maximum height specification for the process connections. Unit of measurement mm (in)

- A Process connection with threaded connection
- B For example: Clamp/Tri-Clamp, Varivent
- C Flush-mounted tank connection for installation in welding neck

Thread ISO228 G 3/4 for installation in weld-in adapter

G 3/4 with defined thread start for flush mounting in weld-in adapter

- Only for sensor design: compact version
- Material: 316L
- Pressure rating, temperature: ≤ 40 bar (580 psi), ≤ +100 °C (+212 °F)
- Pressure rating, temperature: ≤ 25 bar (363 psi), ≤ +150 °C (+302 °F)
- Weight: 0.2 kg (0.44 lb)
- Accessories: welding neck, optionally available as "Accessory enclosed"

i A seal is not included in the delivery. The maximum temperature and maximum pressure depend on the clamping ring and sealing element used (according to the process connection design). The lowest value applies in each case.

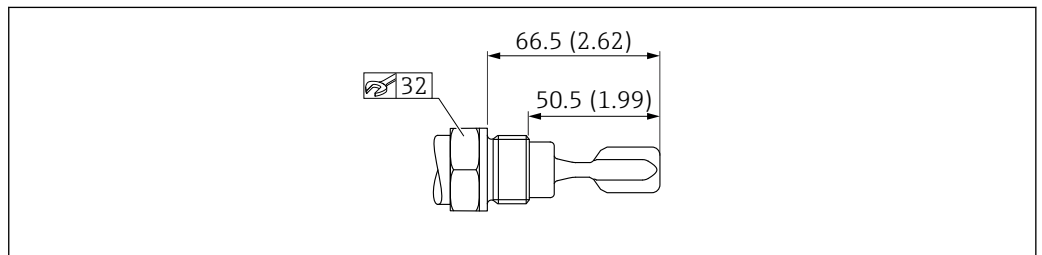

42 Thread ISO228 G 3/4. Unit of measurement mm (in)

Thread ISO228 G 1 for installation in weld-in adapter

G 1 with defined thread start, comprising sealing surface for flush mounting in weld-in adapter

- Material: 316L
- Pressure rating, temperature: ≤ 40 bar (580 psi), ≤ +100 °C (+212 °F)
- Pressure rating, temperature: ≤ 25 bar (363 psi), ≤ +150 °C (+302 °F)
- Weight: 0.33 kg (0.73 lb)
- Accessories: welding neck, optionally available as "Accessory enclosed"

i A seal is not included in the delivery. The maximum temperature and maximum pressure depend on the clamping ring and sealing element used (according to the process connection design). The lowest value applies in each case.

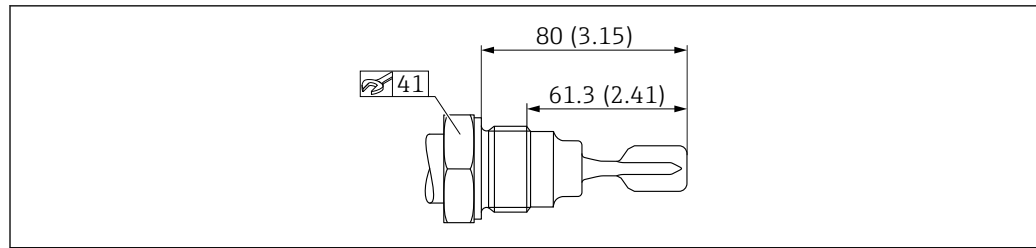

A003551

43 Thread ISO228 G 1. Unit of measurement mm (in)

Ingold fitting

Ingold fitting 25 x 46 mm (2.52 in)

- Material: 316L
- Pressure rating: ≤ 16 bar (232 psi)
- Temperature: ≤ 150 °C (302 °F)
- Weight: 0.2 kg (0.44 lb)
- Scope of delivery: cap-nut G 1¼, seal

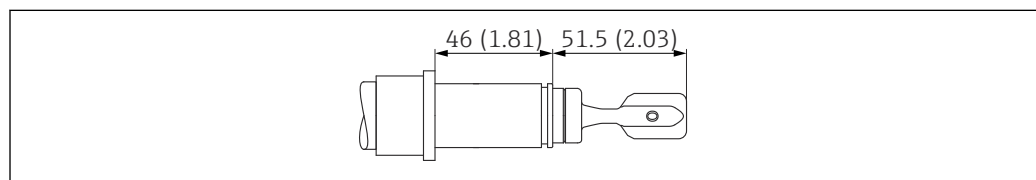

A0051991

44 Ingold fitting 25 x 46 mm (2.52 in). Unit of measurement mm (in)

Flush-mounted tank connection for installation in welding neck

- Material: 316L
- Pressure rating: ≤ 40 bar (580 psi) / ≤ 25 bar (363 psi)
- Temperature: ≤ 100 °C (212 °F) / ≤ 140 °C (284 °F)
- Weight: 0.44 kg (0.97 lb)
- Accessories: welding neck, optionally available as "Accessory enclosed"
- Scope of delivery: cap-nut, seal

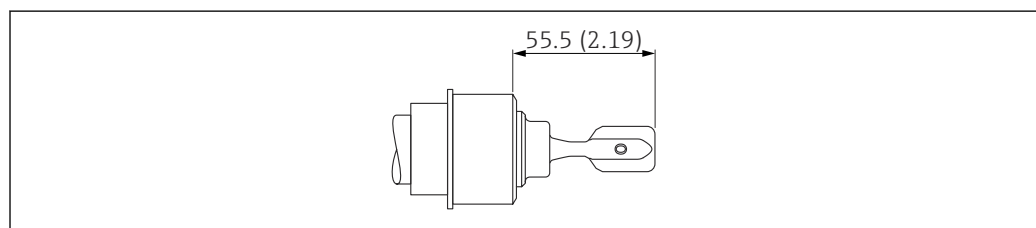

A0051993

45 Flush-mounted tank connection. Unit of measurement mm (in)

DIN11851 pipe union

DN32 PN25

- Material: 316L
- Slotted nut
- Pressure rating: ≤ 40 bar (580 psi) / ≤ 25 bar (363 psi)
- Temperature: ≤ 100 °C (212 °F) / ≤ 140 °C (284 °F)
- Weight: 0.3 kg (0.66 lb)

DN40 PN25

- Material: 316L
- Slotted nut
- Pressure rating: ≤ 40 bar (580 psi) / ≤ 25 bar (363 psi)
- Temperature: ≤ 100 °C (212 °F) / ≤ 140 °C (284 °F)
- Weight: 0.35 kg (0.77 lb)

DN50 PN25

- Material: 316L
- Slotted nut
- Pressure rating: ≤ 25 bar (363 psi)
- Temperature: ≤ 140 °C (284 °F)
- Weight: 0.47 kg (1.04 lb)

i A seal is not included in the delivery. The maximum temperature and maximum pressure depend on the clamping ring and sealing element used (according to the process connection design). The lowest value applies in each case.

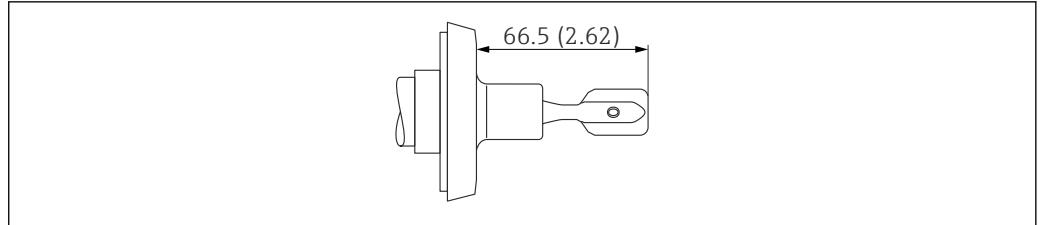

46 DIN11851 pipe union. Unit of measurement mm (in)

A0051995

DIN11864-1 pipe union

DIN11864-1 A DN50 pipe DIN11850

- Material: 316L
- Slotted nut
- Pressure rating: ≤ 25 bar (363 psi)
- Temperature: ≤ 140 °C (284 °F)
- Weight: 0.47 kg (1.04 lb)

i A seal is not included in the delivery. The maximum temperature and maximum pressure depend on the clamping ring and sealing element used (according to the process connection design). The lowest value applies in each case.

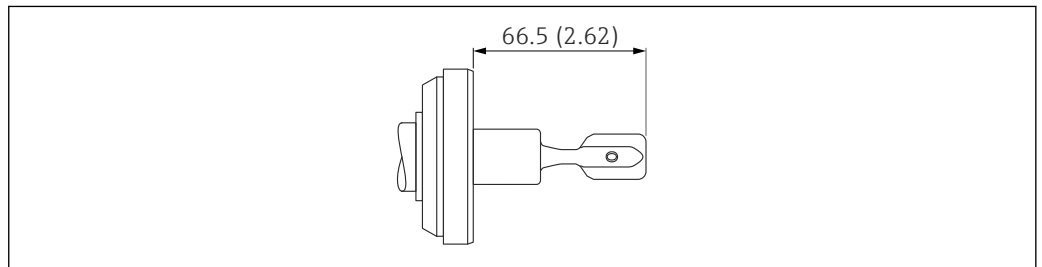

47 DIN11864-1 pipe union. Unit of measurement mm (in)

A0052381

DRD

DRD 65 mm (2.56 in)

- Material: 316L
- Pressure rating: ≤ 40 bar (580 psi) / ≤ 25 bar (363 psi)
- Temperature: ≤ 100 °C (212 °F) / ≤ 140 °C (284 °F)
- Weight: 0.43 kg (0.95 lb)
- Accessories: welding flange with PTFE flat seal, optionally available as "Accessory enclosed"

i A seal is not included in the delivery. The maximum temperature and maximum pressure depend on the clamping ring and sealing element used (according to the process connection design). The lowest value applies in each case.

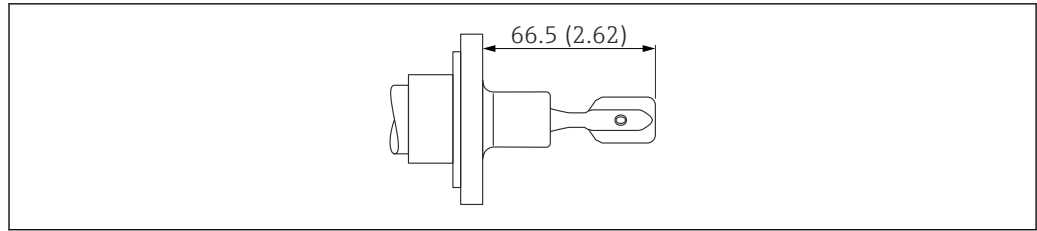

A0051992

48 DRD. Unit of measurement mm (in)

SMS1145 pipe union

SMS 2" PN25

- Material: 316L
- Pressure rating: ≤ 25 bar (363 psi)
- Temperature: ≤ 140 °C (284 °F)
- With cap-nut
- Weight: 0.33 kg (0.72 lb)

i A seal is not included in the delivery. The maximum temperature and maximum pressure depend on the clamping ring and sealing element used (according to the process connection design). The lowest value applies in each case.

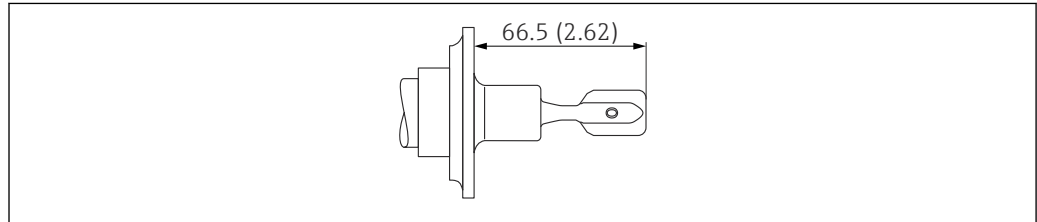

A0051994

49 SMS1145 pipe union. Unit of measurement mm (in)

Varivent (Varinline)

Varivent N pipe DN65-162 PN25

- Material: 316L
- Pressure rating: ≤ 25 bar (363 psi)
- Temperature: ≤ 150 °C (302 °F)
- Suitable for GEA Tuchenhagen
- Weight: 0.72 kg (1.59 lb)

i A seal is not included in the delivery. The maximum temperature and maximum pressure depend on the clamping ring and sealing element used (according to the process connection design). The lowest value applies in each case.

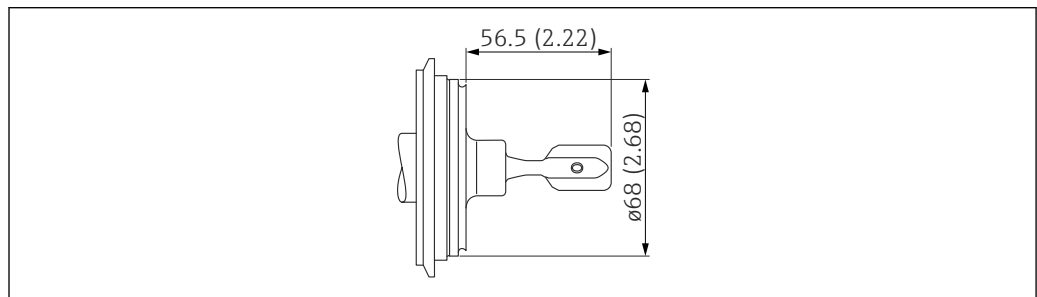

A0051996

50 Varivent N pipe DN65-162 PN25. Unit of measurement mm (in)

Tri-Clamp

NA Connect ISO2852 DN25-38 (1...1 ½"), DIN32676 DN25-40

- Material: 316L
- Pressure rating: ≤ 25 bar (363 psi)
- Temperature: ≤ 150 °C (302 °F)
- Weight: 0.3 kg (0.66 lb)

NA Connect ISO2852 DN40-51 (2"), DIN32676 DN50

- Material: 316L
- Pressure rating: ≤ 25 bar (363 psi)
- Temperature: ≤ 150 °C (302 °F)
- Weight: 0.3 kg (0.66 lb)

 A seal is not included in the delivery. The maximum temperature and maximum pressure depend on the clamping ring and sealing element used (according to the process connection design). The lowest value applies in each case.

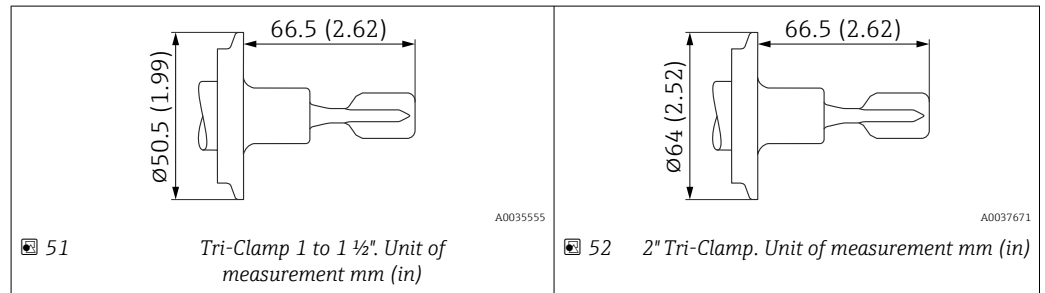
**Weight****Basic weight: 0.65 kg (1.43 lb)**

The basic weight comprises:

- Probe design: compact version
- Electronic insert
- Housing: single compartment, plastic with cover
- Thread, G ¾

 Differences in weight result from the housing, LED or Bluetooth module (incl. tall cover).

Bluetooth module

0.1 kg (0.22 lb)

LED module

0.1 kg (0.22 lb)

Housing

- Single compartment; aluminum, coated: 0.8 kg (1.76 lb)
- Single compartment; 316L, hygienic: 0.45 kg (0.99 lb)
- Dual compartment, L-shaped; aluminum, coated: 1.22 kg (2.69 lb)

Optionally with LED module or Bluetooth module with tall cover in each case: 0.38 kg (0.84 lb)

Temperature spacer

0.6 kg (1.32 lb)

Pressure-tight feedthrough

0.7 kg (1.54 lb)

Pipe extension

- 1000 mm: 0.9 kg (1.98 lb)
- 50 in: 1.15 kg (2.54 lb)

Process connection

See "Process connections" section

Protective cover, plastic

0.2 kg (0.44 lb)

Protective cover, 316L

0.93 kg (2.05 lb)

Materials**Materials in contact with process***Process connection and pipe extension*

316L (1.4404 or 1.4435)

Tuning fork

316L (1.4435)

Seals

Scope of delivery including seal

- Ingold fitting, seal material: EPDM (in compliance with FDA, USP Class VI)
- Flush-mounted tank connection for installation in welding neck, seal material: silicone

Materials not in contact with process*Plastic housing*

- Housing: PBT/PC
- Dummy cover: PBT/PC
- Transparent cover: PA12
- Cover with sight glass: PBT/PC and PC
- Cover seal: EPDM
- Potential equalization: 316L
- Seal under potential equalization: EPDM
- Plug: PBT-GF30-FR
- M20 cable gland: PA
- Seal on plug and cable gland: EPDM
- Threaded adapter as substitute for cable glands: PA66-GF30
- Nameplate: plastic foil
- TAG plate: plastic foil, metal or provided by customer

Aluminum housing, coated

- Housing: aluminum EN AC 43400
- Dummy cover: aluminum EN AC 43400
- Cover with sight glass: aluminum EN AC 43400, PC Lexan 943A synthetic glass
 - Cover with polycarbonate sight glass, optionally available to order
 - In the case of Ex d, the sight glass is made of borosilicate
- Cover seal materials: HNBR
- Cover seal materials: FVMQ (only for low temperature version)
- Plug: aluminum
 - Plastic (PBT-GF30-FR) in Ex-free, Ex i or IS combination with cable gland, plastic, M20 thread or G ½ thread
- Nameplate: plastic foil
- TAG plate: plastic foil, stainless steel or provided by the customer
- M20 cable glands: select material (stainless steel, nickel-plated brass, polyamide)

Stainless steel housing, 316L, hygienic

- Housing: stainless steel AISI 316L (1.4404)
- Dummy cover: stainless steel AISI 316L (1.4404)
- Cover with polycarbonate sight glass optionally available. For dust ignition-proof applications, the sight glass is made of borosilicate.
- Cover seal materials: VMQ
- Plug: stainless steel or plastic
 - Plastic (PBT-GF30-FR) in Ex-free, Ex i or IS combination with cable gland, plastic, M20 thread or G ½ thread
 - Stainless steel for cable glands made of stainless steel or nickel or for Ex t, Ex ia IIIC
- Nameplate: stainless steel housing labeled directly
- TAG plate: plastic foil, stainless steel or provided by the customer
- M20 cable glands: select material (stainless steel, nickel-plated brass, polyamide)

Surface roughness

Surface roughness of the surface in contact with the process:
 Ra < 1.5 µm (59 µin), CoC ASME BPE

Optional:

- Ra < 0.3 µm (12 µin) mechanically polished (3-A, EHEDG)
- Ra < 0.38 µm (15 µin) electropolished, (3-A, EHEDG, CoC ASME BPE)

In this version, the wetted parts are made of 316L (1.4435) in accordance with BN2 (delta-ferrite content < 1 %)

User interface

Operation concept

- Operation with button and DIP switches on the electronic insert
- Display with optional Bluetooth module and SmartBlue app via Bluetooth® wireless technology
- Indication of operational status (switch status or alarm status) with optional LED module (signal lights visible from the outside)

Observe approvals for plastic housing, aluminum housing and stainless steel housing in hygienic applications (combined with DC-PNP (electronic insert FEL62) and relay electronics (electronic inserts FEL64, FEL64DC))

Onsite operation

Elements on the electronic insert

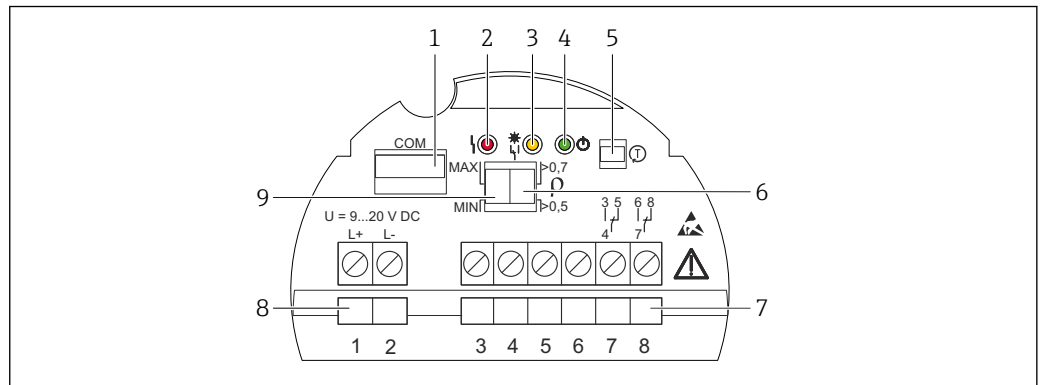

53 Example of electronic insert FEL64DC

- 1 COM interface for additional modules (LED module, Bluetooth module)
- 2 LED, red, for warning or alarm
- 3 LED, yellow, switch status
- 4 LED, green, operational status (device is on)
- 5 Test button, activates functional test
- 6 DIP switch for setting density 0.7 or 0.5
- 7 Terminals (3 to 8), relay contact
- 8 Terminals (1 to 2), power supply
- 9 DIP switch for configuring MAX/MIN safety mode

Operation at electronic insert

MAX/MIN fail-safe mode

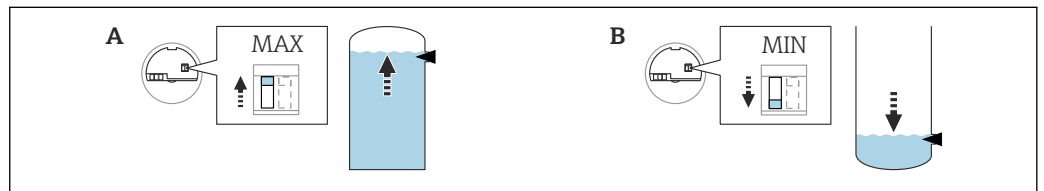

54 Switch position on the electronic insert for fail-safe mode MAX/MIN

- A MAX (maximum fail-safe mode)
- B MIN (minimum fail-safe mode)

- Minimum/maximum quiescent current safety can be switched at the electronic insert
- MAX = Maximum safety: When the tuning fork is covered, the output switches in the direction of demand. Use this for overflow prevention, for example.
- MIN = Minimum safety: When the tuning fork is uncovered, the output switches in the direction of demand. Use this for dry-running protection of pumps, for example.

Density switchover

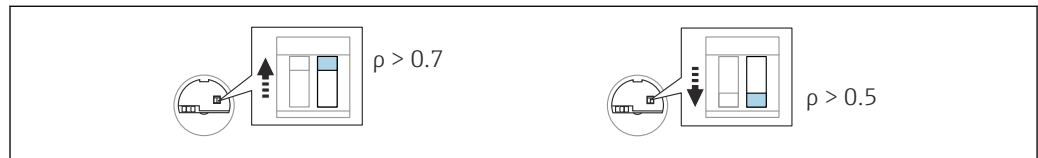

A0033471

55 Switch position on the electronic insert for density

Liquids with density > 0.7 g/cm³ (43.7 lb/ft³)

Switch position > 0.7 g/cm³ (43.7 lb/ft³), order configuration

Liquids with density 0.5 g/cm³ (31.2 lb/ft³)

Switch position > 0.5 g/cm³ (31.2 lb/ft³), can be configured via DIP switch

Liquids with density > 0.4 g/cm³ (25.0 lb/ft³)

- Optionally available to order
 - SIL for defined media and process parameters on request
 - Fixed value that cannot be edited
- The function of the DIP switch is interrupted

i For information on medium differentiation/density detection: Documentation Liquiphant density (FEL60D) with density computer FML621 (Endress+Hauser website www.endress.com → Downloads)

Functional test of the electronic switch with a test magnet

The functional test with the test magnet can be performed without opening the device. To perform the test, hold the test magnet against the marking on the nameplate of the housing. The functional test with the test magnet acts in the same way as the functional test using the test button on the electronic insert.

The functional test can be applied for the following electronic inserts: FEL62, FEL64, FEL64DC, FEL68.

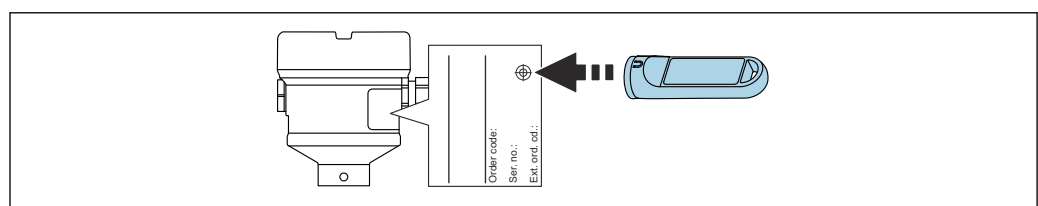

A0033419

56 Functional test with test magnet

i Product Configurator: the test magnet is optionally available.

Local display

LED module VU120 (optional)

A brightly lit LED indicates the operational status (switch status or alarm status). The LED module can be connected to the following electronic inserts: FEL62, FEL64, FEL64DC.

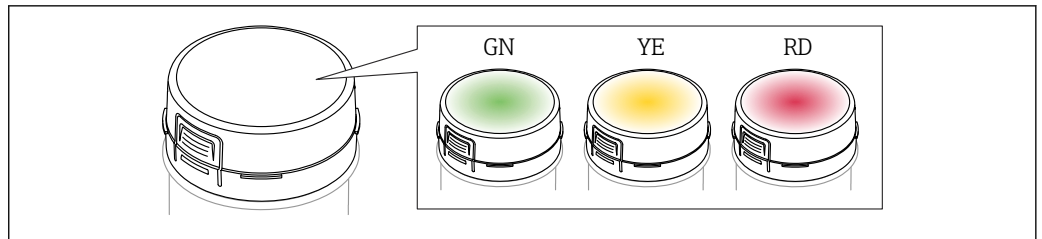

A0043925

57 LED module, the LED lights up in green (GN), yellow (YE) or red (RD)

Additional information → 18 and in the "Accessories" section

Remote operation

Heartbeat diagnostics and verification with Bluetooth® wireless technology

Access via Bluetooth® wireless technology

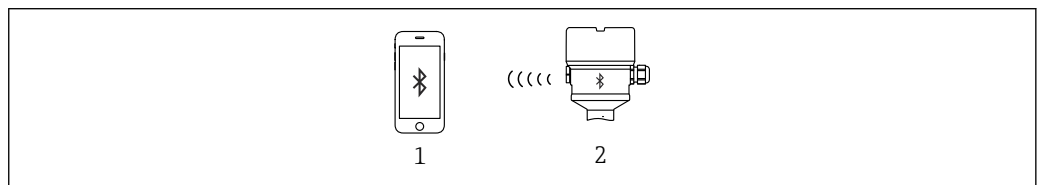

A0033411

58 Remote operation via Bluetooth® wireless technology

- 1 Smartphone or tablet with SmartBlue app
- 2 Device with optional Bluetooth module

Bluetooth module VU121 (optional)

Functions

- Connection via COM interface: Bluetooth module for device diagnostics via a smartphone app or tablet app
- Display the battery status via app when used with electronic insert FEL68 (NAMUR)
- Guidance via the **SIL/WHG Prooftest** wizard
- Visible in the livelist 10 s seconds after the Bluetooth search commences
- Data can be read from the Bluetooth module 60 s after the supply voltage is switched on
- Display of the current oscillation frequency and the switch status of the device

The yellow LED flashes when the Bluetooth module is connected to another Bluetooth device, e.g. mobile phone.

Heartbeat Technology

Additional information in the "Application packages" section.

Diagnostic information

Heartbeat Technology

The electronics module and the tuning fork are checked using Heartbeat Technology, and a verification of the Liquiphant is performed. The switch output is not changed during this test. The test can be performed at any time and does not influence the switch output in the safety circuit. In the case of proof-testing, the SmartBlue app supports users in every step of the test. The switch output is also switched during this test. During the proof-test, alternative monitoring measures must be taken to ensure process safety.

Proof testing

During the proof test, the SmartBlue app provides support for each individual stage of the test (proof-test wizard). The switch output is also switched during this test. During the proof test, alternative monitoring measures must be taken to ensure process safety.

Evaluation of the vibration frequency

If the vibration frequency exceeds the upper warning frequency, a warning is displayed. A warning is activated when the fork becomes corroded, for example. The switch output remains in the current state. The warning is displayed in the SmartBlue app and output in the Heartbeat Technology protocol. When a warning occurs, it is necessary to check the Liquiphant sensor.

The current oscillation frequency must be in the range between the upper and lower alarm frequency. If the current oscillation frequency is above the upper alarm frequency or below the lower alarm frequency, an alarm is output. The output switches to the safety-oriented state.

Certificates and approvals

Current certificates and approvals for the product are available at www.endress.com on the relevant product page:

1. Select the product using the filters and search field.
2. Open the product page.
3. Select **Downloads**.

CE mark	The measuring system meets the legal requirements of the applicable EU Directives. These are listed in the corresponding EU Declaration of Conformity together with the standards applied. Endress+Hauser confirms successful testing of the device by affixing to it the CE mark.
----------------	--

RCM marking	The supplied product or measuring system meets the ACMA (Australian Communications and Media Authority) requirements for network integrity, interoperability, performance characteristics as well as health and safety regulations. Here, especially the regulatory arrangements for electromagnetic compatibility are met. The products bear the RCM marking on the nameplate.
--------------------	---



A0029561

Ex approval	All data relating to explosion protection are provided in separate Ex documentation and are available from the Downloads Area. The Ex documentation is supplied as standard with all Ex devices.
--------------------	--



Ex temperature class: T1 to T6





If using type of protection Ex i and electronic insert FEL68 (NAMUR) and the Bluetooth module in addition (battery required): T4 to T1.

Explosion-protected smartphones and tablets

If used in hazardous areas, mobile end devices with an Ex approval must be used.

Material compliance for contact with food	<p>The device has been developed for food contact applications. Versions can be selected that meet the following requirements:</p> <ul style="list-style-type: none"> ■ EU Food Contact Material (EC) 1935/2004 ■ US Food Contact Material FDA CFR 21 ■ CN Food Contact Material GB 4806
--	---

Hygienic design requirements	<ul style="list-style-type: none"> ■ Notes on installation and certification in accordance with 3-A and EHEDG: <ul style="list-style-type: none"> ▣ SD02503F document "Hygienic approvals" ■ Information on 3-A and EHEDG-certified adapters: <ul style="list-style-type: none"> ▣ TI00426F document "Weld-in adapters, process adapters and flanges" ■ 3-A and EHEDG-certified versions of the sensor are suitable for Cleaning-in-Place (CIP) and Sterilization-in-Place (SIP) without removing them from the plant. This means that the sensor does not need to be removed during cleaning. The maximum permitted pressure and temperature values for sensor and adapter must not be exceeded (see notes in this TI). ■ ASME BPE
-------------------------------------	---

Compliance with requirements derived from cGMP	<p>cGMP is suitable for wetted parts:</p> <ul style="list-style-type: none"> ■ The certificate is only available in English ■ Materials of construction ■ ADI-free based upon EMA/410/01 Rev.3 (TSE/BSE compliant) ■ Polishing and surface finish ■ Material/compound compliance table: USP, FDA
General material compliance	<p>Endress+Hauser guarantees compliance with all relevant laws and regulations, including the current guidelines for materials and substances.</p> <p>Examples:</p> <ul style="list-style-type: none"> ■ RoHS ■ China RoHS ■ REACH ■ POP VO (Stockholm Convention) <p>For further information and general declarations of compliance, see the Endress+Hauser website www.endress.com</p>
Overfill protection	<p>Before mounting the device, observe the documentation from the WHG approvals (German Federal Water Act).</p> <p>Approved for overfill protection and leakage detection.</p> <p> Product Configurator: feature "Additional approval"</p>
Functional safety	<p>The Liquiphant has been developed according to the IEC 61508 standard. The device is suitable for overfill protection and dry-running protection up to SIL 2 (SIL 3 with homogeneous redundancy). A detailed description of the safety functions with Liquiphant, settings and functional safety data are provided in the "Functional Safety Manual" on the Endress+Hauser website: www.endress.com → Downloads.</p> <p> Product Configurator: feature "Additional approval"</p> <p>Subsequent confirmation of usability according to IEC 61508 is not possible.</p>
Radio approval	<p> Further information and currently available documentation can be found on the Endress+Hauser website: www.endress.com → Downloads.</p>
CRN approval	<p>Versions with a CRN approval (Canadian Registration Number) are listed in the corresponding registration documents. CRN-approved devices are marked with a registration number.</p> <p>Any restrictions regarding the maximum process pressure values are listed on the CRN certificate.</p> <p> Product Configurator: feature "Additional approval"</p>
Service	<ul style="list-style-type: none"> ■ Cleaned of oil+grease (wetted) ■ PWIS-free (paint-wetting impairment substances) ■ Switching delay setting to be spec. ■ Setting for MIN safety mode ■ Default density setting > 0.4 g/cm³ (25.0 lb/ft³) ■ Default density setting > 0.5 g/cm³ (31.2 lb/ft³)
Test, certificate, declaration	<ul style="list-style-type: none"> ■ Inspection certificate 3.1, EN10204 (material certificate, wetted parts) ■ AD 2000 (wetted parts), declaration, excluding cast parts ■ CoC ASME BPE, declaration ■ ASME B31.3 process piping, declaration ■ Compliance with requirements derived from cGMP, declaration ■ EU Food Contact Material (EC) 1935/2004 ■ US Food Contact Material FDA CFR 21 ■ CN Food Contact Material GB 4806 ■ Surface roughness test ISO4287/Ra, (wetted parts), test report ■ Delta-ferrite test, internal procedure (wetted parts), test report <p> Documentation currently available on the Endress+Hauser website: www.endress.com → Downloads or with the serial number of the device under Online Tools in the Device Viewer.</p>

TSE (BSE) compliance (ADI free - Animal Derived Ingredients)	<p>As the manufacturer, Endress+Hauser states:</p> <ul style="list-style-type: none"> ▪ That the parts of this product in contact with the process are not made from materials derived from animals or ▪ at least comply with the requirements of guidelines outlined in EMA/410/01 rev. 3 (TSE (BSE) compliance).
Pressure Equipment Directive	<p>Pressure equipment with permitted pressure ≤ 200 bar (2 900 psi)</p> <p>Pressure instruments with a process connection that does not have a pressurized housing do not fall within the scope of the Pressure Equipment Directive, irrespective of the maximum allowable pressure.</p> <p><i>Reasons:</i></p> <p>According to Article 2, point 5 of EU Directive 2014/68/EU, pressure accessories are defined as "devices with an operational function and having pressure-bearing housings".</p> <p>If a pressure instrument does not have a pressure-bearing housing (no identifiable pressure chamber of its own), there is no pressure accessory present within the meaning of the Directive.</p>
Process seal as per ANSI/ISA 12.27.01	<p>North American practice for the installation of process seals. In accordance with ANSI/ISA 12.27.01, Endress+Hauser devices are designed as either single seal or dual seal devices with a warning message. This allows the user to waive the use of - and save the cost of installing - an external secondary process seal in the protective conduit as required in ANSI/NFPA 70 (NEC) and CSA 22.1 (CEC). These instruments comply with the North American installation practice and provide a very safe and cost-saving installation for pressurized applications with hazardous fluids. More information is provided in the Safety Instructions (XA) for the relevant device.</p> <p> The following housings are approved as single seal devices:</p> <ul style="list-style-type: none"> ▪ Single compartment, aluminum ▪ Single compartment, stainless steel 316L, hygienic ▪ Single compartment, plastic
EAC conformity	<p>The measuring system meets the legal requirements of the applicable EAC guidelines. These are listed in the corresponding EAC Declaration of Conformity along with the standards applied.</p> <p>The manufacturer confirms successful testing of the device by affixing to it the EAC mark.</p>
ASME B 31.3/31.1	<p>Design and materials in accordance with ASME B31.3/31.1. The welds are through-penetration welded and meet the requirements of the ASME Boiler and Pressure Vessel Code, Section IX and EN ISO 15614-1.</p>

Order information

Detailed ordering information is available from your nearest sales organization www.addresses.endress.com or in the Product Configurator at www.endress.com:

1. Select the product using the filters and search field.
2. Open the product page.
3. Select **Configuration**.

Product Configurator - the tool for individual product configuration

- Up-to-the-minute configuration data
- Depending on the device: Direct input of measuring point-specific information such as measuring range or operating language
- Automatic verification of exclusion criteria
- Automatic creation of the order code and its breakdown in PDF or Excel output format
- Ability to order directly in the Endress+Hauser Online Shop

TAG

Measuring point (tag)

The device can be ordered with a tag name.

Location of tag name

Select in the additional specification:

- Stainless steel tag plate
- Paper adhesive label
- Tag provided by the customer
- RFID tag
- RFID tag + stainless steel tag plate
- RFID tag + paper adhesive label
- RFID tag + tag provided by the customer
- IEC 61406 stainless steel tag
- IEC 61406 stainless steel tag + NFC tag
- IEC 61406 stainless steel tag, stainless steel tag
- IEC 61406 stainless steel tag + NFC, stainless steel tag
- IEC 61406 stainless steel tag, plate supplied
- IEC 61406 stainless steel tag + NFC, plate supplied

Definition of tag name

Specify in the additional specification:

3 lines of maximum 18 characters each

The specified tag name appears on the selected plate and/or on the RFID tag.

Visualization in SmartBlue app

The first 32 characters of the tag name

The tag name can always be changed specifically for the measuring point via Bluetooth.

Test reports, declarations and inspection certificates

All test reports, declarations and inspection certificates are provided electronically in the *Device Viewer*:

Enter the serial number from the nameplate (www.endress.com/deviceviewer)

**Product documentation on paper**

Test reports, declarations and inspection certificates in hard copy can optionally be ordered with feature 570 "Service", Version I7 "Product documentation on paper". The documents are then provided with the device upon delivery.

Application packages



The following versions can be optionally selected in the Product Configurator:

- Heartbeat Verification + Monitoring application package
 - Can only be selected in conjunction with optional Bluetooth module
- Accessories installed: Bluetooth

The Bluetooth module for use in conjunction with the electronic insert FEL68 (2-wire NAMUR) must be ordered separately with the necessary battery.

- Application package: Heartbeat Verification + Monitoring for NAMUR output
 - Can only be selected in conjunction with Bluetooth module for NAMUR output
- Accessory mounted: Bluetooth for NAMUR output

Heartbeat Technology module**Heartbeat Diagnostics**

Continuously monitors and assesses the device condition and process conditions. Generates diagnostic messages when certain events occur and provides troubleshooting measures in accordance with NAMUR NE 107.

Heartbeat Verification

Performs a verification of the current device condition on demand and generates the Heartbeat Technology verification report showing the verification result.

Heartbeat Monitoring

Continuously provides device and/or process data for an external system. Analysis of this data provides a basis for process optimization and predictive maintenance.

Heartbeat Verification

The "Heartbeat Verification" module contains the **Heartbeat Verification** wizard, which verifies the current instrument health and creates the Heartbeat Technology verification report:

- The wizard can be used via the SmartBlue app.
- The wizard guides the user through the entire process for creating the verification report.
- The operating hours counter and minimum/maximum temperature indicator (peakhold) are displayed.
- In the event of an increase in the oscillation frequency of the fork, a corrosion warning will appear.
- The as-delivered state of the oscillation frequency in air is indicated on the verification report. A high oscillation frequency is an indicator of corrosion. A lower oscillation frequency indicates buildup or a sensor covered by the medium. Deviations of the oscillation frequency from the oscillation frequency in the as-delivered state can be caused by the process temperature and process pressure.

Proof testing for SIL/WHG devices



The proof test is only available for devices with SIL or WHG approval.

The "SIL Proof test" module, the "WHG Proof test" module or the "SIL/WHG Proof test" module contains a **SIL/WHG Prooftest** wizard, which must be performed at appropriate intervals in the following applications: SIL (IEC61508/IEC61511), WHG (German Water Resources Act (Gesetz zur Ordnung des Wasserhaushalts)):

- The wizard can be used via the SmartBlue app.
- The wizard guides the user through the entire process for creating the verification report.
- The verification report can be saved as a PDF file.

Accessories

LED module VU120 (optional)

A brightly lit LED indicates the operational status (switch status or alarm status). The LED module can be connected to the following electronic inserts: FEL62, FEL64, FEL64DC.

Order number: 71437382

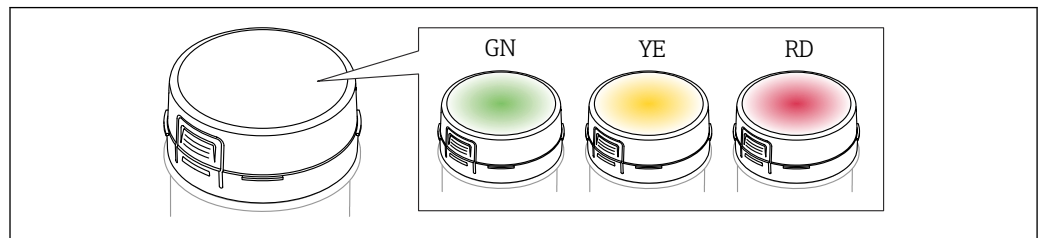

A0043925

59 LED module, the LED lights up in green (GN), yellow (YE) or red (RD)

More detailed information and documentation are available:

- Product Configurator on the Endress+Hauser website www.endress.com
- Endress+Hauser sales organization www.addresses.endress.com



A tall cover, transparent or with sight glass, is required for using and retrofitting the LED module. The cover depends on the housing and approval of the device.

Bluetooth module VU121 (optional)

The Bluetooth module can be connected to the following electronic inserts via the COM interface: FEL61, FEL62, FEL64, FEL64DC, FEL67, FEL68 (2-wire NAMUR).

- Bluetooth module without battery for use in conjunction with electronic inserts FEL61, FEL62, FEL64, FEL64DC and FEL67
Order number: 71437383
- Bluetooth module with battery for use in conjunction with electronic insert FEL68 (2-wire NAMUR)
Order number: 71437381

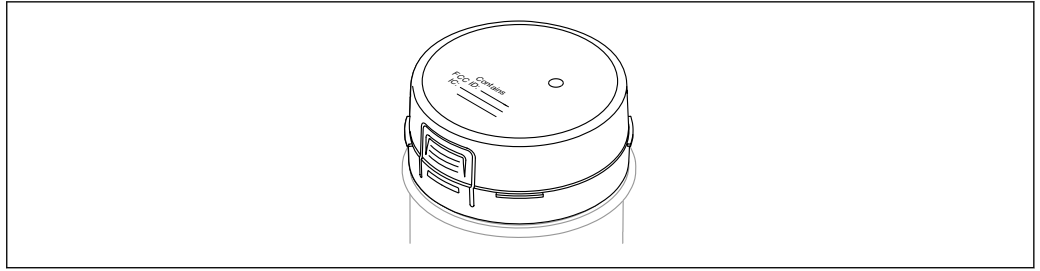

A0039257

60 Bluetooth module VU121

More detailed information and documentation are available:

- Product Configurator on the Endress+Hauser website www.endress.com
- Endress+Hauser sales organization www.addresses.endress.com

A tall cover, transparent or with sight glass, is required for using and retrofitting the Bluetooth module. The cover depends on the housing and approval of the device.

Protective cover for aluminum dual compartment housing

- Material: stainless steel 316L
- Order number: 71438303

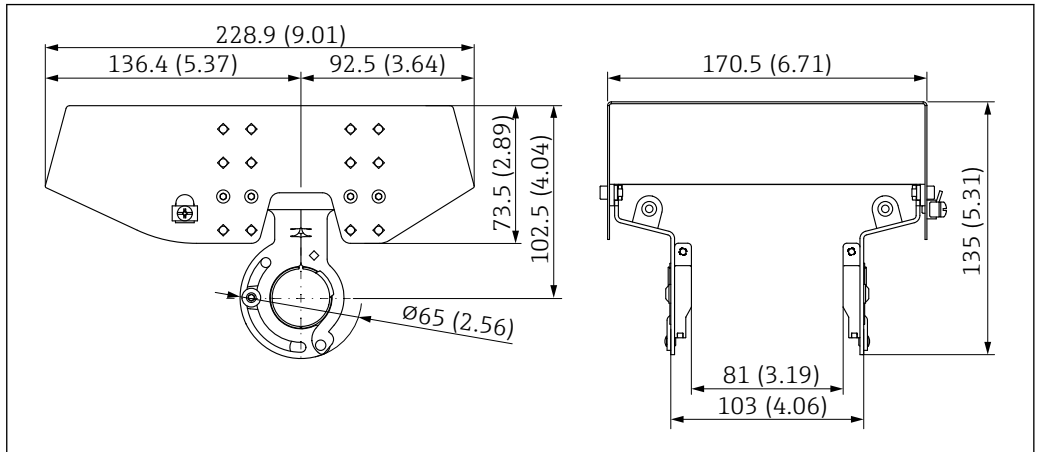

A0039231

61 Protective cover for aluminum dual compartment housing. Unit of measurement mm (in)

Protective cover for aluminum single compartment housing

- Material: plastic
- Order number: 71438291

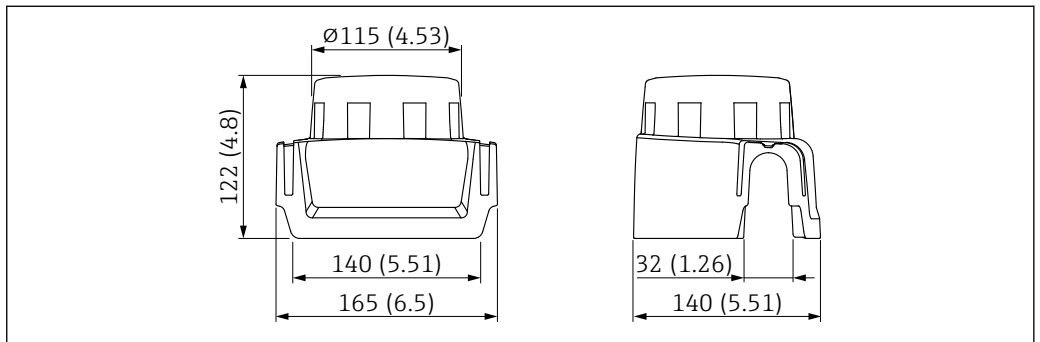

A0038280

62 Protective cover for aluminum single compartment housing. Unit of measurement mm (in)

Weld-in adapter

Various weld-in adapters are available for installation in vessels or pipes. The adapters are optionally available with inspection certificate 3.1 EN10204.

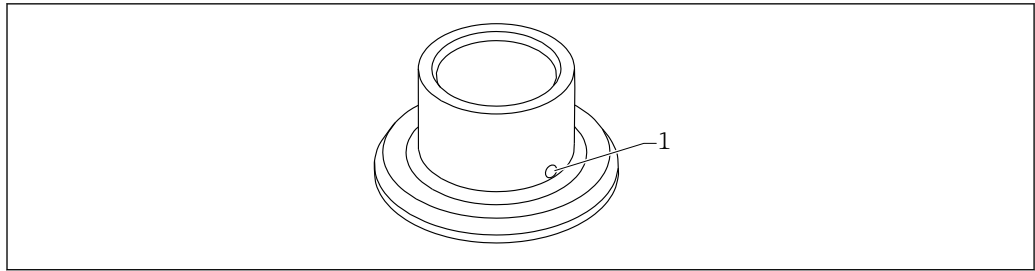

A0023557

63 Weld-in adapter with leakage hole (sample view)

1 Leakage hole

Weld in the weld-in adapter in such a way that the leakage hole is pointing downwards. This enables any leaks to be detected quickly.

- G 1, \varnothing 53 mounting on the pipe
- G 1, \varnothing 60 flush mount on the vessel
- G $\frac{3}{4}$, \varnothing 55 flush mount
- G 1 sensor adjustable
- RD52 sensor adjustable

 For detailed information, see "Technical Information" TI00426F (Weld-in adapters, process adapters and flanges)

Available in the Download Area of the Endress+Hauser website (www.endress.com/downloads).

Test magnet

Order number: 71437508

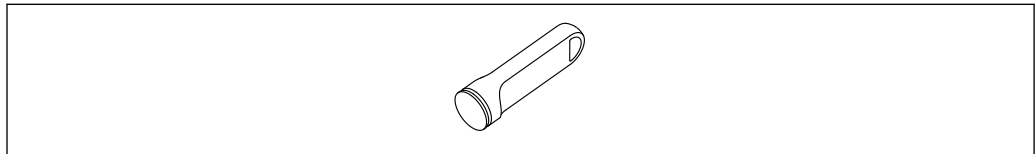

A0039209

64 Test magnet

M12 socket

 The M12 sockets listed are suitable for use in the temperature range -25 to $+70$ °C (-13 to $+158$ °F).

M12 socket IP69

- Terminated at one end
- Angled
- 5 m (16 ft) PVC cable (orange)
- Slotted nut 316L (1.4435)
- Body: PVC
- Order number: 52024216

M12 socket IP67

- Angled
- 5 m (16 ft) PVC cable (gray)
- Slotted nut Cu Sn/Ni
- Body: PUR
- Order number: 52010285

Documentation

-  For an overview of the scope of the associated Technical Documentation, refer to the following:
- *Device Viewer* (www.endress.com/deviceviewer): Enter the serial number from the nameplate
 - *Endress+Hauser Operations app*: Enter serial number from nameplate or scan matrix code on nameplate.

Standard documentation**Document type: Operating Instructions (BA)**

Installation and initial commissioning – contains all functions in the operating menu that are required for a typical measuring task. Functions beyond this scope are not included.

Document type: Description of Device Parameters (GP)

The document is part of the Operating Instructions and serves as a reference for parameters, providing a detailed explanation of each individual parameter of the operating menu.

Document type: Brief Operating Instructions (KA)

Quick guide to the first measured value – includes all essential information from incoming acceptance to electrical connection.

Document type: Safety Instructions, certificates

Depending on the approval, Safety Instructions are supplied with the device, e.g. XA. This documentation is an integral part of the Operating Instructions.

The nameplate indicates which Safety Instructions (XA) apply to the device in question.

Supplementary device-dependent documentation

Additional documents are supplied depending on the device version ordered: Always comply strictly with the instructions in the supplementary documentation. The supplementary documentation is an integral part of the device documentation.

Special Documentation

- SD02662F: Heartbeat Verification + Monitoring application package
- SD02389F: Bluetooth module VU121, radio approval
- SD01622P: Weld-in adapter (installation instructions)
- TI00426F: Weld-in adapters, process adapters and flanges (overview)

Registered trademarks

Bluetooth®

The *Bluetooth*® word mark and logos are registered trademarks owned by the Bluetooth SIG, Inc. and any use of such marks by Endress+Hauser is under license. Other trademarks and trade names are those of their respective owners.

Apple®

Apple, the Apple logo, iPhone, and iPod touch are trademarks of Apple Inc., registered in the U.S. and other countries. App Store is a service mark of Apple Inc.

Android®

Android, Google Play and the Google Play logo are trademarks of Google Inc.



www.addresses.endress.com
