

# Operating Instructions

## Memosens CCS53E

Digital sensor with Memosens technology for determining total chlorine







## Table of contents









<b>1</b>	<b>About this document</b> .....	<b>4</b>	<b>12</b>	<b>Technical data</b> .....	<b>33</b>
1.1	Safety information .....	4	12.1	Input .....	33
1.2	Symbols used .....	4	12.2	Performance characteristics .....	33
<b>2</b>	<b>Basic safety instructions</b> .....	<b>5</b>	12.3	Environment .....	34
2.1	Requirements for the personnel .....	5	12.4	Process .....	34
2.2	Intended use .....	5	12.5	Mechanical construction .....	35
2.3	Workplace safety .....	5			
2.4	Operational safety .....	6			
2.5	Product safety .....	6			
<b>3</b>	<b>Product description</b> .....	<b>7</b>			
3.1	Product design .....	7			
<b>4</b>	<b>Incoming acceptance and product identification</b> .....	<b>10</b>			
4.1	Incoming acceptance .....	10			
4.2	Product identification .....	10			
<b>5</b>	<b>Mounting</b> .....	<b>12</b>			
5.1	Mounting requirements .....	12			
5.2	Mounting the sensor .....	13			
<b>6</b>	<b>Electrical connection</b> .....	<b>18</b>			
6.1	Connecting the sensor .....	18			
6.2	Ensuring the degree of protection .....	18			
6.3	Post-connection check .....	18			
<b>7</b>	<b>Commissioning</b> .....	<b>20</b>			
7.1	Post-installation check and function check ...	20			
7.2	Sensor polarization .....	20			
7.3	Calibrating the sensor .....	20			
7.4	Electrolyte counter .....	21			
<b>8</b>	<b>Diagnostics and troubleshooting</b> ...	<b>22</b>			
<b>9</b>	<b>Maintenance</b> .....	<b>24</b>			
9.1	Maintenance schedule .....	24			
9.2	Maintenance work .....	24			
<b>10</b>	<b>Repair</b> .....	<b>30</b>			
10.1	Spare parts .....	30			
10.2	Return .....	30			
10.3	Disposal .....	30			
<b>11</b>	<b>Accessories</b> .....	<b>31</b>			
11.1	Maintenance kit CCV05 .....	31			
11.2	Device-specific accessories .....	31			

# 1 About this document



## 1.1 Safety information

Structure of information	Meaning
 <b>DANGER</b> <b>Causes (/consequences)</b> If necessary, Consequences of non-compliance (if applicable) ▶ Corrective action	This symbol alerts you to a dangerous situation. Failure to avoid the dangerous situation <b>will</b> result in a fatal or serious injury.
 <b>WARNING</b> <b>Causes (/consequences)</b> If necessary, Consequences of non-compliance (if applicable) ▶ Corrective action	This symbol alerts you to a dangerous situation. Failure to avoid the dangerous situation <b>can</b> result in a fatal or serious injury.
 <b>CAUTION</b> <b>Causes (/consequences)</b> If necessary, Consequences of non-compliance (if applicable) ▶ Corrective action	This symbol alerts you to a dangerous situation. Failure to avoid this situation can result in minor or more serious injuries.
<b>NOTICE</b> <b>Cause/situation</b> If necessary, Consequences of non-compliance (if applicable) ▶ Action/note	This symbol alerts you to situations which may result in damage to property.

## 1.2 Symbols used

	Additional information, tips
	Permitted
	Recommended
	Forbidden or not recommended
	Reference to device documentation
	Reference to page
	Reference to graphic
	Result of a step

### 1.2.1 Symbols on the device

	Reference to device documentation
	Minimum immersion depth
	Do not dispose of products bearing this marking as unsorted municipal waste. Instead, return them to the manufacturer for disposal under the applicable conditions.

## 2 Basic safety instructions

### 2.1 Requirements for the personnel

Installation, commissioning, operation and maintenance of the measuring system may be carried out only by specially trained technical personnel.

- ▶ The technical personnel must be authorized by the plant operator to carry out the specified activities.
- ▶ The electrical connection may be performed only by an electrical technician.
- ▶ The technical personnel must have read and understood these Operating Instructions and must follow the instructions contained therein.
- ▶ Measuring point faults may be repaired only by authorized and specially trained personnel.

 Repairs not described in the Operating Instructions provided must be carried out only directly at the manufacturer's site or by the service organization.

### 2.2 Intended use

Drinking water and industrial water must be disinfected through the addition of appropriate disinfectants such as chlorine gas or inorganic chlorine compounds. The dosing quantity must be adapted to continuously fluctuating operating conditions. If the concentrations in the water are too low, this could jeopardize the effectiveness of the disinfection. On the other hand, concentrations which are too high can lead to signs of corrosion and have an adverse effect on taste, as well as generating unnecessary costs.

The sensor was specifically developed for this application and is designed for continuous measurement of total chlorine in water. In conjunction with measuring and control equipment, it allows optimal control of disinfection.

In this context, the following compounds are referred to collectively as total chlorine:

- Free available chlorine: hypochlorous acid (HOCl), hypochlorite ions (OCl<sup>-</sup>)
- Combined chlorine (chloramines)
- Organically combined chlorine (e.g. cyanuric acid derivatives)

Chloride (Cl<sup>-</sup>) is not recorded.

The sensor is particularly suitable for:

- Monitoring of total chlorine content in wastewater, industrial water, process water, cooling water and pool water
- Measurement, monitoring and control of total chlorine content in fresh water and seawater during the treatment of process water, swimming pool water and whirlpool bathwater

Typical application is the disinfection of wastewater, service water, process and cooling water with chlorine-based disinfectants, particularly at higher pH values up to pH 9.5. In the swimming pool, the CCS53E sensor is used in combination with the CCS51E sensor for free chlorine in order to determine the quantity of combined chlorine (chloramines).

Use of the device for any purpose other than that described, poses a threat to the safety of people and of the entire measuring system and is therefore not permitted.

The manufacturer is not liable for damage caused by improper or non-designated use.

### 2.3 Workplace safety

As the user, you are responsible for complying with the following safety conditions:

- Installation guidelines
- Local standards and regulations
- Regulations for explosion protection

**Electromagnetic compatibility**

- The product has been tested for electromagnetic compatibility in accordance with the applicable international standards for industrial applications.
- The electromagnetic compatibility indicated applies only to a product that has been connected in accordance with these Operating Instructions.

## 2.4 Operational safety

**Before commissioning the entire measuring point:**

1. Verify that all connections are correct.
2. Ensure that electrical cables and hose connections are undamaged.
3. Do not operate damaged products, and protect them against unintentional operation.
4. Label damaged products as defective.

**During operation:**

- ▶ If faults cannot be rectified,  
take products out of service and protect them against unintentional operation.

## 2.5 Product safety

The product is designed to meet state-of-the-art safety requirements, has been tested, and left the factory in a condition in which it is safe to operate. The relevant regulations and international standards have been observed.

### 3 Product description

#### 3.1 Product design

The sensor consists of the following functional units:

- Membrane cap (measuring chamber with membrane)
  - Separates the inner amperometric system from the medium
  - With robust PET membrane and pressure relief valve
  - With support grid between working electrode and membrane for defined and consistent electrolyte film. This ensures a relatively constant indication while reducing the influence of fluctuating pressures and flows
- Sensor shaft with:
  - Large counter electrode
  - Working electrode embedded in plastic
  - Embedded temperature sensor

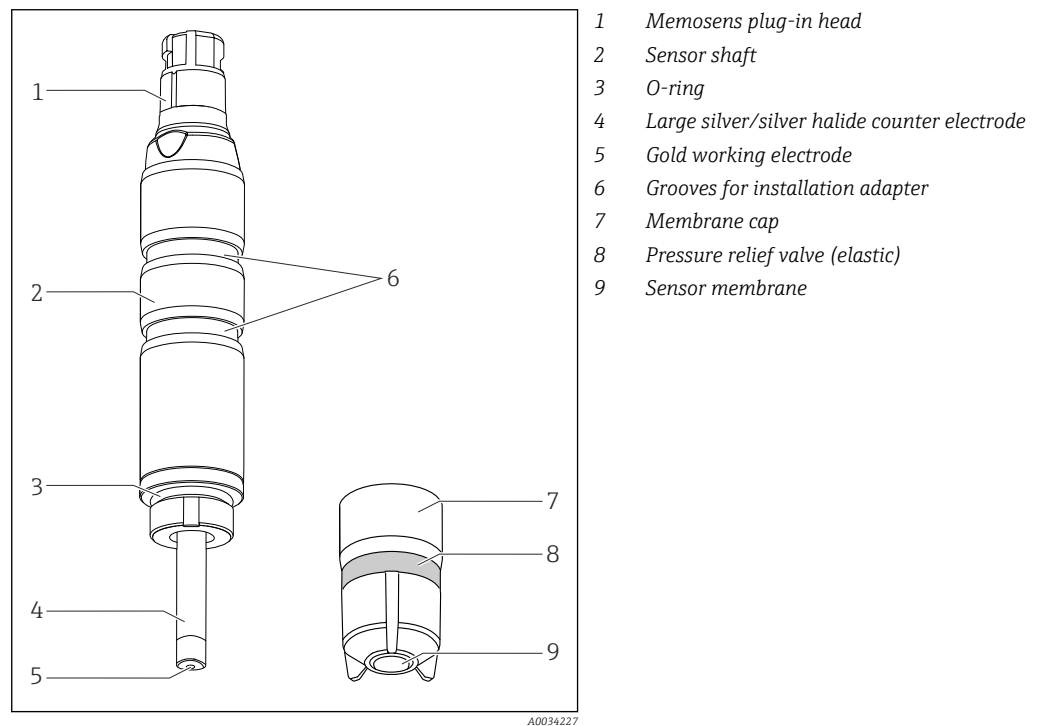

1 Sensor structure

##### 3.1.1 Measuring principle

Total chlorine levels are determined in accordance with the amperometric measuring principle.

In this context, the following compounds are referred to collectively as total chlorine:

- Free available chlorine: hypochlorous acid (HOCl), hypochlorite ions (OCl<sup>-</sup>)
- Combined chlorine (chloramines)
- Organic combined chlorine, e.g. cyanuric acid derivatives

Chloride (Cl<sup>-</sup>) is not recorded.

The sensor is a membrane-covered, two-electrode sensor. A platinum working electrode is used as the working electrode. A counter electrode coated in silver halide is used as the counter and reference electrode.

The membrane cap, which is filled with electrolyte, constitutes the measuring chamber. The measuring electrodes are immersed in the measuring chamber. The measuring

chamber is separated from the medium by means of a microporous membrane. The chlorine compounds contained in the medium diffuse through the sensor membrane.

The constant polarization voltage present between the two electrodes causes the electrochemical reaction of the chlorine compounds at the working electrode. Electron donation at the working electrode and electron acceptance at the counter-electrode cause a current to flow. In the operational range of the sensor, this current flow is proportional to the chlorine concentration under constant conditions and is only slightly pH-dependent in the case of this sensor type. The transmitter uses the current signal to calculate the measured variable for concentration in mg/l (ppm).

### 3.1.2 Effects on the measuring signal

#### pH value

##### *pH dependency*

The sensor is specified for the pH range of pH 5.5 to 9.5. The measuring signal is practically independent within this range. However, if the pH increases from pH 7 to pH 8 the measuring signal for free chlorine is reduced by 10 %.

pH value	Result
< 4	Chlorine is produced if chloride (Cl <sup>-</sup> ) is present in the medium at the same time causing an increase in the measured value.
4 to 9	pH compensation works perfectly in this range. A pH-compensated concentration value can be specified.
> 9	The measuring signal is very weak in this range as the level of hypochlorous acid present is very low. The determined concentration value depends mainly on other conditions of the measuring point.

#### Flow

The minimum flow velocity at the membrane-covered measuring cell is 15 cm/s (0.5 ft/s). When using the Flowfit CYA27 flow assembly, the minimum flow velocity corresponds to a volume flow of 5 l/h (1.3 gal/h) or 30 l/h (7.9 gal/h), depending on the version of the Flowfit CYA27.

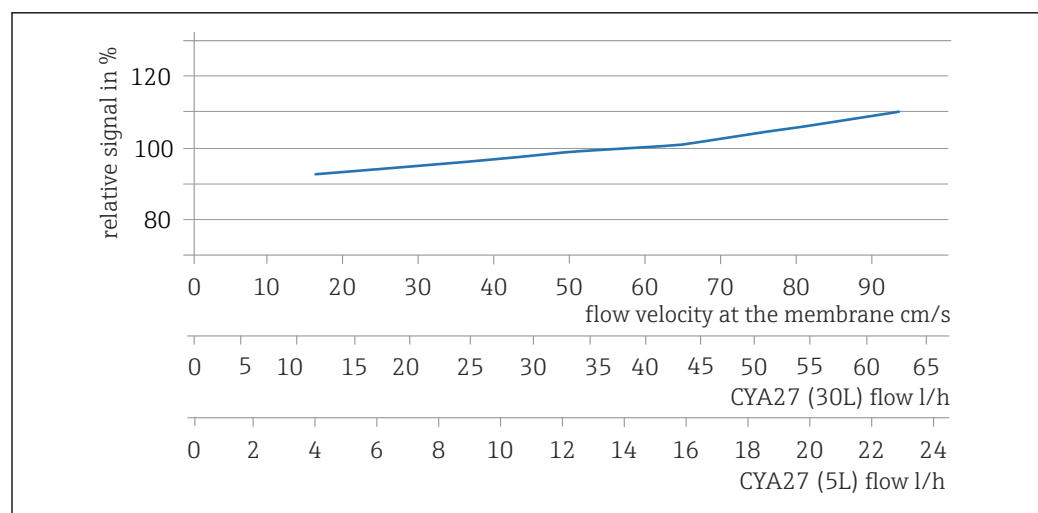

A0054895

The installation of a proximity switch in the assembly enables reliable detection of this invalid operating status, thus triggering an alarm or causing the dosing process to be switched off if necessary.



Below the minimum flow rate, the sensor current is more sensitive to flow fluctuations. For abrasive media, it is recommended not to exceed the minimum flow. If suspended solids are present, which may form deposits, the maximum flow rate is recommended.

### Temperature

Changes in the temperature of the medium affect the measured value:

- Increases in temperature result in a higher measured value (approx. 4.7 % per K)
- Decreases in temperature result in a lower measured value (approx. 4.7 % per K)

Use of the sensor in combination with the Liquiline CM44x, for example, enables automatic temperature compensation (ATC). Recalibration in the case of temperature changes is not necessary.

1. If automatic temperature compensation is disabled at the transmitter, maintain the temperature at a constant level following calibration.
2. Otherwise, recalibrate the sensor.

In the event of normal and slow changes in temperature (0.3 K / minute), the internal temperature sensor is sufficient. In the event of very rapid temperature fluctuations with high amplitude (2 K/minute), an external temperature sensor is necessary to ensure maximum accuracy.



For detailed information on the use of external temperature sensors, see the Operating Instructions for the transmitter

### Cross-sensitivity

- Oxidants, such as bromine, iodine, ozone, chlorine dioxide, permanganate, peracetic acid and hydrogen peroxide result in higher readings than expected.
- Reducing agents, such as sulfides, sulfites, thiosulfates and hydrazine, result in lower readings than expected.

## 4 Incoming acceptance and product identification

### 4.1 Incoming acceptance

1. Verify that the packaging is undamaged.
  - ↳ Notify the supplier of any damage to the packaging.  
Keep the damaged packaging until the issue has been resolved.
2. Verify that the contents are undamaged.
  - ↳ Notify the supplier of any damage to the delivery contents.  
Keep the damaged goods until the issue has been resolved.
3. Check that the delivery is complete and nothing is missing.
  - ↳ Compare the shipping documents with your order.
4. Pack the product for storage and transportation in such a way that it is protected against impact and moisture.
  - ↳ The original packaging offers the best protection.  
Make sure to comply with the permitted ambient conditions.

If you have any questions, please contact your supplier or your local Sales Center.

### 4.2 Product identification

#### 4.2.1 Nameplate

The nameplate provides you with the following information on your device:

- Manufacturer identification
  - Extended order code
  - Serial number
  - Safety information and warnings
  - Certificate information
- ▶ Compare the information on the nameplate with the order.

#### 4.2.2 Product page

[www.endress.com/ccs53e](http://www.endress.com/ccs53e)

#### 4.2.3 Interpreting the order code

The order code and serial number of your product can be found in the following locations:

- On the nameplate
- In the delivery papers

#### Obtaining information on the product

1. Go to [www.endress.com](http://www.endress.com).
2. Page search (magnifying glass symbol): Enter valid serial number.
3. Search (magnifying glass).
  - ↳ The product structure is displayed in a popup window.
4. Click the product overview.
  - ↳ A new window opens. Here you fill information pertaining to your device, including the product documentation.

#### 4.2.4 Manufacturer address

Endress+Hauser Conducta GmbH+Co. KG  
Dieselstraße 24  
70839 Gerlingen  
Germany

#### 4.2.5 Scope of delivery

The scope of delivery comprises:

- Disinfection sensor (membrane-covered, Ø25 mm) with protective cap (ready for use)
- Bottle with electrolyte (50 ml (1.69 fl oz))
- Replacement membrane cap in protective cap
- Operating instructions
- Manufacturer's certificate

#### 4.2.6 Certificates and approvals

Current certificates and approvals for the product are available via the Product Configurator at [www.endress.com](http://www.endress.com).

1. Select the product using the filters and search field.
2. Open the product page.

The **Configuration** button opens the Product Configurator.

## 5 Mounting

### 5.1 Mounting requirements

#### 5.1.1 Orientation

**NOTICE****Do not install upside down!**

There is no secured electrolyte film on the work electrode and therefore no sensor function.

- ▶ Install the sensor in an assembly, support or appropriate process connection at an angle of at least  $15^\circ$  to the horizontal.
- ▶ Other angles of inclination are not permitted.
- ▶ Follow the instructions for installing the sensor in the Operating Instructions of the assembly used.

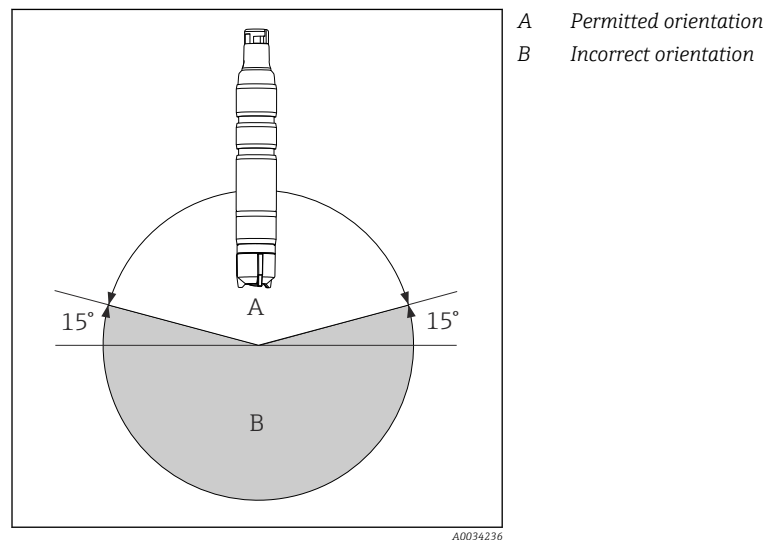

#### 5.1.2 Immersion depth

At least 50 mm (1.97 in).

This corresponds to the mark (▼) on the sensor.

### 5.1.3 Dimensions

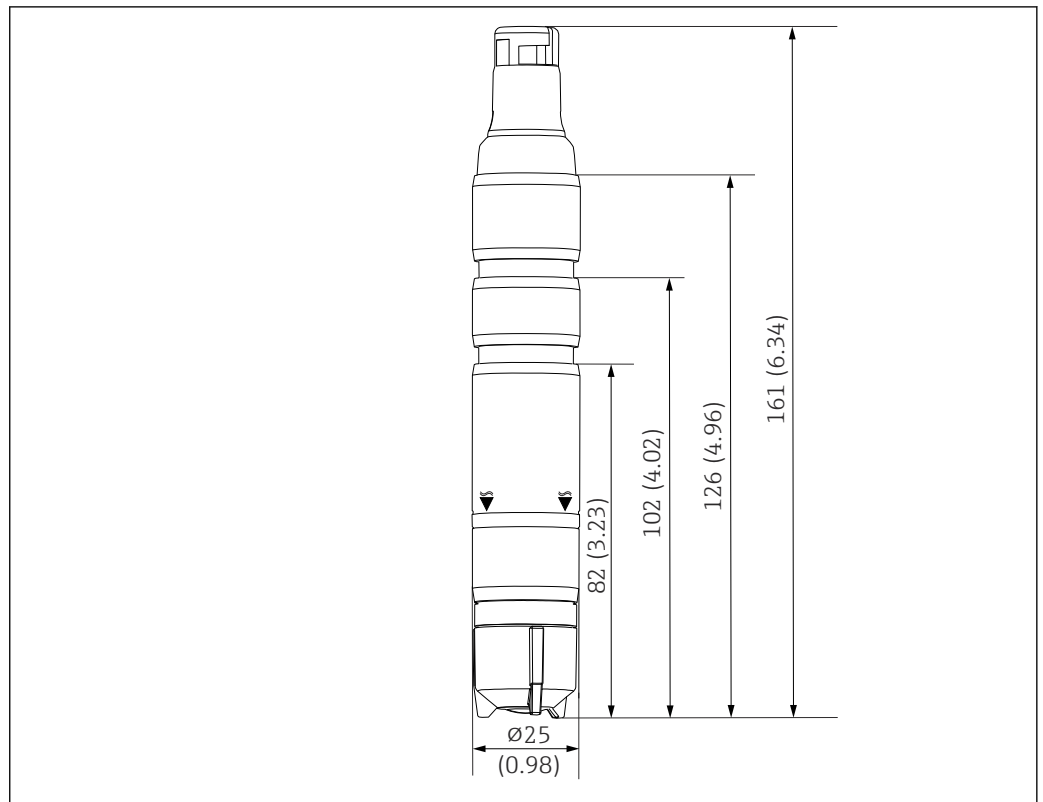

2 Dimensions in mm (in)

A0045241

## 5.2 Mounting the sensor

### 5.2.1 Measuring system

A complete measuring system comprises:

- Disinfection sensor CCS53E (membrane-covered,  $\varnothing 25$  mm) with appropriate mounting adapter
- Flowfit CYA27 flow assembly
- Measuring cable CYK10, CYK20
- Transmitter, e.g. Liquiline CM44x with firmware 01.13.00 or higher or CM44xR with firmware 01.13.00 or higher
- Optional: extension cable CYK11
- Optional: proximity switch
- Optional: Flexdip CYA112 immersion assembly

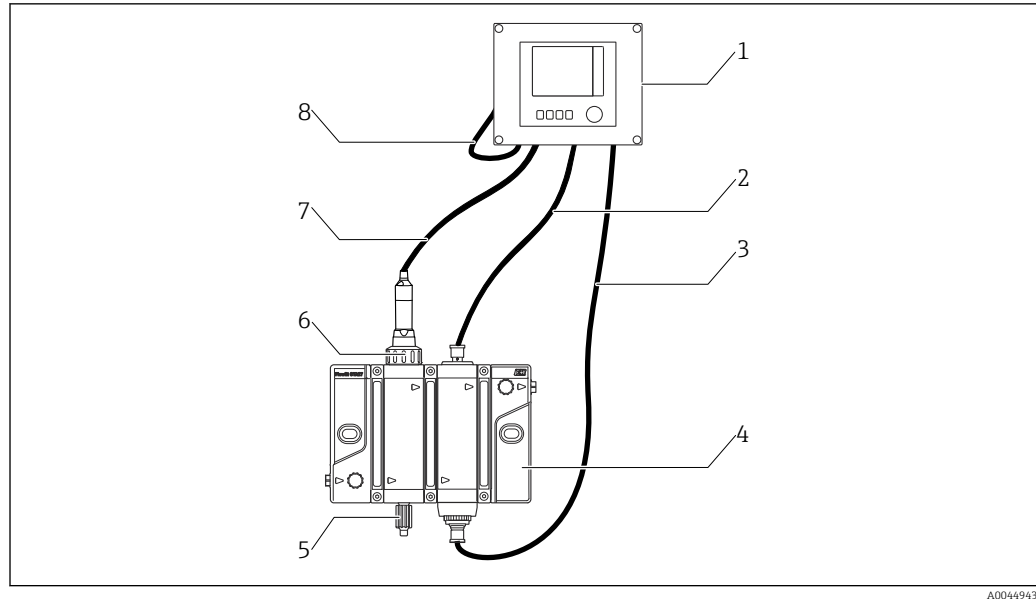

A0044943

3 Example of a measuring system

- 1 Transmitter Liquiline CM44x or CM44xR
- 2 Cable for inductive switch
- 3 Cable for status lighting on assembly
- 4 Flowfit CYA27 flow assembly
- 5 Sampling valve
- 6 Disinfection sensor Memosens CCS53E (membrane-covered,  $\varnothing 25$  mm)
- 7 Measuring cable CYK10
- 8 Power supply cable Liquiline CM44x or CM44xR

## 5.2.2 Preparing the sensor

### Remove protection cap from sensor

#### NOTICE

#### Negative pressure causes damage to the sensor's membrane cap

- ▶ When supplied to the customer and when in storage, the sensor is fitted with a protection cap.
- ▶ Release the top part of the protection cap by turning it.

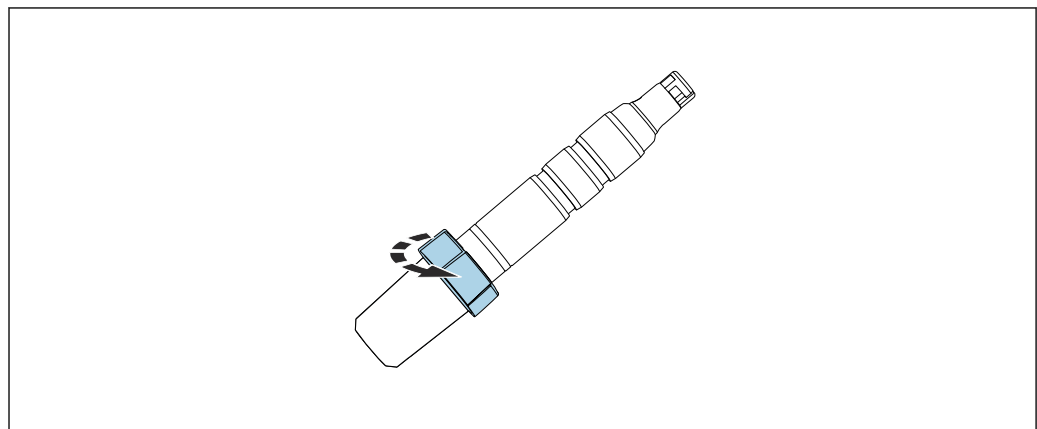

A0034263

- ▶ Carefully remove the protection cap from the sensor.

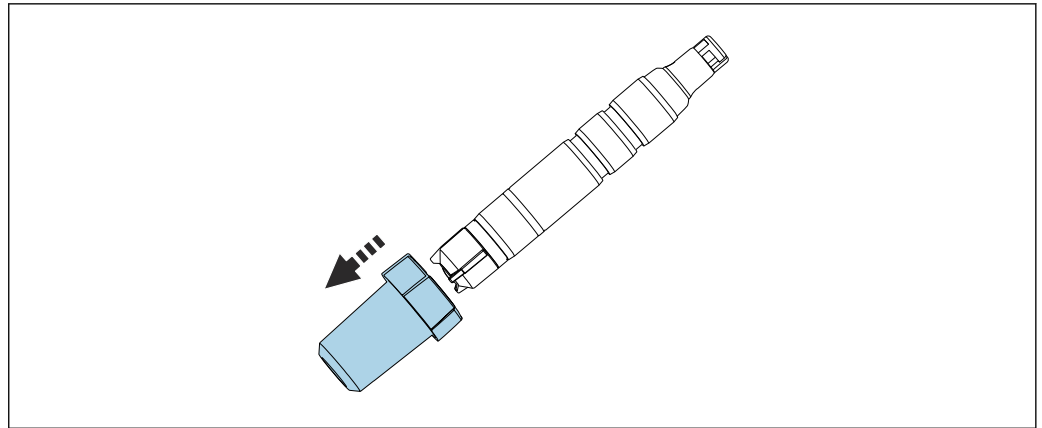

A0034350

### 5.2.3 Installing the sensor in the Flowfit CYA27 assembly

The sensor can be installed in the Flowfit CYA27 flow assembly. In addition to the installation of the total chlorine sensor, this assembly also enables the simultaneous operation of several other sensors and flow monitoring.

Please note the following during installation:

- ▶ Guarantee the minimum flow to the sensor 15 cm/s (0.49 ft/s) and the minimum volume flow of the assembly (5 l/h or 30 l/h).
- ▶ If the medium is fed back into an overflow basin, pipe or similar, the resulting counterpressure on the sensor may not exceed 1 bar relativ (14.5 psi relativ) (2 bar abs. (29 psi abs.)) and must remain constant.
- ▶ Avoid negative pressure at the sensor, e.g. due to medium being returned to the suction side of a pump.
- ▶ To avoid buildup, heavily contaminated water should also be filtered.

#### Fit sensor with adapter

The necessary adapter (clamping ring, thrust collar and O-ring) can be ordered as a mounted accessory for the sensor or as a separate accessory.

- ▶ First mount the clamping ring (1) from the sensor head towards the membrane cap, then slide the thrust collar (2) and then the O-ring (3) from the membrane cap towards the sensor head as far as the lower groove.

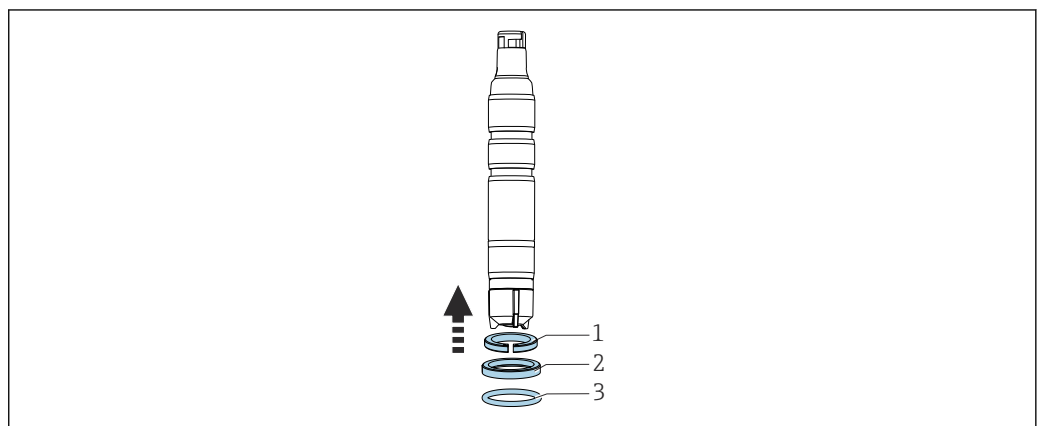

A0034247

#### Install sensor in assembly

1. The assembly is supplied to the customer with a union nut screwed onto the assembly; unscrew union nut from assembly.

2. The assembly is supplied to the customer with a dummy plug inserted in the assembly: remove dummy plug and O-ring (1) from the assembly.
3. Slide the sensor with the adapter for Flowfit CYA27 into the opening in the assembly.
4. Screw the union nut onto the assembly.

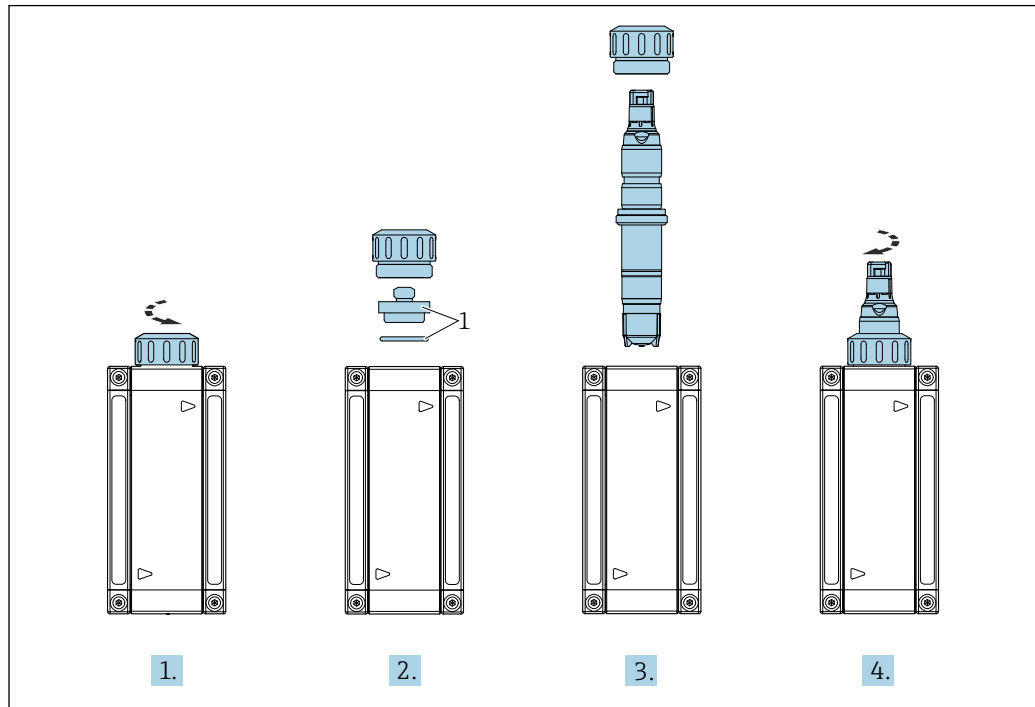

A0043536

1 Dummy plug and O-ring

#### 5.2.4 Installing the sensor in flow assemblies

When using other flow assemblies, please ensure the following:

- ▶ A minimum flow velocity of 15 cm/s (0.49 ft/s) must be ensured at the membrane.
- ▶ The flow direction is upwards. Transported air bubbles must be removed so that they do not collect in front of the membrane.
- ▶ The membrane must be exposed to direct flow.

#### 5.2.5 Installing the sensor in immersion assembly CYA112

Alternatively, the sensor can be installed in an immersion assembly with a G1" threaded connection.

 Additional installation instructions can be found in the Operating Instructions for the assembly: [www.endress.com/cya112](http://www.endress.com/cya112)

 Ensure sufficient flow towards the sensor when using the immersion assembly .



**Fit sensor with adapter**

The required adapter can be ordered as a mounted sensor accessory or as a separate accessory.

1.

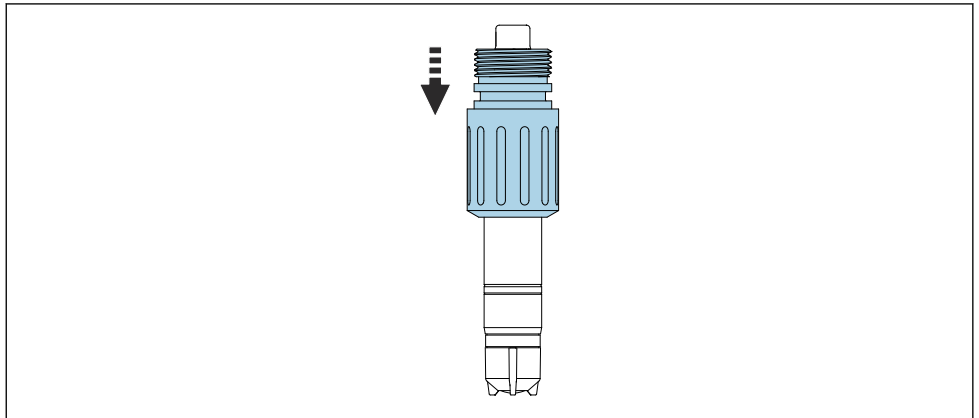

A0034246

Starting from the sensor head, slide the adapter for Flexdip CYA112 onto the sensor as far as the end stop.

2.

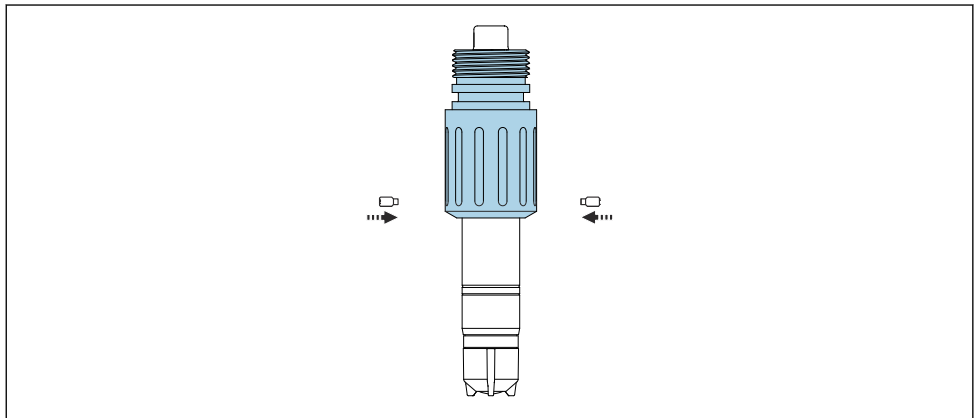

A0044635

Fix the adapter with the 2 stud screws supplied and an Allen screw (2 mm (0.08 in)).

3. Screw the sensor into the assembly. The use of a quick release fastener is recommended.



For detailed information on installing the sensor in Flexdip CYA112 assembly, see Operating Instructions for assembly [www.endress.com/cya112](http://www.endress.com/cya112)

Operating Instructions BA00432C

## 6 Electrical connection

### **⚠ CAUTION**

#### Device is live

Incorrect connection may result in injury!

- ▶ The electrical connection may be performed only by an electrical technician.
- ▶ The electrical technician must have read and understood these Operating Instructions and must follow the instructions contained therein.
- ▶ **Prior** to commencing connection work, ensure that no voltage is present on any cable.

### 6.1 Connecting the sensor

is electrically connected to the transmitter is performed via the Memosens data cable CYK10.

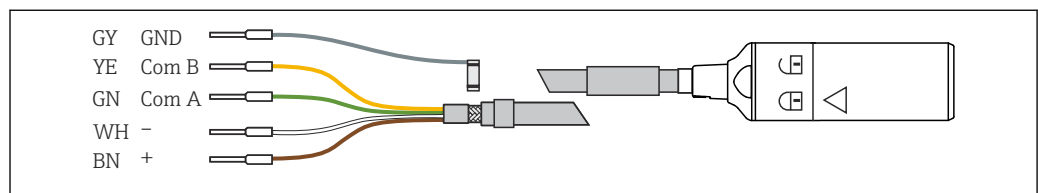

A0024019

4 Measuring cable CYK10

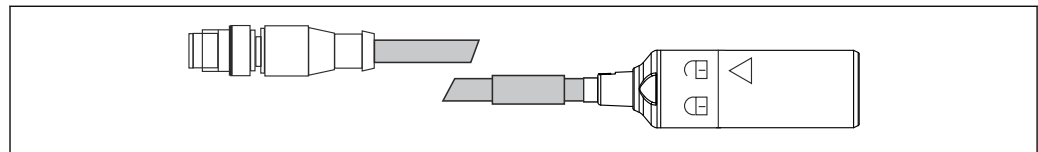

A0018861

5 CYK10 with M12 plug, electrical connection

### 6.2 Ensuring the degree of protection

Only the mechanical and electrical connections which are described in these instructions, and which are necessary for the required intended use, may be established on the device delivered.

- ▶ Exercise care when carrying out the work.

Otherwise, the individual types of protection (Ingress Protection (IP), electrical safety, EMC interference immunity) agreed for this product can no longer be guaranteed due, for example, to covers being left off or cable (ends) that are loose or insufficiently secured.

### 6.3 Post-connection check

Device condition and specifications	Action
Are the sensor, assembly or cables free from damage on the outside?	▶ Perform a visual inspection.
Electrical connection	Action
Are the mounted cables strain-relieved and not twisted?	▶ Perform a visual inspection. ▶ Untwist the cables.
Is a sufficient length of the cable cores stripped, and are the cores positioned in the terminal correctly?	▶ Perform a visual inspection. ▶ Pull gently to check they are seated correctly.
Are all screw terminals tightened?	▶ Tighten the screw terminals.

Device condition and specifications	Action
Are all the cable entries installed, tightened and leak-tight?	<ul style="list-style-type: none"> <li>▶ Perform a visual inspection.</li> </ul> In the case of lateral cable entries:
Are all cable entries mounted on the side or pointing downwards?	<ul style="list-style-type: none"> <li>▶ Point cable loops downward so that water can drip off.</li> </ul>

## 7 Commissioning

### 7.1 Post-installation check and function check

Before commissioning, ensure that:

- The sensor is correctly installed
- The electrical connection is correct
- There is sufficient electrolyte in the membrane cap and the transmitter is not displaying a warning about electrolyte depletion



Please note the information on the safety data sheet to ensure safe use of the electrolyte.



Always keep the sensor moist after commissioning.

#### **⚠ WARNING**

##### **Escaping process medium**

Risk of injury from high pressure, high temperatures or chemical hazards

- ▶ Before applying pressure to an assembly with cleaning system, ensure that the system has been connected correctly.
- ▶ Do not install the assembly in the process if you cannot reliably establish the correct connection.

### 7.2 Sensor polarization

A voltage is applied between the working electrode and counterelectrode when connecting to the transmitter. The electrode is polarized. The processes that occur during polarization affect the measuring signal. You must therefore wait until the polarization period has elapsed before starting calibration.

To achieve a stable display value, the sensor requires the following polarization times:

Initial commissioning	45 min
Recommissioning	20 min

### 7.3 Calibrating the sensor

#### **Reference measurement according to the DPD method**

To calibrate the measuring system, carry out a colorimetric comparison measurement in accordance with the DPD method. Chlorine dioxide reacts with diethyl-p-phenyldiamine (DPD) producing a red dye, the intensity of the red color being proportional to the chlorine dioxide content.

Measure the intensity of the red color using a photometer, (e.g. PF-3 ). The photometer indicates the chlorine dioxide content.

#### **Requirements**

The sensor reading is stable (no drifts or unsteady values for at least 5 minutes). This is normally guaranteed once the following preconditions have been met:

- The polarization time has elapsed.
- The flow is constant and within the correct range.
- The sensor and the medium are at the same temperature.
- The pH value is within the permitted range.

#### **Zero point adjustment**

A zero point adjustment is not required due to the zero point stability of the membrane-covered sensor.

However, a zero point adjustment can be performed if desired.

1. To perform a zero point adjustment, operate the sensor for at least 15 min. in chlorine dioxide-free water, using the assembly or protection cap as a vessel.
2. Alternatively, perform the zero point adjustment using the zero point gel COY8 .

### Slope calibration

Always perform a slope calibration in the following cases:

- After replacing the membrane cap
  - After replacing electrolyte
1. Ensure that the pH value and temperature of the medium are constant.
  2. Take a representative sample for the DPD measurement. This must be done in close proximity to the sensor. Use the sampling tap if available.
  3. Determine the total chlorine context using the DPD method.
  4. Enter the measured value into the transmitter (see Operating Instructions for transmitter).
  5. To ensure greater accuracy, check the calibration several hours or 24 hours later using the DPD method.

## 7.4 Electrolyte counter

The electrolyte counter monitors the consumption of the electrolyte in the sensor membrane cap over time. Warning message M505 of the Liquiline transmitter serves as an aid for timely sensor maintenance. The warning limit can be configured individually.

### Activating the electrolyte counter and warning limit

1. Go to **Menu/Setup/Inputs/<Sensor Disinfection>/Extended setup/Diagnostics settings** and select **Electrolyte counter**.
2. Select **Function: On**.
3. Under **Warning limit**, set the value in accordance with the custom maintenance plan. The default setting is restored by resetting to the factory settings.

### Reading out the electrolyte counter

1. Go to **Menu/Diagnostics/Sensor information/<Sensor Disinfection>/Sensor operation**.
2. Read out **Charge**.

## 8 Diagnostics and troubleshooting

When troubleshooting, the entire measuring point must be taken into account. This comprises:

- Transmitter
- Electrical connections and lines
- Assembly
- Sensor

The possible causes of errors in the following table refer primarily to the sensor. Before commencing troubleshooting, ensure that the following operating conditions have been met:

- Measurement in "temperature-compensated" mode (can be configured on the CM44x transmitter) or constant temperature following calibration
- Flow velocity of at least 15 cm/s (0.5 ft/s)
- No other disinfectants used

### NOTICE

- ▶ If the value measured by the sensor differs significantly from that of the DPD method, first consider all possible malfunctions of the photometric DPD method (see Operating Instructions for photometer). If necessary, repeat the DPD measurement several times.

Error	Possible cause	Remedial action
No display, no sensor current	No supply voltage at the transmitter	▶ Establish mains connection
	Connection cable between sensor and transmitter interrupted	▶ Establish cable connection
	There is no electrolyte in the membrane cap	▶ Fill membrane cap
	No input flow of medium	▶ Establish flow, clean filter
Display value too high	Polarization of the sensor not yet completed	▶ Wait for polarization to be completed
	Membrane defective	▶ Replace membrane cap
	Shunt (e.g. moisture contact) in the sensor shaft	▶ Remove membrane cap ▶ Rub the working electrode to dry ▶ If the transmitter display does not return to zero, there is a shunt present: replace sensor
	Foreign oxidants interfering with sensor	▶ Examine medium, check chemicals

Error	Possible cause	Remedial action
Display value too low	Membrane cap not screwed on fully	<ul style="list-style-type: none"> <li>▶ Fill membrane cap with fresh electrolyte</li> <li>▶ Screw membrane cap on fully</li> </ul>
	Membrane soiled	▶ Clean membrane
	Air bubble in front of membrane	▶ Release air bubble
	Air bubble between working electrode and membrane	<ul style="list-style-type: none"> <li>▶ Remove membrane cap, top up electrolyte</li> <li>▶ Remove air bubble by tapping on the outside of the membrane cap</li> <li>▶ Screw on membrane cap</li> </ul>
	Input flow of medium too low	▶ Establish correct flow
	Foreign oxidants interfering with DPD reference measurement	▶ Examine medium, check chemicals
	Use of organic disinfectants	<ul style="list-style-type: none"> <li>▶ Use suitable agent (e.g. as per DIN 19643) (water may need to be replaced first)</li> <li>▶ Use suitable reference system</li> </ul>
Display fluctuates considerably	Hole in membrane	▶ Replace membrane cap

## 9 Maintenance



Please note the information on the safety data sheet to ensure safe use of the electrolyte.

Take all the necessary precautions in time to ensure the operational safety and reliability of the entire measuring system.

### NOTICE

#### Effects on process and process control!

- ▶ When carrying out any work on the system, bear in mind any potential impact this could have on the process control system and the process itself.
- ▶ For your own safety, only use genuine accessories. With genuine parts, the function, accuracy and reliability are also ensured after maintenance work.

### 9.1 Maintenance schedule

Interval	Maintenance work
If deposits are visible on the membrane (biofilm, limescale)	▶ Clean sensor membrane →  25
If dirt is visible on the surface of the electrode body	▶ Clean electrode body of sensor →  25
<ul style="list-style-type: none"> <li>▪ Slope depending on application:               <ul style="list-style-type: none"> <li>▪ Every 12 months (at maximum) if conditions remain constant in the permitted range of 0 to 55 °C (32 to 131 °F)</li> <li>▪ In the case of severe temperature fluctuations, e.g. from 10 °C (50 °F) to 25°C (77 °F) and back</li> </ul> </li> <li>▪ Zero point calibration:               <ul style="list-style-type: none"> <li>▪ If operated in concentration range below 0.5 mg/l (ppm)</li> <li>▪ If negative measured value is displayed with factory calibration</li> </ul> </li> </ul>	▶ Calibrate sensor
<ul style="list-style-type: none"> <li>▪ If electrolyte counter warning is active</li> <li>▪ If cap is replaced</li> <li>▪ For determining the zero point</li> <li>▪ If the slope is too low or too high relative to the nominal slope and the membrane cap is not visibly damaged or dirty</li> </ul>	▶ Fill membrane cap with fresh electrolyte →  24
<ul style="list-style-type: none"> <li>▪ If there are grease/oil deposits (dark or transparent spots on the membrane)</li> <li>▪ If slope is too high or too low or sensor current is very noisy</li> <li>▪ If it is obvious that the sensor current is significantly dependent on the temperature (temperature compensation not working).</li> </ul>	▶ Replace membrane cap →  26
If changes are visible on the working electrode or counter electrode (brown coating no longer present)	▶ Regenerate sensor →  29

### 9.2 Maintenance work

#### 9.2.1 Cleaning the sensor

##### CAUTION

##### Diluted hydrochloric acid

Hydrochloric acid causes irritation if it comes into contact with the skin or eyes.

- ▶ When using diluted hydrochloric acid, wear protective clothing such as gloves and goggles.
- ▶ Avoid splashes.



**NOTICE****Chemicals that reduce surface tension (e.g. surfactants in cleaning agents or organic solvents that can be mixed with water, such as alcohol)**

Chemicals that reduce the surface tension cause the sensor membrane to lose its special property and protective function, which results in measurement errors.

- ▶ Do not use any chemicals that reduce surface tension.

**Remove the sensor from the Flowfit CYA27 assembly**

1. Remove the cable.
2. Unscrew the union nut from the assembly.
3. Pull sensor out through opening in assembly.

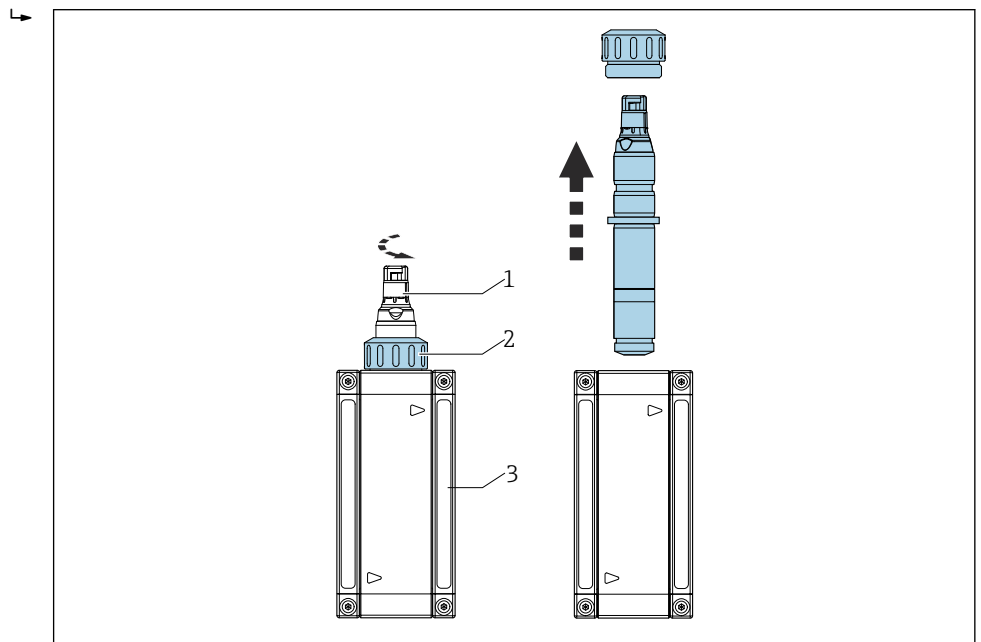

- 1 Disinfection sensor  
 2 Union nut for securing a disinfection sensor  
 3 Flowfit CYA27 flow assembly



For detailed information on "Removing the sensor from the Flowfit CYA27 assembly," see the Operating Instructions for the assembly. [www.endress.com/cya27](http://www.endress.com/cya27)

Operating Instructions BA02059C

**Clean the sensor membrane**

If the membrane is visibly dirty, e.g. biofilm, proceed as follows:

1. Remove the sensor from the flow assembly .
2. Remove the membrane cap → 26.
3. Clean the membrane cap mechanically only using a gentle water jet. Alternatively, clean for several minutes in diluted acids or in specified cleaning agents without any further chemical additives.
4. Then rinse thoroughly with water.
5. Screw the membrane cap back onto the sensor → 26.

**Clean the electrode body**

1. Remove sensor from flow assembly.
2. Remove membrane cap → 26.

3. Wipe gold electrode carefully using a soft sponge.
4. Rinse electrode body with demineralized water, alcohol or acid.
5. Fill the membrane cap with fresh electrolyte.
6. Screw the membrane cap back onto the sensor →  26.

### 9.2.2 Filling the membrane cap with fresh electrolyte



Please note the information on the safety data sheet to ensure safe use of the electrolyte.



#### NOTICE

##### Damage to membrane and electrodes, air bubbles



Possibility of measured errors to complete failure of the measuring point

- ▶ Avoid damage to membrane and electrodes.
- ▶ The electrolyte is chemically neutral and is not hazardous to health. Nonetheless, do not swallow it and avoid contact with eyes.
- ▶ Keep the electrolyte bottle closed after use. Do not transfer electrolyte to other vessels.
- ▶ Do not store electrolyte for longer than 2 years. The electrolyte must not be yellow in color. Observe the use-by date on the label.
- ▶ Avoid air bubbles when pouring electrolyte into membrane cap.

##### Fill membrane cap with electrolyte

1. Remove the membrane cap →  26.
2. Fill approx. 7 ml (0.24 fl oz) of electrolyte into the membrane cap until it is level with the start of the internal thread.
3. Slowly screw on the membrane cap as far as the end stop →  25. This will cause excess electrolyte to be displaced at the valve and thread.
4. If necessary, pat the sensor and membrane cap dry using a cloth.
5. Reset operating hours counter for electrolyte on transmitter under **Menu/Calibration/<Sensor disinfection>/Disinfection/Change electrolyte or Change sensor cap and electrolyte/Save**

### 9.2.3 Replacing the membrane cap

1. Remove the sensor from the flow assembly .
2. Remove the membrane cap →  26.
3. Pour fresh electrolyte into the new membrane cap until it is level with the start of the female thread.
4. Check if the sealing ring is mounted in the membrane cap.
5. Screw the new membrane cap onto the sensor shaft →  26.
6. Screw on the membrane cap until the membrane at the working electrode is slightly overstretched (1 mm (0.04 in)).
7. Reset operating hours counter for membrane cap on transmitter. For detailed information, see the Operating Instructions for the transmitter.

**Remove membrane cap**

- ▶ Carefully rotate membrane cap.

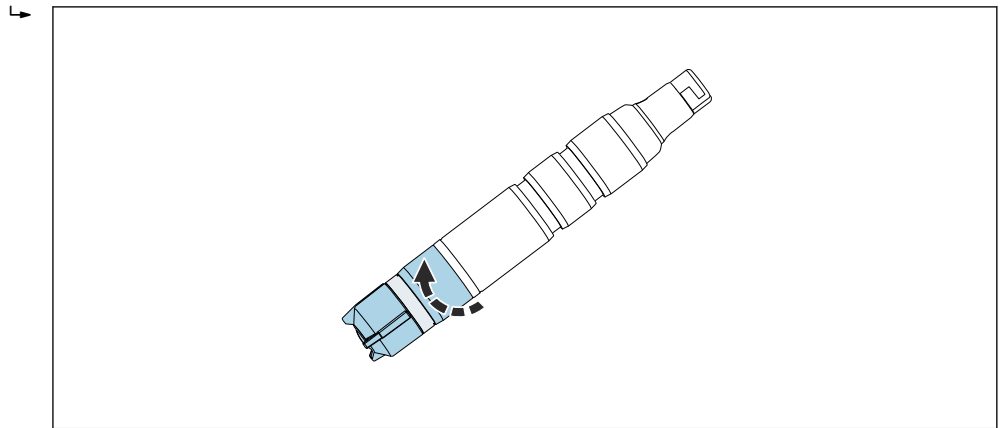

A0034406

- ▶ Carefully remove membrane cap.

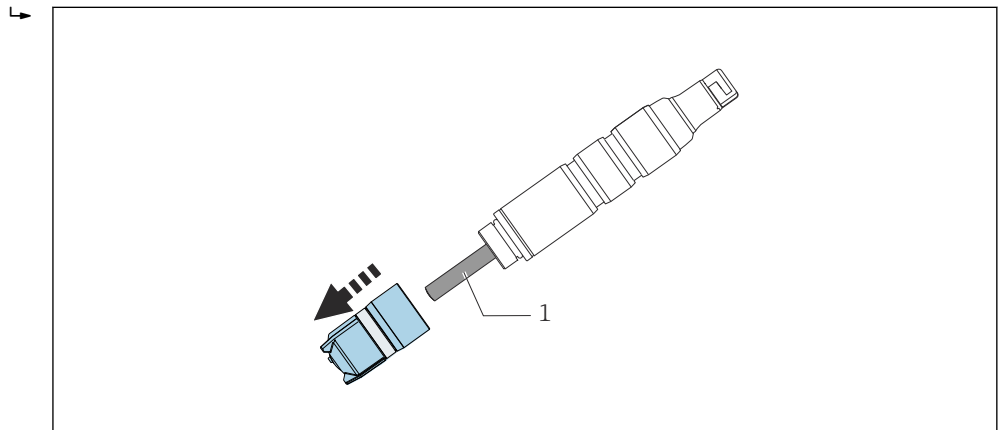

A0034408

1 Electrode body

**Screw membrane cap onto sensor**

- ▶ Screw membrane cap onto sensor shaft: hold sensor by the shaft.

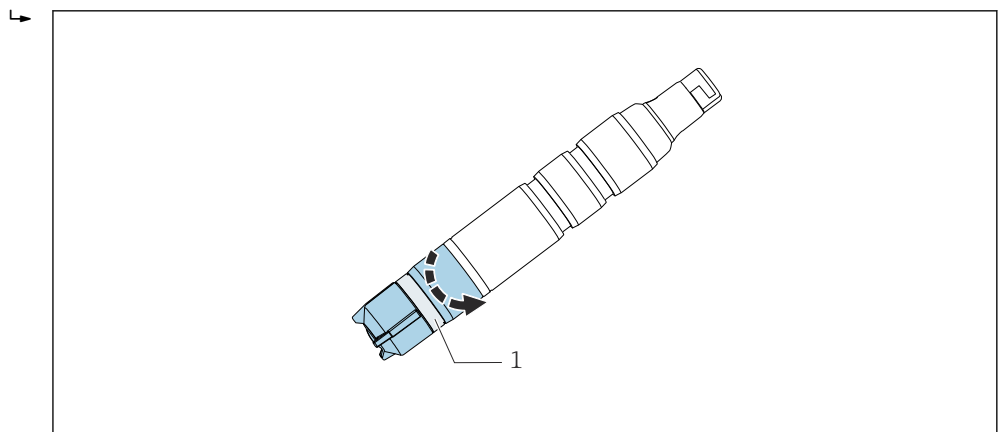

A0034480

6 Screw on membrane cap: keep pressure relief valve clear.



1 Pressure relief valve

### 9.2.4 Storing the sensor

If measurement is suspended for a short period of time and it can be guaranteed that the sensor will be kept moist while in storage:

1. The assembly is guaranteed not to empty out, you may leave the sensor in the flow assembly.
2. There is a possibility that the assembly may empty out, remove the cable and remove the sensor from the assembly.
3. To keep the membrane moist after the sensor has been removed, refill the protection cap with electrolyte or clean water.
4. Fit the protection cap on the sensor →  28.

During longterm interruptions to measurement, particularly if dehydration is possible:

1. Remove the cable.
2. Remove the sensor from the assembly .
3. Clean sensor shaft and membrane cap with cold water and leave to dry.
4. Loosely screw on the membrane cap as far as the end stop. This ensures that the membrane remains slack.
5. Put on the dry protective cap for mechanical protection →  26.
6. When recommissioning the device, fill electrolyte into the membrane cap →  26 and then follow the steps for commissioning →  20.

Ensure that no biofouling occurs during longer interruptions to measurement:

- ▶ Remove continuous organic deposits, such as films of bacteria.

#### Fit the protection cap on the sensor

1. To keep the membrane moist after the sensor has been removed, refill the protection cap with electrolyte or clean water.
2. Top part of protection cap is in the open position. Carefully slide protection cap onto the membrane cap.

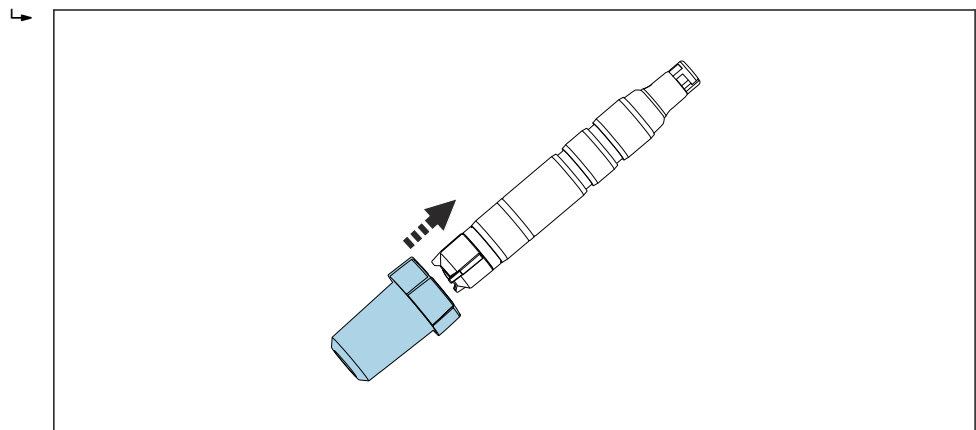

A0034264

3. Secure protection cap by rotating the top part of the protection cap.

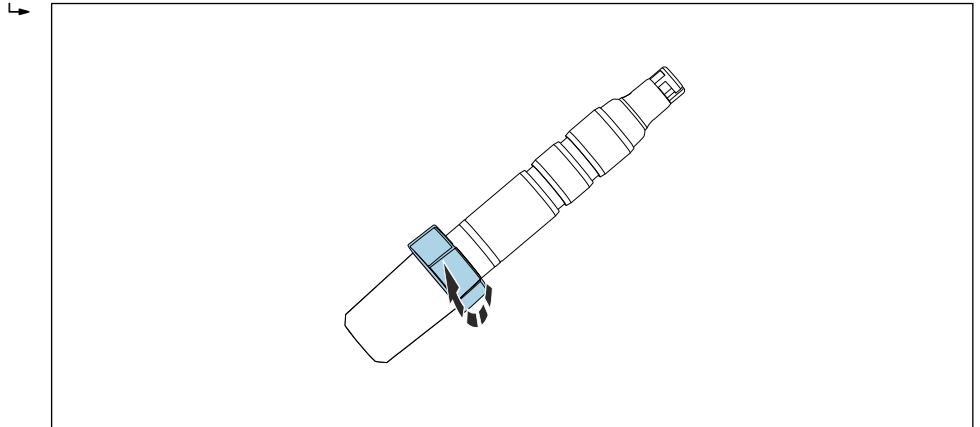

A0034494

### 9.2.5 Regenerating the sensor

During measurement, the electrolyte in the sensor is gradually exhausted due to chemical reactions. The gray-brown silver chloride layer that is applied to the counter electrode at the factory continues to grow during sensor operation. This has no effect on the reaction taking place at the working electrode.

A change in the color of the silver chloride layer indicates an effect of the reaction that is taking place.

1. Carry out a visual inspection to ensure that the gray-brown color of the counter electrode has not changed. If the color of the counter electrode has changed, e.g. if it is spotted, white or silvery, the sensor must be regenerated.
2. Send the sensor to the manufacturer for regeneration.

## 10 Repair

### 10.1 Spare parts

For more detailed information on spare parts kits, please refer to the "Spare Part Finding Tool" on the Internet:

[www.endress.com/spareparts\\_consumables](http://www.endress.com/spareparts_consumables)

### 10.2 Return

The product must be returned if repairs or a factory calibration are required, or if the wrong product was ordered or delivered. As an ISO-certified company and also due to legal regulations, Endress+Hauser is obliged to follow certain procedures when handling any returned products that have been in contact with medium.

To ensure the swift, safe and professional return of the device:

- ▶ Refer to the website [www.endress.com/support/return-material](http://www.endress.com/support/return-material) for information on the procedure and conditions for returning devices.

### 10.3 Disposal



If required by the Directive 2012/19/EU on waste electrical and electronic equipment (WEEE), the product is marked with the depicted symbol in order to minimize the disposal of WEEE as unsorted municipal waste. Do not dispose of products bearing this marking as unsorted municipal waste. Instead, return them to the manufacturer for disposal under the applicable conditions.

## 11 Accessories

The following are the most important accessories available at the time this documentation was issued.

Listed accessories are technically compatible with the product in the instructions.

1. Application-specific restrictions of the product combination are possible.  
Ensure conformity of the measuring point to the application. This is the responsibility of the operator of the measuring point.
2. Pay attention to the information in the instructions for all products, particularly the technical data.
3. For accessories not listed here, please contact your Service or Sales Center.

### 11.1 Maintenance kit CCV05

Order according to product structure

- 2 x membrane caps and 1 x electrolyte 50 ml (1.69 fl oz)
- 1 x electrolyte 50 ml (1.69 fl oz)
- 2 x sealing set

### 11.2 Device-specific accessories

#### Memosens data cable CYK10

- For digital sensors with Memosens technology
- Product Configurator on the product page: [www.endress.com/cyk10](http://www.endress.com/cyk10)

 Technical Information TI00118C

#### Memosens data cable CYK11

- Extension cable for digital sensors with Memosens protocol
- Product Configurator on the product page: [www.endress.com/cyk11](http://www.endress.com/cyk11)

 Technical Information TI00118C

#### Memosens laboratory cable CYK20

- For digital sensors with Memosens technology
- Product Configurator on the product page: [www.endress.com/cyk20](http://www.endress.com/cyk20)

#### Flowfit CYA27

- Modular flow assembly for multiparameter measurements
- Product Configurator on the product page: [www.endress.com/cya27](http://www.endress.com/cya27)

 Technical Information TI01559C

#### Flexdip CYA112

- Immersion assembly for water and wastewater
- Modular assembly system for sensors in open basins, channels and tanks
- Material: PVC or stainless steel
- Product Configurator on the product page: [www.endress.com/cya112](http://www.endress.com/cya112)

 Technical Information TI00432C

#### Photometer PF-3

- Compact hand-held photometer for determining the reference measured value
- Color-coded reagent bottles with clear dosing instructions
- Order No.: 71257946

**Adapter kit CCS5x(D/E) for CYA27**

- Clamping ring
- Thrust collar
- O-ring
- Order No. 71372027

**Adapter kit CCS5x(D/E) for CYA112**

- Adapter incl. O-rings
- 2 studs for locking in place
- Order No. 71372026

**Complete quick fastener kit for CYA112**

- Adapter, inner and outer parts incl. O-rings
- Tool for mounting and disassembly
- Order No. 71093377 or mounted accessory of CYA112

**COY8**

Zero-point gel for oxygen and disinfection sensors

- Disinfectant-free gel for the verification, zero point calibration and adjustment of oxygen and disinfection measuring points
- Product Configurator on the product page: [www.endress.com/coy8](http://www.endress.com/coy8)



Technical Information TI01244C



## 12 Technical data

### 12.1 Input

Measured variables	Total chlorine	[mg/l, µg/l, ppm, ppb] <ul style="list-style-type: none"> <li>■ Free available chlorine: <ul style="list-style-type: none"> <li>■ Hypochlorous acid (HOCl)</li> <li>■ Hypochlorite ions (OCl<sup>-</sup>)</li> </ul> </li> <li>■ Combined chlorine (chloramines)</li> <li>■ Organically combined chlorine (e.g. cyanuric acid derivatives)</li> </ul>
	Temperature	[°C, °F]
Measuring range	CCS53E-**11AD**	0 to 5 mg/l (ppm) total chlorine
	CCS53E-**11BF**	0 to 20 mg/l (ppm) total chlorine
Signal current	CCS53E-**11AD**	8 to 20 nA per 1 mg/l (ppm) HOCl
	CCS53E-**11BF**	8 to 20 nA per 1 mg/l (ppm) HOCl

### 12.2 Performance characteristics

Reference operating conditions	Temperature	20 °C (68 °F)	
	pH value	pH 7.5 ±0.2	
	Flow	40 to 60 cm/s	
	HOCl-free base medium	Mains water	
Response time	T <sub>90</sub> < 180 s (after completing polarization)		
Polarization time	Initial commissioning	45 min	
	Recommissioning	20 min	
Measured value resolution of sensor	At most, the smallest possible measured value resolution under reference conditions is 0.05 % of the measured value above the limit of quantification (LOQ).		
Measured error		LOD (limit of detection) <sup>1)</sup>	LOQ (limit of quantification)
	CCS53E-**11AD**	0.008 mg/l (ppm) HOCl	0.028 mg/l (ppm) HOCl
	CCS53E-**11BF**	0.008 mg/l (ppm) HOCl	0.028 mg/l (ppm) HOCl
1) Based on ISO 15839. The measured error includes all the uncertainties of the sensor and transmitter (electrode system). It does not contain all the uncertainties caused by the reference material and adjustments that may have been performed.			
Repeatability	CCS53E-**11AD**	0.004 mg/l (ppm)	
	CCS53E-**11BF**	0.007 mg/l (ppm)	

Nominal slope	CCS53E-**11AD**	11 nA per 1 mg/l (ppm) HOCl
	CCS53E-**11BF**	11 nA per 1 mg/l (ppm) HOCl
Long-term drift	< 1 % per month (mean value, determined while operating at varying concentrations and under reference conditions)	
Operating time of the electrolyte	at 10 % of measuring range and 20 °C	2 years
	at 50 % of measuring range and 20 °C	1 year
	at maximum concentration and 55 °C	60 days

**Intrinsic consumption**

The intrinsic consumption of chlorine at the sensor is negligible.

**12.3 Environment**

Ambient temperature -20 to 60 °C (-4 to 140 °F)

Storage temperature		<b>Long-term storage up to 2 years (maximum)</b>	<b>Storage up to 48 h (maximum)</b>
	With electrolyte	0 to 35 °C (32 to 95 °F) (non-freezing)	35 to 55 °C (95 to 131 °F)
	Without electrolyte	-20 to 60 °C (-4 to 140 °F)	

Degree of protection IP68 (1.8 m (5.91 ft)) water column over 7 days at 20 °C (68 °F)

**12.4 Process**

Process temperature 0 to 55 °C (32 to 130 °F), non-freezing

Pressure The inlet pressure depends on the specific fitting and installation.  
The measurement can take place with a free outlet.  
The sensor can be operated at process pressures up to 1 bar relativ (14.5 psi relativ) (2 bar abs. (29 psi abs.)).

pH range	Range of effectiveness of total chlorine	pH 4 to 9 <sup>1)</sup>
	Calibration	pH 4 to 9
	Measurement	pH 4 to 9

1) Up to pH 4 and in the presence of chloride ions (Cl<sup>-</sup>), Cl<sub>2</sub> is produced which is also measured

Conductivity The sensor can also be used in media with a very low conductivity, such as demineralized water.

Flow At least 5 l/h (1.3 gal/h), in the Flowfit CYA27 flow assembly (5 l version)  
At least 30 l/h (7.9 gal/h), in the Flowfit CYA27 flow assembly (30 l version)

Flow At least 15 cm/s (0.5 ft/s) , e.g. with Flexdip CYA112 immersion assembly

- In terms of sensor condition and performance, it is essential that the flow velocity limits specified in the following table be observed.

	Flow velocity [cm/s]	Volume flow [l/h]		
		Flowfit CYA27 (5 l version)	Flowfit CYA27 (30 l version)	Flexdip CYA112
Minimum	15	5	30	The sensor is suspended freely in the medium; pay attention to the minimum flow velocity of 15 cm/s during installation.
Maximum	80	30	60	

## 12.5 Mechanical construction

Dimensions →  13

Weight Sensor with membrane cap and electrolyte (without protection cap and without adapter)  
Approx. 95 g (3.35 oz)

Materials	Sensor shaft	POM
	Membrane	PET/PVDF
	Membrane cap	PVDF
	Protection cap	<ul style="list-style-type: none"> <li>■ Vessel: PC Makrolon (polycarbonate)</li> <li>■ Seal: Kraiburg TPE TM5MED</li> <li>■ Cover: PC Makrolon (polycarbonate)</li> </ul>
	Sealing ring	FKM
	Sensor shaft coupling	PPS

Cable specification max. 100 m (330 ft), incl. Cable extension



71644385

[www.addresses.endress.com](http://www.addresses.endress.com)

---