

Installation Instructions

Flow assembly kit for CFS51

Retrofit kit / replacement for flow assembly of
CFS51



Table of contents

1	Overview of spare part sets	3
2	Intended use	3
3	Authorized installation personnel	3
4	Safety instructions	4
5	Symbols	5
6	Scope of delivery	6
7	Tool list	12
8	Mounting	13
9	Replacing the spare part kits	27
10	Disposal	37

1 Overview of spare part sets

Order code	Original spare part kit
71546713	Kit CFS51 flow assembly scrubber
71546714	Kit CFS51 assembly scrubber seal kit
71546718	Kit CFS51 coupling nut and ring clip
71546716	Kit CFS51 titanium sensor adapter
71546719	Kit CFS51 2x adapter G1/4 -8 mm (0.31 in) OD PVDF
71546721	Kit CFS51 cleaning adapter PVDF
71546722	Kit CFS51 check valve 6 mm (0.24 in) OD PVDF
71546723	Kit CFS51 2x hose support DN6/8

2 Intended use

The flow assembly is designed exclusively for installing optical sensor CFS51.

The assembly is designed exclusively for use in liquid media.

Use of the device for any purpose other than that described, poses a threat to the safety of people and of the entire measuring system and is therefore not permitted.

The manufacturer is not liable for damage caused by using the device incorrectly or for purposes for which it was not intended.

3 Authorized installation personnel

- Installation, commissioning, operation and maintenance of the measuring system may be carried out only by specially trained technical personnel.
- The technical personnel must be authorized by the plant operator to perform the stated tasks.
- The electrical connection may be performed only by an electrical technician.
- The technical personnel must have read and understood the Operating Instructions and must follow the instructions contained therein.
- Measuring point faults may be repaired only by authorized and specially trained personnel.

 Repairs not described in the Operating Instructions provided must only be carried out directly by the manufacturer or by the service organization.

4 Safety instructions

- ▶ Pay attention to the following safety instructions.



Follow the Operating Instructions BA02165C for the device.

4.1 Workplace safety

As the user, you are responsible for complying with the following safety conditions:

- Installation guidelines
- Local standards and regulations

WARNING

UV radiation from this product

Can cause damage to the eyes and skin!

- ▶ Avoid any exposure of the eyes and skin to the unshielded product.
- ▶ When the sensor is switched on, avoid looking directly into the sensor window without appropriate eye protection. The exposure limits according to IEC 62471:2008 are not exceeded within the first 100 seconds.
- ▶ Appropriate protective goggles must be worn to protect against UV radiation.
- ▶ Cover the light source when performing maintenance tasks that do not need UV light.
- The risk to the observer depends on how the user installs and uses the sensor.
- The sensor's lamp radiates light in the 254 nm wavelength range (UV radiation). The sensor's lamp is categorized as Risk Group 3 according to EN/IEC 62471.

4.2 Operational safety

Before commissioning the entire measuring point:

1. Verify that all connections are correct.
2. Ensure that electrical cables and hose connections are undamaged.
3. Do not operate damaged products, and protect them against unintentional operation.
4. Label damaged products as defective.

During operation:





- ▶ If faults cannot be rectified:
products must be taken out of service and protected against unintentional operation.

4.3 Product safety







The product is designed to meet state-of-the-art safety requirements, has been tested, and left the factory in a condition in which it is safe to operate. The relevant regulations and international standards have been observed.

5 Symbols

5.1 Safety information

Structure of information	Meaning
<p> DANGER</p> <p>Causes (/consequences) If necessary, Consequences of non-compliance (if applicable)</p> <ul style="list-style-type: none"> ▶ Corrective action 	<p>This symbol alerts you to a dangerous situation. Failure to avoid the dangerous situation will result in a fatal or serious injury.</p>
<p> WARNING</p> <p>Causes (/consequences) If necessary, Consequences of non-compliance (if applicable)</p> <ul style="list-style-type: none"> ▶ Corrective action 	<p>This symbol alerts you to a dangerous situation. Failure to avoid the dangerous situation can result in a fatal or serious injury.</p>
<p> CAUTION</p> <p>Causes (/consequences) If necessary, Consequences of non-compliance (if applicable)</p> <ul style="list-style-type: none"> ▶ Corrective action 	<p>This symbol alerts you to a dangerous situation. Failure to avoid this situation can result in minor or more serious injuries.</p>
<p> NOTICE</p> <p>Cause/situation If necessary, Consequences of non-compliance (if applicable)</p> <ul style="list-style-type: none"> ▶ Action/note 	<p>This symbol alerts you to situations which may result in damage to property.</p>

5.2 Symbols used

	Additional information, tips
	Permitted or recommended
	Not permitted or not recommended
	Reference to device documentation
	Reference to page
	Reference to graphic
	Result of a step

6 Scope of delivery

71546713 Kit CFS51 flow assembly scrubber

Item	Description	Quantity	Base unit
a	Assembly PE HD	1	Piece
b	Bearing block	1	Piece
c	Ring clip	1	Piece
d	Double sealing ring, assembly CFS51, PE HD	1	Piece
e	Sensor adapter, titanium 40 mm (1.57 in)	1	Piece
f	Coupling nut, PP	1	Piece
g	Allen screw, M5x40, titanium	1	Piece
h	Allen screw, M8x70, titanium	1	Piece
i	Silicone grease, medium-viscosity 2 g (0.07 oz)	1	Piece
j	Cleaning cloth, isopropyl alcohol	1	Piece
	Service kit instructions	1	Piece



71546714 Kit CFS51 assembly scrubber seal kit

Item	Description	Quantity	Base unit
a	Double sealing ring, assembly CFS51, PE HD	1	Piece
b	O-ring ID 39.34 W 2.62 OD 44.58 FKM	1	Piece
c	O-ring ID 44.12 W 2.62 OD 49.36 FKM	1	Piece
d	Silicone grease, medium-viscosity 2 g (0.07 oz)	1	Piece
	Service kit instructions	1	Piece



71546716 Kit CFS51 titanium sensor adapter

Item	Description	Quantity	Base unit
a	Titanium sensor adapter, 40 mm (1.57 in) sensor	1	Piece
b	Torx screw, M5x16, titanium	1	Piece
c	Cleaning cloth, isopropyl alcohol	1	Piece
	Service kit instructions	1	Piece



71546718 Kit CFS51 coupling nut and ring clip

Item	Description	Quantity	Base unit
a	Coupling nut, PP	1	Piece
b	Ring clip holder	1	Piece
c	Spacer	1	Piece
d	Allen screw, M5x40, titanium	1	Piece
e	Silicone grease, medium-viscosity 2 g (0.07 oz)	1	Piece
f	Cleaning cloth, isopropyl alcohol	1	Piece
	Service kit instructions	1	Piece



71546719 Kit CFS51 2x adapter G1/4-8 mm (0.24 in)OD PVDF

Item	Description	Quantity	Base unit
a	Coupling, elbowed, PVDF	2	Piece
b	Hose adapter G1/4 PVDM /FKM + O-ring	2	Piece
c	Silicone grease, medium-viscosity 2 g (0.07 oz)	1	Piece
	Service kit instructions	1	Piece

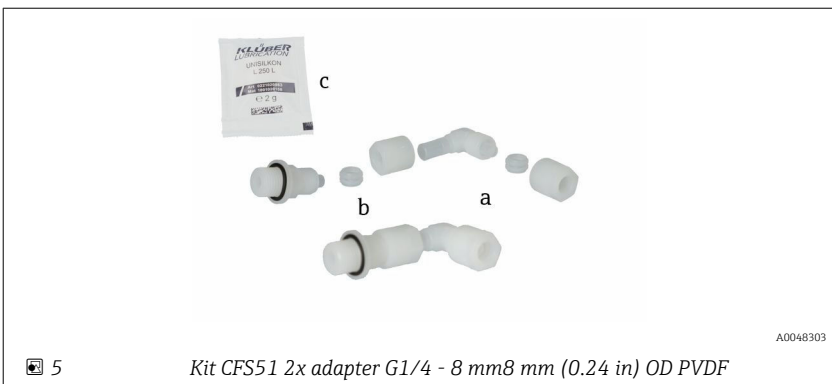

71546721 Kit CFS51 cleaning adapter PVDF

Item	Description	Quantity	Base unit
a	Coupling, elbowed, PVDF	1	Piece
b	Hose adapter G1/4 PVDM /FKM + O-ring	1	Piece
c	Check valve FKM	1	Piece
d	Silicone grease, medium-viscosity 2 g (0.07 oz)	1	Piece
	Service kit instructions	1	Piece

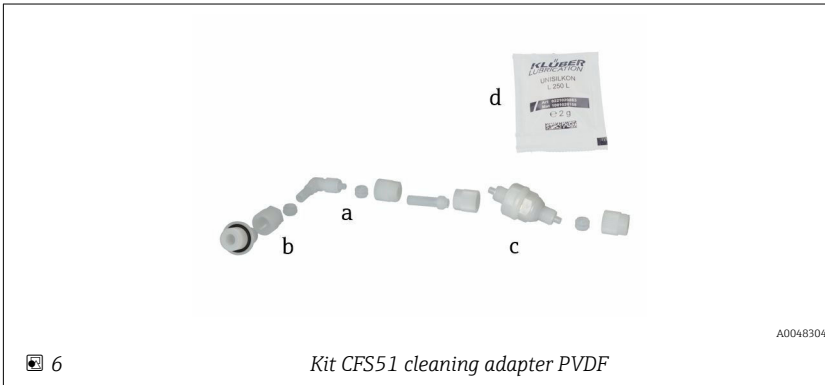

71546722 Kit CFS51 check valve 6 mm (0.24 in) OD PVDF

Item	Description	Quantity	Base unit
a	Check valve	1	Piece
	Service kit instructions	1	Piece

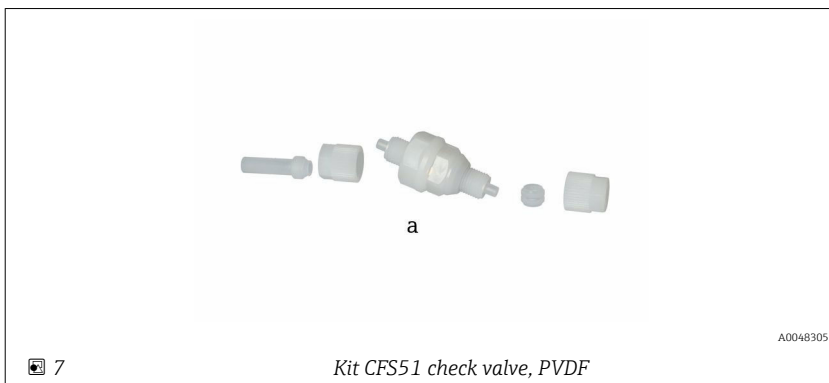

71546723 Kit CFS51 2x hose support DN6/8

Item	Description	Quantity	Base unit
a	Hose support DN6/8	2	Piece
	Service kit instructions	1	Piece

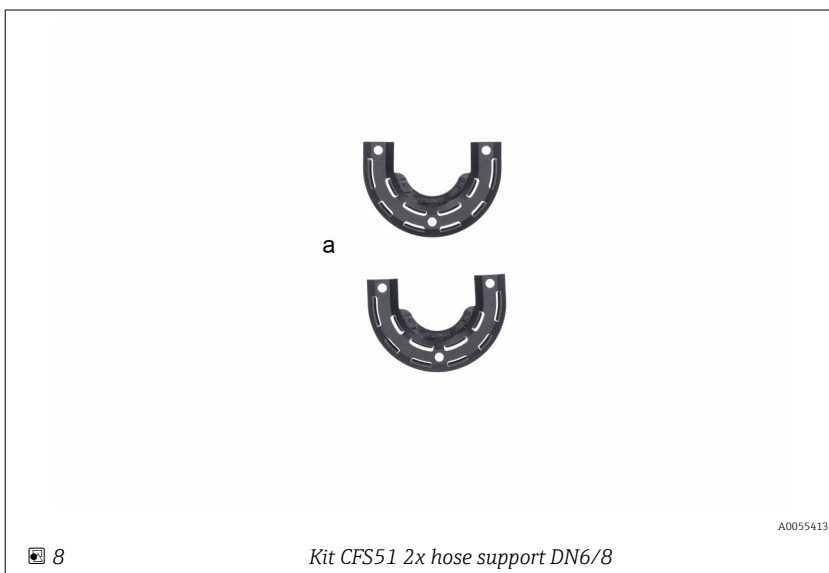

7 Tool list

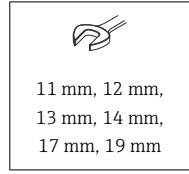
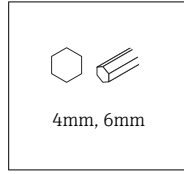
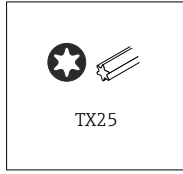
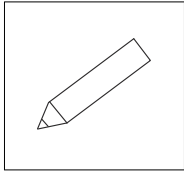
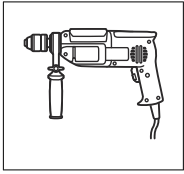

8 Mounting

8.1 Mounting requirements

8.1.1 Dimensions

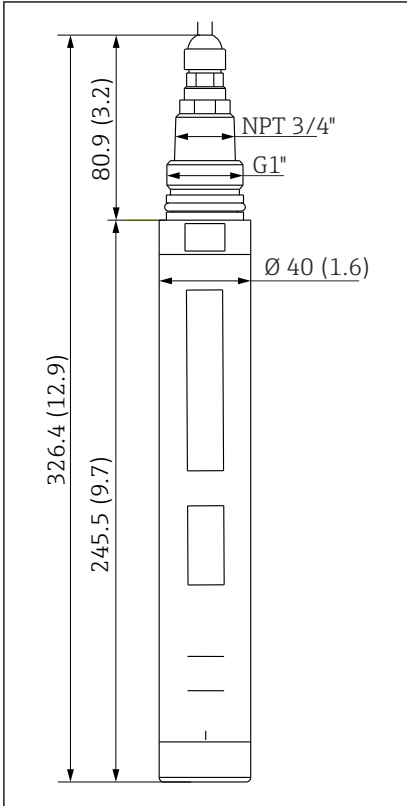

9 Sensor dimensions. Engineering unit: mm (in)

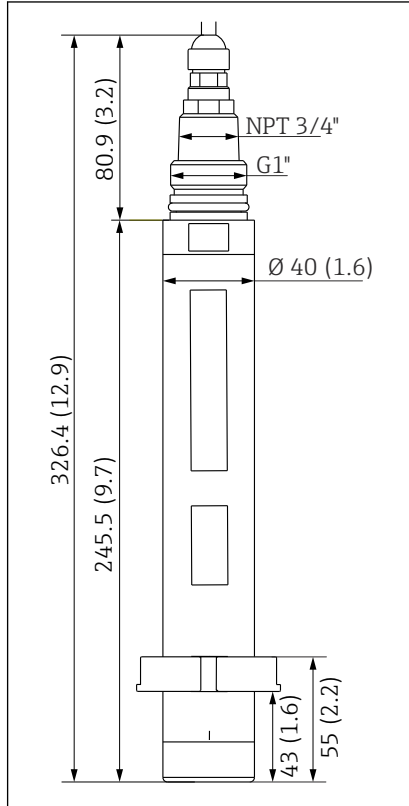

10 Dimensions of sensor with clamping ring. Engineering unit: mm (in)

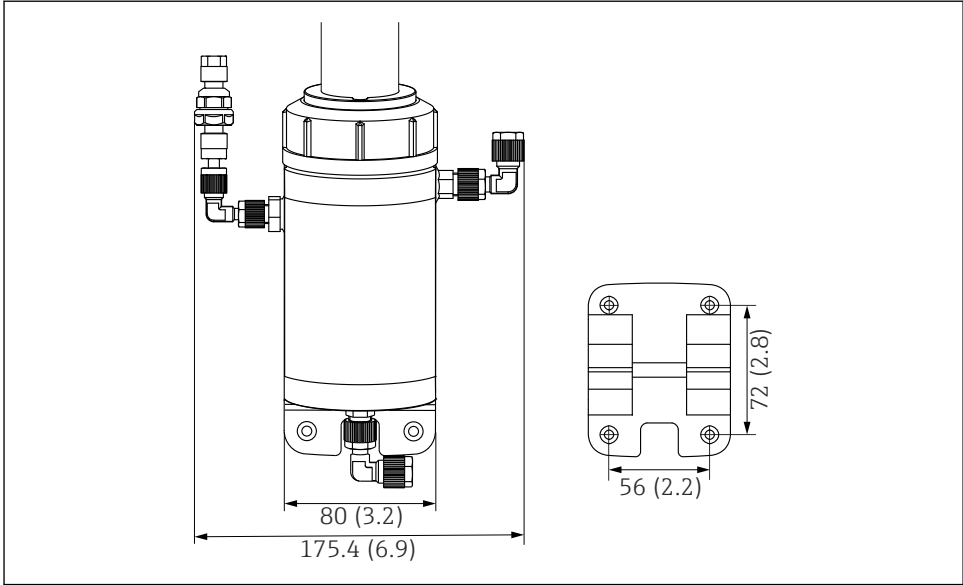

A0046891

11 Dimensions of assembly with securing plate (right). Engineering unit: mm (in)

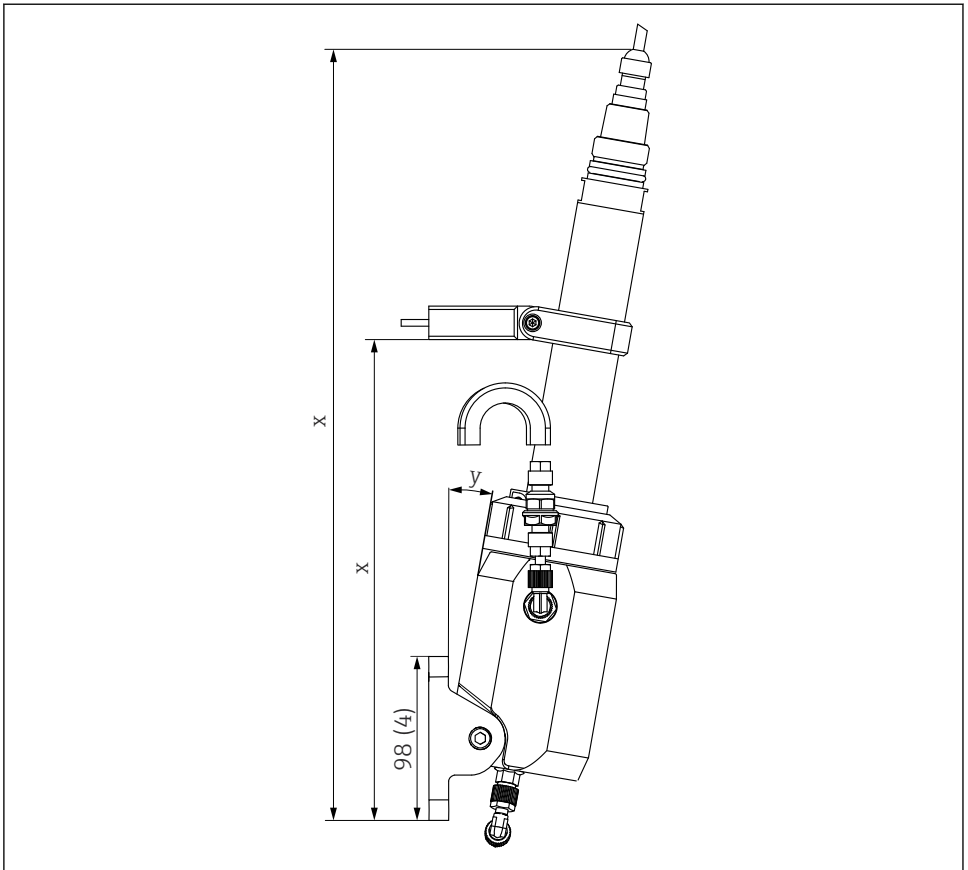

A0046892

12 Dimensions of mounted sensor with assembly. Engineering unit: mm (in)

x Variable length (depending on mounting)

y Variable angle (depending on mounting)

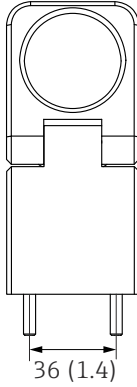

A0047395

✎ 13 Dimensions of ring clip with spacer. Engineering unit: mm (in)

8.1.2 Installation instructions

The angle of inclination of the sensor can affect the formation of air bubbles below the sensor. The greater the angle of inclination of the sensor, the more insensitive the measurement is to air bubbles.



- ▶ Adjust the angle of inclination if many air bubbles form .

8.1.3 Orientation

The angle of inclination of the sensor can affect the formation of air bubbles below the sensor. The greater the angle of inclination of the sensor, the more insensitive the measurement is to air bubbles.

- ▶ Adjust the angle of inclination if many air bubbles form .

Angle of inclination of sensor

The angle of inclination of the sensor can be adjusted depending on the measuring point. The angle of inclination is determined by the position of the spacer on the panel →  12,  15.

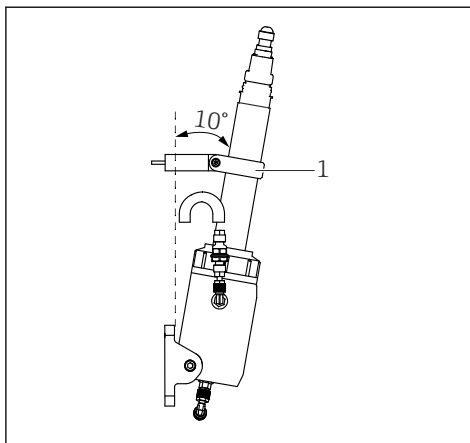

A0046899

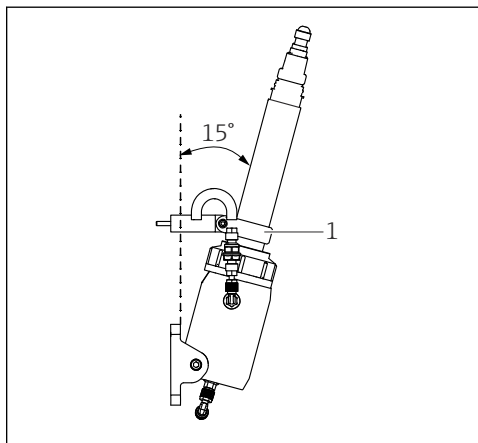

A0046900

 14 Example of spacer installed at top, 10° angle to panel

 15 Example of spacer installed at bottom, 15° angle to panel

1 Ring clip with spacer

1 Ring clip with spacer

8.1.4 Installing the assembly with sensor

 The mounting materials for securing the bearing block on the wall are not included in the scope of supply and must be supplied by the customer. The holes of the bearing block are suitable for 5 mm (0.2 in) screws.

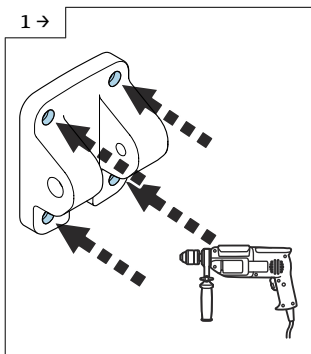

A0050156

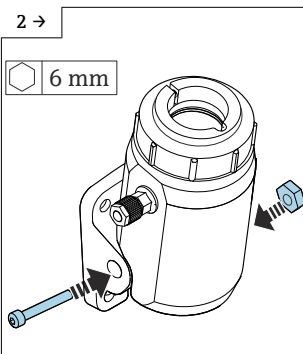

A0055414

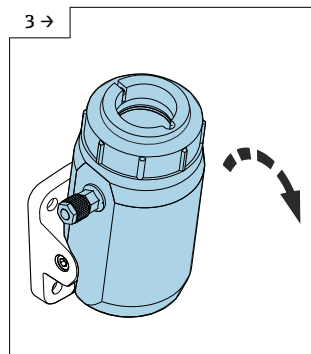

A0055415

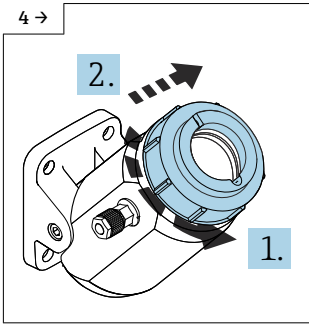

A0055416

- ▶ Before use, grease the O-rings with the silicone grease provided.

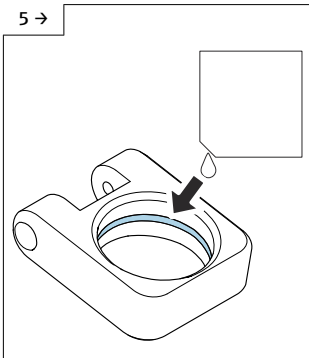

A0048562

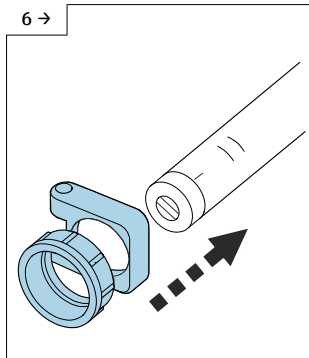

A0049334

- ▶ Using the cleaning cloth supplied, thoroughly degrease the sensor and the marking for fastening the clamping ring.

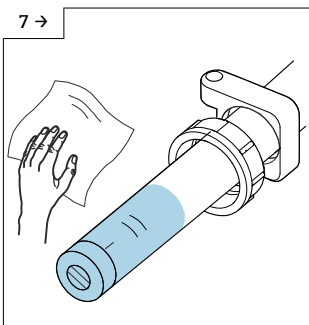

A0049337

Alignment of the clamping ring on the sensor

1. Align the joint of the clamping ring vertically to the optical window of the sensor.

2. Slide the clamping ring exactly as far as the horizontal alignment line, using the installation marking as an aid.

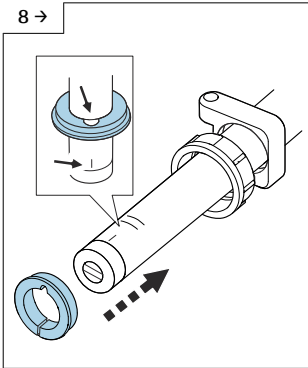

A0049331

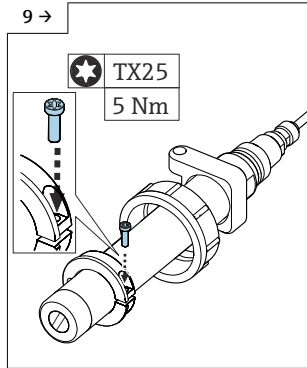

A0049332

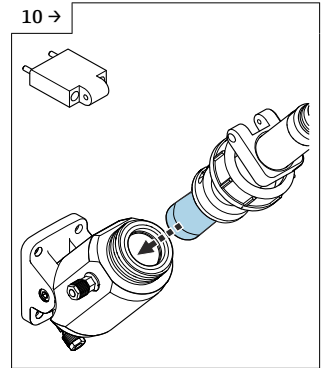

A0055441

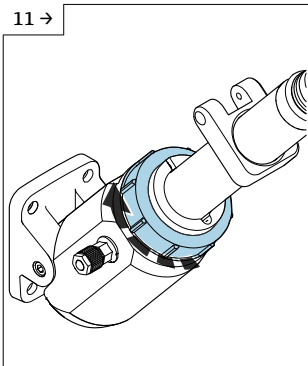

A0055418

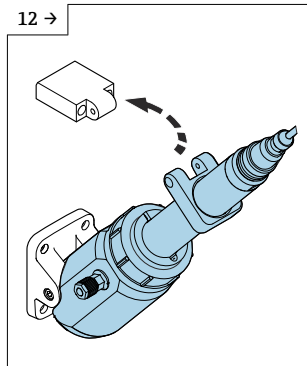

A0055419

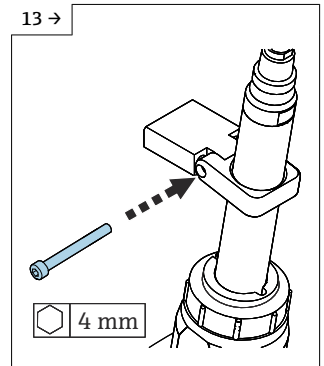

A0048579

i An angle of 15° is recommended. By orienting the sensor at this angle, air bubbles can escape more easily.

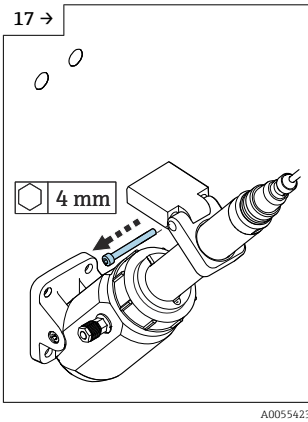
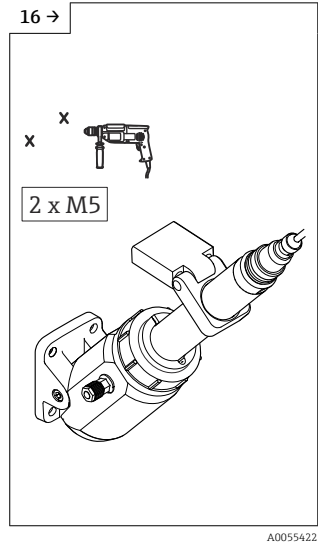
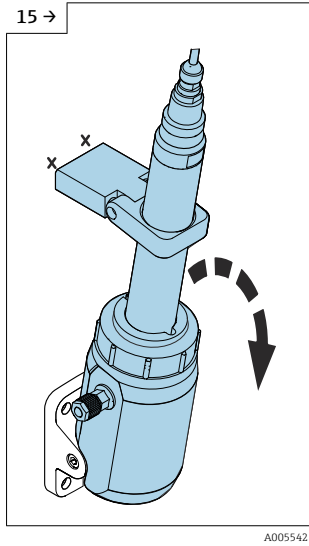
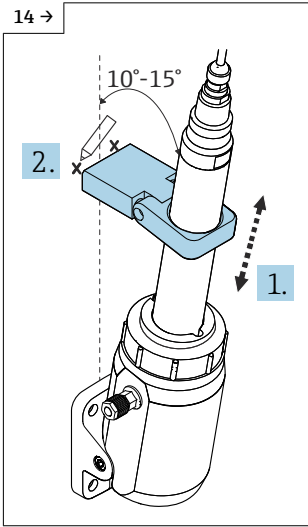

i The mounting materials used to secure the ring clip holder on the wall are not included in the scope of delivery and must be supplied by the customer. The holes of the ring clip holder are suitable for 5 mm (0.2 in) screws.

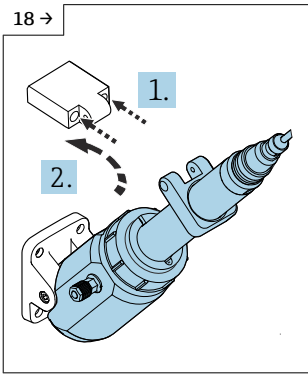

A0055424

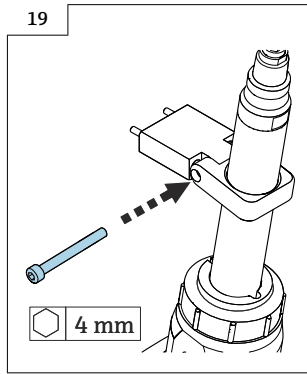

A0050153

8.2 Mounting the adapters

► Before use, grease the O-rings with the silicone grease provided.

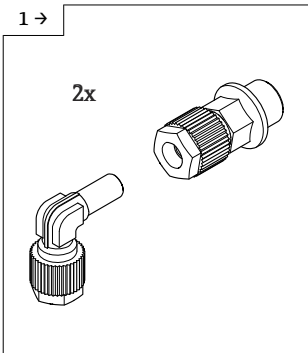

A0048248

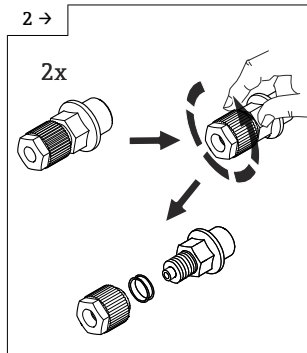

A0048249

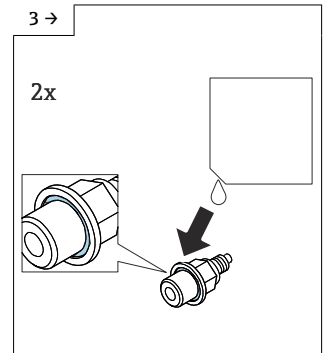

A0048567

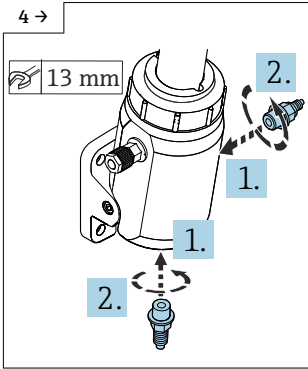

1. Insert the pipe into the coupling as far as it will go.
2. Screw on the union nuts by hand until you feel resistance.
3. Use an open-ended wrench to tighten the union nuts by 1 3/4 turns.

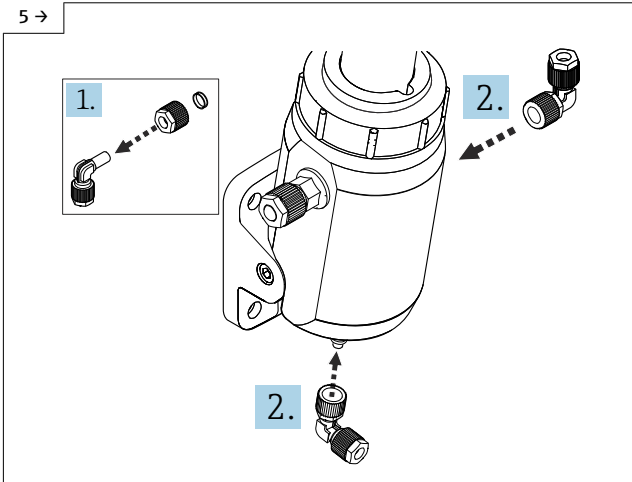

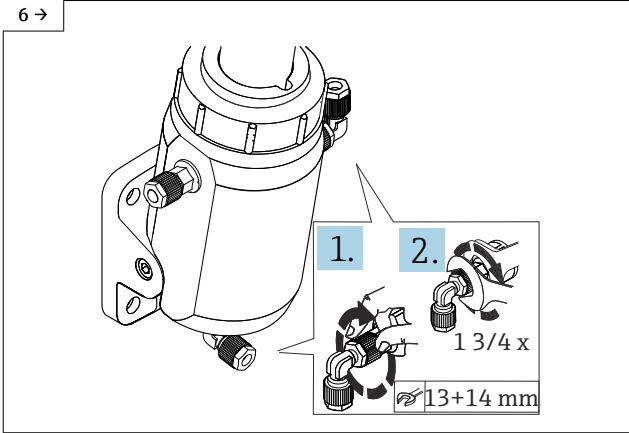

A0055427

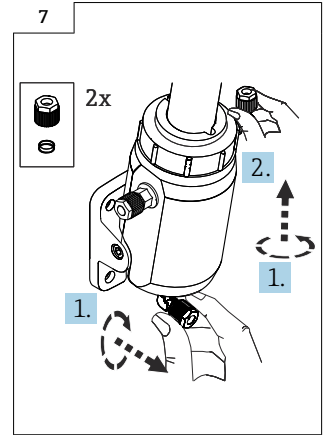

A0055428

i The hoses are not included in the scope of delivery.

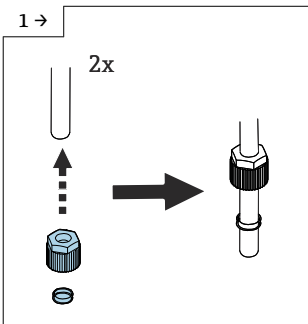

A0048274

1. Insert the hoses into the coupling as far as they will go.
2. Screw on the union nuts by hand until you feel resistance.

- Use an open-ended wrench to tighten the union nuts by $1 \frac{3}{4}$ turns.

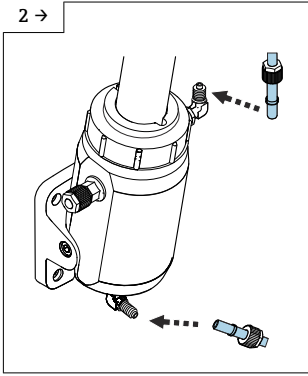

A0055429

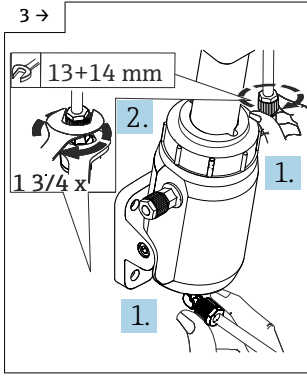

A0055430

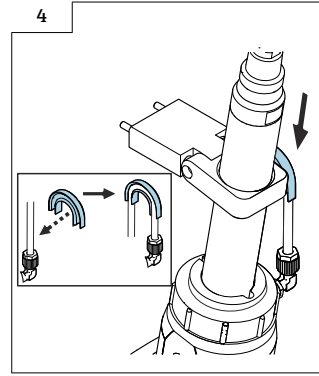

A0048277

8.3 Mounting the cleaning adapter

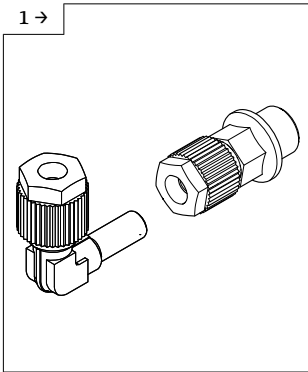

A0048366

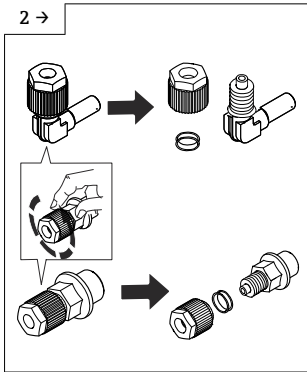

A0048258

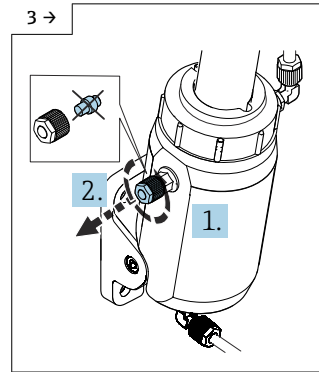

A0055448

- Insert the pipe into the coupling as far as it will go.
- Screw on the union nut by hand until you feel resistance.

3. Use an open-ended wrench to tighten the union nut by $1\frac{3}{4}$ turns.

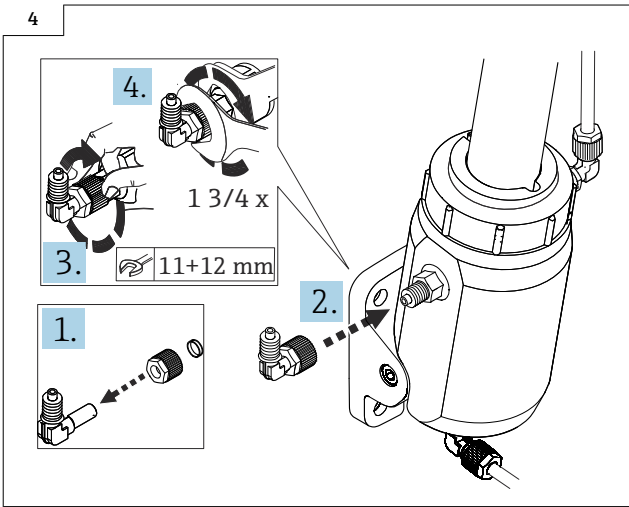

8.4 Mounting the check valve

- Before use, grease the O-rings with the silicone grease provided.

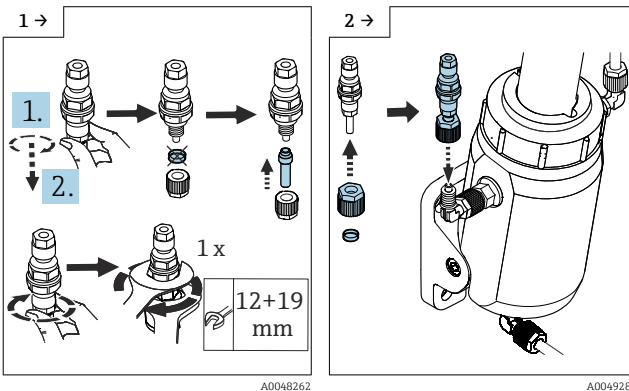

1. Insert the pipe into the coupling as far as it will go.
2. Screw on the union nut by hand until you feel resistance.

3. Use an open-ended wrench to tighten the union nut by 1 3/4 turns.

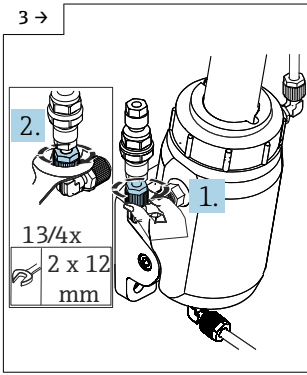

A0049340

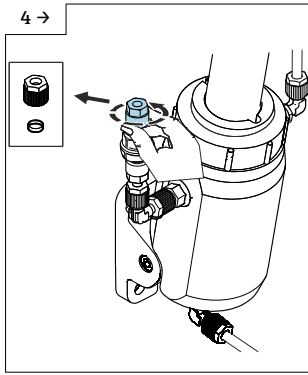

A0049285

- i** The hoses are not included in the scope of delivery.

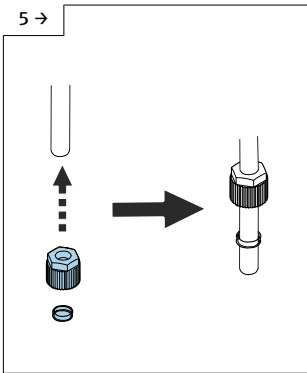

A0048266

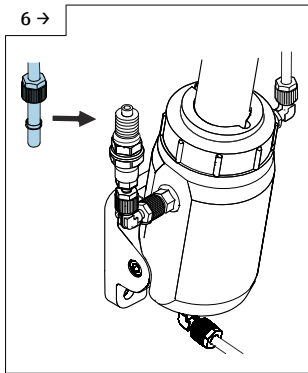



A0049287

1. Insert the hose into the coupling as far as it will go.
2. Screw on the union nut by hand until you feel resistance.

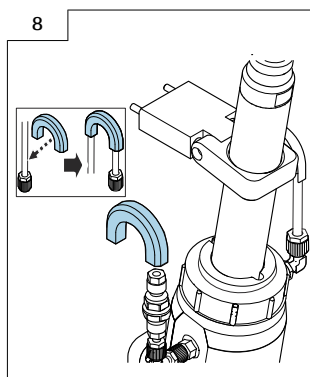
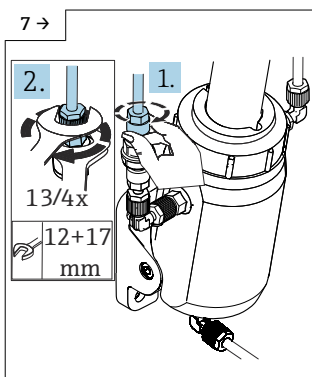
3. Use an open-ended wrench to tighten the union nut by 1 3/4 turns.



 For detailed information on the electrical connection, see the "Electrical connection" section of the Operating Instructions for the device.

 For detailed information on commissioning, see the "Commissioning" section of the Operating Instructions for the device.

8.5 Post-mounting check

Put the sensor into operation only if the following questions can be answered with "yes":

- Are the sensor and cable undamaged?
- Is the orientation correct?
- Is the sensor installed in the assembly and not suspended from the cable?

9 Replacing the spare part kits

9.1 Preparation

CAUTION

Process medium and medium residues

Risk of injury from high pressure, high temperatures or chemical hazards!

- ▶ Wear protective gloves, protective goggles and protective clothing.
- ▶ Mount or dismantle the assembly only in vessels or pipes that are empty and unpressurized.

9.1.1 Removing hoses from assembly

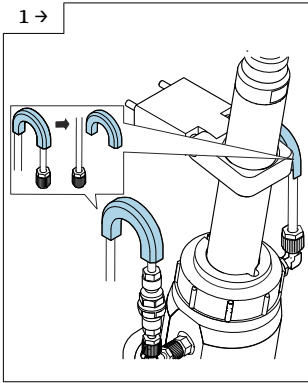

A0048286

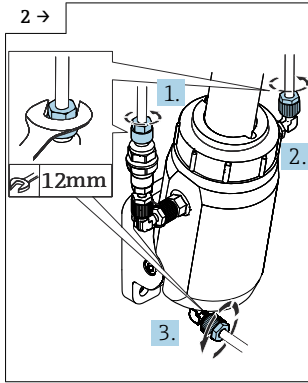

A0049295

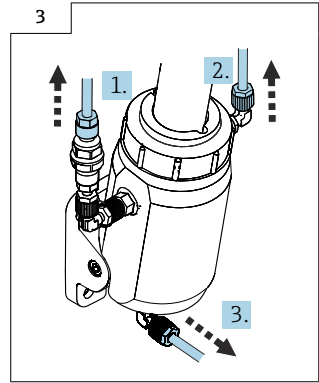

A0049292

9.1.2 Putting the assembly and sensor into the service position

- Secure the screw so that it doesn't fall off.

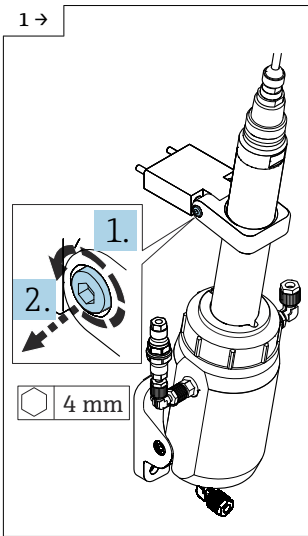

A0049299

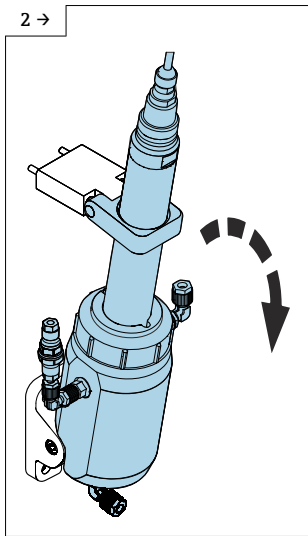

A0049298

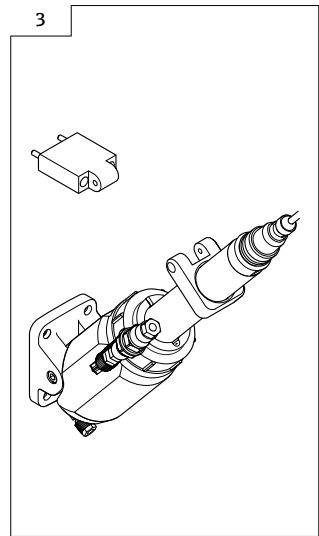

A0049297

9.2 Replacing the check valve

- ▶ Carry out preparations for check valve in accordance with Section 9.1.1. →  28

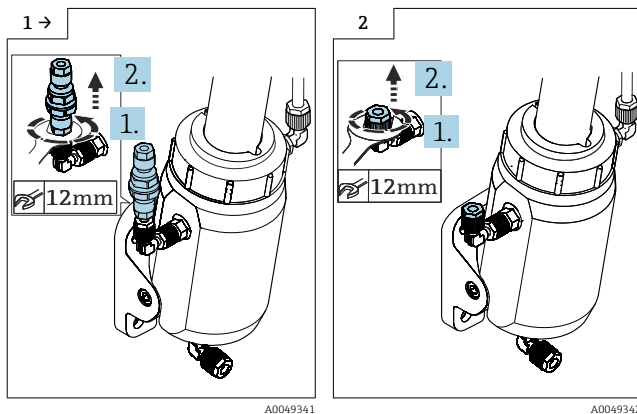

- ▶ Replace the used check valve with the new spare part.
- ▶ Install the new spare part in accordance with Section 8.4. →  25

Pre-mounted couplings or repeat installation of adapters

1. Screw on the union nut by hand until you feel resistance.
2. Tighten the union nuts with one turn of the wrench for final installation.

9.3 Replacing the cleaning adapter

- ▶ Carry out preparations for check valve in accordance with Section 9.1.1. →  28
- ▶ Before use, grease the O-rings with the silicone grease provided.

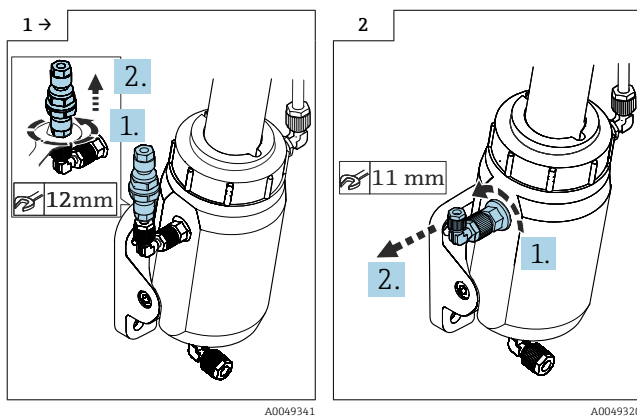

- ▶ Replace the used cleaning adapter with the new spare part.
- ▶ Install the new spare part in accordance with Sections 8.3 and 8.4. → 📖 24 → 📖 25

Pre-mounted couplings or repeat installation of adapters

1. Screw on the union nut by hand until you feel resistance.
2. Tighten the union nuts with one turn of the wrench for final installation.

9.4 Replacing the adapters

- ▶ Carry out preparations in accordance with Section 9.1.1. → 📖 28
- ▶ Before use, grease the O-rings with the silicone grease provided.

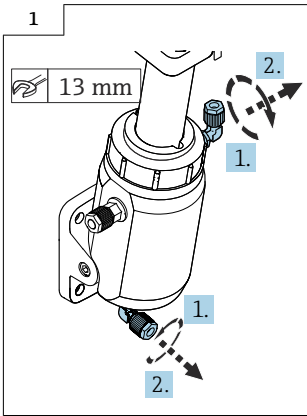

A0055451

- ▶ Replace the used adapters with new spare parts.
- ▶ Install the new spare parts in accordance with Section 8.2. → 📖 21

Pre-mounted couplings or repeat installation of adapters

1. Screw on the union nuts by hand until you feel resistance.
2. Tighten the union nuts with one turn of the wrench for final installation.

9.5 Replacing the titanium sensor adapter

- Carry out preparations in accordance with Section 9.1. →  27

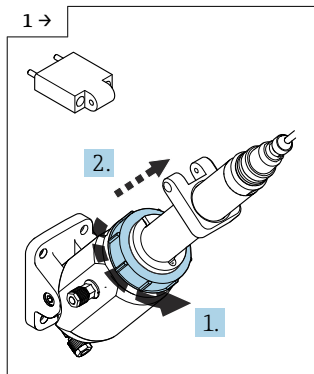

A0055439

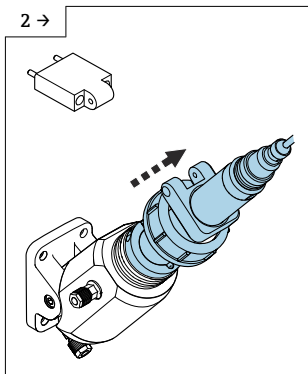

A0055440

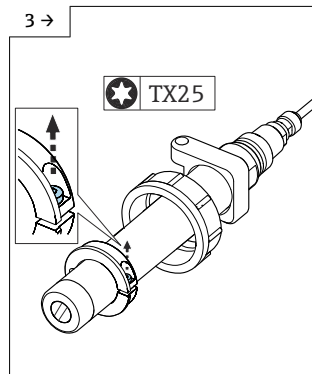

A0049335

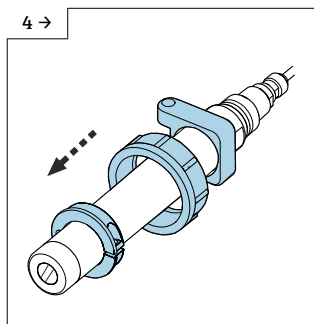

A0049336

1. Replace the used titanium clamping ring with the new spare part.
2. Using the cleaning cloth supplied, thoroughly degrease the sensor and the marking for fastening the clamping ring.

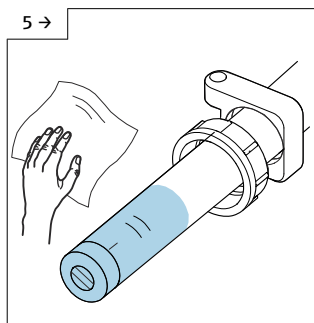

A0049337

Alignment of the clamping ring on the sensor

1. Align the joint of the clamping ring vertically to the optical window of the sensor.
2. Slide the clamping ring exactly as far as the horizontal alignment line, using the installation marking as an aid.

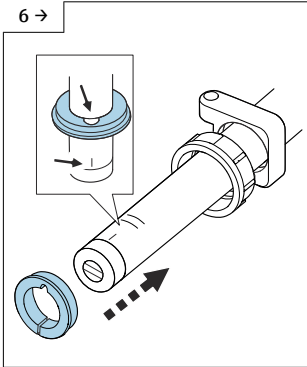

A0049331

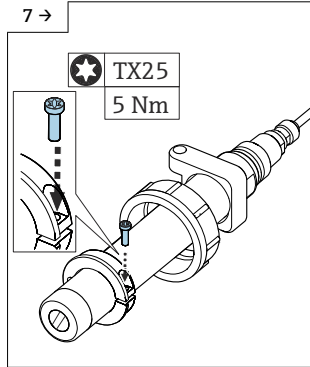

A0049332

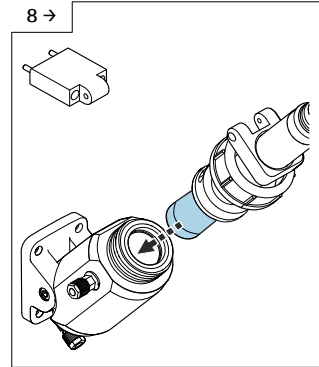

A0055441

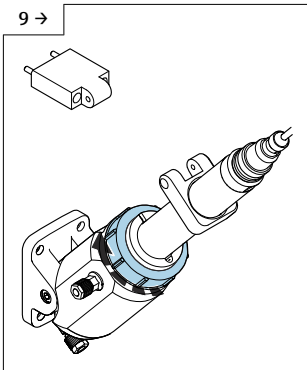

A0055442

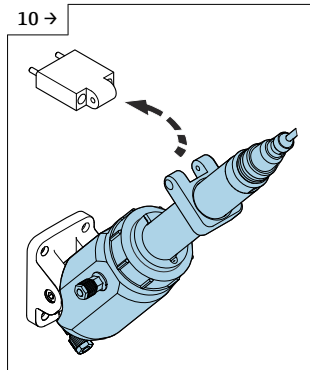

A0055443

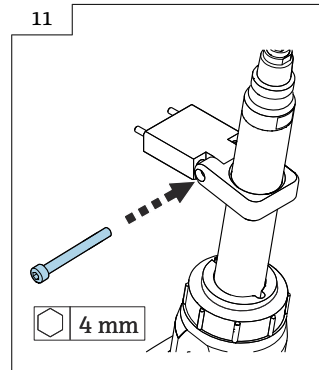

A0050153

9.6 Replacing the coupling nut and ring clip

- ▶ Carry out preparations in accordance with Section 9.1. →  27

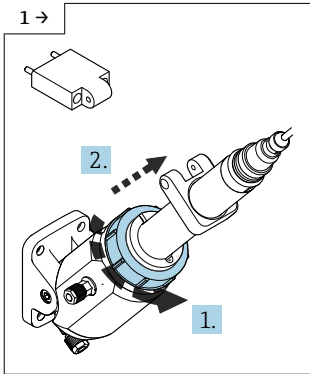

A0055439

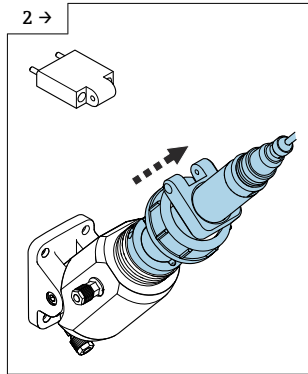

A0055440

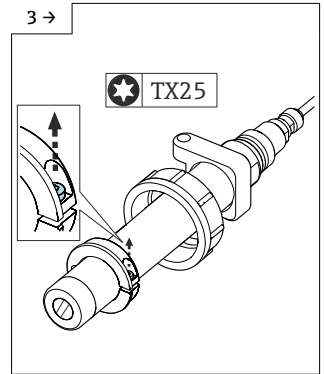

A0049335

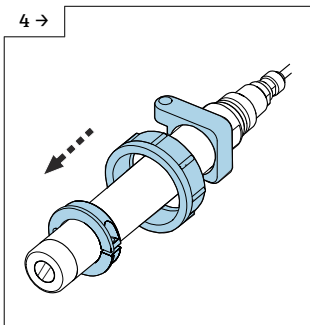

A0049336

- ▶ Replace the used coupling nut and ring clip with new spare parts.
- ▶ Before use, grease the O-rings with the silicone grease provided.

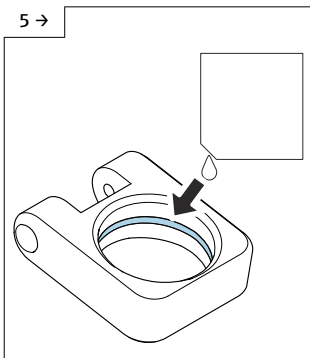

A0048562

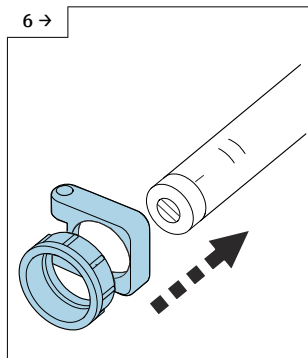

A0049334

- ▶ Using the cleaning cloth supplied, thoroughly degrease the sensor and the marking for fastening the clamping ring.

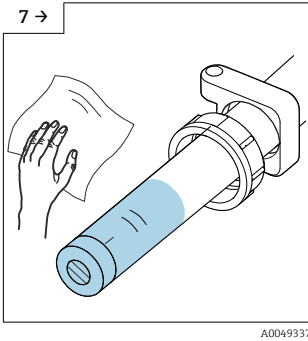

Alignment of the clamping ring on the sensor

1. Align the joint of the clamping ring vertically to the optical window of the sensor.
2. Slide the clamping ring exactly as far as the horizontal alignment line, using the installation marking as an aid.

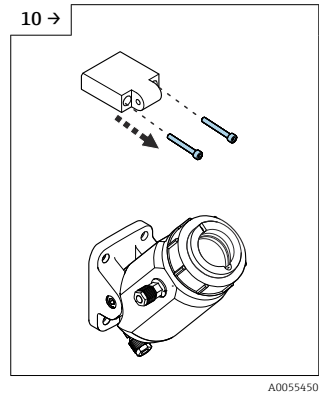
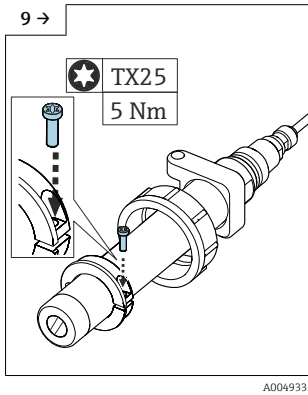
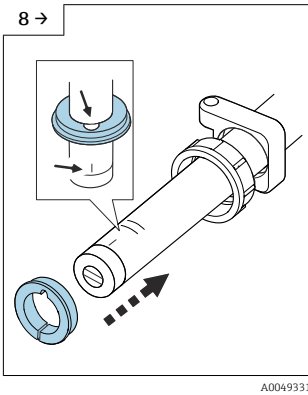

- Replace the used spacer with the new spare part.

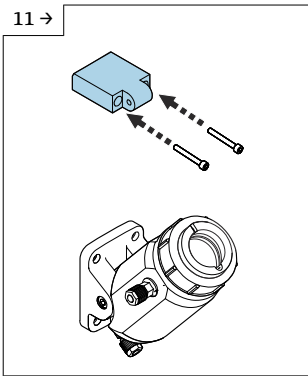

A0055449

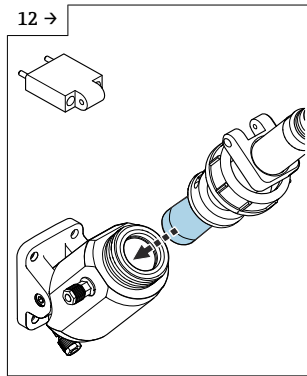

A0055441

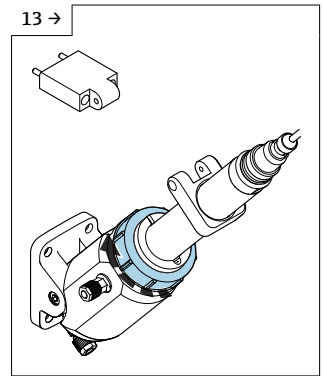

A0055442

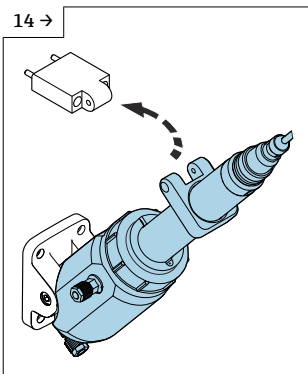

A0055443

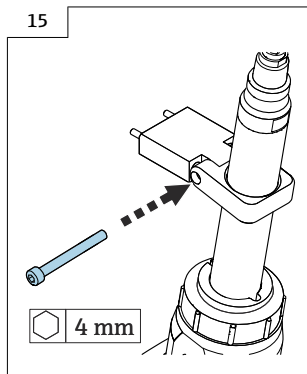

A0050153

9.7 Replacing the seals

- Carry out preparations in accordance with Section 9.1.1. →  28

► Replace the used seals with new seals.

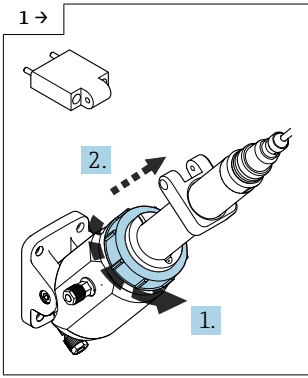

A0055439

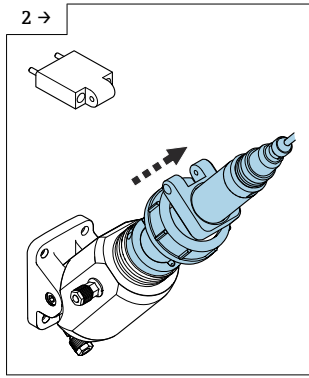

A0055440

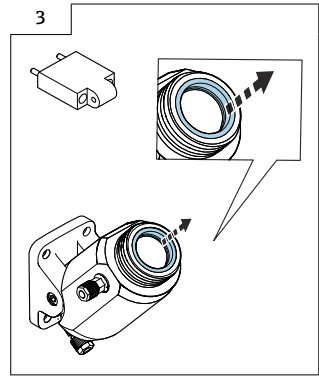

A0055446

1. Replace the used seals with new seals.

2. Before use, grease the new O-rings with the silicone grease provided.

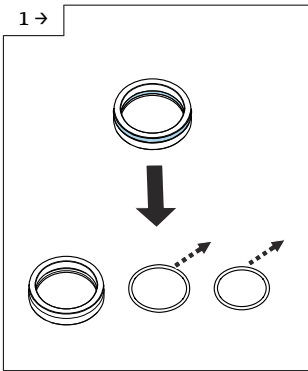

A0048310

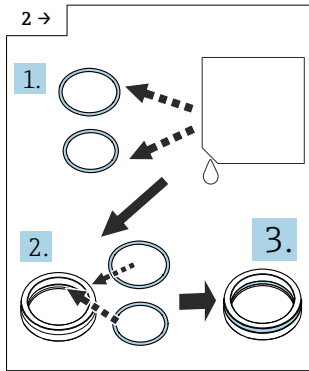

A0048575

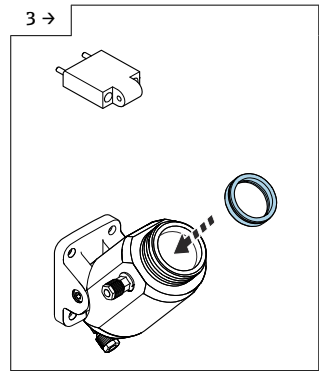

A0055447

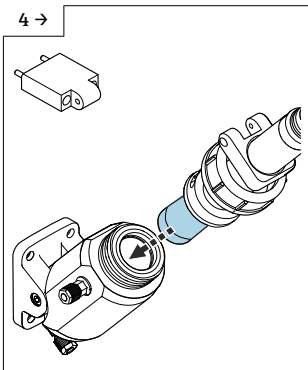

A0055441

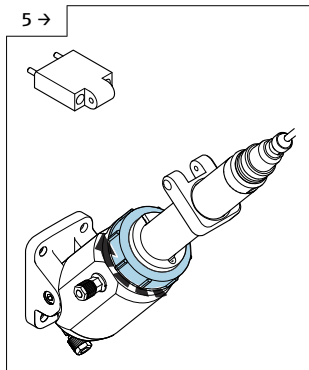

A0055442

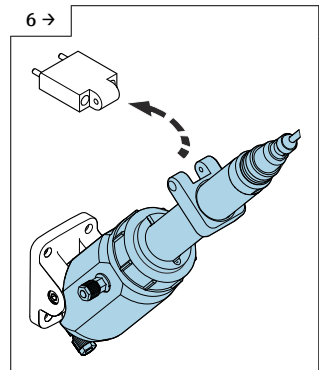

A0055443

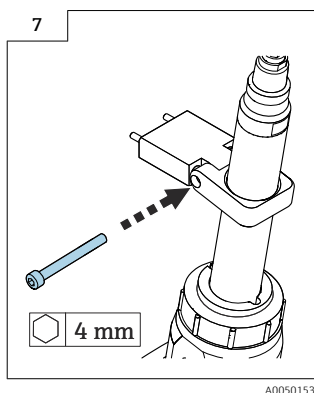

- ▶ Install the adapter and hoses in accordance with Section 8.2. → 21

Pre-mounted couplings or repeat installation of adapters

1. Screw on the union nut by hand until you feel resistance.
2. Tighten the union nut with one turn of the wrench for final installation.

10 Disposal

- ▶ Observe the local regulations.



If required by the Directive 2012/19/EU on waste electrical and electronic equipment (WEEE), the product is marked with the depicted symbol in order to minimize the disposal of WEEE as unsorted municipal waste. Do not dispose of products bearing this marking as unsorted municipal waste. Instead, return them to the manufacturer for disposal under the applicable conditions.



71654399

www.addresses.endress.com
