

Safety Instructions

Cerabar M PMP51, PMP55

4-20 mA HART, PROFIBUS PA,
FOUNDATION Fieldbus

Ex db IIC T6/T4 Gb



Cerabar M PMP51, PMP55

4-20 mA HART, PROFIBUS PA, FOUNDATION Fieldbus

Table of contents

About this document	4
Associated documentation	4
Supplementary documentation	4
Certificates and declarations	4
Manufacturer address	4
Extended order code	4
Safety instructions: General	6
Safety instructions: Specific conditions of use	7
Safety instructions: Installation	7
Safety instructions: Ex d joints	8
Temperature tables	8
Connection data	8

About this document

This document has been translated into several languages. Legally determined is solely the English source text.

Associated documentation

To commission the device, please observe the Operating Instructions pertaining to the device:

HART
BA00382P

PROFIBUS PA
BA00383P

FOUNDATION Fieldbus
BA00384P

Supplementary documentation

Explosion protection brochure: CP00021Z

The Explosion-protection brochure is available:

- In the download area of the Endress+Hauser website:
www.endress.com -> Downloads -> Brochures and Catalogs -> Text Search: CP00021Z
- On the CD for devices with CD-based documentation

Certificates and declarations**NEPSI Declaration of Conformity**

Certificate number:
GYJ24.1061X

Affixing the certificate number certifies conformity with the following standards (depending on the device version):

- GB/T 3836.1-2021
- GB/T 3836.2-2021

Manufacturer address

Endress+Hauser SE+Co. KG
Hauptstraße 1
79689 Maulburg, Germany

Address of the manufacturing plant: See nameplate.

Extended order code

The extended order code is indicated on the nameplate, which is affixed to the device in such a way that it is clearly visible. Additional information about the nameplate is provided in the associated Operating Instructions.

Basic specifications

Position 1, 2 (Approval)		
Selected option		Description
PMP5x	NB	NEPSI Ex db IIC T6/T4 Gb

Position 3 (Output)		
Selected option		Description
PMP5x	2	4-20 mA HART
	3	PROFIBUS PA
	4	FOUNDATION Fieldbus

Optional specifications

No options specific to hazardous locations are available.

Safety instructions:
General

- Comply with the installation and safety instructions in the Operating Instructions.
- Staff must meet the following conditions for mounting, electrical installation, commissioning and maintenance of the device:
 - Be suitably qualified for their role and the tasks they perform
 - Be trained in explosion protection
 - Be familiar with national regulations
- For installation, use and maintenance of the device, users must also observe the requirements stated in the Operating Instructions and the standards:
 - GB 50257-2014: "Code for construction and acceptance of electric device for explosion atmospheres and fire hazard electrical equipment installation engineering".
 - GB/T 3836.13-2021: "Explosive atmospheres, Part 13: Equipment repair, overhaul, reclamation and modification".
 - GB/T 3836.15-2017: "Explosive atmospheres, Part 15: Electrical installations design, selection and erection".
 - GB/T 3836.16-2022: "Explosive atmospheres, Part 16: Electrical installations inspection and maintenance".
- Install the device according to the manufacturer's instructions and national regulations.

- Only use the device in media to which the wetted materials have sufficient durability.
- Avoid electrostatic charging:
 - Of plastic surfaces (e.g. enclosure, sensor element, special varnishing, attached additional plates, ...)
 - Of isolated capacities (e.g. isolated metallic plates)
- Alterations to the device can affect the explosion protection and must be carried out by staff authorized to perform such work by Endress+Hauser.

Safety instructions:
Specific conditions of use

- For light metal flanges or flange faces (e.g. titanium, zirconium), avoid sparks caused by impact and friction.
- To avoid electrostatic charging: Do not rub surfaces with a dry cloth.
- In the event of additional or alternative special varnishing on the enclosure or other metal parts or for adhesive plates:
 - Observe the danger of electrostatic charging and discharge.
 - Do not install in the vicinity of processes (≤ 0.5 m) generating strong electrostatic charges.

Safety instructions:
Installation

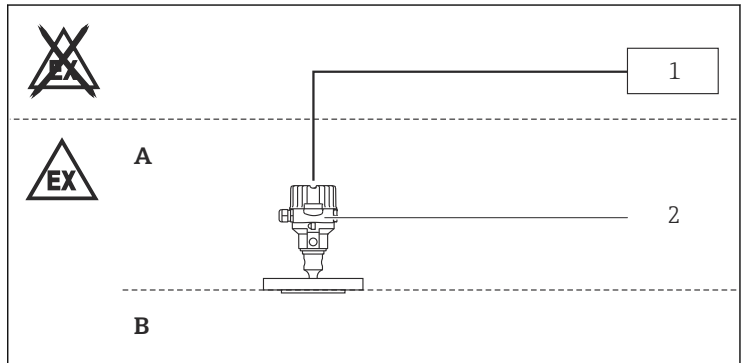

- A Zone 1, Electronic
 B Zone 1, Process
 1 Power supply U
 2 PMP51, PMP55

- In potentially explosive atmospheres: Do not open the connection compartment cover and the electronics compartment cover when energized.
- Before operation:
 - Screw in the cover all the way.
 - Tighten the securing clamp on the cover.
- Connect the device:
 - Using suitable cable and wire entries of protection type "Flameproof Enclosure (Ex db)".
 - Using piping systems of protection type "Flameproof Enclosure (Ex db)".
- When connecting through a conduit entry approved for this purpose, mount the associated sealing unit directly at the enclosure.
- For ambient temperatures higher than +70 °C, use suitable heat resisting cables or wires.
- Seal unused entry glands with supplied metal blind plug. Alternative use only suitable, separate approved Ex db blanking elements.
- The plastic sealing plug is used only as transport protection.

Safety instructions: Ex d joints

- If required or if in doubt: ask manufacturer for specifications.
- Flameproof joints are not intended to be repaired.

Temperature tables

Temperature class	Process temperature T _p (process)	Ambient temperature T _a (ambient): enclosure
T6	≤ 80 °C	-40 °C ≤ T _a ≤ +75 °C
T4	≤ 120 °C	

 Do not exceed the max. ambient temperature at the enclosure.

Device type PMP51

The process temperatures refer to the temperature at the separation membrane.

Device type PMP55

Higher temperatures are permitted depending on the type of diaphragm seal.

Connection data

Basic specification, Position 3 = 2

Power supply
U ≤ 45 V _{DC} P ≤ 1.1 W

Basic specification, Position 3 = 3, 4

Power supply
$U \leq 32 \text{ V}_{\text{DC}}$ $P \leq 1.25 \text{ W}$



71640599

www.addresses.endress.com
