

Technical Information

Deltabar FMD71, FMD72

Level measurement with electronic differential pressure
HART



Electronic differential pressure transmitter with ceramic and metallic measuring cells

Field of application

The device is used to measure the level, volume or mass of liquids in pressurized and vacuum vessels.

Your benefits

The electronic differential pressure system eliminates traditional mechanical issues resulting in greater process availability and reliability

- Safety risks are minimized with the electronic differential pressure system architecture and design
- Lowest total cost of ownership due to reduced installation time, maintenance, downtime and spare requirements, downtime and spare requirements.
- Multivariable level measurement: HART-based differential pressure, head pressure and sensor temperatures from one system
- Continuous health indication of the entire system via HART-based diagnostic
- High reproducibility and long-term stability
- Overload-resistant and function-monitored

Table of contents

About this document	4	Warm-up time	20
Document function	4	Performance characteristics of metallic process membrane	21
Symbols	4	Reference operating conditions	21
Documentation	5	Influence of the installation position depending on sensor	21
List of abbreviations	6	Resolution	21
Turn down calculation	6	Vibration effects	21
Registered trademarks	6	Application limits	21
Function and system design	7	Reference accuracy	22
Measuring principle - electronic differential pressure measurement	7	Thermal change of the zero output and the output span	22
Measuring system	8	Total performance	23
Device features	8	Long-term stability	23
Product design	9	Total error	23
System integration	9	Warm-up time	23
Input	10	Installation	24
Measured variable	10	Mounting location	24
FMD71: measuring range of individual sensors	10	Orientation	24
FMD72: measuring range of individual sensors	11	General installation instructions	24
Output	12	Thermal insulation - FMD71 high-temperature version	24
Output signal	12	Installing the sensor modules	25
Signal range 4 to 20 mA	12	Mounting sensor modules with PVDF installation coupling	25
Signal on alarm 4 to 20 mA	12	Installing the transmitter	25
Maximum load	12	Sensor and transmitter cable	26
Dead time, time constant	13	Environment	27
Dynamic behavior, current output	13	Ambient temperature range	27
Dynamic behavior, HART	13	Storage temperature range	27
Damping	13	Climate class	27
Alarm current	13	Degree of protection	27
Firmware version	13	Vibration resistance	27
Wireless HART data	13	Electromagnetic compatibility	27
Protocol-specific data	14	Process	28
Energy supply	15	Process temperature range for devices with ceramic process membrane FMD71	28
Terminals	15	Process temperature range for devices with metallic process membrane FMD72	28
Terminal assignment	15	Pressure specifications	29
Supply voltage	15	Mechanical construction	30
Cable entries	16	Device height	30
Cable specification for transmitter connection	16	T14 transmitter housing (optional display on the side)	31
Residual ripple	16	T17 transmitter housing (optional display on the side)	31
Influence of power supply	16	Sensor housing	32
Overvoltage protection	16	Selecting the electrical connection	32
Performance characteristics of the ceramic process membrane	17	Explanation of terms	32
Reference operating conditions	17	Process connections FMD71, internal process membrane	33
Influence of the installation position depending on sensor	17	Process connections FMD71, internal process membrane	34
Resolution	17	Process connections FMD71, internal process membrane	35
Vibration effects	17	Process connections FMD71, flush process membrane	36
Application limits	17	Process connections FMD71, flush process membrane	37
Reference accuracy	18	Process connections FMD71, flush process membrane	38
Thermal change in the zero output and the output span	18	FMD71 hygiene	39
Total performance	19	Process connections FMD71, flush process membrane	43
Long-term stability	20		
Total error	20		

Process connections FMD71, flush process membrane	44
Process connections FMD71, flush process membrane	45
Process connections FMD72, internal process membrane . .	46
Process connections FMD72, internal process membrane . .	47
Process connections FMD72, flush process membrane	48
Process connections FMD72, flush process membrane	49
Process connections FMD72, flush process membrane	50
Process connections FMD72, flush process membrane	51
FMD72 hygiene	52
Wall and pipe mounting with mounting bracket	55
Materials in contact with process	56
Materials not in contact with process	57
Operability	61
Operation concept	61
Local operation	61
Operating languages	63
Certificates and approvals	64
CE approval	64
RoHS	64
RCM marking	64
Ex approvals	64
Suitable for hygiene applications	64
Pressure Equipment Directive 2014/68/EU (PED)	64
CRN approval	65
Classification of process sealing between electrical systems and (flammable or combustible) process fluids in accordance with ANSI/ISA 12.27.01	65
Inspection certificates	65
Ordering information	66
Scope of delivery	66
Measuring point (TAG)	66
Documentation	67
Field of Activities	67
Technical Information	67
Operating Instructions	67
Brief Operating Instructions	67
Safety Instructions (XA)	67
Accessories	68
Service-specific accessories	68
Registered trademarks	68
HART®	68

About this document

Document function

The document contains all the technical data on the device and provides an overview of the accessories and other products that can be ordered for the device.

Symbols

Safety symbols



This symbol alerts you to a dangerous situation. Failure to avoid this situation will result in serious or fatal injury.



This symbol alerts you to a dangerous situation. Failure to avoid this situation can result in serious or fatal injury.



This symbol alerts you to a dangerous situation. Failure to avoid this situation can result in minor or medium injury.



This symbol contains information on procedures and other facts which do not result in personal injury.

Electrical symbols



Direct current



Alternating current



Direct current and alternating current



Ground connection

Grounded clamp, which is grounded via a grounding system.



Protective earth (PE)

Ground terminals, which must be grounded prior to establishing any other connections. The ground terminals are located on the inside and outside of the device.

Symbols for certain types of information



Permitted

Procedures, processes or actions that are permitted



Preferred

Procedures, processes or actions that are preferred



Forbidden

Procedures, processes or actions that are forbidden



Tip

Indicates additional information



Reference to documentation



Reference to page



Reference to graphic



Visual inspection

Symbols in graphics

1, 2, 3, ...

Item numbers

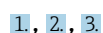

Series of steps

A, B, C, ...
Views

A-A, B-B, C-C etc.
Sections

Documentation



The document types listed are available:

In the Download Area of the Endress+Hauser website: www.endress.com → Download

Brief Operating Instructions (KA): getting the 1st measured value quickly

KA01105P:

The Brief Operating Instructions contain all the essential information from incoming acceptance to initial commissioning.

Operating Instructions (BA): your comprehensive reference

BA01044P:

The Operating Instructions contain all the information that is required in various phases of the life cycle of the device: from product identification, incoming acceptance and storage, to mounting, connection, operation and commissioning through to troubleshooting, maintenance and disposal.

Description of Device Parameters (GP): reference for your parameters

GP01013P:

The document provides a detailed explanation of each individual parameter in the operating menu. The description is aimed at those who work with the device over the entire life cycle and perform specific configurations.

Safety Instructions (XA)

Depending on the approval, Safety Instructions (XA) are supplied with the device. The Safety Instructions are an integral part of the Operating Instructions.



Information on the Safety Instructions (XA) that are relevant for the device is provided on the nameplate.

List of abbreviations

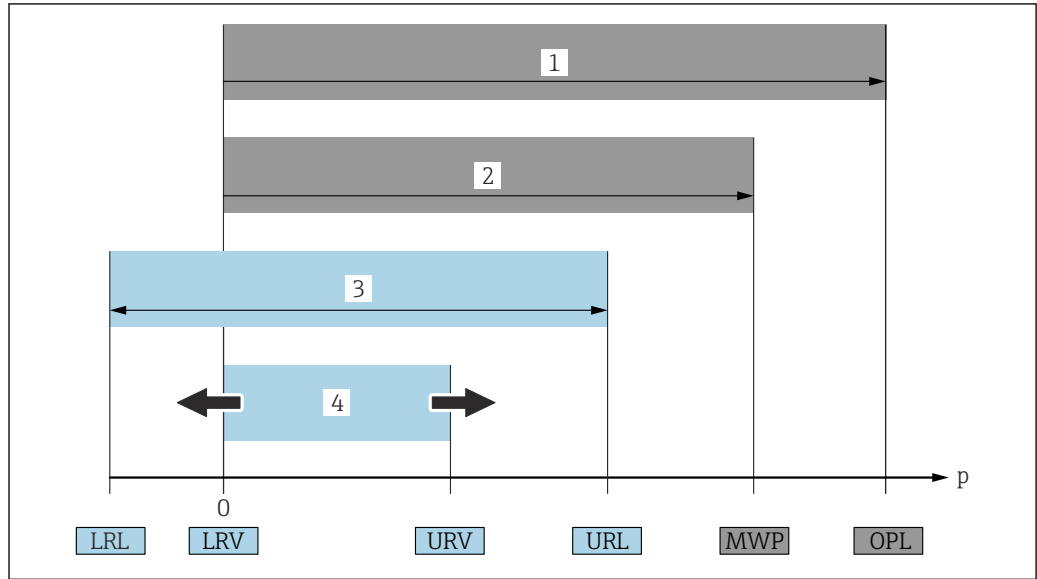

A0029505

- 1 OPL: The OPL (overpressure limit = measuring cell overload limit) for the device depends on the lowest-rated element, with regard to pressure, of the selected components, i.e. the process connection has to be taken into consideration in addition to the measuring cell. Pay attention to the pressure/temperature dependency.
 - 2 The MWP (maximum working pressure) for the measuring cells depends on the lowest-rated element, with regard to pressure, of the selected components, i.e. the process connection has to be taken into consideration in addition to the measuring cell. Pay attention to the pressure/temperature dependency. The MWP may be applied at the device for an unlimited period of time. The MWP can be found on the nameplate.
 - 3 The maximum measuring range corresponds to the span between the LRL and URL. This measuring range is equivalent to the maximum calibratable/adjustable span.
 - 4 The calibrated/adjusted span corresponds to the span between the LRV and URV. Factory setting: 0 to URL. Other calibrated spans can be ordered as customized spans.
- p Pressure
 LRL Lower range limit
 URL Upper range limit
 LRV Lower range value
 URV Upper range value
 TD Turn down. Example - see the following section.

Turn down calculation

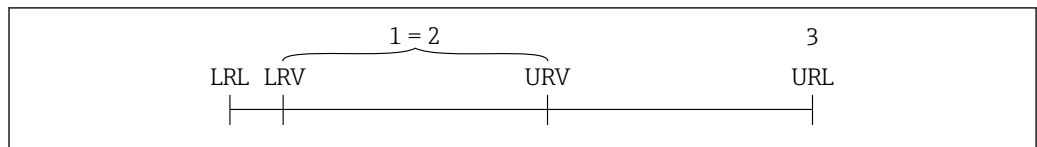

A0029545

- 1 Calibrated/adjusted span
- 2 Zero point-based span
- 3 Upper range limit

Example:

- Measuring cell: 10 bar (150 psi)
- Upper range limit (URL) = 10 bar (150 psi)
- Calibrated/adjusted span: 0 to 5 bar (0 to 75 psi)
- Lower range value (LRV) = 0 bar (0 psi)
- Upper range value (URV) = 5 bar (75 psi)

$$TD = \frac{URL}{|URV - LRV|}$$

In this example, the TD is 2:1. This span is based on the zero point.

Registered trademarks

HART®

Registered trademark of the FieldComm Group, Austin, USA

Function and system design

Measuring principle - electronic differential pressure measurement

FMD71 - Devices with ceramic process membrane (Ceraphire®)

The ceramic measuring cell is oil-free, i.e. the pressure acts directly on the robust ceramic process membrane and causes it to deflect. A pressure-dependent change in capacitance is measured at the electrodes of the ceramic substrate and the process membrane. The measuring range is determined by the thickness of the ceramic process membrane.

Advantages:

- Guaranteed overload resistance up to 40 times the nominal pressure
- The ultrapure 99.9 % ceramic (Ceraphire®, see also "www.endress.com/ceraphire") ensures:
 - Extremely high chemical durability
 - Less relaxation
 - High mechanical durability
- Can be used in absolute vacuum up to 150 °C (302 °F)
- Small measuring ranges

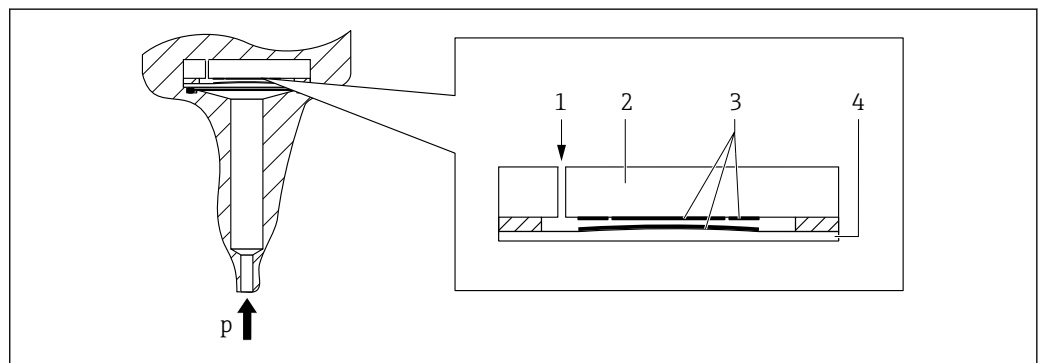

A0020465

- 1 Air pressure (gauge pressure sensors)
- 2 Ceramic substrate
- 3 Electrodes
- 4 Ceramic process membrane

FMD72 - Devices with metal process isolating diaphragm

The process pressure deflects the metal process isolating diaphragm of the sensor and a fill fluid transfers the pressure to a Wheatstone bridge (semiconductor technology). The pressure-dependent change in the bridge output voltage is measured and evaluated.

Advantages:

- Can be used for process pressures up to 40 bar (600 psi)
- Fully welded process isolating diaphragm
- Small, flush-mounted process connections
- Significantly reduced thermal effect e.g. compared to diaphragm seal systems with capillaries

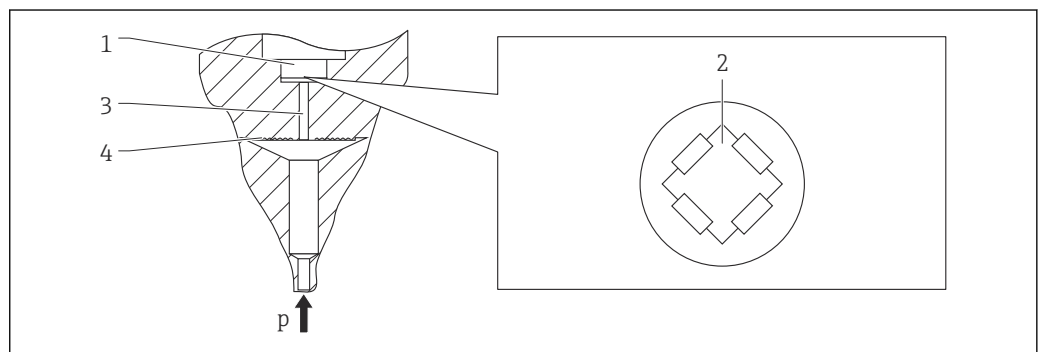

A0016448

- 1 Silicon measuring element, substrate
- 2 Wheatstone bridge
- 3 Channel with fill fluid
- 4 Metal process isolating diaphragm

Measuring system	The FMD71/FMD72 consists of 2 sensor modules and one transmitter. One sensor module measures the hydrostatic pressure (high pressure) and the other one the head pressure (low pressure). The level (electronic differential pressure) is calculated in the transmitter using these two digital values.
Device features	<p data-bbox="408 338 619 365">Field of application</p> <ul data-bbox="408 383 643 439" style="list-style-type: none"> ▪ Level ▪ Differential pressure <p data-bbox="408 472 628 499">Process connections</p> <ul data-bbox="408 517 783 595" style="list-style-type: none"> ▪ Thread ▪ EN and ASME flanges ▪ Flush mount hygienic connections <p data-bbox="408 629 852 656">Measuring ranges (differential pressure)</p> <p data-bbox="408 674 852 752">FMD71: from -100 to +100 mbar (-1.5 to +1.5 psi) to -1 to +40 bar (-15 to +600 psi)</p> <p data-bbox="408 770 812 848">FMD72: from -400 to +400 mbar (-6 to +6 psi) to -1 to +40 bar (-15 to +600 psi)</p> <p data-bbox="408 882 1326 938">MWP (depends on the lowest-rated element, with regard to pressure, of the selected components)</p> <p data-bbox="408 956 603 1012">FMD71: to 40 bar (600 psi)</p> <p data-bbox="408 1028 633 1084">FMD72: to 100 bar (1 500 psi)</p> <p data-bbox="408 1117 703 1144">Process temperature limits</p> <p data-bbox="408 1162 1102 1290">FMD71:</p> <ul data-bbox="408 1180 1102 1290" style="list-style-type: none"> ▪ Thread / flanges: -25 to +125 °C (-13 to +257 °F)/150 °C (302 °F) ▪ Hygienic process connections: -25 to +130 °C (-13 to +266 °F) , 150 °C (302 °F) for max. 1 hour <p data-bbox="408 1308 1243 1532">FMD72:</p> <ul data-bbox="408 1326 1243 1532" style="list-style-type: none"> ▪ Process connections with internal process membrane: -40 to +125 °C (-40 to +257 °F) ▪ Process connections with flush membrane: -40 to +100 °C (-40 to +212 °F) ▪ Hygienic process connections with flush membrane: -40 to +130 °C (-40 to +266 °F) , 150 °C (302 °F) for max. 1 hour ▪ Higher process temperature limits available on request (up to +400 °C (752 °F)) <p data-bbox="408 1565 716 1592">Ambient temperature range</p> <p data-bbox="408 1610 724 1637">-40 to +80 °C (-40 to +176 °F)</p> <p data-bbox="408 1671 890 1697">Reference accuracy of the individual sensors</p> <ul data-bbox="408 1715 943 1771" style="list-style-type: none"> ▪ Up to ±0.075% of the set span ▪ PLATINUM version: up to ±0.05 % of the set span <p data-bbox="408 1805 568 1832">Supply voltage</p> <ul data-bbox="408 1850 978 1906" style="list-style-type: none"> ▪ Version for non-hazardous areas: 12 (13) to 45 V DC ▪ Ex ia: 12 (13) to 30 V DC <p data-bbox="408 1939 488 1966">Output</p> <p data-bbox="408 1984 884 2011">4 to 20 mA with superimposed HART protocol</p>

Options

- NACE-compliant materials
- Software pre-configurations

Product design

Level measurement (level, volume and mass) with Deltabar:

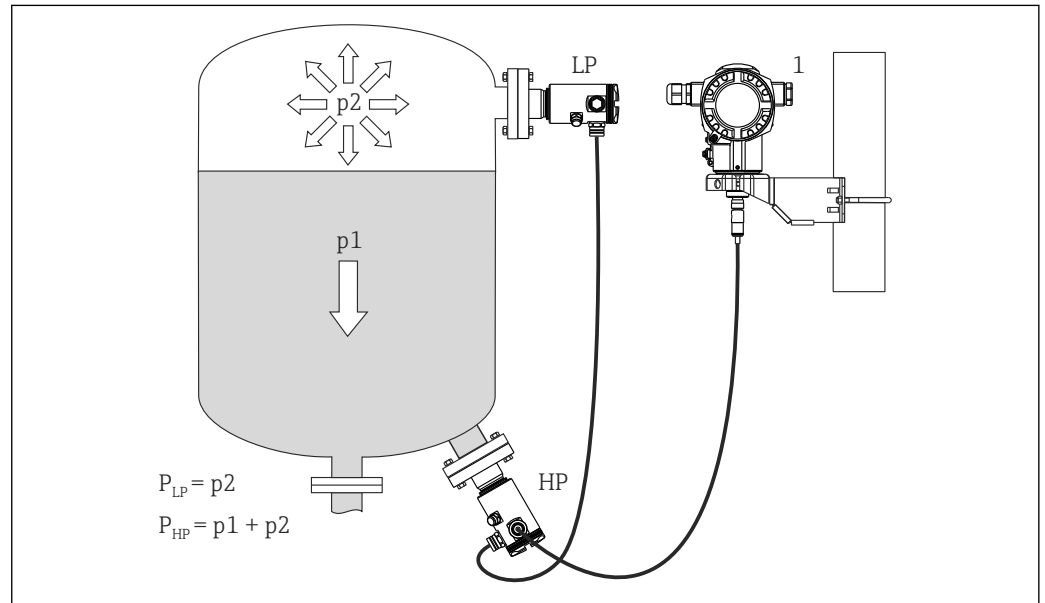

- LP* Sensor module LP (low pressure)
- HP* Sensor module HP (high pressure)
- p2* Head pressure
- p1* Hydrostatic pressure
- 1* Transmitter

The FMD71/FMD72 is best suited to level measurement in vessels with pressure overlay or in vacuum vessels and tanks, high distillation columns and other vessels with changing ambient temperatures.

The sensor module HP is mounted on the lower measuring connection and the sensor module LP is mounted above the maximum level. The transmitter can be mounted on pipes or walls with the mounting bracket.

The sensor signal is transmitted digitally. In addition, sensor temperatures and the individual process pressures present at the respective sensor modules can be individually evaluated and transmitted.

NOTICE

Incorrect sizing/order of sensor modules

- ▶ In a closed system, please note that the sensor module is affected by the superimposed head pressure (p_2) in addition to the hydrostatic pressure (p_1). This must be taken into account when sizing the sensor module on the high-pressure side (HP).

System integration

The device can be given a tag name (max. 8 alphanumeric characters).

Measuring point (TAG), see additional specifications.: Product Configurator order code for "Identification", option "Z1"

Input

Measured variable

Measured process variables

- Pressure HP and Pressure LP
- Sensor temperature HP and sensor temperature LP
- Transmitter temperature

Calculated process variables

- Differential pressure
- Level (level, volume or mass)

FMD71: measuring range of individual sensors



The maximum span of the differential pressure corresponds to the URL of the HP sensor.

Gauge pressure

Measuring cell	Maximum measuring range		MWP	OPL	Vacuum resistance	Option ¹⁾
	lower (LRL)	upper (URL)				
	[bar (psi)]	[bar (psi)]				
100 mbar (1.5 psi)	-0.1 (-1.5)	+0.1 (+1.5)	2.7 (40.5)	4 (60)	0.7 (10.5)	1C
250 mbar (4 psi)	-0.25 (-4)	+0.25 (+4)	3.3 (49.5)	5 (75)	0.5 (7.5)	1E
400 mbar (6 psi)	-0.4 (-6)	+0.4 (+6)	5.3 (79.5)	8 (120)	0	1F
1 bar (15 psi)	-1 (-15)	+1 (+15)	6.7 (100.5)	10 (150)	0	1H
2 bar (30 psi)	-1 (-15)	+2 (+30)	12 (180)	18 (270)	0	1K
4 bar (60 psi)	-1 (-15)	+4 (+60)	16.7 (250.5)	25 (375)	0	1M
10 bar (150 psi)	-1 (-15)	+10 (+150)	26.7 (400.5)	40 (600)	0	1P
40 bar (600 psi)	-1 (-15)	+40 (+600)	40 (600)	60 (900)	0	1S

1) Product Configurator, order code for "Sensor range"

Absolute pressure

Measuring cell	Maximum measuring range		MWP	OPL	Vacuum resistance	Option ¹⁾
	lower (LRL)	upper (URL)				
	[bar _{abs} (psi _{abs})]	[bar _{abs} (psi _{abs})]				
100 mbar (1.5 psi)	0	+0.1 (+1.5)	2.7 (40.5)	4 (60)	0	2C
250 mbar (4 psi)	0	+0.25 (+4)	3.3 (49.5)	5 (75)	0	2E
400 mbar (6 psi)	0	+0.4 (+6)	5.3 (79.5)	8 (120)	0	2F
1 bar (15 psi)	0	+1 (+15)	6.7 (100.5)	10 (150)	0	2H
2 bar (30 psi)	0	+2 (+30)	12 (180)	18 (270)	0	2K
4 bar (60 psi)	0	+4 (+60)	16.7 (250.5)	25 (375)	0	2M
10 bar (150 psi)	0	+10 (+150)	26.7 (400.5)	40 (600)	0	2P
40 bar (600 psi)	0	+40 (+600)	40 (600)	60 (900)	0	2S

1) Product Configurator, order code for "Sensor range"

FMD72: measuring range of individual sensors



The maximum span of the differential pressure corresponds to the URL of the HP sensor.

Gauge pressure

Sensor	Maximum sensor measuring range		MWP	OPL	Vacuum resistance ¹⁾	Option ²⁾
	lower (LRL)	upper (URL)			silicone oil	
	[bar (psi)]	[bar (psi)]			[bar _{abs} (psi _{abs})]	
400 mbar (6 psi)	-0.4 (-6)	+0.4 (+6)	4 (60)	6 (90)	0.01 (0.15)	1F
1 bar (15 psi)	-1 (-15)	+1 (+15)	6.7 (100)	10 (150)	0.01 (0.15)	1H
2 bar (30 psi)	-1 (-15)	+2 (+30)	13.3 (200)	20 (300)	0.01 (0.15)	1K
4 bar (60 psi)	-1 (-15)	+4 (+60)	18.7 (280.5)	28 (420)	0.01 (0.15)	1M
10 bar (150 psi)	-1 (-15)	+10 (+150)	26.7 (400.5)	40 (600)	0.01 (0.15)	1P
40 bar (600 psi)	-1 (-15)	+40 (+600)	100 (1500)	160 (2400)	0.01 (0.15)	1S

- 1) The vacuum resistance applies for the measuring cell under reference operating conditions. (see "Reference operating conditions" section)
- 2) Product Configurator order code for "Sensor range"

Absolute pressure

Sensor	Maximum sensor measuring range		MWP	OPL	Vacuum resistance ¹⁾	Option ²⁾
	lower (LRL)	upper (URL)			silicone oil	
	[bar _{abs} (psi _{abs})]	[bar _{abs} (psi _{abs})]			[bar _{abs} (psi _{abs})]	
1 bar (15 psi)	0	+1 (+15)	6.7 (100)	10 (150)	0.01 (0.15)	2H
2 bar (30 psi)	0	+2 (+30)	13.3 (200)	20 (300)	0.01 (0.15)	2K
4 bar (60 psi)	0	+4 (+60)	18.7 (280.5)	28 (420)	0.01 (0.15)	2M
10 bar (150 psi)	0	+10 (+150)	26.7 (400.5)	40 (600)	0.01 (0.15)	2P
40 bar (600 psi)	0	+40 (+600)	100 (1500)	160 (2400)	0.01 (0.15)	2S

- 1) The vacuum resistance applies for the measuring cell under reference operating conditions. (see "Reference operating conditions" section)
- 2) Product Configurator order code for "Sensor range"

Output

Output signal 4 to 20 mA with superimposed digital communication protocol HART 6.0, 2-wire

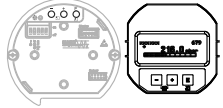
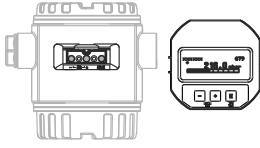
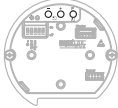
Operation	Internal + LCD	External ¹⁾ + LCD	Internal
			
Product Configurator: Order code 030	4	5	8

A0021280

1) In the case of the T17 transmitter housing, the operating keys are always arranged internally on the electronic insert.

Signal range 4 to 20 mA 3.8 to 20.5 mA

Signal on alarm 4 to 20 mA As per NAMUR NE43

- Max. alarm (factory setting 22 mA): can be set from 21 to 23 mA
- Hold measured value: last measured value is held
- Min. alarm: 3.6 mA

Maximum load

In order to guarantee sufficient terminal voltage in two-wire devices, a maximum load resistance R (including line resistance) must not be exceeded depending on the supply voltage U_0 of the supply unit. In the following load diagrams, observe the position of the jumper and the explosion protection:

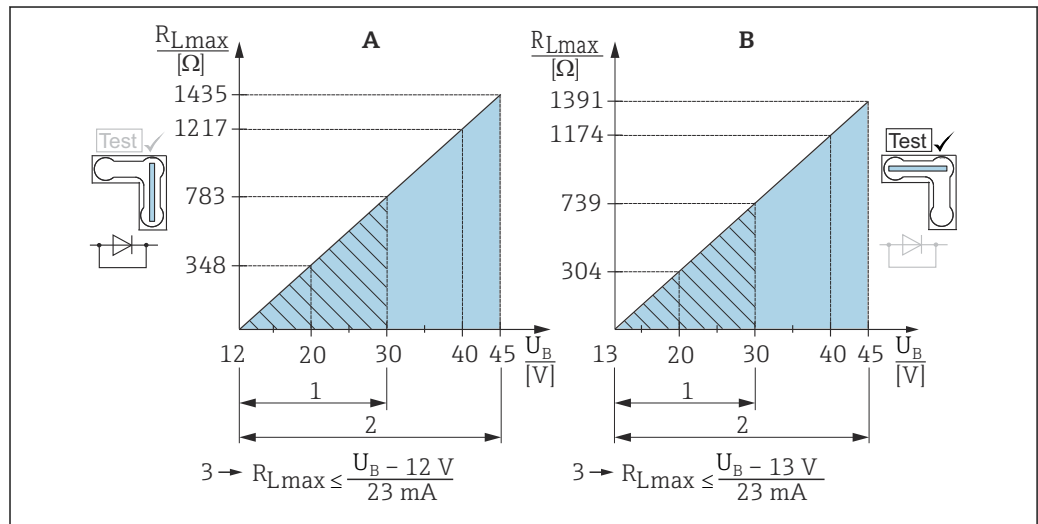

A0017533

- A Jumper for 4 to 20 mA test signal set to "Non-Test" position
- B Jumper for 4 to 20 mA test signal set to "Test" position
- 1 Power supply for II 1/2 G Ex ia, FM IS, CSA IS
- 2 Power supply for devices for the non-hazardous area, 2 G Ex d, 3 G Ex nA, FM XP, FM NI, CSA XP, CSA dust ignition-proof
- 3 R_{Lmax} maximum load resistance
- U_B Supply voltage

i When operating using a handheld terminal or a PC with an operating program, a minimum communication resistance of 250 Ω has to be taken into account.

Dead time, time constant

Presentation of the dead time and the time constant:

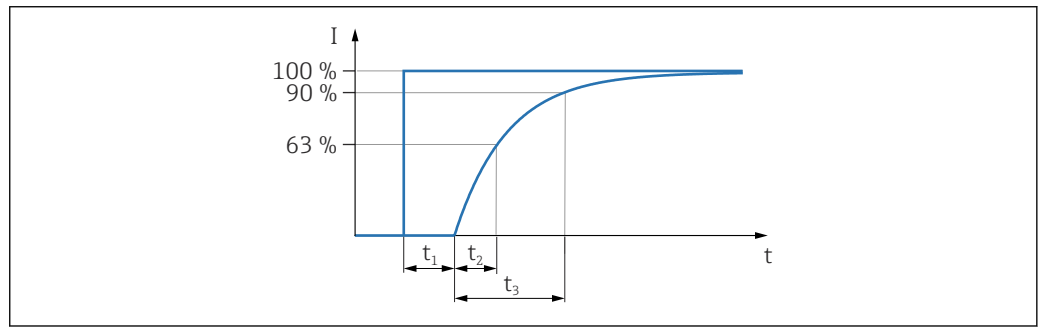

A0019786

Dynamic behavior, current output

	Dead time (t_1) [ms]	Time constant (T63), t_2	Time constant (T90), t_3
Max.	120	120	280

Dynamic behavior, HART

	Dead time (t_1) [ms]	Dead time (t_1) [ms] + Time constant T63 (= t_2) [ms]	Dead time (t_1) [ms] + Time constant T90 (= t_3) [ms]
Min.	280	400	560
Max.	1100	1220	1380

Read cycle

- Acyclic: max. 3/s, typically 1/s (depending on command # and number of preambles)
- Cyclic (burst): max. 3/s, typically 2/s

The Deltabar FMD71/FMD72 offers BURST MODE functionality for cyclical value transmission via the HART communication protocol.

Cycle time (update time)

Cyclic (burst): min. 300 ms

Response time

- Acyclic: min. 330 ms, typically 590 ms (depending on command # and number of preambles)
- Cyclic (burst): min. 160 ms, typically 350 ms (depending on command # and number of preambles)

Damping

A damping affects all outputs (output signal, display):

- Via local display, handheld terminal or PC with operating program, infinitely variable 0 to 999 s
- Via DIP switch on the electronic insert, switch position "on" = set value and "off"
- Factory setting: 2 s

Damping can be switched on or off using a switch on the electronic insert. If the switch is on, the time constant can be set via a parameter in the menu and if the switch is off, the output signal is not damped (time constant = 0.0).

Alarm current

Set min. alarm current: Product Configurator, order code 570

Firmware version

Designation	Product Configurator: Feature 850, variant:
01.00.zz, HART, DevRev01	78

Wireless HART data

- Minimum start-up voltage: 13 V
- Start-up current: 12 mA (default) or 22 mA (customer setting)
- Start-up time: 10 s
- Minimum operating voltage: 13 V
- Multidrop current: 4 mA
- Time to establish connection: 0 s

Protocol-specific data

Manufacturer ID	17 (0x11)
Device type ID	39 (0x27)
HART specification	6.0
Device description files (DTM, DD)	Information and files available at: <ul style="list-style-type: none"> ▪ www.endress.com ▪ www.fieldcommgroup.org/registered-products
HART device variables	<p>Measured values for PV (primary variable)</p> <ul style="list-style-type: none"> ▪ Differential pressure ▪ Level linear (before lin.) ▪ Level after linearization table <p>Measured values for SV, TV, QV (second, third and fourth variable)</p> <ul style="list-style-type: none"> ▪ Measured differential pressure ▪ Corrected pressure ▪ Measured pressure HP ▪ Sensor pressure HP ▪ Sensor temperature HP ▪ Measured pressure LP ▪ Sensor pressure LP ▪ Sensor temperature LP ▪ Level before linearization ▪ Tank content ▪ Electronic temperature
Supported functions	<ul style="list-style-type: none"> ▪ Burst mode ▪ Additional transmitter status

Energy supply

⚠ WARNING

Electrical safety is compromised by an incorrect connection!

- ▶ In accordance with IEC/EN61010 a separate circuit breaker must be provided for the device .
- ▶ When using the measuring device in hazardous areas, installation must comply with the corresponding national standards and regulations and the Safety Instructions or Installation or Control Drawings.
- ▶ All explosion protection data are given in separate documentation which is available upon request. The Ex documentation is supplied as standard with all devices approved for use in explosion hazardous areas.
- ▶ Devices with integrated overvoltage protection must be grounded.
- ▶ Protective circuits against reverse polarity, HF influences and overvoltage peaks are integrated.

Terminals

- Supply voltage and internal ground terminal: 0.5 to 2.5 mm² (20 to 14 AWG)
- External ground terminal: 0.5 to 4 mm² (20 to 12 AWG)

Terminal assignment

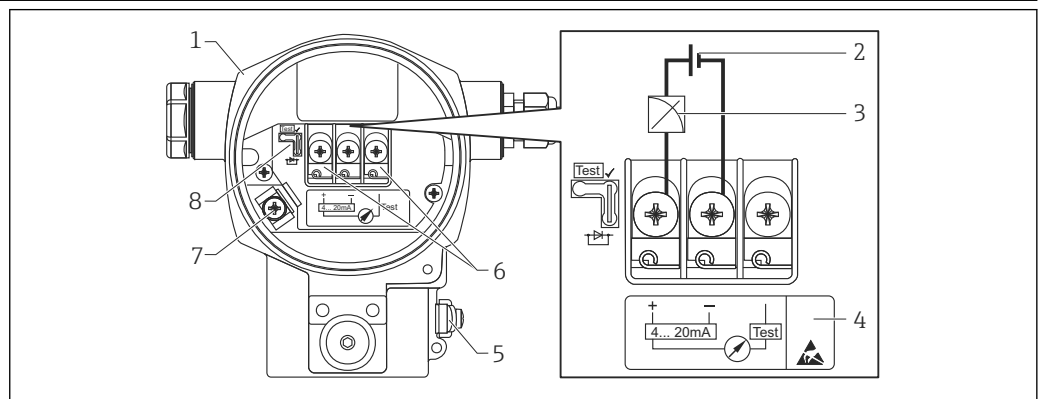

A0019989



- 1 Housing
- 2 Supply voltage
- 3 4 to 20 mA
- 4 Devices with integrated overvoltage protection are labeled "OVP" (overvoltage protection) here.
- 5 External ground terminal
- 6 4 to 20 mA test signal between positive and test terminal
- 7 Internal ground terminal, minimum supply voltage = 12 V_{DC} jumper is inserted as illustrated in the graphic.
- 8 Jumper for 4 to 20 mA test signal

Supply voltage

Electronic version	Jumper for 4 to 20 mA test signal in "Test" position (as-delivered state)	Jumper for 4 to 20 mA test signal in "Non-Test" position
4 to 20 mA HART, version for non-hazardous area	13 to 45 V _{DC}	12 to 45 V _{DC}

Measuring a 4 to 20 mA test signal

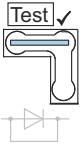
A 4 to 20 mA test signal may be measured via the positive and test terminal without interrupting the measurement. The minimum supply voltage of the device can be reduced by simply changing the position of the jumper. As a result, operation is also possible with a lower supply voltage. To keep the measurement error below 0.1 %, the current measuring instrument should exhibit an internal resistance of <0.7Ω. Observe the position of the jumper in accordance with the following table.

Jumper position for test signal	Description
 <p>A0019992</p>	<ul style="list-style-type: none"> ▪ Possible to measure 4 to 20 mA test signal via positive and test terminal. (Thus, the output current can be measured without interruption via the diode.) ▪ As-delivered state ▪ Minimum supply voltage: 13 V_{DC}
 <p>A0019993</p>	<ul style="list-style-type: none"> ▪ Not possible to measure 4 to 20 mA test signal via positive and test terminal. ▪ Minimum supply voltage: 12 V_{DC}

Cable entries

Type of protection	Cable gland	Permitted cable diameter	Permitted wire cross-sections
<ul style="list-style-type: none"> ▪ Standard ▪ Ex ia ▪ Ex ic 	Plastic M20x1.5	5 to 10 mm (0.2 to 0.39 in)	0.5 to 2.5 mm ² (20 to 14 AWG)
<ul style="list-style-type: none"> ▪ Ex tD ▪ Ex nA ▪ FM approval ▪ CSA approval 	Metal M20 x 1.5	7 to 10.5 mm (0.28 to 0.41 in)	

Cable specification for transmitter connection

- Endress+Hauser recommends using twisted, shielded two-wire cables.
- Terminals for core cross-sections 0.5 to 2.5 mm² (20 to 14 AWG)
- The cable outer diameter depends on the cable entry used.

Residual ripple

Without influence on 4 to 20 mA signal up to 5 % residual ripple within the permitted voltage range [according to HART hardware specification HCF_SPEC-54 (DIN IEC 60381-1)]

Influence of power supply

≤0.0006 % of the URV/1 V

Overvoltage protection

Standard version

The standard version of the pressure instruments does not contain any special elements to protect against overvoltage ("wire to ground"). Nevertheless the requirements of the applicable EMC standard EN 61000-4-5 (testing voltage 1kV EMC wire/ground) are met.

Optional overvoltage protection

Devices showing version "NA" in feature 610 in the order code are equipped with overvoltage protection.

- Overvoltage protection:
 - Nominal functioning DC voltage: 600 V
 - Nominal discharge current: 10 kA
- Surge current check $\hat{i} = 20$ kA satisfied as per DIN EN 60079-14: 8/20 μ s
- Arrester AC current check $I = 10$ A satisfied

NOTICE

Device could be destroyed!

- ▶ Devices with integrated overvoltage protection must be grounded.

Performance characteristics of the ceramic process membrane

Reference operating conditions

- As per IEC 60770
- Ambient temperature T_A = constant, in the range: +21 to +33 °C (+70 to +91 °F)
- Humidity ϕ = constant, in the range: 5 to 80 % rH
- Atmospheric pressure p_A = constant, in the range: 860 to 1060 mbar (12.47 to 15.37 psi)
- Position of the measuring cell = constant, in the range: horizontal $\pm 1^\circ$ (see also "Influence of the installation position" section → 17)
- Input of Lo Trim Sensor and Hi Trim Sensor for lower range value and upper range value
- Zero-point based span
- Material of process membrane: Al_2O_3 (aluminum-oxide ceramic, Ceraphire®)
- Supply voltage: 24 V DC ± 3 V DC
- Load for HART: 250 Ω

Influence of the installation position depending on sensor

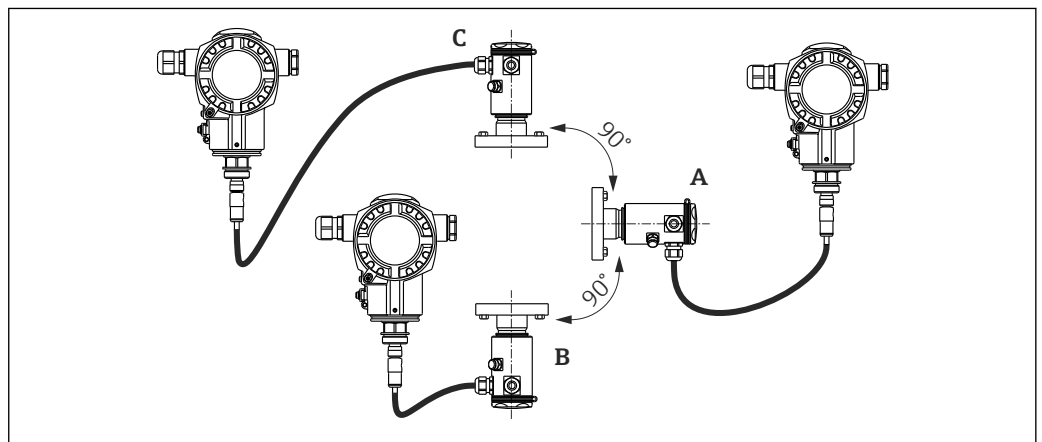

A0016465

Process membrane axis is horizontal (A)	Process membrane pointing upwards (B)	Process membrane pointing downwards (C)
Calibration position, no measurement error	< +0.2 mbar (+0.003 psi)	< -0.2 mbar (-0.003 psi)

This effect can be corrected using the function to adjust the position (position adjustment) for the differential pressure. Additional position adjustments for individual pressure signals are not available.

 A position-dependent zero shift can be corrected on the device.

Resolution

- Current output: 1 μA
- Display: can be set (factory setting: presentation of the maximum accuracy of the transmitter)

Vibration effects

Test standard	Vibration effects
IEC 61298-3	\leq Reference accuracy up to 10 to 60 Hz: ± 0.35 mm (± 0.01 in); 60 to 500 Hz: 2 g

Application limits

A high ratio between the level and head pressure or between the differential pressure and static pressure can result in large measured errors. A maximum ratio of 1:10 is recommended. For calculation purposes, please use the free "Applicator" calculation tool, which is available online at "www.endress.com/applicator" or on CD-ROM.

Reference accuracy

The reference accuracy contains the non-linearity [DIN EN 61298-2 3.11] including the pressure hysteresis [DIN EN 61298-23.13] and non-repeatability [DIN EN 61298-2 3.11] in accordance with the limit point method as per [DIN EN 60770].

Measuring cell	Sensor	Reference accuracy (A) [%URL for every sensor]		Calculated reference accuracy (A _{Diff}) of the differential pressure
		Standard	Platinum	
100 mbar (1.5 psi)	Gauge pressure	A = ±0.075 A = ±0.15 ¹⁾	-	Calculation (mbar, bar or psi): $A_{Diff} = \sqrt{\left(\frac{A_{HP} \cdot URL_{HP}}{100}\right)^2 + \left(\frac{A_{LP} \cdot URL_{LP}}{100}\right)^2}$ A0016468
250 mbar (3.75 psi)	Gauge pressure	A = ±0.075 A = ±0.15 ¹⁾	-	
400 mbar (6 psi)	Gauge pressure	A = ±0.075 A = ±0.15 ¹⁾	-	
1 bar (15 psi) 2 bar (30 psi) 4 bar (60 psi) 10 bar (150 psi) 40 bar (600 psi)	Gauge pressure/ Absolute pressure	A = ±0.075 A = ±0.15 ¹⁾	A = ±0.05 ±0.075 ¹⁾	Percentage calculation of URL dP: $A_{Diff} [\%] = \frac{A_{Diff} \cdot 100}{P_{Diff}}$ A0016469

1) For hygienic process connections

Ordering Information

Description	Option ¹⁾
Platinum	D
Standard	G

1) Product Configurator order code for "Reference accuracy"

Thermal change in the zero output and the output span

Standard version

Measuring cell	-10 °C (+14 °F) to ≤ +60 °C (+140 °F)	-20 to -10 °C (-4 to +14 °F) > +60 to +125 °C (+140 to +257 °F)	Calculated thermal change (T _{Diff}) of the differential pressure
	% of the set span for every sensor		
100 mbar (1.5 psi) 250 mbar (4 psi) 400 mbar (6 psi)	T _{total} = ±0.176	T _{total} = ±0.276	Calculation (mbar, bar or psi): $T_{Diff} = \sqrt{\left(\frac{T_{HP} \cdot URL_{HP}}{100}\right)^2 + \left(\frac{T_{LP} \cdot URL_{LP}}{100}\right)^2}$ A0016474 Percentage calculation of URL dP: $T_{Diff} [\%] = \frac{T_{Diff} \cdot 100}{P_{Diff}}$ A0016475
1 bar (15 psi) 2 bar (30 psi) 4 bar (60 psi) 10 bar (150 psi) 40 bar (600 psi)	T _{total} = ±0.092	T _{total} = ±0.250	

High temperature version and hygienic version

Measuring cell	Sensor	-10 °C (+14 °F) to ≤ +60 °C (+140 °F)	> +60 to +150 °C (140 to +302 °F)	Calculated thermal change (T _{Diff}) of the differential pressure
		% of the set span for every sensor		
100 mbar (1.5 psi) 250 mbar (4 psi) 400 mbar (6 psi)	Gauge pressure	T _{total} = ±0.176 T _{total} = ±0.352 ¹⁾	T = ±0.75 T = ±1.25 ¹⁾	Calculation (mbar, bar or psi): $T_{Diff} = \sqrt{\frac{(T_{HP} \cdot URL_{HP})^2}{100} + \frac{(T_{LP} \cdot URL_{LP})^2}{100}}$ A0016474 Percentage calculation of URL dP: $T_{Diff} [\%] = \frac{T_{Diff} \cdot 100}{P_{Diff}}$ A0016475
1 bar (15 psi) 2 bar (30 psi) 4 bar (60 psi) 10 bar (150 psi) 40 bar (600 psi)	Gauge pressure	T _{total} = ±0.092 T _{total} = ±0.184 ¹⁾	T = ±0.5 T = ±0.75 ¹⁾	
1 bar (15 psi) 2 bar (30 psi) 4 bar (60 psi) 10 bar (150 psi)	Absolute pressure	T _{total} = ±0.092 T _{total} = ±0.184 ¹⁾	T = ±0.75 T = ±1.25 ¹⁾	
40 bar (600 psi)	Absolute pressure	T _{total} = ±0.092 T _{total} = ±0.184 ¹⁾	T = ±0.5 T = ±0.75 ¹⁾	

1) For hygienic process connections

Total performance

The "Total performance" specification comprises the non-linearity including hysteresis, non-reproducibility as well as the thermal change in the zero point. All specifications apply to the temperature range -10 to +60 °C (+14 to +140 °F).

Measuring cell	% of URL for every sensor - standard version	% of URL for every sensor - high-temperature version	% of URL for every sensor - hygienic version	Calculated total performance (TP _{Diff}) of the differential pressure
100 mbar (1.5 psi) 250 mbar (4 psi) 400 mbar (6 psi)	TP = ±0.2	TP = ±0.46	TP = ±0.575	Calculation (mbar, bar or psi): $TP_{Diff} = \sqrt{\frac{(TP_{HP} \cdot URL_{HP})^2}{100} + \frac{(TP_{LP} \cdot URL_{LP})^2}{100}}$ A0016470 Percentage calculation of URL dP: $TP_{Diff} [\%] = \frac{TP_{Diff} \cdot 100}{P_{Diff}}$ A0016471
1 bar (15 psi) 2 bar (30 psi) 4 bar (60 psi) 10 bar (150 psi) 40 bar (600 psi)	TP = ±0.15	TP = ±0.46	TP = ±0.5	



The "Applicator Sizing Electronic dp" selection tool, available free of charge on the Endress+Hauser web site (www.endress.com/applicator), enables detailed calculations for your respective applications.

Long-term stability

Measuring ranges	Sensor	Standard version		Calculated long-term stability (L_{Diff}) of the differential pressure
		1 year	10 years	
		% of URL for every sensor		
100 mbar (1.5 psi) 250 mbar (4 psi) 400 mbar (6 psi)	Gauge pressure	L = ±0.1 L = ±0.25 ¹⁾	L = ±0.2 L = ±0.45 ¹⁾	Calculation (mbar, bar or psi): $L_{Diff} = \sqrt{\left(\frac{L_{HP} \cdot URL_{HP}}{100}\right)^2 + \left(\frac{L_{LP} \cdot URL_{LP}}{100}\right)^2}$ Percentage calculation of URL dP/year: $L_{Diff} [\%] = \frac{L_{Diff} \cdot 100}{P_{Diff}}$
	Absolute pressure		L = ±0.3 L = ±0.55 ¹⁾	
1 bar (15 psi) 2 bar (30 psi) 4 bar (60 psi) 10 bar (150 psi) 40 bar (600 psi)	Gauge pressure	L = ±0.05 L = ±0.1 ¹⁾	L = ±0.2	
	Absolute pressure		L = ±0.3	

A0016463

A0016464

1) For hygienic process connections

Total error

The total error comprises the total performance and long-term stability. All specifications apply to the temperature range -10 to +60 °C (+14 to +140 °F).

Measuring cell	% of URL for every sensor - standard version	% of URL for every sensor - high-temperature version	% of URL for every sensor - hygienic version	Calculated total error (TE_{Diff}) of the differential pressure
100 mbar (1.5 psi) 250 mbar (4 psi) 400 mbar (6 psi)	TE = ±0.25	TE = ±0.51	TE = ±0.925	Calculation (mbar, bar or psi): $TE_{Diff} = \sqrt{\left(\frac{TE_{HP} \cdot URL_{HP}}{100}\right)^2 + \left(\frac{TE_{LP} \cdot URL_{LP}}{100}\right)^2}$ Percentage calculation of URL dP: $TE_{Diff} [\%] = \frac{TE_{Diff} \cdot 100}{P_{Diff}}$
1 bar (15 psi) 2 bar (30 psi) 4 bar (60 psi) 10 bar (150 psi) 40 bar (600 psi)	TE = ±0.2	TE = ±0.51	TE = ±0.7	

A0016472

A0016473

Warm-up time

4 to 20 mA HART: < 10 s

Performance characteristics of metallic process membrane

Reference operating conditions

- As per IEC 60770
- Ambient temperature T_A = constant, in the range: +21 to +33 °C (+70 to +91 °F)
- Humidity ϕ = constant, in the range: 5 to 80 % rH
- Atmospheric pressure p_A = constant, in the range: 860 to 1060 mbar (12.47 to 15.37 psi)
- Position of the measuring cell = constant, in the range: horizontal $\pm 1^\circ$ (see also "Influence of the installation position" section → 21)
- Input of Lo Trim Sensor and Hi Trim Sensor for lower range value and upper range value
- Zero-point based span
- Material of the process membrane: AISI 316 (1.4435)
- Fill fluid: Silicone oil
- Supply voltage: 24 V DC ± 3 V DC
- Load for HART: 250 Ω

Influence of the installation position depending on sensor

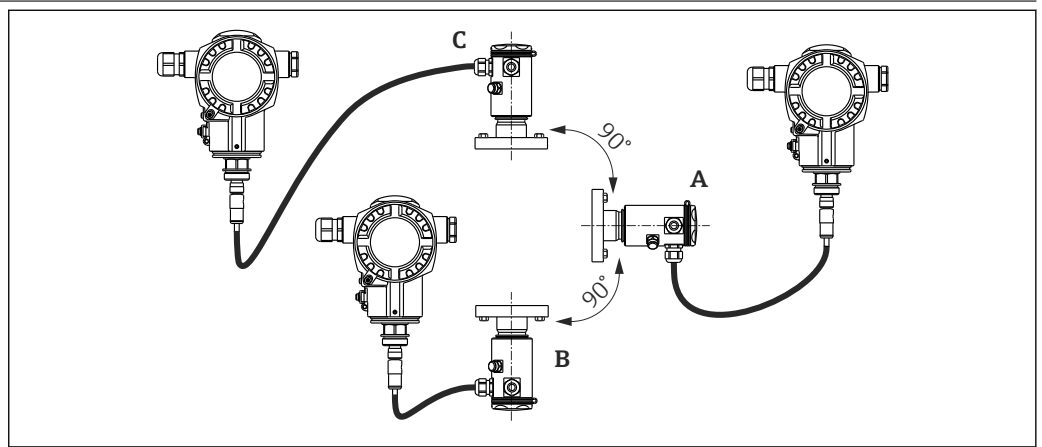

A0016465

	Process membrane axis is horizontal (A)	Process membrane pointing upwards (B)	Process membrane pointing downwards (C)
Sensor with 1/2" thread and silicone oil	Calibration position, no measurement error	< +4 mbar (+0.06 psi)	< -4 mbar (-0.06 psi)
Sensor with thread > 1/2" and flanges		< +10 mbar (+0.145 psi) This value is doubled for inert oil.	< -10 mbar (-0.145 psi) This value is doubled for inert oil.

This effect can be corrected using the function to adjust the position (position adjustment) for the differential pressure. Additional position adjustments for individual pressure signals are not available.

 A position-dependent zero point shift can be corrected at the device.

Resolution

- Current output: 1 μ A
- Display: can be set (factory setting: presentation of the maximum accuracy of the transmitter)

Vibration effects

Test standard	Vibration effects
IEC 61298-3	\leq Reference accuracy up to 10 to 60 Hz: ± 0.35 mm (± 0.01 in); 60 to 500 Hz: 2 g

Application limits

A high ratio between the level and head pressure or between the differential pressure and static pressure can result in large measurement errors. A maximum ratio of 1:10 is recommended. For calculation purposes, please use the free "Applicator" calculation tool, which is available online at "www.endress.com/applicator" or on CD-ROM.

Reference accuracy

The reference accuracy includes the non-linearity [DIN EN 61298-2 3.11] including the pressure hysteresis [DIN EN 61298-23.13] and non-repeatability [DIN EN 61298-2 3.11] in accordance with the limit point method as per [DIN EN 60770].

Measuring cell	Sensor	Reference accuracy (A) [%URL for every sensor]		Calculated reference accuracy (A _{Diff}) of the differential pressure
		Standard	Platinum	
400 mbar (6 psi)	Gauge pressure	A = ±0.15 ±0.3 ¹⁾	-	Calculation (mbar, bar or psi): $A_{Diff} = \sqrt{\left(\frac{A_{HP} \cdot URL_{HP}}{100}\right)^2 + \left(\frac{A_{LP} \cdot URL_{LP}}{100}\right)^2}$ Percentage calculation of URL dP: $A_{Diff} [\%] = \frac{A_{Diff} \cdot 100}{P_{Diff}}$
1 bar (15 psi) 2 bar (30 psi) 4 bar (60 psi) 10 bar (150 psi) 40 bar (600 psi)	Gauge pressure/ Absolute pressure	A = ±0.075 A = ±0.15 ¹⁾	A = ±0.05 A = ±0.075 ¹⁾	A0016468 A0016469

1) For hygienic process connections

Ordering information

Designation	Option ¹⁾
Platinum	D
Standard	G

1) Product Configurator, order code for "Reference accuracy"

Thermal change of the zero output and the output span

Measuring cell	-10 to +60 °C (+14 to +140 °F)	-40 to -10 °C (-40 to +14 °F) +60 to +80 °C (+140 to +176 °F)	Calculated thermal change (T _{Diff}) of the differential pressure
	% of the set span for every sensor		
400 mbar (6 psi)	T _{total} = ±0.215 T _{span} = ±0.2 T _{zero point} = ±0.015	T _{total} = ±0.43 T _{span} = ±0.4 T _{zero point} = ±0.03	Calculation (mbar, bar or psi): $T_{Diff} = \sqrt{\left(\frac{T_{HP} \cdot URL_{HP}}{100}\right)^2 + \left(\frac{T_{LP} \cdot URL_{LP}}{100}\right)^2}$ Percentage calculation of URL dP: $T_{Diff} [\%] = \frac{T_{Diff} \cdot 100}{P_{Diff}}$
1 bar (15 psi) 2 bar (30 psi) 4 bar (60 psi) 10 bar (150 psi) 40 bar (600 psi)	T _{total} = ±0.101 T _{span} = ±0.1 T _{zero point} = ±0.01	T _{total} = ±0.42 T _{span} = ±0.4 T _{zero point} = ±0.02	A0016474 A0016475

Total performance

The "Total performance" specification comprises the non-linearity including hysteresis, non-reproducibility as well as the thermal change in the zero point. All specifications apply to the temperature range -10 to +60 °C (+14 to +140 °F).

Measuring cell	% of URL for every sensor	Calculated total performance (TP _{Diff}) of the differential pressure
400 mbar (6 psi)	TP = ±0.25 TP = ±0.34 ¹⁾	Calculation (mbar, bar or psi):
1 bar (15 psi) 2 bar (30 psi) 4 bar (60 psi) 10 bar (150 psi) 40 bar (600 psi)	TP = ±0.15 TP = ±0.25 ¹⁾	$TP_{Diff} = \sqrt{\left(\frac{TP_{HP} \cdot URL_{HP}}{100}\right)^2 + \left(\frac{TP_{LP} \cdot URL_{LP}}{100}\right)^2}$ <p>Percentage calculation of URL dP:</p> $TP_{Diff} [\%] = \frac{TP_{Diff} \cdot 100}{P_{Diff}}$

1) For hygienic process connections



The "Applicator Sizing Electronic dp" selection tool, available free of charge on the Endress+Hauser web site (www.endress.com/applicator), enables detailed calculations for your respective applications.

Long-term stability

	1 year	5 years	10 years	Calculated long-term stability (L _{Diff}) of the differential pressure
Measuring ranges	% of URL for every sensor			
400 mbar (6 psi)	L = ±0.035 L = ±0.25 ¹⁾	L = ±0.14	L = ±0.32	Calculation (mbar, bar or psi):
1 bar (15 psi)	L = ±0.020 L = ±0.1 ¹⁾	L = ±0.08	L = ±0.180	$L_{Diff} = \sqrt{\left(\frac{L_{HP} \cdot URL_{HP}}{100}\right)^2 + \left(\frac{L_{LP} \cdot URL_{LP}}{100}\right)^2}$
2 bar (30 psi) 4 bar (60 psi) 10 bar (150 psi)	L = ±0.025 L = ±0.1 ¹⁾	L = ±0.05	L = ±0.075	Percentage calculation of URL dP/year:
40 bar (600 psi)	L = ±0.025 L = ±0.1 ¹⁾	L = ±0.075	L = ±0.100	$L_{Diff} [\%] = \frac{L_{Diff} \cdot 100}{P_{Diff}}$

1) For hygienic process connections

Total error

The total error comprises the total performance and long-term stability. All specifications apply to the temperature range -10 to +60 °C (+14 to +140 °F).

Measuring cell	% of URL/year for every sensor	Calculated total error (TE _{Diff}) of the differential pressure
400 mbar (6 psi)	TE = ±0.30	Calculation (mbar, bar or psi):
1 bar (15 psi) 2 bar (30 psi) 4 bar (60 psi) 10 bar (150 psi) 40 bar (600 psi)	TE = ±0.20	$TE_{Diff} = \sqrt{\left(\frac{TE_{HP} \cdot URL_{HP}}{100}\right)^2 + \left(\frac{TE_{LP} \cdot URL_{LP}}{100}\right)^2}$ <p>Percentage calculation of URL dP:</p> $TE_{Diff} [\%] = \frac{TE_{Diff} \cdot 100}{P_{Diff}}$

Warm-up time

4 to 20 mA HART : < 10 s

Installation

- Moisture must not penetrate the housing when mounting the device, establishing the electrical connection and during operation.
- When measuring in media containing solids, such as dirty liquids, installing separators and drain valves is useful for capturing and removing sediment.
- Point the cable and connector downwards where possible to prevent moisture from entering (e.g. rain or condensation water).

Mounting location

The FMD71/FMD72 is best suited to level measurement in vessels with pressure overlay or in vacuum vessels and tanks, high distillation columns and other vessels with changing ambient temperatures.

The sensor module HP is mounted on the lower measuring connection and the sensor module LP is mounted above the maximum level. The transmitter can be mounted on pipes or walls with the mounting bracket.

Orientation

- Transmitter: Any orientation.
- Sensor modules: The orientation can cause a zero point shift. This position-dependent zero point shift can be corrected directly at the device via the operating key, and also in hazardous areas in the case of devices with external operation (position adjustment).

General installation instructions

Mounting the sensor modules and transmitter is very easy

- The housings of the sensor modules can be rotated up to 360°.
- The transmitter is freely rotatable in the mounting bracket.

The sensor modules and transmitter can be easily aligned when mounted.

Your benefits

- Easy mounting due to optimum alignment of housing
- Easily accessible device operation
- Optimum readability of the onsite display (optional)
- Easy pipe installation due to optional alignment of the modules.

Thermal insulation - FMD71 high-temperature version

The FMD71 high-temperature version may only be insulated up to a certain height. The maximum permitted insulation height is indicated on the devices and applies to an insulation material with a heat conductivity $\leq 0.04 \text{ W}/(\text{m} \times \text{K})$ and to the maximum permitted ambient and process temperature. The insulation height is not indicated on hygienic connections.

- Ambient temperature (T_A): $\leq 70 \text{ °C}$ (158 °F)
- Process temperature (T_P): $\leq 150 \text{ °C}$ (302 °F)

The data were determined under the most critical application "quiescent air".

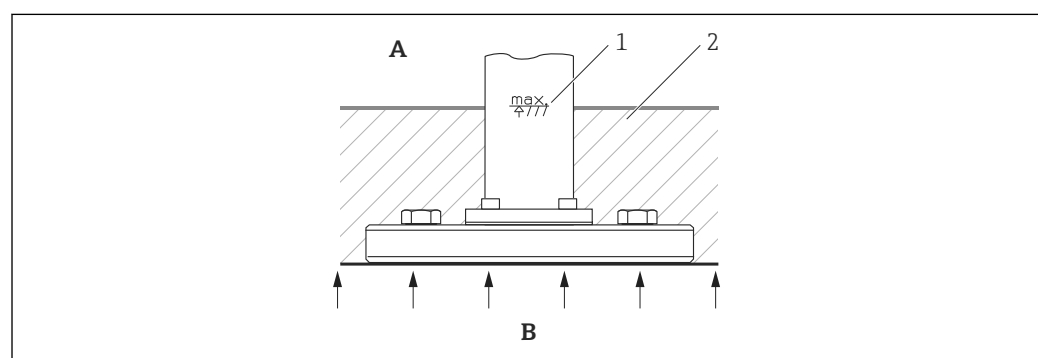

A0021075

- A Ambient temperature
 B Process temperature
 1 Insulation height
 2 Insulation material

Installing the sensor modules

General installation instructions

- Due to the orientation of the sensor modules, there may be a shift in the zero point, i.e. when the vessel is empty or partially full, the measured value does not display zero.
- Always install the sensor module HP below the lowest measuring point.
- Always install the sensor module LP above the highest measuring point.
- Do not mount the sensor modules in the filling curtain or at a point in the tank which could be affected by pressure pulses from an agitator.
- Do not mount the sensor modules in the suction area of a pump.
- The adjustment and functional test can be carried out more easily if you mount the sensor modules downstream of a shutoff device.

Mounting sensor modules with PVDF installation coupling

⚠ WARNING

Risk of damage to process connection!

Risk of injury!

- ▶ Sensor modules with PVDF process connections with threaded connection must be installed with the mounting bracket provided!

The mounting bracket can be installed on pipes with a diameter of 1¼" to 2" or on walls.

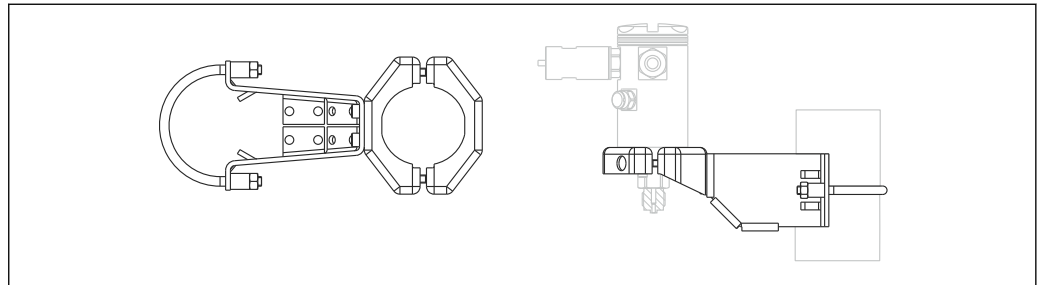

A0017514

- The mounting bracket is included in the delivery.
- Ordering information:
Product Configurator order code for "Enclosed accessories", option "PA" or as a separate accessory (part no.: 71102216).
- Dimensions → 55.

Installing the transmitter

The transmitter is installed with the mounting bracket supplied. The mounting bracket can be installed on pipes with a diameter of 1¼" to 2" or on walls.

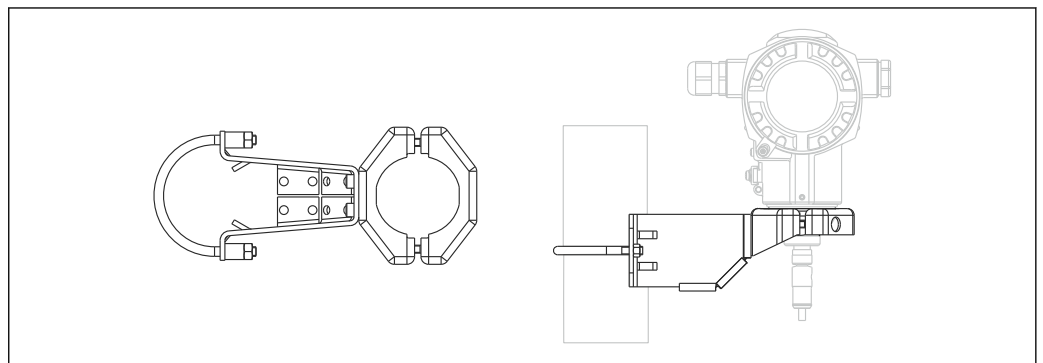

A0021145

- The mounting bracket is included in the delivery.
- If an additional mounting bracket is required, this can be ordered as follows:
Product Configurator order code for "Enclosed accessories", option "PA" or as separate accessory (part number: 71102216).
- Dimensions → 55.

Sensor and transmitter cable

Designation	Length	Option ¹⁾
Sensor cable PE-X	1.82 m (6 ft)	BC
	4.57 m (15 ft)	CC
	10.67 m (35 ft)	DC
	30.48 m (100 ft)	FC
	45.72 m (150 ft)	GC
Transmitter cable PE-X	1.82 m (6 ft)	BC
	4.57 m (15 ft)	CC
	10.67 m (35 ft)	DC

1) Product Configurator order code for "Cable length"

Technical data for PE-X cable:

- Temperature resistance: -40 to +80 °C (-40 to +176 °F)
- Flame resistance: to DIN 60332-1-2 and DIN EN 50266-2-5
- Halogen-free: to DIN VDE 0472 part 815
- Oil resistance: to DIN EN 60811-2-1
- Other: UV-resistant to DIN VDE 0276-605
- Bending radius: min. 34 mm (1.34 in), permanently installed



Cable shortening kit: SD00354P/00

Environment

Ambient temperature range

- Without onsite display: -40 to +80 °C (-40 to +176 °F)
- With onsite display: -20 to +70 °C (-4 to +158 °F)

Extended temperature operation range with limitations in optical properties, such as display speed and contrast. -40 to +80 °C (-40 to +176 °F)

For devices for use in hazardous areas, see Safety Instructions .

The device can be used in this temperature range. The values of the specification, such as thermal change, may be exceeded.

Storage temperature range -40 to +80 °C (-40 to +176 °F)

Climate class Class 4K4H (air temperature: -20 to +55 °C (-4 to +131 °F), relative humidity: 4 to 100 %) fulfilled as per DIN EN 60721-3-4 (condensation possible)

Degree of protection IP66/68 NEMA 4x/6P

Degree of protection IP 68: 1.83 mH2O for 24 h

Vibration resistance	Housing	Test standard	Vibration resistance
	Aluminum and steel housing	IEC 61298-3	guaranteed for: 10 to 60 Hz: ±0.15 mm (±0.0059 in); 60 to 500 Hz: 2 g in all 3 planes

Electromagnetic compatibility

- Electromagnetic compatibility as per EN 61326 Appendix A and NAMUR Recommendation EMC (NE21). For details, refer to the Declaration of Conformity.
- Maximum deviation: < 0.5 % of span
- All EMC measurements were performed with a turn down (TD) = 2:1.

Process

Process temperature range for devices with ceramic process membrane FMD71

- Thread and flanges: -25 to +125 °C (-13 to +257 °F)
- Hygienic connections: -25 to +130 °C (-13 to +266 °F) , 150 °C (302 °F) for max. 60 minutes
- High-temperature version: -15 to +150 °C (+5 to +302 °F); see ordering information, order code 610, option "NB".
- For saturated steam applications, use a device with a metallic process membrane, or provide a siphon for temperature isolation when installing.
- Observe the process temperature range of the seal. See also the following table.

Seal	Notes	Process temperature range		Option ¹⁾
		Threaded connection or flange	Hygienic process connections	
FKM	-	-25 to +125 °C (-13 to +257 °F)/ 150 °C (302 °F) ²⁾	-	A
FKM	FDA ³⁾ , 3A Class I, USP Class VI	-5 to +125 °C (+23 to +257 °F)	-5 to +150 °C (+23 to +302 °F)	B
FFKM Perlast G75LT	-	-20 to +125 °C (-4 to +257 °F)	-20 to +150 °C (-4 to +302 °F)	C
Kalrez, Compound 4079	-	+5 to +125 °C (+41 to +257 °F)/ 150 °C (302 °F) ²⁾	-	D
NBR	FDA ³⁾	-10 to +100 °C (+14 to +212 °F)	-	F
NBR, low temperature	-	-40 to +100 °C (-40 to +212 °F)	-	H
HNBR ⁴⁾	FDA ³⁾ , 3A Class II, AFNOR, BAM	-25 to +125 °C (-13 to +257 °F)/ 150 °C (302 °F) ²⁾	-20 to +125 °C (-4 to +257 °F)	G
EPDM 70	FDA ³⁾	-40 to +125 °C (-40 to +257 °F)	-	J
EPDM 291 ⁴⁾	FDA ³⁾ , 3A Class II, USP Class VI, DVGW, KTW, W270, WRAS, ACS, NSF61	-15 to +125 °C (+5 to +257 °F)/ 150 °C (302 °F) ²⁾	-15 to +150 °C (+5 to +302 °F)	K
FFKM Kalrez 6375	-	+5 to +125 °C (+41 to +257 °F)	-	L
FFKM Kalrez 7075	-	+5 to +125 °C (+41 to +257 °F)	-	M
FFKM Kalrez 6221	FDA ³⁾ , USP Class VI	-5 to +125 °C (+23 to +257 °F)	-5 to +150 °C (+23 to +302 °F)	N
Fluoroprene XP40	FDA ³⁾ , USP Class VI, 3A Class I	+5 to +125 °C (+41 to +257 °F)/ 150 °C (302 °F) ²⁾	+5 to +150 °C (+41 to +302 °F)	P
VMQ silicone	FDA ³⁾	-35 to +85 °C (-31 to +185 °F)	-20 to +85 °C (-4 to +185 °F)	S

The process temperature ranges indicated here refer to the permanent operation of the FMD71. In the case of devices with hygienic process connections, a higher temperature (max. 150 °C (302 °F)) may be applied for a short period (max. 60 min.) for cleaning purposes.

- 1) Product Configurator, order code for "Seal"
- 2) 150 °C (302 °F) for high-temperature version
- 3) Food-safe FDA 21 CFR 177.2600
- 4) These seals are used for devices with 3A-approved process connections.

Applications with changes in temperature

Frequent extreme changes in temperatures can temporarily cause measurement errors. Temperature compensation occurs after a few minutes. The smaller the change in temperature and the longer the time interval involved, the faster internal temperature compensation occurs.

Process temperature range for devices with metallic process membrane FMD72

Device	Limits
Process connections with internal process membrane	-40 to +125 °C (-40 to +257 °F)
Process connections with flush process membrane	-40 to +100 °C (-40 to +212 °F)
Hygienic process connections with flush process membrane	-40 to +130 °C (-40 to +266 °F) For a maximum of 60 minutes: +150 °C (+302 °F)

Pressure specifications**⚠ WARNING**

The maximum pressure for the measuring instrument depends on the lowest-rated element with regard to pressure.

- ▶ For pressure specifications, see the "Measuring range" section and the "Mechanical construction" section.
- ▶ MWP (maximum working pressure): The MWP (maximum working pressure) is specified on the nameplate. This value refers to a reference temperature of +20 °C (+68 °F) and may be applied to the device for an unlimited time. Observe the temperature dependency of the MWP. For the pressure values permitted at higher temperatures for flanges, please refer to standards EN 1092-1 (with regard to their stability-temperature property, the materials 1.4435 and 1.4404 are grouped together under EN 1092-1; the chemical composition of the two materials can be identical.), ASME B 16.5a, JIS B 2220 (the latest version of the standard applies in each case).
- ▶ The test pressure corresponds to the overload limit of the individual sensors (overpressure limit $OPL = 1.5 \times MWP$ (formula does not apply to the FMD72 with a 40 bar (600 psi) measuring cell)) and may be applied for a limited period only to ensure that no lasting damage occurs.
- ▶ The Pressure Equipment Directive (EC Directive 97/23/EC) uses the abbreviation "PS". The abbreviation "PS" corresponds to the MWP (maximum working pressure) of the measuring instrument.
- ▶ In the case of measuring cell range and process connection combinations where the overpressure limit (OPL) of the process connection is less than the nominal value of the measuring cell, the device is set at the factory, at the very maximum, to the OPL value of the process connection. If the entire measuring cell range must be used, select a process connection with a higher OPL value ($1.5 \times MWP$; $MWP = PN$).
- ▶ Devices with ceramic process membrane: Avoid steam hammering! Steam hammering can cause zero point drift. Recommendation: Residue (such as condensation or drops of water) can remain on the process membrane after CIP cleaning and lead to local steam hammering if steam cleaning is performed again. In practice, drying the process membrane (e.g. by blowing off excess moisture) has proven to be a successful way of avoiding steam hammering.

Mechanical construction

Device height

The device height is calculated from

- the height of the housing and
- the height of the individual process connection.

The individual heights of the components are listed in the following sections. To calculate the device height simply add up the individual heights of the components. Where applicable also take into consideration the installation distance (space that is used to install the device). You can use the following table for this purpose:

Section	Page	Height	Example
Transmitter height	→ 31 ff.	(A)	
Sensor height	→ 32	(B)	
Process connections	→ 33	(C)	
Installation distance	-	(D)	
Device height			A0021292

**T14 transmitter housing
(optional display on the side)**

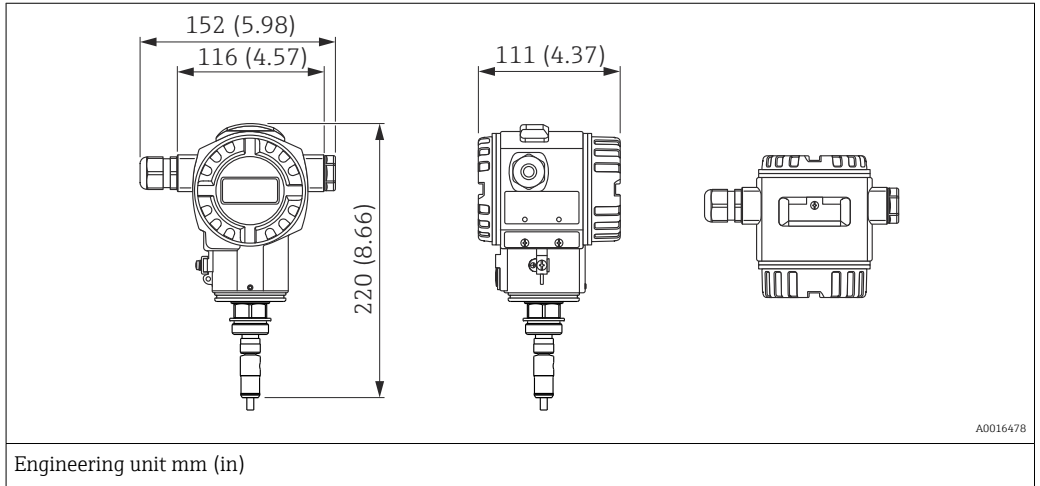

Material	Degree of protection	Cable entry	Weight kg (lbs)		Option ¹⁾
			With display	Without display	
Aluminum	IP66/68 NEMA 4x/6P	<ul style="list-style-type: none"> ■ M20 ■ G ½" ■ NPT ½" 	1.7 (3.75)	1.6 (3.53)	A
Stainless steel	IP66/68 NEMA 4x/6P	<ul style="list-style-type: none"> ■ M20 ■ G ½" ■ NPT ½" 	2.6 (5.73)	2.5 (5.51)	B

1) Product Configurator, order code for "Housing transmitter"

**T17 transmitter housing
(optional display on the side)**

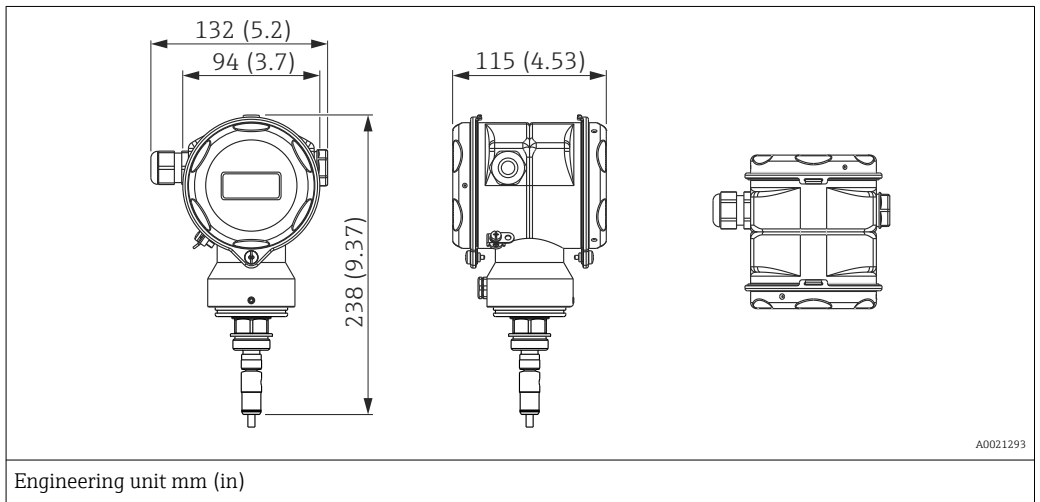

Material	Degree of protection	Cable entry	Weight kg (lbs)		Option ¹⁾
			with display	without display	
316L	IP66/68 NEMA 6P	<ul style="list-style-type: none"> ■ M20 ■ G ½" ■ NPT ½" 	2.6 (5.73)	2.5 (5.51)	C

1) Product Configurator order code for "Transmitter housing"

Sensor housing

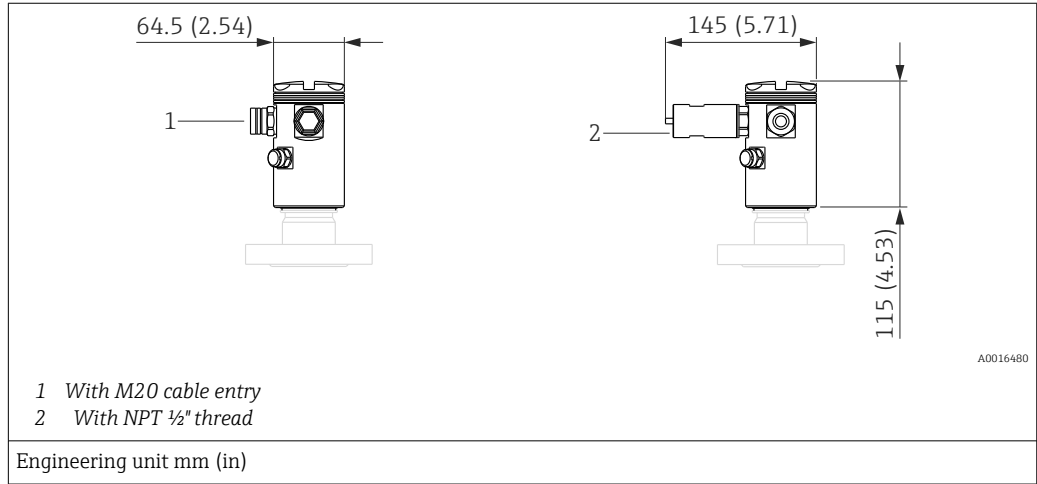

Material	Degree of protection	Cable entry	Weight	Option ¹⁾
			kg (lbs)	
Aluminum	IP66/68 NEMA 4x/6P	<ul style="list-style-type: none"> ■ M20 cable entry ■ NPT 1/2" 	0.6 (1.32)	A
Stainless steel	IP66/68 NEMA 4x/6P	<ul style="list-style-type: none"> ■ M20 cable entry ■ NPT 1/2" 	1.35 (2.98)	B

1) Product Configurator order code for "Sensor module housing"

Selecting the electrical connection

There is a dependency between the cable entries of the transmitter housing and those of the sensor module housing.

Different cable entries are available in the sensor module housing depending on the cable entry selected for the transmitter housing (see the following table):

Cable entry Transmitter housing	Cable entry Sensor module housing	Option ¹⁾
M20 cable entry	M20 cable entry	A
Thread G 1/2"	M20 cable entry	C
Thread NPT 1/2"	Thread NPT 1/2"	D

1) Product Configurator order code for "Electrical connection"

Explanation of terms

- DN or NPS or A = alphanumeric designation of the flange size
- PN or Class or K = alphanumeric pressure rating of a component

Process connections FMD71, internal process membrane **DIN 13 thread**

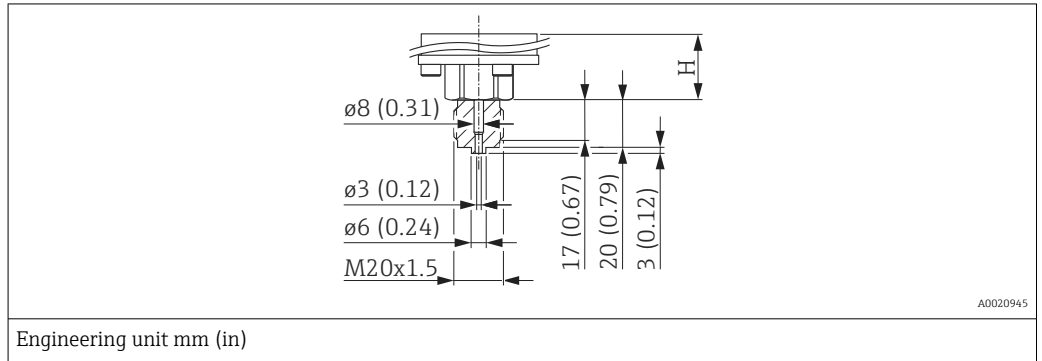

Designation	Material	Weight	Option ¹⁾
		kg (lbs)	
DIN 13 M20 x 1.5, EN 837 3 mm (0.12 in)	AISI 316L	0.63 (1.39)	G1J
	Alloy C276 (2.4819)		G2C

1) Product Configurator, order code for "Process connection"

Description	Height H
Standard height	29 mm (1.14 in)
High-temperature version	107 mm (4.21 in)

Process connections FMD71, ISO 228 G thread
internal process membrane

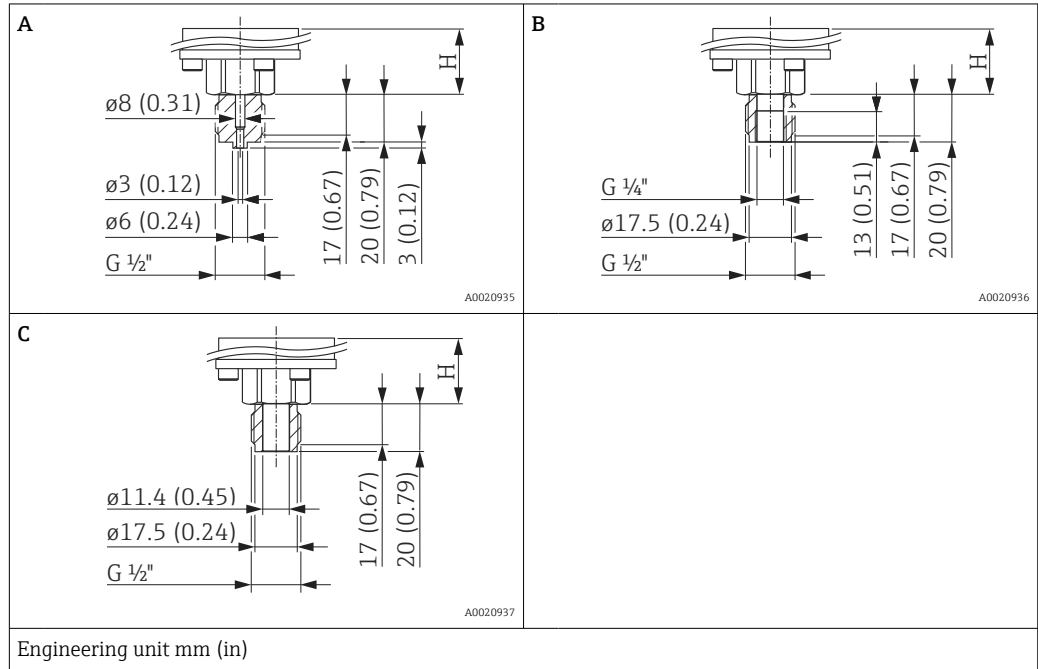

Item	Designation	Material	Weight	Option ¹⁾
			kg (lbs)	
A	ISO 228 G ½" A EN 837 thread	AISI 316L (CRN)	0.63 (1.39)	GCJ
		Alloy C276 (2.4819) (CRN)		GCC
		Monel (2.4360)		GCD
		PVDF <ul style="list-style-type: none"> ▪ Mount only with mounting bracket ▪ MWP 10 bar (150 psi), OPL max. 15 bar (225 psi) ▪ Process temperature range: +10 to +60 °C (+14 to +140 °F) 		GCF
B	ISO 228 G ½" A, G ¼" thread (female)	AISI 316L (CRN)	0.63 (1.39)	GLJ
		Alloy C276 (2.4819) (CRN)		GLC
		Monel (2.4360)		GLD
C	ISO 228 G ½" A thread, bore 11.4 mm (0.45 in)	AISI 316L (CRN)	0.63 (1.39)	GMJ
		Alloy C276 (2.4819) (CRN)		GMC
		Monel (2.4360)		GMD

1) Product Configurator, order code for "Process connection"

Description	Height H
Standard height	29 mm (1.14 in)
High-temperature version	107 mm (4.21 in)

Process connections FMD71, internal process membrane ANSI thread

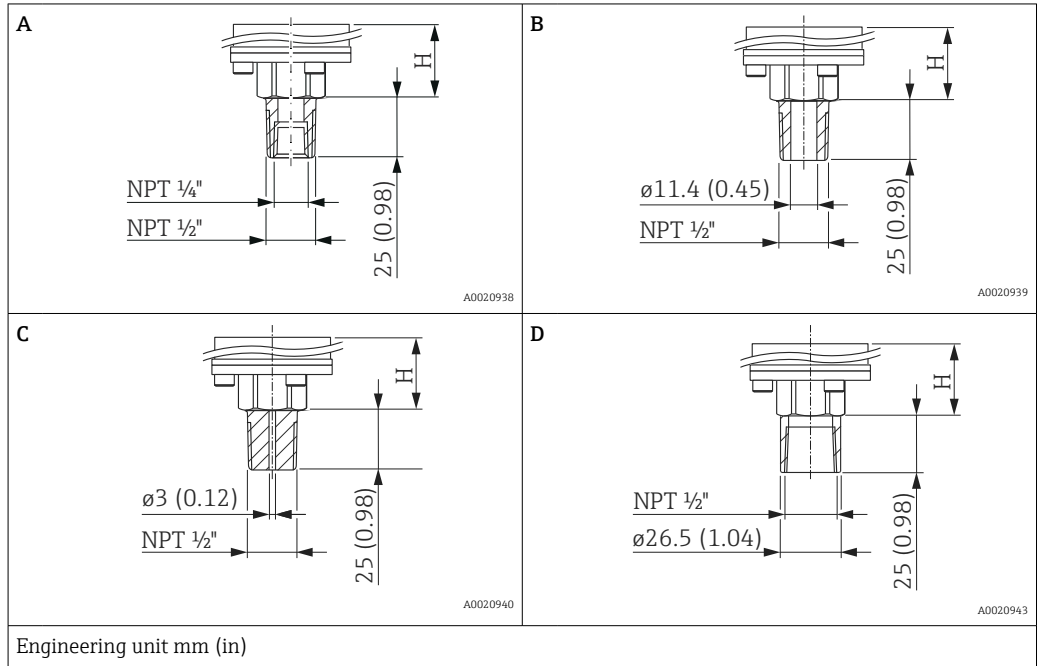

Item	Designation	Material	Weight	Approval ¹⁾	Option ²⁾
			kg (lbs)		
A	ANSI 1/2" MNPT, 1/4" FNPT	AISI 316L (CRN)	0.63 (1.39)	CRN	RLJ
		Alloy C276 (2.4819) (CRN)		CRN	RLC
		Monel (2.4360)		-	RLD
B	ANSI 1/2" MNPT, bore 11.4 mm (0.45 in)	AISI 316L (CRN)		CRN	RKJ
		Alloy C276 (2.4819) (CRN)		CRN	RKC
		Monel (2.4360)		-	RKD
C	ANSI 1/2" MNPT, bore 3 mm (0.12 in)	PVDF <ul style="list-style-type: none"> ■ Mount only with mounting bracket ■ MWP 10 bar (150 psi), OPL max. 15 bar (225 psi) ■ Process temperature range: +10 to +60 °C (+14 to +140 °F) 	-	RJF	
D	ANSI 1/2" FNPT 11.4 mm (0.45 in)	AISI 316L (CRN)	CRN	R1J	
		Alloy C276 (2.4819) (CRN)	CRN	R1C	
		Monel (2.4360)	-	R1D	

- 1) CSA approval: Product Configurator, order code for "Approval"
- 2) Product Configurator, order code for "Process connection"

Description	Height H
Standard version	29 mm (1.14 in)
High-temperature version	107 mm (4.21 in)

Process connections FMD71, ANSI thread
flush process membrane

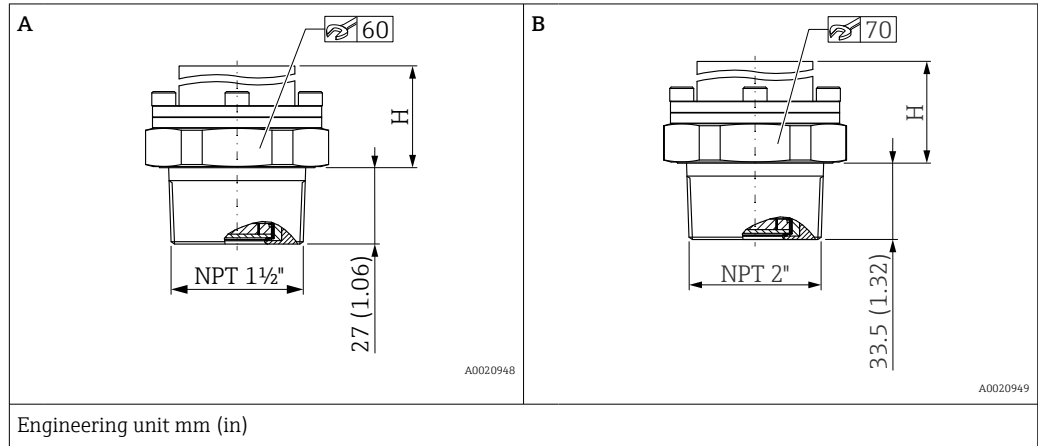

Item	Designation	Material	Weight	Option ¹⁾
			kg (lbs)	
A	ANSI 1 1/2" MNPT	AISI 316L (CRN)	0.63 (1.39)	U7J
		Alloy C276 (2.4819) (CRN)		U7C
		Monel (2.4360)		U7D
B	ANSI 2" MNPT	AISI 316L (CRN)		U8J
		Alloy C276 (2.4819) (CRN)		U8C
		Monel (2.4360)		U8D

1) Product Configurator, order code for "Process connection"

Item	Description	Height H
A	Standard version	57 mm (2.24 in)
	High-temperature version	64 mm (2.52 in)
B	Standard version	54 mm (2.13 in)
	High-temperature version	61 mm (2.4 in)

Process connections FMD71, DIN 13 thread
flush process membrane

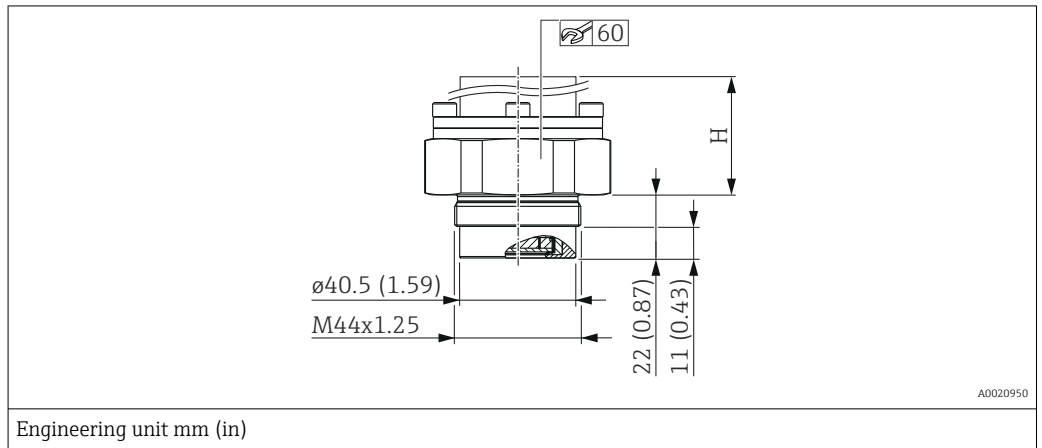

Designation	Material	Weight	Option ¹⁾
		kg (lbs)	
DIN 13 M44 x 1.25	AISI 316L	0.63 (1.39)	G4J
	Alloy C276 (2.4819)		G4C

1) Product Configurator, order code for "Process connection"

Description	Height H
Standard version	62 mm (2.44 in)
High-temperature version	69 mm (2.72 in)

Process connections FMD71, ISO 228 G thread
flush process membrane

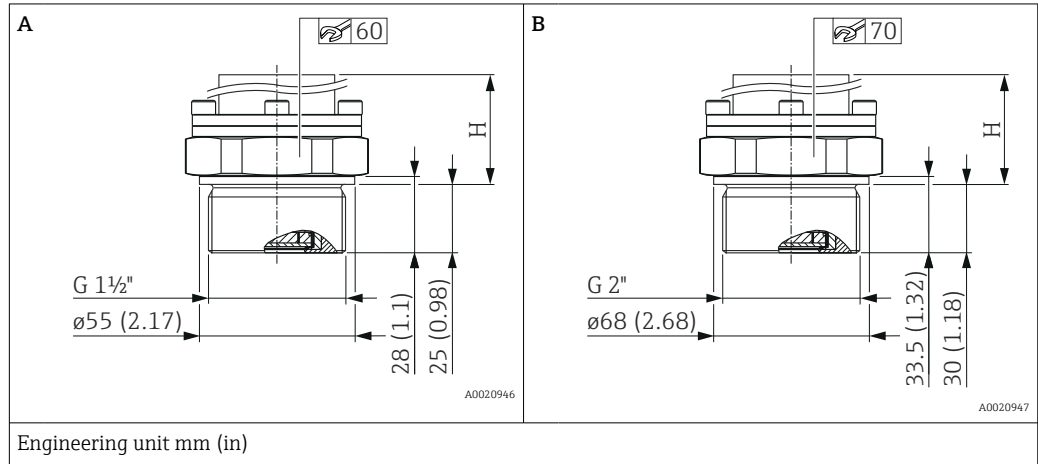

Item	Designation	Material	Weight	Option ¹⁾
			kg (lbs)	
A	ISO 228 G 1 1/2" A thread	AISI 316L	0.63 (1.39)	GVJ
		Alloy C276 (2.4819)		GVC
		Monel (2.4360)		GVD
B	ISO 228 G 2" A thread	AISI 316L	0.63 (1.39)	GWJ
		Alloy C276 (2.4819)		GWC
		Monel (2.4360)		GWD

1) Product Configurator, order code for "Process connection"

Item	Description	Height H
A	Standard version	59 mm (2.32 in)
	High-temperature version	66 mm (2.6 in)
B	Standard version	54 mm (2.13 in)
	High-temperature version	61 mm (2.4 in)

FMD71 hygiene

Hygienic process connections with flush process membrane

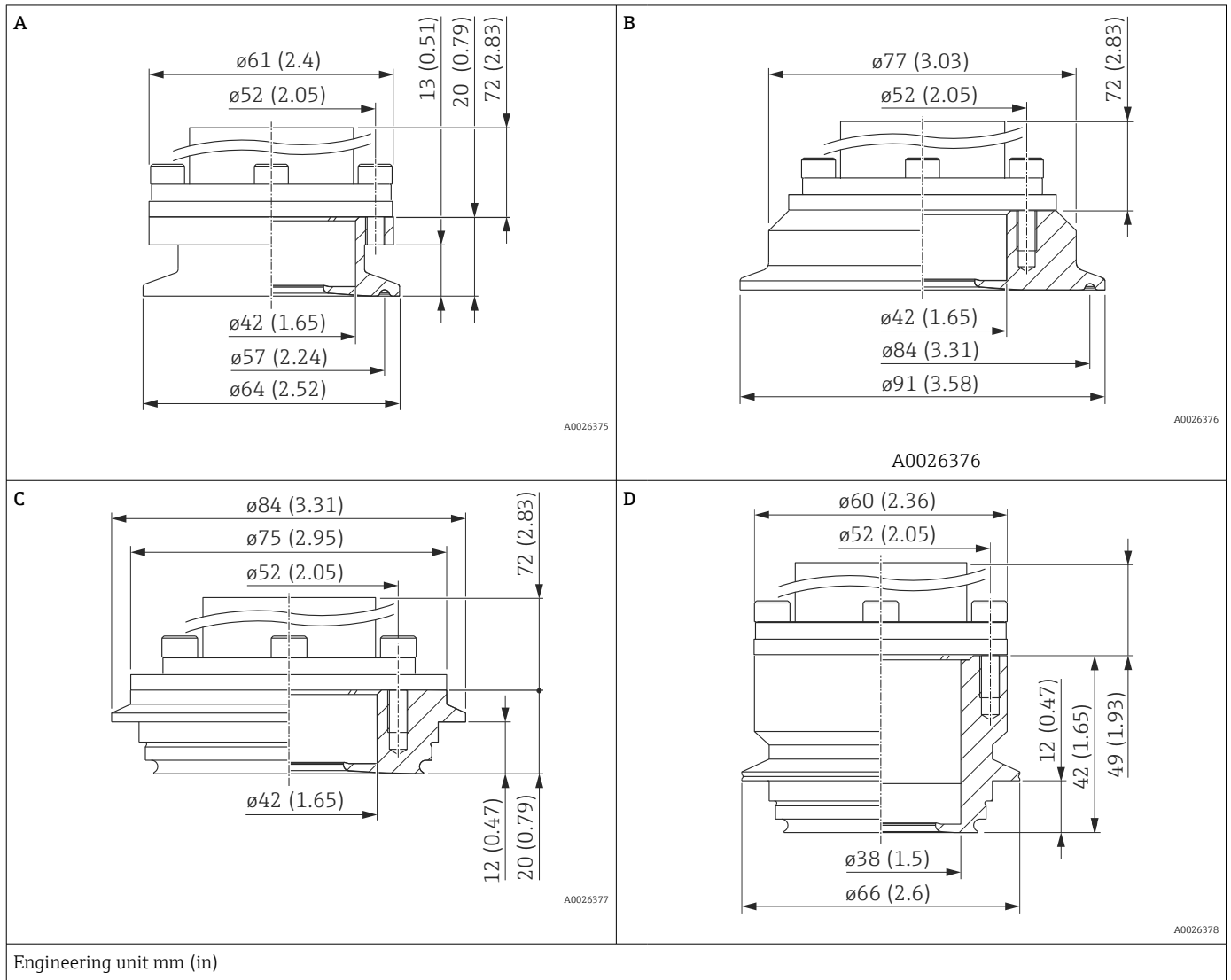

Item	Designation	Material	Weight	Option ¹⁾
			kg (lbs)	
A ²⁾	Tri-Clamp ISO 2852 DN 40 – DN 51 (2"), DIN 32676 DN50, EHEDG, 3A (CRN)	AISI 316L (1.4435)	0.7 (1.54)	TDJ
B	Tri-Clamp ISO 2852 DN76.1 (3"), EHEDG, 3A, with FDA seal		0.9 (1.98)	TFJ
C ²⁾	Varivent Type N for pipes 40 – 162, PN40, EHEDG, 3A (CRN)		1 (2.21)	TRJ
D	Varivent Type F for pipes DN25-32 PN40, 316L, EHEDG, 3A, with FDA seal		0.46 (1)	TQJ

- 1) Product Configurator, oder code for "Process connection"
- 2) Roughness of wetted surfaces $R_a < 0.76 \mu\text{m}$ (30 μin) as standard. Surface quality $R_a < 0.38 \mu\text{m}$ (15 μin) electropolished (wetted) available on request.

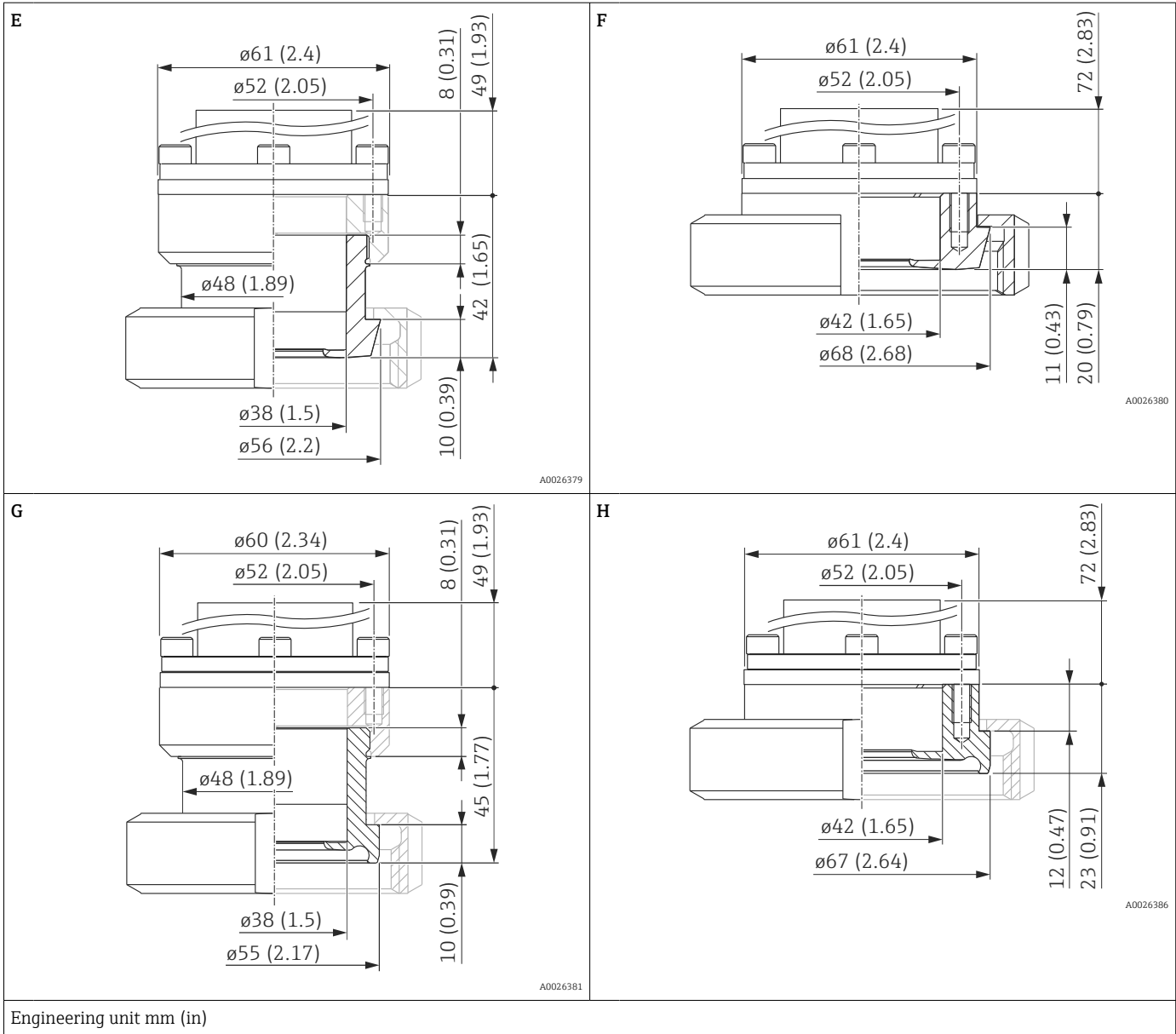

Item	Designation	Material	Weight	Option ¹⁾
			kg (lbs)	
E	DIN 11851 DN40 PN25, EHEDG, 3A (CRN)	AISI 316L (1.4435)	0.7 (1.54)	MZJ ²⁾
F	DIN 11851 DN50 PN25, EHEDG, 3A (CRN)		0.9 (1.98)	MRJ ²⁾
G	DIN 11864-1 A DN40 PN16 pipe DIN11866-A, slotted nut, 316L, EHEDG, 3A		1 (2.21)	NCJ ²⁾
H	DIN 11864-1 A DN50 PN40 pipe DIN11866-A, slotted nut, 316L, EHEDG, 3A		1 (2.21)	NDJ ²⁾

1) Product Configurator, order code for "Process connection"

2) Endress+Hauser supplies these slotted nuts in stainless steel AISI 304 (DIN/EN material number 1.4301) or in AISI 304L (DIN/EN material number 1.4307).

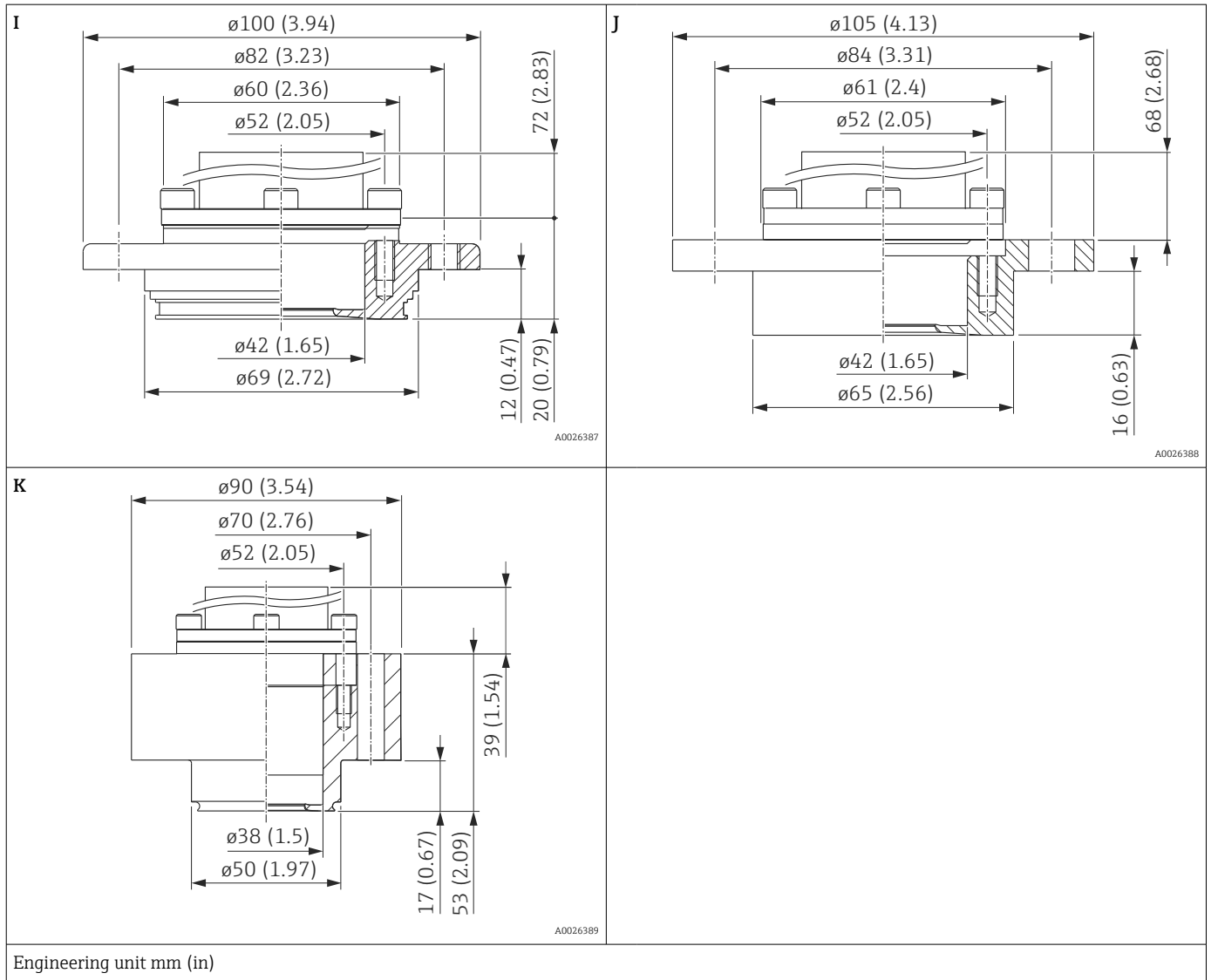

Item	Designation	Material	Weight		Option ¹⁾
			kg	(lbs)	
I	APV inline DN50 PN25, 316L, 3A, with FDA seal	AISI 316L (1.4435)	1.2	(2.65)	TMJ
J	DRD DN50 (65 mm) PN25, slip-on flange AISI 304 (1.4301)		0.9	(1.98)	TIJ
K	NEUMO BioControl, D50, PN16, 316L, 3A		0.8	(1.76)	S4J

1) Product Configurator, order code for "Process connection"

Universal process adapter

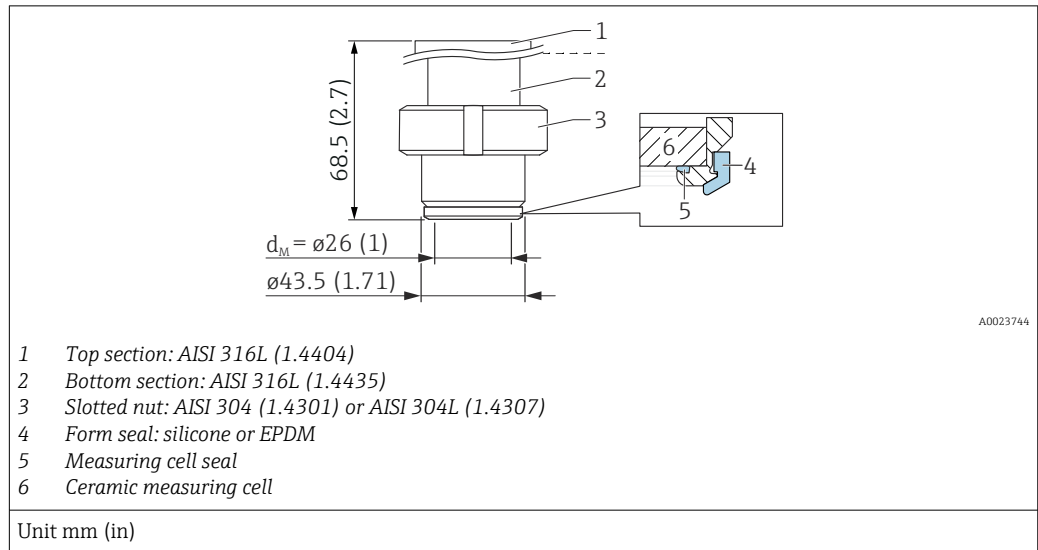

- The roughness of the surface in contact with the medium is $R_a < 0.76 \mu\text{m}$ (30 μin).
- Silicone form seal: FDA 21CFR177.2600/USP Class VI, order number: 52023572
- EPDM form seal: FDA, USP Class VI; 5 pcs, order number: 71100719

Designation	PN bar (psi)	Weight	Option ¹⁾
		[kg (lb)] ²⁾	
Universal process adapter Form seal made of silicone	10 (145)	0.74 (1.63)	UPJ
Universal process adapter Form seal made of EPDM			UNJ

- 1) Product Configurator, order code for "Process connection"
 2) Total weight consisting of the measuring cell assembly and the process connection.

Material of the form seal (exchangeable seal)	Material of the measuring cell seal on ceramic sensor (seal not exchangeable)	Approval of measuring cell seal	Option ¹⁾
Silicone	EPDM	FDA ²⁾ 3A Class II, USP Class VI. DVGW, KTW, W270, WRAS, ACS, NSF61	K
EPDM	EPDM	FDA ²⁾	J
		FDA ²⁾ 3A Class II, USP Class VI. DVGW, KTW, W270, WRAS, ACS, NSF61	K

- 1) Product Configurator, order code for "Seal"
 2) Food-safe FDA 21 CFR 177.2600

Process connections FMD71, EN flanges, connection dimensions in accordance with EN 1092-1
flush process membrane

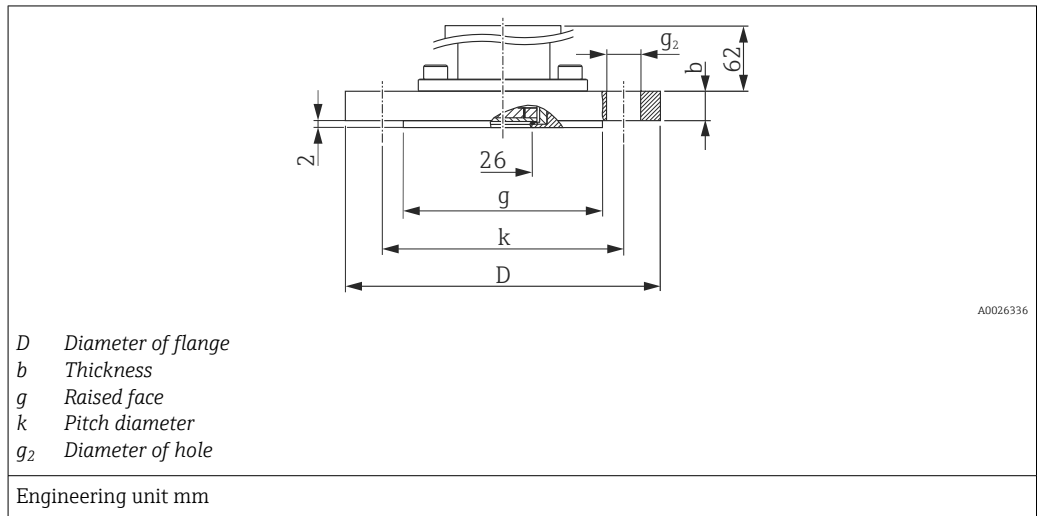

Flange							Boltholes			Weight	Option ¹⁾
DN	PN	Form	Material	D	b	g	Quantity	g ₂	k		
				mm	mm	mm			mm	mm	kg (lbs)
DN 25	PN 10-40	B1	AISI 316L	115	18	68	4	14	85	1.4 (3.09)	CNJ
DN 32	PN 10-40	B1	AISI 316L	140	18	78	4	18	100	2 (4.41)	CPJ
DN 40	PN 10-40	B1	AISI 316L	150	18	88	4	18	110	2.4 (5.29)	CQJ
DN 40	PN 10-40	B1	ECTFE ²⁾	150	21	88	4	18	110	2.6 (5.73)	CQP
DN 50	PN 10-40	B1	AISI 316L	165	20	102	4	18	125	3.2 (7.06)	CXJ
DN 50	PN 10-16	B1	PVDF	165	18	102	4	18	125	2.9 (6.39)	CFF
DN 50	PN 25-40	B1	ECTFE ²⁾	165	20	102	4	18	125	3.2 (7.06)	CRP
DN 50	PN 63 (64)	B2	AISI 316L	180	26	102	4	22	135	4.6 (10.14)	PDJ
DN 80	PN 10-16	B1	PVDF	200	21.4	138	8	18	160	1 (2.21)	CGF
DN 80	PN 10-40	B1	AISI 316L	200	24	138	8	18	160	5.5 (12.13)	CZJ
DN 80	PN 25-40	B1	ECTFE ²⁾	200	24	138	8	18	160	5.5 (12.13)	CSP

1) Product Configurator, order code for "Process connection"
 2) ECTFE coating on AISI 316L (1.4404). When operating in hazardous areas, avoid electrostatic charging of the plastic surfaces.

Process connections FMD71, ASME flanges, connection dimensions as per ASME B 16.5, raised face RF
flush process membrane

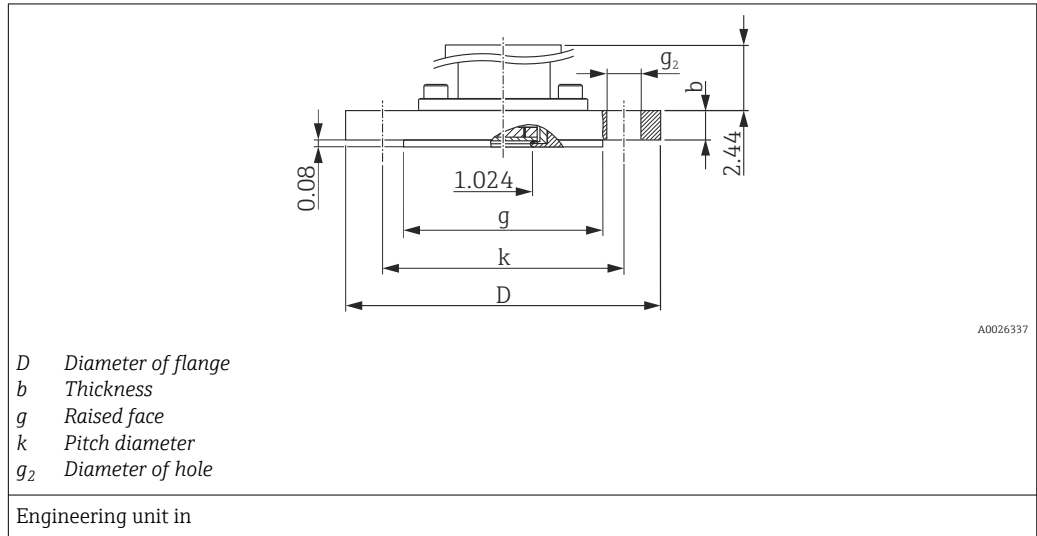

Flange ¹⁾						Boltholes			Weight kg (lbs)	Option ²⁾
NPS in	Class lb./sq.in	Material	D in	b in	g in	Quantity	g ₂ in	k in		
1	150	AISI 316/316L ³⁾	4.25	1.18	2	4	0.62	3.12	0.9 (1.98)	ACJ
1	300	AISI 316/316L ³⁾	4.88	1.18	2	4	0.75	3.5	1.4 (3.09)	ANJ
1 ½	150	AISI 316/316L ³⁾	5	0.69	2.88	4	0.62	3.88	2.1 (4.63)	AEJ
1 ½	300	AISI 316/316L ³⁾	6.12	0.81	2.88	4	0.88	4.5	2.6 (5.73)	AQJ
2	150	AISI 316/316L ³⁾	6	0.75	3.62	4	0.75	4.75	3.0 (6.62)	AFJ
2	150	ECTFE ⁴⁾	6	0.75	3.62	4	0.75	4.75	2.4 (5.29)	AFN
2	150	PVDF	6	0.75	3.62	4	0.75	4.75	0.5 (1.10)	AFF
2	300	AISI 316/316L ³⁾	6.5	0.88	3.62	8	0.75	5	3.2 (7.06)	ARJ
3	150	AISI 316/316L ³⁾	7.5	0.94	5	4	0.75	6	5.7 (12.57)	AGJ
3	150	ECTFE ⁴⁾	7.5	0.94	5	4	0.75	6	4.9 (10.80)	AGN
3	150	PVDF	7.5	0.94	5	4	0.75	6	0.9 (1.98)	AGF
3	300	AISI 316/316L ³⁾	8.25	1.12	5	8	0.88	6.62	6.8 (14.99)	ASJ
4	150	AISI 316/316L ³⁾	9	0.94	6.19	8	0.75	7.5	7.8 (17.2)	AHJ
4	150	ECTFE ⁴⁾	9	0.94	6.19	8	0.75	7.5	7.1 (15.66)	AHN
4	300	AISI 316/316L ³⁾	10	1.25	6.19	8	0.88	7.88	11.6 (25.58)	ATJ

1) AISI 316L
 2) Product Configurator, order code for "Process connection"
 3) Combination of AISI 316 for required pressure resistance and AISI 316L for required chemical resistance (dual rated)
 4) ECTFE coating on AISI 316/316L. When operating in hazardous areas, avoid electrostatic charging of the plastic surfaces.

Process connections FMD71, flush process membrane JIS flanges, connection dimensions as per JIS B 2220 BL, raised face RF

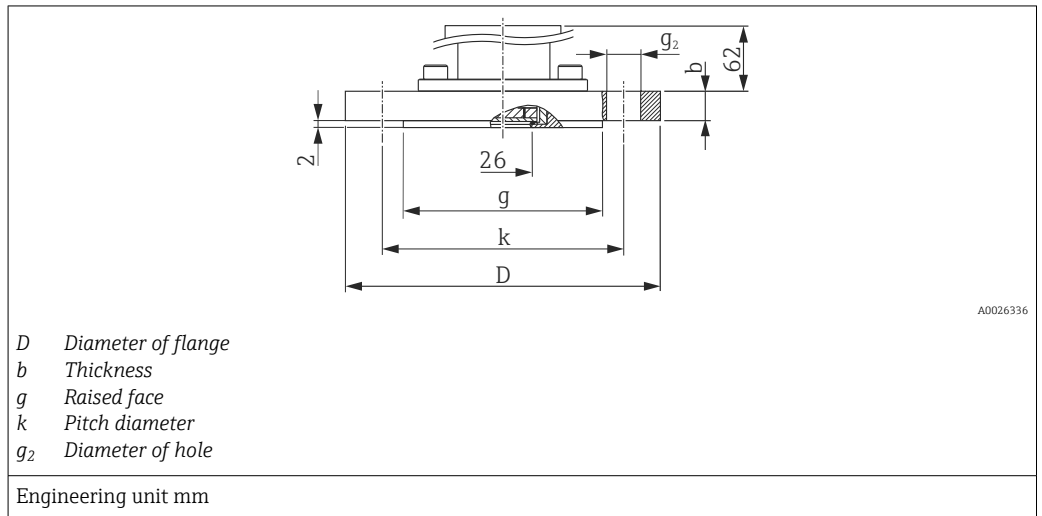

Flange ^{1) 2)}					Boltholes			Weight	Option ³⁾
A	K	D	b	g	Quantity	g ₂	k		
		mm	mm	mm		mm	mm	kg (lbs)	
50 A	10 K	155	16	96	4	19	120	2.0 (4.41)	KFJ
80 A	10 K	185	18	127	8	19	150	3.3 (7.28)	KGJ
100 A	10 K	210	18	151	8	19	175	4.4 (9.7)	KHJ

- 1) AISI 316L (1.4435)
- 2) The roughness of the surface in contact with the medium including the raised face of the flanges is Ra 0.8 µm (31.5 µin). Lower surface roughness available on request.
- 3) Product Configurator, order code for "Process connection"

Process connections FMD72, ISO 228 G thread
internal process membrane

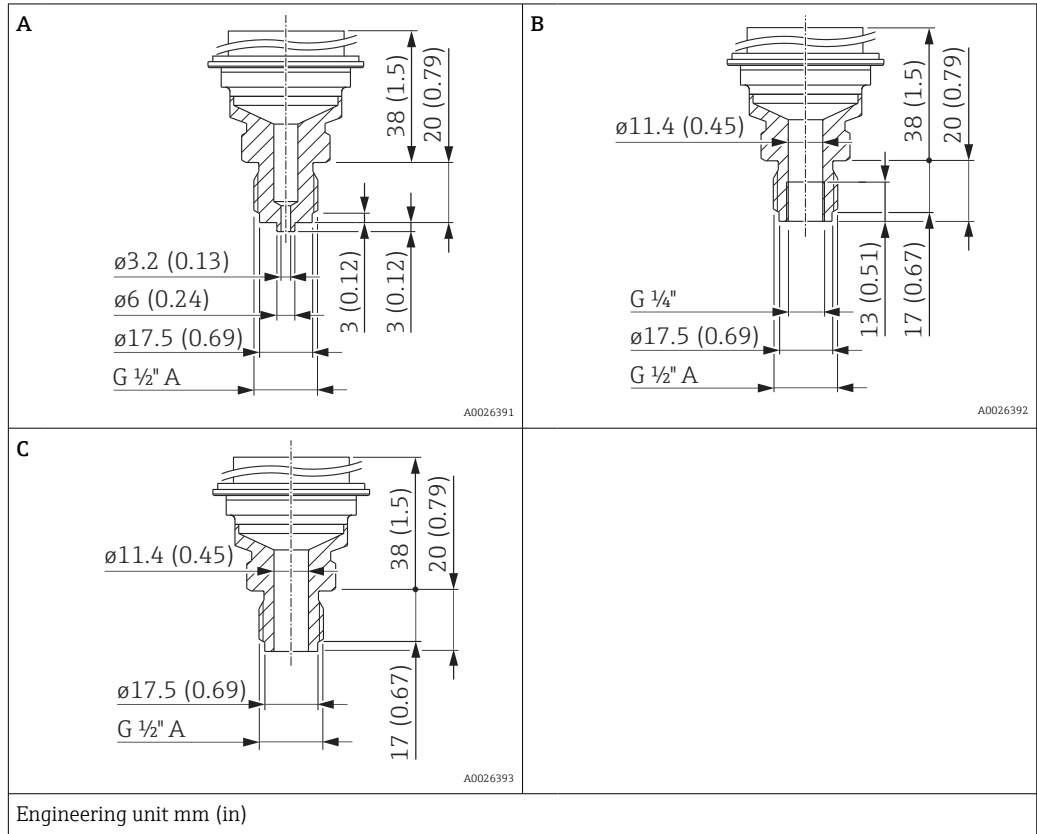

Item	Designation	Material	Weight	Option ¹⁾
			kg (lbs)	
A	ISO 228 G 1/2" A EN 837 thread	AISI 316L	0.63 (1.39)	GCJ
		Alloy C276 (2.4819)		GCC
B	ISO 228 G 1/2" A thread, G 1/4" (female) EN 837	AISI 316L	0.63 (1.39)	GLJ
		Alloy C276 (2.4819)		GLC
C	ISO 228 G 1/2" A EN 837 thread, bore 11.4 mm (0.45 in)	AISI 316L	0.63 (1.39)	GMJ
		Alloy C276 (2.4819)		GMC

1) Product Configurator, order code for "Process connection"

Process connections FMD72, internal process membrane **ANSI thread**

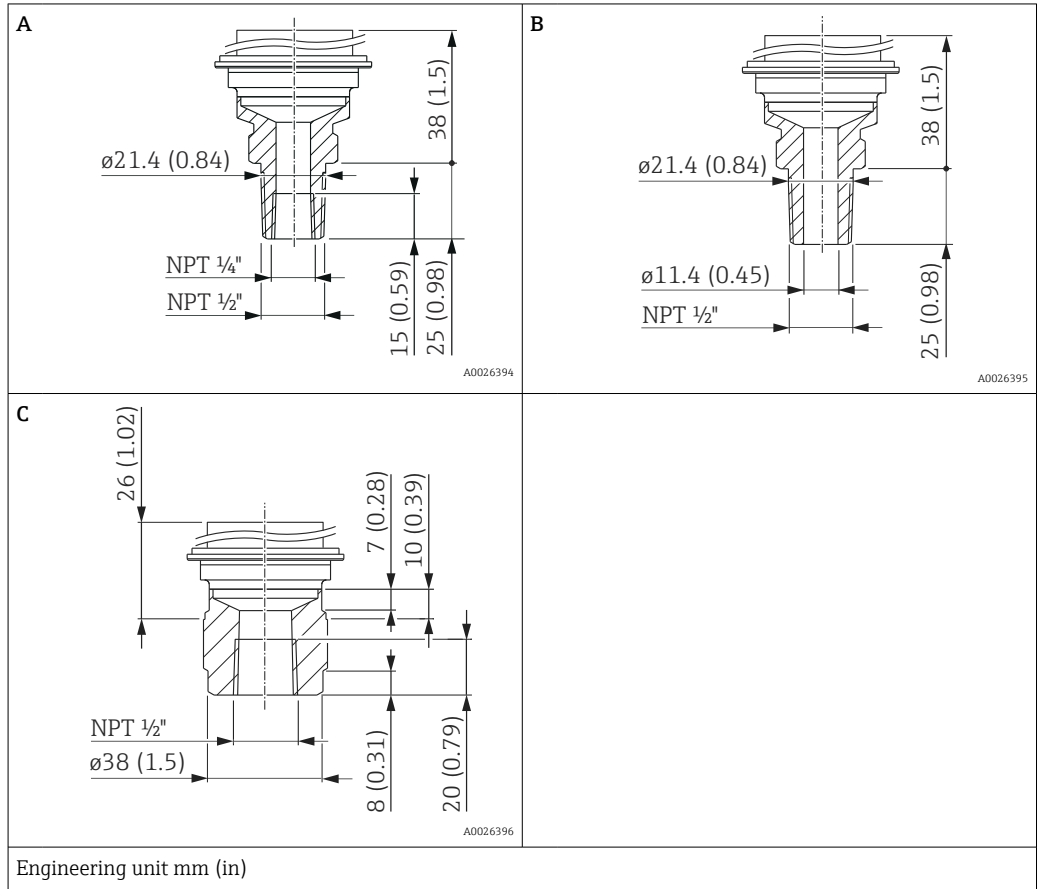

Item	Designation	Material	Weight		Option ¹⁾
			kg	(lbs)	
A	ANSI 1/2" MNPT, 1/4" FNPT	AISI 316L (CRN)	0.63	(1.39)	RLJ
		Alloy C276 (2.4819) (CRN)			RLC
B	ANSI 1/2" MNPT, bore 11.4 mm (0.45 in)	AISI 316L (CRN)			RKJ
		Alloy C276 (2.4819) (CRN)			RKC
D	ANSI 1/2" FNPT 11.4 mm (0.45 in)	AISI 316L (CRN)	R1J		
		Alloy C276 (2.4819) (CRN)	R1C		

1) Product Configurator, order code for "Process connection"

Process connections FMD72,
flush process membrane ISO 228 G thread

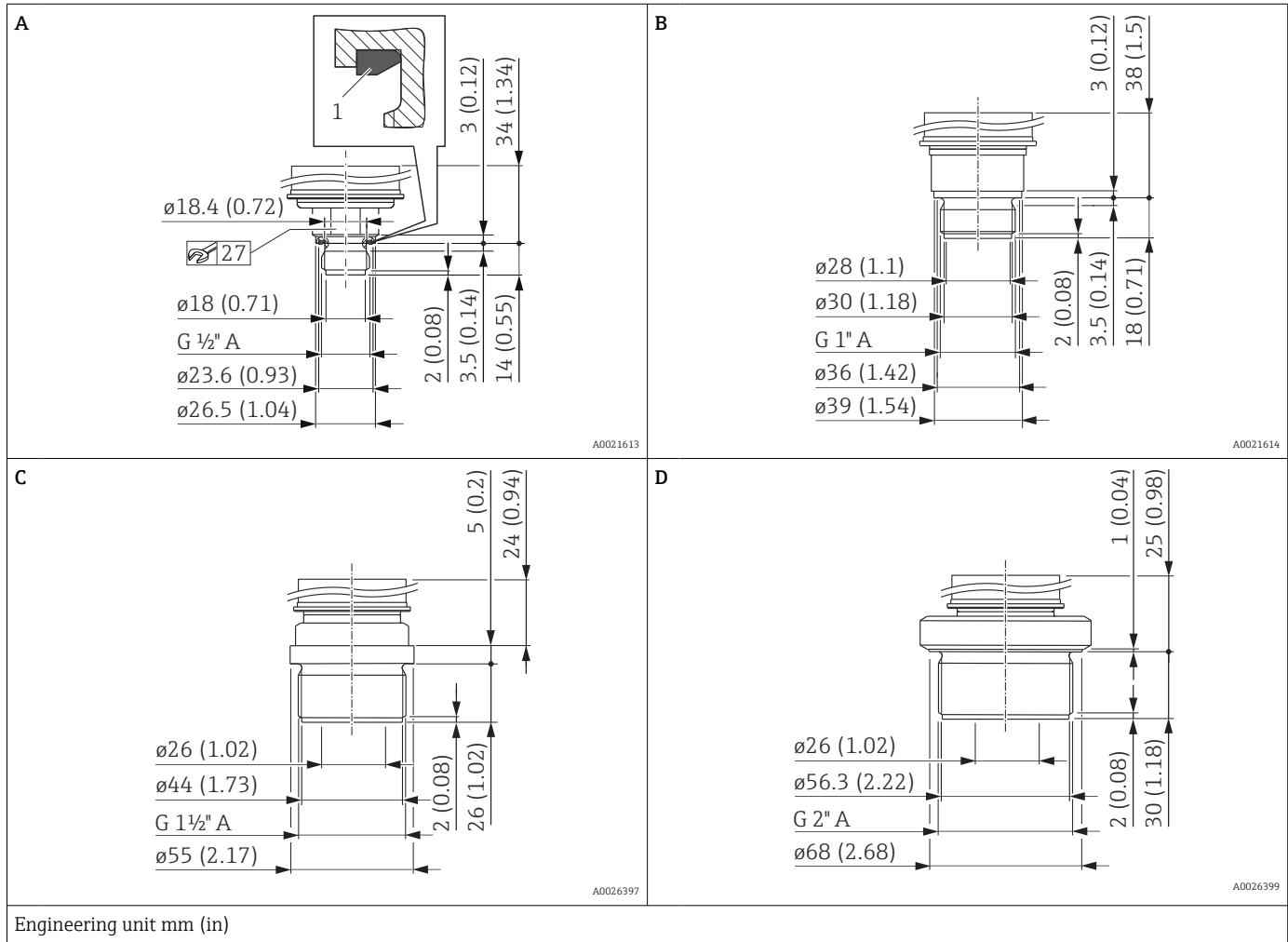

Item	Designation	Material	Weight		Option ¹⁾
			kg	(lbs)	
A	ISO 228 G 1/2" A thread, DIN 3852 FKM form seal (item 1) pre-installed	AISI 316L	0.4	(0.88)	GRJ
B	ISO 228 G 1" A thread	AISI 316L	0.7	(1.54)	GTJ
C	ISO 228 G 1 1/2" A thread	AISI 316L	1.1	(2.43)	GVJ
D	ISO 228 G 2" A thread	AISI 316L	1.5	(3.31)	GWJ

1) Product Configurator, order code for "Process connection"

Process connections FMD72, ANSI thread
flush process membrane

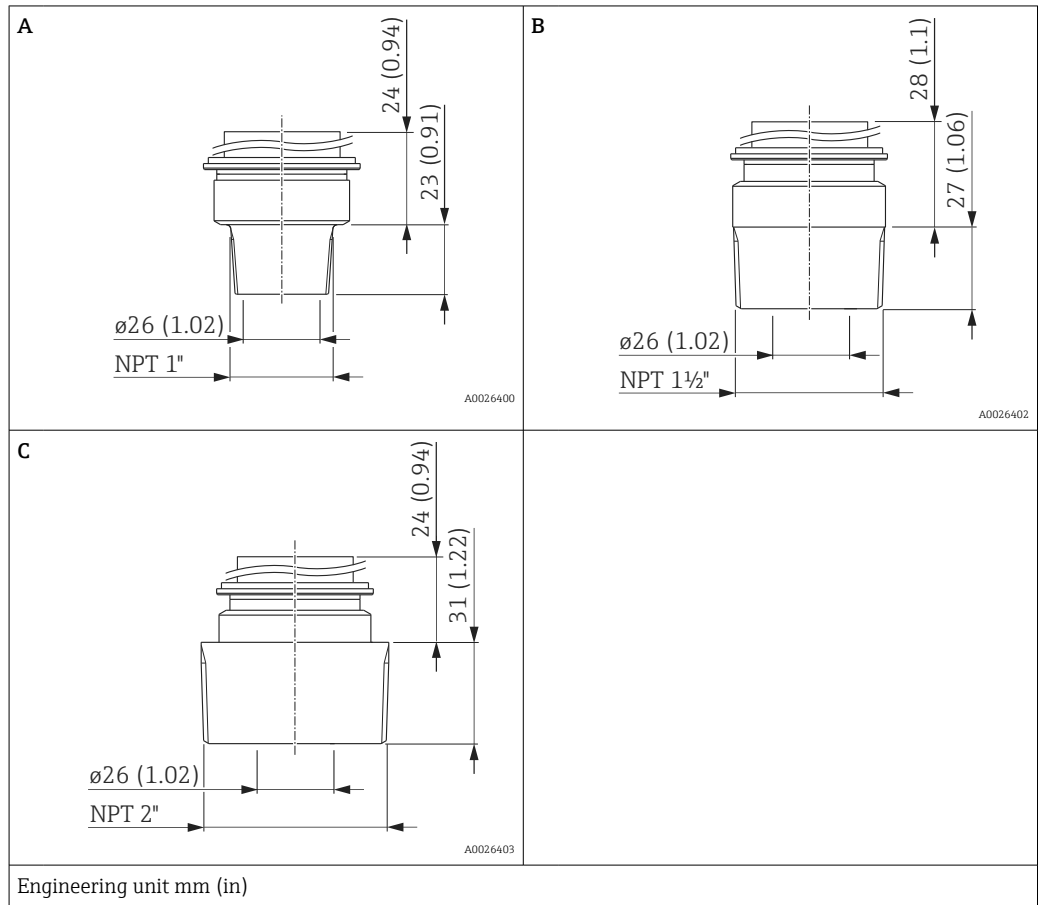

Item	Designation	Material	Weight	Option ¹⁾
			kg (lbs)	
A	ANSI 1" MNPT	AISI 316L (CRN)	0.7 (1.54)	U5J
B	ANSI 1 ½" MNPT	AISI 316L (CRN)	1 (2.21)	U7J
C	ANSI 2" MNPT	AISI 316L (CRN)	1.3 (2.87)	U8J

1) Product Configurator, order code for "Process connection"

Process connections FMD72,
flush process membrane

EN flanges, connection dimensions in accordance with EN 1092-1

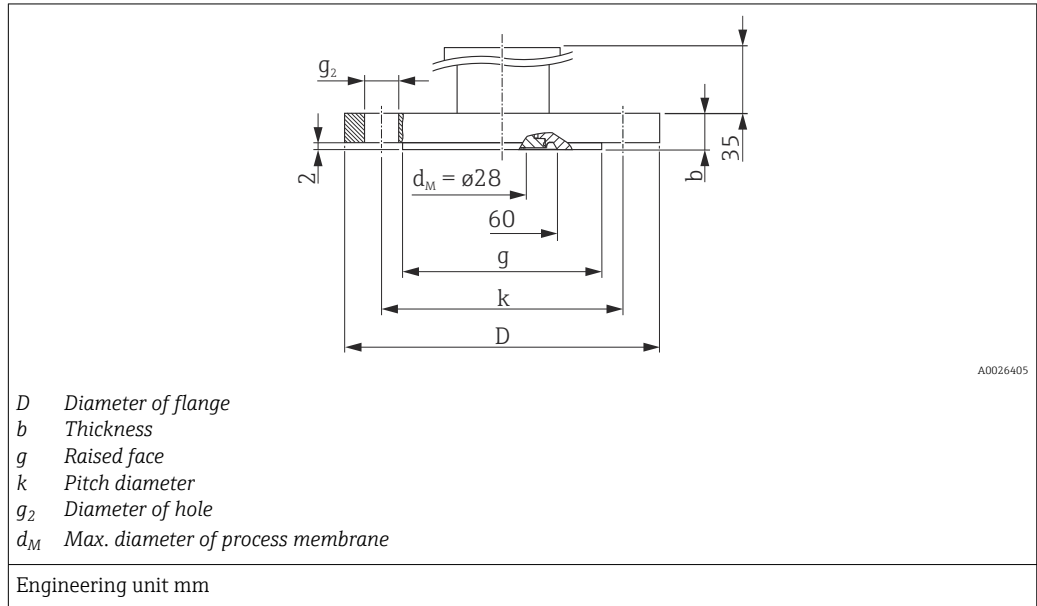

Flange ^{1) 2)}							Boltholes			Option ³⁾
DN	PN	Form	D	b	g	Weight	Quantity	g ₂	k	
			[mm]	[mm]	[mm]	[kg (lbs)]		[mm]	[mm]	
DN 25	PN 10-40	B1	115	18	68 ⁴⁾	1.2 (2.65)	4	14	85	CNJ
DN 32	PN 10-40	B1	140	18	78 ⁴⁾	1.9 (4.19)	4	18	100	CPJ
DN 40	PN 10-40	B1	150	18	88 ⁴⁾	2.2 (4.85)	4	18	110	CQJ
DN 50	PN 10-40	B1	165	20	102	3.0 (6.62)	4	18	125	CXJ
DN 80	PN 10-40	B1	200	24	138	5.3 (11.69)	8	18	160	CZJ

- 1) The roughness of the surface in contact with the medium including the raised face of the flanges (all standards) is $R_a 0.8 \mu m (31.5 \mu in)$. Lower surface roughness on request.
- 2) AISI 316L
- 3) Product Configurator, order code for "Process connection"
- 4) The sealing surface in these process connections is smaller than what is specified in the standard. Due to the smaller sealing surface, a special seal must be used. In this case, contact a seal manufacturer or Endress+Hauser sales office.

Process connections FMD72, ASME flanges, connection dimensions as per ASME B 16.5, raised face RF
flush process membrane

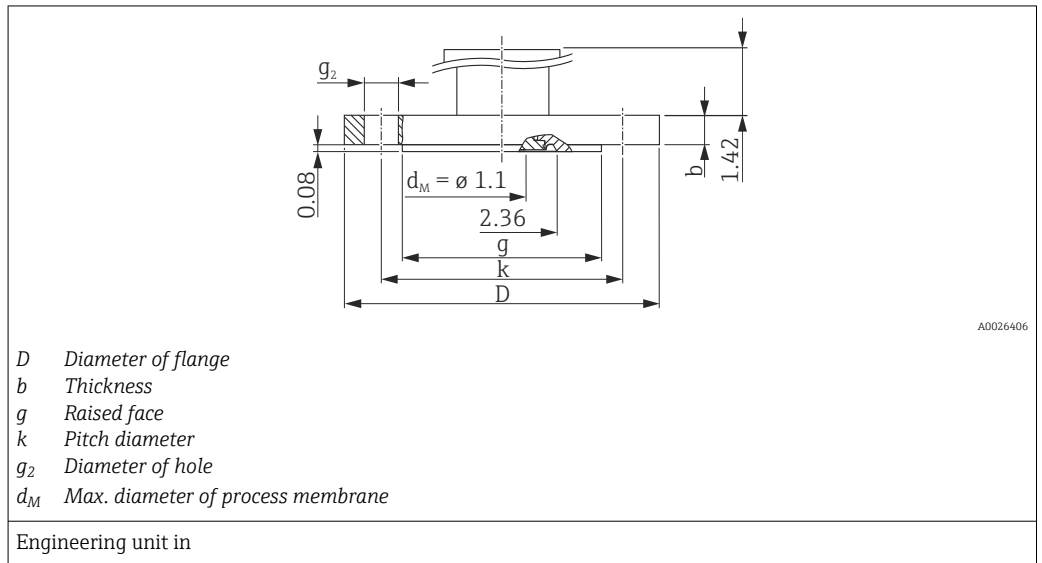

Flange ^{1) 2)}						Boltholes			Option ³⁾
NPS (nominal diameter of pipe)	Class	D	b	g	Weight	Quantity	g ₂	k	
[in]	lb./sq.in	[in]	[in]	[in]	[kg (lbs)]		[in]	[in]	
1	150	4.25	0.61	2.44	1.1 (2.43)	4	0.62	3.13	ACJ ⁴⁾
1	300	4.88	0.69	2.70	1.3 (2.87)	4	0.75	3.5	ANJ
1 ½	150	5	0.69	2.88	1.5 (3.31)	4	0.62	3.88	AEJ
1 ½	300	6.12	0.81	2.88	2.6 (5.73)	4	0.88	4.5	AQJ
2	150	6	0.75	3.62	2.4 (5.29)	4	0.75	4.75	AFJ
2	300	7.5	0.88	3.62	3.2 (7.06)	8	0.75	5	ARJ
3	150	7.5	0.94	5	4.9 (10.80)	4	0.75	6	AGJ
3	300	8.25	1.12	5	6.7 (14.77)	8	0.88	6.62	ASJ
4	150	9	0.94	6.19	7.1 (15.66)	8	0.75	7.5	AHJ
4	300	10	1.25	6.19	11.6 (25.88)	8	0.88	7.88	ATJ

- 1) The roughness of the surface in contact with the medium is $R_a 0.8 \mu m (31.5 \mu in)$. Lower surface roughness on request.
- 2) Material AISI 316/316L (combination of AISI 316 for required pressure resistance and AISI 316L for required chemical resistance (dual rated))
- 3) Product Configurator, order code for "Process connection"
- 4) Screws must be 15 mm (0.59 in) longer than the standard flange screws.

FMD72 hygiene

Hygienic process connections with flush process membrane

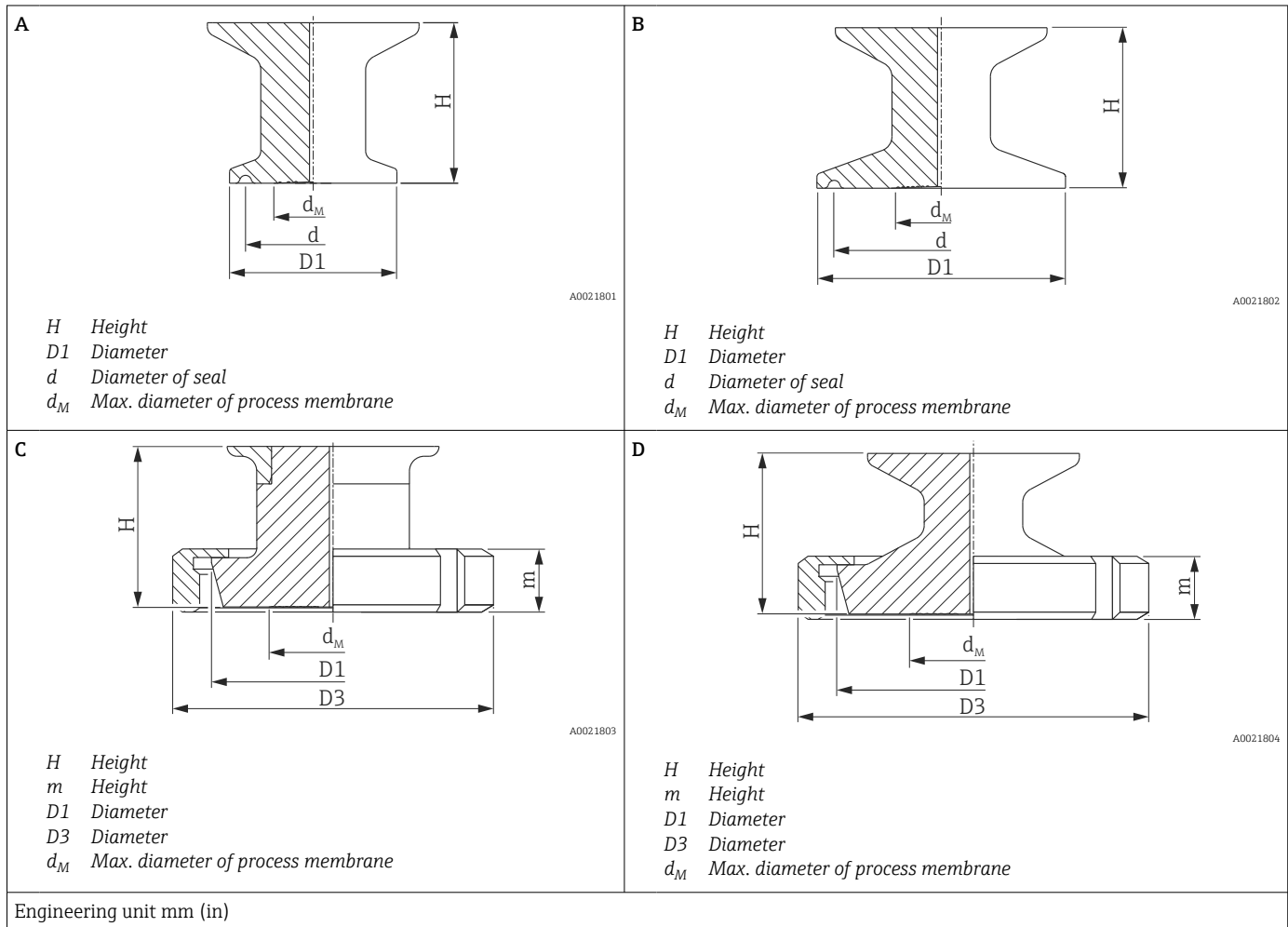

Item	Designation	PN	D1	D3	d	d _M	H	m	Material	Weight		Option ¹⁾
										kg	(lbs)	
A	Clamp DN18-22, 3A	40	34 (1.34)	-	27.5 (1.08)	17.2 (0.68)	max. 40 (1.57)	-	AISI 316L (1.4435)	0.5 (1.10)	TBJ	
B	Clamp 1", 3A	40	50.5 (1.99)	-	43.5 (1.71)	21.65 (0.85)		-		0.6 (1.32)	TCJ ²⁾	
	Clamp 1½", 3A	40	50.5 (1.99)	-	43.5 (1.71)	28 (1.10)		-		0.6 (1.32)	²⁾ TJJ	
	Clamp 2", 3A	40	64 (2.52)	-	56.5 (2.22)	28 (1.10)		-		0.7 (1.54)	TDJ ²⁾	
C	DIN11851 B25	40	43.4 (1.71)	63 (2.48)	-	28 (1.10)		21 (0.83)		0.7 (1.54)	MXJ	
	DIN11851 B32, 3A	40	49.4 (1.94)	70 (2.76)	-	28 (1.10)		21 (0.83)		0.8 (1.76)	MIJ	
D	DIN11851 B40, 3A	40	55.4 (2.18)	78 (3.07)	-	28 (1.10)		21 (0.83)		0.9 (1.98)	MZJ	
	DIN11851 B50, 3A	40	67.4 (2.65)	92 (3.62)	-	28 (1.10)		22 (0.87)		1.1 (2.43)	MRJ	

1) The roughness of the surface in contact with the medium is R_a < 0.76 µm (30 µin).
 2) With CRN approval

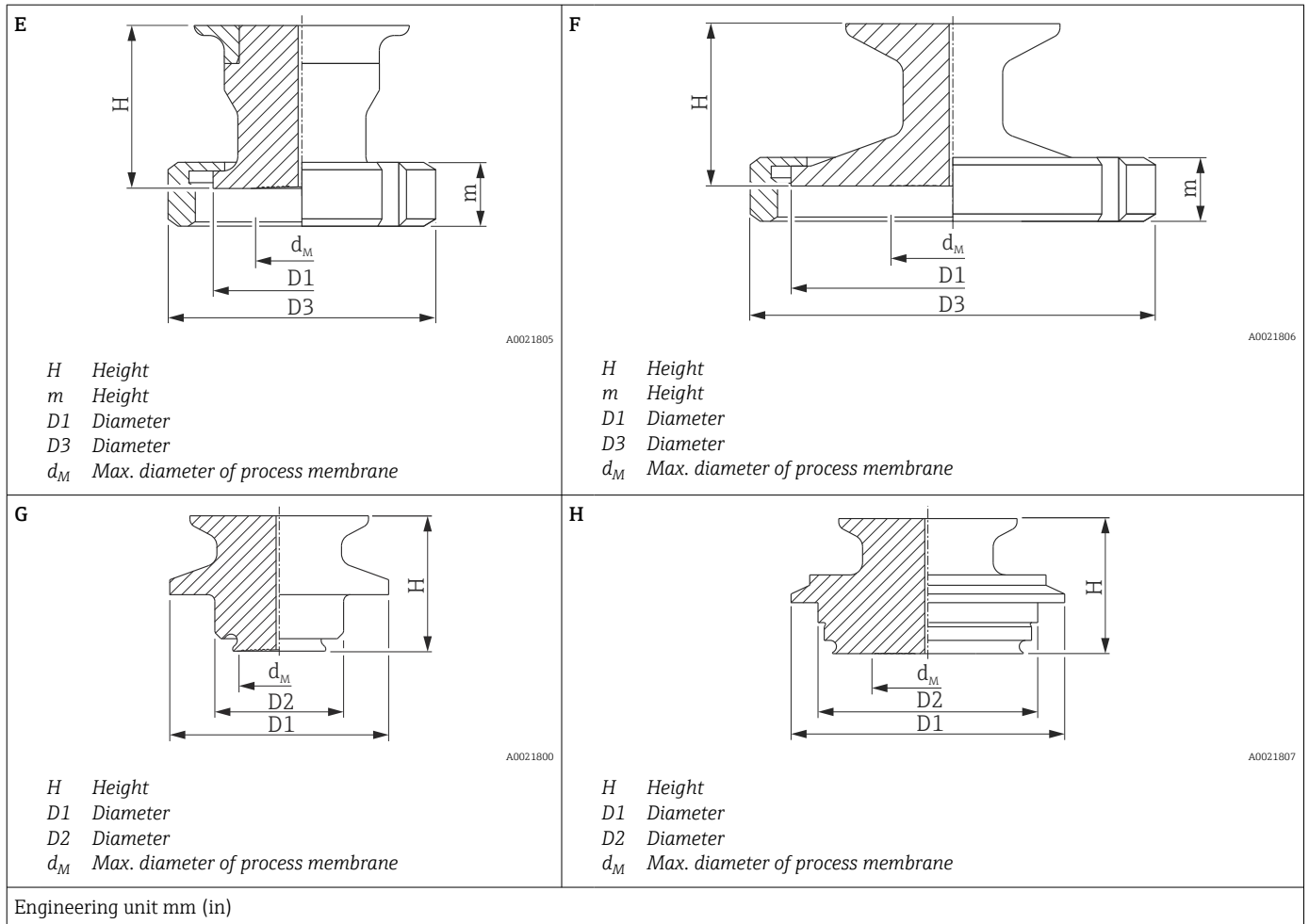

Item	Designation	PN	D1	D2	D3	d _M	H	m	Material	Weight		Option ¹⁾
										kg	(lbs)	
E	SMS 1", 3A	25	35.5 (1.4)	-	51 (2.01)	21.65 (0.85)	max. 40 (1.57)	20 (0.79)	AISI 316L (1.4435)	0.7 (1.54)	T6J	
F	SMS 1½", 3A	25	55 (2.17)	-	74 (2.91)	28 (1.10)		25 (0.98)		0.8 (1.76)	T7J	
	SMS 2", 3A	25	65 (2.56)	-	84 (3.31)	28 (1.10)		26 (1.02)		0.9 (1.98)	TXJ	
G	Varivent B, 3A	40	52.7 (2.07)	31 (1.22)	-	21.65 (0.85)		-		0.7 (1.54)	TPJ	
H	Varivent F, 3A	40	66 (2.6)	53 (2.09)	-	28 (1.10)		-		0.9 (1.98)	TQJ	
	Varivent N, 3A	40	84 (3.31)	71 (2.8)	-	28 (1.10)		-		1.1 (2.43)	TRJ	

1) The roughness of the surface in contact with the medium is $R_a < 0.76 \mu\text{m}$ (30 μin).

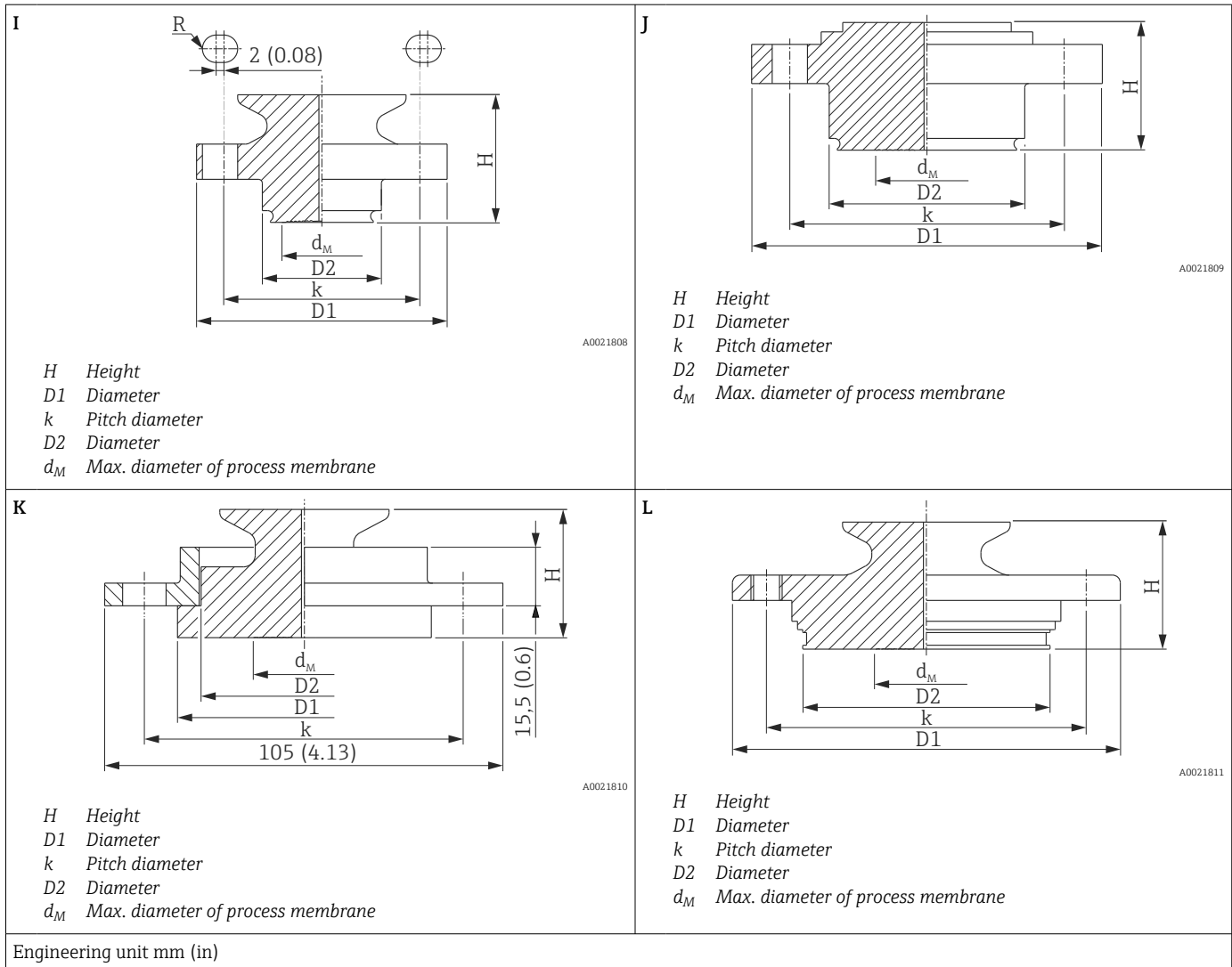

Item	Designation	PN	D1	D2	k	d _M	H	Material	Weight		Option ¹⁾
									kg	(lbs)	
I	Neumo D25, 3A	16	64 (2.52)	30.4 (1.2)	50 (1.97); 4 x, R 3.5 mm (0.14 in)	21.65 (0.85)	max. 40 (1.57)	AISI 316L (1.4435)	0.8 (1.76)	S1J	
J	Neumo D50, 3A	16	89.5 (3.52)	49.9 (1.96)	70 (2.76); 4 x ø 9 mm (0.35 in)	28 (1.10)			1.2 (2.65)	S4J	
K	DRD	25	64.5 (2.54)	52.5 (2.07)	84 (3.31); 4 x ø 11.5 mm (0.45 in)	28 (1.10)			1.0 (2.21)	T1J	
L	APV Inline	25	99.5 (3.92)	64 (2.52)	82 (3.23); 6 x ø 8.6 mm (0.34 in) + 2 x M8	28 (1.10)			1.2 (2.65)	TMJ	

1) The roughness of the surface in contact with the medium is R_a < 0.76 µm (30 µin).

Wall and pipe mounting with mounting bracket

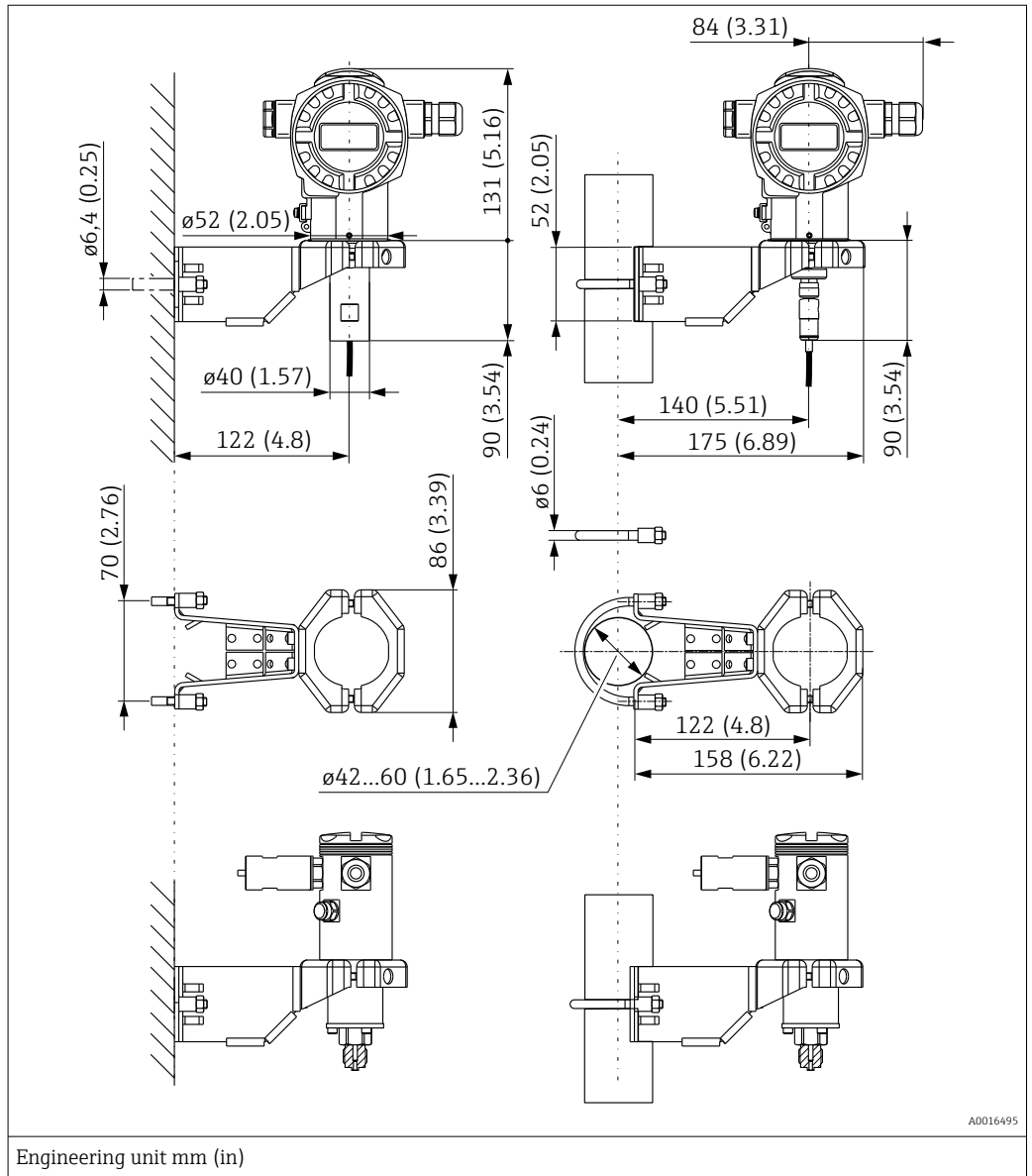

Weight kg (lbs)		Option ¹⁾
Housing	Mounting bracket	
→ 31	0.5 (1.1)	PA

1) Product Configurator, order code for "Process connection"

Also available for order as a separate accessory: part number 71102216

Materials in contact with process**NOTICE**

- ▶ Device components in contact with the process are listed in the "Mechanical construction" →  30 and "Ordering information" sections.

Delta ferrite content

A delta ferrite content of $\leq 3\%$ can be guaranteed and certified for the wetted parts if option "KF" is selected in the "Test, Certificate" order code in the Product Configurator. If the FMD72 with hygienic process connections is selected, a delta ferrite content of $\leq 1\%$ can be guaranteed and certified if option "KF" was selected in the "Test, Certificate" order code in the Product Configurator.

TSE Certificate of Suitability

The following applies to all device components in contact with the process:

- They do not contain any materials derived from animals.
- No additives or operating materials derived from animals are used in production or processing.

Process connections

- Endress+Hauser supplies DIN/EN flanges and threaded connection in stainless steel as per AISI 316L (DIN/ EN material number 1.4404 or 1.4435). With regard to their stability-temperature property, the materials 1.4404 and 1.4435 are grouped together under 13E0 in EN 1092-1: 2001 Tab. 18: The chemical composition of the two materials can be identical.
- "Clamp connections" and "Hygienic process connections": AISI 316L (DIN/EN material number 1.4435)
- Some process connections are also available in Alloy C276 (DIN/EN material number 2.4819). For this purpose see the information in the "Mechanical construction" section.

Process membrane

Sensor	Designation	Option ¹⁾
FMD71	Al ₂ O ₃ aluminum oxide ceramic FDA ²⁾ , Ceraphire® (see also www.endress.com/ceraphire)	-
FMD72	AISI 316L (DIN/EN material number 1.4435)	A
FMD72	Alloy C (on request)	B

- 1) Product Configurator, order code for "Process connection"
- 2) The US Food & Drug Administration (FDA) has no objections to the use of ceramics made from aluminum oxide as a surface material in contact with foodstuffs. This declaration is based on supporting documents from the FDA furnished by our ceramic suppliers.

Materials not in contact with process T14 transmitter housing

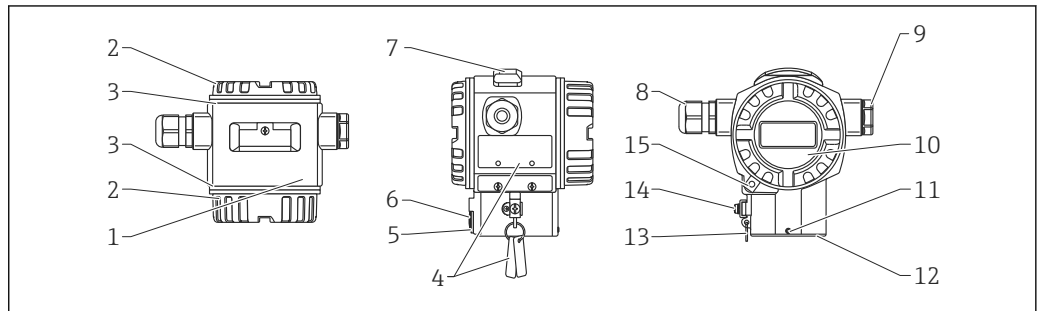

A0016496

Item number	Component	Material
1	T14 housing, RAL 5012 (blue)	Die-cast aluminum with protective powder-coating on polyester base
	T14 housing	Precision cast AISI 316L (1.4435)
2	Cover, RAL 7035 (gray)	<ul style="list-style-type: none"> ▪ Die-cast aluminum with protective powder-coating on polyester base ▪ Coating on thread: Heat-curing lubricant varnish
	Cover	<ul style="list-style-type: none"> ▪ Precision cast AISI 316L (1.4435) ▪ Coating on thread: Heat-curing lubricant varnish
3	Cover seal	EPDM
4	Nameplates	AISI 304 (1.4404)
5	Pressure compensation filter, O-ring	VMQ or EPDM
6	Pressure compensation filter	AISI 316L (1.4404) and PBT-FR
7	External operation (keys and key cover), RAL 7035 (gray)	Polycarbonate PC-FR, screw A4
8	Cable entry	Polyamide (PA)
	Seal	Silicone (VMQ)
9	Plug	PBT-GF30 FR, for dust ignition-proof: AISI 316L (1.4435)
	Seal	Silicone (VMQ)
10	Sight glass	Mineral glass (polycarbonate on request)
	Sight glass seal	Silicone (VMQ)
11	Screw	A4
12	Sealing ring	EPDM
	Snap ring	PA66-GF25
13	Round strand rope for nameplates	AISI 304 (1.4301) / AISI 316 (1.4401)
14	External ground terminal	AISI 304 (1.4301)
15	Cover clamp	AISI 316L (1.4435) clamp, A4 screw

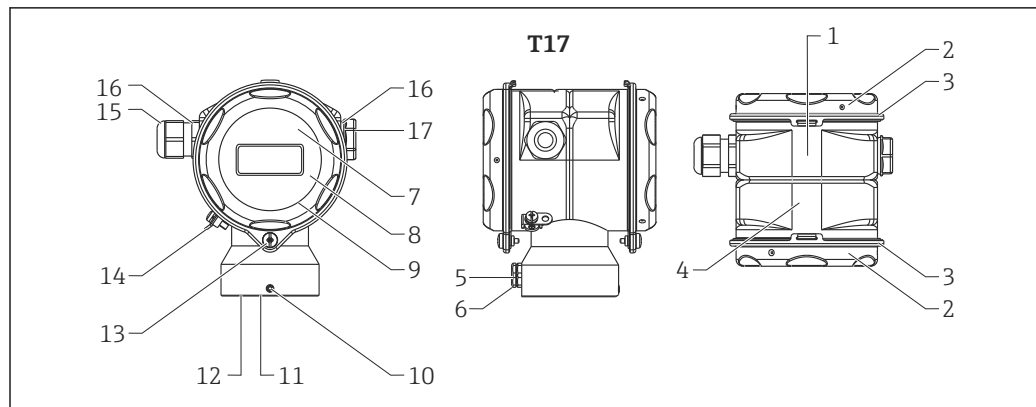
T17 transmitter housing

A0020021

Item number	Component	Material
1	T17 housing	AISI 316L (1.4404)
	Cover	
3	Cover seal	EPDM
4	Nameplates	Lasered on
5	Pressure compensation filter	AISI 316L (1.4404) and PBT-FR
6	Pressure compensation filter, O-ring	VMQ or EPDM
7	Sight glass for non-hazardous area, ATEX Ex ia, NEPSI Zone 0/1 Ex ia, IECEx Zone 0/1 Ex ia, FM NI, FM IS, CSA IS	Polycarbonate (PC)
8		
9	Sight glass seal	EPDM
10	Screw	A2-70
11	Sealing ring	EPDM
12	Snap ring	PA6
13	Screw	A4-50 Coating on thread: Heat-curing lubricant varnish
14	External ground terminal	AISI 304 (1.4301)
15	Cable entry M20	Polyamide PA, for dust ignition-proof: CuZn nickel-plated
16	Seal of cable entry and plug	Silicone (VMQ)
17	Plug	PBT-GF30 FR, for dust ignition-proof: AISI 316L (1.4435)

Sensor modules

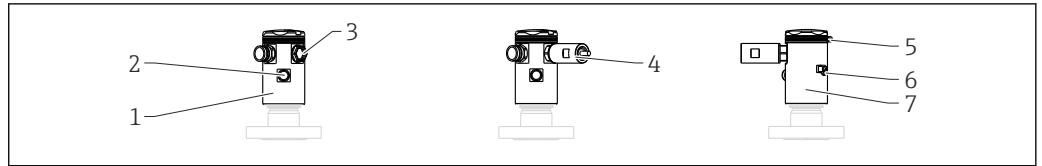

A0021295

Item number	Component	Material
1	Sensor module housing and cover	Aluminum with protective powder-coating on polyester base AISI 316L (1.4404)
2	Pressure compensation filter	PA6 GF10 or 316L (1.4404)
3	Plug	PBT-GF30 FR, for dust ignition-proof: AISI 316L (1.4435)
	Seal	Silicone (VMQ)
4	Conduit adapter NPT ½"	316L
5	Snap ring for cover	PP
6	Earth connection box	316L
7	Nameplates	Plastic film

Connecting parts

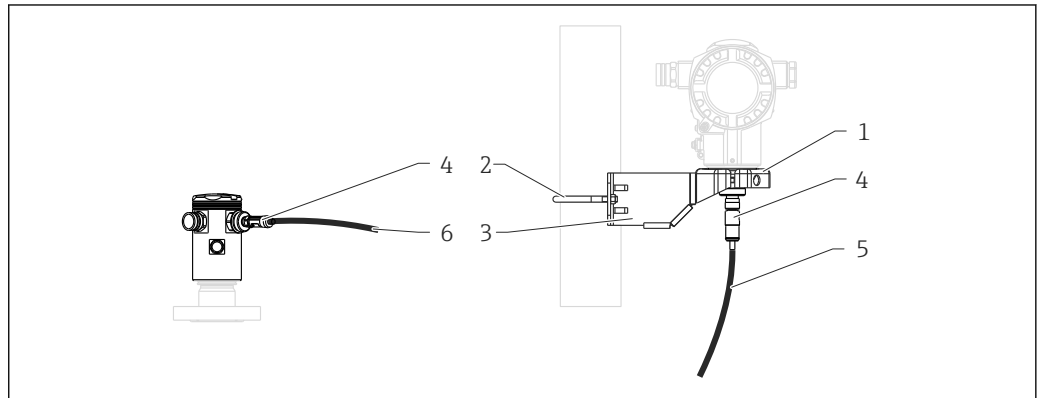

A0016497

Item number	Component	Material
1	Mounting bracket	Bracket AISI 316L (1.4404)
2		Screw and nuts A4-70
3		Half-shells: AISI 316L (1.4404)
4	M12 plug	PP and stainless steel
5	Cable for transmitter connection	PE-X halogen-free
6	Cable for sensor connection	PE-X halogen-free

Fill fluid

Designation	Option ¹⁾
Silicone oil	1
Inert oil (on request)	2
Synthetic oil, FDA	3

1) Product Configurator, order code for "Process connection"

Operability

Operation concept

Operator-oriented menu structure for user-specific tasks

- Commissioning
- Software operation
- Diagnostics
- Expert level

Quick and safe commissioning

Guided menus for applications

Reliable operation

- Local operation possible in up to two languages
- Standardized operation at the device and in the operating tools
- Parameters relating to measured values can be locked/unlocked using the device's write protection switch, using the device software or via remote operation

Efficient diagnostic behavior increases measurement availability

- Remedial measures are integrated in plain text
- Diverse simulation options

Local operation

Functions

Function	External operation (operating keys, optional)	Internal operation (electronic insert)	Onsite display (optional)
Position adjustment (zero point correction)	✓	✓	✓
Setting lower range value and upper range value - reference pressure present at the device	✓	✓	✓
Device reset	✓	✓	✓
Locking and unlocking parameters relevant to the measured value	✓ (only if display is connected)	✓	✓
Value acceptance indicated by the green LED	—	✓	✓
Switching damping on and off	✓ (only if display is connected)	✓	✓
Min. Switch on min. alarm	✓ (only if display is connected)	✓	✓

Operating the device using onsite display (optional)

A 4-line liquid crystal display (LCD) is used for display and operation. The onsite display shows measured values, dialog text as well as fault and notice messages in plain text, thereby supporting the user in every stage of operation.

The display can be removed for easy operation.

The device display can be turned in 90° steps.

Depending on the installation position of the device, this makes it easy to operate the device and read the measured value.

Functions:

- 8-digit measured value display including sign and decimal point, bargraph for 4 to 20 mA HART as current display.
- Simple and complete menu guidance due to breakdown of parameters into several levels and groups.
- Each parameter is given a 3-digit ID number for easy navigation.
- Option for configuring the display according to individual requirements and preferences, such as language, alternating display, display of other measured values such as sensor temperature, contrast setting.
- Comprehensive diagnostic functions (fault and warning message, peak-hold indicators, etc.).
- Quick and safe commissioning

Overview

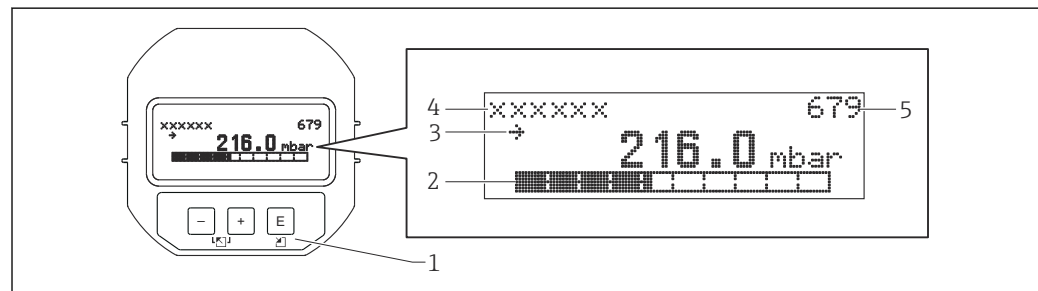

A0016498

- 1 Operating keys
- 2 Bargraph
- 3 Symbol
- 4 Header
- 5 Parameter ID number

Operating keys on the exterior of the device

With the T14 housing (aluminum or stainless steel), the operating keys are located either outside of the housing, under the protection cap or inside on the electronic insert. In addition, devices with an onsite display and a 4 to 20 mA HART electronic insert have operating keys on the onsite display.

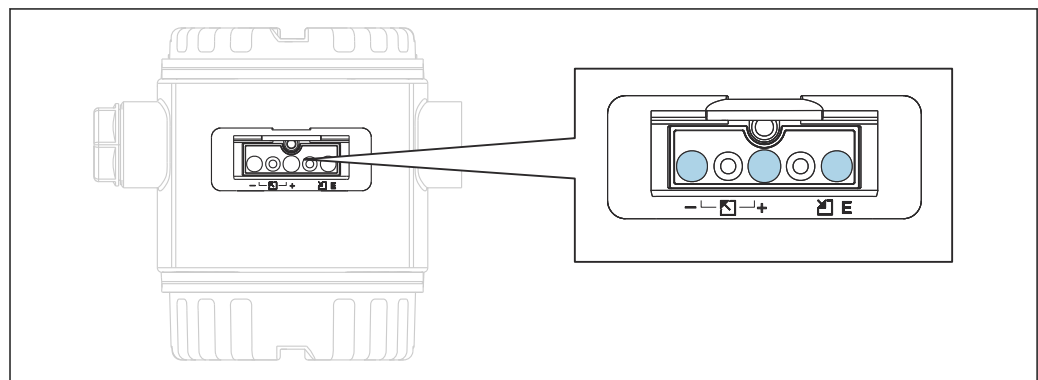

A0016499

The operating keys on the outside of the device make it unnecessary to open the housing. This guarantees:

- Complete protection against environmental influences such as moisture and contamination
- Simple operation without any tools
- No wear.

Operating keys and elements located internally on the electronic insert

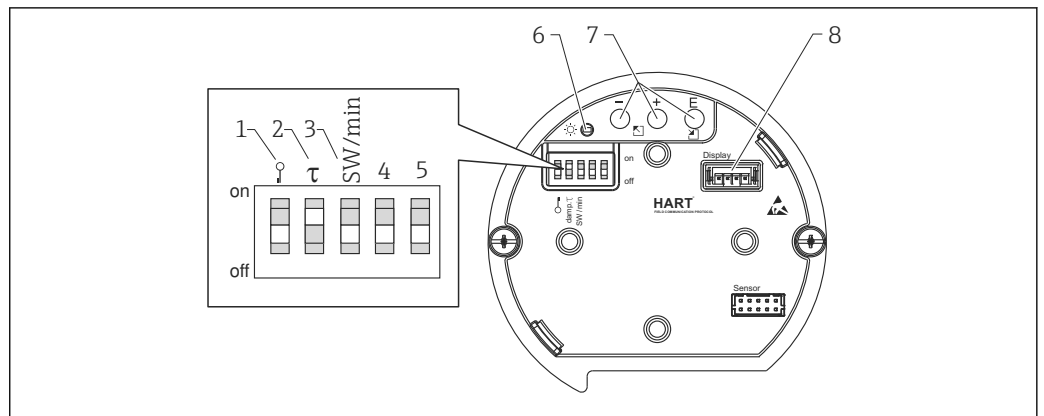

A0016500

- 1 DIP switch for locking/unlocking parameters relevant to the measured value
- 2 DIP switch for switching damping on/off
- 3 DIP switch for alarm current SW/Alarm min (3.6 mA)
- 4...5 Not assigned
- 6 Green LED to indicate value being accepted
- 7 Operating keys
- 8 Slot for optional display

Operating languages

You can also choose another language in addition to the standard language "English":

Description	Version ¹⁾
English (standard)	AA
German	AB
French	AC
Spanish	AD
Italian	AE
Portuguese	AG
Chinese simplified	AK
Japanese	AL

1) Product Configurator, "Additional operating language" section

Certificates and approvals

Current certificates and approvals for the product are available at www.endress.com on the relevant product page:

1. Select the product using the filters and search field.
2. Open the product page.
3. Select **Downloads**.

CE approval	The device meets the legal requirements of the relevant EC directives. Endress+Hauser confirms that the device has been successfully tested by applying the CE mark.
RoHS	FMD72: The measuring system complies with the substance restrictions of the Restriction on Hazardous Substances Directive 2011/65/EU (RoHS 2).
RCM marking	The supplied product or measuring system meets the ACMA (Australian Communications and Media Authority) requirements for network integrity, interoperability, performance characteristics as well as health and safety regulations. Here, especially the regulatory arrangements for electromagnetic compatibility are met. The products bear the RCM marking on the nameplate. <div style="text-align: center;"></div> <small style="text-align: right;">A0029561</small>
Ex approvals	<ul style="list-style-type: none"> ▪ ATEX ▪ FM ▪ CSA ▪ IECEX ▪ NEPSI <p>All explosion protection data are given in separate documentation which is available upon request. The Ex documentation is supplied as standard with all Ex-systems .</p>
Suitable for hygiene applications	For information on installation and approvals, see documentation SD02503F "Hygiene approvals". For information on 3-A and EHEDG-tested adapters, see documentation TI00426F "Weld-in adapter, process adapter and flanges".
Pressure Equipment Directive 2014/68/EU (PED)	<p>Pressure equipment with allowable pressure \leq 200 bar (2 900 psi)</p> <p>Pressure equipment (having a maximum allowable pressure $PS \leq$ 200 bar (2 900 psi)) can be classified as pressurized equipment in accordance with Pressure Equipment Directive 2014/68/EU. If the maximum allowable pressure is \leq 200 bar (2 900 psi) and the pressurized volume of the pressure equipment is \leq 0.1 l, the pressure equipment is subject to the Pressure Equipment Directive (cf. Pressure Equipment Directive 2014/68/EU, Article 4, point 3). The Pressure Equipment Directive only requires that the pressure equipment shall be designed and manufactured in accordance with the "sound engineering practice of a Member State".</p> <p><i>Reasons:</i></p> <ul style="list-style-type: none"> ▪ Pressure Equipment Directive (PED) 2014/68/EU Article 4, point 3 ▪ Pressure equipment directive 2014/68/EU, Commission's Working Group "Pressure", Guideline A-05 + A-06 <p><i>Note:</i></p> <p>A partial examination shall be performed for pressure instruments that are part of safety equipment for the protection of a pipe or vessel from exceeding allowable limits (equipment with safety function in accordance with Pressure Equipment Directive 2014/68/EU, Article 2, point 4).</p>

CRN approval

- FMD71: A CRN approval is available for some device versions. These devices are fitted with a separate plate bearing the registration number CRN OF23358.5C.
- FMD72: A CRN approval is available for some device versions. These devices are fitted with a separate plate bearing the registration number CRN OF10525.5C.

A CRN-approved process connection can be obtained in one of the following ways:

- CRN-approved process connection must be ordered with a CSA approval
- CRN-approved process connection must be ordered with the "CRN" option in the order code for "Additional approval"

Classification of process sealing between electrical systems and (flammable or combustible) process fluids in accordance with ANSI/ISA 12.27.01

Endress+Hauser devices are designed in accordance with ANSI/ISA 12.27.01, allowing the user to waive the use and save the cost of installing external secondary process seals in the conduit as required by the process sealing sections of ANSI/NFPA 70 (NEC) and CSA 22.1 (CEC). These instruments comply with the North-American installation practice and provide a very safe and cost-saving installation for pressurized applications with hazardous fluids. Please refer to the following table for the seal class assigned (single seal or dual seal):

Device	Approval	Single seal MWP
Deltabar FMD71/FMD72	CSA, FM IS, XP, NI	40 bar (580psi)

Further information can be found in the control drawings of the relevant devices.

Inspection certificates

Description	Option ¹⁾
3.1 Material certificate, wetted metallic parts, EN10204-3.1 inspection certificate	JA ²⁾
Conformity to NACE MR0175, wetted metallic parts	JB ²⁾
Helium leak test, internal procedure, inspection certificate	KD
Pressure test, internal procedure, inspection certificate	KE
PMI test (XRF), internal procedure, metal parts in contact with the medium, inspection certificate	KG

- 1) Product Configurator order code for "Test, certificate"
- 2) The selection of this feature for coated process isolating diaphragms / process connections refers to the metallic base material.

Ordering information

Detailed ordering information is available as follows:

- In the Product Configurator on the Endress+Hauser website: www.endress.com → Click "Corporate" → Select your country → Click "Products" → Select the product using the filters and search field → Open product page → The "Configure" button to the right of the product image opens the Product Configurator.
- From your Endress+Hauser Sales Center: www.addresses.endress.com



Product Configurator - the tool for individual product configuration

- Up-to-the-minute configuration data
 - Depending on the device: direct input of information specific to the measuring point, such as measuring range or operating language
 - Automatic verification of exclusion criteria
 - Automatic generation of the order code with its breakdown in PDF or Excel output format
 - Ability to order directly in the Endress+Hauser Online Shop

Scope of delivery

- Measuring device
- Optional accessories
- Brief Operating Instructions
- Certificates
- Mounting bracket

Measuring point (TAG)



Order code for	895: Marking
Option	Z1: Tagging (TAG), see additional spec.
Location of measuring point identification	To be selected in the additional specification: <ul style="list-style-type: none"> ▪ Tie-on label, stainless steel ▪ Adhesive paper label ▪ Label provided ▪ RFID TAG ▪ RFID TAG + tie-on label, stainless steel ▪ RFID TAG + adhesive paper label ▪ RFID TAG + label provided
Definition of measuring point identification	To be specified in additional specification: 3 lines each with a maximum of 18 characters The measuring point designation appears on the selected label and/or the RFID TAG.
Identification on electronic nameplate (ENP)	32 characters

Documentation

Field of Activities	Pressure measurement, powerful instruments for process pressure, differential pressure, level and flow: FA00004P/00/EN
Technical Information	<ul style="list-style-type: none">■ EMC test procedures TI00241F/00/EN■ Weld-in adapter, adapter and flanges: TI00426F/00/EN
Operating Instructions	BA01044P/00/EN
Brief Operating Instructions	KA01105P/00/EN - Brief Operating Instructions for devices SD00354P/00/A2 - Screening with Cable Shield
Safety Instructions (XA)	Depending on the approval, Safety Instructions (XA) are supplied with the device. The Safety Instructions are an integral part of the Operating Instructions.  Information on the Safety Instructions (XA) that are relevant for the device is provided on the nameplate.

Accessories

Service-specific accessories

Accessories	Description
DeviceCare SFE100	<p>Configuration tool for HART, PROFIBUS and FOUNDATION Fieldbus field devices</p> <p> Technical Information TI01134S</p> <p> DeviceCare is available for download at www.software-products.endress.com. You need to register in the Endress+Hauser software portal to download the application.</p>
FieldCare SFE500	<p>FDT-based plant asset management tool</p> <p>FieldCare can configure all smart field units in your plant and helps you manage them. By using the status information, FieldCare is also a simple but effective way of checking the status and condition of the field devices.</p> <p> Technical Information TI00028S</p>
FieldPort SFP20	<p>Mobile configuration tool for all IO-Link devices:</p> <ul style="list-style-type: none"> ■ Pre-installed device and CommDTMs in FieldCare ■ Pre-installed device and CommDTMs in FieldXpert ■ M12 connection for IO-Link field devices
Field Xpert SMT70, SMT77	<p>The Field Xpert SMT70 tablet PC for device configuration enables mobile plant asset management in hazardous (Ex Zone 2) and non-hazardous areas. It is suitable for commissioning and maintenance staff. It manages Endress+Hauser and third-party field instruments with a digital communication interface and documents the progress of the work. The SMT70 is designed as a complete solution. It comes with a pre-installed driver library and is an easy-to-use, touch-enabled tool for managing field devices throughout their entire life cycle.</p> <p>The Field Xpert SMT77 for device configuration enables mobile plant asset management in areas categorized as Ex Zone 1. It is suitable for commissioning and maintenance staff for easy management of field instruments with a digital communication interface. The touch-enabled tablet PC is designed as a complete solution. It comes with comprehensive pre-installed driver libraries and offers users a modern software user interface to manage field instruments throughout the entire life cycle.</p>

Registered trademarks

HART®

Registered trademark of the HART Communication Foundation, Austin, USA



71651081

www.addresses.endress.com
