

# Operating Instructions

## Proline Promag D 10

Electromagnetic flowmeter  
Modbus RS485





## Table of contents

<b>1</b>	<b>About this document</b>	<b>6</b>	<b>8</b>	<b>Commissioning</b>	<b>66</b>
	Document function	6		Post-installation check and post-connection check	66
	Related documentation	6		IT security	66
	Symbols	7		Device-specific IT security	66
	Registered trademarks	9		Switching on the device	67
				Commissioning the device	68
<b>2</b>	<b>Safety instructions</b>	<b>12</b>	<b>9</b>	<b>Operation</b>	<b>72</b>
	Requirements for specialist personnel	12		Reading off the device locking status	72
	Requirements for operating personnel	12		HistoROM data management	72
	Incoming acceptance and transport	12	<b>10</b>	<b>Diagnosis and troubleshooting</b>	<b>74</b>
	Adhesive labels, tags and engravings	12		General troubleshooting	74
	Environment and process	12		Diagnostic information via LED	75
	Workplace safety	12		Diagnostic information on local display	77
	Installation	12		Diagnostic information in FieldCare or DeviceCare	78
	Electrical connection	12		Changing the diagnostic information	79
	Surface temperature	13		Overview of diagnostic information	79
	Commissioning	13		Pending diagnostic events	82
	Modifications to the device	13		Diagnostic list	82
				Event logbook	83
<b>3</b>	<b>Product information</b>	<b>16</b>		Resetting the device	84
	Measuring principle	16	<b>11</b>	<b>Maintenance</b>	<b>88</b>
	Intended use	16		Maintenance work	88
	Incoming acceptance	16		Services	88
	Product identification	17	<b>12</b>	<b>Disposal</b>	<b>90</b>
	Transport	19		Removing the device	90
	Checking the storage conditions	21		Disposing of the device	90
	Recycling of packaging materials	21	<b>13</b>	<b>Technical data</b>	<b>92</b>
	Product design	22		Input	92
	Firmware history	24		Output	93
	Device history and compatibility	24		Energy supply	96
<b>4</b>	<b>Installation</b>	<b>26</b>		Cable specification	98
	Installation conditions	26		Performance characteristics	100
	Device installation	31		Environment	102
	Post-installation check	36		Process	104
<b>5</b>	<b>Electrical connection</b>	<b>38</b>		Mechanical construction	106
	Connecting requirements	38		Local display	111
	Connecting cable connection	39		Certificates and approvals	112
	Transmitter connection	43		Application packages	113
	Ensuring potential equalization	45	<b>14</b>	<b>Dimensions in SI units</b>	<b>116</b>
	Removing a cable	47		Compact version	116
	Hardware settings	48		Remote version	118
	Post-connection check	49		Flange connections	121
<b>6</b>	<b>Operation</b>	<b>52</b>		Couplings	124
	Overview of the operating options	52		Accessories	125
	Onsite operation	52			
	Operation via SmartBlue App	57			
<b>7</b>	<b>System integration</b>	<b>60</b>			
	Device description files	60			
	Modbus RS485 information	60			

<b>15</b>	<b>Dimensions in US units</b>	<b>128</b>
	Compact version	128
	Remote version	130
	Flange connections	133
	Couplings	134
	Accessories	135
<b>16</b>	<b>Accessories</b>	<b>138</b>
	Device-specific accessories	138
	Communication-specific accessories	139
	Service-specific accessory	139
	System components	140
<b>17</b>	<b>Appendix</b>	<b>142</b>
	Screw tightening torques	142
	Examples of electric terminals	144

**Index**

# 1 About this document

---

Document function	6
Related documentation	6
Symbols	7
Registered trademarks	9

## Document function



These Operating Instructions provide all of the information that is required in various phases of the life cycle of the device:

- Incoming acceptance and product identification
- Storage and transport
- Installation and connection
- Commissioning and operation
- Diagnostics and troubleshooting
- Maintenance and disposal

## Related documentation

Technical information	Overview of the device with the most important technical data.
Operating instructions	All the information that is required in the various phases of the life cycle of the device: from product identification, incoming acceptance and storage, to mounting, connection, operation and commissioning through to troubleshooting, maintenance and disposal as well as the technical data and dimensions.
Sensor Brief Operating Instructions	Incoming acceptance, transport, storage and mounting of the device.
Transmitter Brief Operating Instructions	Electrical connection and commissioning of the device.
Description of Parameters	Detailed explanation of the menus and parameters.
Safety Instructions	Documents for the use of the device in hazardous areas.
Special Documentation	Documents with more detailed information on specific topics.
Installation Instructions	Installation of spare parts and accessories.

The related documentation is available online:

Device Viewer	On the <a href="http://www.endress.com/deviceviewer">www.endress.com/deviceviewer</a> website, enter the serial number of the device: nameplate → <i>Product identification</i> ,  17
Endress+Hauser Operations App	<ul style="list-style-type: none"> <li>▶ Scan the Data Matrix code: nameplate → <i>Product identification</i>,  17</li> <li>▶ Enter the serial number of the device: nameplate → <i>Product identification</i>,  17</li> </ul>

## Symbols

### Warnings



This symbol alerts you to an immediate dangerous situation. Failure to avoid the situation will result in a fatal or serious injury.



This symbol alerts you to a potentially dangerous situation. Failure to avoid the situation may result in a fatal or serious injury.



This symbol alerts you to a potentially dangerous situation. Failure to avoid the situation may result in a minor or mild injury.



This symbol alerts you to a potentially harmful situation. Failure to avoid the situation may result in damage to the facility or to something in the facility's vicinity.

### Electronics

- Direct current
- Alternating current
- Direct current and alternating current
- Terminal connection for potential equalization

### Device communication





- Bluetooth is enabled.
- LED is off.
- LED flashing.
- LED lit.

### Tools



- Flat blade screwdriver
- Hexagon wrench
- Wrench

### Types of information

- Preferred procedures, processes or actions
- Permitted procedures, processes or actions
- Forbidden procedures, processes or actions
- Additional information
- Reference to documentation
- Reference to page
- Reference to graphic
- Measure or individual action to be observed

-  Series of steps
-  Result of a step
-  Help in the event of a problem
-  Visual inspection
-  Write-protected parameter

### Explosion protection

-  Hazardous area
-  Non-hazardous area



## Registered trademarks

### **Modbus®**

Registered trademark of SCHNEIDER AUTOMATION, INC.

### **Bluetooth®**

The Bluetooth word mark and Bluetooth logos are registered trademarks of Bluetooth SIG. Inc. and any use of such marks by Endress+Hauser is under license. Other trademarks and trade names are those of their respective owners.

### **Apple®**

Apple, the Apple logo, iPhone, and iPod touch are trademarks of Apple Inc., registered in the U.S. and other countries. App Store is a service mark of Apple Inc.

### **Android®**

Android, Google Play and the Google Play logo are trademarks of Google Inc.



## 2 Safety instructions

---

Requirements for specialist personnel	12
Requirements for operating personnel	12
Incoming acceptance and transport	12
Adhesive labels, tags and engravings	12
Environment and process	12
Workplace safety	12
Installation	12
Electrical connection	12
Surface temperature	13
Commissioning	13
Modifications to the device	13

## Requirements for specialist personnel

- ▶ Installation, electrical connection, commissioning, diagnostics and maintenance of the device must only be carried out by trained, specialist personnel authorized by the facility's owner-operator.
- ▶ Before commencing work, the trained, specialist personnel must carefully read, understand and adhere to the Operating Instructions, additional documentation and certificates.
- ▶ Comply with national regulations.

## Requirements for operating personnel

- ▶ Operating personnel are authorized by the facility's owner-operator and are instructed according to the requirements of the task.
- ▶ Before commencing work, the operating personnel must carefully read, understand and adhere to the instructions provided in the Operating Instructions and additional documentation.

## Incoming acceptance and transport

- ▶ Transport the device in a correct and appropriate manner.
- ▶ Do not remove protective covers or protective caps on the process connections.

## Adhesive labels, tags and engravings

- ▶ Pay attention to all the safety instructions and symbols on the device.

## Environment and process

- ▶ Only use the device for the measurement of appropriate media.
- ▶ Keep within the device-specific pressure range and temperature range.
- ▶ Protect the device from corrosion and the influence of environmental factors.

## Workplace safety

- ▶ Wear the required protective equipment according to national regulations.
- ▶ Do not ground the welding unit via the device.
- ▶ Wear protective gloves if working on and with the device with wet hands.

## Installation

- ▶ Do not remove protective covers or protective caps on the process connections until just before you install the sensor.
- ▶ Do not damage or remove the liner on the flange.
- ▶ Observe tightening torques.

## Electrical connection

- ▶ Comply with national installation regulations and guidelines.
- ▶ Observe cable specifications and device specifications.
- ▶ Check the cable for damage.

- ▶ If using the device in hazardous areas, observe the "Safety Instructions" documentation.
- ▶ Provide (establish) potential equalization.
- ▶ Provide (establish) grounding.

## Surface temperature

Media with elevated temperatures can cause the surfaces of the device to become hot. For this reason, note the following:

- ▶ Mount suitable touch protection.
- ▶ Wear suitable protective gloves.

## Commissioning

- ▶ Install the device only if it is in proper technical condition, free from errors and faults.
- ▶ Only put the device into operation once you have performed the post-installation check and post-connection check.

## Modifications to the device

Modifications or repairs are not permitted and can pose a danger. For this reason, note the following:

- ▶ Only carry out modifications or repairs after consulting beforehand with an Endress+Hauser service organization.
- ▶ Only use original spare parts and original accessories from Endress+Hauser.
- ▶ Install original spare parts and original accessories according to the Installation Instructions.



## 3 Product information

---

Measuring principle	16
Intended use	16
Incoming acceptance	16
Product identification	17
Transport	19
Checking the storage conditions	21
Recycling of packaging materials	21
Product design	22
Firmware history	24
Device history and compatibility	24

## Measuring principle

Electromagnetic flow measurement on the basis of *Faraday's law of magnetic induction*.

## Intended use

The device is only suitable for flow measurement of liquids with a minimum conductivity of 5  $\mu\text{S}/\text{cm}$ .

Depending on the version ordered, the device measures potentially explosive, flammable, poisonous and oxidizing media.

Devices for use in a hazardous area, in hygienic applications, or where there is an increased risk due to pressure, are labeled accordingly on the nameplate.

Non-designated use can compromise safety. The manufacturer is not liable for damage caused by improper or non-intended use.

## Incoming acceptance

Is technical documentation provided with the device?	<input type="checkbox"/>
Does the scope of supply match the specifications on the delivery note?	<input type="checkbox"/>
Is the order code on the delivery note and nameplate identical?	<input type="checkbox"/>
Does the device bear any signs of damage from transportation?	<input type="checkbox"/>
Has an incorrect device been ordered or delivered or has the device been damaged in transit? Complaints or returns: <a href="https://www.endress.com/support/return-material">https://www.endress.com/support/return-material</a>	<input type="checkbox"/>



## Product identification

### Device tag

The device comprises the following parts:

- Proline 10 transmitter
- Promag D sensor

### Transmitter nameplate

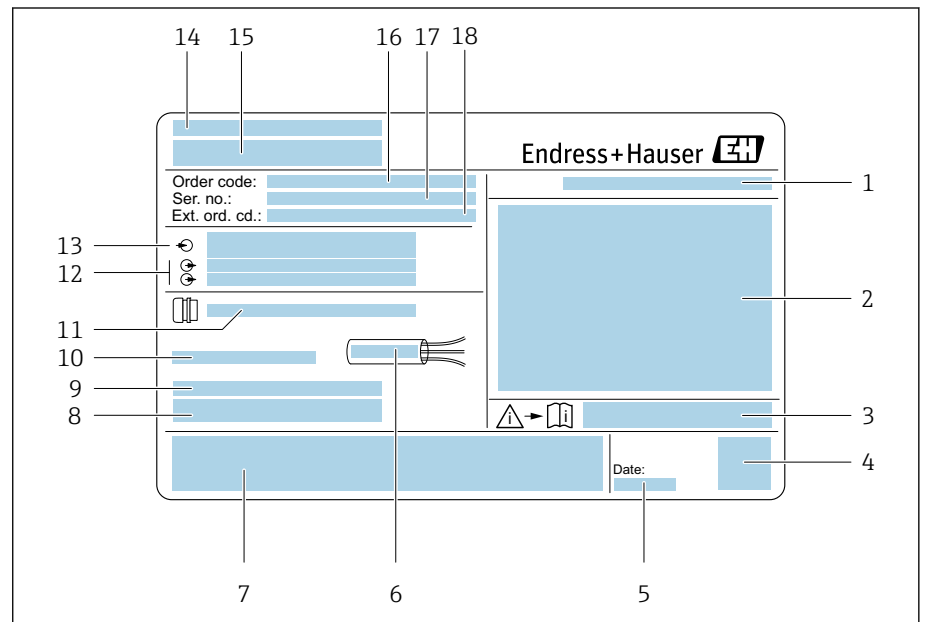

A0042943

1 Example of a transmitter nameplate

- 1 Degree of protection
- 2 Approvals for hazardous area, electrical connection data
- 3 Document number of safety-related supplementary documentation
- 4 Data Matrix code
- 5 Date of manufacture: year-month
- 6 Permitted temperature range for cable
- 7 CE mark and other approval marks
- 8 Firmware version (FW), device revision (Dev.Rev.) from the factory
- 9 Additional information in the case of special products
- 10 Permitted ambient temperature ( $T_a$ )
- 11 Information on the cable entry
- 12 Available inputs and outputs: supply voltage
- 13 Electrical connection data: supply voltage and supply power
- 14 Place of manufacture
- 15 Transmitter name
- 16 Order code
- 17 Serial number
- 18 Extended order code

## Sensor nameplate

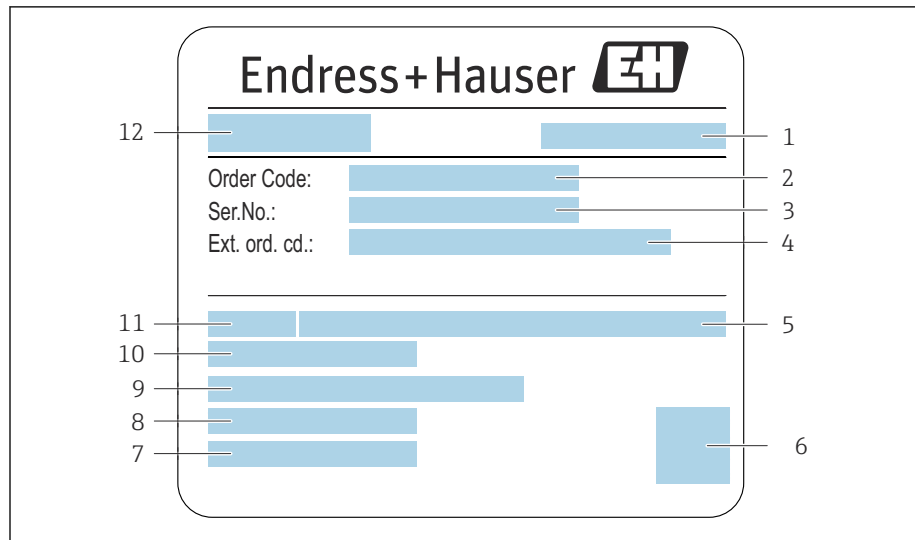

A0044151

 2 Example of sensor nameplate

- 1 Place of manufacture
- 2 Order code
- 3 Serial number (ser. no.)
- 4 Extended order code (ext. ord. cd.)
- 5 Nominal pressure
- 6 2-D matrix code
- 7 Degree of protection
- 8 Permitted ambient temperature range
- 9 Material of lining and electrodes
- 10 Medium temperature range
- 11 Nominal diameter of sensor
- 12 Name of the sensor

## Transport

### Protective packaging

Protective covers or protective caps are fitted on the process connections to protect against damage and dirt.

### Transporting in the original packaging

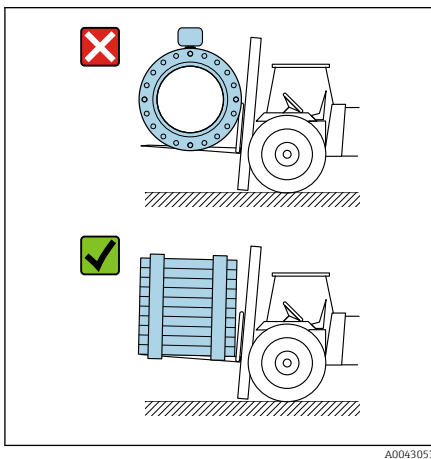

A0043053

#### NOTICE

##### Original packaging is missing!

Damage to the magnetic coil.

- ▶ Only lift and transport the device in the original packaging.

### Transporting with lifting lugs

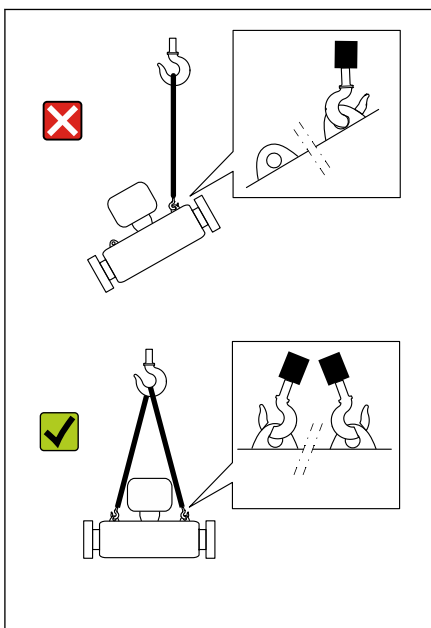

A0043058

#### ⚠ DANGER

##### Potentially life-threatening hazard from suspended loads!

The device could fall.

- ▶ Secure the device against slipping and turning.
- ▶ Do not move suspended loads over people.
- ▶ Do not move suspended loads over unprotected areas.

#### NOTICE

##### Lifting equipment incorrectly attached!

Lifting equipment attached on one side only can damage the device.

- ▶ Attach lifting equipment to both lifting lugs.

## Transporting without lifting lugs

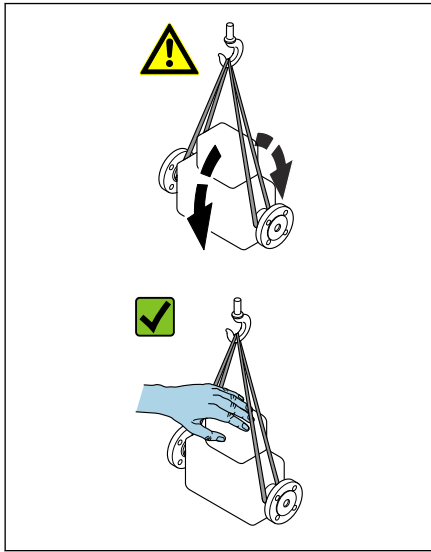

A0043054

### **⚠ DANGER**

#### **Potentially life-threatening hazard from suspended loads!**

The device could fall.

- ▶ Secure the device against slipping and turning.
- ▶ Do not move suspended loads over people.
- ▶ Do not move suspended loads over unprotected areas.

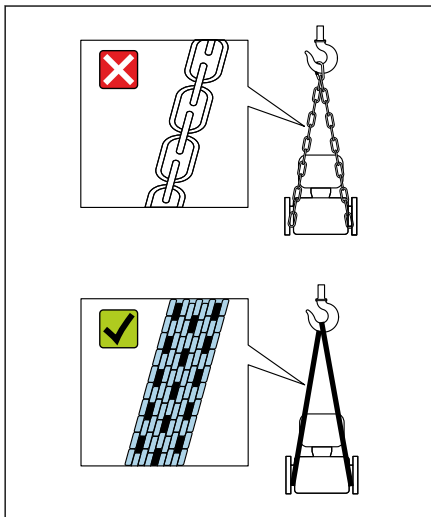

A0043055

### **NOTICE**

#### **Incorrect lifting equipment can damage the device!**

The use of chains as hoists can damage the device.

- ▶ Use textile hoists.

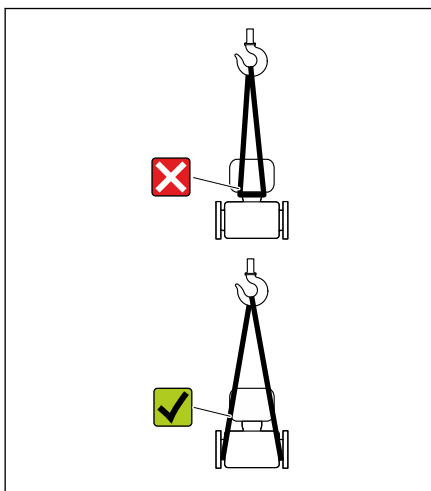

A0043056

### **NOTICE**

#### **Lifting equipment incorrectly attached!**

Lifting equipment attached to unsuitable points can damage the device.

- ▶ Attach lifting equipment to both process connections of the device.

## Checking the storage conditions

Are the protective covers or protection caps on the process connections?	<input type="checkbox"/>
Is the device in the original packaging?	<input type="checkbox"/>
Is the device protected against sunlight?	<input type="checkbox"/>
Is it guaranteed that the device is not stored outdoors?	<input type="checkbox"/>
Is the device stored in a dry and dust-free place?	<input type="checkbox"/>
Does the storage temperature match the device ambient temperature specified on the nameplate?	<input type="checkbox"/>
Is the possibility of moisture/condensation collecting on the device and original packaging as a result of variations in temperature ruled out?	<input type="checkbox"/>

## Recycling of packaging materials

All packaging materials and packaging aids must be recycled as specified by national regulations.

- Stretch wrap: polymer in accordance with EU Directive 2002/95/EC (RoHS)
- Crate: wood in accordance with ISPM 15 standard, confirmed by IPPC logo
- Cardboard box: in accordance with European Packaging Directive 94/62/EC, confirmed by Resy symbol
- Disposable pallet: plastic or wood
- Packaging straps: plastic
- Adhesive strips: plastic
- Padding: paper

## Product design

### Compact version

The transmitter and sensor form a mechanical unit.

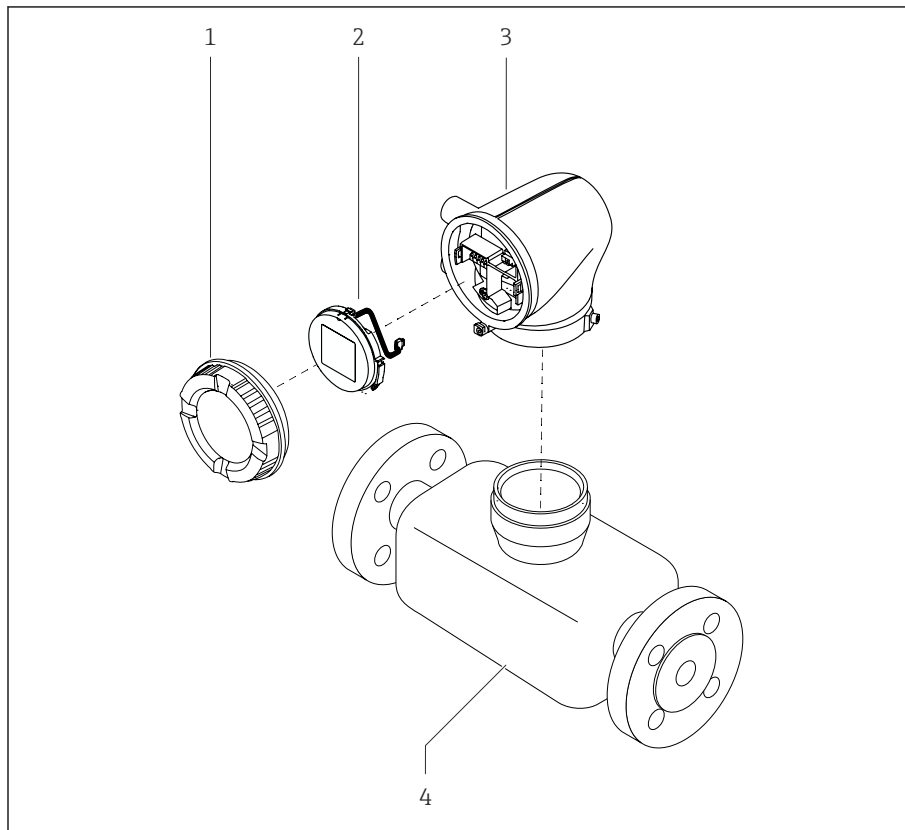

A0043525

#### 3 Main device components

- 1 Housing cover
- 2 Display module
- 3 Transmitter housing
- 4 Sensor

### Remote version

The transmitter and sensor are installed in physically separate locations.

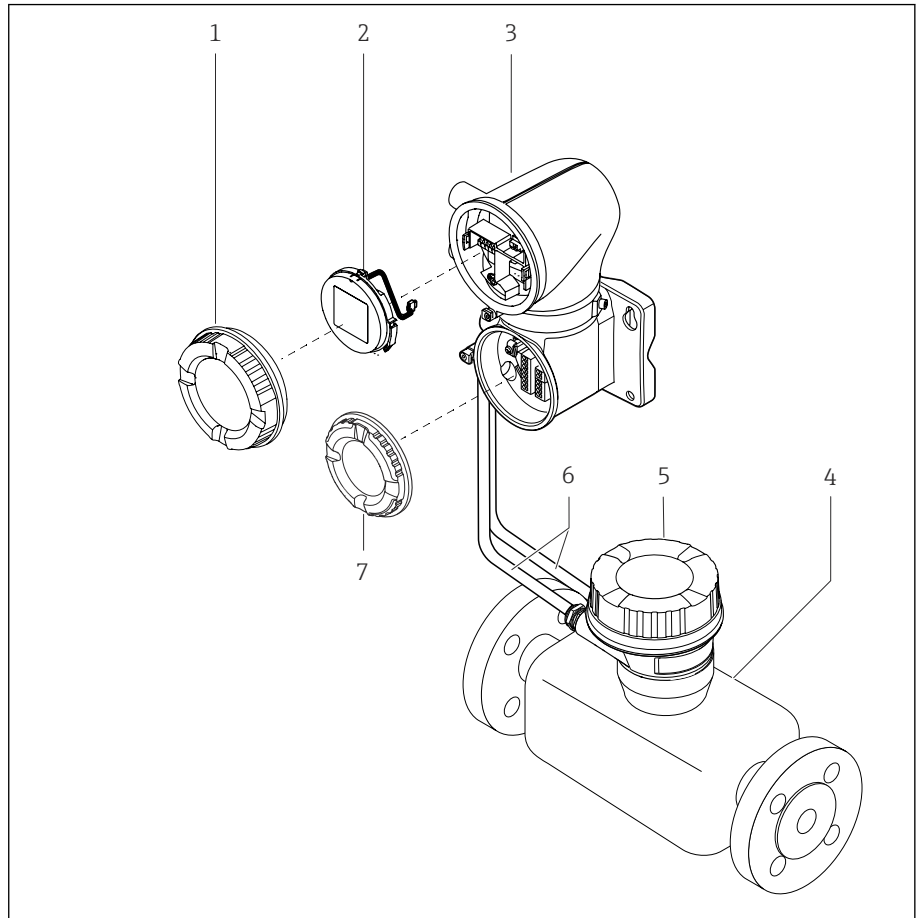

A0043524

#### 4 Main device components

- 1 Housing cover
- 2 Display module
- 3 Transmitter housing
- 4 Sensor
- 5 Sensor connection housing
- 6 Connecting cable consisting of coil current cable and electrode cable
- 7 Connection compartment cover

## Firmware history

List of firmware versions and changes since previous version

Firmware version 01.00.zz		
Release date	2021-07-01	Original firmware
Version of the Operating Instructions	01.21	
Order code for "Firmware version"	Option 77	

## Device history and compatibility

List of device models and changes since previous model

Device model A1		
Release	2021-08-01	-
Version of the Operating Instructions	01.21	
Compatibility with previous model	-	



## 4 Installation

---

Installation conditions	26
Device installation	31
Post-installation check	36

## Installation conditions

### Flow direction

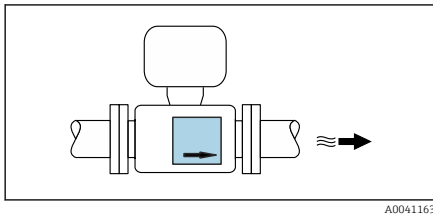

A0041163

Install the device in the direction of flow.



Note the direction of arrow on the nameplate.

### Installation with inlet runs and outlet runs

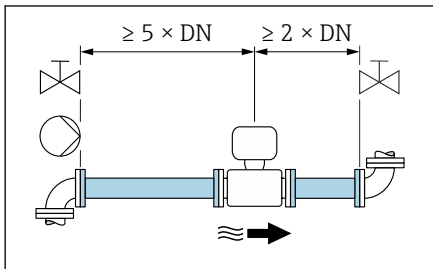

A0028997

Ensure straight, undisturbed inlet and outlet runs.



To avoid negative pressure and to comply with accuracy specifications, install the sensor upstream from assemblies that produce turbulence (e.g. valves, T-sections) and downstream from pumps → *Installation near pumps*, 29.

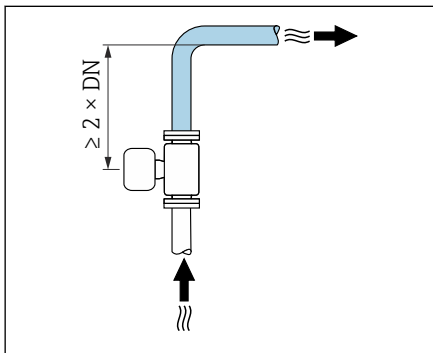

A0042132

Keep a sufficient distance to the next pipe elbow.

### Orientations

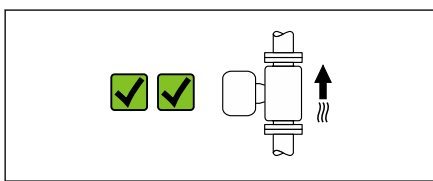

A0041159

#### Vertical orientation, upward direction of flow

For all applications.

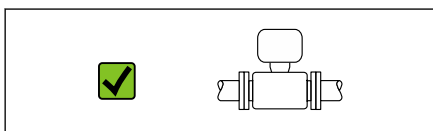

A0041160

#### Horizontal orientation, transmitter at top

This orientation is suitable for the following applications:

For low process temperatures in order to maintain the minimum ambient temperature for the transmitter.

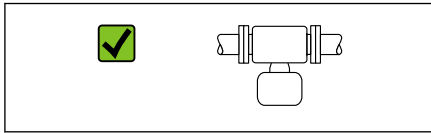

### Horizontal orientation, transmitter at bottom

This orientation is suitable for the following applications:

- For high process temperatures in order to maintain the maximum ambient temperature for the transmitter.
- To prevent the electronics module from overheating in the case of a sharp rise in temperature (e.g. CIP or SIP processes), install the measuring instrument with the transmitter component pointing downwards.

This orientation is not suitable for the following applications:

If empty pipe detection is to be used.

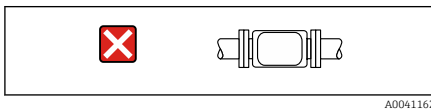

### Horizontal orientation, transmitter at side

This orientation is not suitable

### Vertical

Optimum for self-emptying pipe systems.

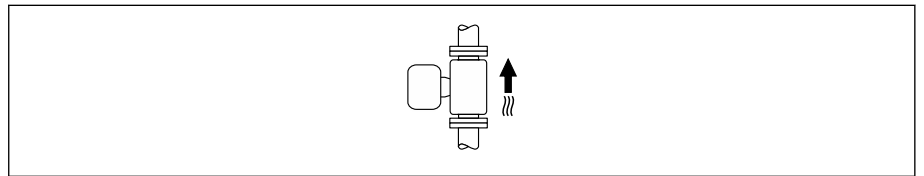

### Horizontal

Ideally, the measuring electrode plane should be horizontal. This prevents brief insulation of the measuring electrodes by entrained air bubbles.

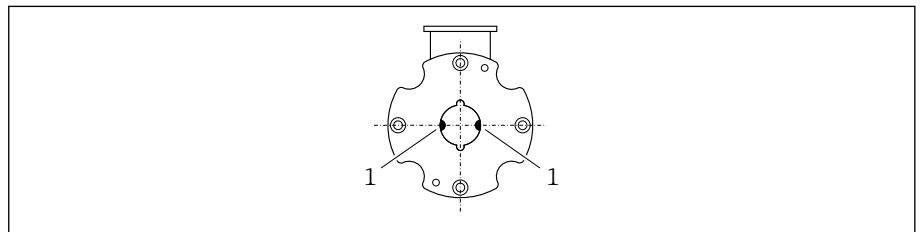

1 Measuring electrodes for signal detection

### Mounting locations

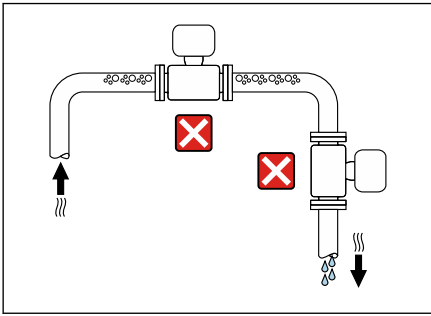

A0042131

- Do not install the device at the highest point of the pipe.
- Do not install the device upstream from a free pipe outlet in a down pipe.

The device should ideally be installed in an ascending pipe.

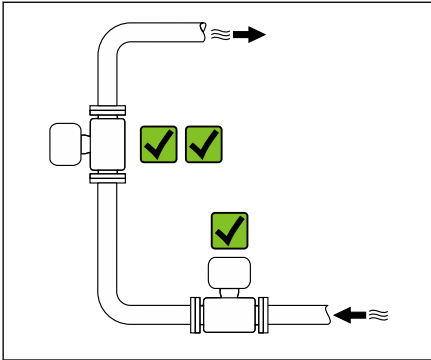

A0042317

### Installation near control valves

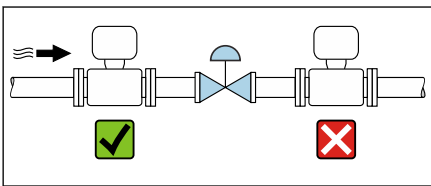

A0041091

Install the device in the direction of flow upstream from the control valve.

### Installation upstream from a down pipe

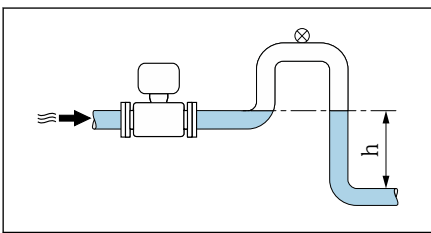

A0041089

#### NOTICE

**Negative pressure in the measuring pipe can damage the liner!**

- If installing upstream from down pipes with a length  $h \geq 5 \text{ m}$  (16.4 ft): install a siphon with a vent valve downstream from the device.

**i** This arrangement prevents the flow of liquid stopping in the pipe and air entrainment.

### Installation with partially filled pipes

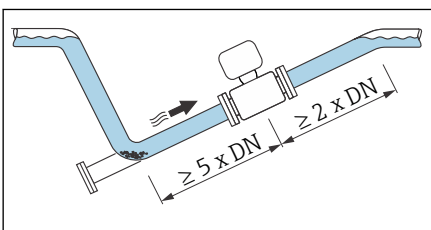

A0041088

- Partially filled pipes with a gradient require a drain-type configuration.
- The installation of a cleaning valve is recommended.

## Installation near pumps

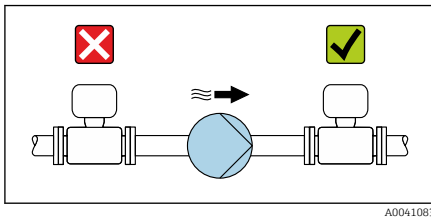

A0041083

### NOTICE

#### Negative pressure in the measuring pipe can damage the liner!

- ▶ Install the device in the direction of flow downstream from the pump.
- ▶ Install pulsation dampers if reciprocating, diaphragm or peristaltic pumps are used.



Information on the measuring system's resistance to vibration and shock  
→ *Vibration-resistance and shock-resistance*, 102

## Pipe vibrations

A remote version is recommended in the event of strong pipe vibrations.

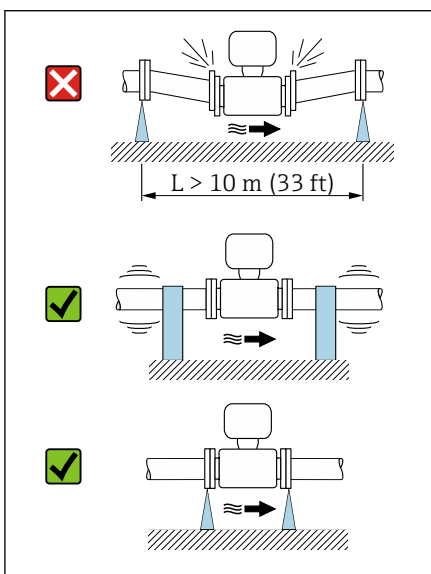

A0041092

### NOTICE

#### Pipe vibrations can damage the device!

- ▶ Do not expose the device to strong vibrations.
- ▶ Support the pipe and fix it in place.
- ▶ Support the device and fix it in place.
- ▶ Mount the sensor and transmitter separately.

### Adapters

Suitable adapters (double-flange reducers) can be used to install the sensor in larger-diameter pipes. The resulting higher rate of flow improves measuring accuracy with very slow-moving media.

**i** The nomogram shown here can be used to calculate the pressure loss caused by reducers and expanders. It only applies to liquids with a viscosity similar to that of water.

1. Calculate the ratio of the diameters  $d/D$ .
2. Determine the flow velocity after the reduction.
3. From the chart, determine the pressure loss as a function of the flow velocity  $v$  and the  $d/D$  ratio.

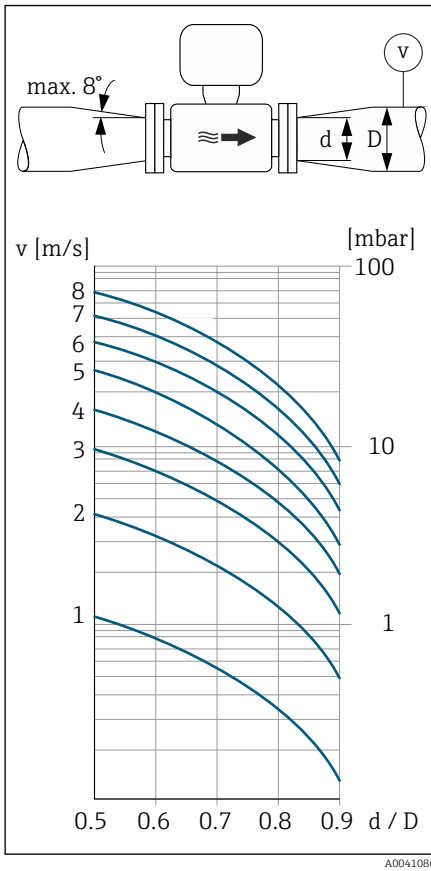

### Seals

Note the following when installing seals:

- Use seals with a hardness rating of 70° Shore.
- For DIN flanges: only install seals according to DIN EN 1514-1.

### Magnetism and static electricity

Do not install the device near magnetic fields, e.g. motors, pumps, transformers.

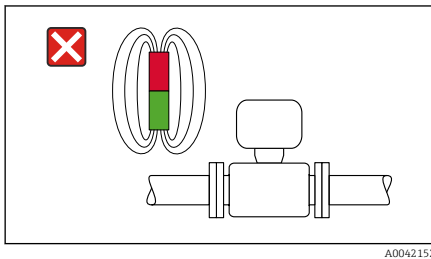

### Outdoor use

- Avoid exposure to direct sunlight.
- Install in a location protected from sunlight.
- Avoid direct exposure to weather conditions.
- Use a weather protection cover → *Transmitter*, 138.

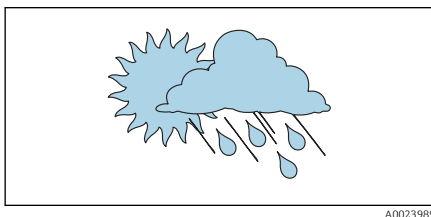

## Device installation

### Preparing the device

1. Remove the entire transportation packaging.
2. Remove protective covers or protective caps on the device.

### Installing seals

#### ⚠ WARNING

#### Improper process sealing can put staff at risk!

- ▶ Check whether the seals are clean and undamaged.

#### NOTICE

#### Incorrect installation can lead to incorrect measurement results!

- ▶ The internal diameter of the seal must be greater than or equal to that of the process connection and pipe.
- ▶ Fit the seals and measuring pipe centrally.
- ▶ Make sure that the seals do not protrude into the pipe cross-section.

### Installing the sensor

1. Ensure that the direction of the arrow on the sensor matches the flow direction of the medium.
2. Install and turn the device or transmitter housing in such a way that the cable entries point down or to the side.

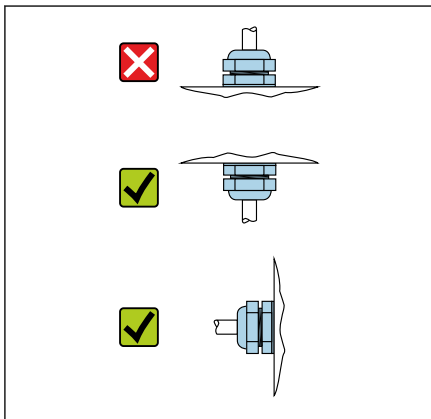

### Mounting kit

- i A mounting kit can be ordered separately → *Device-specific accessories*, 📄 138.

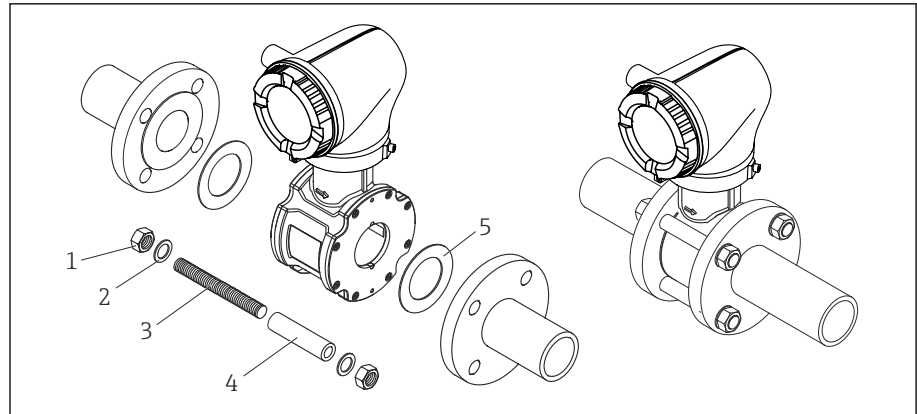

5 Mounting kit consisting of:

- 1 Nut
- 2 Washer
- 3 Mounting bolts
- 4 Centering sleeve
- 5 Seal

1. Mount the device between the pipe flanges with a mounting kit.
2. The device is centered using the recesses on the sensor.
3. Depending on the flange standard or diameter of the pitch circle, install the additional centering sleeves.
4. Observe tightening torques → *Screw tightening torques*, 142.

The arrangement of the mounting bolts and the use of the centering sleeves supplied are dependent on the nominal diameter, the flange standard and the diameter of the pitch circle.



### Arranging the mounting bolts and centering sleeves

The device is centered using recesses on the sensor. The arrangement of the mounting bolts and the use of the centering sleeves supplied are dependent on the nominal diameter, the flange standard and the diameter of the pitch circle.

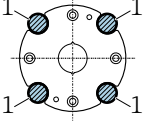
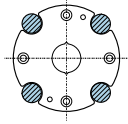
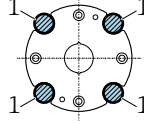
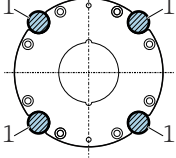
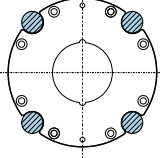
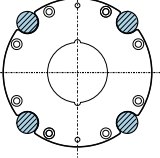
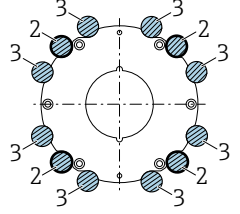
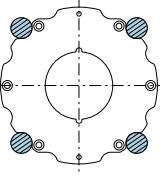
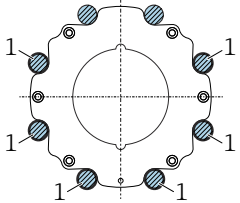
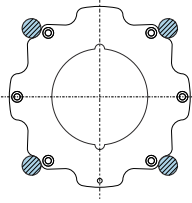
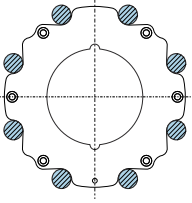
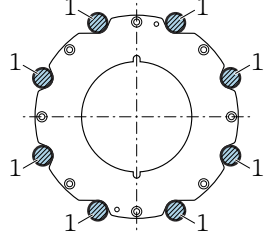
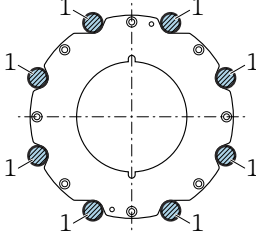
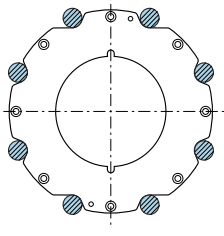
Nominal diameter		Process connection		
[mm]	[in]	EN 1092-1	ASME B16.5	JIS B2220
25 to 40	1 to 1 ½	 A0029490	 A0029491	 A0029490
50	2	 A0029492	 A0029493	 A0029493
65	2 ½	 A0029494	—	 A0029495
80	3	 A0029496	 A0029497	 A0029498
100	4	 A0029499	 A0029499	 A0029500

- 1 = Mounting bolts with centering sleeves
- 2 = EN (DIN) flange: 4-hole → with centering sleeves
- 3 = EN (DIN) flange: 8-hole → without centering sleeves

### Turning the transmitter housing

Order code for "Housing", option "Aluminum"

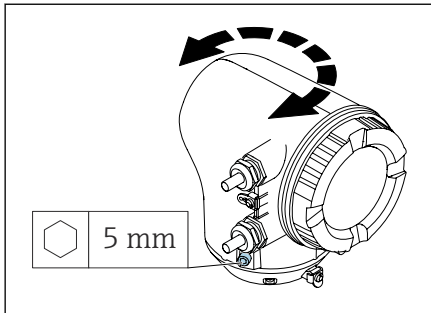

1. Loosen the fixing screws on both sides of the transmitter housing.

2. **NOTICE**

**Overrotation of the transmitter housing!**

Interior cables are damaged.

- ▶ Turn the transmitter housing a maximum of 180° in each direction.

Turn the transmitter housing to the desired position.

3. Tighten the screws in the logically reverse sequence.

Order code for "Housing", option "Polycarbonate"

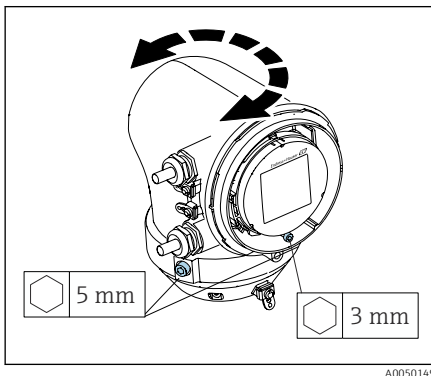

1. Loosen the screw on the housing cover.

2. Open the housing cover.

3. Loosen the grounding screw (below the display).

4. Loosen the fixing screws on both sides of the transmitter housing.

5. **NOTICE**

**Overrotation of the transmitter housing!**

Interior cables are damaged.

- ▶ Turn the transmitter housing a maximum of 180° in each direction.

Turn the transmitter housing to the desired position.

6. Tighten the screws in the logically reverse sequence.

### Mounting the transmitter on the wall

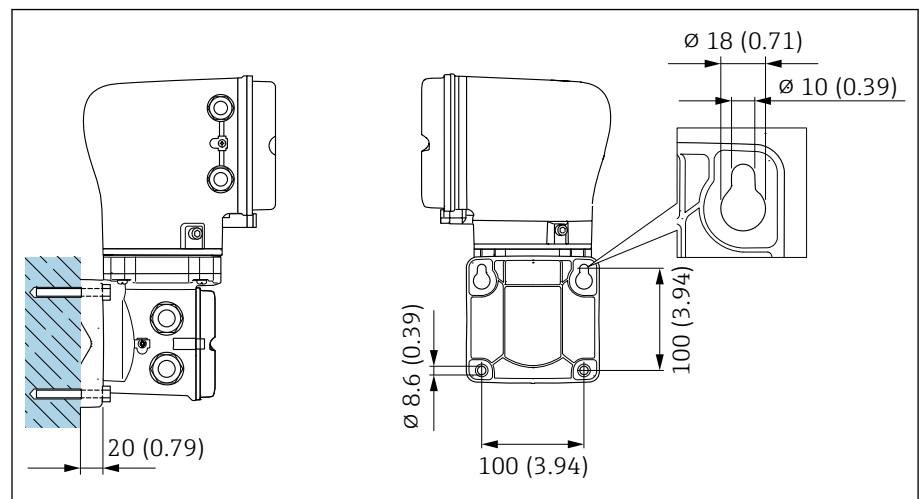

6 Unit mm (in)

**NOTICE**

**Ambient temperature too high!**

If the electronics overheat this can damage the transmitter housing.

- ▶ Do not exceed the permissible temperature range for the ambient temperature.
- ▶ Use a weather protection cover → *Transmitter*, 138.

- ▶ Mount the device correctly.

### Mounting the transmitter on a post

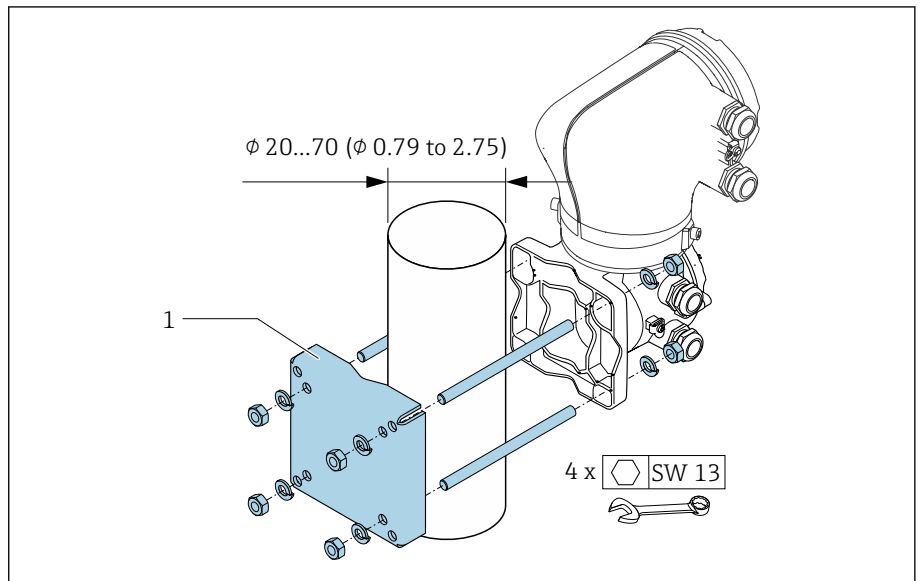

7 Unit mm (in)

#### NOTICE

##### Ambient temperature too high!

If the electronics overheat this can damage the transmitter housing.

- ▶ Do not exceed the permissible temperature range for the ambient temperature.
- ▶ Use a weather protection cover → *Transmitter*, 138.
- ▶ Mount the device correctly.

## Post-installation check

Is the device undamaged (visual inspection)?	<input type="checkbox"/>
Does the device comply with the measuring point specifications? For example: <ul style="list-style-type: none"><li>■ Process temperature</li><li>■ Process pressure</li><li>■ Ambient temperature</li><li>■ Measuring range</li></ul>	<input type="checkbox"/>
Has the correct orientation been selected for the device?	<input type="checkbox"/>
Does the direction of the arrow on the device match the flow direction of the medium?	<input type="checkbox"/>
Is the device protected against precipitation and sunlight?	<input type="checkbox"/>
Are the screws tightened with the correct tightening torque?	<input type="checkbox"/>

## 5 Electrical connection

---

Connecting requirements	38
Connecting cable connection	39
Transmitter connection	43
Ensuring potential equalization	45
Removing a cable	47
Hardware settings	48
Post-connection check	49

## Connecting requirements

### Notes on the electrical connection

#### WARNING

##### Live parts!

Incorrect work performed on the electrical connections can result in an electric shock.

- ▶ Have electrical connection work carried out by appropriately trained specialists only.
- ▶ Comply with applicable federal/national installation codes and regulations.
- ▶ Comply with national and local workplace safety regulations.
- ▶ Establish the connections in the correct order: always make sure to first connect the protective earth (PE) to the inner ground terminal.
- ▶ When using in hazardous areas, observe the "Safety Instructions" document.
- ▶ Ground the device carefully and provide potential equalization.
- ▶ Connect protective earthing to all outer ground terminals.

### Additional protective measures

The following protective measures are required:

- Set up a disconnecting device (switch or power-circuit breaker) to easily disconnect the device from the supply voltage.
- In addition to the device fuse, include an overcurrent protection unit, with max. 10 A, in the facility installation.
- Plastic sealing plugs act as safeguards during transportation and must be replaced by suitable, individually approved installation material.
- Connection examples: → *Examples of electric terminals*,  144

### Connecting the cable shield

 To avoid power (mains) frequency equalizing currents over the cable shield, the potential equalization of the facility must be ensured. If potential equalization (equipotential bonding) of the facility is not possible, only connect the cable shield to the facility on one side. Shielding against electromagnetic interference is then only partially ensured.

1. Keep stripped and twisted cable shields to the inner ground terminal as short as possible.
2. Shield cables fully.
3. Connect the cable shield to the potential equalization of the facility on both sides.

## Connecting cable connection

### Preparing the connecting cable

#### Transmitter

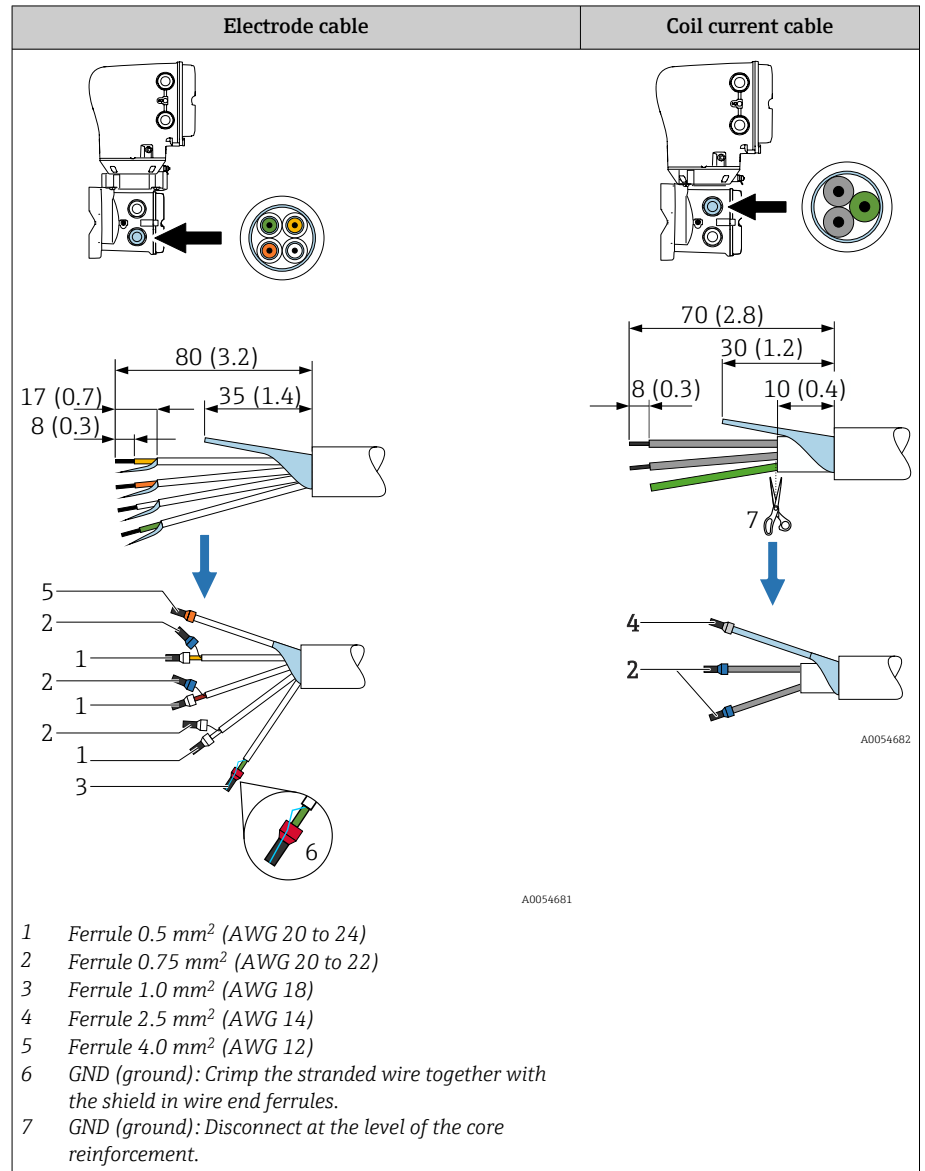

## Sensor

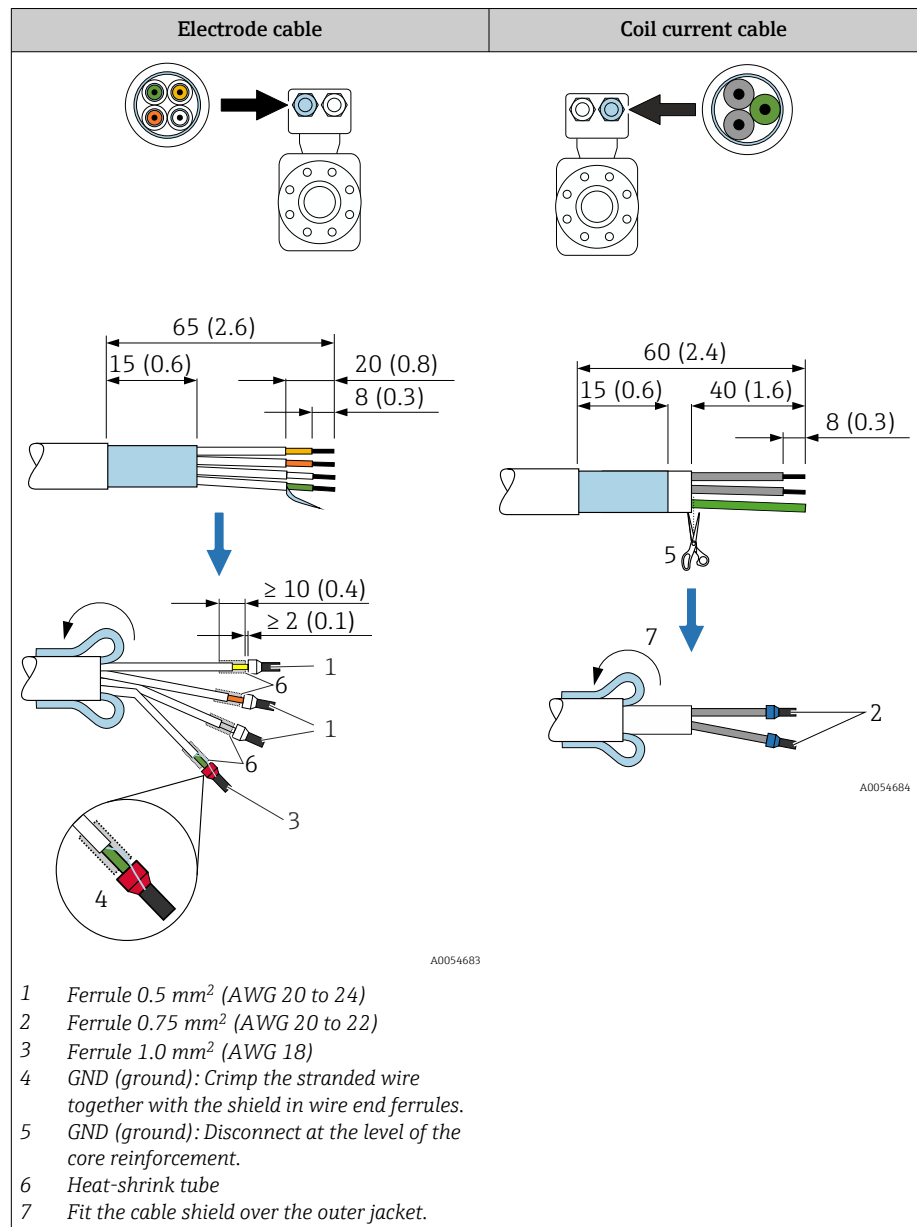

1. Make sure that the ferrules do not touch the cable shields on the sensor side. Minimum distance = 1 mm (exception: green "GND" cable)
2. A: Terminate the electrode cable.
3. B: Fit ferrules over the strands and press in place.
4. Fit the cable shield on the sensor side over the outer jacket.
5. Insulate the cable shield on the transmitter side, e.g. heat shrink tube.



## Connecting the connecting cable

### Wiring the sensor connection housing

#### NOTICE

#### Incorrect wiring can damage the electronic components!

- ▶ Only connect sensors and transmitters with identical serial numbers.
- ▶ Connect the sensor connection housing and the transmitter housing to the potential equalization of the facility via the outer ground terminal.
- ▶ Connect the sensor and transmitter to the same potential.

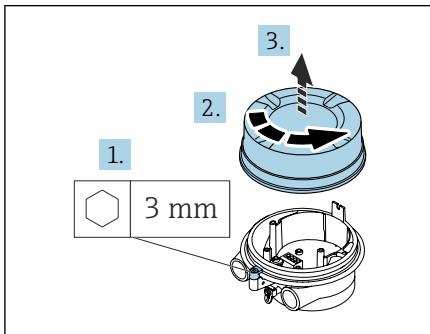

A0044138

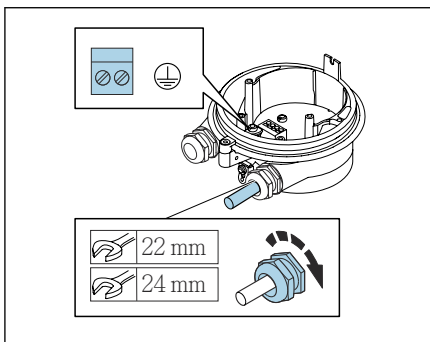

A0044139

1. Loosen the Allen key of the securing clamp.
2. Open the connection compartment cover counterclockwise.

#### NOTICE

#### If the sealing ring is missing, the housing is not sealed tight!

Damage to the device.

- ▶ Do not remove the sealing ring from the cable entry.
3. Feed the coil current cable and electrode cable through the corresponding cable entry.
  4. Adjust the cable lengths.
  5. Connect the cable shield to the inner ground terminal.
  6. Strip the cable and cable ends.
  7. Fit ferrules over the strands and press in place.
  8. Connect the coil current cable and the electrode cable as per the terminal assignment.
  9. Tighten the cable glands.
  10. Close the connection compartment cover.
  11. Fasten the securing clamp.

### Wiring the transmitter housing

#### NOTICE

#### Incorrect wiring can damage the electronic components!

- ▶ Only connect sensors and transmitters with identical serial numbers.
- ▶ Connect the sensor connection housing and the transmitter housing to the potential equalization of the facility via the outer ground terminal.
- ▶ Connect the sensor and transmitter to the same potential.

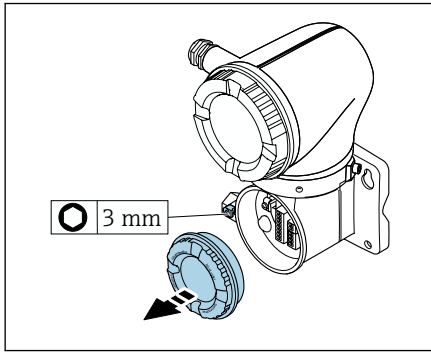

1. Loosen the Allen key of the securing clamp.
2. Open the connection compartment cover counterclockwise.

**NOTICE**

**If the sealing ring is missing, the housing is not sealed tight!**

Damage to the device.

- ▶ Do not remove the sealing ring from the cable entry.

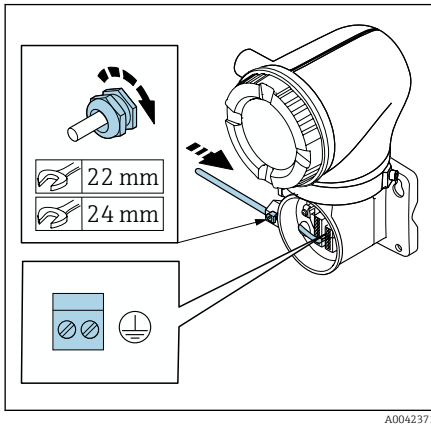

3. Feed the coil current cable and electrode cable through the corresponding cable entry.
4. Adjust the cable lengths.
5. Connect the cable shields to the inner ground terminal.
6. Strip the cable and cable ends.
7. Fit ferrules over the strands and press in place.
8. Connect the coil current cable and the electrode cable as per the terminal assignment.
9. Tighten the cable glands.
10. Close the connection compartment cover.
11. Fasten the securing clamp.

## Transmitter connection

### Transmitter terminal connections

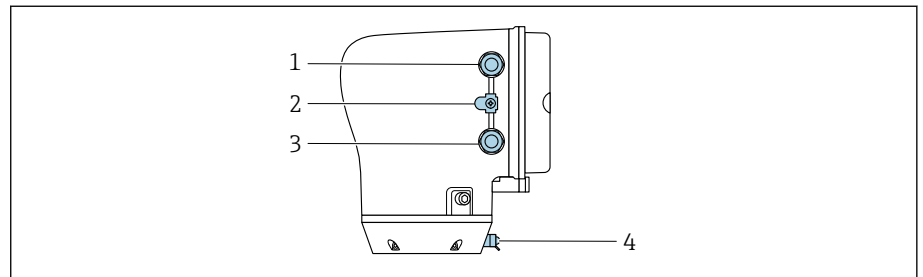

A0043283

- 1 Cable entry for power supply cable: supply voltage
- 2 Outer ground terminal: on transmitters made of polycarbonate with a metal pipe adapter
- 3 Cable entry for signal cable
- 4 Outer ground terminal

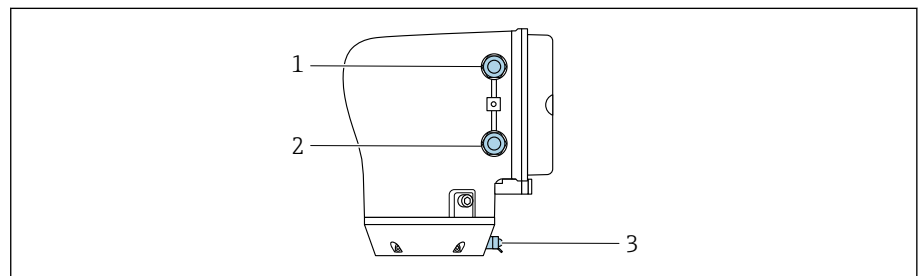

A0045438

- 1 Cable entry for power supply cable: supply voltage
- 2 Cable entry for signal cable
- 3 Outer ground terminal

### Terminal assignment

**i** The terminal assignment is documented on an adhesive label.

The following terminal assignment is available:

*Modbus RS485 and current output 4 to 20 mA (active)*

Supply voltage		Output 1				Output 2	
1 (+)	2 (-)	26 (+)	27 (-)	24 (+)	25 (-)	22 (B)	23 (A)
L/+	N/-	Current output 4 to 20 mA (active)		-		Modbus RS485	

*Modbus RS485 and current output 4 to 20 mA (passive)*

Supply voltage		Output 1				Output 2	
1 (+)	2 (-)	26 (+)	27 (-)	24 (+)	25 (-)	22 (B)	23 (A)
L/+	N/-	-		Current output 4 to 20 mA (passive)		Modbus RS485	

## Wiring the transmitter

- i** ■ Use a suitable cable gland for the power supply cable and signal cable.
- Pay attention to the requirements for the power supply cable and signal cable → *Requirements for connecting cable*, 98 .
- Use shielded cables for digital communication.

### NOTICE

**If the cable gland is incorrect, this compromises the sealing of the housing!**  
Damage to the device.

- ▶ Use a suitable cable gland corresponding to the degree of protection.

1. Ground the device carefully and provide potential equalization.
2. Connect protective earthing to the outer ground terminals.

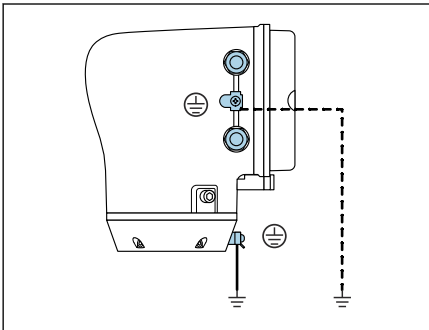

A0044720

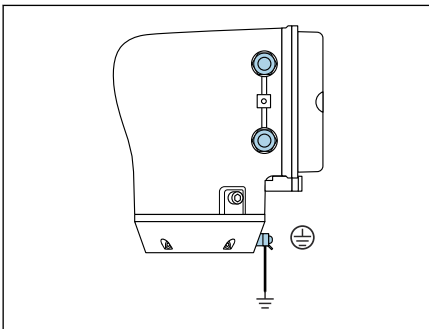

A0045442

3. Loosen the Allen key of the securing clamp.
4. Open the housing cover counterclockwise.

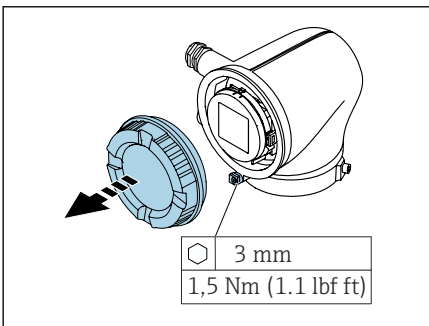

A0041094

5. Press the tab of the display module holder.
6. Remove the display module from the display module holder.

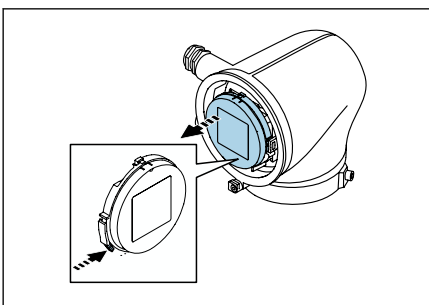

A0041330

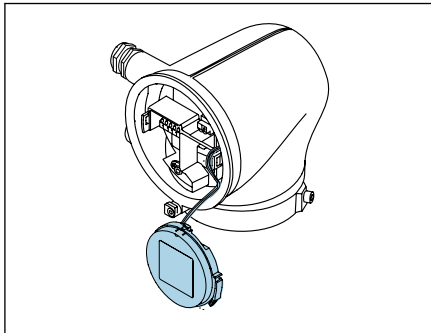

A0041354

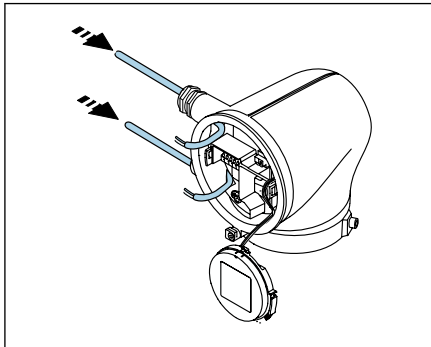

A0041356

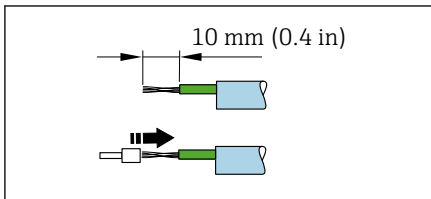

A0041357

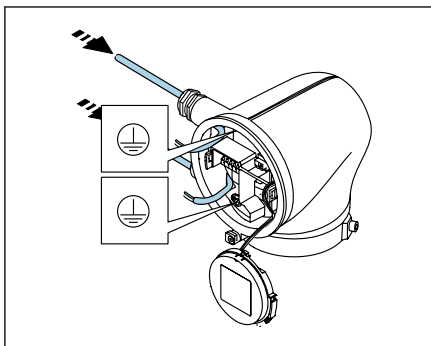

A0041358

**i** The cable must be in the tab for strain relief.

7. Let the display module hang down.

8. Remove dummy plug if present.

#### NOTICE

**If the sealing ring is missing, the housing is not sealed tight!**

Damage to the device.

► Do not remove the sealing ring from the cable entry.

9. Feed the power supply cable and signal cable through the corresponding cable entry.

10. Strip the cable and cable ends.

11. Fit ferrules over the strands and press in place.

**i** The terminal assignment is documented on an adhesive label.

12. Connect the protective ground (PE) to the inner ground terminal.

13. Connect the power supply cable and signal cable as per the terminal assignment.

14. Connect the cable shields to the inner ground terminal.

15. Tighten the cable glands.

16. Follow the sequence in the reverse order to reassemble.

## Ensuring potential equalization

### Introduction

Correct potential equalization (equipotential bonding) is a prerequisite for stable and reliable flow measurement. Inadequate or incorrect potential equalization can result in device failure and present a safety hazard.

The following requirements must be observed to ensure correct, trouble-free measurement:

- The principle that the medium, the sensor and the transmitter must be at the same electrical potential applies.
- Take in-company grounding guidelines, materials and the grounding conditions and potential conditions of the pipe into consideration.
- The necessary potential equalization connections must be established using a ground cable with a minimum cross-section of 6 mm<sup>2</sup> (0.0093 in<sup>2</sup>). Also use a cable lug.
- In the case of remote device versions, the ground terminal in the example always refers to the sensor and not to the transmitter.

#### Abbreviations used

- PE (Protective Earth): potential at the potential equalization terminals of the device
- P<sub>p</sub> (Potential Pipe): potential of the pipe, measured at the flanges
- P<sub>M</sub> (Potential Medium): potential of the medium

### Connection examples for standard situations

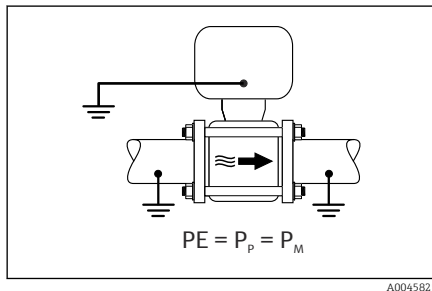

#### Unlined and grounded metal pipe

- Potential equalization is via the measuring pipe.
- The medium is set to ground potential.

Starting conditions:

- Pipes are correctly grounded on both sides.
  - Pipes are conductive and at the same electrical potential as the medium
- ▶ Connect the connection housing of the transmitter or sensor to ground potential via the ground terminal provided for this purpose.

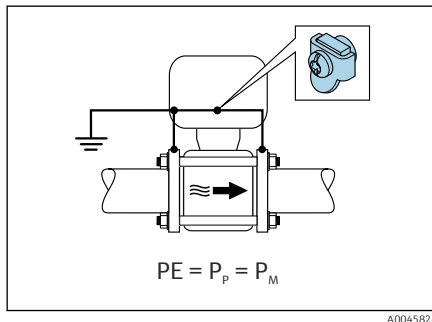

#### Plastic pipe or pipe with insulating liner

- Potential equalization is via the ground terminal and flanges
- The medium is set to ground potential.

Starting conditions:

- The pipe has an insulating effect.
- Low-impedance medium grounding close to the sensor is not guaranteed.
- Equalizing currents through the medium cannot be ruled out.

1. Connect flanges to the ground terminal of the transmitter or sensor connection housing via the ground cable.
2. Connect the connection to ground potential.

## Connection example with the potential of medium not equal to potential equalization connection

In these cases, the medium potential can differ from the potential of the device.

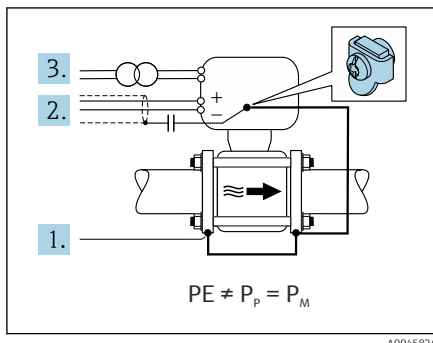

### Metal, ungrounded pipe

The sensor and transmitter are installed in a way that provides electrical insulation from PE, e.g. applications for electrolytic processes or systems with cathodic protection.

Starting conditions:

- Unlined metal pipe
- Pipes with an electrically conductive liner

1. Connect the pipe flanges and transmitter via the ground cable.
2. Route the shielding of the signal lines via a capacitor (recommended value 1.5µF/50V).
3. Device connected to power supply such that it is floating in relation to the potential equalization connection (isolation transformer). This measure is not required in the case of 24V DC supply voltage without PE (= SELV power unit).

## Removing a cable

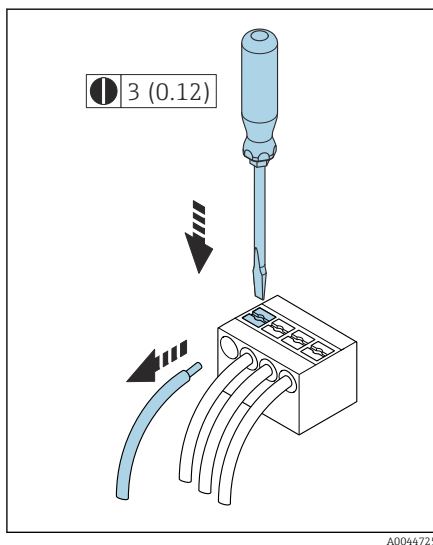

8 Engineering unit mm (in)

1. Use a flat-blade screwdriver to press down on the slot between the two terminal holes and hold.
2. Remove the cable end from the terminal.

## Hardware settings

### Enabling write protection

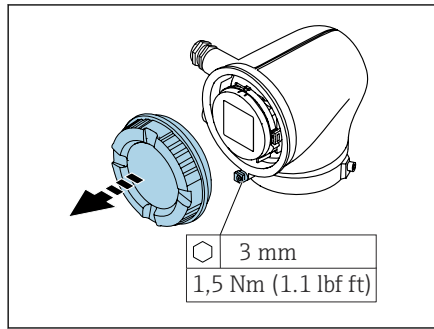

A0041094

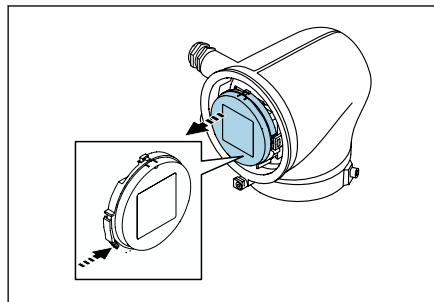

A0041330

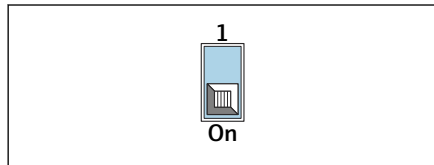

A0044412

1. Loosen the Allen key of the securing clamp.
2. Open the housing cover counterclockwise.
3. Press the tab of the display module holder.
4. Remove the display module from the display module holder.
5. Set the write protection switch on the back of the display module to the **On** position.
  - ↳ Write protection is enabled.
6. Follow the sequence in the reverse order to reassemble.

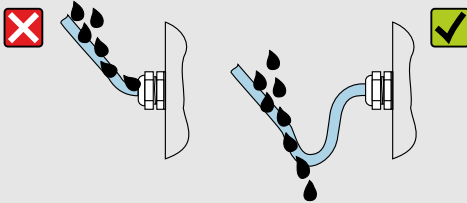

### Post-connection check

Only for remote version: Is the serial number on the nameplates of the connected sensor and transmitter identical?	<input type="checkbox"/>
Is the potential equalization established correctly?	<input type="checkbox"/>
Is the protective earthing established correctly?	<input type="checkbox"/>
Are the device and cable undamaged (visual check)?	<input type="checkbox"/>
Do the cables meet the requirements?	<input type="checkbox"/>
Is the terminal assignment correct?	<input type="checkbox"/>
Are all the cable glands installed, firmly tightened and leak-tight?	<input type="checkbox"/>
Are dummy plugs inserted in unused cable entries?	<input type="checkbox"/>
Are transportation plugs replaced by dummy plugs?	<input type="checkbox"/>
Are the housing screws and housing cover tightened?	<input type="checkbox"/>
Do the cables loop down before the cable gland ("water trap")?	<input type="checkbox"/>
	<input type="checkbox"/>
Does the supply voltage match the specifications on the transmitter nameplate?	<input type="checkbox"/>

A0042316



## 6 Operation

---

Overview of the operating options	52
Onsite operation	52
Operation via SmartBlue App	57

## Overview of the operating options

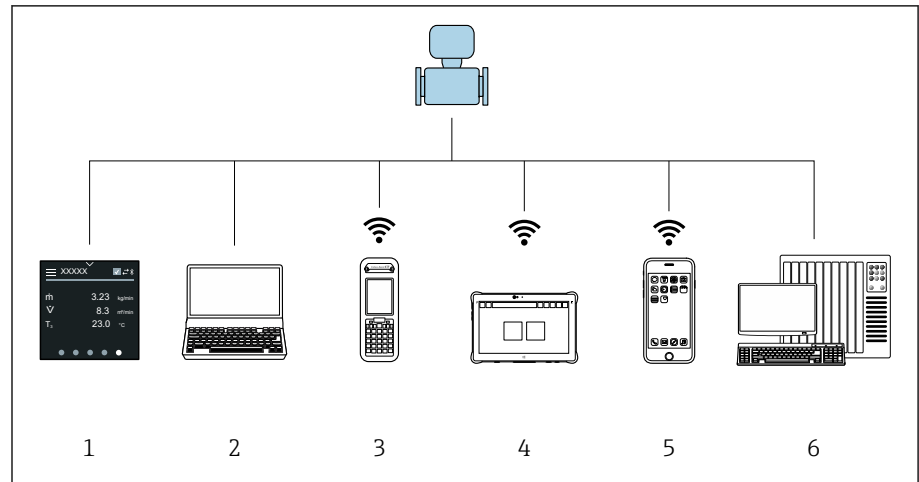

- 1 Local operation via touch screen
- 2 Computer with operating tool, e.g. FieldCare, DeviceCare, AMS Device Manager, SIMATIC PDM
- 3 Field Xpert SFX350 or SFX370 via Bluetooth, e.g. SmartBlue App
- 4 Field Xpert SMT70 via Bluetooth, e.g. SmartBlue App
- 5 Tablet or smartphone via Bluetooth, e.g. SmartBlue App
- 6 Automation system, e.g. PLC

## Onsite operation

### Unlocking local operation

Local operation must first be unlocked before the device can be operated via the touch screen. To unlock, draw the pattern "L" on the touch screen.

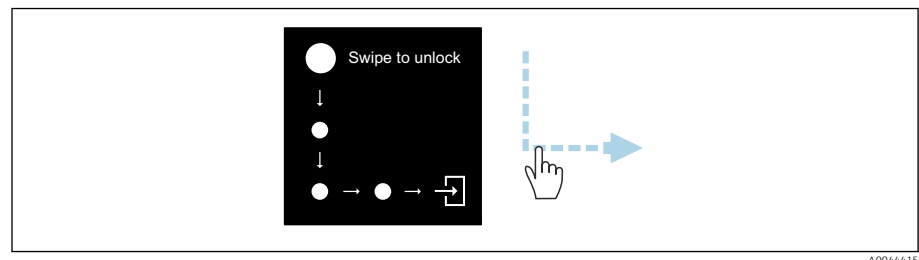

## Navigation

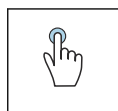

### Tap

- Open menus.
- Select items in a list.
- Acknowledge buttons.
- Enter characters.

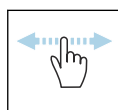

### Swipe horizontally

Display next or previous page.

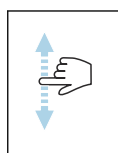

### Swipe vertically

Display additional points in a list.

## Operational display

During routine operation, the local display shows the operational display screen. The operational display comprises several windows that the user can toggle between.

**i** The operational display can be customized: see the description of parameters → *Main menu*, 54.

## Operational display and navigation

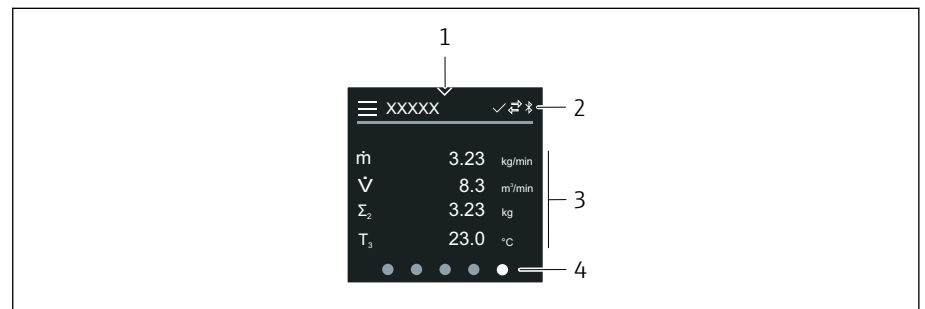

A0042992

- 1 Quick access
- 2 Status symbols, communication symbols and diagnostic symbols
- 3 Measured values
- 4 Rotating page display

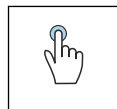

### Tap

- Open the main menu.
- Open quick access.

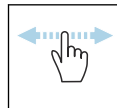

### Swipe horizontally

Display next or previous page.

## Symbols

- ☰ Open the main menu.
- ✓ Quick access
- 🔒 Locking status
- 📶 Bluetooth is active.
- ↔ Device communication is enabled.
- ▽ Status signal: function check
- ⬢ Status signal: maintenance required
- ⚠ Status signal: out of specification
- ⊗ Status signal: failure
- ☑ Status signal: diagnostics active.

## Quick access

The Quick access menu contains a selection of specific device functions.

**i** Quick access is indicated by a triangle at the top of the local display in the middle.

### Quick access and navigation

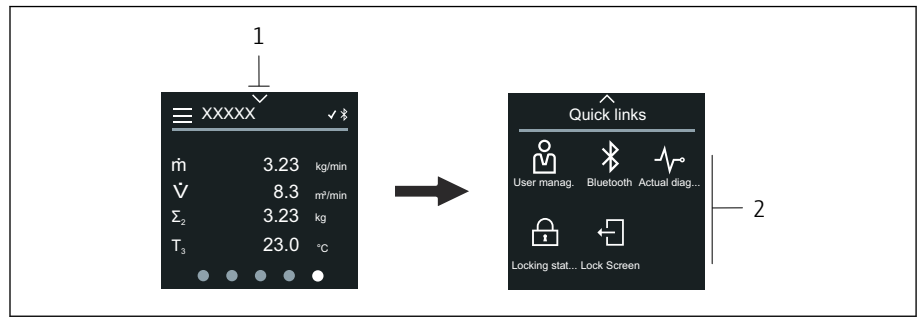

A0044208

- 1 Quick access
- 2 Quick access with specific device functions

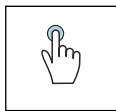

#### Tap

- Back to operational display.
- Open specific device functions.

#### Symbols

When a symbol is tapped, the local display shows the menu with the corresponding specific device functions.

- ⌘ Enable or disable Bluetooth.
- 🔑 Enter access code.
- 🔒 Write protection is enabled.
- ✕ Back to operational display.

### Main menu

The main menu contains all the menus required for the commissioning, configuration and operation of the device.

#### Main menu and navigation

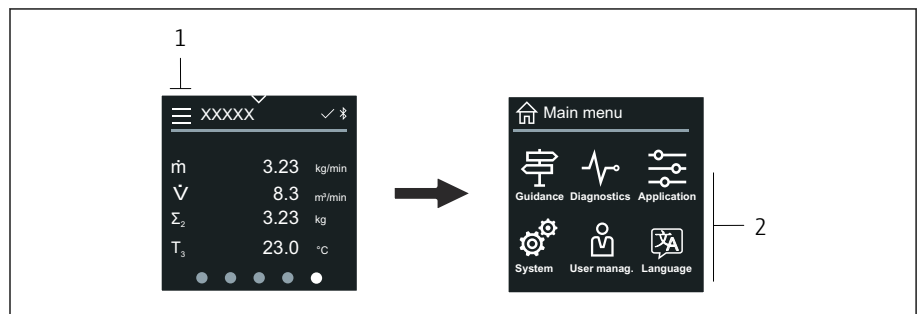

A0044213



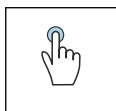



- 1 Open the main menu.
- 2 Open menus for the specific device functions.



#### Tap

- Back to operational display.
- Open menus.

### Symbols

-  Back to operational display.
-  **Guidance** menu  
Configuration of the device
-  **Diagnostics** menu  
Troubleshooting and control of device behavior
-  **Application** menu  
Application-specific adjustments
-  **System** menu  
Device management and user administration
-  Set display language.

### Submenus and navigation



A0044219

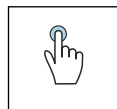

#### Tap

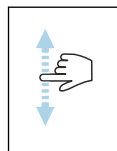

- Open the main menu.
- Open submenus or parameters.
- Select options.
- Skip items in list.



#### Swipe vertically

Select items in a list on a step-by-step basis.

### Symbols

-  Return to previous menu.
-  Skip to bottom of list.
-  Skip to top of list.

### Diagnostic information

Diagnostic information displays additional instructions or background information for diagnostic events.

#### Opening the diagnostic message

-  The diagnostic behavior is indicated on the top right of the local display by a diagnostics symbol. Tap the symbol or the "Help" button to open the diagnostic message.

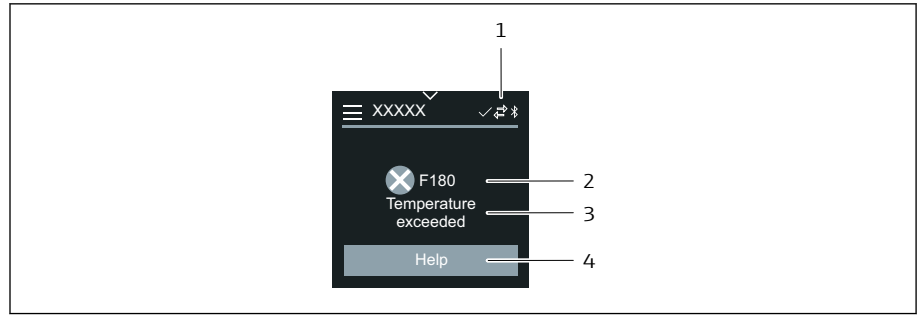

A0043008

- 1 Device status
- 2 Diagnostic behavior with diagnostic code
- 3 Short text
- 4 Open the troubleshooting measures.

## Editing view

### Editor and navigation

The text editor is used to enter characters.

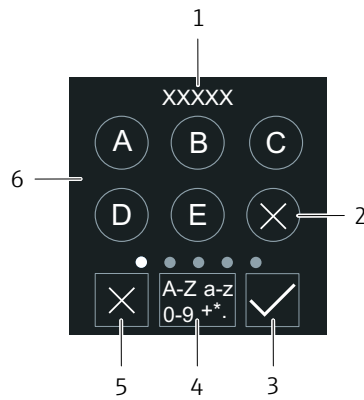

A0043020

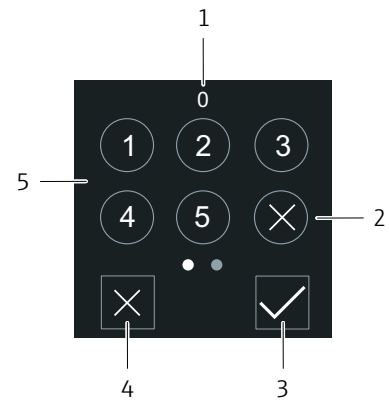

A0043023

- 1 Entry display area
- 2 Delete character.
- 3 Confirm your entry.
- 4 Switch input field.
- 5 Cancel editor.
- 6 Input field

- 1 Entry display area
- 2 Delete character.
- 3 Confirm your entry.
- 4 Cancel editor.
- 5 Input field

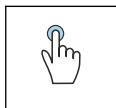

### Tap

- Enter characters.
- Select next character set.

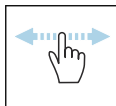

### Swipe horizontally

Display next or previous page.

### Input field

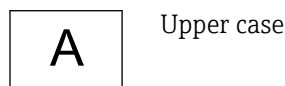





Numbers

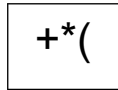

Special characters

### Date

The device has a real-time clock for all log functions. The time can be configured here.

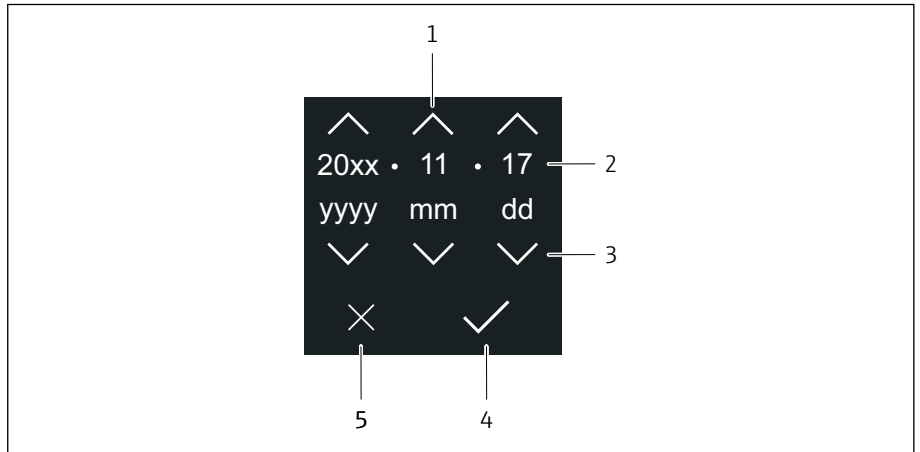

A0043043

- 1 Increase date by 1.
- 2 Actual value
- 3 Decrease date by 1.
- 4 Confirm settings.
- 5 Cancel editor.

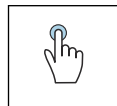

### Tap

- Make settings.
- Confirm settings.
- Cancel editor.

## Operation via SmartBlue App

The device can be operated and configured with the SmartBlue App.

- The SmartBlue App must be downloaded onto a mobile device for this purpose.
- For information on the compatibility of the SmartBlue App with mobile devices, see **Apple App Store (iOS devices)** or **Google Play Store (Android devices)**.
- Incorrect operation by unauthorized persons is prevented by means of encrypted communication and password encryption.
- The Bluetooth® function can be deactivated after initial device setup.

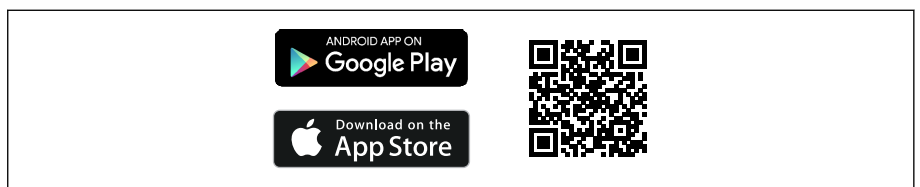



A0033202

9 QR code for free Endress+Hauser SmartBlue App

Download and installation:

1. Scan the QR code or enter **SmartBlue** in the search field of the Apple App Store (iOS) or Google Play Store (Android).
2. Install and start the SmartBlue App.
3. For Android devices: enable location tracking (GPS) (not required for iOS devices).
4. Select a device that is ready to receive from the device list displayed.

Login:

1. Enter the user name: admin
  2. Enter the initial password: serial number of the device
-  Change the password after logging in for the first time.
-  Forgotten your password? Contact Endress+Hauser Service.

# 7 System integration

---

Device description files	60
Modbus RS485 information	60

## Device description files

### Version data

Firmware version	01.00.zz	<ul style="list-style-type: none"> <li>On the title page of the Operating instructions</li> <li>On the transmitter nameplate → <i>Transmitter nameplate</i>,  17</li> <li>System → Information → Device → Firmware version</li> </ul>
Release date of firmware version	04.2021	-

### Operating tools

The suitable device description file for the individual operating tools is listed in the table below, along with information on where the file can be obtained.



Operating tools via service interface (CDI) or Modbus interface	Sources for obtaining device descriptions
FieldCare	<ul style="list-style-type: none"> <li><a href="http://www.endress.com">www.endress.com</a> → Downloads</li> <li>USB stick (contact Endress+Hauser)</li> </ul>
DeviceCare	<ul style="list-style-type: none"> <li><a href="http://www.endress.com">www.endress.com</a> → Downloads</li> <li>USB stick (contact Endress+Hauser)</li> </ul>

## Modbus RS485 information

 Technical data → *Protocol-specific data*,  94

### Function codes

The function code determines which read or write actions should be performed via the Modbus protocol.

Code	Name	Description	Application
03	Read holding register	Modbus master reads 1 Modbus register from the device. A maximum of 125 consecutive Modbus registers can be read with 1 telegram: 1 Modbus register = 2 bytes  Function codes 03 and 04 produce the same result.	Read parameters with read access and write access Example: Read volume flow
04	Read input register	Modbus master reads 1 Modbus register from the device. A maximum of 125 consecutive Modbus registers can be read with 1 telegram: 1 Modbus register = 2 bytes  Function codes 03 and 04 produce the same result.	Read parameters with read access Example: Read totalizer value
06	Write single registers	Modbus Master writes 1 new value to 1 Modbus register of the device.  Function code 16 can be used to write to multiple registers with 1 telegram.	Write only 1 parameter Example: reset the totalizer
08	Diagnostics	Modbus master checks the communication with the device. The following "Diagnostics codes" are supported: <ul style="list-style-type: none"> <li>Sub-function 00 = Return query data (loopback test)</li> <li>Sub-function 02 = Return diagnostics register</li> </ul>	

Code	Name	Description	Application
16	Write multiple registers	<p>Modbus master writes 1 new value to multiple Modbus registers of the device. A maximum of 120 consecutive Modbus registers can be written with 1 telegram.</p> <p> If the required device parameters are not available as a group, but must be addressed with a single telegram, use the Modbus data map .</p>	Write multiple parameters
23	Read/Write multiple registers	<p>Modbus master reads and writes a maximum of 118 Modbus registers of the device simultaneously with 1 telegram. Write access is executed before read access.</p>	<p>Read and write multiple parameters</p> <p>Example:</p> <ul style="list-style-type: none"> <li>Read mass flow</li> <li>Reset the totalizer</li> </ul>

 Broadcast messages are allowed with function codes 06, 16 and 23.

### Modbus register information

 Overview of parameters with the Modbus register information: Description of Parameters →  6.

### Response time

Response time of the device to the telegram of the Modbus master: typically 3 to 5 ms.

### Data types

<p><b>FLOAT</b></p> <ul style="list-style-type: none"> <li>Floating point numbers IEEE 754</li> <li>Data length = 4 bytes (2 registers)</li> </ul>	<p>Byte 3</p> <p>SEEEEEEE</p>	<p>Byte 2</p> <p>EMMMMMMM</p>	<p>Byte 1</p> <p>MMMMMMMM</p>	<p>Byte 0</p> <p>MMMMMMMM</p>	
<p>S = sign, E = exponent, M = mantissa</p>					
<p><b>INTEGER</b></p> <p>Data length = 2 bytes (1 register)</p>	<p>Byte 1</p> <p>Most significant byte (MSB)</p>		<p>Byte 0</p> <p>Least significant byte (LSB)</p>		
<p><b>STRING</b></p> <ul style="list-style-type: none"> <li>Data length = depends on parameter</li> <li>Example of a parameter with a data length = 18 bytes (9 registers)</li> </ul>	<p>Byte 17</p> <p>Most significant byte (MSB)</p>	<p>Byte 16</p>	<p>...</p>	<p>Byte 1</p>	<p>Byte 0</p> <p>Least significant byte (LSB)</p>

### Byte sequence

Byte addressing (the byte sequence) is not specified in the Modbus specification. During commissioning, it is necessary to configure the addressing between the master and slave with the **"Byte order" parameter**.

The bytes are transmitted depending on the selection in the **"Byte order" parameter**.

FLOAT	Selection	Byte sequence			
		1.	2.	3.	4.
	1 - 0 - 3 - 2 *	Byte 1 (MMMMMMMM)	Byte 0 (MMMMMMMM)	Byte 3 (SEEEEEEE)	Byte 2 (EMMMMMMM)
	0 - 1 - 2 - 3	Byte 0 (MMMMMMMM)	Byte 1 (MMMMMMMM)	Byte 2 (EMMMMMMM)	Byte 3 (SEEEEEEE)
	2 - 3 - 0 - 1	Byte 2 (EMMMMMMM)	Byte 3 (SEEEEEEE)	Byte 0 (MMMMMMMM)	Byte 1 (MMMMMMMM)
	3 - 2 - 1 - 0	Byte 3 (SEEEEEEE)	Byte 2 (EMMMMMMM)	Byte 1 (MMMMMMMM)	Byte 0 (MMMMMMMM)

\* = factory setting, S = sign, E = exponent, M = mantissa

INTEGER	Selection	Byte sequence	
		1.	2.
	1 - 0 - 3 - 2 *	Byte 1 (MSB)	Byte 0 (LSB)
	3 - 2 - 1 - 0	Byte 0 (LSB)	Byte 1 (MSB)

\* = factory setting, MSB = most significant byte, LSB = least significant byte

STRING	Selection	Byte sequence				
		1.	2.	...	17.	18.
Example of a parameter with a data length = 18 bytes (9 registers)	1 - 0 - 3 - 2 *	Byte 17 (MSB)	Byte 16	...	Byte 1	Byte 0 (LSB)
	3 - 2 - 1 - 0	Byte 16	Byte 17 (MSB)	...	Byte 0 (LSB)	Byte 1

\* = factory setting, MSB = most significant byte, LSB = least significant byte

## Modbus data map

### Function of the Modbus data map

The device offers a special memory area, the Modbus data map (for a maximum of 16 parameters), so that the calling of parameters via Modbus RS485 is no longer limited to individual parameters or a group of consecutive parameters.

Parameters can be grouped flexibly. The Modbus master can read and write to the entire data block via a single telegram.

### Structure of the Modbus data map

The Modbus data map consists of two data sets:

- Scan list: Configuration area  
The parameters to be grouped are defined in a scan list by entering their Modbus register addresses in the scan list.
- Data area  
The device cyclically reads out the Modbus register addresses entered in the scan list and writes the associated values for the parameters to the data area.

 Overview of parameters with the Modbus register information: Description of Parameters →  6.

### Scan list configuration

For configuration, the Modbus register addresses of the parameters to be grouped must be entered in the scan list. Please note the following basic requirements of the scan list:

<b>Max. entries</b>	16 parameters
<b>Supported parameters</b>	Only parameters with the following characteristics are supported: <ul style="list-style-type: none"> <li>▪ Access type: read access or write access</li> <li>▪ Data type: float or integer</li> </ul>

### Configuration of the scan list via the local display or the SmartBlue App

The scan list is configured with FieldCare or DeviceCare via the **Scan list register 0 to 15** parameter.

#### Navigation

Application → Communication → Modbus data map → Scan list register 0 to 15

No.	Configuration register
0	Scan list register 0
...	...
15	Scan list register 15

### Configuration of the scan list via Modbus RS485

The scan list is configured via Modbus register addresses 5001 to 5016

No.	Modbus register address	Data type	Configuration register
0	5001	Integer	Scan list register 0
...	...	Integer	...
15	5016	Integer	Scan list register 15

### Reading out data via Modbus RS485

- Values for the parameters have been defined in the scan list.
- To read out the values, the Modbus master accesses the data area of the Modbus data map.
- Modbus master access to the data area via Modbus register addresses 5051 to 5081.

Parameter value	Modbus register addresses		Data type <sup>1)</sup>	Access <sup>2)</sup>
	Start register	End register (Float only)		
Value of scan list register 0	5051	5052	Integer/float	Read/write
Value of scan list register 1	5053	5054	Integer/float	Read/write
Value of scan list register ...	...	...	...	...
Value of scan list register 15	5081	5082	Integer/float	Read/write

1) The data type depends on the parameter entered in the scan list.

2) The data access depends on the parameter entered in the scan list. If the parameter entered supports read access and write access, the parameter can be accessed via the data area.







## 8 Commissioning

---

Post-installation check and post-connection check	66
IT security	66
Device-specific IT security	66
Switching on the device	67
Commissioning the device	68

## Post-installation check and post-connection check

Before commissioning the device, make sure that the post-installation and post-connection checks have been performed:

- Post-installation check → *Post-installation check*,  36
- Post-connection check → *Post-connection check*,  49

## IT security

We only provide a warranty if the device is installed and used as described in the Operating Instructions. The device is equipped with security mechanisms to protect it against any inadvertent changes to the device settings.

IT security measures in line with operators' security standards and designed to provide additional protection for the device and device data transfer must be implemented by the operators themselves.

## Device-specific IT security

### Access via Bluetooth

Secure signal transmission via Bluetooth uses an encryption method tested by the Fraunhofer Institute.

- Without the SmartBlue App, the device is not visible via Bluetooth.
- Only one point-to-point connection is established between the device and a smartphone or tablet.

### Access via the SmartBlue App

Two access levels (user roles) are defined for the device: the **Operator** user role and the **Maintenance** user role. The **Maintenance** user role is configured when the device leaves the factory.

If a user-specific access code is not defined (in the Enter access code parameter), the default setting **0000** continues to apply and the **Maintenance** user role is automatically enabled. The device's configuration data are not write-protected and can be edited at all times.

If a user-specific access code has been defined (in the Enter access code parameter), all the parameters are write-protected. The device is accessed with the **Operator** user role. When the user-specific access code is entered a second time, the **Maintenance** user role is enabled. All parameters can be written to.



For detailed information, see the "Description of Device Parameters" document pertaining to the device.

### Protecting access via a password

There are a variety of ways to protect against write access to the device parameters:

- User-specific access code:  
Protect write access to the device parameters via all the interfaces.
- Bluetooth key:  
The password protects access and the connection between an operating unit, e.g. a smartphone or tablet, and the device via the Bluetooth interface.

### General notes on the use of passwords

- The access code and Bluetooth key that are valid when the device is delivered must be redefined during commissioning.
- Follow the general rules for generating a secure password when defining and managing the access code and Bluetooth key.
- The user is responsible for the management and careful handling of the access code and Bluetooth key.



### Write protection switch

The entire operating menu can be locked via the write protection switch. The values of the parameters cannot be changed. Write protection is disabled when the device leaves the factory.

Access authorization with write protection:

- Disabled: write access to the parameters
- Enabled: read-only access to the parameters

Write protection is enabled with the write protection switch on the back of the display module → *Hardware settings*,  48.



 The local display indicates that write protection is enabled on the top right of the display: .

### Switching on the device

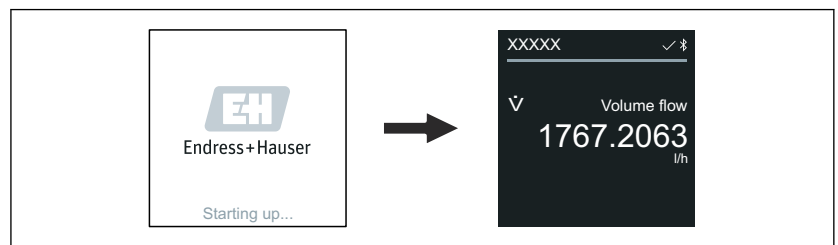
- ▶ Switch on the supply voltage for the device.
  - ↳ The local display switches from the start screen to the operational display.



A0042938

 If device startup is not successful, the device displays an error message to this effect → *Diagnosis and troubleshooting*,  74.

## Commissioning the device

### Local operation

 Detailed information on local operation: → *Operation*,  52

1. Via the "Menu" symbol, open the main menu.

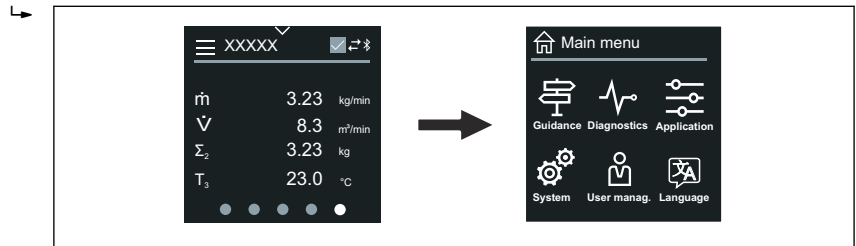

A0042939

2. Via the "Language" symbol, select the desired language.

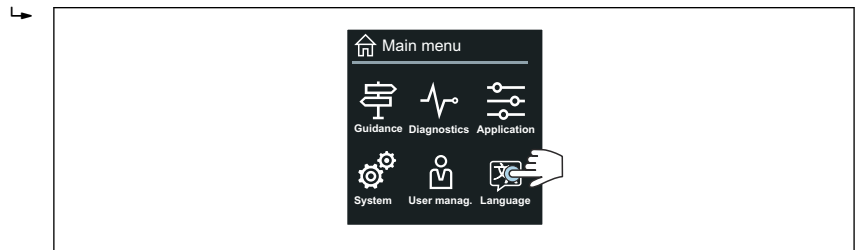

A0042940

3. Via the "Guidance" symbol, open the **Commissioning** wizard.

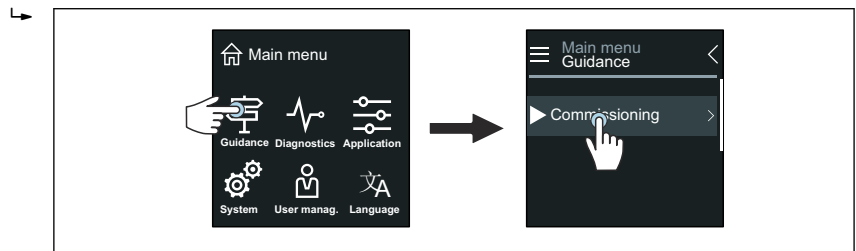

A0042941

4. Start the **Commissioning** wizard.

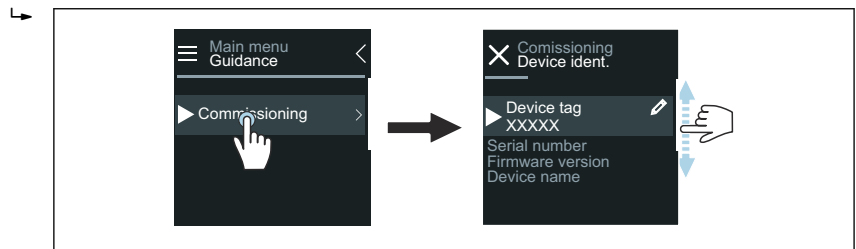

A0043018

5. Follow the instructions on the local display.

↳ The **Commissioning** wizard goes through all the device parameters that are necessary to commission the device.

 For detailed information, see the "Description of Device Parameters" document pertaining to the device.

### SmartBlue App

 Information on the SmartBlue App .

### Connecting the SmartBlue App to the device

1. Enable Bluetooth on the mobile handheld terminal, tablet or smartphone.
2. Start the SmartBlue App.
  - ↳ A Live List shows all the devices available.
3. Select the desired device.
  - ↳ The SmartBlue App shows the device login.
4. Under user name, enter **admin**.
5. Under password, enter the device's serial number. Serial number:  
→ *Transmitter nameplate*, 📄 17.
6. Confirm your entries.
  - ↳ The SmartBlue App connects to the device and displays the main menu.

### Opening "Commissioning" wizard

1. Via the **Guidance** menu, open the **Commissioning** wizard.
2. Follow the instructions on the local display.
  - ↳ The **Commissioning** wizard goes through all the device parameters that are necessary to commission the device.



## 9 Operation

---

Reading off the device locking status	72
HistoROM data management	72

## Reading off the device locking status

Indicates the write protection with the highest priority that is currently active.

### Navigation

"System" menu → Device management → Locking status

### Parameter overview with brief description

Parameter	Description	User interface
Locking status	Indicates the write protection with the highest priority that is currently active.	<ul style="list-style-type: none"> <li>▪ Hardware locked</li> <li>▪ Temporarily locked</li> </ul>

## HistoROM data management

The device features HistoROM data management. Device data and process data can be saved, imported and exported with the HistoROM data management function, making operation and servicing far more reliable, secure and efficient.

### Data backup

#### Automatically

The most important device data, e.g. sensor and transmitter, are automatically saved in the S+T-DAT.

Following replacement of the sensor, the customer-specific sensor data are transferred to the device. The device goes into operation immediately without any problems.

#### Manual

The transmitter data (customer settings) must be manually saved.

### Storage concept

	HistoROM backup	S+T-DAT
Available data	<ul style="list-style-type: none"> <li>▪ Event logbook, e.g. Diagnostic events</li> <li>▪ Parameter data record backup</li> </ul>	<ul style="list-style-type: none"> <li>▪ Sensor data, e.g. Nominal diameter</li> <li>▪ Serial number</li> <li>▪ Calibration data</li> <li>▪ Configuration of the device, e.g. software options</li> </ul>
Storage location	On the sensor electronics module (ISEM)	In the sensor connector in the sensor neck

### Data transmission

A parameter configuration can be transferred to another device using the export function of the operating tool. The parameter configuration can be duplicated or saved in an archive.



## 10 Diagnosis and troubleshooting

---

General troubleshooting	74
Diagnostic information via LED	75
Diagnostic information on local display	77
Diagnostic information in FieldCare or DeviceCare	78
Changing the diagnostic information	79
Overview of diagnostic information	79
Pending diagnostic events	82
Diagnostic list	82
Event logbook	83
Resetting the device	84

## General troubleshooting

### Local display

Fault	Possible causes	Remedy
Local display dark, no output signals	Supply voltage does not match the voltage specified on the nameplate. Supply voltage has incorrect polarity. No contact between cables and terminals. Terminals are not plugged into the electronics module correctly. Electronics module is defective.	Apply the correct supply voltage. Reverse polarity of supply voltage. <ul style="list-style-type: none"> <li>■ Check contact of cables.</li> <li>■ Connect the cables to the terminals again.</li> <li>■ Check the terminals.</li> <li>■ Plug the terminals into the electronics module again.</li> </ul> Order the appropriate spare part.
Local display is dark, but signal output is within the valid range.	Incorrect contrast setting of local display. Cable connector for the local display is not correctly connected. Local display is defective.	Adjust the contrast of the local display to ambient conditions. Plug in the cable connector correctly. Order the appropriate spare part.
Display alternates between error message and operational display	Diagnostic event has occurred.	Carry out appropriate troubleshooting measures.
Local display shows text in a foreign, incomprehensible language.	A foreign language is set.	Set the language of the local display.

#### Only for remote version

Fault	Possible causes	Remedy
Local display displays a fault, no output signals	Cable connectors between the electronics module and local display are not plugged in correctly. Electrode cable and coil current cable are not plugged in correctly.	Plug in the cable connector correctly. Plug in the electrode cable and coil current cable correctly.

### Output signal

Fault	Possible causes	Remedy
Signal output is outside the valid current range (< 3.5 mA or > 23 mA).	Electronics module is defective.	Order the appropriate spare part.
Local display shows the correct value, but signal output is incorrect, though in the valid range.	Parameter configuration error	<ul style="list-style-type: none"> <li>■ Check parameter configuration.</li> <li>■ Correct parameter configuration.</li> </ul>
Device is measuring incorrectly.	<ul style="list-style-type: none"> <li>■ Parameter configuration error</li> <li>■ The device is being operated outside the application range.</li> </ul>	<ul style="list-style-type: none"> <li>■ Check parameter configuration.</li> <li>■ Correct parameter configuration.</li> <li>■ Observe limit values indicated.</li> </ul>
No signal at frequency output	Device uses passive frequency output.	Wire the device correctly as described in the Operating Instructions .

### Access and communication

Fault	Possible causes	Remedy
Not possible to write-access the parameter.	Write protection is enabled.	Set the write protection switch on the local display to the <b>Off</b> position.
	Current user role has limited access authorization.	<ol style="list-style-type: none"> <li>1. Check user role.</li> <li>2. Enter correct customer-specific access code.</li> </ol>
Modbus communication is not possible.	Modbus RS485 bus cable is connected incorrectly.	Check the terminal assignment.
	Modbus RS485 cable is incorrectly terminated.	Check terminating resistor .
Device communication is not possible.	Settings for the communication interface are incorrect. Data transfer is active.	Check the Modbus RS485 configuration. Wait until the data transfer or the current action is finished.
SmartBlue App does not show the device in the live list.	<ul style="list-style-type: none"> <li>▪ Bluetooth is disabled on the device.</li> <li>▪ Bluetooth is disabled on the smartphone or tablet.</li> </ul>	<ol style="list-style-type: none"> <li>1. Check whether the Bluetooth symbol appears on the local display.</li> <li>2. Enable Bluetooth on the device.</li> <li>3. Enable Bluetooth on the smartphone or tablet.</li> </ol>
Device cannot be operated with the SmartBlue App.	<ul style="list-style-type: none"> <li>▪ Bluetooth connection is not available.</li> <li>▪ The device is already connected to another smartphone or tablet.</li> <li>▪ Incorrect password entered.</li> <li>▪ Password forgotten.</li> </ul>	<ol style="list-style-type: none"> <li>1. Check whether other devices are connected to the SmartBlue App.</li> <li>2. Disconnect any other device connected to the SmartBlue App.</li> <li>1. Enter correct password.</li> <li>2. Contact Endress+Hauser service organization.</li> </ol>
Login with user data is not possible with the SmartBlue App.	Device in operation for the first time.	<ol style="list-style-type: none"> <li>1. Enter the initial password (serial number of the device).</li> <li>2. Change the initial password.</li> </ol>

### Diagnostic information via LED

Only for devices with the order code for "Display; operation", option H

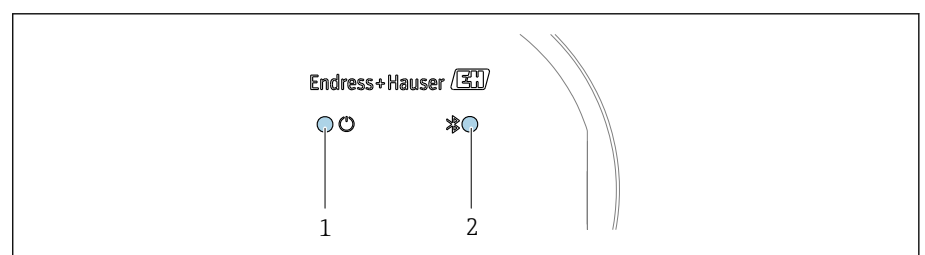

- 1 Device status
- 2 Bluetooth

A0044231

LED	Status	Meaning
1 Device status (normal operation)	Off	No power supply
	Permanently green	Device status is OK. No warning / failure / alarm
	Flashing red	Warning is active.
	Permanently red	Alarm is active.
2 Bluetooth	Off	Bluetooth is disabled.
	Permanently blue	Bluetooth is enabled.
	Flashing blue	Data transfer in progress.

## Diagnostic information on local display

### Diagnostic message

The local display alternates between displaying faults as a diagnostic message and displaying the operational display screen.

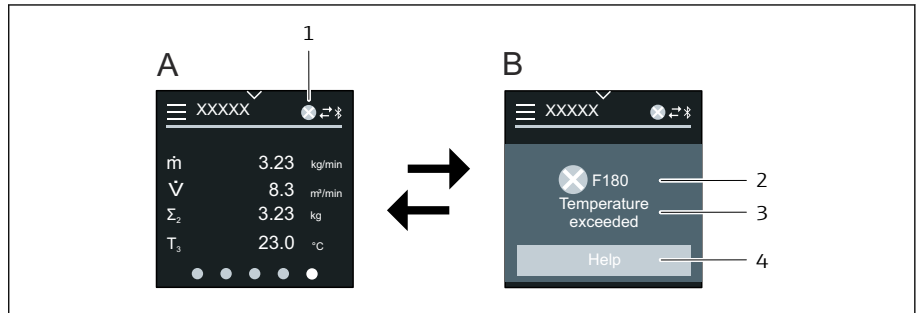

A0042937

- A Operational display in alarm condition  
 B Diagnostic message  
 1 Diagnostic behavior  
 2 Diagnostic behavior with diagnostic code  
 3 Short text  
 4 Open information on remedial measures (HART and Modbus RS485 only)

If two or more diagnostic events are pending simultaneously, the local display only shows the diagnostic message with the highest priority.



Other diagnostic events that have occurred can be opened in the **Diagnostics** menu as follows:

- Via parameters
- Via submenus

### Status signals

The status signals provide information on the state and reliability of the device by categorizing the cause of the diagnostic information (diagnostic event).



The status signals are categorized according to NAMUR Recommendation NE 107: F = Failure, C = Function Check, S = Out of Specification, M = Maintenance Required, N = No Effect



A0013956

#### Failure

- A device error has occurred.
- Measured value is no longer valid.

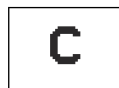

A0013959

#### Function check

Device is in the service mode, e.g. during a simulation.

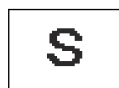

A0013958

#### Out of specification

Device is being operated outside the technical specification limits, e.g. outside the process temperature range.



A0013957

#### Maintenance required

- Maintenance is required.
- Measured value is still valid.

### Diagnostic information

The fault can be identified using the diagnostic information. The short text displays a tip about the fault.

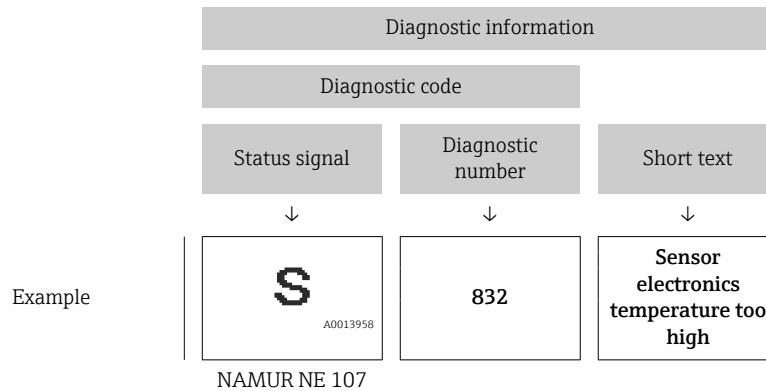

### Diagnostic information in FieldCare or DeviceCare

#### Diagnostic options

After the connection has been established, the device shows faults on the home page.

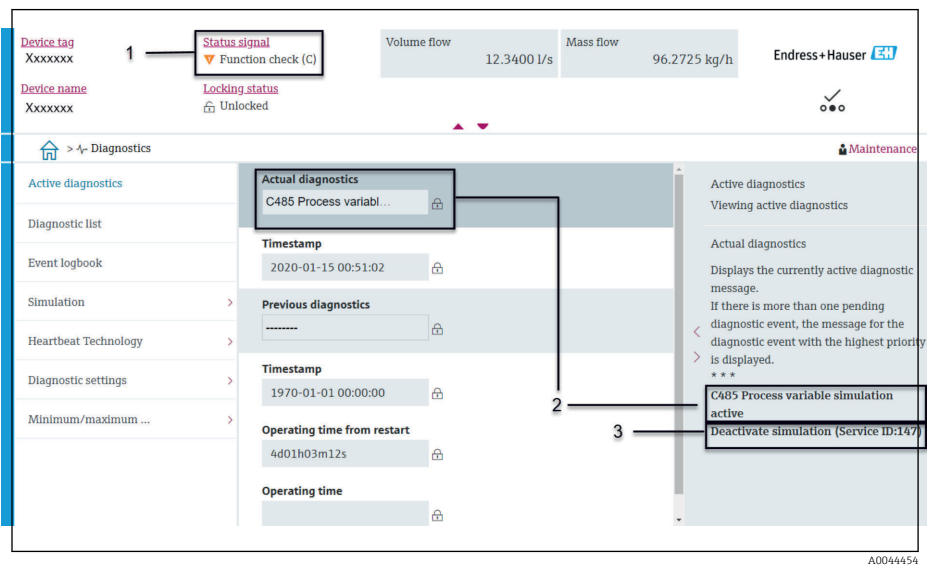

- 1 Status area with diagnostic behavior and status signal
- 2 Diagnostic code and short message
- 3 Troubleshooting measures with service ID

- i** Other diagnostic events that have occurred can be opened in the **Diagnostics** menu as follows:
  - Via parameter
  - Via submenus

### Diagnostic information

The fault can be identified using the diagnostic information. The short text displays a tip about the fault. The corresponding symbol for the diagnostic behavior appears at the start.

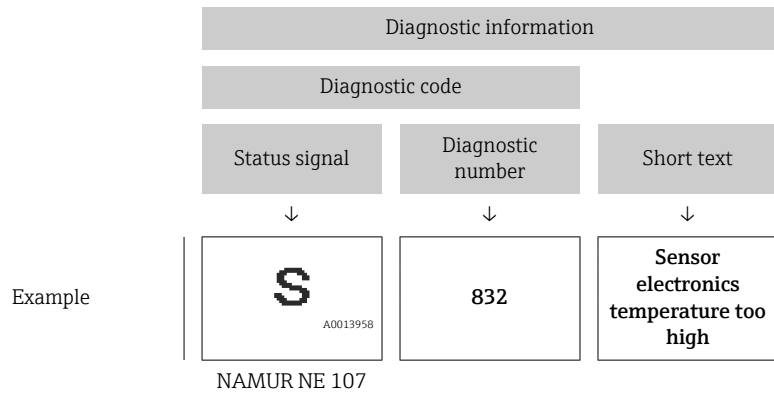

## Changing the diagnostic information

### Adapting the diagnostic behavior

Each item of diagnostic information is assigned a specific diagnostic behavior at the factory. The user can change the assignment for specific diagnostic information in the **Diagnostic settings** submenu.

#### Navigation path

Diagnostics → Diagnostic settings

You can assign the following options to the diagnostic number as the diagnostic behavior:

Options	Description
Alarm	<ul style="list-style-type: none"> <li>Device stops measurement.</li> <li>Signal outputs and totalizers assume a defined alarm condition.</li> <li>Diagnostic message is generated.</li> </ul>
Warning	<ul style="list-style-type: none"> <li>Device stops measurement.</li> <li>Measured value output via Modbus RS485 and totalizers assume a defined alarm condition.</li> <li>Diagnostic message is generated.</li> </ul>
Logbook entry only	<ul style="list-style-type: none"> <li>Device continues measuring.</li> <li>The local display shows the diagnostic message in the <b>Event logbook</b> submenu (<b>Event list</b> submenu) and does not alternate with the operational display.</li> </ul>
Off	<ul style="list-style-type: none"> <li>Diagnostic event is ignored.</li> <li>Diagnostic message is not generated and not entered.</li> </ul>

## Overview of diagnostic information

**i** The amount of diagnostic information and the number of measured variables affected increase if the device has one or more application packages.

Diagnostic number	Short text	Remedy instructions	Status signal [from the factory]	Diagnostic behavior [from the factory]
<b>Diagnostic of sensor</b>				
043	Sensor 1 short circuit detected	1. Check sensor cable and sensor 2. Execute Heartbeat Verification 3. Replace sensor cable or sensor	S	Warning <sup>1)</sup>
082	Data storage inconsistent	1. Check module connections 2. Contact service	F	Alarm
083	Memory content inconsistent	1. Restart device 2. Restore HistoROM S-DAT backup ('Device reset' parameter) 3. Replace HistoROM S-DAT	F	Alarm
168	Build-up detected	Clean measuring tube	M	Warning
169	Conductivity measurement failed	1. Check grounding conditions 2. Deactivate conductivity measurement	M	Warning
170	Coil resistance faulty	Check ambient and process temperature	F	Alarm
180	Temperature sensor defective	1. Check sensor connections 2. Replace sensor cable or sensor 3. Turn off temperature measurement	F	Warning
181	Sensor connection faulty	1. Check sensor cable and sensor 2. Execute Heartbeat Verification 3. Replace sensor cable or sensor	F	Alarm
<b>Diagnostic of electronic</b>				
201	Electronics faulty	1. Restart device 2. Replace electronics	F	Alarm
230	Date/time incorrect	1. Replace RTC buffer battery 2. Set date and time	M	Warning <sup>1)</sup>
231	Date/time not available	1. Replace display module or its cable 2. Set date and time	M	Warning <sup>1)</sup>
242	Firmware incompatible	1. Check firmware version 2. Flash or replace electronic module	F	Alarm
252	Module incompatible	1. Check electronic modules 2. Check if correct modules are available (e.g. NEx, Ex) 3. Replace electronic modules	F	Alarm
278	Display module defective	Replace display module	F	Alarm
283	Memory content inconsistent	1. Reset device 2. Contact service	F	Alarm
302	Device verification active	Device verification active, please wait.	C	Warning <sup>1)</sup>
311	Sensor electronics (ISEM) faulty	1. Do not reset device 2. Contact service	M	Warning



Diagnostic number	Short text	Remedy instructions	Status signal [from the factory]	Diagnostic behavior [from the factory]
331	Firmware update failed in module 1 to n	1. Update firmware of device 2. Restart device	F	Warning
372	Sensor electronics (ISEM) faulty	1. Restart device 2. Check if failure recurs 3. Replace sensor electronic module (ISEM)	F	Alarm
373	Sensor electronics (ISEM) faulty	Contact service	F	Alarm
376	Electronic module faulty	1. Replace electronic module 2. Turn off diagnostic message	S	Warning <sup>1)</sup>
377	Electronic module faulty	1. Activate empty pipe detection 2. Check partial filled pipe and installation direction 3. Check sensor cabling 4. Deactivate diagnostics 377	S	Warning <sup>1)</sup>
378	Electronic module supply voltage faulty	1. Restart device 2. Check if failure recurs 3. Replace electronic module	F	Alarm
383	Memory content	1. Restart device 2. Delete T-DAT via 'Reset device' parameter 3. Replace T-DAT	F	Alarm
387	HistoROM data faulty	Contact service organization	F	Alarm
<b>Diagnostic of configuration</b>				
410	Data transfer failed	1. Check connection 2. Retry data transfer	F	Alarm
412	Processing download	Download active, please wait	C	Warning
431	Trim 1 required	Carry out trim	C	Warning
437	Configuration incompatible	1. Restart device 2. Contact service	F	Alarm
438	Dataset different	1. Check data set file 2. Check device configuration 3. Up- and download new configuration	M	Warning
441	Current output faulty	1. Check process 2. Check current output settings	S	Warning <sup>1)</sup>
453	Flow override active	Deactivate flow override	C	Warning
484	Failure mode simulation active	Deactivate simulation	C	Alarm
485	Process variable simulation active	Deactivate simulation	C	Warning
491	Current output 1 simulation active	Deactivate simulation	C	Warning
495	Diagnostic event simulation active	Deactivate simulation	C	Warning
511	Electronic module settings faulty	1. Check measuring period and integration time 2. Check sensor properties	C	Alarm

Diagnostic number	Short text	Remedy instructions	Status signal [from the factory]	Diagnostic behavior [from the factory]
<b>Diagnostic of process</b>				
832	Sensor electronics temperature too high	Reduce ambient temperature	S	Warning <sup>1)</sup>
833	Sensor electronics temperature too low	Increase ambient temperature	S	Warning <sup>1)</sup>
834	Process temperature too high	Reduce process temperature	S	Warning <sup>1)</sup>
835	Process temperature too low	Increase process temperature	S	Warning <sup>1)</sup>
842	Process value above limit	Low flow cut off active! 1. Check low flow cut off configuration	S	Warning <sup>1)</sup>
937	Sensor symmetry	1. Eliminate external magnetic field near sensor 2. Turn off diagnostic message	S	Warning <sup>1)</sup>
938	EMC interference	1. Check ambient conditions regarding EMC influence 2. Turn off diagnostic message	F	Alarm <sup>1)</sup>
944	Monitoring failed	Check process conditions for Heartbeat Monitoring	S	Warning
961	Electrode potential out of specification	1. Check process conditions 2. Check ambient conditions	S	Warning <sup>1)</sup>
962	Pipe empty	1. Perform full pipe adjustment 2. Perform empty pipe adjustment 3. Turn off empty pipe detection	S	Warning <sup>1)</sup>

1) Diagnostic behavior can be changed.

## Pending diagnostic events

The **Active diagnostics** submenu displays the current diagnostic event and the last diagnostic event to occur.

Diagnostics → Active diagnostics



The **Diagnostic list** submenu shows other diagnostic events that are pending.

## Diagnostic list

The **Diagnostic list** submenu shows up to 5 currently pending diagnostic events with the related diagnostic information. If more than 5 diagnostic events are pending, the local display shows the diagnostic information with the highest priority.

### Navigation path

Diagnostics → Diagnostic list

## Event logbook

### Reading out the event logbook

 The event logbook is only available via FieldCare, DeviceCare or SmartBlue App (Bluetooth).



The **Event logbook** submenu shows a chronological overview of the event messages that have occurred.

#### Navigation path



**Diagnostics** menu → **Event logbook** submenu

Chronological display with a maximum of 20 event messages.

The event history includes the following entries:

- Diagnostic event → *Overview of diagnostic information*,  79
- Information event → *Overview of information events*,  83

In addition to the operation time of the event occurrence, each event is also assigned a symbol that indicates whether the event has occurred or has ended:

- Diagnostic event
  - : Occurrence of the event
  - : End of the event
- Information event
  - : Occurrence of the event

 Filter event messages:

### Filtering the event logbook

The **Event logbook** submenu displays the category of event messages that were configured with the **Filter options** parameter.

#### Navigation path

Diagnostics → Event logbook → Filter options

#### Filter categories

- All
- Failure (F)
- Function check (C)
- Out of specification (S)
- Maintenance required (M)
- Information (I)

### Overview of information events

The information event is only displayed in the event logbook.

Info number	Info name
I1000	----- (Device ok)
I1079	Sensor changed
I1089	Power on
I1090	Configuration reset
I1091	Configuration changed
I11036	Date/time set successfully
I11167	Date/time resynchronized
I1137	Display module replaced
I1151	History reset

Info number	Info name
I1155	Sensor electronics temperature reset
I1157	Memory error event list
I1256	Display: access status changed
I1335	Firmware changed
I1351	Empty pipe detection adjustment failure
I1353	Empty pipe detection adjustment ok
I1397	Fieldbus: access status changed
I1398	CDI: access status changed
I1443	Build-up thickness not determined
I1444	Device verification passed
I1445	Device verification failed
I1459	I/O module verification failed
I1461	Sensor verification failed
I1462	Sensor electronic module verific. failed
I1512	Download started
I1513	Download finished
I1514	Upload started
I1515	Upload finished
I1622	Calibration changed
I1624	All totalizers reset
I1625	Write protection activated
I1626	Write protection deactivated
I1629	CDI: login successful
I1632	Display: login failed
I1633	CDI: login failed
I1634	Reset to factory settings
I1635	Reset to delivery settings
I1649	Hardware write protection activated
I1650	Hardware write protection deactivated
I1712	New flash file received
I1725	Sensor electronic module (ISEM) changed

## Resetting the device

The entire configuration, or a part of the configuration, can be reset to a defined state here.

### Navigation path

System → Device management → Device reset

Options	Description
To delivery settings	Every parameter for which a customer-specific default setting was ordered is reset to the customer-specific value. All other parameters are reset to the factory setting.
Restart device	The restart resets every parameter with data stored in volatile memory (RAM) to the factory setting (e.g. measured value data). The device configuration remains unchanged.

Restore S-DAT backup	Restore the data that is saved on the S-DAT. The data record is restored from the electronics memory to the S-DAT. Visibility depends on order options or device settings  The local display only displays this option in an alarm condition.
Create T-DAT backup	Create T-DAT backup.
Restore T-DAT backup	Restores the data saved on the T-DAT. This function can be used to resolve the memory issue "283 Memory content inconsistent" or to restore the T-DAT data when a new T-DAT has been installed. Visibility depends on order options or device settings



# 11 Maintenance

---

Maintenance work	88
Services	88

## Maintenance work

The device is maintenance-free. Modifications or repairs may only be carried out following consultation with an Endress+Hauser service organization. It is recommended to examine the device regularly for corrosion, mechanical wear and damage.

### Cleaning of surfaces not in contact with medium

1. Recommendation: Use a dry or slightly damp lint-free cloth.
2. Do not use any sharp objects or aggressive cleaning agents that could damage surfaces (e.g. displays, housing) and seals.
3. Do not use high-pressure steam.
4. Observe the degree of protection of the device.

#### NOTICE

##### Surface damage caused by cleaning agents

Using the wrong cleaning agents can cause damage to surfaces.

- ▶ Do not use cleaning agents containing concentrated mineral acids, alkaline solutions or organic solvents e. g. benzyl alcohol, methylene chloride, xylene, concentrated glycerol cleaner or acetone.

### Cleaning of surfaces in contact with the medium

Note the following for cleaning and sterilization in place (CIP/SIP):

- Use only cleaning agents to which the materials in contact with the medium are sufficiently resistant.
- Observe the permitted maximum medium temperature.

## Services

Endress+Hauser offers a wide range of services for device maintenance, e.g. recalibration, maintenance service or device tests.

Endress+Hauser sales organizations can provide information about the services available.



# 12 Disposal

---

Removing the device	90
Disposing of the device	90

## Removing the device

1. Disconnect the device from the supply voltage.
2. Remove all connecting cables.

### **⚠ WARNING**

#### **Process conditions can put staff at risk!**

- ▶ Wear suitable protective equipment.
- ▶ Allow the device and pipe to cool.
- ▶ Empty the device and pipe so that they are unpressurized.
- ▶ Rinse the device and pipe if necessary.

3. Remove the device correctly.

## Disposing of the device

### **⚠ WARNING**

#### **Dangerous media can endanger staff and the environment!**

- ▶ Ensure that the device and all cavities are free of medium residues that are hazardous to health or the environment, e.g. substances that have permeated into crevices or diffused through plastic.



A0042336

If required by the Directive 2012/19/EU of the European Parliament and the Council of 4 July 2012 on waste electrical and electronic equipment (WEEE), the device is marked with the depicted symbol in order to minimize the disposal of WEEE as unsorted municipal waste.

- Do not dispose of devices bearing this marking as unsorted municipal waste. Instead, return them to Endress+Hauser for disposal under the applicable conditions.
- Observe applicable federal/national regulations.
- Ensure proper separation and reuse of the device components.
- Overview of installed materials: → *Materials*, 109

## 13 Technical data

---

Input	92
Output	93
Energy supply	96
Cable specification	98
Performance characteristics	100
Environment	102
Process	104
Mechanical construction	106
Local display	111
Certificates and approvals	112
Application packages	113

## Input

### Measured variable

Direct measured variables	Volume flow (proportional to induced voltage)
Calculated measured variables	Mass flow

### Operable flow range

Over 1000 : 1

### Measuring range

Typically  $v = 0.01$  to  $10$  m/s ( $0.03$  to  $33$  ft/s) with specified measuring accuracy

Electrical conductivity:

- $\geq 5$   $\mu\text{S/cm}$  for liquids in general
- $\geq 20$   $\mu\text{S/cm}$  for demineralized water

#### Flow characteristic values in SI units

Nominal diameter		Recommended flow min./max. full scale value ( $v \sim 0.3/10$ m/s)	Full scale value current output ( $v \sim 2.5$ m/s)	Factory settings	
[mm]	[in]			Pulse value ( $\sim 2$ pulse/s)	Low flow cut off ( $v \sim 0.04$ m/s)
		[dm <sup>3</sup> /min]	[dm <sup>3</sup> /min]	[dm <sup>3</sup> ]	[dm <sup>3</sup> /min]
25	1	9 to 300	75	0.5	1
40	1 ½	25 to 700	200	1.5	3
50	2	35 to 1 100	300	2.5	5
65	–	60 to 2 000	500	5	8
80	3	90 to 3 000	750	5	12
100	4	145 to 4 700	1 200	10	20

#### Flow characteristic values in US units

Nominal diameter		Recommended flow min./max. full scale value ( $v \sim 0.3/10$ m/s)	Full scale value current output ( $v \sim 2.5$ m/s)	Factory settings	
[in]	[m1m]			Pulse value ( $\sim 2$ pulse/s)	Low flow cut off ( $v \sim 0.04$ m/s)
		[gal/min]	[gal/min]	[gal]	[gal/min]
1	25	2.5 to 80	18	0.2	0.25
1 ½	40	7 to 190	50	0.5	0.75
2	50	10 to 300	75	0.5	1.25
–	65	16 to 500	130	1	2
3	80	24 to 800	200	2	2.5
4	100	40 to 1 250	300	2	4

## Output

### Output signal

#### Output versions

<b>Order code 020: output; input</b>	<b>Output version</b>
Option M	<ul style="list-style-type: none"> <li>■ Modbus RS485</li> <li>■ Current output 4 to 20 mA</li> </ul>

#### Current output 4 to 20 mA

<b>Signal mode</b>	Choose via terminal assignment: <ul style="list-style-type: none"> <li>■ Active</li> <li>■ Passive</li> </ul>
<b>Current range</b>	Can be set to: <ul style="list-style-type: none"> <li>■ 4 to 20 mA NAMUR</li> <li>■ 4 to 20 mA US</li> <li>■ 4 to 20 mA</li> <li>■ Fixed current</li> </ul>
<b>Max. output current</b>	21.5 mA
<b>Open-circuit voltage</b>	DC < 28.8 V (active)
<b>Max. input voltage</b>	DC 30 V (passive)
<b>Max. load</b>	400 Ω
<b>Resolution</b>	1 μA
<b>Damping</b>	Configurable: 0 to 999.9 s
<b>Assignable measured variables</b>	<ul style="list-style-type: none"> <li>■ Off</li> <li>■ Volume flow</li> <li>■ Mass flow</li> <li>■ Noise*</li> <li>■ Coil current shot time*</li> </ul> <p>* Visibility depends on order options or device settings</p>

#### Modbus RS485

<b>Physical interface</b>	RS485 in accordance with EIA/TIA-485 standard
---------------------------	---

### Signal on alarm

Output behavior in the event of a device alarm (failure mode)

#### Modbus RS485

<b>Failure mode</b>	Selectable: <ul style="list-style-type: none"> <li>■ NaN value instead of current value</li> <li>■ Last valid value</li> </ul>
---------------------	--

#### Current output 4 to 20 mA

<b>4 to 20 mA</b>	Selectable: <ul style="list-style-type: none"> <li>■ Min. value: 3.59 mA</li> <li>■ Max. value: 21.5 mA</li> <li>■ Freely definable value between: 3.59 to 21.5 mA</li> <li>■ Actual value</li> <li>■ Last valid value</li> </ul>
-------------------	---

### Low flow cut off

The switch points for low flow cut off are user-selectable.

### Galvanic isolation

The outputs are galvanically isolated from one another and from earth.

### Protocol-specific data

<b>Physical interface</b>	RS485 in accordance with EIA/TIA-485 standard
<b>Terminating resistor</b>	Not integrated
<b>Protocol</b>	Modbus Applications Protocol Specification V1.1
<b>Response times</b>	<ul style="list-style-type: none"> <li>■ Direct data access: typically 25 to 50 ms</li> <li>■ Auto-scan buffer (data range): typically 3 to 5 ms</li> </ul>
<b>Device type</b>	Slave
<b>Slave address range</b>	1 to 247
<b>Broadcast address range</b>	0
<b>Function codes</b>	<ul style="list-style-type: none"> <li>■ 03: Read holding register</li> <li>■ 04: Read input register</li> <li>■ 06: Write single registers</li> <li>■ 08: Diagnostics</li> <li>■ 16: Write multiple registers</li> <li>■ 23: Read/write multiple registers</li> </ul>
<b>Broadcast messages</b>	Supported by the following function codes: <ul style="list-style-type: none"> <li>■ 06: Write single registers</li> <li>■ 16: Write multiple registers</li> <li>■ 23: Read/write multiple registers</li> </ul>

<b>Supported baud rate</b>	<ul style="list-style-type: none"><li>■ 1 200 BAUD</li><li>■ 2 400 BAUD</li><li>■ 4 800 BAUD</li><li>■ 9 600 BAUD</li><li>■ 19 200 BAUD</li><li>■ 38 400 BAUD</li><li>■ 57 600 BAUD</li><li>■ 115 200 BAUD</li></ul>
<b>Data transfer mode</b>	RTU
<b>Data access</b>	Each parameter can be accessed via Modbus RS485.  For Modbus register information
<b>System integration</b>	Information on system integration . <ul style="list-style-type: none"><li>■ Modbus RS485 information</li><li>■ Function codes</li><li>■ Register information</li><li>■ Response time</li><li>■ Modbus data map</li></ul>

## Energy supply

### Terminal assignment

 The terminal assignment is documented on an adhesive label.

The following terminal assignment is available:

*Modbus RS485 and current output 4 to 20 mA (active)*

Supply voltage		Output 1				Output 2	
1 (+)	2 (-)	26 (+)	27 (-)	24 (+)	25 (-)	22 (B)	23 (A)
L/+	N/-	Current output 4 to 20 mA (active)		-		Modbus RS485	

*Modbus RS485 and current output 4 to 20 mA (passive)*

Supply voltage		Output 1				Output 2	
1 (+)	2 (-)	26 (+)	27 (-)	24 (+)	25 (-)	22 (B)	23 (A)
L/+	N/-	-		Current output 4 to 20 mA (passive)		Modbus RS485	

### Supply voltage

Order code for "Power supply"	Terminal voltage		Frequency range
Option <b>A</b> IO-Link port class A	DC 18 to 30 V <sup>1)</sup>		-
Option <b>D</b>	DC 24 V	-20 to +30 %	-
Option <b>E</b>	AC 100 to 240 V	-15 to +10 %	50/60 Hz, ±5 Hz
Option <b>I</b>	DC 24 V	-20 to +30 %	-
	AC 100 to 240 V	-15 to +10 %	50/60 Hz, ±5 Hz
Option <b>M</b> non-hazardous area	DC 24 V	-20 to +30 %	-
	AC 100 to 240 V	-15 to +10 %	50/60 Hz, ±5 Hz

1) These values are absolute minimum and maximum values. No tolerance applies. The DC power unit must be tested to ensure it meets technical safety requirements (e.g. PELV, SELV) with limited power sources (e.g. Class 2).

### Power consumption

- Transmitter:  
HART, Modbus RS485: Max. 10 W (active power)
- Switch-on current:  
HART, Modbus RS485: Max. 36 A (< 5 ms) as per NAMUR Recommendation NE 21

### Current consumption

- Max. 400 mA (24 V)
- Max. 200 mA (110 V, 50/60 Hz; 230 V, 50/60 Hz)



### Power supply failure

- Totalizers stop at the last value measured.
- Device configuration remains unchanged.
- Error messages (incl. total operated hours) are stored.

### Terminals

Spring terminals

- Suitable for strands and strands with ferrules.
- Conductor cross-section 0.2 to 2.5 mm<sup>2</sup> (24 to 12 AWG).

### Cable entries

- Cable gland: M20 × 1.5 for cable Ø6 to 12 mm (0.24 to 0.47 in)
- Thread for cable entry:
  - NPT ½"
  - G ½", G ½" Ex d
  - M20

### Overvoltage protection

<b>Mains voltage fluctuations</b>	→ <i>Supply voltage</i> , 96
<b>Overvoltage category</b>	Overvoltage category II
<b>Short-term, temporary overvoltage</b>	Between cable and neutral conductor up to 1200 V for max. 5s
<b>Long-term, temporary overvoltage</b>	Up to 500 V between cable and ground

## Cable specification

### Requirements for connecting cable

#### Electrical safety

As per applicable national regulations.

#### Permitted temperature range

- Observe the installation guidelines that apply in the country of installation.
- The cables must be suitable for the minimum temperatures and maximum temperatures to be expected.

#### Power supply cable (incl. conductor for the inner ground terminal)

- A standard installation cable is sufficient.
- Provide grounding according to applicable national codes and regulations.

#### Signal cable

- Modbus RS485:  
Cable type A according to EIA/TIA-485 standard is recommended
- Current output 4 to 20 mA:  
Standard installation cable

#### Ground cable requirements

Copper wire: at least 6 mm<sup>2</sup> (0.0093 in<sup>2</sup>)

#### Connecting cable requirements

-  Connecting cable only necessary for remote version.

Electrode cable	Coil current cable
<p style="text-align: right; font-size: small;">A0054679</p> <p>1 GND (green): Ground-wire 0.38 mm<sup>2</sup> (AWG 21)</p> <p>2 E1 (brown): "Electrode E1"- core 0.38 mm<sup>2</sup> (AWG 21)</p> <p>3 E (yellow): grounding 0.38 mm<sup>2</sup> (AWG 21)</p> <p>4 E2 (white): "Electrode E2"- core 0.38 mm<sup>2</sup> (AWG 21)</p> <p>a Outer jacket</p> <p>b Cable shield</p> <p>c Core jacket</p> <p>d Core shield</p> <p>e Core insulation</p> <p>f Core</p>	<p style="text-align: right; font-size: small;">A0054680</p> <p>1 ER+ (black): coil current core 0.75 mm<sup>2</sup> (AWG 18)</p> <p>2 ER- (black): coil current core 0.75 mm<sup>2</sup> (AWG 18)</p> <p>3 NC (yellow-green): not connected 0.75 mm<sup>2</sup> (AWG 18)</p> <p>a Outer jacket</p> <p>b Cable shield</p> <p>c Core insulation</p> <p>d Core</p> <p>e Core reinforcement</p>

**i** Armored connecting cable

Armored connecting cables with additional, metal reinforcing braid can be ordered from Endress+Hauser. Armored connecting cables are used:

- When laying the cable directly in the ground
- Where there is a risk of damage from rodents
- If using the device below IP68 degree of protection

**Electrode cable**

<b>Design</b>	3×0.38 mm <sup>2</sup> (21 AWG) with common, braided copper shield (∅ ~ 9.5 mm (0.37 in)) and individual shielded cores
<b>Conductor resistance</b>	≤ 50 Ω/km (0.015 Ω/ft)
<b>Capacitance: core/shield</b>	≤ 420 pF/m (128 pF/ft)
<b>Cable length</b>	Depends on the medium conductivity: maximum 200 m (656 ft)
<b>Cable lengths (available for order)</b>	5 m (15 ft), 10 m (30 ft), 20 m (60 ft) or variable length: maximum 200 m (656 ft) Armored cables: variable length up to maximum 200 m (656 ft)
<b>Operating temperature</b>	-20 to +80 °C (-4 to +176 °F)

**Coil current cable**

<b>Design</b>	3×0.75 mm <sup>2</sup> (18 AWG) with common, braided copper shield (∅ ~ 9.5 mm (0.37 in)) and individual shielded cores
<b>Conductor resistance</b>	≤ 37 Ω/km (0.011 Ω/ft)
<b>Capacitance: core/shield</b>	≤ 120 pF/m (37 pF/ft)
<b>Cable length</b>	Depends on the medium conductivity, max. 200 m (656 ft)
<b>Cable lengths (available for order)</b>	5 m (15 ft), 10 m (30 ft), 20 m (60 ft) or variable length up to max. 200 m (656 ft) Armored cables: variable length up to max. 200 m (656 ft)

<b>Operating temperature</b>	-20 to +80 °C (-4 to +176 °F)
<b>Test voltage for cable insulation</b>	≤ AC 1 433 V rms 50/60 Hz or ≥ DC 2 026 V

## Performance characteristics

### Reference operating conditions

- Error limits based on ISO 20456:2017
- Water, typically: +15 to +45 °C (+59 to +113 °F); 0.5 to 7 bar (73 to 101 psi)
- Data as indicated in the calibration protocol
- Accuracy based on accredited calibration rigs according to ISO 17025

**i** To obtain measured errors, use the *Applicator* sizing tool → *Service-specific accessory*, 139

### Maximum measurement error

o. r. = of reading

### Error limits under reference operating conditions

#### Volume flow

±0.5 % o. r. ±1 mm/s (±0.04 in/s)

**i** Fluctuations in the supply voltage do not have any effect within the specified range.

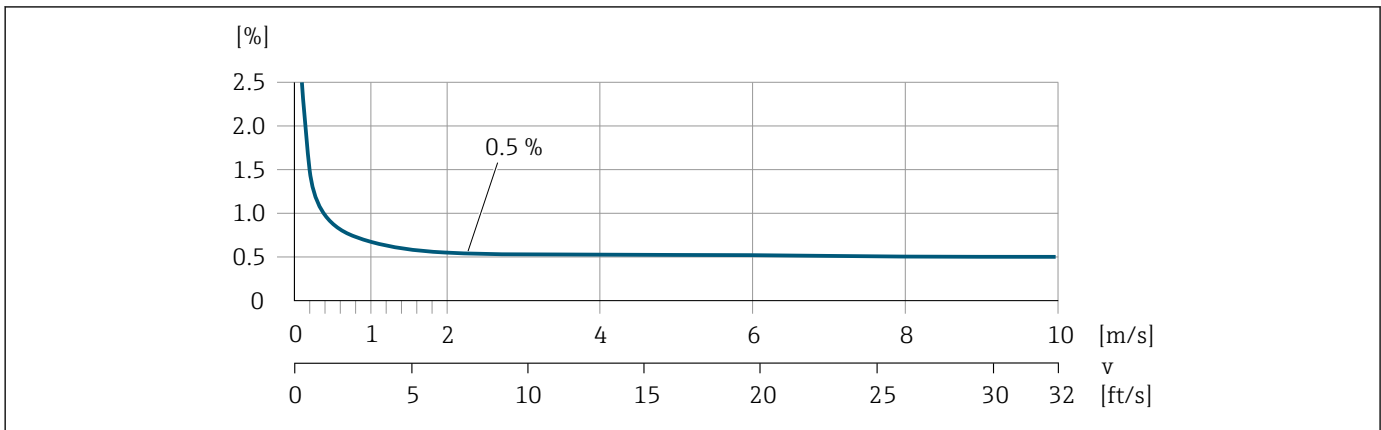

A0032055

### Accuracy of outputs

<b>Current output</b>	±5 µA
<b>Pulse/frequency output</b>	Max. ±100 ppm o. r. (across the entire ambient temperature range)

### Repeatability

<b>Volume flow</b>	Max. ±0.1 % o. r. ± 0.5 mm/s (0.02 in/s)
--------------------	--

### Influence of ambient temperature

<b>Current output</b>	Temperature coefficient max. 1 $\mu\text{A}/^\circ\text{C}$
<b>Pulse/frequency output</b>	No additional effect. Is included in the accuracy.

## Environment

### Ambient temperature range

<b>Transmitter</b>	-40 to +60 °C (-40 to +140 °F)
<b>Local display</b>	-20 to +60 °C (-4 to +140 °F) The readability of the display may be impaired at temperatures outside the temperature range.
<b>Sensor</b>	-20 to +60 °C (-4 to +140 °F)
<b>Liner</b>	Do not exceed or fall below the permitted temperature range of the liner → <i>Medium temperature range</i> , ☰ 104..

**i** Dependency of ambient temperature on medium temperature → *Medium temperature range*, ☰ 104

### Storage temperature

The storage temperature corresponds to the ambient temperature range of the transmitter and sensor.

### Relative humidity

The device is suitable for use in outdoor and indoor areas with a relative humidity of 5 to 95%.

### Operating height

According to EN 61010-1

- Without overvoltage protection: ≤ 2 000 m
- With overvoltage protection: > 2 000 m (e.g. Endress+Hauser HAW series)

### Degree of protection

<b>Transmitter</b>	<ul style="list-style-type: none"> <li>▪ IP66/67, Type 4X enclosure, suitable for pollution degree 4</li> <li>▪ Open housing: IP20, Type 1 enclosure, suitable for pollution degree 2</li> </ul>
<b>Sensor</b>	IP66/67, Type 4X enclosure, suitable for pollution degree 4

### Vibration-resistance and shock-resistance

#### Compact version

<b>Vibration, sinusoidal</b> Following IEC 60068-2-6	2 to 8.4 Hz	3.5 mm peak
	8.4 to 2 000 Hz	1 g peak
<b>Vibration, broad-band random</b> Following IEC 60068-2-64	10 to 200 Hz	0.003 g <sup>2</sup> /Hz
	200 to 2 000 Hz	0.001 g <sup>2</sup> /Hz (1.54 g rms)
<b>Shocks, half-sine</b> Following IEC 60068-2-27	6 ms 30 g	

#### Shock

Due to rough handling similar to IEC 60068-2-31.

**Remote version (sensor)**

<b>Vibration, sinusoidal</b> Following IEC 60068-2-6	2 to 8.4 Hz	7.5 mm peak
	8.4 to 2 000 Hz	1 g peak
<b>Vibration, broad-band random</b> Following IEC 60068-2-6	10 to 200 Hz	0.01 g <sup>2</sup> /Hz
	200 to 2 000 Hz	0.003 g <sup>2</sup> /Hz (2.7 g rms)
<b>Shocks, half-sine</b> Following IEC 60068-2-6	6 ms 50 g	

**Shock**

Due to rough handling similar to IEC 60068-2-31.

**Electromagnetic compatibility (EMC)**

As per IEC/EN 61326 and  
NAMUR Recommendation NE 21



For more information: Declaration of Conformity

## Process

### Medium temperature range

0 to +60 °C (+32 to +140 °F)

### Conductivity

The minimum conductivity is:

- 5  $\mu\text{S}/\text{cm}$  for liquids in general
- 20  $\mu\text{S}/\text{cm}$  for demineralized water

The following basic conditions must be observed for  $< 20 \mu\text{S}/\text{cm}$ :

- Order code 013 for "Functionality", option D "Extended transmitter" and higher output signal damping is recommended for values under  $20 \mu\text{S}/\text{cm}$ .
- Observe the maximum permitted cable length  $L_{\text{max}}$ . This length is determined by the conductivity of the medium.
- With order code 013 "Functionality", option A "Standard transmitter" and empty pipe detection (EPD) switched on, the minimum conductivity is  $20 \mu\text{S}/\text{cm}$ .
- With order code 013 "Functionality", option A "Standard transmitter" - remote version, empty pipe detection may not be activated if  $L_{\text{max}} > 20 \text{ m}$ .

**i** Note that in the case of the remote version, the minimum conductivity depends on the cable length.

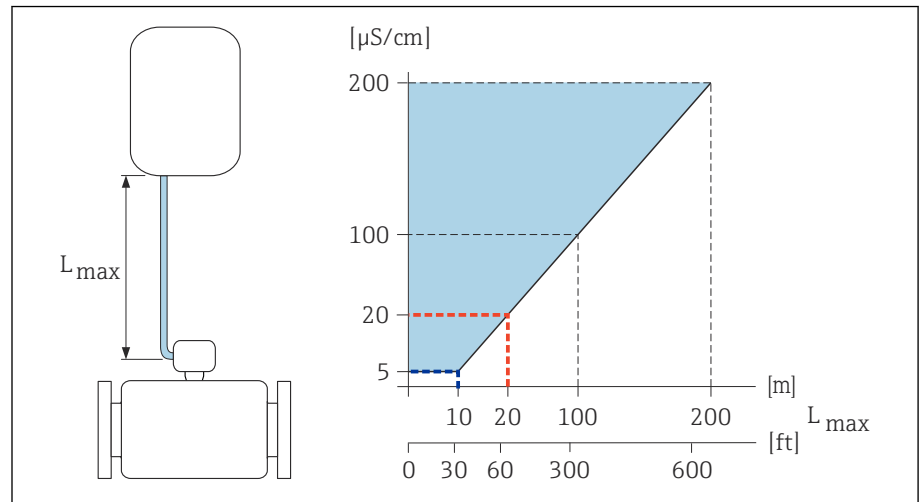

**10** Permitted length of connecting cable

Colored area = permitted range

$L_{\text{max}}$  = length of connecting cable in [m] ([ft])

[ $\mu\text{S}/\text{cm}$ ] = medium conductivity

Red line = order code 013 "Functionality", option A "Standard transmitter"

Blue line = order code 013 "Functionality", option D "Extended transmitter"

### Flow limit

Pipe diameter and flow rate determine the nominal diameter of the sensor.

**i** The flow velocity is increased by reducing the sensor nominal diameter.



2 to 3 m/s (6.56 to 9.84 ft/s)	Optimum flow velocity
$v < 2$ m/s (6.56 ft/s)	For abrasive media, e.g. potter's clay, lime milk, ore slurry
$v > 2$ m/s (6.56 ft/s)	For media producing buildup, e.g. wastewater sludge

### Pressure-temperature ratings

Permitted process pressure

Fixed flange similar to EN 1092-1  
 Fixed flange similar to ASME B16.5  
 Fixed flange similar to JIS B2220

Stainless steel

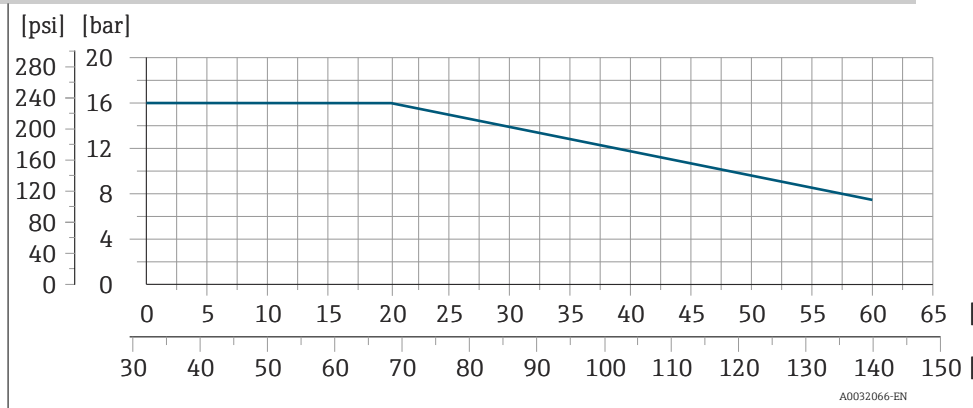

### Pressure tightness

Measuring tube: 0 mbar abs. (0 psi abs.) at a medium temperature of  $\leq +60$  °C (+140 °F)

### Pressure loss

- No pressure loss: transmitter installed in a pipe with the same nominal diameter.
- Pressure loss information when adapters are used → *Adapters*, 30

## Mechanical construction

### Weight

All values refer to devices with flanges with a standard pressure rating. Weight data are guideline values. The weight may be lower than indicated depending on the pressure rating and design.

#### Transmitter remote version

- Polycarbonate: 1.4 kg (3.1 lbs)
- Aluminum: 2.4 kg (5.3 lbs)

#### Sensor remote version

Aluminum sensor connection housing: see the information in the following table.

### Compact version

#### Weight in SI units

DN		Weight
[mm]	[in]	[kg]
25	1	3.20
40	1½	3.80
50	2	4.60
65	–	5.40
80	3	6.40
100	4	9.10

#### Weight in US units

DN		Weight
[mm]	[in]	[lbs]
25	1	7
40	1½	8
50	2	10
65	–	12
80	3	14
100	4	20

### Remote version

#### Weight in SI units

DN		Weight
[mm]	[in]	[kg]
25	1	2.5
40	1½	3.1
50	2	3.9
65	–	4.7

DN		Weight
[mm]	[in]	[kg]
80	3	5.7
100	4	8.4

### Weight in US units

DN		Weight
[mm]	[in]	[kg]
25	1	6
40	1½	7
50	2	9
65	–	10
80	3	13
100	4	19

## Measuring tube specification

### Wafer version

#### Pressure rating EN (DIN), PN16

DN		Mounting bolts			Centering sleeves		Measuring tube	
[mm]	[in]		[mm]	[in]	Length		Internal diameter	
					[mm]	[in]	[mm]	[in]
25	1	4 × M12 ×	145	5.71	54	2.13	24	0.94
40	1½	4 × M16 ×	170	6.69	68	2.68	38	1.50
50	2	4 × M16 ×	185	7.28	82	3.23	50	1.97
65 <sup>1)</sup>	–	4 × M16 ×	200	7.87	92	3.62	60	2.36
65 <sup>2)</sup>	–	8 × M16 ×	200	7.87	– <sup>3)</sup>	–	60	2.36
80	3	8 × M16 ×	225	8.86	116	4.57	76	2.99
100	4	8 × M16 ×	260	10.24	147	5.79	97	3.82

1) EN (DIN) flange: 4-hole → with centering sleeves

2) EN (DIN) flange: 8-hole → without centering sleeves

3) A centering sleeve is not required. The device is centered directly via the sensor housing.

#### Pressure rating ASME, Class 150

DN		Mounting bolts			Centering sleeves		Measuring tube	
[mm]	[in]		[mm]	[in]	Length		Internal diameter	
					[mm]	[in]	[mm]	[in]
25	1	4 × UNC ½" ×	145	5.70	– <sup>1)</sup>	–	24	0.94
40	1½	4 × UNC ½" ×	165	6.50	–	–	38	1.50
50	2	4 × UNC 5/8" ×	190.5	7.50	–	–	50	1.97

DN		Mounting bolts			Centering sleeves		Measuring tube	
[mm]	[in]		[mm]	[in]	Length		Internal diameter	
					[mm]	[in]	[mm]	[in]
80	3	8 × UNC 5/8" ×	235	9.25	–	–	76	2.99
100	4	8 × UNC 5/8" ×	264	10.4	147	5.79	97	3.82

1) A centering sleeve is not required. The device is centered directly via the sensor housing.

*Pressure rating JIS, 10K*

DN		Mounting bolts			Centering sleeves		Measuring tube	
[mm]	[in]		[mm]	[in]	Length		Internal diameter	
					[mm]	[in]	[mm]	[in]
25	1	4 × M16 ×	170	6.69	54	2.13	24	0.94
40	1 ½	4 × M16 ×	170	6.69	68	2.68	38	1.50
50	2	4 × M16 ×	185	7.28	– <sup>1)</sup>	–	50	1.97
65	–	4 × M16 ×	200	7.87	–	–	60	2.36
80	3	8 × M16 ×	225	8.86	–	–	76	2.99
100	4	8 × M16 ×	260	10.24	–	–	97	3.82

1) A centering sleeve is not required. The device is centered directly via the sensor housing.

**Threaded connection**

*Pressure rating EN (DIN), PN16*

DN		Threaded connection	Wrench size		Measuring tube	
[mm]	[in]		Length		Internal diameter	
			[mm]	[in]	[mm]	[in]
25	1	G 1"	28	1.1	24	0.94
40	1 ½	G 1 ½"	50	1.97	38	1.50
50	2	G 2"	60	2.36	50	1.97

*Pressure rating ASME, Class 150*

DN		Threaded connection	Wrench size		Measuring tube	
[mm]	[in]		Length		Internal diameter	
			[mm]	[in]	[mm]	[in]
25	1	NPT 1"	28	1.1	24	0.94
40	1 ½	NPT 1 ½"	50	1.97	38	1.50
50	2	NPT 2"	60	2.36	50	1.97

## Materials

### Transmitter housing

Order code for "Housing"	<ul style="list-style-type: none"> <li>■ Option A: compact, coated aluminum</li> <li>■ Option N: remote, polycarbonate</li> <li>■ Option P: remote, coated aluminum</li> </ul>
Window material	<ul style="list-style-type: none"> <li>■ Order code for "Housing", option A: glass</li> <li>■ Order code for "Housing", option N: polycarbonate</li> <li>■ Order code for "Housing", option P: glass</li> </ul>
Neck adapter	Order code for "Housing", option A: coated aluminum

### Sensor connection housing

Order code for "Sensor connection housing"	Option A: aluminum, AlSi10Mg, coated
--	--------------------------------------

### Cable glands and entries

Cable gland M20×1.5	Plastic
Adapter for cable entry with internal thread G ½" or NPT ½"	Nickel-plated brass

### Connecting cable for remote version

Electrode and coil current cable:  
PVC cable with copper shield

### Sensor housing

Aluminum, AlSi10Mg, coated

### Measuring pipe

Polyamide

### Liner

Polyamide

### Electrodes

Stainless steel: 1.4435 (316L)

### Seals

As per DIN EN 1514-1, Form IBC

### Process connections

EN 1092-1 (DIN 2501)	1.4301/304
ASME B16.5	1.4301/304
JIS B2220	1.4301/304
DIN ISO 228, G" external thread	1.4301/304
ASME B1.20, NPT" external thread	1.4301/304

**Accessories**

Protective cover	Stainless steel, 1.4404 (316L)
Pipe mounting set	Stainless steel 1.4301 (304)
Wall mounting kit	Stainless steel 1.4301 (304)

**Mounting bolts****Tensile strength**

- Galvanized steel mounting bolts: strength category 5.6 or 5.8
- Stainless steel mounting bolts: strength category A2-70

**Fitted electrodes**

Standard electrodes:  
Measuring electrodes

**Process connections**

- EN 1092-1 (DIN 2501)
- ASME B16.5
- JIS B2220
- DIN ISO 228, G external thread
- ASME B1.20, NPT external thread

## Local display

### Operation concept

Operation method	Operation via local display with touch screen <sup>1)</sup>
Reliable operation	<ul style="list-style-type: none"> <li>Operation in local language</li> <li>Standardized operating concept on the device and in the SmartBlue app</li> <li>Write protection</li> <li>When electronics modules are replaced: configurations are transferred using the T-DAT Backup device memory. The device memory contains process data, device data and the event logbook. No reconfiguration is necessary.</li> </ul>
Diagnostic behavior	<p>Efficient diagnostic behavior increases measurement availability:</p> <ul style="list-style-type: none"> <li>Open troubleshooting measures via local display and SmartBlue app.</li> <li>Diverse simulation options</li> <li>Logbook of events that have occurred.</li> </ul>

1) Only for communication protocols HART and Modbus RS485

### Operation options

Local display

A0042957

**11** Only for HART and Modbus RS485 communication protocols

Display elements:

- LCD touch screen <sup>1)</sup>
- Depends on the orientation, automatic alignment of the local display
- Configuration of display format for measured variables and status variables

Operating elements:

- Touch screen <sup>1)</sup>
- Local display can also be accessed in the hazardous area.

SmartBlue app

- The SmartBlue app allows the user to put devices into operation and operate them.
- Based on Bluetooth
- No separate driver required
- Available for mobile handheld terminals, tablets and smartphones
- Suitable for convenient and secure access to devices in hard-to-reach locations or in hazardous areas
- Can be used within a 20 m (65.6 ft) radius of the device
- Encrypted and secure data transmission
- No data loss during commissioning and maintenance
- Diagnostic information and process information in real time

1) Only for HART and Modbus RS485 communication protocols

## Operating tools

Operating tools	Operating unit	Interface	Additional information
DeviceCare SFE100	<ul style="list-style-type: none"> <li>▪ Notebook</li> <li>▪ PC</li> <li>▪ Tablet with Microsoft Windows system</li> </ul>	<ul style="list-style-type: none"> <li>▪ CDI service interface</li> <li>▪ Fieldbus protocol</li> </ul>	Innovation brochure IN01047S
FieldCare SFE500	<ul style="list-style-type: none"> <li>▪ Notebook</li> <li>▪ PC</li> <li>▪ Tablet with Microsoft Windows system</li> </ul>	<ul style="list-style-type: none"> <li>▪ CDI service interface</li> <li>▪ Fieldbus protocol</li> </ul>	Operating Instructions BA00027S and BA00059S
SmartBlue app	<ul style="list-style-type: none"> <li>▪ Devices with iOS: iOS9.0 or higher</li> <li>▪ Devices with Android: Android 4.4 KitKat or higher</li> </ul>	Bluetooth	Endress+HauserSmartBlue App: <ul style="list-style-type: none"> <li>▪ Google Playstore (Android)</li> <li>▪ iTunes Apple Shop (iOS devices)</li> </ul>

## Certificates and approvals

### Non-Ex approval

- cCSAus
- EAC
- UKCA

### Pressure Equipment Directive

- CRN
- PED Cat. II/III
- PESR Cat. II/III

### Drinking water approval

- ACS
- KTW/W270
- NSF 61
- WRAS BS 6920

### Radio approval

The device has radio approvals.

### External standards and guidelines

- IEC/EN 60529  
Degrees of protection provided by enclosure (IP code)
- IEC/EN 60068-2-6  
Environmental influences: Test procedure - Test Fc: vibrate (sinusoidal)
- IEC/EN 60068-2-31  
Environmental influences: Test procedure - Test Ec: shocks due to rough handling, primarily for devices.
- IEC/EN 61010-1  
Safety requirements for electrical equipment for measurement, control and laboratory use - general requirements.
- CAN/CSA-C22.2 No. 61010-1-12  
Safety Requirements for Electrical Equipment for Measurement, Control and Laboratory Use - Part 1 General Requirements.



- IEC/EN 61326  
Emission in accordance with Class A requirements. Electromagnetic compatibility (EMC requirements)
- ANSI/ISA-61010-1 (82.02.01)  
Safety Requirements for Electrical Equipment for Measurement, Control and Laboratory Use - Part 1 General Requirements.
- NAMUR NE 21  
Electromagnetic compatibility (EMC) of industrial process and laboratory control equipment.
- NAMUR NE 32  
Data retention in the event of a power failure in field devices and control instruments with microprocessors.
- NAMUR NE 43  
Standardization of the signal level for the breakdown information of digital transmitters with analog output signal.
- NAMUR NE 53  
Software of field devices and signal-processing devices with digital electronics.
- NAMUR NE 105  
Specifications for integrating fieldbus devices in engineering tools for field devices.
- NAMUR NE 107  
Self-monitoring and diagnosis of field devices.
- NAMUR NE 131  
Requirements for field devices for standard applications.
- ETSI EN 300 328  
Guidelines for 2.4 GHz radio components
- EN 301489  
Electromagnetic compatibility and radio spectrum matters (ERM).

## Application packages

### Use

Many different application packages are available to enhance the functionality of the device. Such packages might be needed to address safety aspects or specific application requirements.

The application packages can be ordered with the device or subsequently from Endress+Hauser. Detailed information on the relevant order code is available from your local Endress+Hauser sales organization or on the product page of the Endress+Hauser website: [www.endress.com](http://www.endress.com).

## Heartbeat Verification + Monitoring

### Heartbeat Verification

Availability depends on the product structure.

Meets the requirement for traceable verification according to DIN ISO 9001:2008 Clause 7.6 a) "Control of monitoring and measuring equipment":

- Functional testing in the installed state without interrupting the process.
- Traceable verification results on request, including report.
- Simple testing process with local operation or other operating interfaces
- Clear measuring point assessment (pass/fail) with high total test coverage within the framework of manufacturer specifications.
- Extension of calibration intervals according to operator's risk evaluation

### Heartbeat Monitoring

Availability depends on the product structure.

Heartbeat Monitoring continuously provides data characteristic of the measuring principle to an external condition monitoring system, facilitating preventive maintenance or process analysis. These data enable the operator to:

- Draw conclusions - using these data and other information - about the impact the process influences, e.g. corrosion, abrasion, formation of buildup, have on the measuring performance over time.
- Schedule servicing in time.
- Monitor the process quality or product quality, e.g. gas pockets.

## 14 Dimensions in SI units

---

<b>Compact version</b>	<b>116</b>
Wafer version	116
Threaded version	117
<b>Remote version</b>	<b>118</b>
Transmitter remote version	118
Sensor remote version	119
<b>Flange connections</b>	<b>121</b>
Flange similar to EN 1092-1: PN 16	121
Flange similar to ASME B16.5: Class 150	122
Flange JIS B2220: 10K	123
<b>Couplings</b>	<b>124</b>
External thread: ISO 228	124
External thread: ASME B1.20.1	124
<b>Accessories</b>	<b>125</b>
Protective cover	125

## Compact version

### Wafer version

Order code for "Housing", option A "Compact, aluminum, coated"

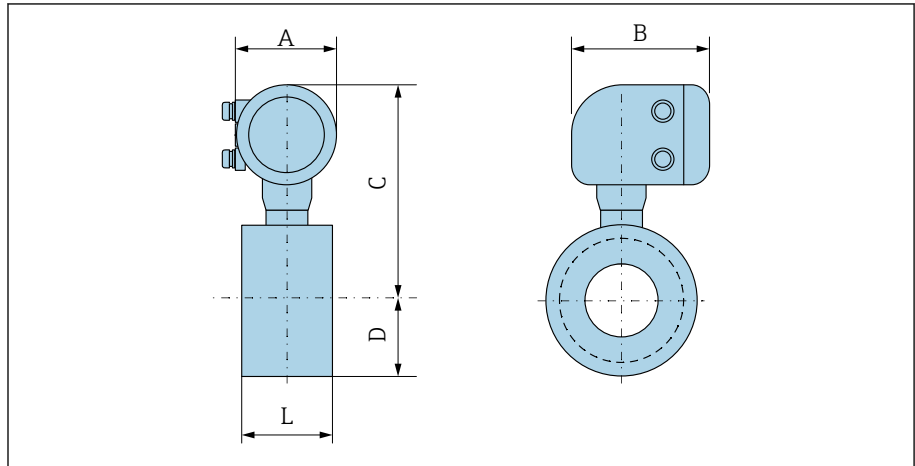

DN		A <sup>1)</sup>	B	C	D	L
[mm]	[in]	[mm]	[mm]	[mm]	[mm]	[mm]
25	1	139	178	259	43	55
40	1 ½	139	178	270	52	69
50	2	139	178	281	62	83
65	-	139	178	291	70	93
80	-	139	178	295	76	117
-	3	139	178	295	76	117
100	4	139	178	309	89	148

1) Depending on the cable entry used: values up to +30 mm

### Threaded version

Order code for "Housing", option A "Compact, aluminum, coated"

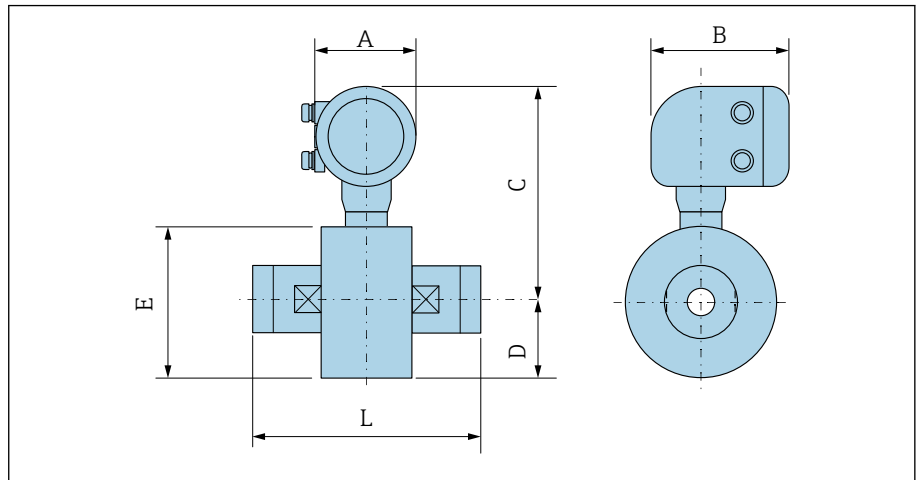

A0046007

DN		A <sup>1)</sup>	B	C	D	E	L
[mm]	[in]	[mm]	[mm]	[mm]	[mm]	[mm]	[mm]
25	1	139	178	259	43	86	110
40	1 ½	139	178	270	52	104	140
50	2	139	178	281	62	124	200

1) Depending on the cable entry used: values up to +30 mm

## Remote version

### Transmitter remote version

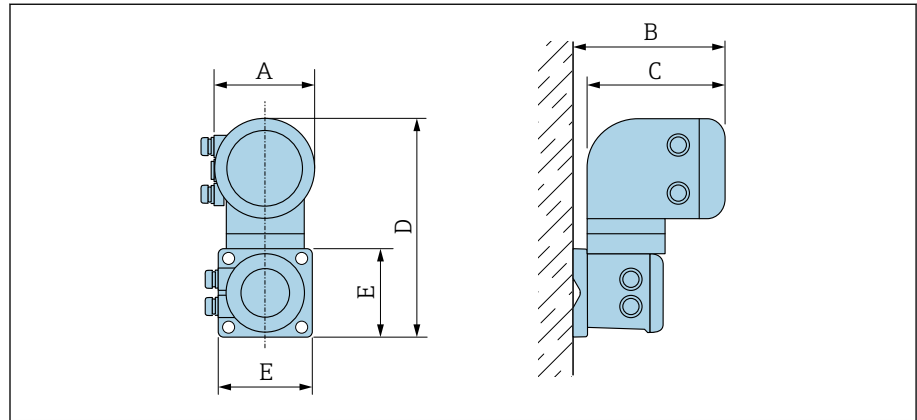

A0042715

Order code for "Housing"	A <sup>1)</sup> [mm]	B [mm]	C [mm]	D [mm]	E [mm]
Option N "Remote, polycarbonate"	132	187	172	307	130
Option P and T "Remote, coated aluminum"	139	185	178	309	130

1) Depending on the cable entry used: values up to + 30 mm

### Sensor remote version

#### Wafer version

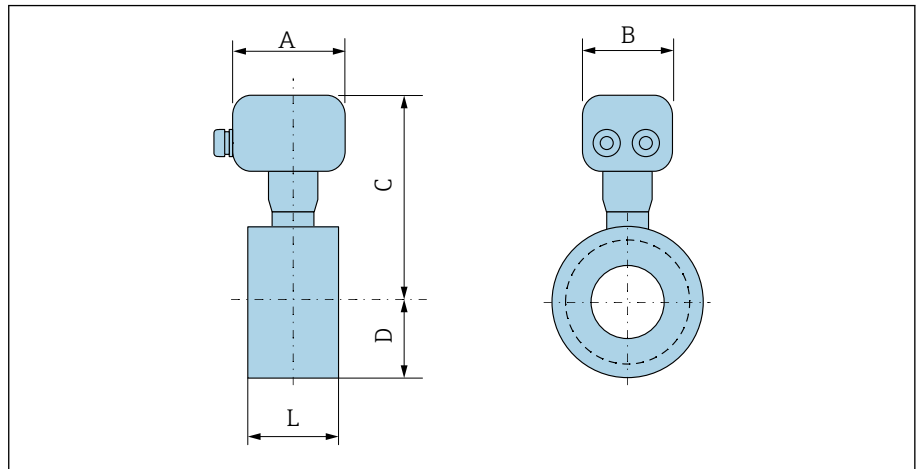

A0045564

DN		A <sup>1)</sup>	B	C	D	L
[mm]	[in]	[mm]	[mm]	[mm]	[mm]	[mm]
25	1	113	112	199	43	55
40	1 ½	113	112	210	52	69
50	2	113	112	221	62	83
65	-	113	112	231	70	93
80	-	113	112	235	76	117
-	3	113	112	235	76	117
100	4	113	112	249	89	148

1) Depending on the cable entry used: values up to +30 mm

## Threaded connection

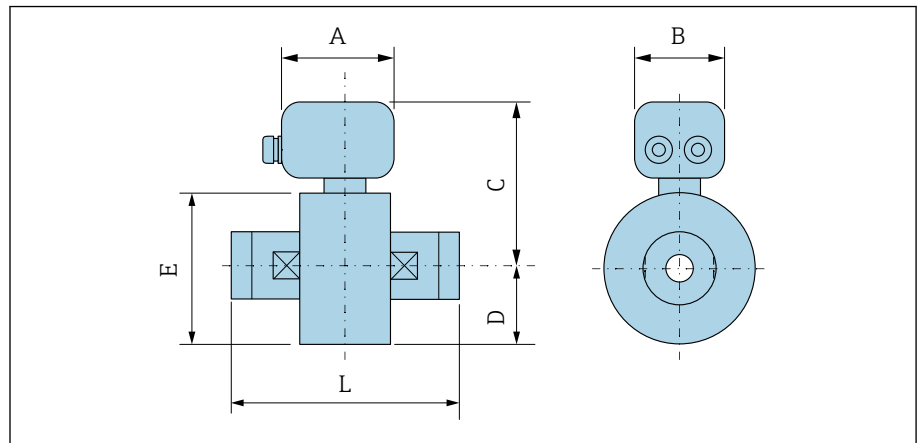

DN		A <sup>1)</sup>	B	C	D	E	L
[mm]	[in]	[mm]	[mm]	[mm]	[mm]	[mm]	[mm]
25	1	113	112	199	43	86	110
40	1 ½	113	112	210	52	104	140
50	2	113	112	221	62	124	200

1) Depending on the cable entry used: values up to +30 mm



## Flange connections

### Flange similar to EN 1092-1: PN 16

Order code for "Process connection", option D3Z

Dimension B: Internal diameter depends on the liner → *Measuring tube specification*,  107

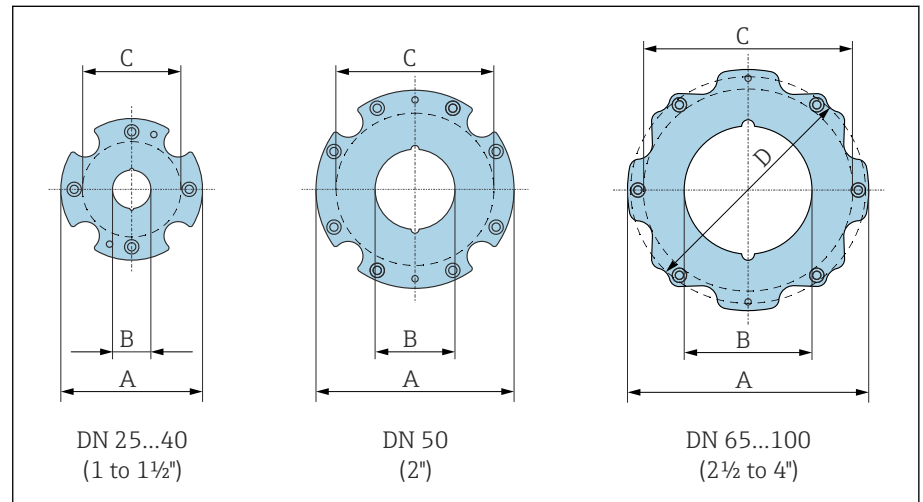

A0046000

DN [mm]	A [mm]	B [mm]	C <sup>1)</sup> [mm]
25	86	24	68
40	105	38	87
50	124	50	106
65	139	60	125
80	151	76	135
100	179	97	160

1) Max. Ø seals

### Flange similar to ASME B16.5: Class 150

Order code for "Process connection", option A1Z

Dimension B: internal diameter depends on the liner → *Measuring tube specification*, 107

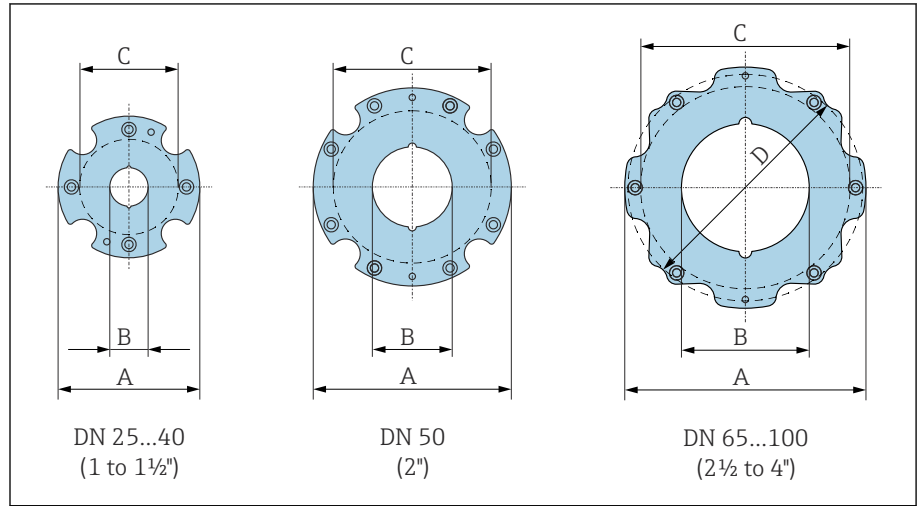

DN [in]	A [mm]	B [mm]	C <sup>1)</sup> [mm]	D [mm]
1	86	24	68	-
1 ½	105	38	87	-
2	124	50	106	-
3	151	76	135	138
4	179	97	160	-

1) Max. Ø seals

## Flange JIS B2220: 10K

Order code for "Process connection", option N3Z

Mass B: internal diameter depends on the liner → *Measuring tube specification*,  107

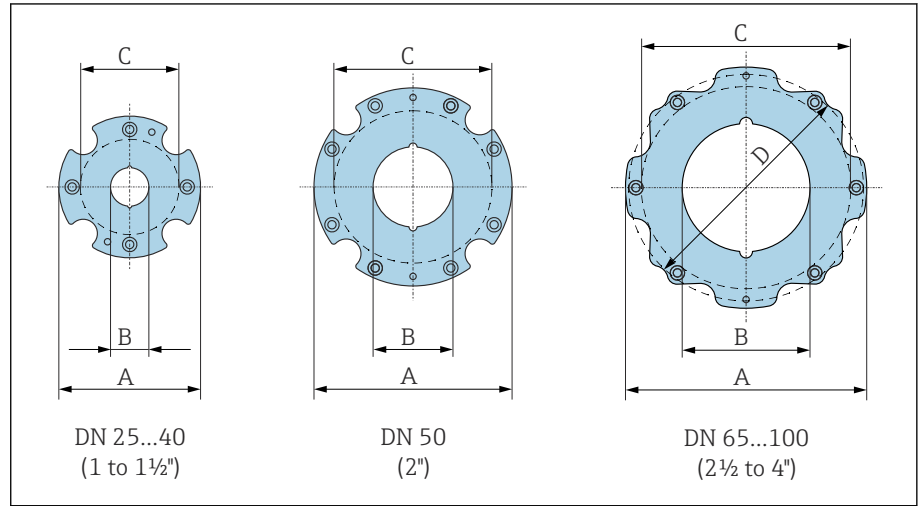

DN [mm]	A [mm]	B [mm]	C <sup>1)</sup> [mm]
25	86	24	68
40	105	38	87
50	124	50	106
65	139	60	125
80	151	76	135
100	179	97	160

1) Max. Ø seals

## Couplings

### External thread: ISO 228

Order code for "Process connection", option I4S

Mass B: internal diameter depends on the liner → *Measuring tube specification*, 107

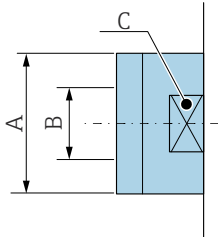

A0046008

DN [mm]	A [in]	B [mm]	C [mm]
25	G 1"	22	28
40	G 1 ½"	34.4	50
50	G 2"	43	60

### External thread: ASME B1.20.1

Order code for "Process connection", option I5S

Mass B: internal diameter depends on the liner → *Measuring tube specification*, 107

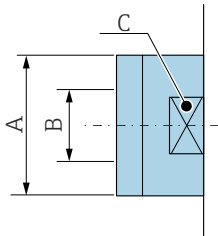

A0046008

DN [in]	A [in]	B [mm]	C [mm]
1	NPT 1"	22	28
1 ½	NPT 1 ½"	34.4	50
2	NPT 2"	43	60

## Accessories

### Protective cover

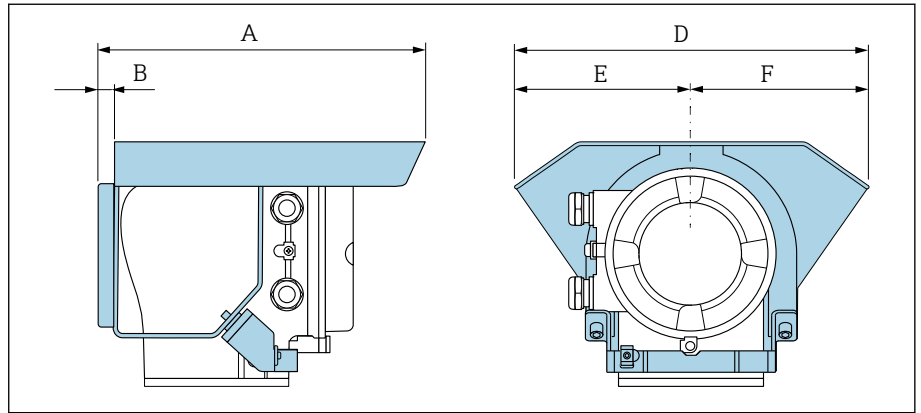

A0042332

A [mm]	B [mm]	D [mm]	E [mm]	F [mm]
257	12	280	140	140



## 15 Dimensions in US units

---

<b>Compact version</b>	<b>128</b>
Wafer version	128
Threaded version	129
<b>Remote version</b>	<b>130</b>
Transmitter remote version	130
Sensor remote version	131
<b>Flange connections</b>	<b>133</b>
Flange similar to ASME B16.5: Class 150	133
<b>Couplings</b>	<b>134</b>
External thread: ASME B1.20.1	134
<b>Accessories</b>	<b>135</b>
Protective cover	135

## Compact version

### Wafer version

Order code for "Housing", option A "Compact, aluminum, coated"

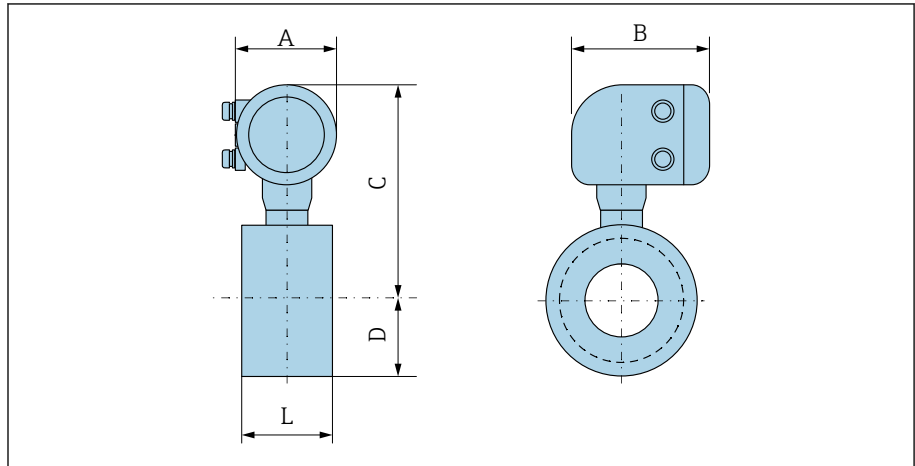

A0046005

DN [in]	A <sup>1)</sup> [in]	B [in]	C [in]	D [in]	L [in]
1	5.47	7.01	10.2	1.69	2.17
1 ½	5.47	7.01	10.63	2.05	2.72
2	5.47	7.01	11.06	2.44	3.27
3	5.47	7.01	11.61	2.99	4.61
4	5.47	7.01	12.17	3.5	5.83

1) Depending on the cable entry used: values up to +1.18 in



### Threaded version

Order code for "Housing", option A "Compact, aluminum, coated"

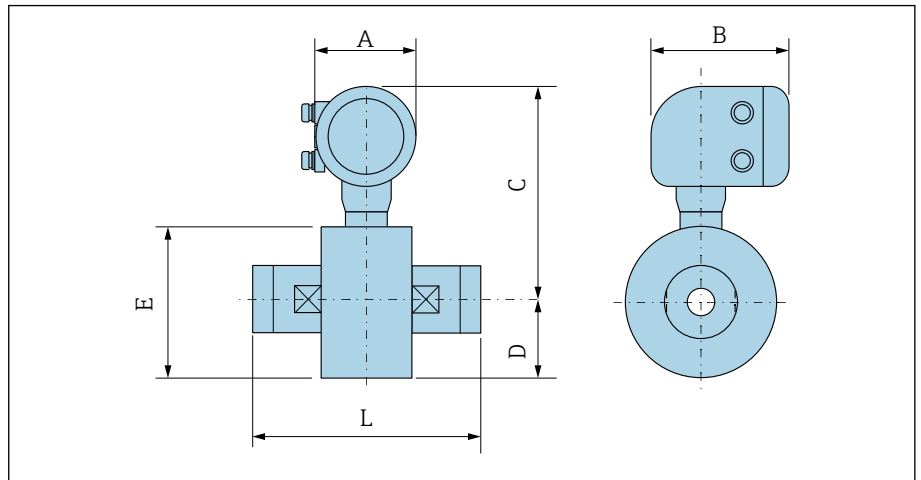

A0046007

DN [in]	A <sup>1)</sup> [in]	B [in]	C [in]	D [in]	E [in]	L [in]
1	5.47	7.01	10.2	1.69	3.39	4.33
1 ½	5.47	7.01	10.63	2.05	4.09	5.51
2	5.47	7.01	11.06	2.44	4.88	7.87

1) Depending on the cable entry used: values up to +1.18 in

## Remote version

### Transmitter remote version

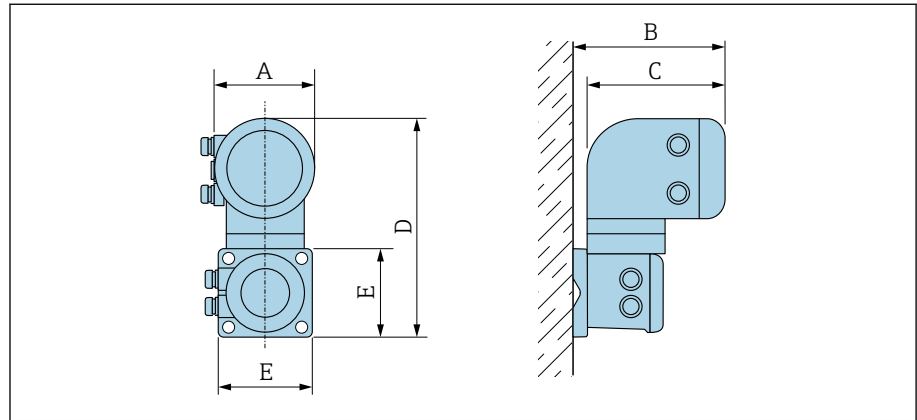

A0042715

Order code for "Housing"	A <sup>1)</sup> [in]	B [in]	C [in]	D [in]	E [in]
Option N "Remote, polycarbonate"	5.2	7.36	6.77	12.09	5.12
Option P and T "Remote, coated aluminum"	5.47	7.28	7.01	12.17	5.12

1) Depending on the cable entry used: values up to +1.18 in

## Sensor remote version

### Wafer version

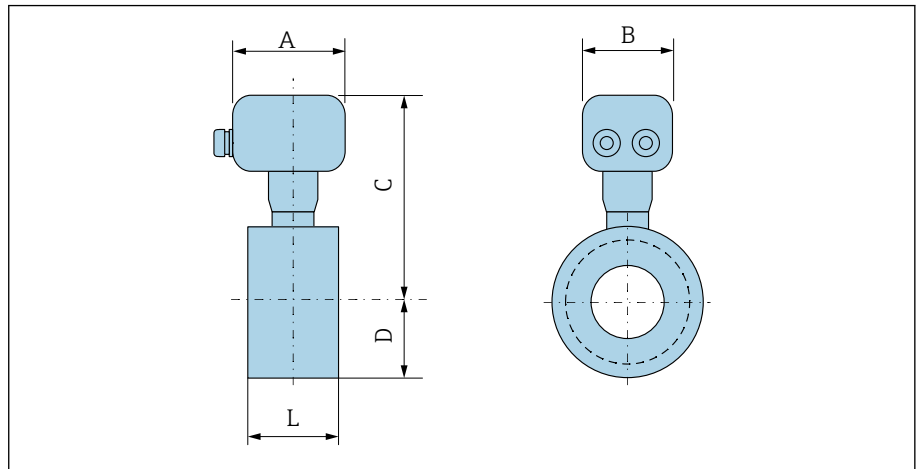

A0045564

DN [in]	A <sup>1)</sup> [in]	B [in]	C [in]	D [in]	L [in]
1	4.45	4.41	7.83	1.69	2.17
1 ½	4.45	4.41	8.27	2.05	2.72
2	4.45	4.41	8.7	2.44	3.27
3	4.45	4.41	9.25	2.99	4.61
4	4.45	4.41	9.8	3.5	5.83

1) Depending on the cable entry used: values up to +1.18 in

## Threaded connection

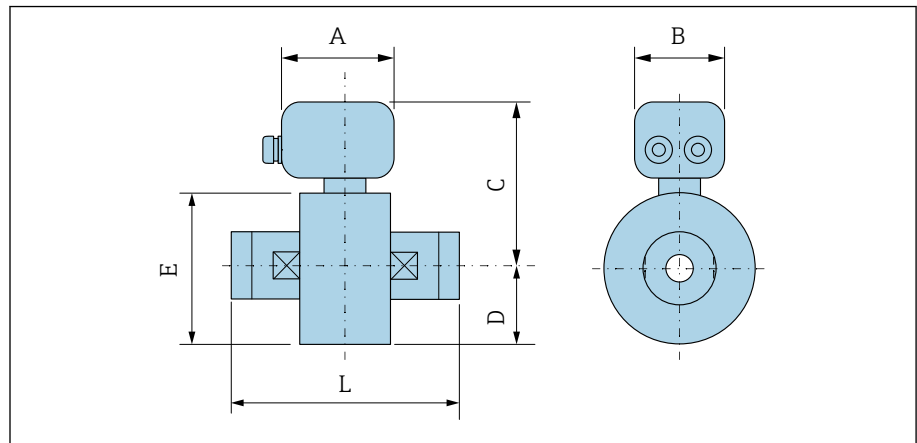

DN [in]	A <sup>1)</sup> [in]	B [in]	C [in]	D [in]	E [in]	L [in]
1	4.45	4.41	7.83	1.69	3.39	4.33
1 ½	4.45	4.41	8.27	2.05	4.09	5.51
2	4.45	4.41	8.7	2.44	4.88	7.87

1) Depending on the cable entry used: values up to +1.18 in

## Flange connections

### Flange similar to ASME B16.5: Class 150

Order code for "Process connection", option A1Z

Dimension B: Internal diameter depends on liner → *Measuring tube specification*,  107

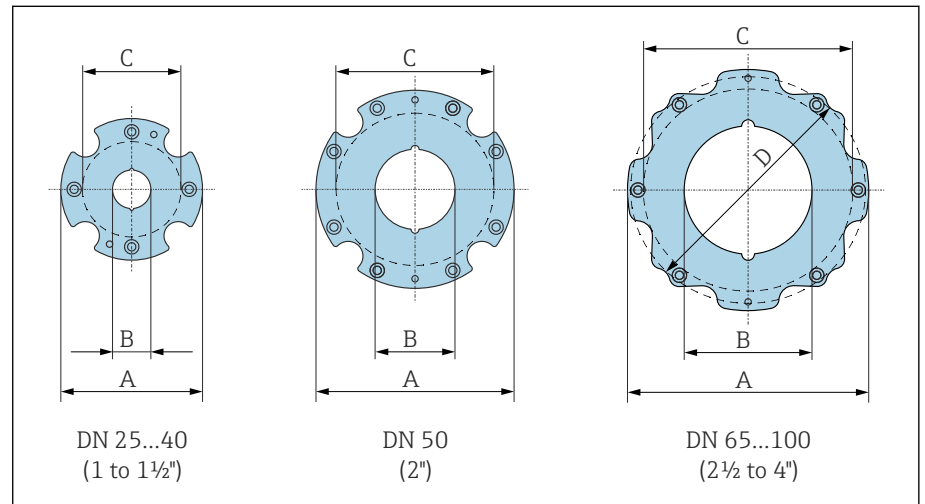

A0046000

DN [in]	A [in]	B [in]	C <sup>1)</sup> [in]	D [in]
1	3.39	0.94	2.68	-
1 ½	4.13	1.5	3.43	-
2	4.88	1.97	4.17	-
3	5.94	2.99	5.31	5.43
4	7.05	3.82	6.3	-

1) Max. Ø seals

## Couplings

### External thread: ASME B1.20.1

Order code for "Process connection", option I5S

Mass B: internal diameter depends on the liner → *Measuring tube specification*, 107

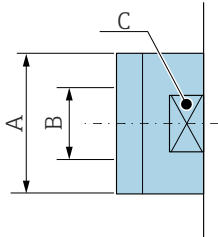

A0046008

DN [in]	A [in]	B [mm]	C [mm]
1	NPT 1"	22	28
1 ½	NPT 1 ½"	34.4	50
2	NPT 2"	43	60

### Accessories

#### Protective cover

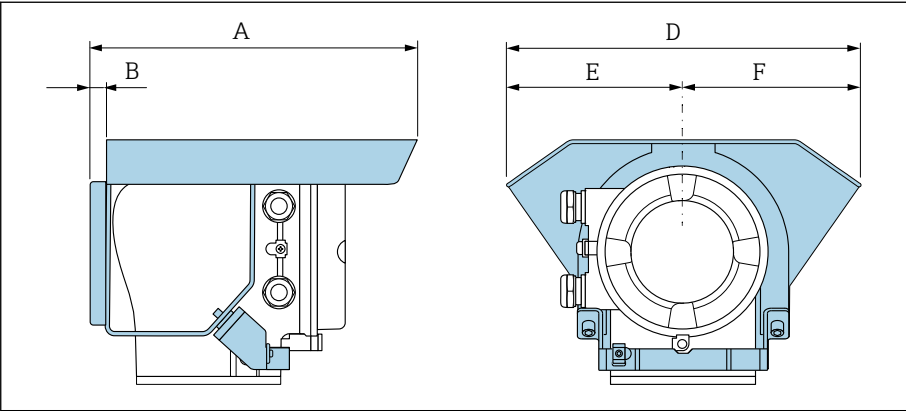

A0042332

A [in]	B [in]	D [in]	E [in]	F [in]
10.12	0.47	11.02	5.51	5.51







## 16 Accessories

---

Device-specific accessories	138
Communication-specific accessories	139
Service-specific accessory	139
System components	140

## Device-specific accessories













### Transmitter

Accessories	Description	Order code
Proline 10 transmitter	 Installation Instructions EA01350D	5XBBXX-*...*
Weather protection cover	Protects the device from weather exposure:  Installation Instructions EA01351D	71502730
Connecting cable	Can be ordered with the device. The following cable lengths are available: order code for "Cable, sensor connection" <ul style="list-style-type: none"> <li>▪ 5 m (16 ft)</li> <li>▪ 10 m (32 ft)</li> <li>▪ 20 m (65 ft)</li> <li>▪ User-configurable cable length, m (ft)</li> </ul>  Max. cable length: 200 m (660 ft)	DK5013-*...*



### Sensor

Accessories	Description
Mounting kit for wafer version	Consists of: <ul style="list-style-type: none"> <li>▪ Mounting bolts</li> <li>▪ Nuts with washers</li> <li>▪ Flange seals</li> <li>▪ Centering sleeves (if required for the flange)</li> </ul>
Seal set	Consists of: 2 flange seals



## Communication-specific accessories

Accessories	Description
Fieldgate FXA42	<p>Transmission of measured values from connected 4 to 20 mA analog and digital devices.</p> <ul style="list-style-type: none"> <li> Technical Information TI01297S</li> <li> Operating Instructions BA01778S</li> <li> Product page: <a href="http://www.endress.com/fxa42">www.endress.com/fxa42</a></li> </ul>
Field Xpert SMT50	<p>The Field Xpert SMT50 table PC for device configuration enables mobile plant asset management. It is suitable for commissioning and maintenance staff to manage field instruments with a digital communication interface and to record progress.</p> <p>This tablet PC is designed as an all-in-one solution with a preinstalled driver library and is an easy-to-use, touch-sensitive tool which can be used to manage field instruments throughout their entire life cycle.</p> <ul style="list-style-type: none"> <li> Technical Information TI01555S</li> <li> Operating Instructions BA02053S</li> <li> Product page: <a href="http://www.endress.com/smt50">www.endress.com/smt50</a></li> </ul>
Field Xpert SMT70	<p>Tablet PC for the configuration of the device. Enables mobile Plant Asset Management to manage the devices with a digital communication interface. Suitable for Zone 2.</p> <ul style="list-style-type: none"> <li> Technical Information TI01342S</li> <li> Operating Instructions BA01709S</li> <li> Product page: <a href="http://www.endress.com/smt70">www.endress.com/smt70</a></li> </ul>
Field Xpert SMT77	<p>Tablet PC for the configuration of the device. Enables mobile Plant Asset Management to manage the devices with a digital communication interface. Suitable for Zone 1.</p> <ul style="list-style-type: none"> <li> Technical Information TI01418S</li> <li> Operating Instructions BA01923S</li> <li> Product page: <a href="http://www.endress.com/smt77">www.endress.com/smt77</a></li> </ul>

## Service-specific accessory

Accessories	Description	Order code
Applicator	Software for selecting and sizing Endress+Hauser devices.	<a href="https://portal.endress.com/webapp/applicator">https://portal.endress.com/webapp/applicator</a>
Netilion	<p>IloT ecosystem: Unlock knowledge</p> <p>With the Netilion IloT ecosystem, Endress+Hauser allows you to optimize your plant performance, digitize workflows, share knowledge, and enhance collaboration.</p> <p>Drawing upon decades of experience in process automation, Endress+Hauser offers the process industry an IloT ecosystem designed to effortlessly extract insights from data. These insights can be used to optimize processes, leading to increased plant availability, efficiency, and reliability - ultimately driving higher profitability for your plant.</p>	<a href="http://www.netilion.endress.com">www.netilion.endress.com</a>
FieldCare	<p>FDT-based plant asset management software from Endress+Hauser. Management and configuration of Endress+Hauser devices.</p> <ul style="list-style-type: none"> <li> Operating Instructions BA00027S and BA00059S</li> </ul>	<ul style="list-style-type: none"> <li>▪ Device driver: <a href="http://www.endress.com">www.endress.com</a> → Download Area</li> <li>▪ CD-ROM (contact Endress+Hauser)</li> <li>▪ DVD (contact Endress+Hauser)</li> </ul>
DeviceCare	<p>Software for connecting and configuring Endress+Hauser devices.</p> <ul style="list-style-type: none"> <li> Innovation brochure IN01047S</li> </ul>	<ul style="list-style-type: none"> <li>▪ Device driver: <a href="http://www.endress.com">www.endress.com</a> → Download Area</li> <li>▪ CD-ROM (contact Endress+Hauser)</li> <li>▪ DVD (contact Endress+Hauser)</li> </ul>

## System components

Accessories	Description
Memograph M	Graphic data manager: <ul style="list-style-type: none"><li>▪ Record measured values</li><li>▪ Monitor limit values</li><li>▪ Analyze measuring points</li></ul>  <ul style="list-style-type: none"><li>▪ Technical Information TI00133R</li><li>▪ Operating Instructions BA00247R</li></ul>
iTEMP	Temperature transmitter: <ul style="list-style-type: none"><li>▪ Measure the absolute pressure and gauge pressure of gases, vapors and liquids</li><li>▪ Read the medium temperature</li></ul>  "Fields of Activity" document FA00006T

## 17 Appendix

---

Screw tightening torques	142
Examples of electric terminals	144

## Screw tightening torques

### General notes

Note the following for the screw tightening torques:

- Only for lubricated threads.
- Only for pipes that are free from tensile stress.
- Only if using an EPDM soft-material flat seal (e.g. 70° Shore A).
- Tighten the screws uniformly and in diagonally opposite sequence.
- Overtightening the screws will deform the sealing surface or damage the seal.

### Mounting bolts and centering sleeves for EN 1092 -1, PN 16

Nominal diameter [mm]	Mounting bolts [mm]	Length Centering sleeve [mm]	Max. screw tightening torque [Nm] for a process flange with ...	
			smooth seal face	Raised face
25	4 × M12 × 145	54	19	19
40	4 × M16 × 170	68	33	33
50	4 × M16 × 185	82	41	41
65 <sup>1)</sup>	4 × M16 × 200	92	44	44
65 <sup>2)</sup>	8 × M16 × 200	– <sup>3)</sup>	29	29
80	8 × M16 × 225	116	36	36
100	8 × M16 × 260	147	40	40

- 1) EN (DIN) flange: 4-hole → with centering sleeves  
 2) EN (DIN) flange: 8-hole → without centering sleeves  
 3) A centering sleeve is not required. The device is centered directly via the sensor housing.

### Mounting bolts and centering sleeves for ASME B16.5; Class 150

Nominal diameter		Mounting bolts [in]	Length Centering sleeve [in]	Max. screw tightening torque [Nm] ([lbf · ft]) for a process flange with ...	
[mm]	[in]			smooth seal face	Raised face
25	1	4 × UNC ½" × 5.70	– <sup>1)</sup>	19 (14)	10 (7)
40	1 ½	4 × UNC ½" × 6.50	– <sup>1)</sup>	29 (21)	19 (14)
50	2	4 × UNC 5/8" × 7.50	– <sup>1)</sup>	41 (30)	37 (27)
80	3	4 × UNC 5/8" × 9.25	– <sup>1)</sup>	43 (31)	43 (31)
100	4	8 × UNC 5/8" × 10.4	5.79	38 (28)	38 (28)

- 1) A centering sleeve is not required. The device is centered directly via the sensor housing.

### Mounting bolts and centering sleeves for JIS B2220, 10K

Nominal diameter [mm]	Mounting bolts [mm]	Length Centering sleeve [mm]	Max. screw tightening torque [Nm] for a process flange with ...	
			smooth seal face	Raised face
25	4 × M16 × 170	54	24	24
40	4 × M16 × 170	68	32	25
50	4 × M16 × 185	– <sup>1)</sup>	38	30
65	4 × M16 × 200	– <sup>1)</sup>	42	42
80	8 × M16 × 225	– <sup>1)</sup>	36	28
100	8 × M16 × 260	– <sup>1)</sup>	39	37

1) A centering sleeve is not required. The device is centered directly via the sensor housing.

## Examples of electric terminals

### Modbus RS485

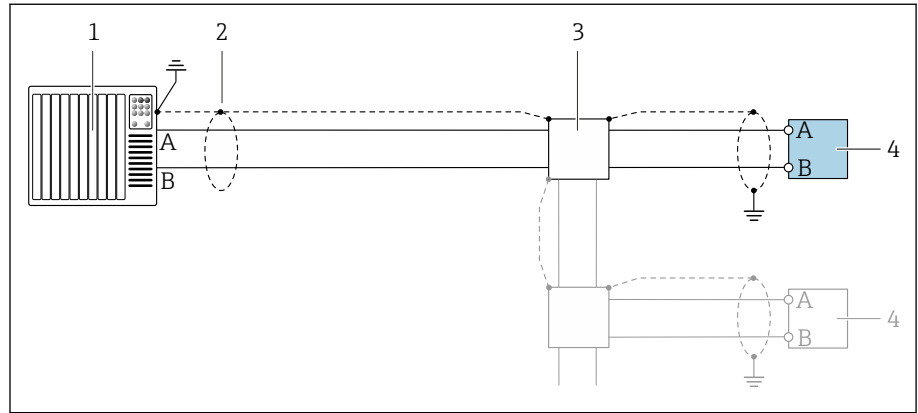

A0028765

12 Connection example for Modbus RS485, non-hazardous area and Zone 2; Class I, Division 2

- 1 Control system (e.g. PLC)
- 2 Cable shield
- 3 Distribution box
- 4 Transmitter

### Current output 4 to 20 mA (active)

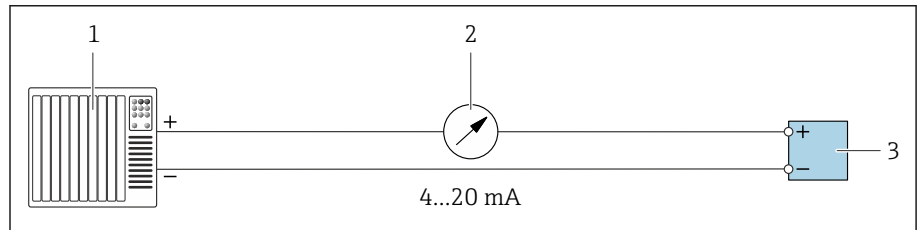

A0028758

- 1 Automation system with current input (e.g. PLC)
- 2 Analog display unit: observe max. load
- 3 Transmitter

### Current output 4 to 20 mA (passive)

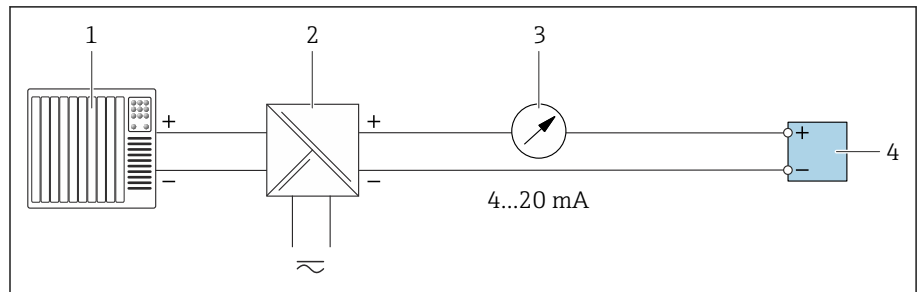

A0028759

- 1 Automation system with current input (e.g. PLC)
- 2 Active barrier for supply voltage (e.g. RN221N)
- 3 Analog display unit: observe max. load
- 4 Transmitter



## Index

### A

- Adapting the diagnostic behavior . . . . . 79
- Ambient conditions
  - Ambient temperature . . . . . 102
  - Vibration-resistance and shock-resistance . . . . . 102
- Ambient temperature
  - Influence . . . . . 101
- Ambient temperature range . . . . . 102
- Applicator . . . . . 92
- Approvals . . . . . 112
- Auto scan buffer
  - see Modbus RS485 Modbus data map

### C

- Certificates . . . . . 112
- Certificates and approvals . . . . . 112
- Check
  - Connection . . . . . 49
  - Installation . . . . . 36
- Checking the storage conditions (checklist) . . . . . 21
- Checklist
  - Post-connection check . . . . . 49
  - Post-installation check . . . . . 36
- Cleaning of surfaces not in contact with medium . . . . . 88
- Commissioning . . . . . 65, 66
  - see Commissioning wizard
  - see Via local operation
  - see Via SmartBlue App
- Switching on the device . . . . . 67
- Commissioning the device . . . . . 68
- Compatibility . . . . . 24
- Conductivity . . . . . 104
- Connecting the connecting cable
  - Sensor connection housing . . . . . 41
  - Transmitter connection housing . . . . . 41

### D

- Date of manufacture . . . . . 17, 18
- Degree of protection . . . . . 102
- Design
  - Device . . . . . 22
- Device
  - Design . . . . . 22
  - Disposal . . . . . 90
  - Removal . . . . . 90
- Device components . . . . . 22
- Device description files . . . . . 60
- Device history . . . . . 24
- Device locking, status . . . . . 72
- Device name
  - Sensor . . . . . 18
  - Transmitter . . . . . 17
- Diagnosis
  - Symbols . . . . . 77
- Diagnostic information
  - Design, description . . . . . 78

- DeviceCare . . . . . 78
- FieldCare . . . . . 78
- Light emitting diodes
  - LED . . . . . 75
- Local display . . . . . 77
- Overview . . . . . 79
- Remedial measures . . . . . 79
- Diagnostic information in FieldCare or DeviceCare . . . . . 78
- Diagnostic information via LED . . . . . 75
- Diagnostic list . . . . . 82
- Diagnostic message . . . . . 77
- Display
  - Current diagnostic event . . . . . 82
  - Previous diagnostic event . . . . . 82
- Display values
  - For locking status . . . . . 72
- Disposal . . . . . 89
- Disposing of the device . . . . . 90
- Drinking water approval . . . . . 112

### E

- Electromagnetic compatibility . . . . . 103
- Electronics module . . . . . 22
- Endress+Hauser services
  - Maintenance . . . . . 88
- Environment
  - Storage temperature . . . . . 102
- Error messages
  - see Diagnostic messages
- Event logbook . . . . . 83
- Events list . . . . . 83
- Extended order code
  - Sensor . . . . . 18
  - Transmitter . . . . . 17

### F

- Filtering the event logbook . . . . . 83
- Firmware history . . . . . 24
- Fitted electrodes . . . . . 110
- Flow limit . . . . . 104
- Function codes . . . . . 60

### G

- Galvanic isolation . . . . . 94
- General troubleshooting . . . . . 74

### I

- Identifying the device . . . . . 17
- Incoming acceptance (checklist) . . . . . 16
- Influence
  - Ambient temperature . . . . . 101
- Influence of ambient temperature . . . . . 101
- Input . . . . . 92
- Inspection
  - Received goods . . . . . 16
- Installation
  - Mounting kit . . . . . 31

Intended use . . . . .	16	Post-connection check . . . . .	66
<b>L</b>		Post-connection check (checklist) . . . . .	49
Local display		Post-installation check . . . . .	66
see Diagnostic message		Post-installation check (checklist) . . . . .	36
see In alarm condition		Post-installation check and post-connection check . . .	66
Local operation . . . . .	68	Potential equalization . . . . .	45
Low flow cut off . . . . .	94	Pressure Equipment Directive . . . . .	112
<b>M</b>		Pressure loss . . . . .	105
Magnetism . . . . .	30	Pressure tightness . . . . .	105
Magnetism and static electricity . . . . .	30	Pressure-temperature ratings . . . . .	105
Main electronics module . . . . .	22	Process conditions	
Maintenance work . . . . .	88	Conductivity . . . . .	104
Materials . . . . .	109	Flow limit . . . . .	104
Maximum measurement error . . . . .	100	Medium temperature . . . . .	104
Measured variable		Pressure loss . . . . .	105
see Process variables		Pressure tightness . . . . .	105
Measuring instrument		Pressure-temperature ratings . . . . .	105
Integrating via communication protocol . . . . .	59	Process connections . . . . .	110
Mounting the sensor		Product design . . . . .	22
Arranging the mounting bolts and centering		Product identification . . . . .	17
sleeves . . . . .	33	<b>R</b>	
Measuring principle . . . . .	16	Radio approval . . . . .	112
Measuring range . . . . .	92	Reading off the device locking status . . . . .	72
Measuring tube specification . . . . .	107	Reading out the event logbook . . . . .	83
Medium temperature range . . . . .	104	Recycling of packaging materials . . . . .	21
Modbus RS485		Reference operating conditions . . . . .	100
Function codes . . . . .	60	Registered trademarks . . . . .	9
Modbus data map . . . . .	62	Removing the device . . . . .	90
Read access . . . . .	60	Repeatability . . . . .	100
Reading out data . . . . .	63	Resetting the device	
Register addresses . . . . .	61	Settings . . . . .	84
Register information . . . . .	61	<b>S</b>	
Response time . . . . .	61	Safety instructions . . . . .	11
Scan list . . . . .	63	Sensor nameplate . . . . .	18
Write access . . . . .	60	Serial number . . . . .	17, 18
Mounting bolts . . . . .	110	Services . . . . .	88
Mounting kit . . . . .	31	Signal on alarm . . . . .	94
<b>N</b>		SmartBlue App . . . . .	68
Nameplate		Standards and guidelines . . . . .	112
Sensor . . . . .	18	Static electricity . . . . .	30
Transmitter . . . . .	17	Status signals . . . . .	77
Non-Ex approval . . . . .	112	Storage . . . . .	21
<b>O</b>		Storage conditions . . . . .	21
Operable flow range . . . . .	92	Storage temperature . . . . .	21, 102
Operation . . . . .	51, 71	Storage temperature range . . . . .	102
Order code . . . . .	17, 18	Submenu	
Output signal . . . . .	93	Device management . . . . .	72
Output variables . . . . .	93	Events list . . . . .	83
Overview of diagnostic information . . . . .	79	Switching on the device . . . . .	67
<b>P</b>		System design	
Packaging disposal . . . . .	21	see Device design	
Parameter settings		System integration . . . . .	59
Device management (Submenu) . . . . .	72	<b>T</b>	
Pending diagnostic events . . . . .	82	Temperature range	
Performance characteristics . . . . .	100	Storage temperature . . . . .	21

---

Tools	
Transport . . . . .	19
Transmitter nameplate . . . . .	17
Transport	
Transporting the device . . . . .	19
Troubleshooting	
General . . . . .	74
<b>U</b>	
Using the device	
see Intended use	
<b>V</b>	
Vibration-resistance and shock-resistance . . . . .	102
<b>W</b>	
W@M Device Viewer . . . . .	17
Weight	
Compact version . . . . .	106
Transport (notes) . . . . .	19
Wiring the sensor connection housing . . . . .	41
Wiring the transmitter housing . . . . .	41



[www.addresses.endress.com](http://www.addresses.endress.com)

---