

Installation Instructions

Filter mat

Replacement/retrofitting for sampler Liquistation
CSFxx



Table of contents

1	Overview of CSFxx	3
2	Intended use	3
3	Authorized installation personnel	4
4	Safety instructions	4
5	Scope of delivery	5
6	Additional documentation	8
7	Tool list	8
8	Replacement of spare parts	8
9	Disposal	16

1 Overview of CSFxx

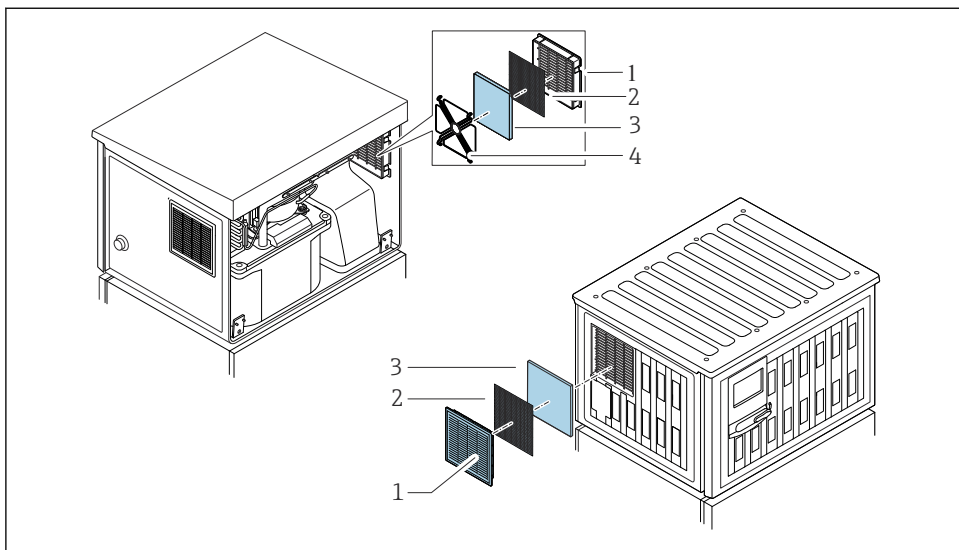

A0055151

- 1 *Liquistation CSFxx, with stainless steel housing (graphic on left, rear view) and with plastic housing (graphic on right, front view)*

- 1 *Ventilation grid*
- 2 *Metal braiding*
- 3 *Filter mat*
- 4 *Retaining bracket*

2 Intended use

- The components of the kit are to be used exclusively as retrofit or spare parts for CSFxx automatic samplers. Any other use is not permitted!
- Use only original parts from Endress+Hauser.
- In the W@M Device Viewer, check if the spare part is suitable for the existing device.

3 Authorized installation personnel

- Installation, commissioning, operation and maintenance of the measuring system may be carried out only by specially trained technical personnel.
- The technical personnel must be authorized by the plant operator to carry out the specified activities.
- The electrical connection may be performed only by an electrical technician.
- The technical personnel must have read and understood these Installation Instructions and must follow the instructions they contain.
- Faults at the measuring point may only be rectified by authorized and specially trained personnel.

 Repairs not described in the Operating Instructions provided must only be carried out directly at the manufacturer's site or by the service organization.

4 Safety instructions

CAUTION

Reduced cooling capacity of the cooling module due to reduced air flow rate (contaminated filter mat).

- ▶ Replace the filter mat after six months in service at the very least.
- ▶ Adapt the replacement interval to the ambient conditions (shorten if necessary).

WARNING

Danger! Mains voltage!

- ▶ Stop active sampling programs.
- ▶ Disconnect the sampler from the mains voltage.
- ▶ Ensure that the sampler is safely disconnected from the mains voltage when carrying out the replacement.

5 Scope of delivery

5.1 Accessory kit in the CSFxx device delivered

The kit contains the following parts →  2,  5:

1 x Filter mat G2 167x167x5mm

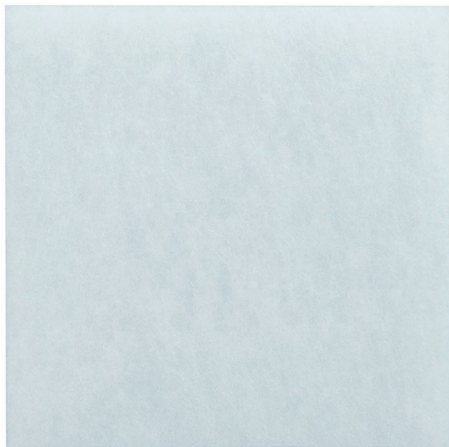

 2 *Accessory kit in the device delivered*

A0046378

5.2 71217058 kit filter set CSFxx

The kit contains the following parts →  3,  6:

10 x Filter mat G2 167x167x5mm

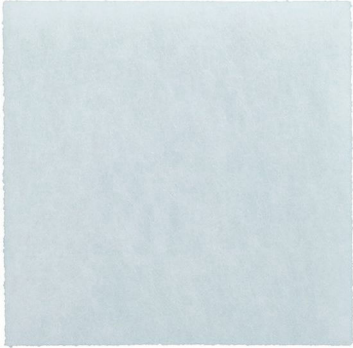

A0053342

 3 71217058 kit filter set CSFxx

5.3 71225577 kit CSF48 filter retrofitting stainless steel

The kit contains the following parts →  4,  7:

2 x Filter mat G2 167x167x5mm

1 x Retaining bracket

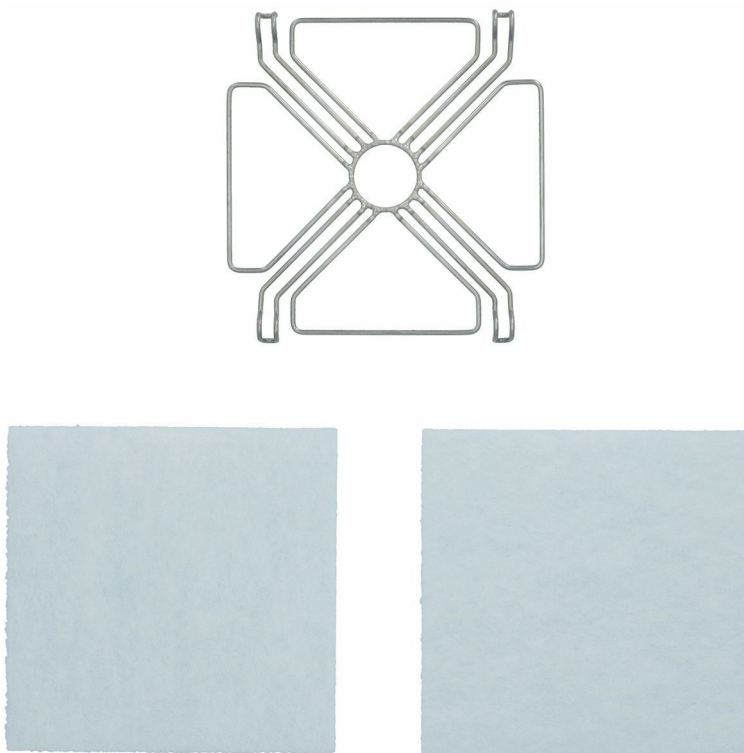

A0048381

 4 71225577 kit CSF48 filter retrofitting stainless steel

5.4 71623229 kit CSFxx metal grid

The kit contains the following parts →  4,  7:

- 2 x Metal braiding V4A 160x160mm
- 2 x Metal braiding V4A 166x166mm

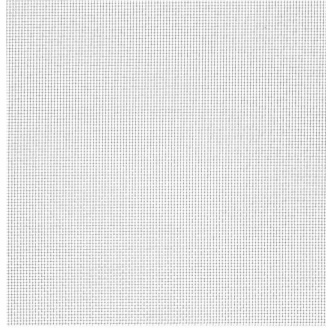
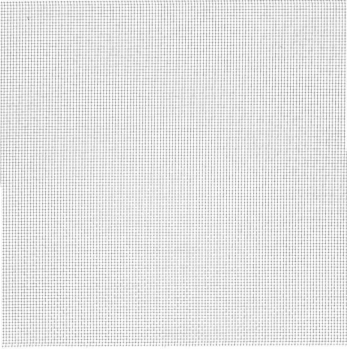

A0055084

- 5 71623229 CSFxx metal grid for stainless steel housing (image on left) and for plastic housing (image on right)

6 Additional documentation

Detailed information on the device can be found in the Operating Instructions for the sampler in question and in the other documentation available via:

- www.endress.com/device-viewer
- smartphone/tablet: Endress+Hauser Operations app

7 Tool list

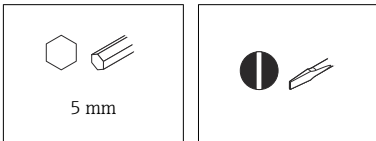

8 Replacement of spare parts

- ▶ Follow the installation instructions in the operating instructions for the sampler used.

8.1 Replacement in sampler with plastic housing

1. Stop the current sampling program.
2. Disconnect the sampler from the mains voltage and ensure it is secured to prevent accidental reactivation.

3. Using a small screwdriver, lever out the left ventilation grid (front view) and push it outwards.



A0048382

4. Take off the ventilation grid and remove the used filter mat if one is present.



A0048383

5. Take the new filter mat out of the kit supplied and place it in the ventilation grid.



A0048384

6. Check the metal braiding for damage and replace if necessary.
7. Click the ventilation grid with the filter mat from the outside back into the frame.

i Viewed from the outside, the angled slats of the ventilation grid must slope downwards.



A0048385

8. Reconnect the sampler to the mains voltage and start the sampling program.
9. Perform a function test with the sampler.

8.2 Replacement/installation in sampler with stainless steel housing

Removing the rear panel of the dosing compartment

1. Stop the current sampling program.
2. Disconnect the sampler from the mains voltage and ensure it is secured to prevent accidental reactivation.
3. Open the door of the dosing compartment.
4. Using an Allen key, loosen the screw above the dosing compartment to unfasten the rear panel of the dosing compartment.

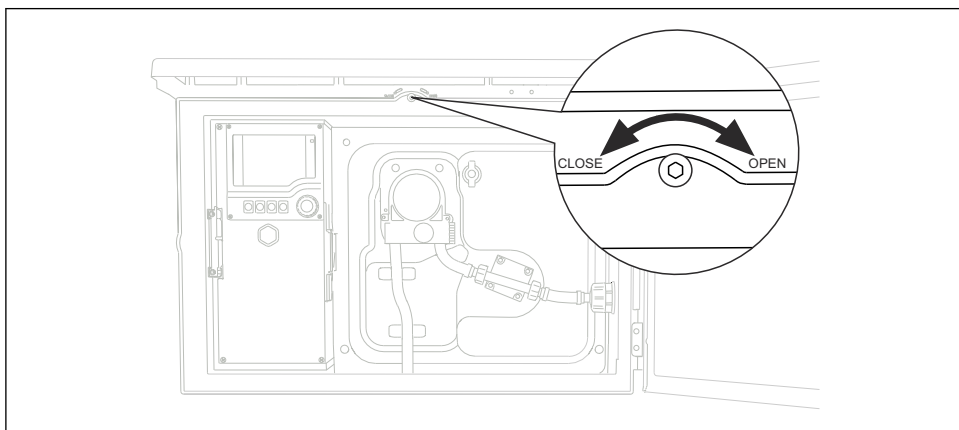

A0048978

5. Lift the rear panel upwards.

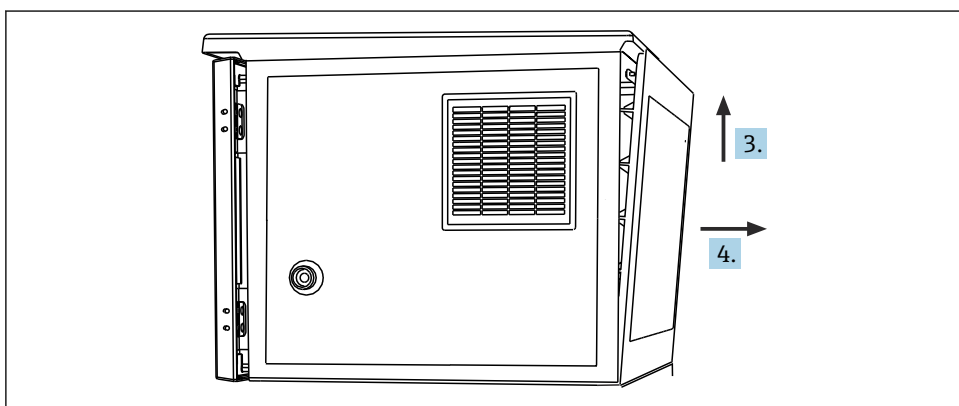

A0048979

6. Pull the rear panel backwards and store it in a safe place.

Replacing the filter mat

1. Remove the retaining bracket on the ventilation grid on the inside and put it in a safe place.



A0048393

2. Remove the used filter mat.



A0048394

3. Check the metal braiding for damage and replace if necessary.
4. Take the new filter mat out of the kit supplied and place it in the ventilation grid.

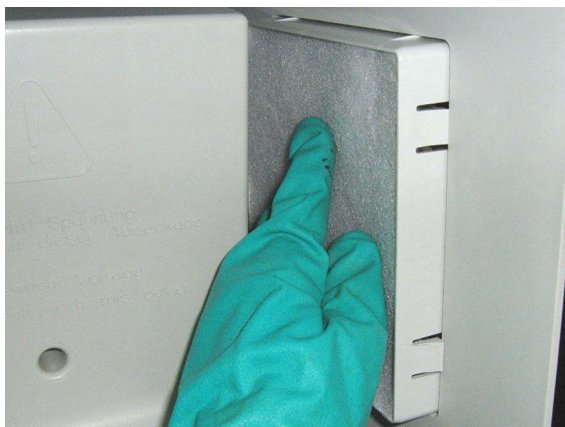

A0048395

5. Push the retaining bracket onto the pins (x 4) on the inside of the ventilation grid. The pins of the retaining bracket must lock into place!



A0048388

Retrofitting the filter mat

1. Take a filter mat out of the kit supplied and place it in the ventilation grid.



A0048395

2. Push the retaining bracket onto the pins (x 4) on the inside of the ventilation grid. The pins of the retaining bracket must lock into place!



A0048388

Installing the rear panel of the dosing compartment

1. Slide the rear panel into the bracket from below and then guide the metal tabs into the slots provided for this purpose.
2. Tighten the screw above the dosing compartment with an Allen key to secure the rear panel of the dosing compartment.

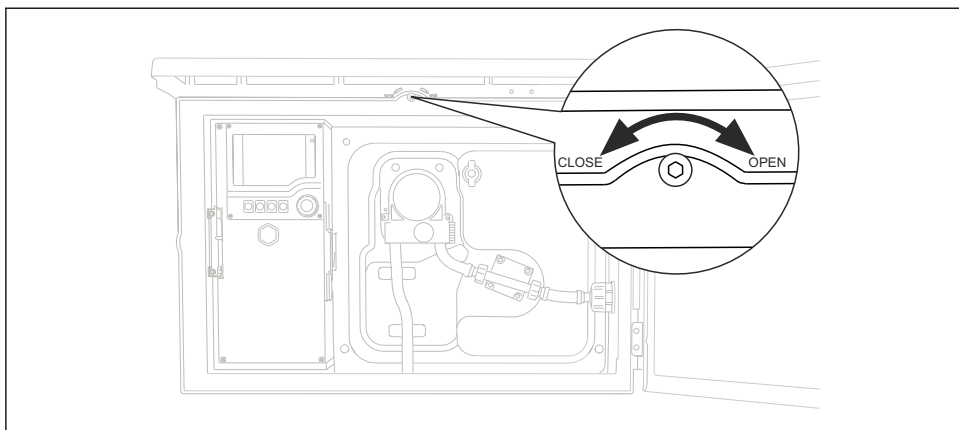

A0048978

3. Close the door of the dosing compartment.
4. Reconnect the sampler to the mains voltage and start the sampling program.
5. Perform a function test with the sampler.

9 Disposal

- ▶ Observe the local regulations.



71656633

www.addresses.endress.com
