

# Technical Information

## iTHERM TS212

### Insert for thermometer installation



#### Application

- Universal range of application
- Measuring range RTD: -200 to +600 °C (-328 to +1 112 °F)
- Measuring range TC: -40 to +1 100 °C (-40 to +2 012 °F)
- For installation in thermometers

#### Sensor types

Best in class sensor from Endress+Hauser for highest plant availability and safety:

- iTHERM StrongSens for a best-in-class vibration resistance
- iTHERM QuickSens for the shortest response times worldwide
- Single or double wire wound sensor
- Single or double thin film sensor

#### Your benefits

- Easy and fast recalibration due to iTHERM QuickNeck
- High degree of flexibility thanks to customized immersion lengths
- High degree of compatibility and design as per IEC 60751
- Extremely vibration-resistant
- Very fast response times
- Types of protection for use in hazardous locations:
  - Intrinsic Safety (IS)
  - Non-sparking (NI)
- 38.1 mm (½ in) spring travel for ease of installation

---

## Table of contents

<b>Function and system design</b> . . . . .	<b>3</b>
Measuring principle . . . . .	3
Equipment architecture . . . . .	3
<b>Input</b> . . . . .	<b>5</b>
Measured variable . . . . .	5
Measuring range . . . . .	5
Cable resistance . . . . .	5
<b>Output</b> . . . . .	<b>5</b>
Output signal . . . . .	5
Family of temperature transmitters . . . . .	6
<b>Power supply</b> . . . . .	<b>6</b>
Electrical connection . . . . .	6
<b>Performance characteristics</b> . . . . .	<b>8</b>
Maximum measured error . . . . .	8
Self-heating . . . . .	9
Response time . . . . .	9
Calibration . . . . .	11
Insulation resistance . . . . .	12
Dielectric strength . . . . .	13
<b>Installation</b> . . . . .	<b>13</b>
Orientation . . . . .	13
Installation instructions . . . . .	13
Immersion length . . . . .	13
<b>Environment</b> . . . . .	<b>14</b>
Ambient temperature range . . . . .	14
Vibration resistance . . . . .	14
Shock resistance . . . . .	15
<b>Mechanical construction</b> . . . . .	<b>15</b>
Design, dimensions . . . . .	15
Materials . . . . .	19
<b>Certificates and approvals</b> . . . . .	<b>19</b>
<b>Ordering information</b> . . . . .	<b>19</b>
<b>Accessories</b> . . . . .	<b>19</b>
Service-specific accessories . . . . .	20
<b>Documentation</b> . . . . .	<b>20</b>

---

## Function and system design

---

### Measuring principle

This insert is a universal temperature measuring element which can be used as a replaceable insert for industrial platinum resistance thermometers as per ASTM E 1137/E 1137 M-2008. With this insert, a Pt100 as per IEC 60751 or a thermocouple type K, J or N as per IEC 60584-2 or ASTM E230-11 can be used as the temperature sensor. The Pt100 is a temperature-sensitive platinum resistor with a resistance of 100  $\Omega$  at 0 °C (32 °F) and a temperature coefficient  $\alpha = 0.003851 \text{ }^\circ\text{C}^{-1}$ .

### Resistance thermometer (RTD)

**There are generally two different kinds of platinum resistance thermometers:**

- **Wire wound (WW):** Here, a double coil of fine, high-purity platinum wire is located in a ceramic support. This is then sealed top and bottom with a ceramic protective layer. Such resistance thermometers not only facilitate very reproducible measurements but also offer good long-term stability of the resistance/temperature characteristic within temperature ranges up to 600 °C (1 112 °F). This type of sensor is relatively large in size and it is comparatively sensitive to vibrations.
- **Thin film platinum resistance thermometers (Thin Film, TF):** A very thin, ultrapure platinum layer, approx. 1  $\mu\text{m}$  thick, is vaporized in a vacuum on a ceramic substrate and then structured photolithographically. The platinum conductor paths formed in this way create the measuring resistance. Additional covering and passivation layers are applied and reliably protect the thin platinum layer from contamination and oxidation, even at high temperatures.

The primary advantages of thin film temperature sensors over wire wound versions are their smaller sizes and better vibration resistance. A relatively low principle-based deviation of the resistance/temperature characteristic from the standard characteristic of IEC 60751 can frequently be observed among TF sensors at high temperatures. As a result, the tight limit values of tolerance category A as per IEC 60751 can only be observed with TF sensors at temperatures up to approx. 300 °C (572 °F).

### Thermocouples (TC)

Thermocouples are comparatively simple, robust temperature sensors which use the Seebeck effect for temperature measurement: If two electrical conductors made of different materials are connected at a point, a weak electrical voltage can be measured between the two open conductor ends if the conductors are subjected to a thermal gradient. This voltage is called thermoelectric voltage or electromotive force (emf). Its magnitude depends on the type of conducting materials and the temperature difference between the "measuring point" (the junction of the two conductors) and the "cold junction" (the open conductor ends). Accordingly, thermocouples primarily only measure differences in temperature. The absolute temperature at the measuring point can be determined from these, if the associated temperature at the cold junction is known or is measured separately and compensated for. The material combinations and associated thermoelectric voltage/temperature characteristics of the most common types of thermocouple are standardized in the IEC 60584 and ASTM E230/ANSI MC96.1 standards.

---

### Equipment architecture

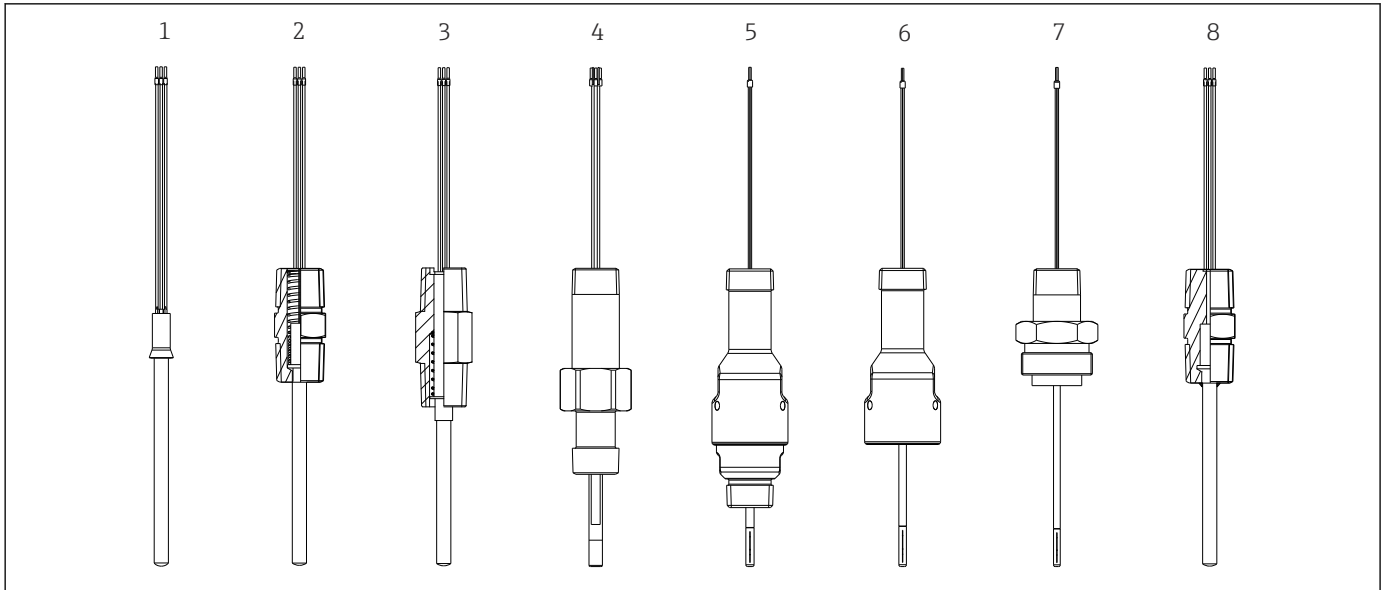

A0033503

1 iTHERM TS212 insert design overview for all neck options

- 1 Insert without nipple
- 2 Insert with Hex nipple
- 3 Insert with Lamination nipple
- 4 Insert with Nipple-Union-Nipple
- 5 Insert with iTHERM QuickNeck NPT 1/2"
- 6 Insert with iTHERM QuickNeck upper half
- 7 Insert with UNEF Hex nipple
- 8 Insert with fixed nipple (spare part for Dual Seal metal sealing)

## Input

**Measured variable** Temperature

**Measuring range**

*RTD resistance thermometers*

Sensor type	Measuring range	Connection type	Temperature-sensitive length
Pt100 (TF) iTHERM StrongSens	-50 to +500 °C (-58 to +932 °F)	3- or 4-wire	7 mm (0.27 in)
Pt100 (TF) iTHERM® QuickSens	-50 to +200 °C (-58 to +392 °F)	3- or 4-wire	5 mm (0.20 in)
Pt100 (WW)	-200 to +600 °C (-328 to +1 112 °F)	3- or 4-wire	10 mm (0.39 in)
Pt100 (TF) Basic	-50 to +200 °C (-58 to +392 °F)	3- or 4-wire	10 mm (0.39 in)

*TC thermocouples:*

Sensor type	Measuring range	Connection type	Temperature-sensitive length
Thermocouple type K	-40 to +1 100 °C (-40 to +2 012 °F)	Grounded or insulated connection	Insert length
Thermocouple type J	-40 to +750 °C (-40 to +1 382 °F)	Grounded or insulated connection	Insert length
Thermocouple type N	-40 to +1 100 °C (-40 to +2 012 °F)	Grounded or insulated connection	Insert length

**Cable resistance**

Sensor type	Insert diameter	Cable resistance in $\Omega$ /m (3.28 ft)	Connection type
Pt100 (TF) iTHERM StrongSens <sup>1)</sup>	$\varnothing$ 6 mm (0.24 in)	3 $\Omega$	3- or 4-wire
Pt100 (TF) iTHERM QuickSens	$\varnothing$ 6 mm (0.24 in)	3 $\Omega$	3- or 4-wire
	$\varnothing$ 3 mm (0.12 in)	0.2 $\Omega$	3- or 4-wire
1x thin film (TF)	$\varnothing$ 6.35 mm ( $\frac{1}{4}$ in)	0.07 $\Omega$	3- or 4-wire
2x thin film (TF)	$\varnothing$ 6.35 mm ( $\frac{1}{4}$ in)	0.07 $\Omega$	2x3-wire
1x wire-wound (WW)	$\varnothing$ 6.35 mm ( $\frac{1}{4}$ in)	0.6 $\Omega$	3- or 4-wire
2x wire-wound (WW)	$\varnothing$ 6.35 mm ( $\frac{1}{4}$ in)	0.6 $\Omega$	2x3-wire
1x wire-wound (WW)	$\varnothing$ 3 mm (0.12 in)	0.03 $\Omega$	3- or 4-wire
2x wire-wound (WW)	$\varnothing$ 3 mm (0.12 in)	0.17 $\Omega$	2x3-wire

1) We recommend to use a 3- or 4-wire measurement. If using a 2-wire measurement the resistance of the wires will influence the measured value.

 Values for single wire resistance and room temperature 20 °C (68 °F)

 Use of a 3- or 4-wire measurement is recommended. With a 2-wire measurement, the resistance of the wires affects the measured value.

## Output

**Output signal**

Generally, the measured value can be transmitted in one of two ways:

- Directly-wired sensors - sensor measured values forwarded without a transmitter.
- Via all of the usual protocols by selecting an appropriate Endress+Hauser iTEMP temperature transmitter. All the transmitters listed below are mounted directly in the washer of the insert and wired with the sensory mechanism. This part of the insert is later inserted into the terminal head of the thermometer.

## Family of temperature transmitters

Thermometers fitted with iTEMP transmitters are an installation-ready complete solution to improve temperature measurement by significantly increasing measurement accuracy and reliability, when compared to direct wired sensors, as well as reducing both wiring and maintenance costs.

### 4 to 20 mA head transmitters

They offer a high degree of flexibility, thereby supporting universal application with low inventory storage. The iTEMP transmitters can be configured quickly and easily at a PC. Endress+Hauser offers free configuration software which can be downloaded from the Endress+Hauser Website.

### HART® head transmitters

The transmitter is a 2-wire device with one or two measuring inputs and one analog output. The device not only transfers converted signals from resistance thermometers and thermocouples, it also transfers resistance and voltage signals using HART® communication. Swift and easy operation, visualization and maintenance using universal configuration software like FieldCare, DeviceCare or FieldCommunicator 375/475. Integrated Bluetooth® interface for the wireless display of measured values and configuration via Endress+Hauser SmartBlue (app), optional.

### PROFIBUS® PA head transmitters

Universally programmable head transmitter with PROFIBUS® PA communication Conversion of various input signals into digital output signals High measurement accuracy over the complete ambient temperature range PROFIBUS PA functions and device-specific parameters are configured via fieldbus communication.

### FOUNDATION Fieldbus™ head transmitters

Universally programmable head transmitter with FOUNDATION Fieldbus™ communication Conversion of various input signals into digital output signals High measurement accuracy over the complete ambient temperature range All transmitters are approved for use in all the main process control systems. The integration tests are performed in Endress+Hauser's 'System World'.

### Head transmitter with PROFINET® and Ethernet-APL

The temperature transmitter is a 2-wire device with two measuring inputs. The device not only transfers converted signals from resistance thermometers and thermocouples, it also transfers resistance and voltage signals using the PROFINET® protocol. Power is supplied via the 2-wire Ethernet connection according to IEEE 802.3cg 10Base-T1. The transmitter can be installed as an intrinsically safe electrical apparatus in Zone 1 hazardous areas. The device can be used for instrumentation purposes in the terminal head form B (flat face) according to DIN EN 50446.

### Head transmitter with IO-Link

The temperature transmitter is an IO-Link device with a measurement input and an IO-Link interface. It offers a configurable, simple and cost-effective solution thanks to digital communication via IO-Link. The device is mounted in a terminal head form B (flat face) as per DIN EN 5044.

Advantages of the iTEMP transmitters:

- Dual or single sensor input (optionally for certain transmitters)
- Attachable display (optionally for certain transmitters)
- Unsurpassed reliability, accuracy and long-term stability in critical processes
- Mathematical functions
- Monitoring of the thermometer drift, sensor backup functionality, sensor diagnostic functions
- Sensor-transmitter-matching for dual-channel transmitters, based on the Callendar van Dusen coefficients (CvD)

## Power supply

### Electrical connection



The connecting cables of the sensors are fitted with cable lugs. The cable lugs have a nominal diameter of 1.3 mm.

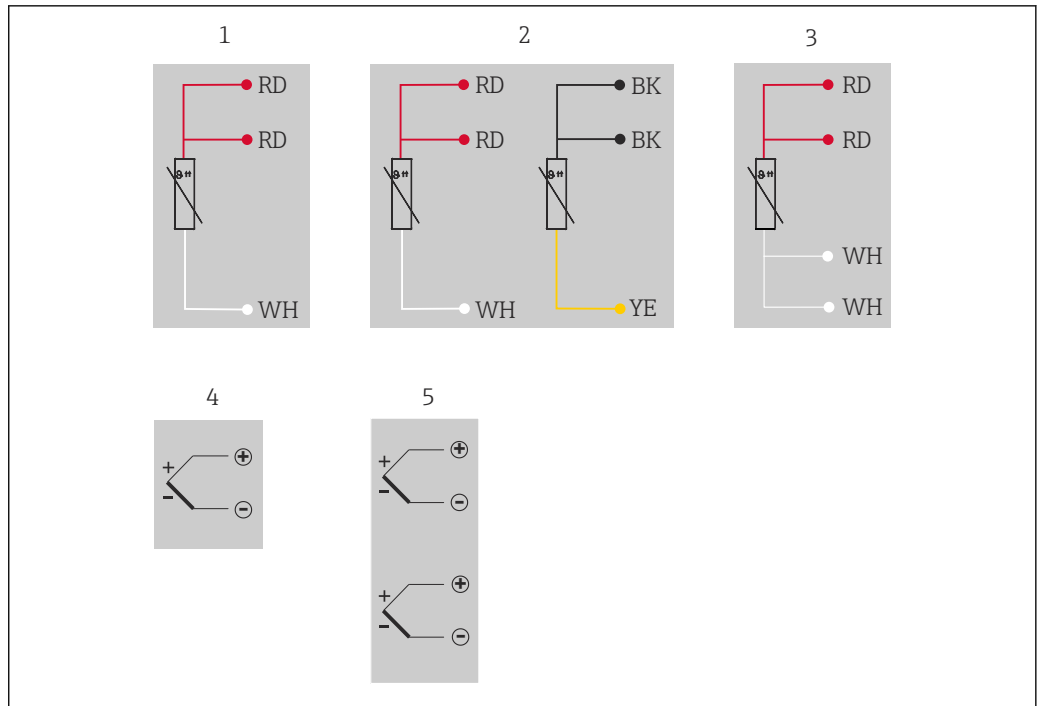

A0045596

- 1 1x RTD, 3-wire
- 2 2x RTD, 3-wire
- 3 1x RTD, 4-wire
- 4 1x TC
- 5 2x TC

## Performance characteristics

Maximum measured error      RTD resistance thermometer as per IEC 60751:

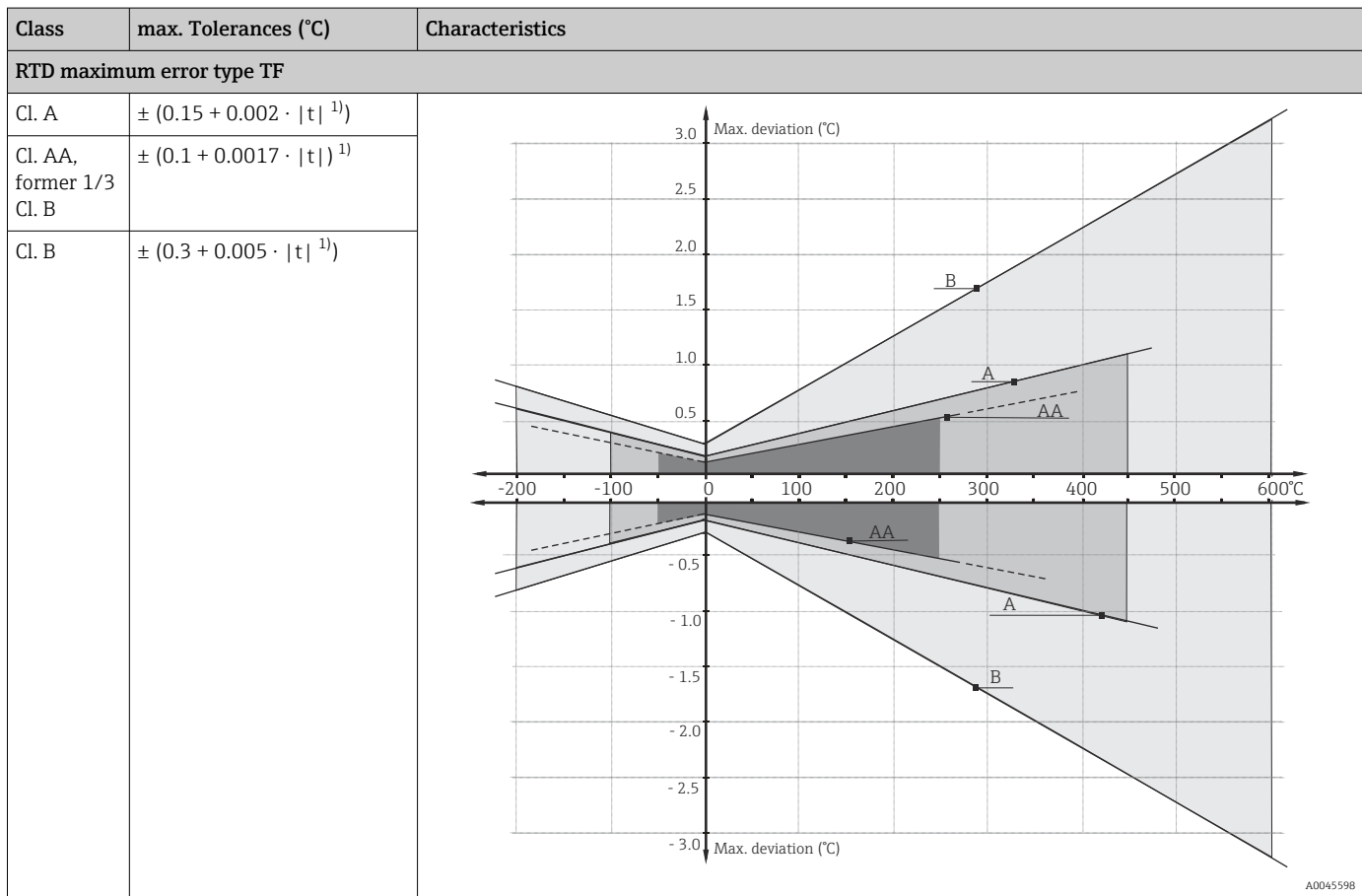

1)  $|t|$  = absolute value °C

**i** For measurement errors in °F, calculate using equations in °C, then multiply the outcome by 1.8.

### Temperature ranges

Sensor type <sup>1)</sup>	Operating temperature range	Class B	Class A	Class AA
Pt100 (TF) Basic	-50 to +200 °C (-58 to +392 °F)	-50 to +200 °C (-58 to +392 °F)	-30 to +200 °C (-22 to +392 °F)	-
Pt100 (TF) Standard	-50 to +400 °C (-58 to +752 °F)	-50 to +400 °C (-58 to +752 °F)	-30 to +250 °C (-22 to +482 °F)	0 to +150 °C (32 to 302 °F)
Pt100 (TF) iTHERM QuickSens	-50 to +200 °C (-58 to +392 °F)	-50 to +200 °C (-58 to +392 °F)	-30 to +200 °C (-22 to +392 °F)	0 to +150 °C (32 to 302 °F)
Pt100 (TF) iTHERM StrongSens	-50 to +500 °C (-58 to +932 °F)	-50 to +500 °C (-58 to +932 °F)	-30 to +300 °C (-22 to +572 °F)	0 to +150 °C (+32 to +302 °F)
Pt100 (WW)	-200 to +600 °C (-328 to +1 112 °F)	-200 to +600 °C (-328 to +1 112 °F)	-100 to +450 °C (-148 to +842 °F)	-50 to +250 °C (-58 to +482 °F)

1) Selection depending on product and configuration



TC thermocouples: Permitted deviation limits of thermoelectric voltages from standard characteristic for thermocouples as per IEC 60584 and ASTM E230/ANSI MC96.1:

Standard	Type	Standard tolerance	Special tolerance
ASTM E230/ANSI MC96.1		Deviation, the larger respective value applies	
	J (Fe-CuNi)	$\pm 2.2 \text{ }^\circ\text{C}$ or $\pm 0.0075  t $ <sup>1)</sup> (0 to 760 °C)	$\pm 1.1 \text{ }^\circ\text{C}$ or $\pm 0.004  t $ <sup>1)</sup> (0 to 760 °C)
	K (NiCr-NiAl) N (NiCrSi-NiSi)	$\pm 2.2 \text{ }^\circ\text{C}$ or $\pm 0.0075  t $ <sup>1)</sup> (0 to 1260 °C)	$\pm 1.1 \text{ }^\circ\text{C}$ or $\pm 0.004  t $ <sup>1)</sup> (0 to 1260 °C)

1) |t| = absolute temperature value in °C

### Self-heating

RTD elements are passive resistance temperature sensors, which must be supplied with a measuring current in order to determine the measured values. This measurement current causes a self-heating effect in the RTD element itself which in turn creates an additional measurement error. The extent of this measurement error is influenced not only by the measuring current but also by the temperature conductivity and the thermal coupling of the resistance sensor with the environment. This self-heating error is negligible when an Endress+Hauser iTHERM temperature transmitter (very low measured current) is used.

Sensor type	Diameter ID	Typical values for self-heating (measured in water at 20 °C)
Pt100 (TF) iTHERM StrongSens	Ø6 mm (0.24 in)	$\leq 25 \text{ m}\Omega/\text{mW}$ or $\leq 64 \text{ mK}/\text{mW}$
Pt100 (TF) iTHERM QuickSens	Ø3 mm (0.12 in)	13 mΩ/mW or 35 mK/mW
	Ø6 mm (0.24 in)	11.5 mΩ/mW or 30 mK/mW
Pt100 (WW)	Ø3 mm (0.12 in)	15 mΩ/mW or 39 mK/mW
	Ø6.35 mm (¼ in)	50 mΩ/mW or 130 mK/mW
Pt100 (TF) Basic	Ø6.35 mm (¼ in)	57 mΩ/mW or 149 mK/mW

### Response time

RTD resistance thermometers tested in accordance with IEC 60751 in flowing water (0.4 m/s at 30 °C):

Insert			
Sensor type	Diameter ID	Response time	
Pt100 (TF) iTHERM StrongSens	Ø6 mm (0.24 in)	t <sub>50</sub>	< 5.5 s
		t <sub>90</sub>	< 16 s
Pt100 (TF) iTHERM QuickSens	Ø3 mm (0.12 in)	t <sub>50</sub>	< 0.5 s
		t <sub>90</sub>	< 1.2 s
	Ø6 mm (0.24 in)	t <sub>50</sub>	< 0.5 s
		t <sub>90</sub>	< 1.5 s
Pt100 (WW)	Ø3 mm (0.12 in)	t <sub>50</sub>	< 2 s
		t <sub>90</sub>	< 5 s
	Ø6.35 mm (¼ in) single sensor	t <sub>50</sub>	< 4 s
		t <sub>90</sub>	< 10.5 s
Ø6.35 mm (¼ in) double sensor	t <sub>50</sub>	< 4.5 s	
	t <sub>90</sub>	< 12 s	
Pt100 (TF) Basic	Ø6.35 mm (¼ in) single sensor	t <sub>50</sub>	< 6.5 s
		t <sub>90</sub>	< 15.5 s
	Ø6.35 mm (¼ in) double sensor	t <sub>50</sub>	< 9.5 s
		t <sub>90</sub>	< 22.5 s

TC thermocouples:

Insert			
Sensor type	Diameter ID	Response time	
Thermocouples (K, J and N)	Ø3 mm (0.12 in)	t <sub>50</sub>	1 s
		t <sub>90</sub>	3 s
	Ø6.35 mm (1/4 in)	t <sub>50</sub>	2.5 s
		t <sub>90</sub>	6 s



Response time for insert without transmitter.

## Calibration

### Calibration of thermometers

Calibration involves comparing the measured values of a device under test (DUT) with those of a more precise calibration standard using a defined and reproducible measurement method. The aim is to determine the deviation of the DUT's measured values from the true value of the measured variable. Two different methods are used for thermometers:

- Calibration at fixed-point temperatures, e.g. at the freezing point of water at 0 °C,
- Calibration compared against a precise reference thermometer.

The thermometer to be calibrated must display the fixed point temperature or the temperature of the reference thermometer as accurately as possible. Temperature-controlled calibration baths with very homogeneous thermal values, or special calibration furnaces into which the DUT and the reference thermometer, where necessary, can project to a sufficient degree, are typically used for thermometer calibrations.

The measurement uncertainty can increase due to heat dissipation errors and short immersion lengths. The existing measurement uncertainty is listed on the individual calibration certificate.

For accredited calibrations according to ISO17025, the measurement uncertainty shouldn't be twice as high as the accredited measurement uncertainty. If this is exceeded, only a factory calibration can be performed.

### Sensor transmitter matching

The resistance/temperature curve of platinum resistance thermometers is standardized but in practice it is rarely possible to keep to the values precisely over the entire operating temperature range. For this reason, platinum resistance sensors are divided into tolerance classes, such as Class A, AA or B as per IEC 60751. These tolerance classes describe the maximum permissible deviation of the specific sensor characteristic curve from the standard curve, i.e. the maximum temperature-dependent characteristic error that is permitted. The conversion of measured sensor resistance values to temperatures in temperature transmitters or other meter electronics is often susceptible to considerable errors as the conversion is generally based on the standard characteristic curve.

When using Endress+Hauser temperature transmitters, this conversion error can be reduced significantly by sensor-transmitter matching

- Calibration at several temperatures and determination of the actual temperature sensor characteristic curve,
- adjustment of the sensor-specific polynomial function using Calendar-van Dusen (CvD) coefficients,
- configuration of the temperature transmitter with the sensor-specific CvD coefficients for resistance/temperature conversion, and
- optionally another calibration of the reconfigured temperature transmitter with connected resistance thermometer.

Endress+Hauser offers this kind of sensor-transmitter matching as a separate service. Furthermore, the sensor-specific polynomial coefficients of platinum resistance thermometers are always provided on every Endress+Hauser calibration certificate so that users themselves can also appropriately configure suitable temperature transmitters.

For the device, Endress+Hauser offers standard calibrations at a reference temperature of -20 to +500 °C (-4 to +932 °F) based on the ITS90 (International Temperature Scale). Calibrations in other temperature ranges are available from your Endress+Hauser sales center on request.

Calibrations are traceable to national and international standards. The calibration certificate is referenced to the serial number of the device. Only the insert is calibrated.

### Minimum insertion length (IL) for inserts required to perform a correct calibration

Due to restrictions of the bath geometries, minimum insertion lengths must be maintained at high temperatures in order to be able to perform a calibration with acceptable measurement uncertainty. The same applies when a temperature head transmitter is used. Due to the heat dissipation, minimum insertion lengths must be maintained in order to ensure the functionality of the transmitter -40 to +85 °C (-40 to +185 °F).

*Minimum insertion length (IL):*

Calibration temperature	Minimum insertion length (IL)
-196 °C (-320.8 °F)	120 mm (4.72 in) <sup>1)</sup>
-80 to +250 °C (-112 to +482 °F)	No minimum insertion length needed <sup>2)</sup>

Calibration temperature	Minimum insertion length (IL)
251 to 550 °C (483 to 1022 °F)	300 mm (11.8 in)
551 to 600 °C (1023 to 1112 °F)	400 mm (15.8 in)

- 1) Min. 150 mm (5.91) required with iTEMP head transmitters
- 2) At a temperature of -80 to +250 °C (-112 to +482 °F) and with iTEMP head transmitters, min. 50 mm (1.97 in) is required

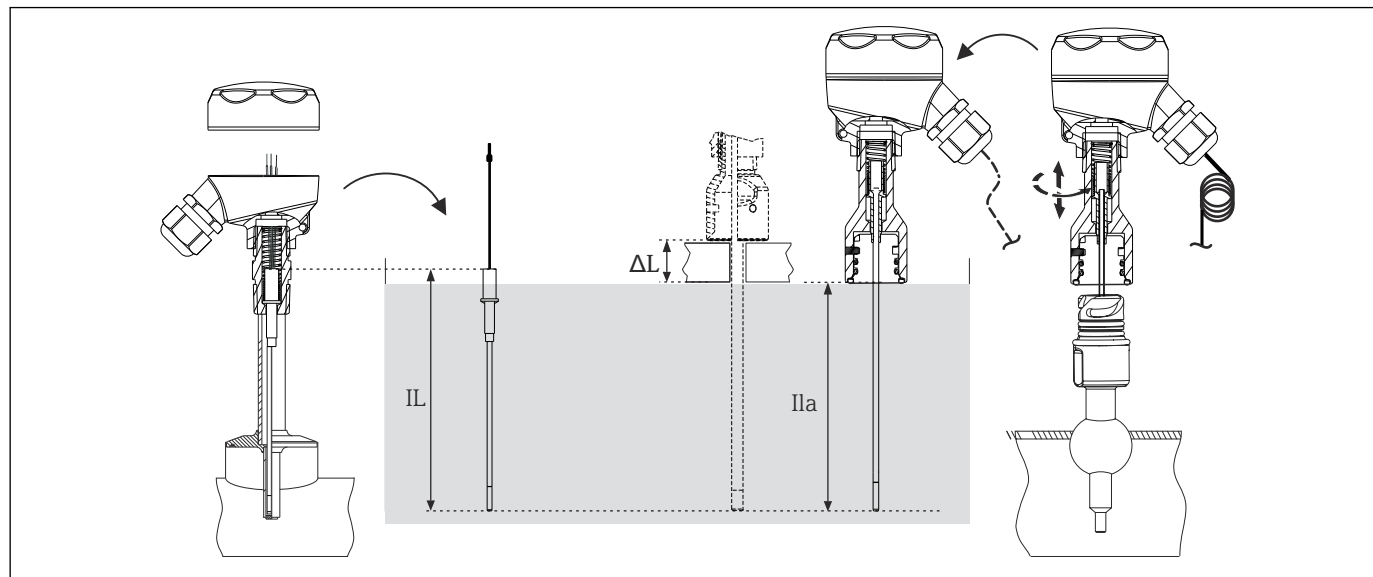

2 Insertion lengths for sensor calibration

IL Insertion length for factory calibration or recalibration onsite without the iTHERM QuickNeck extension neck

ILa Insertion length for recalibration onsite with the iTHERM QuickNeck extension neck

ΔL Additional length, depending on the calibration unit, if the insert cannot be fully immersed

- To check the actual accuracy rating of the thermometers installed, a cyclic calibration of the installed sensor needs to be performed frequently. The insert is normally removed for comparison with a precise reference thermometer in the calibration bath (see graphic, left part).
- The iTHERM QuickNeck enables quick, tool-free removal of the insert for calibration purposes. The entire upper part of the thermometer is released by turning the terminal head. The insert is removed from the thermowell and directly immersed into the calibration bath (see graphic, right part). Make sure that the cable is long enough to be able to reach the mobile calibration bath with the cable connected. If this is not possible for the calibration, it is advisable to use a connector.

Advantages of iTHERM QuickNeck:

- Considerable time savings when recalibrating the device (up to 20 minutes per measuring point)
- Wiring mistakes avoided when re-installing
- Minimum plant downtime, thereby saving costs

Formulas for calculating the ILa when recalibrating onsite with iTHERM QuickNeck <sup>1)</sup>

Thermowell version	Formula
Thermowell diameter Ø6.35 mm (¼ in)	ILa = U + T + 19.05 mm (0.75 in)
Thermowell diameter Ø9.53 mm (⅜ in)	
Thermowell diameter Ø12.7 mm (½ in)	

1) Spring load of the insert ½ in

**Insulation resistance**

**RTD resistance thermometers**

Insulation resistance as per IEC 60751 with a minimum test voltage of 100 V DC:  
 >100 MΩ at 25 °C

**TC thermocouples**

Insulation resistance as per DIN EN 60584 between the connecting wires and the sheath material with a minimum test voltage of 500 V DC:

- >1 GΩ at 25 °C
- >5 MΩ at 500 °C

**Dielectric strength**

Dielectric strength between terminals and insert sheath (for RTD only):

- For all Ø6 mm (0.24 in) or 6.35 mm (¼ in) inserts: ≥ 1 000 V DC for 5 s
- For Ø3 mm (0.12 in) QuickSens: ≥ 500 V DC for 5 s
- For all other Ø3 mm (0.12 in) inserts: ≥ 250 V DC for 5 s

## Installation

**Orientation**

No restrictions.

**Installation instructions**

The insert should be mounted in thermowells with NPT 1/2" thread, UNEF thread or iTHERM QuickNeck connection. The sensor has spring-loading to ensure that the tip is pressed against the bottom of the thermowell for good thermal contact.

**Immersion length**

**RTD resistance thermometers:**

*Error caused by heat conduction ≤ 0.1 K; measured according to IEC 60751 at 100 °C in liquid medium*

Sensor type	Diameter ID	Immersion length
Pt100 (TF) iTHERM StrongSens	Ø6 mm (0.24 in)	≥ 40 mm (1.57 in)
Pt100 (TF) iTHERM QuickSens	Ø3 mm (0.12 in)	≥ 25 mm (0.98 in)
	Ø6 mm (0.24 in)	
Pt100 (WW)	Ø3 mm (0.12 in)	≥ 60 mm (2.36 in)
	Ø6 mm (0.24 in)	
Pt100 (WW)	Ø6.35 mm (¼ in)	≥ 60 mm (2.36 in)
Pt100 (TF) Basic	Ø6.35 mm (¼ in)	≥ 50 mm (1.97 in)

**TC thermocouples:**

Sensor type	Diameter ID	Immersion length
Thermocouples, type K and J	Ø6.35 mm (¼ in)	30 mm (1.18 in)
Thermocouples, type N	Ø6 mm (0.24 in)	30 mm (1.18 in)
Thermocouples, type N	Ø3 mm (0.12 in)	30 mm (1.18 in)

**Delivery condition**

Inserts with an immersion length of IL > 1 000 mm (48 in) are coiled when delivered. You will receive instructions with the insert detailing how to straighten the coiled insert.

*Possible bending radius*

Sensor type	Diameter ID	Bending radius R	Non-bendable length (tip) NL <sub>1)</sub>
Pt100 (TF) iTHERM StrongSens	Ø6 mm (0.24 in)	R ≥ 3 x ID	30 mm (1.18 in)
Pt100 (TF) iTHERM QuickSens	Ø3 mm (0.12 in)	non-bendable	non-bendable
	Ø6 mm (0.24 in)	R ≥ 3 x ID	30 mm (1.18 in)

Sensor type	Diameter ID	Bending radius R	Non-bendable length (tip) NL <sup>1)</sup>
Pt100 (WW)	Ø6.35 mm (¼ in)	R ≥ 3 x ID	30 mm (1.18 in)
	Ø6 mm (0.24 in)		
	Ø3 mm (0.12 in)		
Pt100 (TF) Basic	Ø6 mm (0.24 in) Ø6.35 mm (¼ in)	non-bendable	non-bendable
Thermocouples, type J, K, N	Ø6.35 mm (¼ in)	R ≥ 3 x ID	30 mm (1.18 in)
	Ø3 mm (0.12 in)		
	Ø6 mm (0.24 in)		

1) If a sleeve is overlapped, NL increases to 80 mm.

Inserts with an insertion length IL > 1 000 mm (39.4 in) are coiled when delivered. You will receive instructions with the insert detailing how to replace the rolled insert.

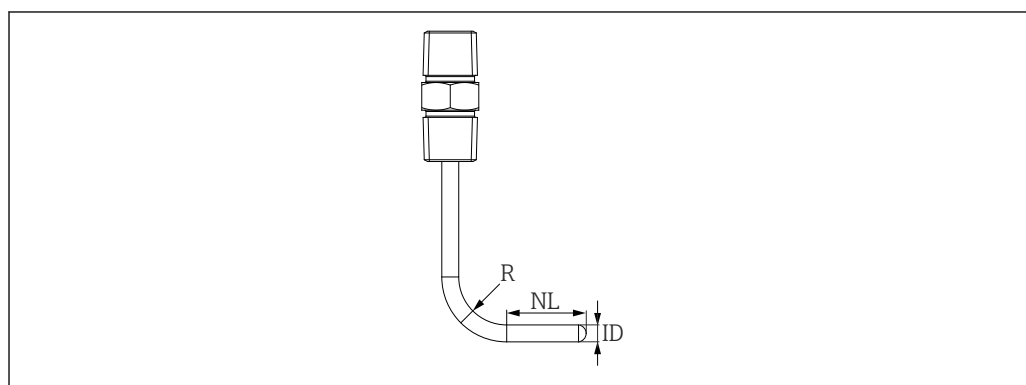

A0039499

## Environment

### Ambient temperature range

Terminal head	Temperature in °C (°F)
Without head transmitter installed	Depends on the terminal head used and the cable gland or fieldbus connector
With mounted head transmitter	-40 to +85 °C (-40 to +185 °F)
With mounted head transmitter and display	-20 to +70 °C (-4 to +158 °F)

### Vibration resistance

RTD resistance thermometers:

The Endress+Hauser inserts exceed the requirements of IEC 60751, which specify shock and vibration resistance of 3 g in the range from 10 to 500 Hz.

*The vibration resistance at the measuring point depends on the sensor type and design, see the following table:*

Sensor type	Vibration resistance for the sensor tip <sup>1)</sup>
Pt100 (TF) iTHERM StrongSens (vibration-resistant)	≤ 600 m/s <sup>2</sup> (≤ 60g)
Pt100 (TF) iTHERM QuickSens	3 mm (0.12 in) ≤ 3g 6 mm (0.24 in) ≤ 60g
Pt100 (WW)	≤ 3g

Sensor type	Vibration resistance for the sensor tip <sup>1)</sup>
Pt100 (TF) Basic	≤ 3g
Thermocouples, type K, J, N (based on IEC 60751)	≤ 3g

1) (measured according to IEC 60751 with varying frequencies in the range of 10 to 500 Hz)

**Shock resistance** ≥ 4 J (measured according to IEC 60079-0)

## Mechanical construction

### Design, dimensions

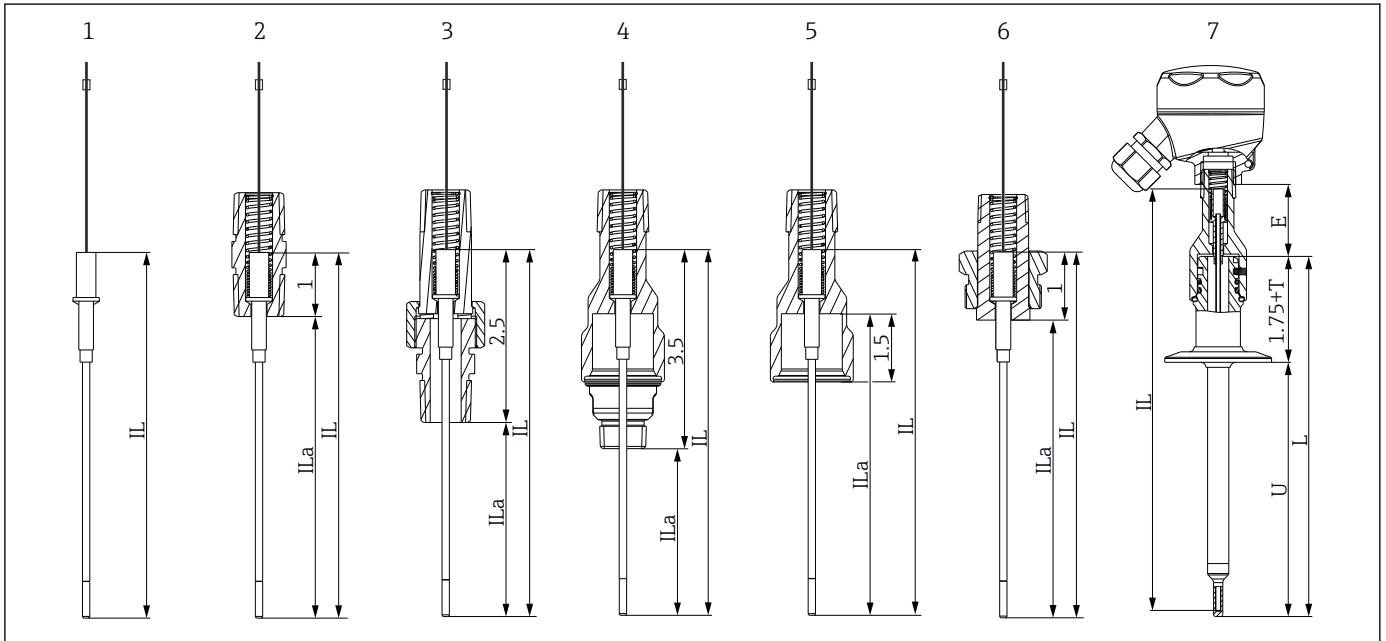

3 Design of the iTHERM TS212

- 1 Insert without nipple
  - 2 Insert with Hex. nipple NPT ½"
  - 3 Insert with Nipple-Union-Nipple NPT ½"
  - 4 Insert with iTHERM QuickNeck NPT ½"
  - 5 Insert with iTHERM QuickNeck (upper half), to mount in existing thermowell with iTHERM Quick Neck
  - 6 Insert with Hex. nipple NPT ½" - 1 ¼" x 18 UNEF
  - 7 Complete thermometer TM412 with iTHERM QuickNeck NPT ½", neck separable - quick release to mount in existing thermowell
- E Extension neck length  
 T Neck length of the thermowell  
 U Immersion length of the thermowell  
 L Thermowell length  
 IL Insert length  
 ILa Insertion length (insert length below nipple)

The prerequisite is that the insert length (IL) must be adapted to the thermowell. This can be calculated by means of the following formula:  $IL = U + T + E + 38.1 \text{ mm (1.5 in.)}$ .

The insert comprises of three main components: the sensor at the tip, a mineral insulated sheathed cable or stainless steel tube with insulated wires in between and a neck. In the measuring tip, the sensor element is (depending on the sensor type) either firmly embedded in a sensor cap by means of ceramic potting, soldered onto the bottom of the sensor cap or embedded in compressed mineral insulation.

**There are two different designs available for thermocouples:**

**Grounded version:** Here, the thermocouple at the junction is mechanically and electrically connected to the inside of the sheathed cable. This results in good heat transfer from the sensor wall to the measuring tip of the thermocouple.

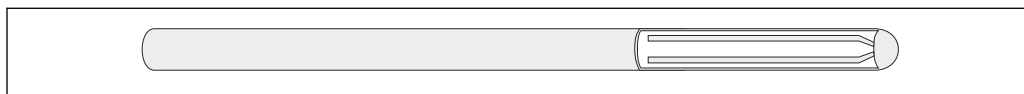

**Non-grounded version:** If the probe is not grounded, there is no connection between the thermocouple and the sensor wall. This is also referred to as an insulated measuring point. The response time is slower than in a grounded version.

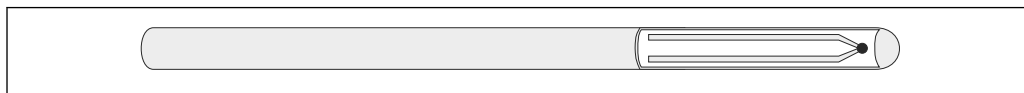

*RTD resistance thermometers:*

Sensor type	Sheathed cable, outer diameter ID; material
Pt100 (TF) iTHERM StrongSens	<p>Ø6 mm (0.24 in) The sheath is made of stainless steel and is filled with a magnesium oxide (MgO) powder. The primary sensor element is firmly potted into the sensor cap for maximum vibration resistance.</p>
Pt100 (TF) iTHERM QuickSens	<p>Ø3 mm (0.12 in)<sup>1)</sup> The sheath is made of stainless steel and the wires are PTFE isolated. The primary sensor element is soldered onto the bottom of the sensor cap for fastest response times.</p>
	<p>Ø6 mm (0.24 in) The sheath is made of stainless steel and is filled with a magnesium oxide (MgO) powder. The primary sensor element is soldered onto the bottom of the sensor cap for fastest response times.</p>
Pt100 (WW), extended measurement range	<p>Ø3 mm (0.12 in)/Ø6.35 mm (¼ in) The sheath is made of stainless steel and is filled with a magnesium oxide (MgO) powder. The primary sensor element is embedded in the insert tip with compressed MgO powder. Single or double sensor elements are available.</p>
Pt100 (TF)Basic	<p>Ø6.35 mm (¼ in) The sheath is made of stainless steel and the wires are PTFE isolated. The primary sensor element is embedded in the insert tip with compressed Al<sub>2</sub>O<sub>3</sub> powder. Single or double sensor elements are available.</p>

- 1) If the insertion length IL is > 1400 mm (55 in), the measuring insert diameter is 3 mm (0.12 in) at the sensor tip and 6 mm (0.24 in) at the top.

The spring load of the insert equals to ½ in.



The insert comes with flying leads for the electrical connection.

*TC thermocouples:*

Sensor type	Sheathed cable, outer diameter ID; material
Thermocouple type K	The type K thermocouples are available as single or double sensors. The wires made of nickel-chromium and nickel are embedded in magnesium oxide (MgO) powder within the sheathed cable made of Alloy 600. The measuring point can be insulated or grounded (electrically conductive, connected to sheathed cable).
Thermocouple type J	The type J thermocouples are available as single or double sensors. The wires made of iron and copper-nickel are embedded in magnesium oxide (MgO) powder within the sheathed cable made of stainless steel SS316L. The measuring point can be insulated or grounded (electrically conductive, connected to sheathed cable).
Thermocouple type N	The type N thermocouples are available as single or double sensors. The wires made of nickel-chromium silicon and nickel silicon are embedded in magnesium oxide (MgO) powder within the sheathed cable made of Alloy TD (Pyrosil, Nicrobell or similar). The measuring point can be insulated or grounded (electrically conductive, connected to sheathed cable). Compared to type K thermocouples, type N thermocouples are significantly less prone to what is known as "green rot".

The insert comes with free wires that can be used for direct electrical connection to a head transmitter. Alternatively, a ceramic terminal block can be used, which is mounted securely on a washer.

Neck dimensions iTHERM TS212 - all dimensions in mm (in).

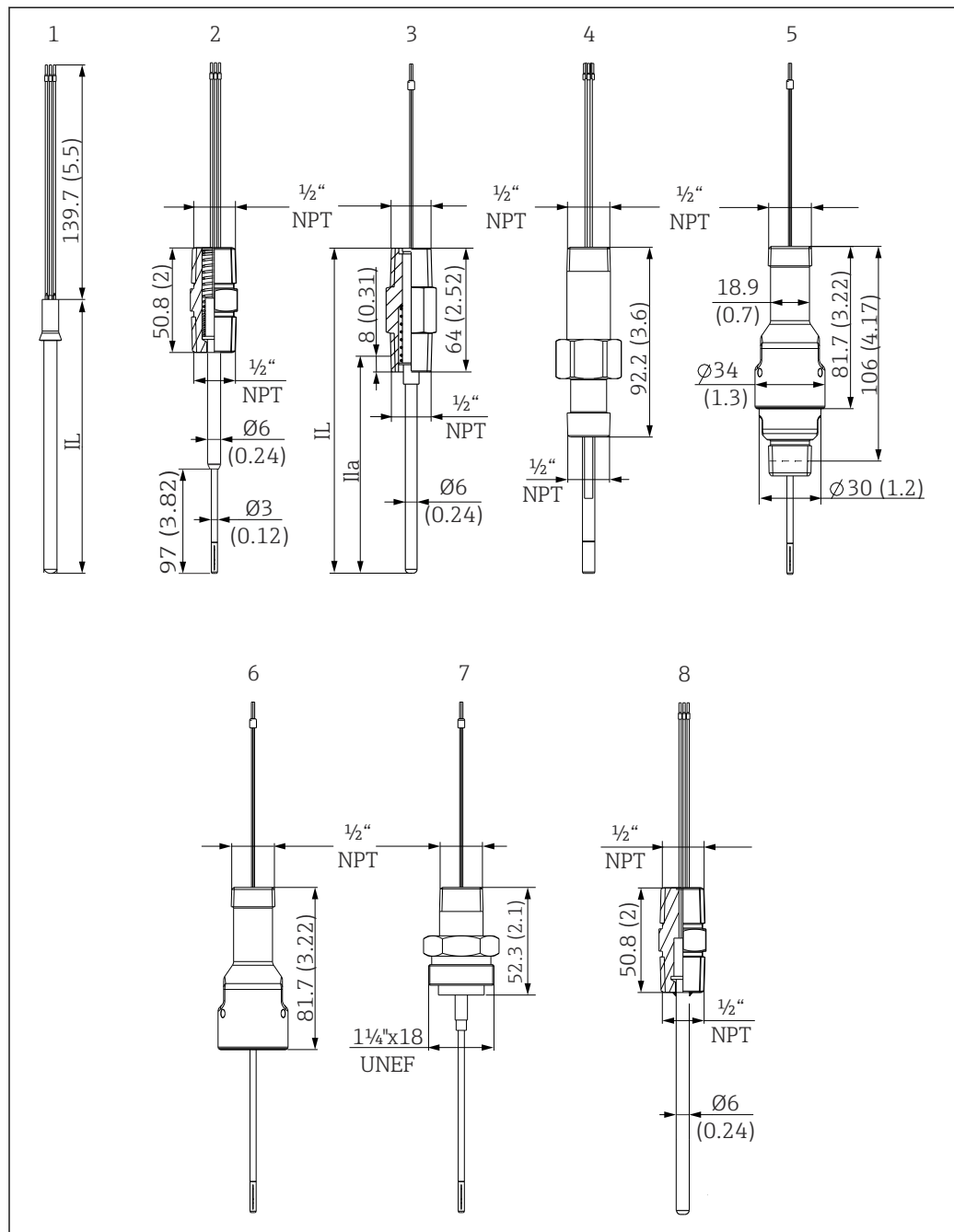

A0039556

- 1 Insert without nipple
- 2 Insert with Hex nipple
- 3 Insert with Lamination nipple
- 4 Insert with Nipple-Union-Nipple
- 5 Insert with iTHERM QuickNeck NPT 1/2"
- 6 Insert with iTHERM QuickNeck upper half
- 7 Insert with UNEF Hex nipple
- 8 Insert with fixed nipple (spare part for Dual Seal metal sealing)

**Materials**

The temperatures for continuous operation specified in the following table are intended only as reference values when using the various materials in air. In exceptional cases, the maximum operating temperatures are sometimes significantly lower.

Description	Recommended max. temperature for continuous use in air	Properties
AISI 316L	650 °C (1 202 °F)	<ul style="list-style-type: none"> <li>▪ Austenitic, stainless steel</li> <li>▪ High corrosion resistance in general</li> <li>▪ Particularly high corrosion resistance in chlorine-based and acidic, non-oxidizing atmospheres through the addition of molybdenum (e.g. phosphoric and sulfuric acids, acetic and tartaric acids with a low concentration)</li> <li>▪ Increased resistance to intergranular corrosion and pitting</li> </ul>
Alloy 600	1 100 °C (2 012 °F)	<ul style="list-style-type: none"> <li>▪ A nickel/chromium alloy with very good resistance to aggressive, oxidizing and reducing atmospheres, even at high temperatures</li> <li>▪ Resistance to corrosion caused by chlorine gases and chlorinated media as well as many oxidizing mineral and organic acids, sea water etc.</li> <li>▪ Corrosion from ultrapure water</li> <li>▪ Not to be used in sulfur-containing atmospheres</li> </ul>
Alloy TD	1 100 °C (2 012 °F)	<ul style="list-style-type: none"> <li>▪ Nickel-chromium alloy, which was designed for thermocouple sheaths</li> <li>▪ High degree of temperature corrosion resistance and robustness without the use of elements that can cause thermocouple contamination over time</li> <li>▪ Excellent resistance to nitration up to 1 177 °C (2 151 °F)</li> <li>▪ Resistant to oxide spalling</li> </ul>

## Certificates and approvals

Current certificates and approvals for the product are available at [www.endress.com](http://www.endress.com) on the relevant product page:

1. Select the product using the filters and search field.
2. Open the product page.
3. Select **Downloads**.

## Ordering information

Detailed ordering information is available from your nearest sales organization [www.addresses.endress.com](http://www.addresses.endress.com) or in the Product Configurator at [www.endress.com](http://www.endress.com):

1. Select the product using the filters and search field.
2. Open the product page.
3. Select **Configuration**.



### Product Configurator - the tool for individual product configuration

- Up-to-the-minute configuration data
- Depending on the device: Direct input of measuring point-specific information such as measuring range or operating language
- Automatic verification of exclusion criteria
- Automatic creation of the order code and its breakdown in PDF or Excel output format
- Ability to order directly in the Endress+Hauser Online Shop

## Accessories

Various accessories, which can be ordered with the device or subsequently from Endress+Hauser, are available for the device. Detailed information on the order code in question is available from your local Endress+Hauser sales center or on the product page of the Endress+Hauser website: [www.endress.com](http://www.endress.com).

## Service-specific accessories

Accessories	Description
Applicator	<p>Software for selecting and sizing Endress+Hauser devices:</p> <ul style="list-style-type: none"> <li>■ Calculation of all the necessary data for identifying the optimum device: e.g. pressure loss, accuracy or process connections.</li> <li>■ Graphic illustration of the calculation results</li> </ul> <p>Administration, documentation and access to all project-related data and parameters over the entire life cycle of a project.</p> <p>Applicator is available: Via the Internet: <a href="https://portal.endress.com/webapp/applicator">https://portal.endress.com/webapp/applicator</a></p>
Accessories	Description
Configurator	<p>Product Configurator - the tool for individual product configuration</p> <ul style="list-style-type: none"> <li>■ Up-to-the-minute configuration data</li> <li>■ Depending on the device: direct input of information specific to the measuring point, such as the measuring range or operating language</li> <li>■ Automatic verification of exclusion criteria</li> <li>■ Automatic creation of the order code and its breakdown in PDF or Excel output format</li> <li>■ Ability to order directly in the Endress+Hauser Online Shop</li> </ul> <p>The Product Configurator is available on the Endress+Hauser website: <a href="http://www.endress.com">www.endress.com</a>-&gt; Select your country -&gt; Click "Products" -&gt; Select the product using the filters and search field -&gt; Open product page -&gt; The "Configure" button to the right of the product image opens the Product Configurator.</p>

## Documentation

-  For an overview of the scope of the associated Technical Documentation, refer to the following:
- *Device Viewer* ([www.endress.com/deviceviewer](http://www.endress.com/deviceviewer)): Enter the serial number from the nameplate
  - *Endress+Hauser Operations app*: Enter serial number from nameplate or scan matrix code on nameplate.

The following documentation may be available depending on the device version ordered:

Document type	Purpose and content of the document
Technical Information (TI)	<p><b>Planning aid for your device</b></p> <p>The document contains all the technical data on the device and provides an overview of the accessories and other products that can be ordered for the device.</p>
Brief Operating Instructions (KA)	<p><b>Guide that takes you quickly to the 1st measured value</b></p> <p>The Brief Operating Instructions contain all the essential information from incoming acceptance to initial commissioning.</p>
Operating Instructions (BA)	<p><b>Your reference document</b></p> <p>These Operating Instructions contain all the information that is required in the various life cycle phases of the device: from product identification, incoming acceptance and storage, to mounting, connection, operation and commissioning, through to troubleshooting, maintenance and disposal.</p>
Description of Device Parameters (GP)	<p><b>Reference for your parameters</b></p> <p>The document provides a detailed explanation of each individual parameter. The description is aimed at those who work with the device over the entire life cycle and perform specific configurations.</p>
Safety Instructions (XA)	<p>Depending on the approval, safety instructions for electrical equipment in hazardous areas are also supplied with the device. The Safety Instructions are a constituent part of the Operating Instructions.</p> <p> Information on the Safety Instructions (XA) that are relevant for the device is provided on the nameplate.</p>
Supplementary device-dependent documentation (SD/FY)	<p>Always comply strictly with the instructions in the relevant supplementary documentation. The supplementary documentation is a constituent part of the device documentation.</p>

---



---



71644943

[www.addresses.endress.com](http://www.addresses.endress.com)

---