

Brief Operating Instructions

Liquiphant FTL63

Vibronic

HART

Point level switch for liquids specifically for the food and life sciences industries



These Brief Operating Instructions are not a substitute for the Operating Instructions pertaining to the device.

Detailed information can be found in the Operating Instructions and the additional documentation.

Available for all device versions via:

- Internet: www.endress.com/deviceviewer
- Smartphone/tablet: Endress+Hauser Operations app

1 Related documents



A0023555

2 About this document

2.1 Symbols

2.1.1 Safety symbols



This symbol alerts you to a dangerous situation. Failure to avoid this situation will result in serious or fatal injury.



This symbol alerts you to a dangerous situation. Failure to avoid this situation can result in serious or fatal injury.



This symbol alerts you to a dangerous situation. Failure to avoid this situation can result in minor or medium injury.



This symbol contains information on procedures and other facts which do not result in personal injury.

2.1.2 Electrical symbols



Ground connection

Grounded clamp, which is grounded via a grounding system.



Protective earth (PE)

Ground terminals, which must be grounded prior to establishing any other connections. The ground terminals are located on the inside and outside of the device.

2.1.3 Tool symbols



Flat-blade screwdriver



Allen key



Open-ended wrench

2.1.4 Communication-specific symbols



Bluetooth

Wireless data transmission between devices over a short distance.

2.1.5 Symbols for certain types of information



Permitted

Procedures, processes or actions that are permitted.





Forbidden

Procedures, processes or actions that are forbidden.



Tip

Indicates additional information

-  Reference to documentation
-  Reference to another section
- 1**, **2**, **3** Series of steps

2.1.6 Symbols in graphics

A, B, C ... View

1, 2, 3 ... Item numbers

 Hazardous area

 Safe area (non-hazardous area)

2.1.7 Registered trademarks

HART®

Registered trademark of the FieldComm Group, Austin, Texas, USA

Bluetooth®

The *Bluetooth®* word mark and logos are registered trademarks owned by the Bluetooth SIG, Inc. and any use of such marks by Endress+Hauser is under license. Other trademarks and trade names are those of their respective owners.

Apple®

Apple, the Apple logo, iPhone, and iPod touch are trademarks of Apple Inc., registered in the U.S. and other countries. App Store is a service mark of Apple Inc.

Android®

Android, Google Play and the Google Play logo are trademarks of Google Inc.

3 Basic safety instructions

3.1 Requirements for the personnel

The personnel must fulfill the following requirements to carry out the necessary tasks, e. g., commissioning and maintenance:

- ▶ Trained, qualified specialists must have a relevant qualification for the specific function and task
- ▶ Are authorized by the plant owner/operator
- ▶ Are familiar with federal/national regulations
- ▶ Must have read and understood the instructions in the manual and supplementary documentation
- ▶ Follow instructions and comply with conditions

3.2 Intended use

- Only use the device for liquids
- Improper use can pose hazards
- Ensure that the measuring device is free of defects while it is in operation

- Use the device only for media to which the wetted materials have an adequate level of resistance
- Do not exceed or drop below the relevant limit values for the device
 - ▣ For more details, see the Technical Documentation

3.2.1 Incorrect use

The manufacturer is not liable for damage caused by improper or non-intended use.

Residual risks

Due to heat transfer from the process, the temperature of the electronics housing and the assemblies contained therein may rise to 80 °C (176 °F) during operation.

Danger of burns from contact with surfaces!

- ▶ If necessary, ensure protection against contact to prevent burns.

For requirements concerning functional safety in accordance with IEC 61508, the associated SIL documentation must be observed.

3.3 Workplace safety

For work on and with the device:

- ▶ Wear the required personal protective equipment according to federal/national regulations.

3.4 Operational safety

Risk of injury!

- ▶ Operate the device only if it is in proper technical condition, free from errors and faults.
- ▶ The operator is responsible for ensuring the interference-free operation of the device.

Modifications to the device

Unauthorized modifications to the device are not permitted and can lead to unforeseeable dangers.

- ▶ If, despite this, modifications are required, consult with Endress+Hauser.

Repair

To ensure continued operational safety and reliability:

- ▶ Only perform repair work on the device if this is expressly permitted.
- ▶ Observe federal/national regulations pertaining to the repair of an electrical device.
- ▶ Use original spare parts and accessories from Endress+Hauser only.

Hazardous area

To eliminate danger to persons or the facility when the device is used in the hazardous area (e.g. explosion protection):

- ▶ Check the nameplate to verify whether the ordered device can be used for the intended purpose in the hazardous area.
- ▶ Observe the specifications in the separate supplementary documentation that is an integral part of this manual.

3.5 Product safety

This device is designed in accordance with good engineering practice to meet state-of-the-art safety requirements, has been tested, and left the factory in a condition in which it is safe to operate.

It meets the general safety standards and legal requirements. It also complies with the EU directives listed in the device-specific EU Declaration of Conformity. Endress+Hauser confirms this by affixing the CE mark to the device.

3.6 Functional Safety SIL (optional)

The Functional Safety Manual must be strictly observed for devices that are used in functional safety applications.

3.7 IT security



For more information, see the Operating Instructions.

4 Incoming acceptance and product identification

4.1 Incoming acceptance

Check the following during incoming acceptance:

- Are the order codes on the delivery note and the product sticker identical?
- Are the goods undamaged?
- Do the data on the nameplate match the ordering information on the delivery note?
- If required (see nameplate): are the Safety Instructions e.g. XA provided?



If one of these conditions is not met, please contact the manufacturer's sales office.

4.2 Product identification

The following options are available for identification of the device:

- Nameplate data
- Extended order code with breakdown of the device features on the delivery note
- Enter serial number from nameplates in *W@M Device Viewer* www.endress.com/deviceviewer. All of the information on the measuring device is displayed along with an overview of the scope of technical documentation provided.
- Enter the serial number on the nameplate into the *Endress+Hauser Operations app* or scan the 2-D matrix code on the nameplate with the *Endress+Hauser Operations app*

4.2.1 Nameplate

The information that is required by law and is relevant to the device is shown on the nameplate.

4.2.2 Manufacturer address

Endress+Hauser SE+Co. KG
Hauptstraße 1
79689 Maulburg, Germany
Place of manufacture: See nameplate.

4.3 Storage and transport

4.3.1 Storage conditions

Use original packaging.

Storage temperature

-40 to +80 °C (-40 to +176 °F)
Optional -50 °C (-58 °F) or -60 °C (-76 °F)

Transporting the device

- Transport the device to the measuring point in the original packaging
- Hold the device by the housing, temperature spacer, process connection or extension pipe
- Do not bend, shorten or extend the tuning fork.

5 Mounting

Mounting instructions

- Any orientation for compact version or version with a pipe length of up to 500 mm (19.7 in) approx.
- Vertical orientation from above for device with long pipe
- Minimum distance between the tuning fork and the tank wall or pipe wall: 10 mm (0.39 in)

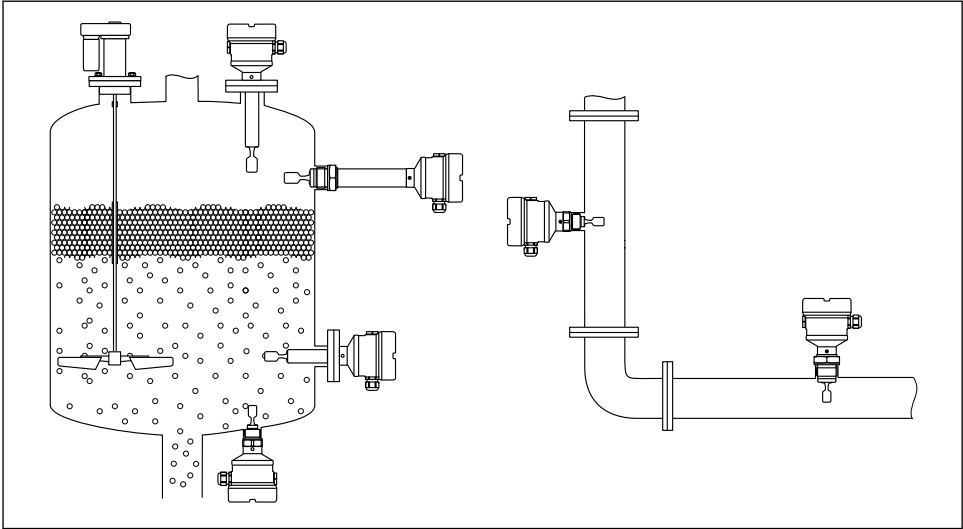

A0037879

1 Installation examples for a vessel, tank or pipe

5.1 Mounting requirements

5.1.1 Take switch point into consideration

The following are typical switch points, depending on the orientation of the point level switch.

Water +23 °C (+73 °F)

i Minimum distance between the tuning fork and the tank wall or pipe wall:
10 mm (0.39 in)

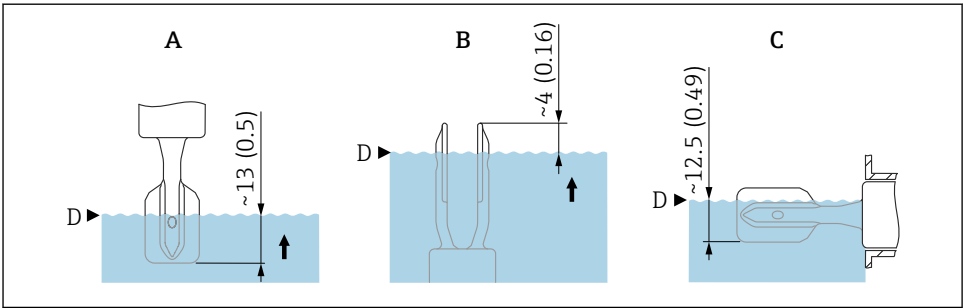

A0037915

2 Typical switch points. Unit of measurement mm (in)

- A Installation from above
- B Installation from below
- C Installation from the side
- D Switch point

5.1.2 Take viscosity into consideration



Viscosity values

- Low viscosity: < 2 000 mPa·s
- High viscosity: > 2 000 to 10 000 mPa·s

Low viscosity



It is permitted to position the tuning fork within the installation socket.

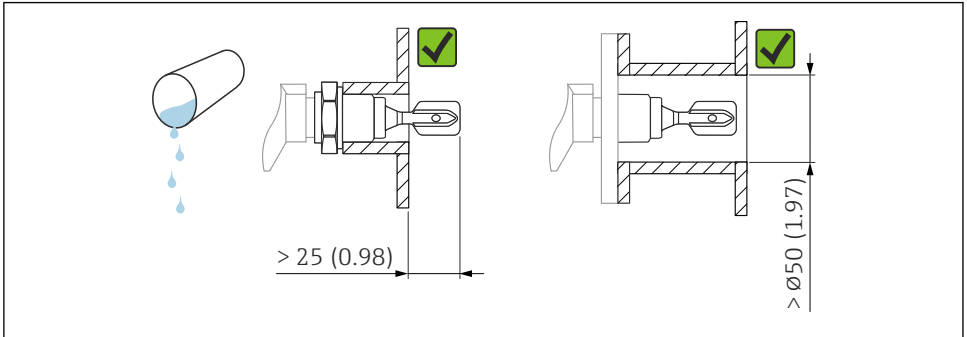

A003297

3 Installation example for low-viscosity liquids. Unit of measurement mm (in)

High viscosity

NOTICE

Highly viscous liquids may cause switching delays.

- ▶ Make sure that the liquid can run off the tuning fork easily.
- ▶ Deburr the socket surface.



The tuning fork must be located outside the installation socket!

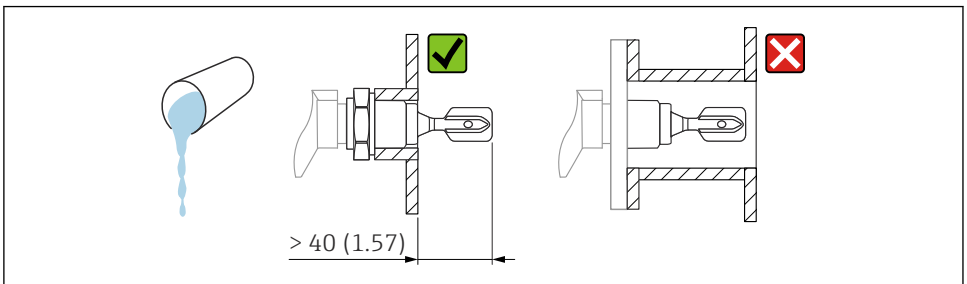

A0037348

4 Installation example for a highly viscous liquid. Unit of measurement mm (in)

5.1.3 Avoid buildup

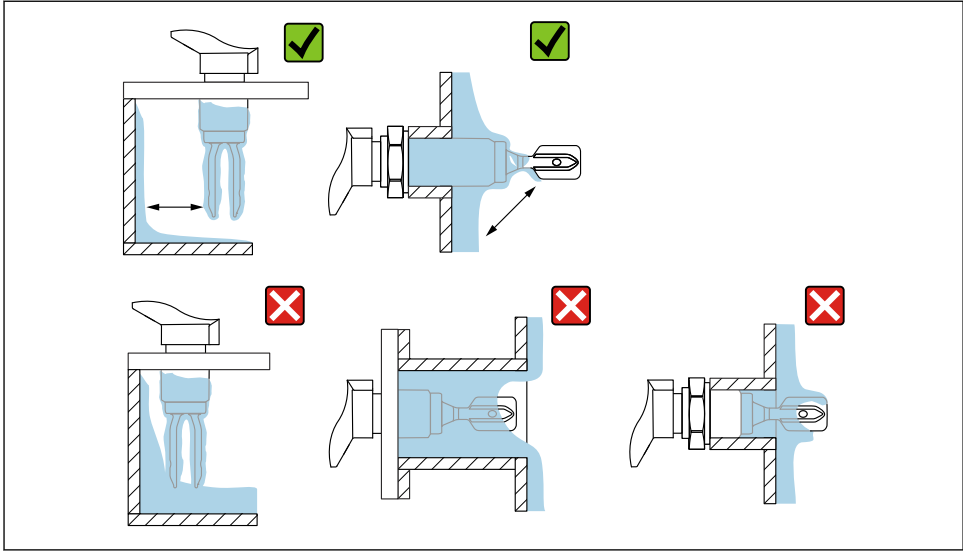

A0033239

5 Installation examples for a highly viscous process medium

5.1.4 Take clearance into consideration

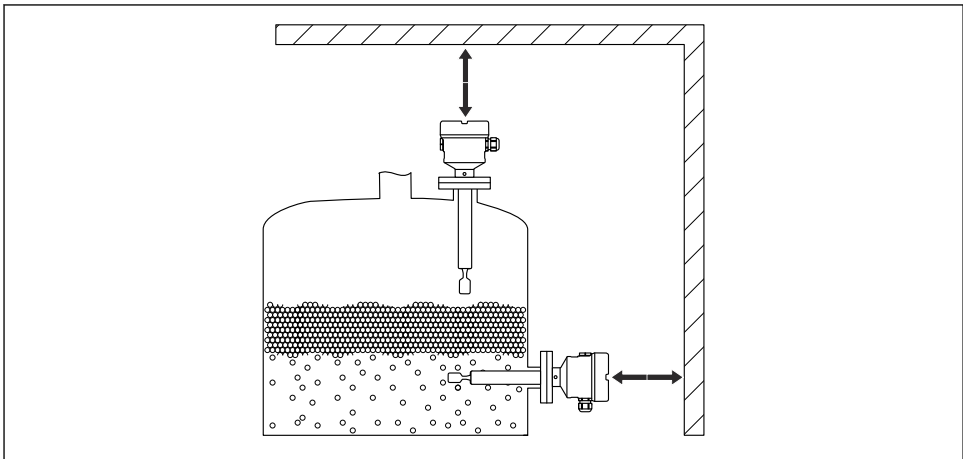

A0033236

6 Take clearance outside the tank into consideration

5.1.5 Support the device

Support the device in the event of severe dynamic load. Maximum lateral loading capacity of the pipe extensions and sensors: 75 Nm (55 lbf ft).

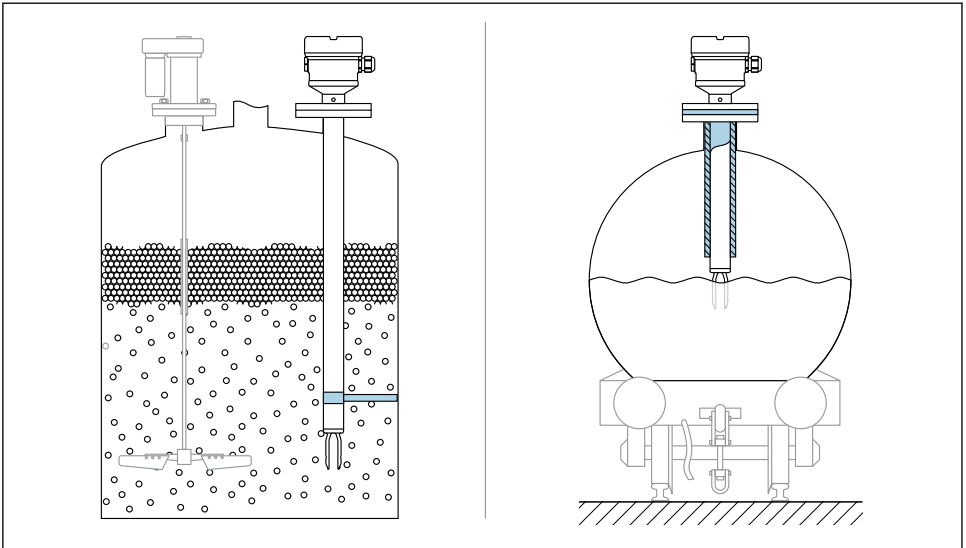

A0031874

7 Examples of support in the event of dynamic load

5.1.6 Weld-in adapter with leakage hole

Weld in the weld-in adapter in such a way that the leakage hole is pointing downwards. This enables any leaks to be detected quickly.

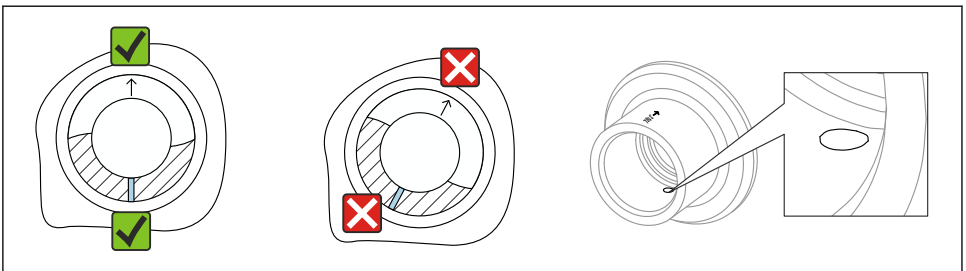

A0039230

8 Weld-in adapter with leakage hole

5.2 Mounting the device

5.2.1 Required tool

- Open-ended wrench for sensor installation
- Allen key for housing locking screw

5.2.2 Installation

Aligning the tuning fork using the marking

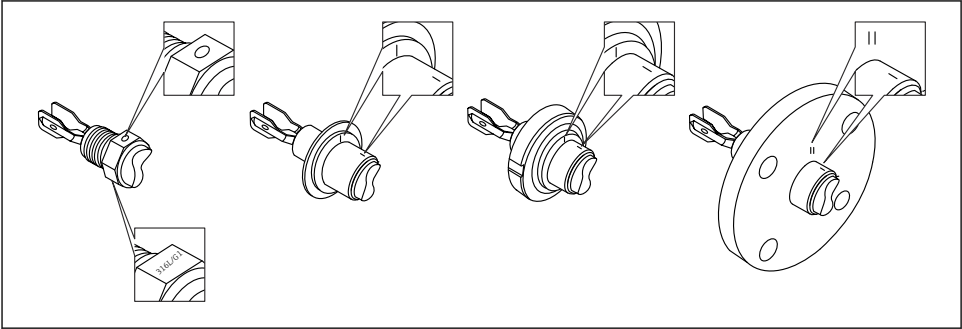

A0039125

9 Position of the tuning fork when installed horizontally in the vessel using the marking

Installing the device in piping

- Flow velocity up to 5 m/s with a viscosity of 1 mPa·s and density of 1 g/cm³ (62.4 lb/ft³) (SGU).
Check for correct functioning in the event of other process medium conditions.
- The flow will not be significantly impeded if the tuning fork is correctly aligned and the marking is pointing in the direction of flow.
- The marking is visible when installed

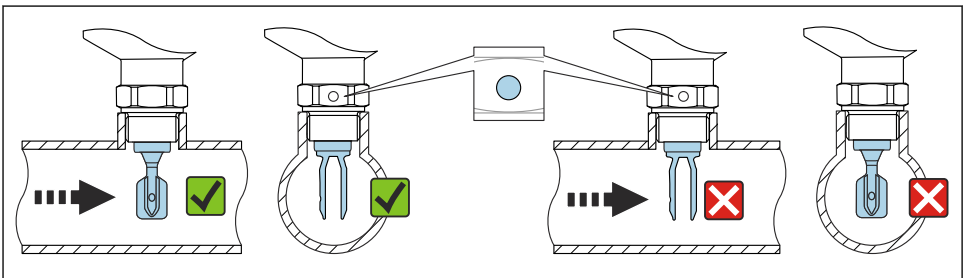

A0034851

10 Installation in pipes (take fork position and marking into consideration)

Screwing in the device

- Turn by the hex bolt only, 15 to 30 Nm (11 to 22 lbf ft)
- Do not turn at the housing!

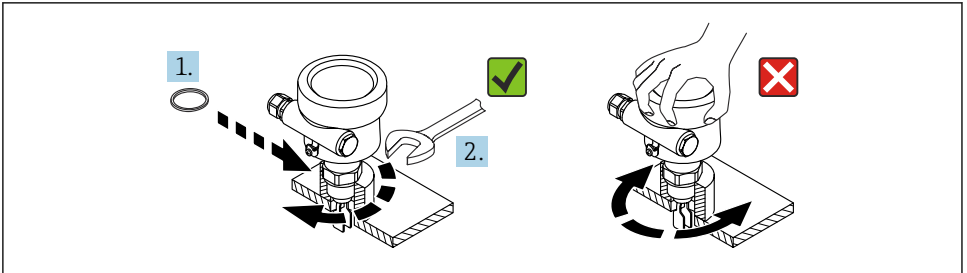

A0034852

 11 Screwing in the device

Aligning the cable entry

All housings can be aligned.

Housing without locking screw

The device housing can be rotated up to 350°.

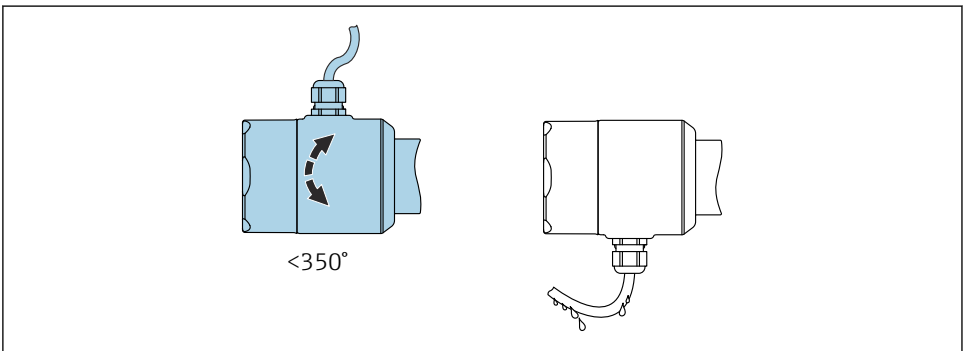

A0052359

 12 Housing without locking screw with drip loop

Housing with locking screw

-  Housings with locking screw:
 - The housing can be turned and the cable aligned by turning the locking screw.
 - The locking screw is not tightened when the device is delivered.

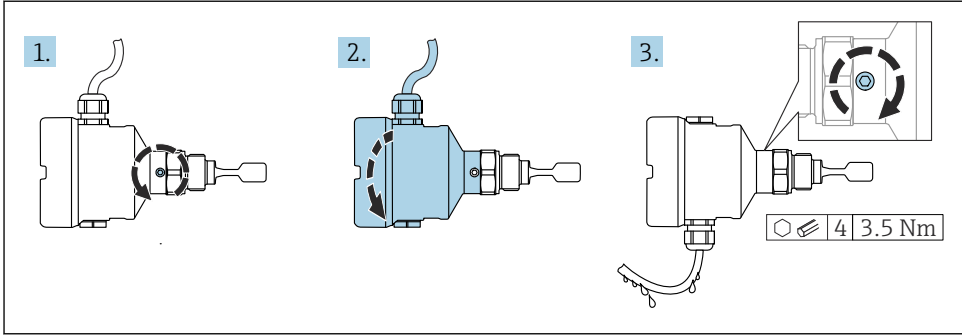

A0037347

13 Housing with external locking screw and drip loop

1. Loosen the external locking screw (maximum 1.5 turns).
2. Turn the housing, align the cable entry.
 - ↳ Avoid moisture in the housing, provide a loop to allow moisture to drain off.
3. Tighten the external locking screw.

Turning the housing

The housing can be rotated up to 380° by loosening the locking screw.

NOTICE

The housing cannot be unscrewed fully.

- ▶ Loosen the external locking screw by a maximum of 1.5 turns. If the screw is unscrewed too much or completely (beyond the screw anchor point), small parts (counter disk) can become loose and fall out.
- ▶ Tighten the securing screw (hexagon socket 4 mm (0.16 in)) with maximum 3.5 Nm (2.58 lbf ft) ± 0.3 Nm (± 0.22 lbf ft).

Closing the housing covers

NOTICE

Thread and housing cover damaged from dirt and fouling!

- ▶ Remove dirt (e.g. sand) on the thread of the covers and housing.
- ▶ If you continue to encounter resistance when closing the cover, check the thread again for fouling.



Housing thread

The threads of the electronics and connection compartment can be coated with an anti-friction coating.

The following applies for all housing materials:

 **Do not lubricate the housing threads.**

Turning the display module

⚠ WARNING

Supply voltage switched on!

Risk of electric shock and/or explosion!

- ▶ Switch off the supply voltage before opening the device.

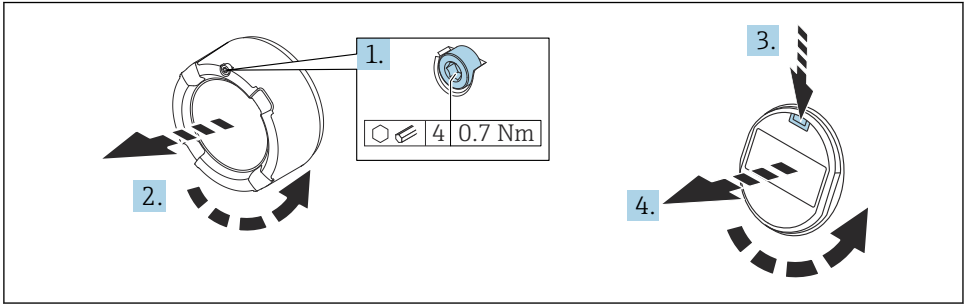

A0038224

1. If fitted: release the screw of the cover lock for the electronics compartment cover using the Allen key.
2. Unscrew the cover from the housing and inspect the cover seal.
3. Press the release mechanism and remove the display module.
4. Turn the display module to the desired position: maximum $4 \times 90^\circ$ in each direction. Insert the display module into the desired position until it clicks into place. Screw the cover tightly back onto the housing. If fitted: tighten the screw of the cover lock using the Allen key 0.7 Nm (0.52 lbf ft) ± 0.2 Nm (± 0.15 lbf ft).



In the case of a dual-compartment housing, the display can be mounted in the electronics compartment as well as in the connection compartment.

6 Electrical connection

6.1 Required tool

- Screwdriver for electrical connection
- Allen key for screw of cover lock

6.2 Connecting requirements

6.2.1 Cover with securing screw

The cover is locked by a securing screw in devices for use in hazardous areas with certain explosion protection.

NOTICE

If the securing screw is not positioned correctly, the cover cannot provide secure sealing.

- ▶ Open the cover: slacken the screw of the cover lock with a maximum of 2 turns so that the screw does not fall out. Fit the cover and check the cover seal.
- ▶ Close the cover: screw the cover securely onto the housing, making sure that the securing screw is positioned correctly. There should not be any gap between the cover and housing.

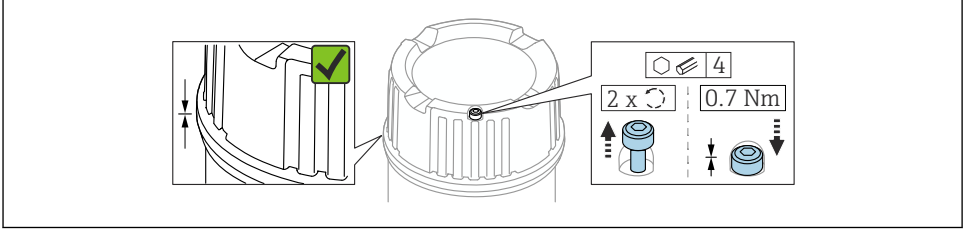

A0039520

14 Cover with securing screw

6.2.2 Potential equalization

⚠ WARNING

Explosion Hazard!

- ▶ Please refer to the separate documentation on applications in hazardous areas for the safety instructions.

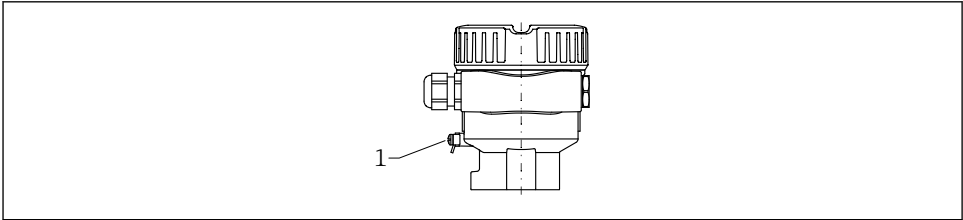

A0045830

1 Ground terminal for connecting the potential matching line

If necessary, the potential matching line can be connected to the external ground terminal of the transmitter before the device is connected.

For optimum electromagnetic compatibility:

- Potential matching line as short as possible
- Observe a cross-section of at least 2.5 mm² (14 AWG)

6.3 Connecting the device

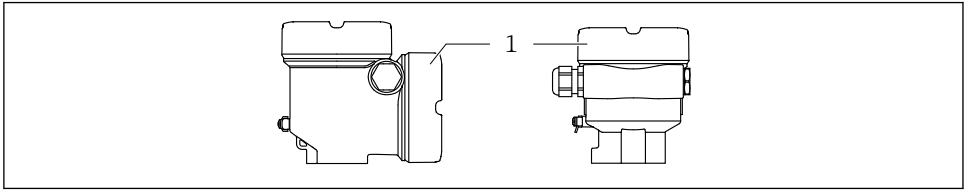

A0046355

1 Connection compartment cover



Housing thread

The threads of the electronics and connection compartment can be coated with an anti-friction coating.

The following applies for all housing materials:

✘ Do not lubricate the housing threads.

6.3.1 Supply voltage

- $U = 10.5$ to $35 V_{DC}$ (Ex d, Ex e, non-Ex)
- $U = 10.5$ to $30 V_{DC}$ (Ex i)
- Rated current: 4 to 20 mA HART



- The power unit must be tested to ensure it meets safety requirements (e.g. PELV, SELV, Class 2) and must comply with the relevant protocol specifications.
- Comply with the following according to IEC/EN61010-1: provide a suitable circuit breaker for the device.

6.3.2 Terminals

- Supply voltage and internal ground terminal: 0.5 to 2.5 mm^2 (20 to 14 AWG)
- External ground terminal: 0.5 to 4 mm^2 (20 to 12 AWG)

6.3.3 Cable specification

- The cable outer diameter depends on the cable entry used
- Cable outer diameter
 - Plastic: $\varnothing 5$ to 10 mm (0.2 to 0.38 in)
 - Nickel-plated brass: $\varnothing 7$ to 10.5 mm (0.28 to 0.41 in)
 - Stainless steel: $\varnothing 7$ to 12 mm (0.28 to 0.47 in)
 - Stainless steel, hygienic: $\varnothing 9$ to 12 mm (0.35 to 0.47 in)

6.3.4 4 to 20 mA HART

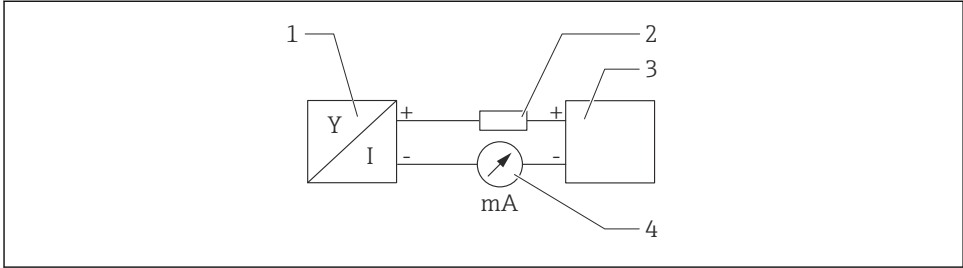

A0028908

15 Block diagram of HART connection

- 1 Device with HART communication
- 2 HART communication resistor
- 3 Power supply
- 4 Multimeter or ammeter

i The HART communication resistor of 250 Ω in the signal line is always necessary in the case of a low-impedance power supply.

Take the voltage drop into consideration:

Maximum 6 V for a 250 Ω communication resistor

6.3.5 Overvoltage protection

Devices without optional overvoltage protection

Equipment from Endress+Hauser fulfills the requirements of the product standard IEC/DIN EN 61326-1 (Table 2 Industrial Environment).

Depending on the type of port (DC supply, input/output port) different test levels according to IEC/DIN EN 61326-1 against transient overvoltages (Surge) are applied (IEC/DIN EN 61000-4-5): Test level on DC power ports and input/output ports is 1 000 V line to earth

Devices with optional overvoltage protection

- Spark-over voltage: min. 400 V_{DC}
- Tested: According to IEC/DIN EN 60079-14 sub chapter 12.3 (IEC/DIN EN 60060-1 chapter 7)
- Nominal discharge current: 10 kA

Overvoltage category

Overvoltage category II

Pollution degree

Pollution degree 2

6.3.6 Wiring

WARNING

Supply voltage might be connected!

Risk of electric shock and/or explosion!

- ▶ If the device is used in hazardous areas, make sure to comply with national standards and the specifications in the Safety Instructions (XAs). The specified cable gland must be used.
- ▶ The supply voltage must match the specifications on the nameplate.
- ▶ Switch off the supply voltage before connecting the device.
- ▶ If necessary, the potential matching line can be connected to the outer ground terminal of the transmitter before the device is connected.
- ▶ A suitable circuit breaker should be provided for the device in accordance with IEC/EN 61010.
- ▶ The cables must be adequately insulated, with due consideration given to the supply voltage and the overvoltage category.
- ▶ The connecting cables must offer adequate temperature stability, with due consideration given to the ambient temperature.
- ▶ Only operate the device with the covers closed.

Connect the device in the following order:

1. Release the cover lock (if provided).
2. Unscrew the cover.
3. Guide the cables into the cable glands or cable entries. Use a suitable tool with width across flats AF24/25 (8 Nm (5.9 lbf ft)) for the M20 cable gland.
4. Connect the cable.
5. Tighten the cable glands or cable entries so that they are leak-tight. Counter-tighten the housing entry.
6. Screw the cover securely back onto the connection compartment.
7. If fitted: tighten the screw of the cover lock using the Allen key 0.7 Nm (0.52 lbf ft) ± 0.2 Nm (0.15 lbf ft).

6.3.7 Terminal assignment

Single-compartment housing

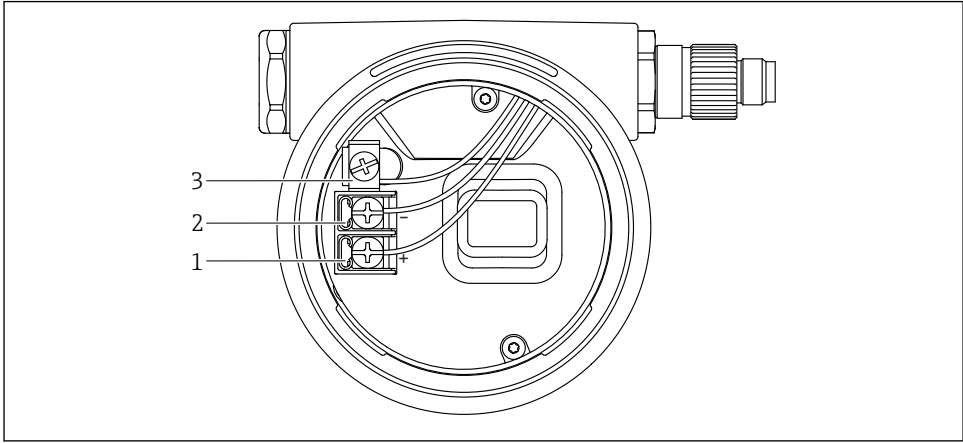

A0042594

16 Connection terminals and ground terminal in the connection compartment

- 1 Positive terminal
- 2 Negative terminal
- 3 Internal ground terminal

Dual-compartment housing, L-form

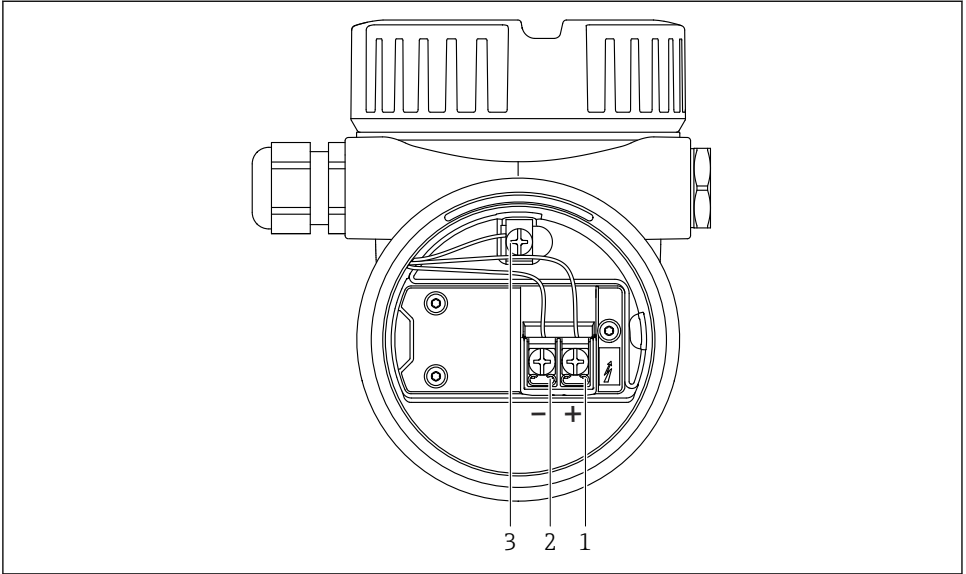

A0045842

▣ 17 Connection terminals and ground terminal in the connection compartment

- 1 Positive terminal
- 2 Negative terminal
- 3 Internal ground terminal

6.3.8 Cable entries

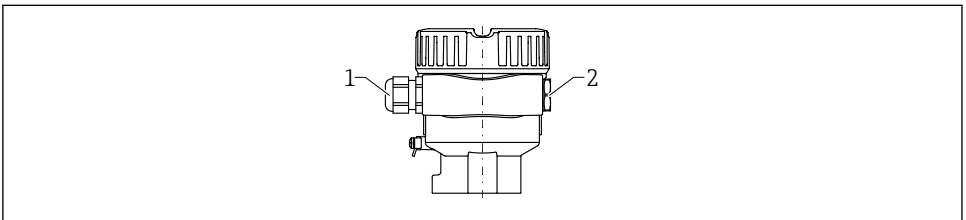

A0045831

- 1 Cable entry
- 2 Dummy plug

The type of cable entry depends on the device version ordered.

6.3.9 Available connectors



In the case of devices with a plug, it is not necessary to open the housing for connection purposes.

M12 plug

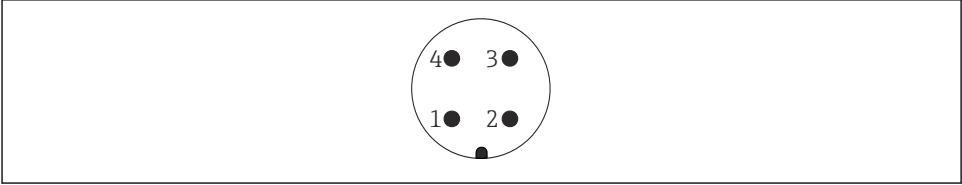

A0011175

18 M12 plug, pin assignment

- 1 Signal +
- 2 Not used
- 3 Signal -
- 4 Ground

 For more details, see the "Accessories" section.

6.4 Ensuring the degree of protection

6.4.1 Degree of protection

Testing according to IEC 60529 and NEMA 250

IP68 test condition: 1.83 m H₂O for 24 h

Housing

See cable entries

Cable entries

- M20 coupling, plastic, IP66/68 NEMA Type 4X/6P
- M20 coupling, nickel-plated brass, IP66/68 NEMA Type 4X/6P
- M20 coupling, 316L, IP66/68 NEMA Type 4X/6P
- M20 coupling, 316L, hygienic, IP66/68/69 NEMA Type 4X/6P
- M20 thread, IP66/68 NEMA Type 4X/6P
- G ½ thread, NPT ½, IP66/68 NEMA Type 4X/6P

Degree of protection for M12 plug

- When housing is closed and connecting cable is plugged in: IP66/67 NEMA Type 4X
- When housing is open or connecting cable is not plugged in: IP20, NEMA Type 1

NOTICE**M12 plug: Loss of IP protection class due to incorrect installation!**

- ▶ The degree of protection only applies if the connecting cable used is plugged in and screwed tight.
- ▶ The degree of protection only applies if the connecting cable used is specified according to IP67 NEMA Type 4X.



If the "M12 plug" option is selected as the electrical connection, **IP66/67 NEMA Type 4X** applies for all housing types.

7 Operation options



For additional information about the connection, see the Operating Instructions for the device. Documentation currently available on the Endress+Hauser- website: www.endress.com → Downloads.

7.1 FEL60H electronic insert

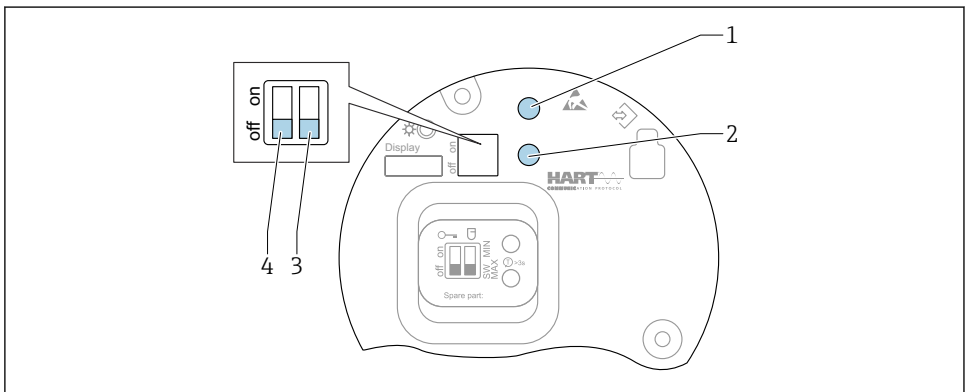

A0046129

19 Operating keys and DIP switch on FEL60H electronic insert

- 1 Operating key for reset password (for Bluetooth login and Maintenanceuser role)
- 1+2 Operating keys for device reset (as-delivered state)
- 2 Operating key for "Proof test" wizard (> 3 s)
- 3 DIP switch for safety function, software-defined (SW, default = MAX) or permanently MIN (in the SW switch position, the MIN or MAX setting is defined by the software. MAX is the default value. In the MIN switch position, the setting is permanently MIN irrespective of the software).
- 4 DIP switch for locking and unlocking the device

- Minimum/maximum quiescent current safety can be switched at the electronic insert
- MAX = maximum safety: when the tuning fork is covered the output switches to demand mode, e.g. use for overflow protection
- MIN = minimum safety: when the tuning fork is uncovered, the output switches to demand mode, e.g. use to prevent pumps from running dry

i The setting of the DIP switches on the electronic insert has priority over the settings made via other operation methods (e.g. FieldCare/DeviceCare).

7.2 Overview of operating options

- Operation via operating keys and DIP switches on the electronic insert
- Operation via optical operating keys on the device display (optional)
- Operation via Bluetooth® wireless technology (with optional device display with Bluetooth) with Smartblue app or FieldXpert, DeviceCare
- Operation via operating tool (Endress+Hauser FieldCare/DeviceCare, handheld terminal, AMS, PDM, ...)

7.3 Access to the operating menu via onsite display

7.3.1 Device display (optional)

Possible to operate the optical operating keys through the cover. No need to open the device.

i Backlighting is switched on or off depending on the supply voltage and the current consumption.

i The device display is also optionally available with Bluetooth® wireless technology.

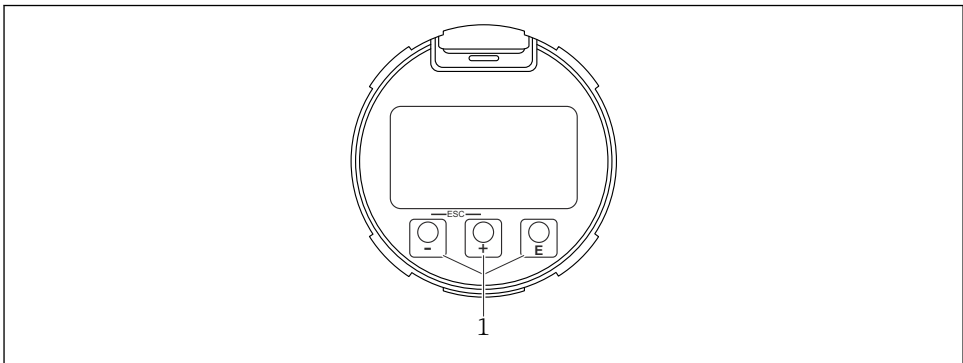

A0039284

20 Graphic display with optical operating keys (1)

7.3.2 Operation via Bluetooth® wireless technology (optional)

Prerequisite

- Device with device display including Bluetooth
- Smartphone or tablet with Endress+Hauser SmartBlue app or PC with DeviceCare from version 1.07.05 or FieldXpert SMT70

The connection has a range of up to 25 m (82 ft). The range can vary depending on environmental conditions such as attachments, walls or ceilings.

 The operating keys on the display are locked as soon as the device is connected via Bluetooth.

A flashing Bluetooth symbol indicates that a Bluetooth connection is available.

Please note the following

If the Bluetooth display is removed from one device and installed in another device:

- All the log-in data are only saved in the Bluetooth display and not in the device
- The password changed by the user is also saved in the Bluetooth display

Operation via SmartBlue App

The device can be operated and configured with the SmartBlue App.

- The SmartBlue App must be downloaded onto a mobile device for this purpose.
- For information on the compatibility of the SmartBlue App with mobile devices, see **Apple App Store (iOS devices)** or **Google Play Store (Android devices)**.
- Incorrect operation by unauthorized persons is prevented by means of encrypted communication and password encryption.
- The Bluetooth® function can be deactivated after initial device setup.

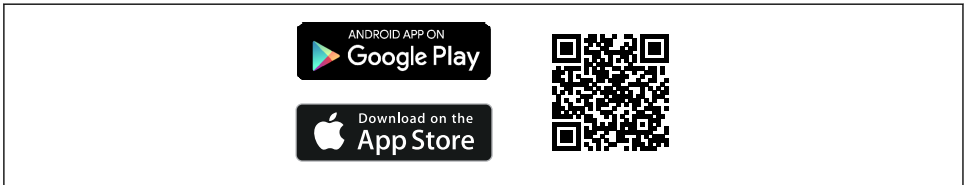

A0033202

 21 QR code for free Endress+Hauser SmartBlue App

Download and installation:

1. Scan the QR code or enter **SmartBlue** in the search field of the Apple App Store (iOS) or Google Play Store (Android).
2. Install and start the SmartBlue App.
3. For Android devices: enable location tracking (GPS) (not required for iOS devices).
4. Select a device that is ready to receive from the device list displayed.

Login:

1. Enter the user name: admin

2. Enter the initial password: serial number of the device

 Change the password after logging in for the first time.

 Forgotten your password? Contact Endress+Hauser Service.

7.4 Access to the operating menu via the operating tool

 For more information, see the Operating Instructions.

8 Commissioning

8.1 Preparations

WARNING

The settings of the current output are relevant for safety!

Incorrect settings may cause the product to overflow or a pump to run dry.

- ▶ The setting for the current output depends on the setting in the **Assign PV** parameter.
- ▶ After changing the setting of the current output: check the settings for the range (Lower range value output (LRV) and Upper range value output (URV)) and reconfigure them if necessary!

8.1.1 As-delivered state

If no customized settings were ordered:

- **Assign PV** parameter Level limit detection (8/16 mA mode)
- MAX safety mode
- Alarm condition set to min. 3.6 mA
- DIP switch for locking in OFF position
- Bluetooth switched on
- Density range $> 0.7 \text{ g/cm}^3$ (43.7 lb/ft^3)
- Switching times 0.5 s when the fork is covered and 1.0 s when it is uncovered
- HART burst mode switched off

8.2 Switching on the device

 All configuration tools provide a commissioning assistant that supports the user when setting the most important configuration parameters (**Guidance** menu **Commissioning** wizard).

8.3 Further information

 Further information and currently available documentation can be found on the Endress+Hauser website: www.endress.com → Downloads.



71658458

www.addresses.endress.com
