

Brief Operating Instructions

iTEMP TMT162

Temperature field transmitter
HART® communication



These Brief Operating Instructions are not a substitute for the Operating Instructions pertaining to the device.

Detailed information can be found in the Operating Instructions and the additional documentation.

Available for all device versions via:

- Internet: www.endress.com/deviceviewer
- Smartphone/tablet: Endress+Hauser Operations app



A0023555

Table of contents

1	About this document	3
1.1	Function of document and how to use	3
1.2	Symbols	4
1.3	Registered trademarks	5
2	Safety instructions	6
2.1	Requirements for the personnel	6
2.2	Intended use	6
2.3	Workplace safety	6
2.4	Operational safety	6
2.5	Product safety	7
3	Incoming acceptance and product identification	7
3.1	Incoming acceptance	7
3.2	Product identification	7
3.3	Certificates and approvals	8
3.4	Storage and transport	8
4	Mounting	8
4.1	Mounting requirements	9
4.2	Mounting the transmitter	9
4.3	Post-mounting check	12
5	Electrical connection	12
5.1	Connecting requirements	12
5.2	Connecting the sensor	13
5.3	Connecting the measuring instrument	15
5.4	Special connection instructions	17
5.5	Ensuring the degree of protection	18
5.6	Post-connection check	18
6	Operation options	19
6.1	Overview of operation options	19
6.2	Access to the operating menu via the operating tool	22
7	Commissioning	22
7.1	Function check	22
7.2	Switching on the device	22
8	Maintenance	23
8.1	Cleaning	23

1 About this document

1.1 Function of document and how to use

1.1.1 Document function

The Brief Operating Instructions contain all the essential information from incoming acceptance to initial commissioning.

1.1.2 Safety Instructions (XA)

The relevant national standards must be observed when using equipment in hazardous areas. Separate Ex-specific documentation is provided for measuring systems that are used in hazardous areas. This documentation is an integral part of these Operating Instructions. The installation specifications, connection data and safety instructions contained therein must be strictly observed! Make sure that you use the right Ex-specific documentation for the right device with approval for use in hazardous areas! The number of the specific Ex documentation (XA...) is provided on the nameplate. If the two numbers (on the Ex documentation and the nameplate) are identical, then you may use this Ex-specific documentation.

1.1.3 Functional safety



Please refer to the Functional Safety Manual (FY01106T) for the use of approved devices in safety-related systems according to IEC 61508.

1.2 Symbols

1.2.1 Safety symbols

⚠ DANGER

This symbol alerts you to a dangerous situation. Failure to avoid this situation will result in serious or fatal injury.

⚠ WARNING

This symbol alerts you to a potentially dangerous situation. Failure to avoid this situation can result in serious or fatal injury.

⚠ CAUTION

This symbol alerts you to a potentially dangerous situation. Failure to avoid this situation can result in minor or medium injury.

NOTICE









This symbol alerts you to a potentially harmful situation. Failure to avoid this situation can result in damage to the product or something in its vicinity.

1.2.2 Electrical symbols



Symbol	Meaning	Symbol	Meaning
	Direct current		Alternating current
	Direct current and alternating current		Ground connection A grounded terminal which, as far as the operator is concerned, is grounded via a grounding system.

Symbol	Meaning
	<p>Potential equalization connection (PE: protective earth) Ground terminals that must be connected to ground prior to establishing any other connections.</p> <p>The ground terminals are located on the interior and exterior of the device:</p> <ul style="list-style-type: none"> ▪ Interior ground terminal: potential equalization is connected to the supply network. ▪ Exterior ground terminal: device is connected to the plant grounding system.

1.2.3 Symbols for certain types of information

Symbol	Meaning	Symbol	Meaning
	<p>Permitted Procedures, processes or actions that are permitted.</p>		<p>Preferred Procedures, processes or actions that are preferred.</p>
	<p>Forbidden Procedures, processes or actions that are forbidden.</p>		<p>Tip Indicates additional information.</p>
	Reference to documentation		Reference to page
	Reference to graphic	1, 2, 3...	Series of steps
	Result of a step		Visual inspection

1.2.4 Symbols in graphics

Symbol	Meaning	Symbol	Meaning
1, 2, 3,...	Item numbers	1, 2, 3...	Series of steps
A, B, C, ...	Views	A-A, B-B, C-C, ...	Sections
	Hazardous area		Safe area (non-hazardous area)

1.3 Registered trademarks

HART®

Registered trademark of the FieldComm Group, Austin, Texas, USA

2 Safety instructions

2.1 Requirements for the personnel

The operating personnel must fulfill the following requirements:

- ▶ Trained, qualified specialists: must have a relevant qualification for this specific function and task
- ▶ Are authorized by the plant owner/operator
- ▶ Are familiar with federal/national regulations
- ▶ Before beginning work, the specialist staff must have read and understood the instructions in the manuals and supplementary documentation as well as in the certificates (depending on the application)
- ▶ Follow instructions and comply with basic conditions

2.2 Intended use

The device is a universal and configurable temperature field transmitter with either one or two temperature sensor inputs for resistance thermometers (RTD), thermocouples (TC) and resistance and voltage transmitters. The device is designed for mounting in the field.

The manufacturer is not liable for damage caused by improper or non-intended use.

2.3 Workplace safety

When working on and with the device:

- ▶ Wear the required personal protective equipment as per national regulations.

2.4 Operational safety

- Operate the device only if it is in proper technical condition, free from errors and faults.
- The operator is responsible for the interference-free operation of the device.

Power supply

- ▶ The device must only be powered by a 11.5 to 42 V_{DC} voltage supply according to NEC class 02 (low voltage/current) with short circuit power limitation to 8 A/150 VA.

Hazardous area

To eliminate a danger for persons or for the facility when the device is used in the hazardous area (e.g. explosion protection or safety equipment):

- ▶ Based on the technical data on the nameplate, check whether the ordered device is permitted for the intended use in the hazardous area. The nameplate can be found on the side of the transmitter housing.
- ▶ Observe the specifications in the separate supplementary documentation included as an integral part of these instructions.

Electromagnetic compatibility

The measuring system complies with the general safety requirements as per EN 61010-1, the EMC requirements as per the IEC/EN 61326 series and the NAMUR recommendations NE 21 and NE 89.

2.5 Product safety

This measuring device is designed in accordance with good engineering practice to meet state-of-the-art safety requirements, has been tested, and left the factory in a condition in which it is safe to operate.

It meets general safety standards and legal requirements. It also complies with the EU directives listed in the device-specific EU Declaration of Conformity. The manufacturer confirms this by affixing the CE mark to the device.

3 Incoming acceptance and product identification

3.1 Incoming acceptance

On receipt of the delivery:

1. Check the packaging for damage.
 - ↳ Report all damage immediately to the manufacturer.
Do not install damaged components.
2. Check the scope of delivery using the delivery note.
3. Compare the data on the nameplate with the order specifications on the delivery note.
4. Check the technical documentation and all other necessary documents, e.g. certificates, to ensure they are complete.



If one of the conditions is not satisfied, contact the manufacturer.

3.2 Product identification

The device can be identified in the following ways:

- Nameplate specifications
- Enter the serial number from the nameplate in the *Device Viewer* (www.endress.com/deviceviewer): All data relating to the device and an overview of the Technical Documentation supplied with the device are displayed.
- Enter the serial number on the nameplate into the *Endress+Hauser Operations App* or scan the 2-D matrix code (QR code) on the nameplate with the *Endress+Hauser Operations App*: all the information about the device and the technical documentation pertaining to the device is displayed.

3.2.1 Nameplate

Do you have the correct device?

The nameplate provides you with the following information on the device:

- Manufacturer identification, device designation
- Order code
- Extended order code
- Serial number

- Tag name (TAG) (optional)
 - Technical values, e.g. supply voltage, current consumption, ambient temperature, communication-specific data (optional)
 - Degree of protection
 - Approvals with symbols
 - Reference to Safety Instructions (XA) (optional)
- Compare the information on the nameplate with the order.

3.2.2 Name and address of manufacturer

Name of manufacturer:	Endress+Hauser Wetzler GmbH + Co. KG
Address of manufacturer:	Obere Wank 1, D-87484 Nesselwang or www.endress.com

3.3 Certificates and approvals

 For certificates and approvals valid for the device: see the data on the nameplate

 Approval-related data and documents: www.endress.com/deviceviewer → (enter the serial number)

3.4 Storage and transport

Storage temperature	Without display -40 to +100 °C (-40 to +212 °F)
	With display -40 to +80 °C (-40 to +176 °F)

Maximum relative humidity: < 95 % as per IEC 60068-2-30

 Pack the device for storage and transportation in such a way that it is reliably protected against impact and external influences. The original packaging provides optimum protection.

Avoid the following environmental influences during storage:

- Direct sunlight
- Proximity to hot objects
- Mechanical vibration
- Aggressive media

4 Mounting



If stable sensors are used, the device can be fitted directly to the sensor. For remote mounting to a wall or stand pipe, two mounting brackets are available. The backlit display can be mounted in four different positions.

4.1 Mounting requirements

4.1.1 Installation point

For use in hazardous areas, the limit values specified on the certificates and approvals must be observed (see XA Safety Instructions).

4.1.2 Important ambient conditions

Ambient temperature range	<ul style="list-style-type: none"> ▪ Without display: -40 to +85 °C (-40 to +185 °F) ▪ With display: -40 to +80 °C (-40 to +176 °F) <p>For use in hazardous areas, please see the Ex certificate, which is an integral part of the product documentation.</p> <p> The display may react slowly at temperatures < -20 °C (-4 °F). The legibility of the display cannot be guaranteed at temperatures < -30 °C (-22 °F).</p>
Altitude	Up to 2 000 m (6 560 ft) above mean sea level
Overvoltage category	II
Pollution degree	2
Insulation class	Class III
Condensation	Permitted
Climate class	As per IEC 60654-1, Class C
Degree of protection	Die-cast aluminum or stainless steel housing; IP67, NEMA 4X
Shock and vibration resistance	<p>Shock resistance as per KTA 3305 (section 5.8.4 Shock test)</p> <ul style="list-style-type: none"> ▪ IEC 60068-2-6 test ▪ Fc: Vibration (sinusoidal) <p>Vibration resistance: Vibration resistance as per DNVGL-CG-0339 : 2021 and DIN EN 60068-2-6:</p> <ul style="list-style-type: none"> ▪ 25 to 100 Hz at 4g ▪ 5 to 25 Hz, 1.6 mm <p> The use of L-shaped mounting brackets can cause resonance (see wall/ pipe 2" mounting bracket in the 'Accessories' section). Caution: vibrations occurring directly at the transmitter may not exceed specifications.</p>

4.2 Mounting the transmitter

NOTICE

Do not over-tighten the mounting screws, as this could damage the field transmitter.

- ▶ Maximum torque = 6 Nm (4.43 lbf ft)

4.2.1 Direct sensor mounting

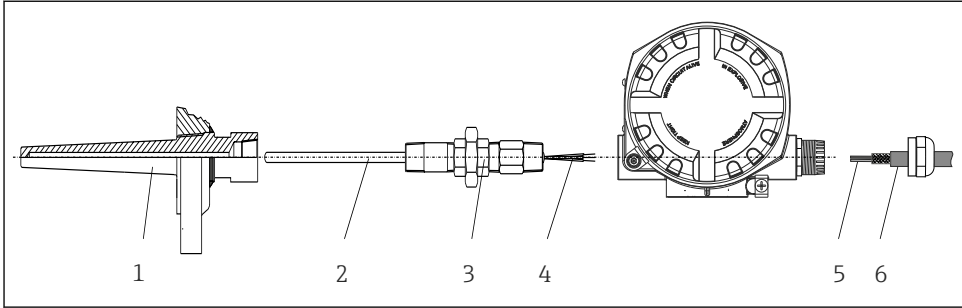

A0024817

1 Direct field transmitter mounting on sensor

- 1 Thermowell
- 2 Insert
- 3 Neck tube nipple and adapter
- 4 Sensor cables
- 5 Fieldbus cables
- 6 Fieldbus shielded cable

1. Mount the thermowell and screw down (1).
2. Screw the insert with the neck tube nipple and adapter into the transmitter (2). Seal the nipple and adapter thread with silicone tape.
3. Connect the sensor cables (4) to the terminals for the sensors, see the terminal assignment.
4. Fit the field transmitter with the insert on the thermowell (1).
5. Mount the fieldbus shielded cable or fieldbus connector (6) on the other cable gland.
6. Guide the fieldbus cables (5) through the cable gland of the fieldbus transmitter housing into the connection compartment.
7. Screw the cable gland tight as described in the *Ensuring the degree of protection* section → 18. The cable gland must meet explosion protection requirements.

4.2.2 Remote mounting

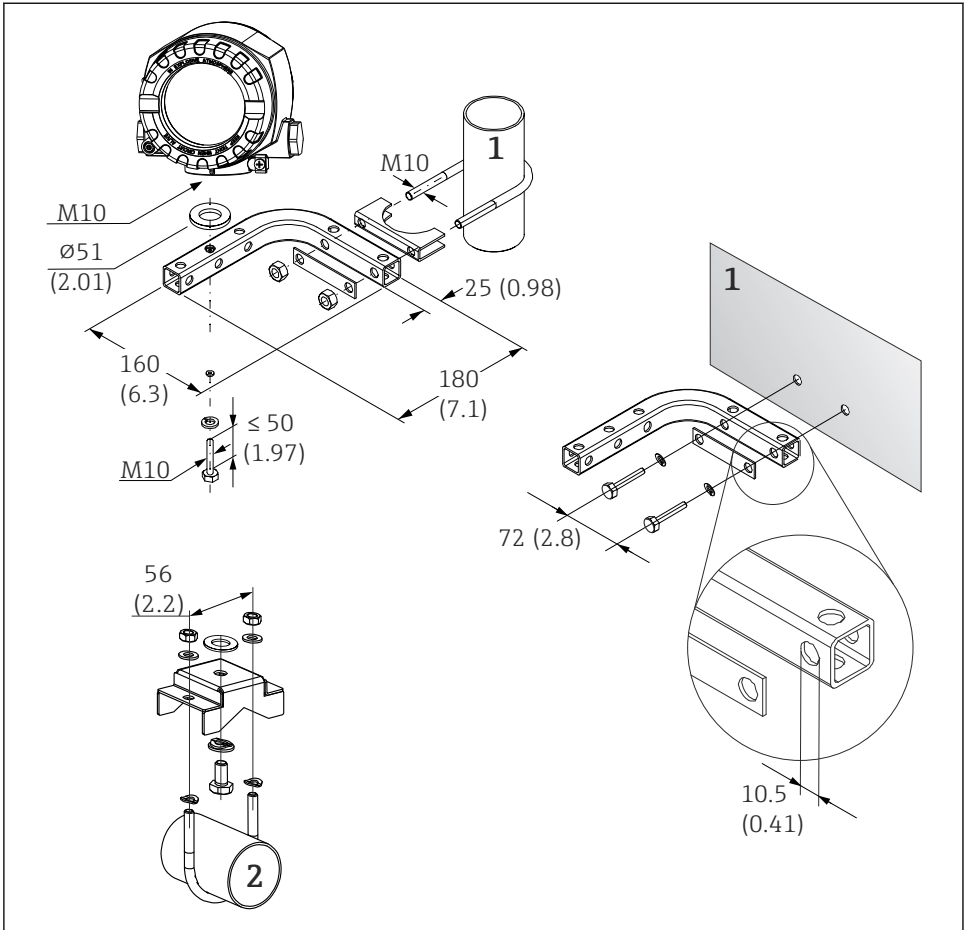

A0027188

2 Installation of the field transmitter using the mounting bracket. Dimensions in mm (in)

- 1 Combined wall/pipe mounting bracket 2", L-shaped, material 304
- 2 Pipe mounting bracket 2", U-shaped, material 316L

4.3 Post-mounting check

After installing the device, perform the following checks:

Device condition and specifications	Notes
Is the device undamaged (visual inspection)?	-
Do the ambient conditions match the device specification (e.g. ambient temperature, degree of protection, etc.)?	→  9

5 Electrical connection

5.1 Connecting requirements

CAUTION

The electronics could be destroyed

- ▶ Switch off power supply before installing or connecting the device. Failure to observe this may result in the destruction of parts of the electronics.
- ▶ When connecting Ex-certified devices, please take special note of the instructions and connection schematics in the Ex-specific supplement to these Operating Instructions. Contact the supplier if you have any questions.





A Phillips head screwdriver is required to wire the field transmitter at the terminals.

NOTICE

Do not over-tighten the screw terminals, as this could damage the transmitter.

- ▶ Maximum torque = 1 Nm ($\frac{3}{4}$ lbf ft).

Proceed as follows to wire the device:

1. Remove the cover clamp.
2. Unscrew the housing cover on the connection compartment together with the O-ring . The connection compartment is opposite the electronics module.
3. Open the cable glands of the device.
4. Route the appropriate connecting cables through the openings of the cable glands.
5. Wire the cables in accordance with →  3,  13 and as described in the sections: "Connecting the sensor" →  13 and "Connecting the measuring instrument" →  15.
6. On completion of the wiring, screw the screw terminals tight. Tighten the cable glands again. Refer to the information provided in the 'Ensuring the degree of protection' section.
7. Clean the thread in the housing cover and housing base and lubricate if necessary. (Recommended lubricant: Klüber Syntheso Glep 1)
8. Screw the housing cover tight again and fit the cover clamp back on.

In order to avoid connection errors always follow the instructions in the post-connection check section before commissioning!

5.2 Connecting the sensor

NOTICE

- ▶  ESD - Electrostatic discharge Protect the terminals from electrostatic discharge. Failure to observe this may result in the destruction or malfunction of parts of the electronics.

Terminal assignment

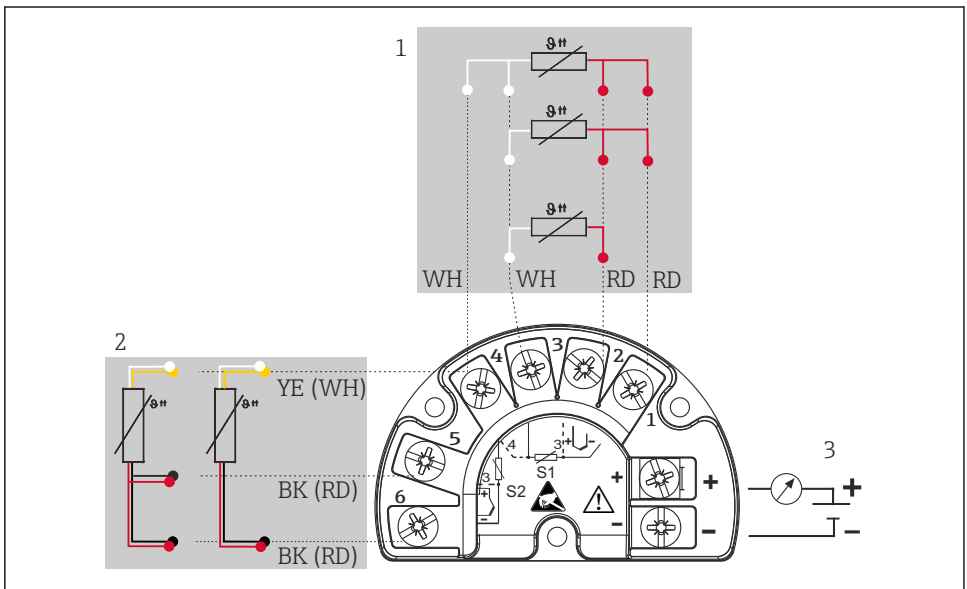

A0045944

3 Wiring of the field transmitter, RTD, dual sensor input

- 1 Sensor input 1, RTD, : 2-, 3- and 4-wire
- 2 Sensor input 2, RTD: 2-, 3-wire
- 3 Field transmitter power supply and analog output 4 to 20 mA or fieldbus connection

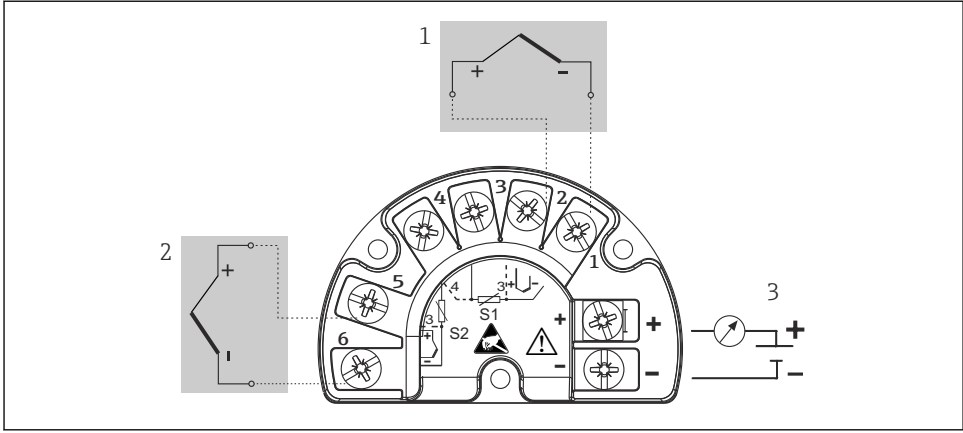

A0045949

4 Wiring of the field transmitter, TC, dual sensor input

- 1 Sensor input 1, TC
- 2 Sensor input 2, TC
- 3 Field transmitter power supply and analog output 4 to 20 mA or fieldbus connection

NOTICE

When connecting 2 sensors ensure that there is no galvanic connection between the sensors (e.g. caused by sensor elements that are not isolated from the thermowell). The resulting equalizing currents distort the measurements considerably.

- The sensors must remain galvanically isolated from one another by connecting each sensor separately to a transmitter. The transmitter provides sufficient galvanic isolation (> 2 kV AC) between the input and output.

The following connection combinations are possible when both sensor inputs are assigned:

		Sensor input 1			
		RTD or resistance transmitter, 2-wire	RTD or resistance transmitter, 3-wire	RTD or resistance transmitter, 4-wire	Thermocouple (TC), voltage transmitter
Sensor input 2	RTD or resistance transmitter, 2-wire	☑	☑	-	☑
	RTD or resistance transmitter, 3-wire	☑	☑	-	☑
	RTD or resistance transmitter, 4-wire	-	-	-	-
	Thermocouple (TC), voltage transmitter	☑	☑	☑	☑

5.3 Connecting the measuring instrument

5.3.1 Cable gland or cable entry

CAUTION

Risk of damage

- ▶ Switch off power supply before installing or connecting the device. Failure to observe this may result in the destruction of parts of the electronics.
- ▶ If the device has not been grounded as a result of the housing being installed, we recommended grounding it via one of the ground screws. Observe the grounding concept of the plant! Keep the cable shield between the stripped fieldbus cable and the ground terminal as short as possible! Connection of the functional grounding may be needed for functional purposes. Compliance with the electrical codes of individual countries is mandatory.
- ▶ In systems without additional potential equalization, grounding the shield of the fieldbus cable at more than one point can lead to the occurrence of mains frequency equalizing currents, potentially causing damage to the cable or its shield. In such cases, the shield of the fieldbus cable should be grounded on one side only, i.e. it must not be connected to the ground terminal of the housing. The shield that is not connected should be insulated!



- The terminals for the fieldbus connection are equipped with integrated reverse polarity protection.
- Cable cross-section: max. 2.5 mm²
- A shielded cable must be used for the connection.

Follow the general procedure. → 12.

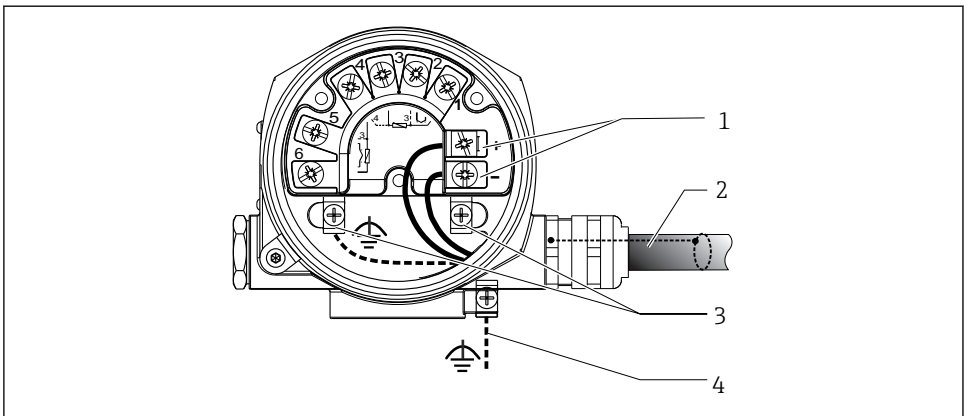

A0010823

5 Connecting the device to the fieldbus cable

- 1 Fieldbus terminals - fieldbus communication and power supply
- 2 Shielded fieldbus cable
- 3 Ground terminals, internal
- 4 Ground terminal (external, relevant for remote version)

5.3.2 Connecting HART communication resistor

i If the HART® communication resistor is not integrated into the power supply unit, it is necessary to incorporate a communication resistor of $250\ \Omega$ into the 2-wire cable. For the connection, also refer to the documentation published by the FieldComm Group, particularly HCF LIT 20: "HART, a technical summary".

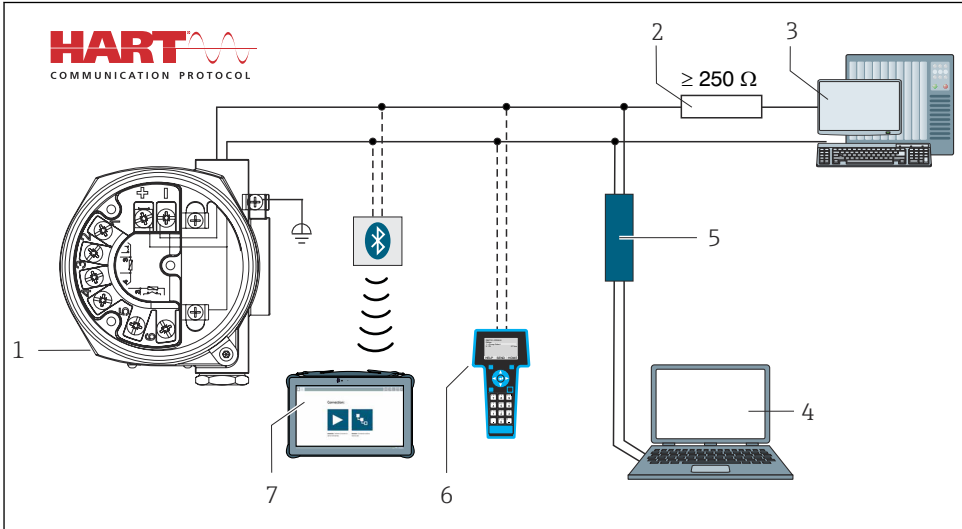

A003549

6 HART connection with other power supply units that do not have a built-in HART communication resistor

- 1 Temperature field transmitter
- 2 HART communication resistor
- 3 PLC/process control system
- 4 Configuration software, e.g. FieldCare, DeviceCare
- 5 HART Modem
- 6 HART handheld communicator
- 7 Configuration via Field Xpert SMT70

5.3.3 Shielding and grounding

The specifications of the FieldComm Group must be observed during installation.

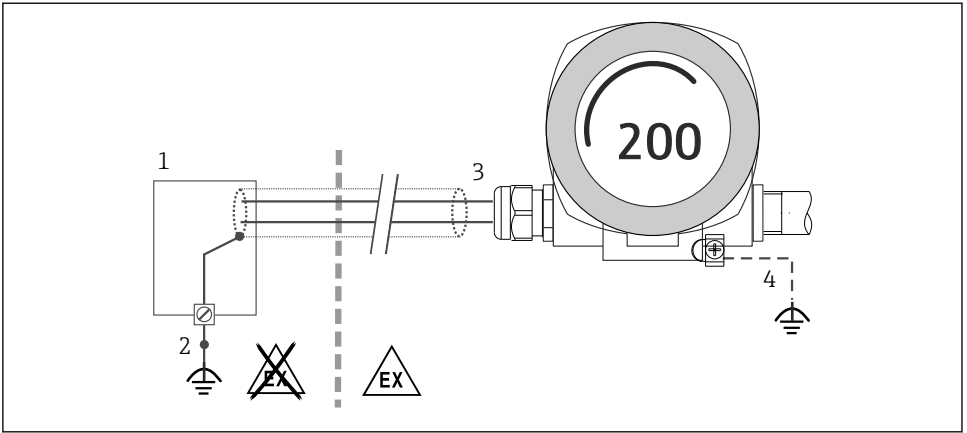

A0010984

7 Shielding and grounding the signal cable at one end with HART communication

- 1 Supply unit
- 2 Grounding point for HART communication cable shield
- 3 Grounding of the cable shield at one end
- 4 Optional grounding of the field device, isolated from cable shielding

5.4 Special connection instructions

If the device is fitted with a surge arrester module, the bus is connected and the power is supplied via the screw terminals on the surge arrester module.

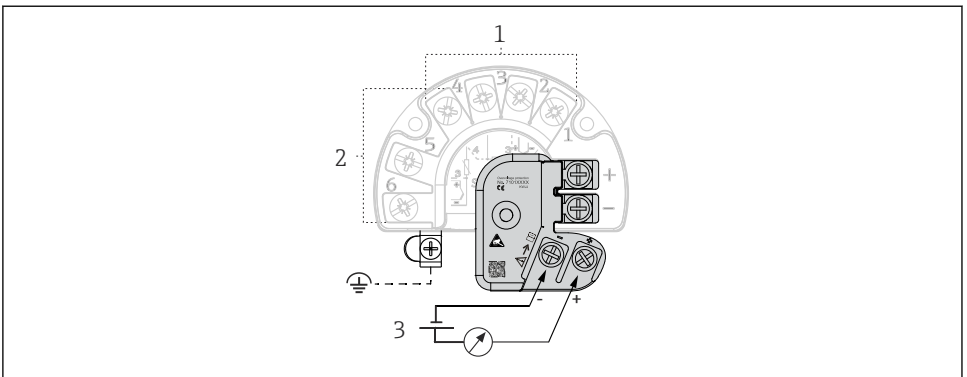





A0045614

8 Electrical connection of surge arrester

- 1 Sensor 1
- 2 Sensor 2
- 3 Bus connector and power supply

5.5 Ensuring the degree of protection

The device meets all the requirements of IP66/IP67 protection. Compliance with the following points is mandatory following installation in the field or servicing in order to ensure that IP66/IP67 protection is maintained:



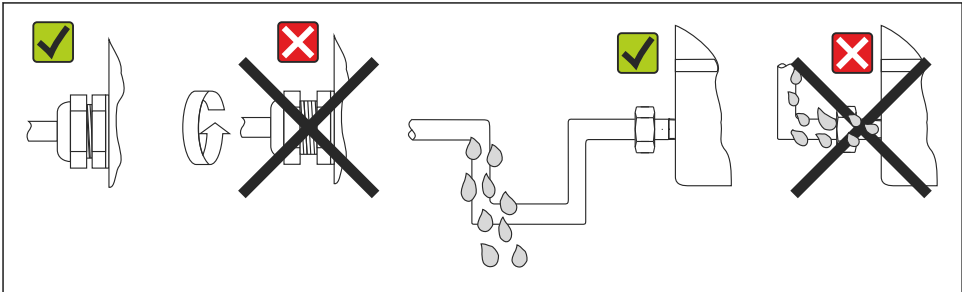

- The housing seals must be clean and undamaged when inserted into their grooves. The seals must be dried, cleaned or replaced if necessary.
- All housing screws and screw caps must be firmly tightened.
- The connecting cables used must have the specified external diameter (e.g. M20x1.5, cable diameter 8 to 12 mm).
- Firmly tighten the cable gland. →  9,  18
- The cables must loop down before they enter the cable glands ("water trap"). This means that any moisture that may form cannot enter the gland. Install the device so that the cable glands are not facing upwards. →  9,  18
- Replace unused cable glands with dummy plugs.
- Do not remove the grommet from the cable gland.



A0024523

 9 Connection tips to retain IP66/IP67 protection

5.6 Post-connection check

Device condition and specifications	Notes
Are the device and cables undamaged (visual check)?	--
Electrical connection	Notes
Does the supply voltage match the information on the nameplate?	Standard mode and SIL mode: $U = 11.5$ to $42 V_{DC}$
Are the mounted cables strain-relieved?	Visual inspection
Are the power supply and signal cables connected correctly?	→  15
Are all the screw terminals sufficiently tightened?	→  12
Are all the cable entries installed, tightened and leak-tight?	→  18
Are all housing covers installed and securely tightened?	→  19

6 Operation options

6.1 Overview of operation options

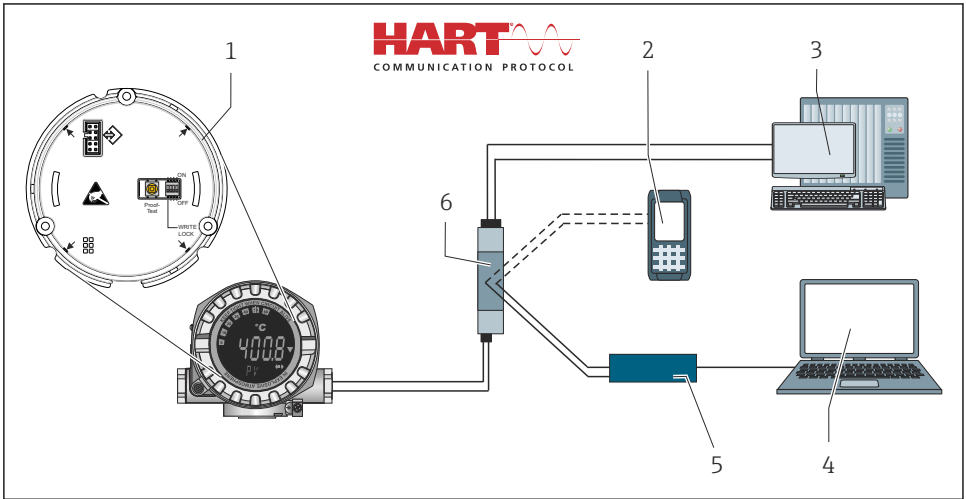

A0024548

10 Operation options of the device

- 1 Hardware settings via DIP switch and proof-test button
- 2 HART handheld communicator
- 3 PLC/process control system
- 4 Configuration software, e.g. FieldCare, DeviceCare
- 5 HART Modem
- 6 Configuration via Field Xpert SMT70
- 7 Power supply unit and active barrier, e.g. RN22 from Endress+Hauser

6.1.1 Measured value display and operating elements

Display elements

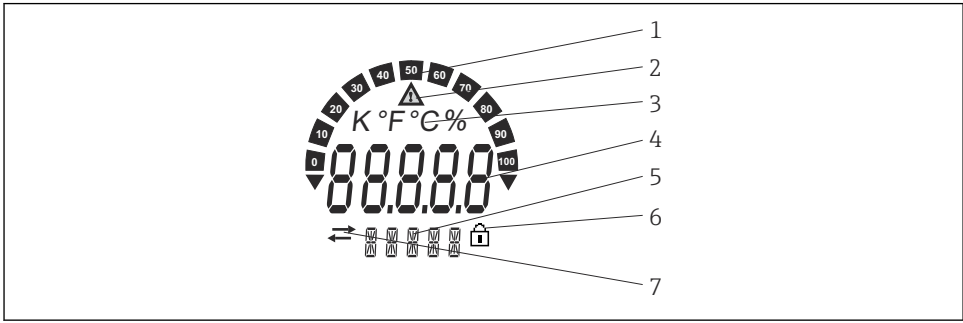

A0034101

11 LC display of the field transmitter (backlit, attachable in 90° increments)

Item no.	Function	Description
1	Bar graph display	In increments of 10% with indicators for underranging and overranging.
2	'Caution' symbol	This is displayed when an error or warning occurs.
3	Unit display K, °F, °C or %	Unit display for the internal measured value shown.
4	Measured value display, digit height 20.5 mm	Displays the current measured value. In the event of an error or warning, the corresponding diagnostics information is displayed. Please refer to the relevant Operating Instructions for the device for more information.
5	Status and information display	Indicates which value is currently shown on the display. Text can be entered for every value. In the event of an error or a warning, the sensor input that triggered the error/warning is also displayed where applicable, e.g. SENS1
6	'Configuration locked' symbol	The 'configuration locked' symbol appears when configuration is locked via the hardware or software
7	'Communication' symbol	The communication symbol appears when HART communication is active.

Local operation

NOTICE

- ▶ ESD - Electrostatic discharge Protect the terminals from electrostatic discharge. Failure to observe this may result in the destruction or malfunction of parts of the electronics.

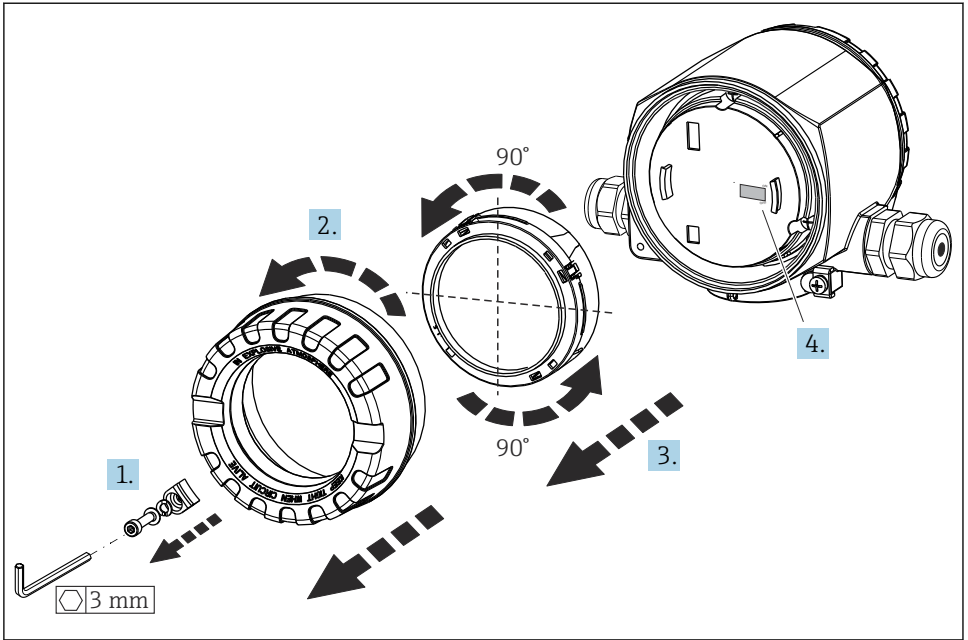

A0011211

Procedure for setting the DIP switch or activating the proof test:

1. Remove the cover clamp.
2. Unscrew the housing cover together with the O-ring.
3. If necessary, remove the display with retainer from the electronics module.
4. Configure the hardware write protection **WRITE LOCK** accordingly using the DIP switch. In general, the following applies: switch to ON = function enabled, switch to OFF = function disabled. If performing a SIL commissioning test and a proof test, make a device restart using the button.

Once the hardware setting has been made, re-assemble the housing cover in the reverse order.

6.2 Access to the operating menu via the operating tool

The transmitter and measured value display are configured via the HART protocol or CDI (= Endress+Hauser Common Data Interface). The following operating tools are available for this purpose:

Operating tools

FieldCare, DeviceCare, Field Xpert (Endress+Hauser)	SIMATIC PDM (Siemens)
AMS Device Manager (Emerson Process Management)	AMS Trex Device Communicator (Emerson Process Management)

 The configuration of device-specific parameters is described in detail in the Operating Instructions for the device.

7 Commissioning

7.1 Function check

Before commissioning the measuring point, make sure that all final checks have been carried out:

- "Post-mounting check" checklist
- "Post-connection check" checklist

7.2 Switching on the device

Once you have completed the post-connection checks, switch on the supply voltage. The transmitter performs a number of internal test functions after power-up. During this process, a sequence containing device information appears on the display.

Step	Indication
1	Text "Display" and firmware version of the display
2	Firm logo
3	Device name (scrolling text)
4	Firmware, hardware revision, device revision and device address
5	For devices in SIL mode: SIL-CRC is displayed
6a	Current measured value or
6b	Current status message  If the switch-on procedure is not successful, the relevant diagnostic event is displayed, depending on the cause. A detailed list of diagnostic events and the corresponding troubleshooting instructions can be found in the Operating Instructions.

The device works after approx. 30 seconds! Normal measuring mode commences as soon as the switch-on procedure is completed. Measured values and status values appear on the display.

8 Maintenance

No special maintenance work is required for the temperature transmitter.

8.1 Cleaning

A clean, dry cloth can be used to clean the device.



71655862

www.addresses.endress.com
