

Technical Information

Cleanfit CPA871

Flexible retractable process assembly for water, wastewater, chemical industry and heavy industry



Application

Cleanfit CPA871 is a flexible process retractable assembly for applications with standard 12 mm sensors for pH and redox.

The assembly was developed to guarantee maximum safety in:

- Water and wastewater including sea water
- Chemical industry
- Oil and gas
- Electricity and energy
- Hazardous areas
- Primaries and metals

Your benefits

- Maximum operational safety: Intelligent functions ensure that the assembly is not inserted into the process without the sensor or unintentionally retracted from the process if the assembly is in measuring position.
- Suitable for demanding applications: The optional immersion chamber eliminates problems associated with media that form buildup.
- Robust assembly design: The metallic support housing ensures that the service chamber is mechanically stable.
- Flexible in adapting to your process: A wide range of process connections and materials in contact with the medium; for corrosive media and hazardous areas also.

Function and system design

Function

With the Cleanfit CPA871 retractable assembly, you can carry out pH, ORP and other measurements reliably using suitable sensors. You can remove, clean, sterilize or calibrate/adjust the sensors without interrupting the process.

The assembly can be installed in both vessels and pipes.

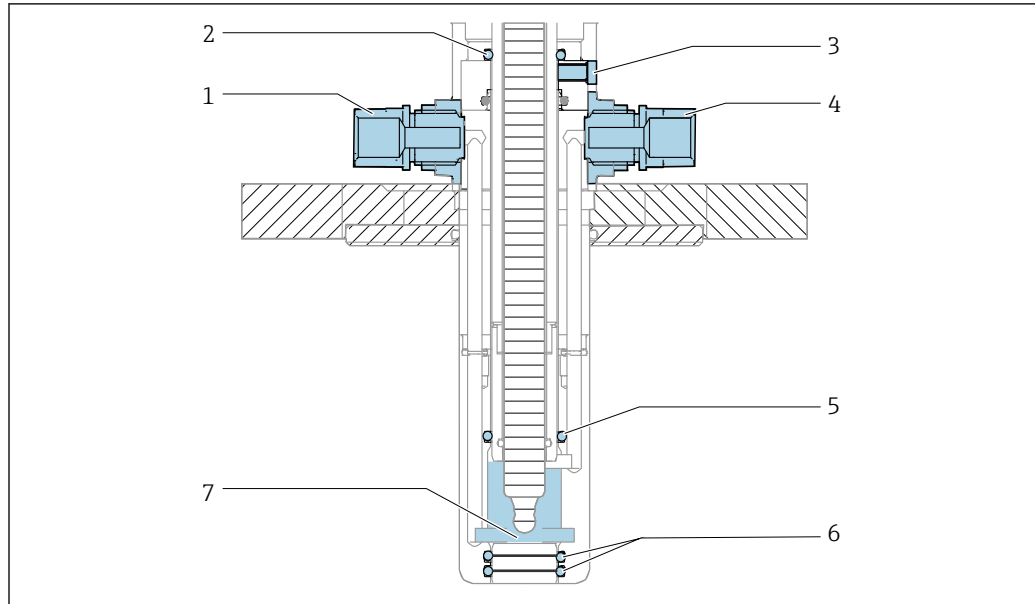

A0039361

1 Sealing system, assembly in service position

- 1 Rinse chamber, inlet
- 2 Seal, drive (1 x O-ring)
- 3 Leakage hole
- 4 Rinse chamber, outlet
- 5 Seal, rinse chamber (1 x O-ring)
- 6 Process seal (2 x O-ring)
- 7 Rinse chamber

The assembly is open to the process during insertion/retraction; the rinse connections must either be pipe-fitted or sealed.

The assembly has a pin seal. This seals the assembly from the process in the relevant limit position.

Process seal

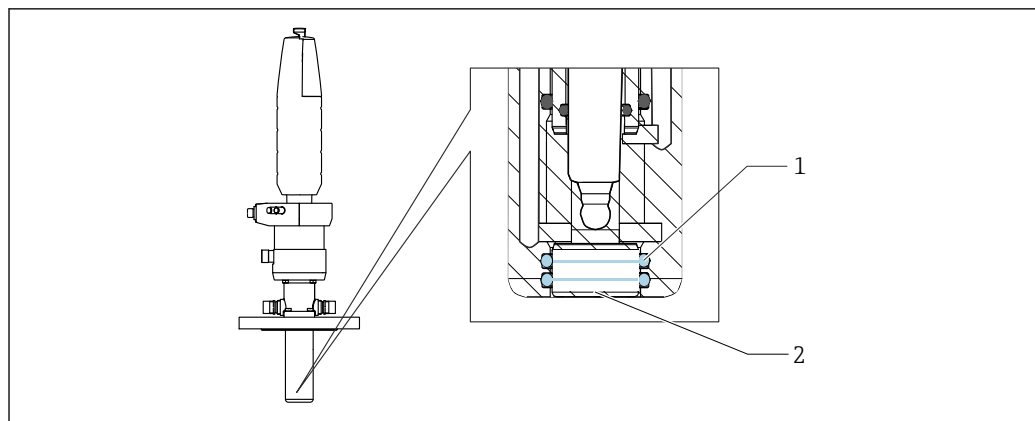

A0039106

2 Process seal, assembly in service position

- 1 Process seal (2 x O-ring)
- 2 Pin

Design

The retractable assembly has a modular design and can therefore be flexibly adapted to a wide array of applications. It is available with both a manual and a pneumatic drive.

A choice of two chamber systems is available for the assembly:

- Standard version or
- Immersion chamber version

It is possible to choose between the following strokes for the electrode guide:

- 36 mm for standard version and immersion chamber version
- 78 mm for standard version

All common process connections are available:

Clamp/flange EN1092-1/flange ASME B16.5/flange JIS B2220/dairy fitting/thread

Safety function**Locking mechanism without sensor**

If the sensor is not installed, it is not possible to pneumatically or manually move the assembly from the service position to the measuring position.

Manual or pneumatic drive

The sensor can be driven both manually and pneumatically. The manual drive has a self-retaining thread to hold the sensor in any intermediate position. The manual drive can be used for process pressures up to 8 bar (116 psi). The pneumatic drive can be used for process pressures up to 16 bar (232 psi).

Limit position locking if compressed air fails

If the compressed air fails in pneumatic assemblies, the assembly remains in the position previously selected. The process pressure cannot force it out of the measuring position and into an intermediate position.

Limit position locking with manual drive

For position locking, the manual version has an unlocking button in both the measuring position and the service position.

Impossible to remove sensor in the measuring position

The protection cap for covering the sensor has the following functions:

- Mechanical sensor safety
- Prevents sensor removal in the assembly measuring position

The bottom part of the protection cap is partly inserted into the drive and cannot be opened as a result.

Non-rotating sensor guide

During insertion/retraction, the position of the ridges of the immersion tube in the area of the sensor head retains the pre-setting once selected. This guarantees optimum and clear positioning of the sensor in the process and during cleaning.

Limit position detection (can be retrofitted)

In the case of assemblies with a pneumatic drive, the service and measuring position of the sensor are detected inductively and reported to connected systems (only for the measuring position in the case of the manual drive assembly).

Elements

The assembly is available with a manual or pneumatic drive.

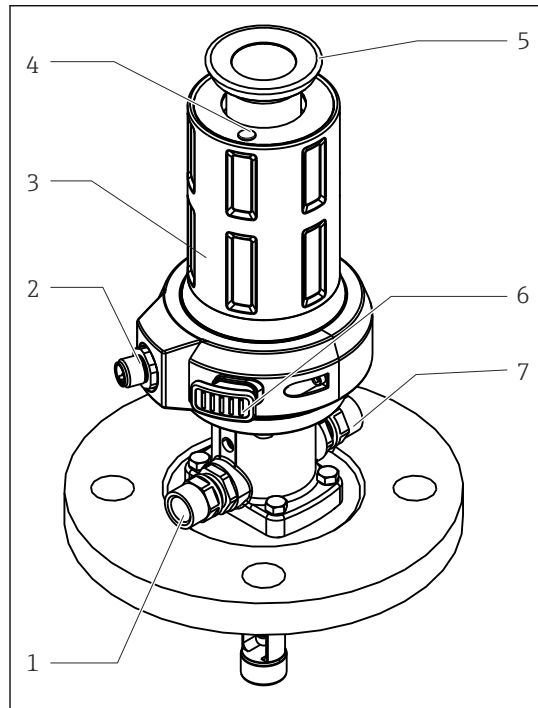

A0029812

3 Assembly with manual drive (without protection cap)

- 1 Rinse connection
- 2 Connection for limit position switch
- 3 Manual drive (fulcrum shaft)
- 4 Unlocking button (service position)
- 5 Fastening ring for protective cap
- 6 Unlocking button (measuring position)
- 7 Rinse connection

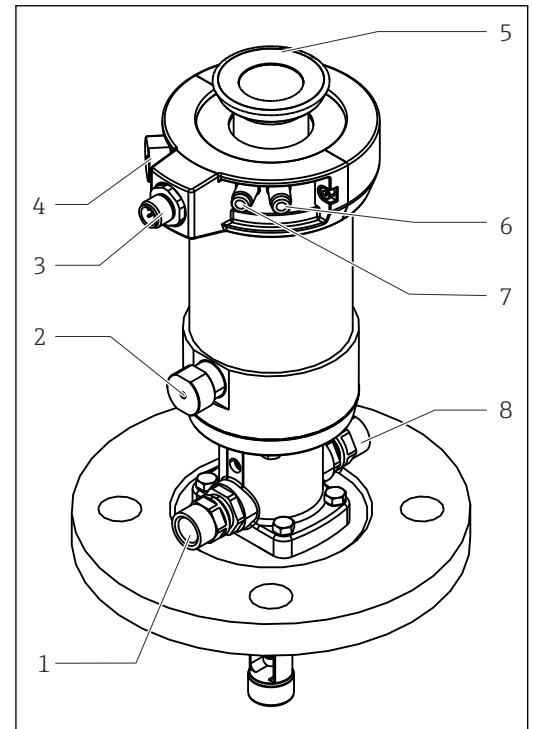

A0023912

4 Assembly with pneumatic drive (without protective cap)

- 1 Rinse connection
- 2 Automatic limit position lock, process
- 3 Connection for limit position switch
- 4 Automatic limit position lock, service
- 5 Fastening ring for protective cap
- 6 Pneumatic connection (move to measuring position)
- 7 Pneumatic connection (move to service position)
- 8 Rinse connection

Measuring system

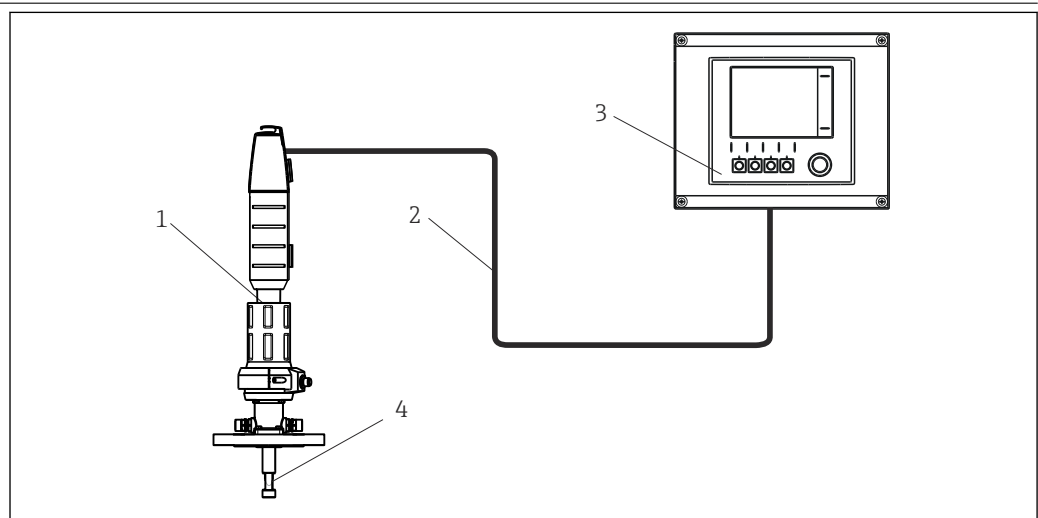

A0029620

5 Measuring system (example)

- 1 Cleanfit assembly CPA871
- 2 Measuring cable
- 3 Liquiline CM44x transmitter
- 4 Sensor

Immersion chamber

The special immersion chamber version is the perfect solution when the sensor descends to greater immersion depths in media that cause buildup and media with a tendency to form condensation. In the process medium, the sensor guide containing the installed sensor is almost completely surrounded by the service chamber. This means that there is minimal contact with the medium. The seals are thus protected from damage when the sensor is moving from measuring to service position.

Assignment of rinse connections

The inlet and outlet of the service chamber are fixed. The outlet of the service chamber is located under the leakage borehole. The leakage hole is sealed with an M5 screw.

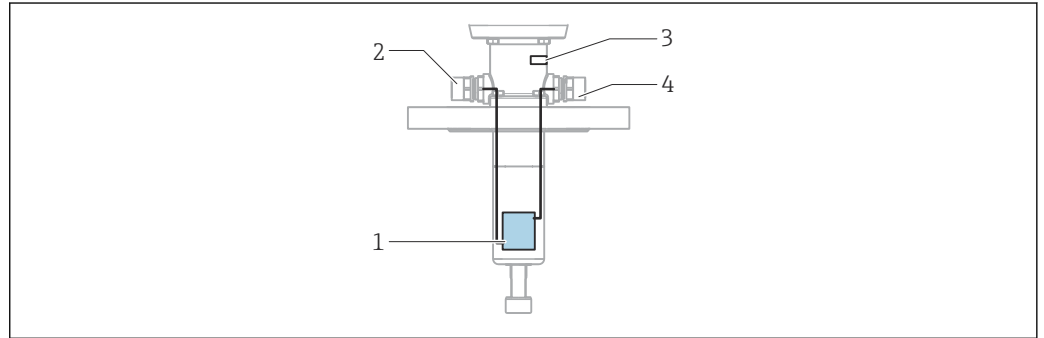

A0028521

 6 Connection of service chamber in the immersion chamber version

- 1 Service chamber
- 2 Service chamber inlet
- 3 Leakage hole
- 4 Service chamber outlet

Service chamber

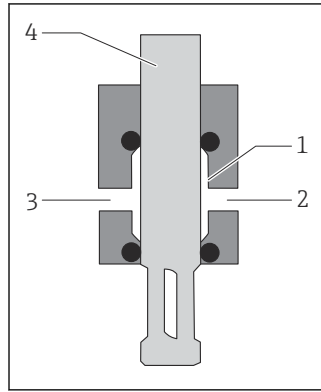

- 1 Service chamber
- 2 Service chamber outlet
- 3 Service chamber inlet
- 4 Sensor guide

In measuring position, the service chamber is separated from the process by the process seals and sensor guide. No process medium can get into the service chamber.

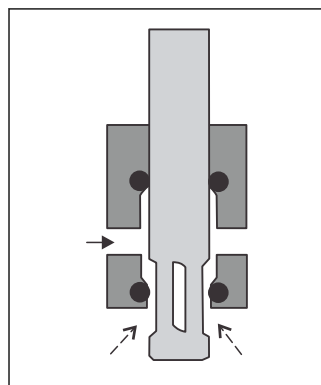

When the assembly is moving from measuring to service position (or the other way around), the service chamber is no longer separated from the process. Now process medium can get into the service chamber.

To prevent this, you can rinse the service chamber with a sealing medium via the service chamber inlet. This also means that process medium, which may contain solid particles, does not need to be removed via the service chamber.

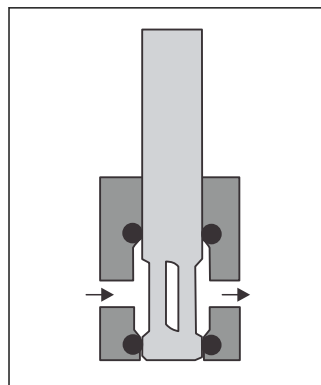

In service position, the service chamber is separated from the process.

Cleanfit Control

Integration in an automatic measuring system

Cleanfit Control converts electrical signals into pneumatic signals. Signals coming from the relays or outputs of the transmitter are used to control pneumatically-operated retractable assemblies or pumps. Pilot valves are used for this purpose.

Cleanfit Control allows automatic cleaning of sensors installed in retractable assemblies. This means that sensor performance can be maintained at a high level without any interruption to the process.

It is the function of the Cleanfit Control CYC25 to integrate the actuators into the cleaning program in a safety-oriented manner. That is why the actuators, i.e. assembly, valves and pumps, are not connected directly via the relays to the Liquiline CM44x. Instead they are connected to the Cleanfit Control CYC25. The 24V DC power supply to these actuators, as well as the compressed air supply, are provided by the customer.

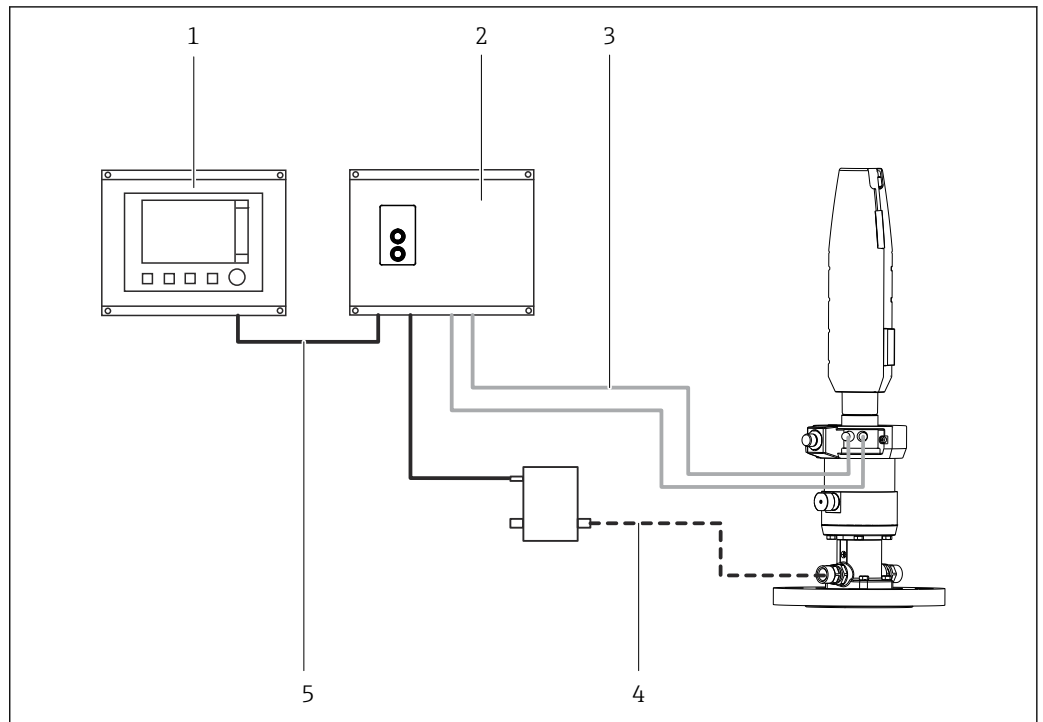

7 Cleaning control with Cleanfit Control

- 1 Liquiline CM44x
- 2 Cleanfit Control CYC25
- 3 Pneumatic connection
- 4 Cleaning medium
- 5 Electrical connection

Cleanfit Control is available as an accessory.

Control unit Air-Trol 500

Air-Trol 500 allows you to move all pneumatically-controlled retractable assemblies manually.

- Easy installation
- Purely pneumatic functional unit
- Measuring or service mode of assembly:
 - Simple toggle switch
 - Optical display
- Push-button switch for pneumatic valve for cleaning agent, used to clean sensor

Air-Trol 500 is available as accessory.

Mounting

Sensor selection	Depending on the assembly version.		
	Short version	Gel sensors, ISFET	120 mm
		Gel sensors, ISFET	225 mm
		KCl sensors	225 mm
	Long version	Gel sensors, ISFET	225 mm
		Gel sensors, ISFET	360 mm
	Immersion chamber version (short)	Gel sensors, ISFET	225 mm
		KCl sensors	360 mm
	Immersion chamber version (long)	Gel+KCl	360 mm
Special mounting instructions	Limit position switches		
	Switching element function:	NAMUR NC contact (inductive)	
	Switching distance:	1.5 mm (0.06 ")	
	Nominal voltage:	8 V	
	Switching frequency:	0 to 5000 Hz	
	Housing material:	Stainless steel	
	Output interface terminals	NAMUR	
	Limit position switches (inductive conductivity sensors)	Pepperl+Fuchs NJ1.5-6.5-15-N-Y180094	

Environment



Ambient temperature range	-10 to +70 °C (+10 to +160 °F)
Storage temperature	-10 to +70 °C (+10 to +160 °F)

Process

Process temperature range	For all materials except PVDF, PVDF conductive and PP -10 to 140 °C (14 to 284 °F) PVDF and PVDF conductive -10 to ¹⁰⁰ / ₉₀ °C (14 to ²¹² / ₁₉₄ °F) PP 0 to 60 °C (32 to 140 °F)	
Process pressure range	Pneumatic drive	16 bar (232 psi) up to 140 °C (284 °F)
	Manual drive (PP version may vary)	8 bar (116 psi) to 140 °C (284 °F)
	 The service life of the seals is reduced if process temperatures are constantly high or if SIP is used. The other process conditions may also reduce the service life of the seals.	

Process pressure for pneumatic drive

Materials	Basic version	Immersion chamber version
1.4404, Alloy C22, PEEK	16 bar (232 psi) to 140 °C (284 °F)	16 bar (232 psi) to 140 °C (284 °F)
PVDF, PVDF conductive	16 bar (232 psi) to 100 °C (212 °F)	4 bar (58 psi) to 90 °C (194 °F)
PP (polypropylene)	6 bar (87 psi) to 20 °C (86 °F)	-

-  The service life of the seals is reduced if process temperatures are constantly high or if SIP is used. The other process conditions may also reduce the service life of the seals.
-  Depending on the version, the process pressure must be reduced to insert/retract the assembly.

Process pressure for manual drive

Materials	Basic version	Immersion chamber version
1.4404, Alloy C22, PEEK	8 bar (116 psi) to 140 °C (284 °F)	8 bar (116 psi) to 140 °C (284 °F)
PVDF, PVDF conductive	8 bar (116 psi) to 100 °C (212 °F)	4 bar (58 psi) to 90 °C (194 °F)
PP (polypropylene)	6 bar (87 psi) to 20 °C (86 °F)	-

-  The service life of the seals is reduced if process temperatures are constantly high or if SIP is used. The other process conditions may also reduce the service life of the seals.

Pressure-temperature ratings

Manual and pneumatic drive, insertion/retraction up to 6 bar

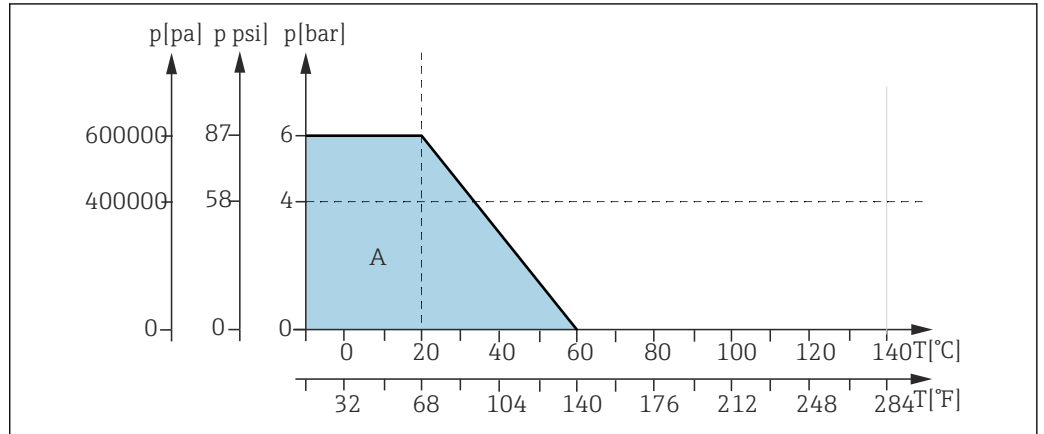

 8 Pressure/temperature ratings for basic version for the material PP (CPA871\-*H*)

A Basic version

Manual drive, insertion/retraction up to 8 bar

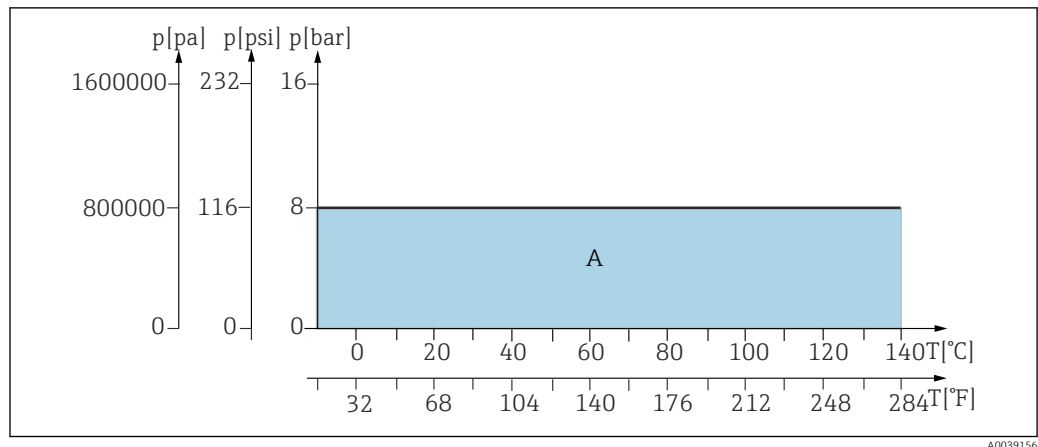

9 Pressure temperature ratings for basic and immersion chamber version for materials 1.4404, Alloy C22 and PEEK

A Basic and immersion chamber version

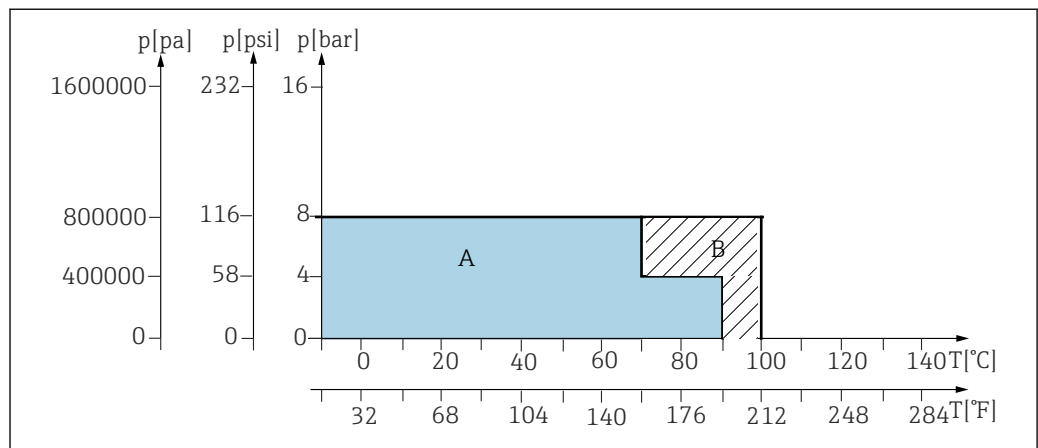

10 Pressure temperature ratings for basic version for materials PVDF and conductive PVDF

A Immersion chamber version

B Basic version

Pneumatic drive, insertion/retraction up to 8 bar (static pressure resistance up to 16 bar)

NOTICE

Process seal can be damaged if the pressure during insertion/retraction is too high.

Medium escaping from the assembly

- ▶ Assembly insertion/retraction at 8 bar.

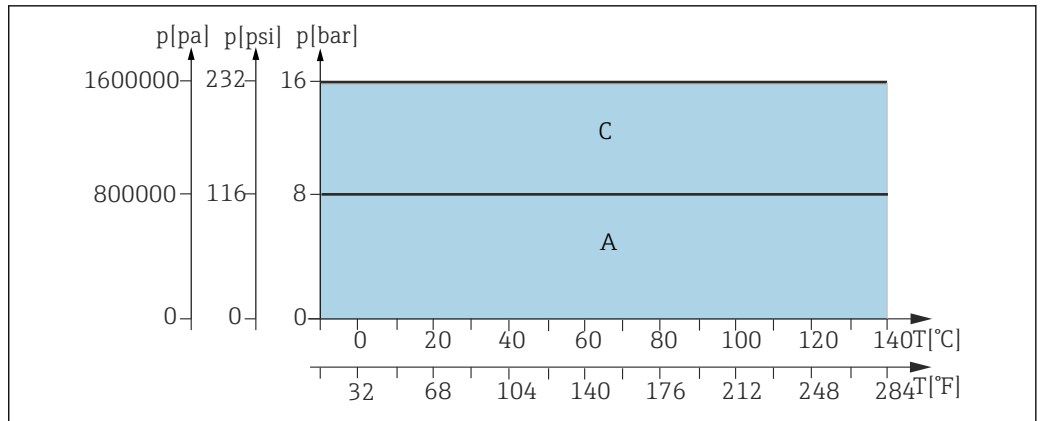

A0039268

11 Pressure/temperature ratings for basic and immersion chamber version for materials 1.4404, Alloy C22 and PEEK (CPA871-****G/H****)

- A Basic and immersion chamber version
- C Static range, assembly insertion/retraction not permitted

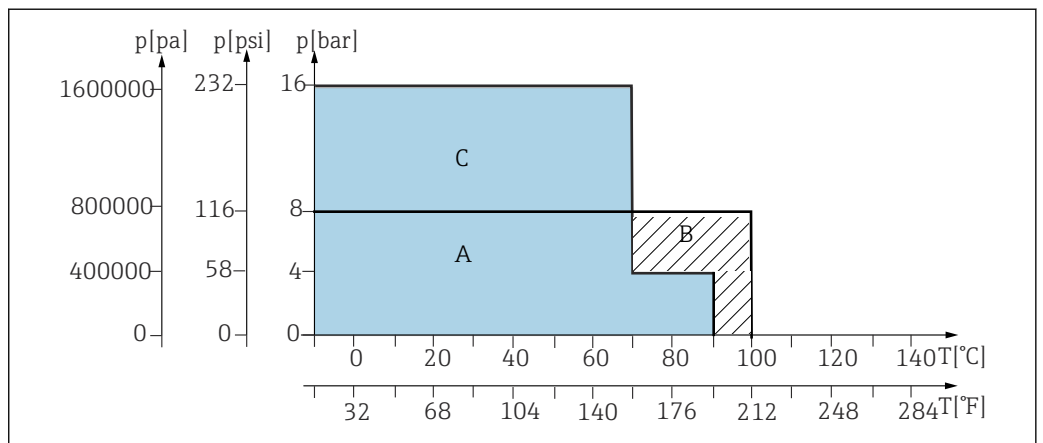

A0039267

12 Pressure/temperature ratings for basic version for materials PVDF and PVDF conductive (CPA871-****G/H****)

- A Immersion chamber version
- B Basic version
- C Static range, assembly insertion/retraction not permitted

Pneumatic drive, insertion/retraction up to 16 bar

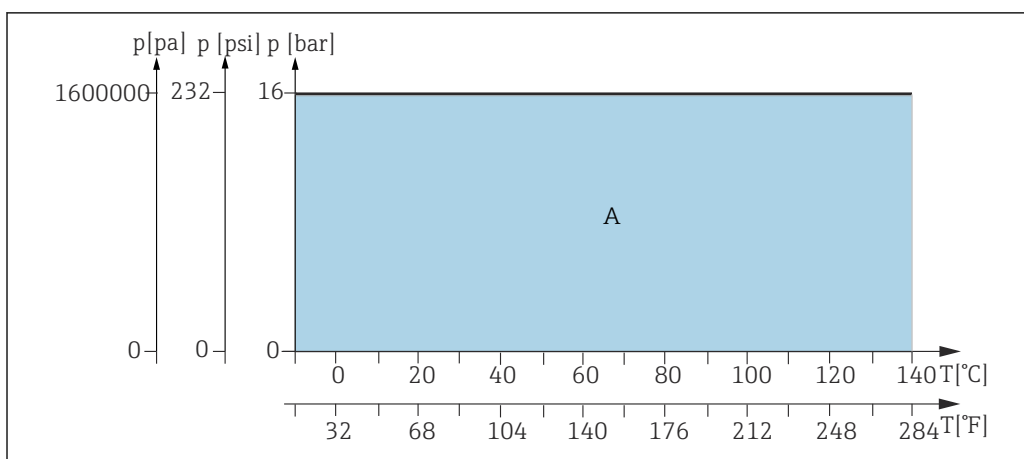

A0039157

13 Pressure/temperature ratings for basic and immersion chamber version for materials 1.4404, Alloy C22 and PEEK (CPA871-****E/F****)

A Basic and immersion chamber version

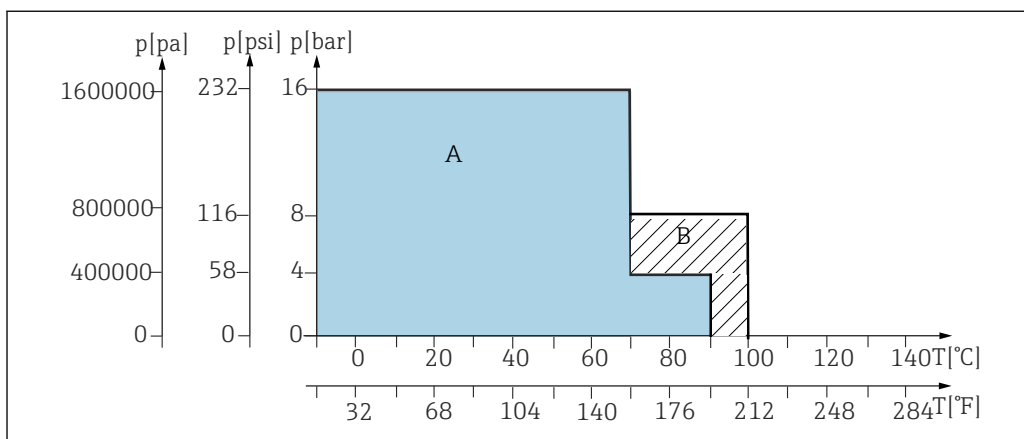

A0039162

14 Pressure/temperature ratings for basic version for materials PVDF and PVDF conductive (CPA871-****E/F****)

A Immersion chamber version

B Basic version

Mechanical construction

Design, dimensions

Short version

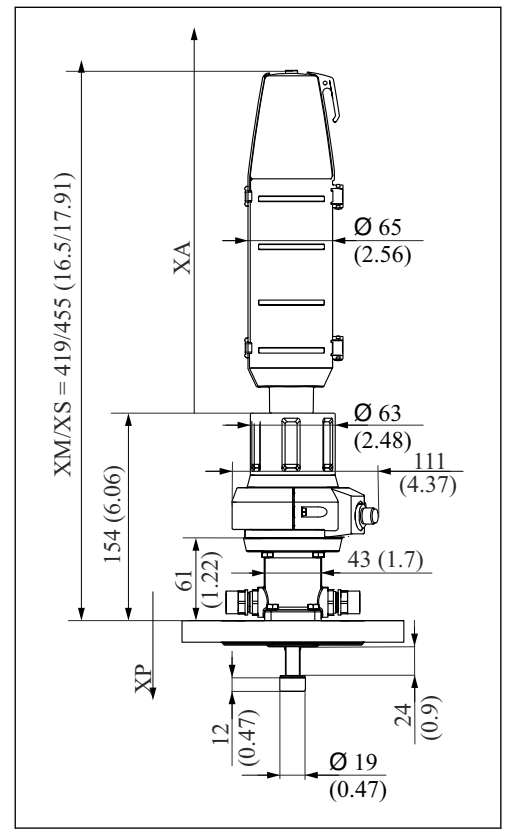
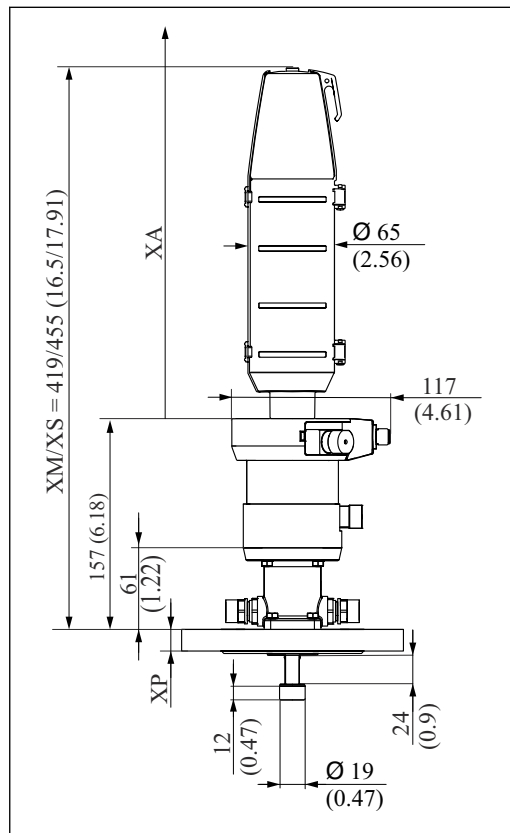

15 Pneumatic drive, short version, dimensions in mm (in)

16 Manual drive, short version, dimensions in mm (in)

XM Assembly in measuring position

XS Assembly in service position

XP Height of particular process connection (see table below)

XA Necessary mounting distance for sensor replacement

A free path length *XA* above the drive is required to replace the sensors:

XA is 280 mm (11.02") for 120 mm sensors

XA is 408 mm (15.94") for 225 mm sensors

Long version

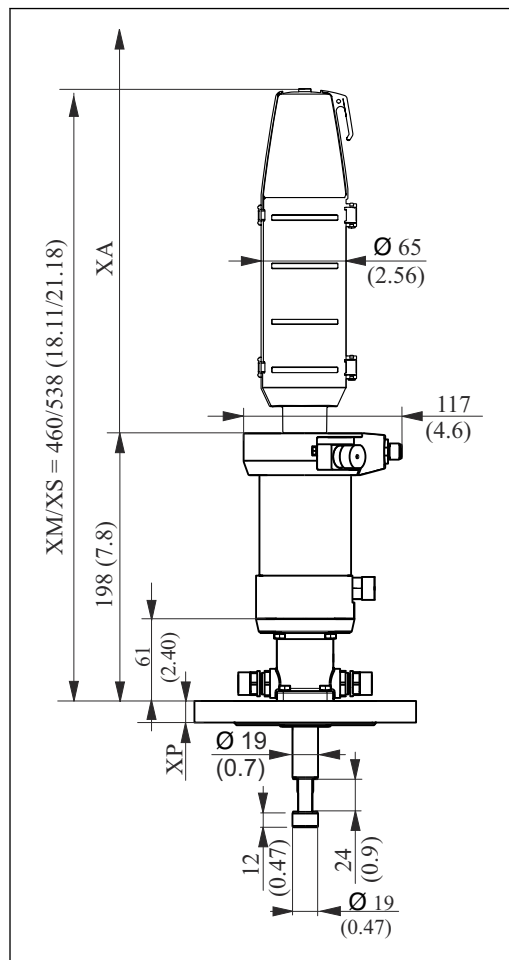

A0023895

17 Pneumatic drive, long version, dimensions in mm (in)

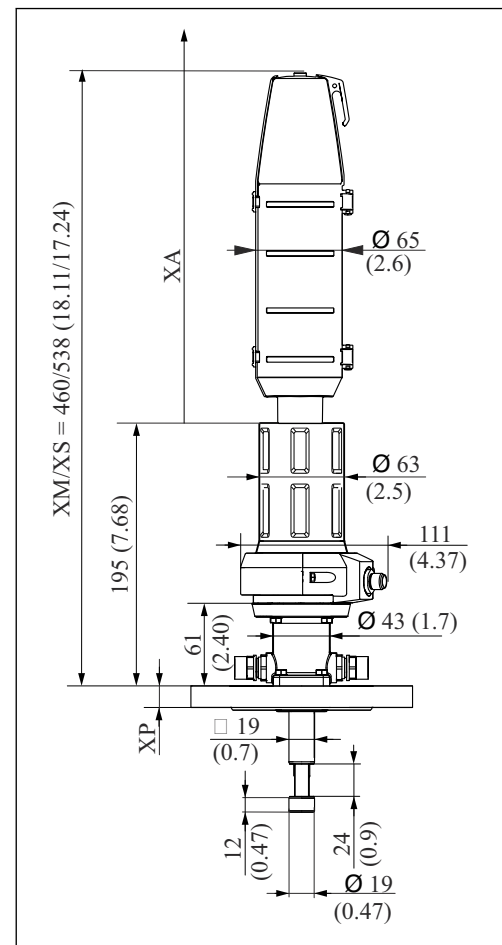

A0023898

18 Manual drive, long version, dimensions in mm (in)

XM Assembly in measuring position

XS Assembly in service position

XP Height of particular process connection (see table below)

XA Necessary mounting distance for sensor replacement

A free path length *XA* above the drive is required to replace the sensors:

XA is 360 mm (14.17") for 225 mm sensors

Immersion chamber version

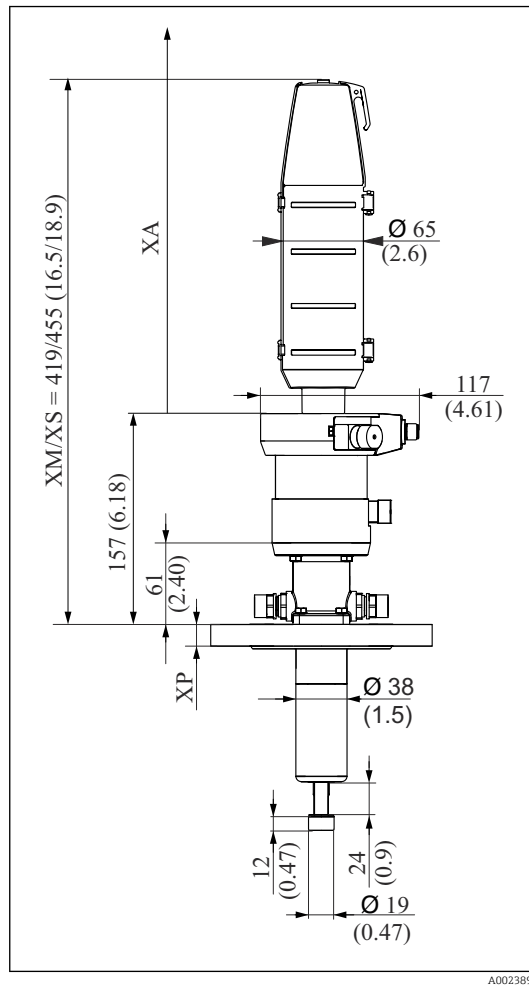

19 Immersion chamber version with pneumatic drive, dimensions in mm (in)

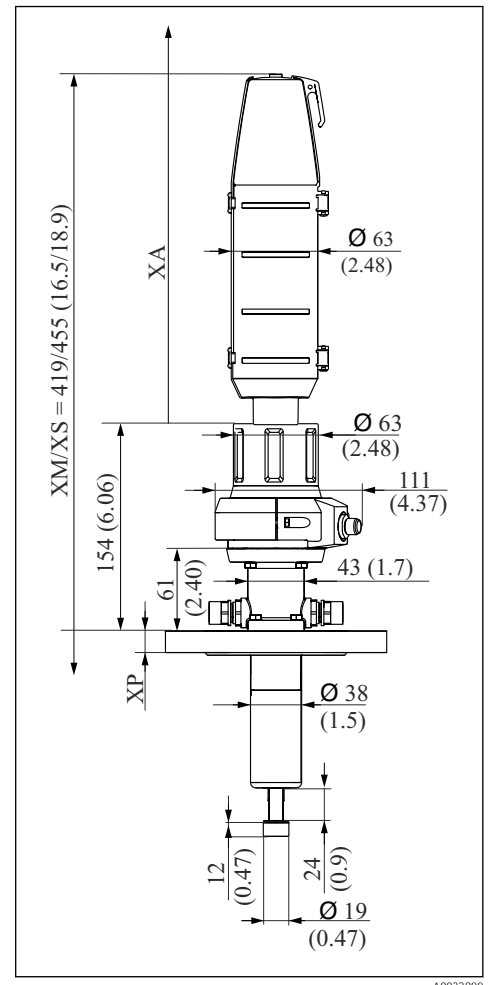

20 Immersion chamber version with manual drive, dimensions in mm (in)

XM Assembly in measuring position

XS Assembly in service position

XP Height of particular process connection (see table below)









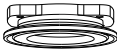
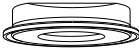

XA Necessary mounting distance for sensor replacement

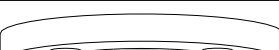
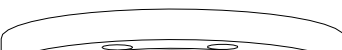
A free path length *XA* above the drive is required to replace the sensors:

XA is 280 mm (11.02") for 225 mm sensors

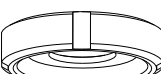
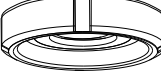
XA is 570 mm (22.44") for 360 mm sensors

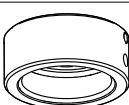
Process connection height

Process connection		Height XP in mm (in)
CB Clamp 2" ISO2852, ASME BPE-2012	 A0024100	16 (0.63)
CC Clamp 2½" ISO2852, ASME BPE-2012	 A0024101	16 (0.63)
FA Flange DN 40 PN16, EN1092-1	 A0024102	18 (0.71)
FB Flange DN 50 PN16, EN1092-1	 A0024103	18 (0.71)
FC Flange DN 80 PN10, EN1092-1	 A0024104	20 (0.79)
FD Flange 2" 150 lbs, ASME B16.5	 A0024105	19.1 (0.75)
FE Flange 3" 150 lbs, ASME B16.5	 A0024106	23.8 (0.94)
FF 10K50, JIS B2220	 A0024107	16 (0.63)
FG 10K80, JIS B2220	 A0024108	18 (0.71)
MA Dairy fitting DN 50 DIN 11851	 A0024109	15.5 (0.61)
MB Dairy fitting DN 65 DIN 11851	 A0024110	15.5 (0.61)
HB Thread NPT 1½"	 A0024111	40.5 (1.57)
NA Thread ISO 228 G1¼	 A0039368	31.1 (1.22)
Union nut DN25 G1¼ internal thread	 A0054908	22.5 (0.89)

Immersion depths

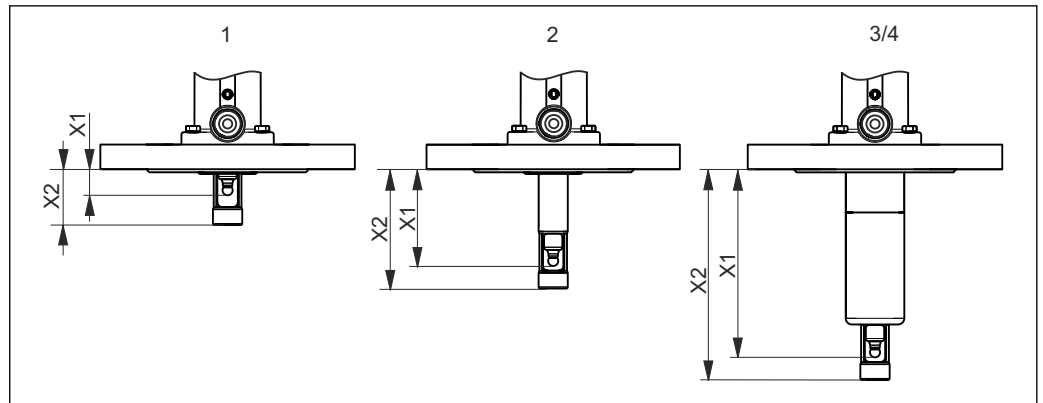

A0023893

21 Immersion depths in mm (in)

- 1 Short stroke, 36 mm (1.42 in)
- 2 Long stroke, 78 mm (3.07 in)
- 3 Immersion chamber version, 99 mm (3.89 in) / 36 mm (1.42 in)
- 4 Long immersion chamber version, 151 mm (5.94 in) / 36 mm (1.42 in)

Versions

Process connection		1	2	3	4
CB Clamp ISO2852 ASME BPE-2012 2"	X1	14.9 (0.59)	61.0 (2.40)	119.9 (4.72)	171.9 (6.76)
	X2	34.2 (1.35)	75.7 (2.98)	134.6 (5.30)	186.6 (7.35)
CC Clamp ISO2852 ASME BPE-2012 2½"	X1	14.9 (0.59)	61.0 (2.40)	119.9 (4.72)	171.9 (6.76)
	X2	34.2 (1.35)	75.7 (2.98)	134.6 (5.30)	186.6 (7.35)
FA Flange DN 40 EN1092-1	X1	14.9 (0.59)	61.0 (2.40)	119.9 (4.72)	171.9 (6.76)
	X2	34.2 (1.35)	75.7 (2.98)	134.6 (5.30)	186.6 (7.35)
FB Flange DN 50 EN1092-1	X1	14.9 (0.59)	61.0 (2.40)	119.9 (4.72)	171.9 (6.76)
	X2	34.2 (1.35)	75.7 (2.98)	134.6 (5.30)	186.6 (7.35)
FC Flange DN 80 EN1092-1	X1	12.9 (0.51)	59.0 (2.32)	117.9 (4.64)	169.9 (6.69)
	X2	32.2 (1.27)	73.7 (2.90)	132.6 (5.22)	184.6 (7.27)
FD Flange 2" 150 lbs ASME B16.5	X1	13.8 (0.54)	59.9 (2.36)	118.9 (4.68)	170.9 (6.73)
	X2	33.1 (1.30)	74.6 (2.94)	133.6 (5.26)	185.6 (7.30)
FE Flange 3" 150 lbs ASME B16.5	X1	-	-	114.1 (4.49)	166.1 (6.54)
	X2	-	-	128.8 (5.07)	180.8 (7.11)
FF Flange 10K50 JIS B2220	X1	14.4 (0.57)	61.3 (2.41)	120.2 (4.73)	172.2 (6.78)
	X2	33.7 (1.33)	76.0 (2.99)	134.9 (5.31)	186.9 (7.36)
FG Flange 10K80 JIS B2220	X1	14.4 (0.57)	60.5 (2.38)	119.4 (4.70)	171.4 (6.75)
	X2	33.7 (1.33)	75.2 (2.96)	134.1 (5.28)	186.1 (7.33)
HB Thread NPT 1½"	X1	-	63.0 (2.48)	121.9 (4.80)	173.9 (6.85)
	X2	-	77.7 (3.06)	136.6 (5.38)	188.6 (7.40)
MA Dairy fitting DN 50 DIN11851	X1	15.4 (0.61)	61.5 (2.42)	120.4 (4.74)	172.4 (6.79)
	X2	34.7 (1.37)	76.2 (3.00)	135.1 (5.32)	187.1 (6.37)
MB Dairy fitting DN 65 DIN11851	X1	15.4 (0.61)	61.5 (2.42)	120.4 (4.74)	172.4 (6.79)
	X2	34.7 (1.37)	76.2 (3.00)	135.1 (5.32)	187.1 (6.37)
NA thread ISO228 G 1½"	X1	-	61.5 (2.42)	-	-
	X2	-	76.2 (3.00)	-	-
	X3	-	20.6 (0.81)	-	-

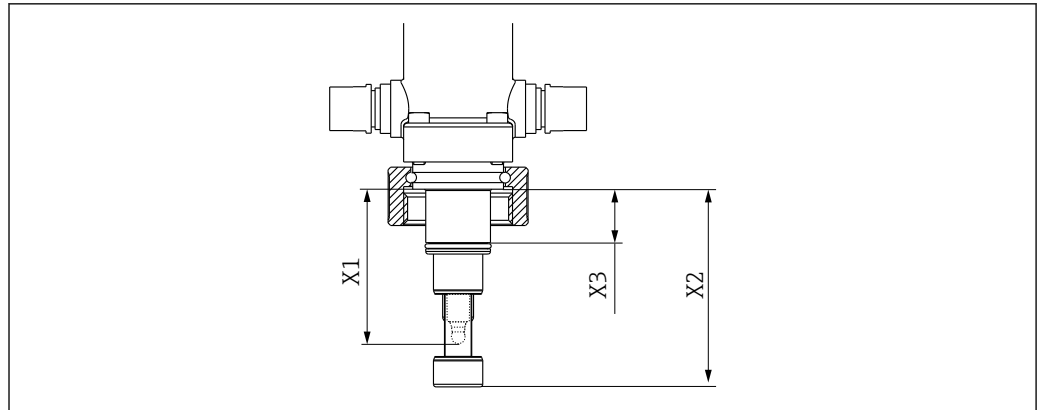

A0039342

22 Immersion depth in mm (in) for process connection NA thread ISO 228 G1 1/4

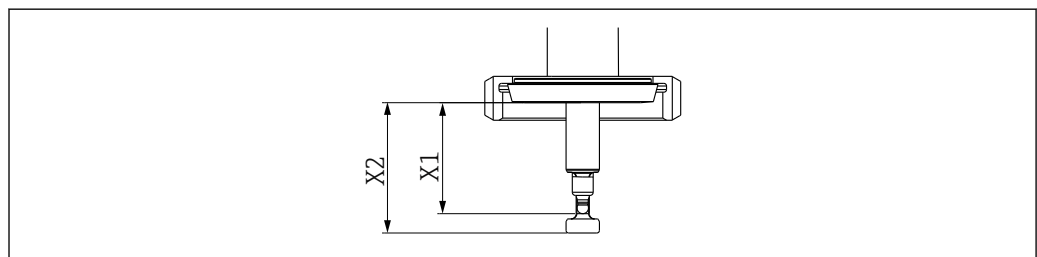

A0048452

23 Immersion depth in mm (in) for process connection MA and MB thread

Rinse chamber volume	Volume cm ³ (in ³) (max.)	Volume cm ³ (in ³) (min.)
Single chamber	12.02 (0.73)	2.81 (0.17)
Immersion chamber, short	15.75 (0.96)	6.73 (0.41)
Immersion chamber, long	17.14 (1.05)	8.12 (0.5)

Weight

Depends on version:

Pneumatic drive: 3.8 to 6 kg (8.4 to 13.2 lbs) depending on version

Manual drive: 3 to 4.5 kg (6.6 to 9.9 lbs) depending on version

Materials

In contact with medium	
Seals:	EPDM / FKM / FFKM
Immersion tube, process connection, service chamber:	Stainless steel 1.4404 (AISI 316L) Ra < 0.76 / PEEK / Alloy C22 Ra < 0.76 / PVDF / PVDF conductive / PP
Rinse connections:	Stainless steel 1.4404 (AISI 316L) or Alloy C22

Not in contact with medium	
Manual drive:	Stainless steel 1.4301 (AISI 304) or 1.4404 (AISI 316L), plastics PPS CF15, PBT, PP
Pneumatic drive:	Stainless steel 1.4301 (AISI 304) or 1.4404 (AISI 316L), plastics PBT, PP

Rinse connections

Surface finish may vary depending on the manufacturing process.

Certificates and approvals

Current certificates and approvals for the product are available at www.endress.com on the relevant product page:

1. Select the product using the filters and search field.
2. Open the product page.
3. Select **Downloads**.

CRN (optional)

As the assembly can be operated with a nominal pressure greater than 15 psi (approx. 1 bar), it has been registered with a CRN (Canadian Registration Number) in all Canadian provinces in accordance with CSA B51 ("Boiler, pressure vessel, and pressure piping code"; category F). The CRN can be found on the nameplate.

DGRL- 2014/68/EU / PED- 2014/68/EU

The assembly has been manufactured according to good engineering practice as per Article 4, Paragraph 3 of the Pressure Equipment Directive 2014/68/EU and is therefore not required to bear the CE label.

Order information

Ordering instructions

Create the order code for the assembly as follows:

1. Is the assembly used in the hazardous or non-hazardous area?
2. Select the drive type and the limit position switches.
3. Select the type of service chamber.
4. What material should the wetted seals be made of?
5. What material should the wetted surfaces be made of?
6. Select the suitable process connection.
7. Which connections should the service chamber have?

Order the accessories as follows:

- If you wish to order the accessories together with the assembly, then use the accessory code of the product structure.
- If you only wish to order accessories, then use the order numbers from the "Accessories" section.

Product page

www.endress.com/cpa871

Product Configurator

1. **Configure:** Click this button on the product page.
 2. Select **Extended selection**.
 - ↳ The Configurator opens in a separate window.
 3. Configure the device according to your requirements by selecting the desired option for each feature.
 - ↳ In this way, you receive a valid and complete order code for the device.
 4. **Accept:** Add the configured product to the shopping cart.
-  For many products, you also have the option of downloading CAD or 2D drawings of the selected product version.
5. **CAD:** Open this tab.
 - ↳ The drawing window is displayed. You have a choice between different views. You can download these in selectable formats.

Scope of delivery

The scope of delivery comprises:

- Ordered version of assembly
- Operating Instructions

Accessories

The following are the most important accessories available at the time this documentation was issued.

Listed accessories are technically compatible with the product in the instructions.

1. Application-specific restrictions of the product combination are possible.
Ensure conformity of the measuring point to the application. This is the responsibility of the operator of the measuring point.
2. Pay attention to the information in the instructions for all products, particularly the technical data.
3. For accessories not listed here, please contact your Service or Sales Center.

The following accessories can be ordered via the product structure or the XPC0001 spare part structure:

- Weld-in adapter G1¼, straight, 35 mm, 1.4435 (AISI 316 L), safety nozzle
- Weld-in adapter G1¼, angled, 35 mm, 1.4435 (AISI 316 L), safety nozzle

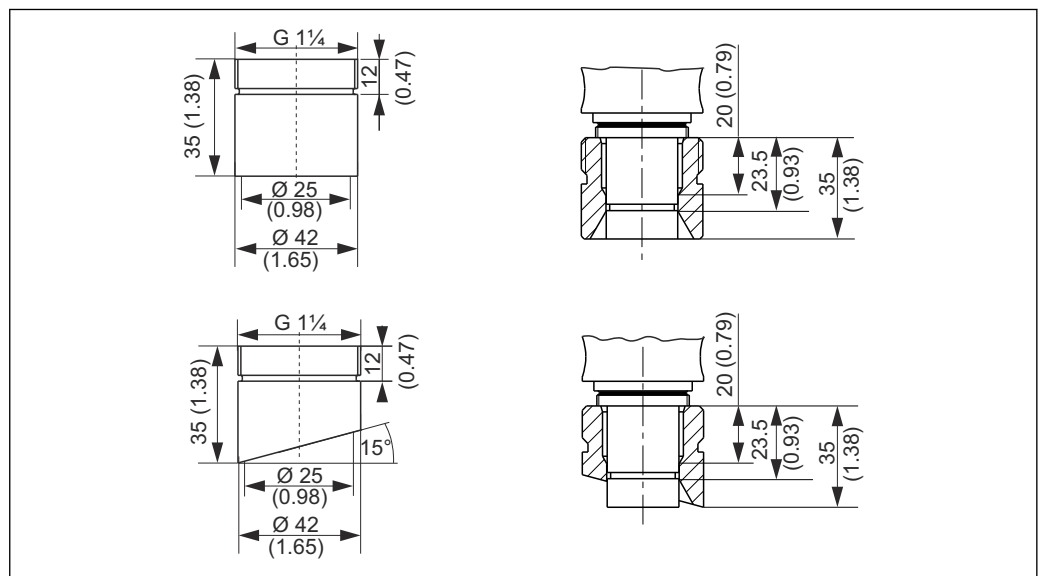

A0028744

■ 24 Weld-in adapter (safety nozzle), dimensions in mm (in)

- Dummy plug G1¼, 1.4435 (AISI 316 L), FPM - FDA
- Sensor dummy 120 mm, 1.4435 (AISI 316 L), Ra = 0.38 µm
- Sensor dummy 225 mm, 1.4435 (AISI 316 L), Ra = 0.38 µm
- Sensor dummy 360 mm, 1.4435 (AISI 316 L), Ra = 0.38 µm
- Kit, seals for non-wetted parts
- Kit, FKM seals, G1¼, wetted parts
- Kit, FKM seals, immersion chamber version, wetted parts
- Kit, seal, wetted, EPDM
- Kit, seal, wetted, FKM
- Kit, seal, FFKM, basic, wetted
- Cable, plug-in, limit switch, M12, 5 m
- Cable, plug-in, limit switch, M12, 10 m
- Tool in case for installation/removal
- Kit, Klüber Paraliq GTE 703 lubricant (60g)
- Output interface terminals, version: CPA871-620-R7
NAMUR terminals for limit position switches
 - Operation of 8V DC feedback signals on 24V DC devices
 - Suitable for top-hat rail mounting

Device-specific accessories

Sensors

*pH sensors***Memosens CPS11E**

- pH sensor for standard applications in process and environmental engineering
- Digital with Memosens 2.0 technology
- Product Configurator on the product page: www.endress.com/cps11e



Technical Information TI01493C

Orbisint CPS11D / CPS11

- pH sensor for process technology
- With dirt-repellent PTFE diaphragm
- Product Configurator on the product page: www.endress.com/cps11d or www.endress.com/cps11



Technical Information TI00028C

Memosens CPS31E

- pH sensor for standard applications in drinking water and swimming pool water
- Digital with Memosens 2.0 technology
- Product Configurator on the product page: www.endress.com/cps31e



Technical Information TI01574C

Memosens CPS41E

- pH sensor for process technology
- With ceramic junction and KCl liquid electrolyte
- Digital with Memosens 2.0 technology
- Product Configurator on the product page: www.endress.com/cps41e



Technical Information TI01495C

Ceraliquid CPS41D / CPS41

- pH electrode with ceramic junction and KCl liquid electrolyte
- Product Configurator on the product page: www.endress.com/cps41d or www.endress.com/cps41



Technical Information TI00079C

Memosens CPS61E

- pH sensor for bioreactors in life sciences and for the food industry
- Digital with Memosens 2.0 technology
- Product Configurator on the product page: www.endress.com/cps61e



Technical Information TI01566C

Memosens CPS71E

- pH sensor for chemical process applications
- Digital with Memosens 2.0 technology
- Product Configurator on the product page: www.endress.com/cps71e



Technical Information TI01496C

Ceragel CPS71D / CPS71

- pH electrode with reference system including ion trap
- Product Configurator on the product page: www.endress.com/cps71d or www.endress.com/cps71



Technical Information TI00245C

Memosens CPS91E

- pH sensor for heavily polluted media
- Digital with Memosens 2.0 technology
- Product Configurator on the product page: www.endress.com/cps91e



Technical Information TI01497C

Orbipore CPS91D / CPS91

- pH electrode with open aperture for media with high dirt load
- Product Configurator on the product page: www.endress.com/cps91d or www.endress.com/cps91



Technical Information TI00375C

ORP sensors

Memosens CPS12E

- ORP sensor for standard applications in process and environmental engineering
- Digital with Memosens 2.0 technology
- Product Configurator on the product page: www.endress.com/cps12e



Technical Information TI01494C

Orbisint CPS12D / CPS12

- ORP sensor for process technology
- Product Configurator on the product page: www.endress.com/cps12d or www.endress.com/cps12



Technical Information TI00367C

Memosens CPS42E

- ORP sensor for process technology
- Digital with Memosens 2.0 technology
- Product Configurator on the product page: www.endress.com/cps42e



Technical Information TI01575C

Ceraliquid CPS42D / CPS42

- ORP electrode with ceramic junction and KCl liquid electrolyte
- Product Configurator on the product page: www.endress.com/cps42d or www.endress.com/cps42



Technical Information TI00373C

Memosens CPS72E

- ORP sensor for chemical process applications
- Digital with Memosens 2.0 technology
- Product Configurator on the product page: www.endress.com/cps72e



Technical Information TI01576C

Ceragel CPS72D / CPS72

- ORP electrode with reference system including ion trap
- Product Configurator on the product page: www.endress.com/cps72d or www.endress.com/cps72



Technical Information TI00374C

ISFET pH sensors

Memosens CPS47D

- Sterilizable and autoclavable ISFET sensor for pH measurement
- Refillable KCl liquid electrolyte
- Product Configurator on the product page: www.endress.com/cps47d



Technical Information TI01412C

Memosens CPS77D

- Sterilizable and autoclavable ISFET sensor for pH measurement
- Product Configurator on the product page: www.endress.com/cps77d



Technical Information TI01396

*Combined pH/ORP sensors***Memosens CPS16E**

- pH/ORP sensor for standard applications in process technology and environmental engineering
- Digital with Memosens 2.0 technology
- Product Configurator on the product page: www.endress.com/cps16e



Technical Information TI01600C

Memosens CPS16D

- Combined pH/ORP sensor for process technology
- With dirt-repellent PTFE diaphragm
- With Memosens technology
- Product Configurator on the product page: www.endress.com/cps16d



Technical Information TI00503C



The 120 mm version in the CPS16D is not suitable.

Memosens CPS76E

- pH/ORP sensor for process technology
- Digital with Memosens 2.0 technology
- Product Configurator on the product page: www.endress.com/cps76e



Technical Information TI01601C

Memosens CPS76D

- Combined pH/ORP sensor for process technology
- Hygienic and sterile applications
- With Memosens technology
- Product Configurator on the product page: www.endress.com/cps76d



Technical Information TI00506C

Memosens CPS96E

- pH/ORP sensor for heavily polluted media and suspended solids
- Digital with Memosens 2.0 technology
- Product Configurator on the product page: www.endress.com/cps96e



Technical Information TI01602C

Memosens CPS96D

- Combined pH/ORP sensor for chemical processes
- With poison-resistant reference with ion trap
- With Memosens technology
- Product Configurator on the product page: www.endress.com/cps96d



Technical Information TI00507C

*Conductivity sensors***Memosens CLS82E**

- Hygienic conductivity sensor
- Digital with Memosens 2.0 technology
- Product Configurator on the product page: www.endress.com/cls82e



Technical Information TI01529C

Memosens CLS82D

- Four-electrode sensor
- With Memosens technology
- Product Configurator on the product page: www.endress.com/cls82d



Technical Information TI01188C

Oxygen sensors

Oxymax COS22E

- Sterilizable sensor for dissolved oxygen
- Digital with Memosens 2.0 technology
- Product Configurator on the product page: www.endress.com/cos22e



Technical Information TI00446C

Oxymax COS22D / COS22

- Sterilizable sensor for dissolved oxygen
- With Memosens technology or as an analog sensor
- Product Configurator on the product page: www.endress.com/cos22d or www.endress.com/cos22



Technical Information TI00446C

Absorption sensor

OUSBT66

- NIR absorption sensor for measuring cell growth and biomass
- Sensor version suitable for pharmaceutical industry
- Product Configurator on the product page: www.endress.com/ousbt66



Technical Information TI00469C

Service-specific accessories

Cleaning systems

Air-Trol 500

- Control unit for Cleanfit retractable assemblies
- Order No. 50051994



Technical Information TI00038C/07/EN

Cleanfit Control CYC25

- Converts electrical signals into pneumatic signals to control pneumatically-operated retractable assemblies or pumps in conjunction with Liquiline CM44x
- Wide range of control options
- Product Configurator on the product page: www.endress.com/cyc25



Technical Information TI01231C

Liquiline Control CDC90

- Fully automatic cleaning and calibration system for pH and ORP measuring points in all industries
- Cleaned, validated, calibrated and adjusted
- Product Configurator on the product page: www.endress.com/cdc90



Technical Information TI01340C

Flow vessel

- Flange DN 25 ISO 1092-2 PN16
- Material: stainless steel 1.4404 (AISI 316 L)
- Can be ordered with assembly with G 1 1/4" process connection CPA871-+++C+ANA++NI or as spare part XPC0003-V+QI

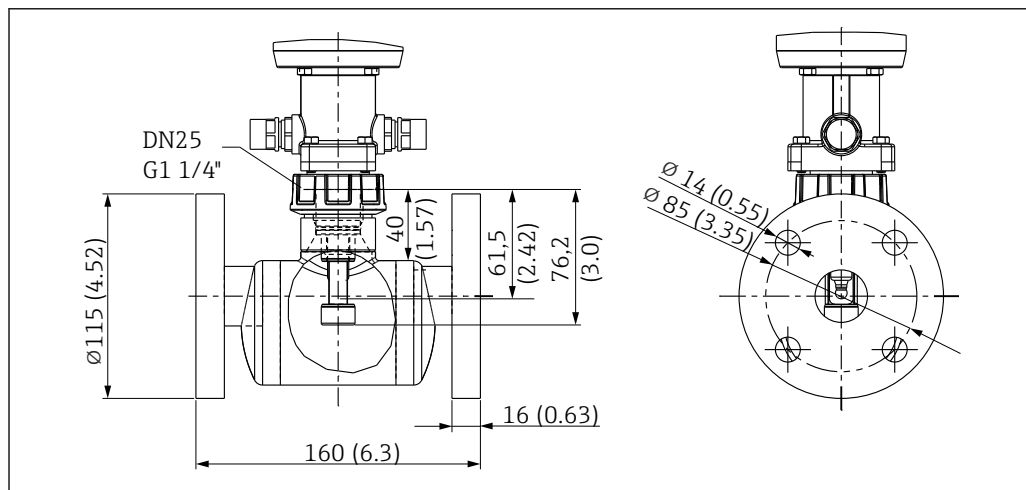

25 Dimensions in mm (in)

i Dummy plug is available for maintenance purposes

**Installation material for
rinse connections**

Kit, water filter

- Water filter (dirt trap) 100 µm, complete, incl. angle bracket
- Order No. 71390988

Pressure reducer kit

- Complete, incl. manometer and angle bracket
- Order No. 71390993

Hose connection set G $\frac{1}{4}$, DN 12

- 1.4404 (AISI 316L) 2 x
- Order No. 51502808

Hose connection set G $\frac{1}{4}$, DN 12

- PVDF (2 x)
- Order No. 50090491



www.addresses.endress.com
