

# Operating Instructions

## Cleanfit CPA875

Retractable process assembly for sterile and hygienic applications







## Table of contents









<b>1</b>	<b>About this document</b> .....	<b>4</b>	<b>11</b>	<b>Technical data</b> .....	<b>67</b>
1.1	Safety information .....	4	11.1	Mounting .....	67
1.2	Symbols used .....	4	11.2	Environment .....	67
1.3	Symbols on the device .....	4	11.3	Process .....	67
1.4	Documentation .....	4	11.4	Mechanical construction .....	70
<b>2</b>	<b>Basic safety instructions</b> .....	<b>5</b>	<b>Index</b> .....		<b>72</b>
2.1	Requirements for the personnel .....	5			
2.2	Intended use .....	5			
2.3	Workplace safety .....	5			
2.4	Operational safety .....	6			
2.5	Product security .....	6			
<b>3</b>	<b>Product description</b> .....	<b>7</b>			
3.1	Product design .....	7			
<b>4</b>	<b>Incoming acceptance and product identification</b> .....	<b>9</b>			
4.1	Incoming acceptance .....	9			
4.2	Scope of delivery .....	9			
4.3	Product identification .....	10			
<b>5</b>	<b>Mounting</b> .....	<b>11</b>			
5.1	Mounting requirements .....	11			
5.2	Mounting the assembly .....	24			
5.3	Post-mounting check .....	38			
<b>6</b>	<b>Commissioning</b> .....	<b>39</b>			
6.1	Preliminaries .....	39			
<b>7</b>	<b>Operation</b> .....	<b>40</b>			
7.1	Adapting the assembly to the process conditions .....	40			
<b>8</b>	<b>Maintenance</b> .....	<b>43</b>			
8.1	Maintenance schedule .....	43			
8.2	Maintenance work .....	44			
<b>9</b>	<b>Repair</b> .....	<b>58</b>			
9.1	General information .....	58			
9.2	Spare parts .....	58			
9.3	Return .....	58			
9.4	Disposal .....	59			
<b>10</b>	<b>Accessories</b> .....	<b>60</b>			
10.1	Device-specific accessories .....	61			
10.2	Service-specific accessories .....	64			
10.3	Installation material for rinse connections ...	66			

# 1 About this document



## 1.1 Safety information

Structure of information	Meaning
 <b>DANGER</b> <b>Causes (/consequences)</b> If necessary, Consequences of non-compliance (if applicable) ► Corrective action	This symbol alerts you to a dangerous situation. Failure to avoid the dangerous situation <b>will</b> result in a fatal or serious injury.
 <b>WARNING</b> <b>Causes (/consequences)</b> If necessary, Consequences of non-compliance (if applicable) ► Corrective action	This symbol alerts you to a dangerous situation. Failure to avoid the dangerous situation <b>can</b> result in a fatal or serious injury.
 <b>CAUTION</b> <b>Causes (/consequences)</b> If necessary, Consequences of non-compliance (if applicable) ► Corrective action	This symbol alerts you to a dangerous situation. Failure to avoid this situation can result in minor or more serious injuries.
<b>NOTICE</b> <b>Cause/situation</b> If necessary, Consequences of non-compliance (if applicable) ► Action/note	This symbol alerts you to situations which may result in damage to property.

## 1.2 Symbols used

	Additional information, tips
	Permitted
	Recommended
	Not permitted or not recommended
	Reference to device documentation
	Reference to page
	Reference to graphic
	Result of an individual step

## 1.3 Symbols on the device

	Reference to device documentation
	Do not dispose of products bearing this marking as unsorted municipal waste. Instead, return them to the manufacturer for disposal under the applicable conditions.

## 1.4 Documentation

 Special Documentation for hygienic applications, SD02751C

## 2 Basic safety instructions

### 2.1 Requirements for the personnel

- Installation, commissioning, operation and maintenance of the measuring system may be carried out only by specially trained technical personnel.
- The technical personnel must be authorized by the plant operator to carry out the specified activities.
- The electrical connection may be performed only by an electrical technician.
- The technical personnel must have read and understood these Operating Instructions and must follow the instructions contained therein.
- Faults at the measuring point may only be rectified by authorized and specially trained personnel.

 Repairs not described in the Operating Instructions provided must be carried out only directly at the manufacturer's site or by the service organization.

### 2.2 Intended use

The Cleanfit CPA875 retractable assembly, which can be manually or pneumatically operated, is designed for the installation of sensors in vessels and pipes.

Thanks to its design, it can be operated in pressurized systems (→  67).

Any use other than that intended puts the safety of people and the measuring system at risk. Therefore, any other use is not permitted.

The manufacturer is not liable for harm caused by improper or unintended use.

#### 2.2.1 Use in explosion-proof areas

As a manufacturer of products used for analysis, we declare that the product supplied has undergone an ignition risk assessment and may be used in hazardous atmospheres once the following conditions for safe usage have been met:

- The protective ring is labeled as follows: "CAUTION, DANGER DUE TO ELECTROSTATIC CHARGES, CLEAN USING ONLY AN ANTISTATIC CLOTH". This instruction must be observed.
- Assemblies comprising wetted parts made of non-conductive material, must not be used in potentially explosive atmospheres.
- The compressed air supply, sensors and limit position switches must comply with the applicable guidelines and standards for use in hazardous atmospheres, be labeled with the degree of protection and meet the requirements of the relevant range of application. The ambient temperatures must be observed. The limit position switch used in the product complies with this requirement.
- Ensure that the compressed air does not contain a potentially explosive atmosphere.
- Please ensure that movements associated with the retraction and insertion of the sensor do not damage the connection.
- The product must be incorporated into the local potential equalization system.
- The Operating Instructions for the product and in particular the conditions for safe usage must be read, understood and implemented.

The product does not need to be labeled with the degree of protection.

### 2.3 Workplace safety

As the user, you are responsible for complying with the following safety conditions:

- Installation guidelines
- Local standards and regulations
- Regulations for explosion protection

## 2.4 Operational safety

### Before commissioning the entire measuring point:

1. Verify that all connections are correct.
2. Ensure that electrical cables and hose connections are undamaged.
3. Do not operate damaged products, and protect them against unintentional operation.
4. Label damaged products as defective.

### During operation:

- ▶ If faults cannot be rectified,  
take products out of service and protect them against unintentional operation.

## 2.5 Product security

### 2.5.1 State-of-the-art technology

The product is designed to meet state-of-the-art safety requirements, has been tested, and left the factory in a condition in which it is safe to operate. The relevant regulations and international standards have been observed.

## 3 Product description

### 3.1 Product design

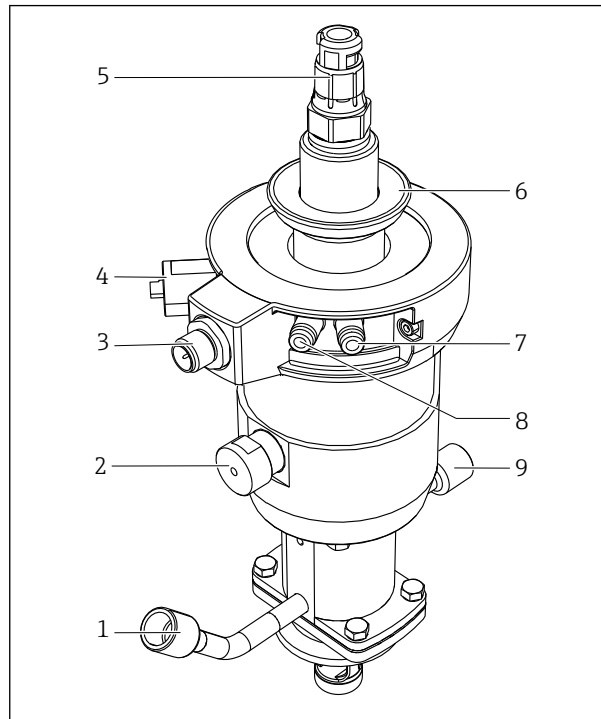

- 1 Rinse connection (inlet)
- 2 Automatic limit position lock, process
- 3 Connection for limit position switch
- 4 Automatic limit position lock, service
- 5 Sensor head
- 6 Fastening ring for cover
- 7 Pneumatic connection (move to measuring position)
- 8 Pneumatic connection (move to service position)
- 9 Rinse connection (outlet)

1 Assembly with pneumatic drive (without cover)

#### 3.1.1 Operating principle

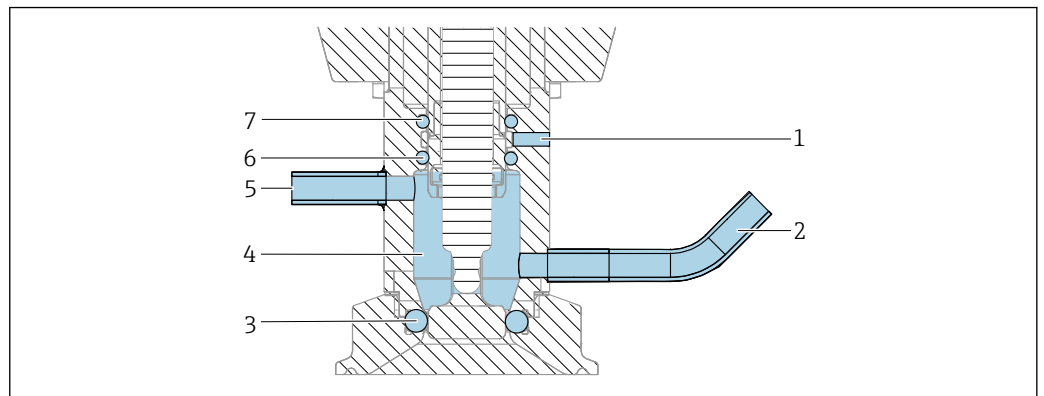

2 Sealing system, assembly in service position

- 1 Leakage hole
- 2 Rinse chamber, inlet
- 3 Process seal, seal for DN25 with 1 x O-ring
- 4 Rinse chamber
- 5 Rinse chamber, outlet
- 6 Seal, rinse chamber (1 x O-ring)
- 7 Seal drive (1 x O-ring)

## Process seal

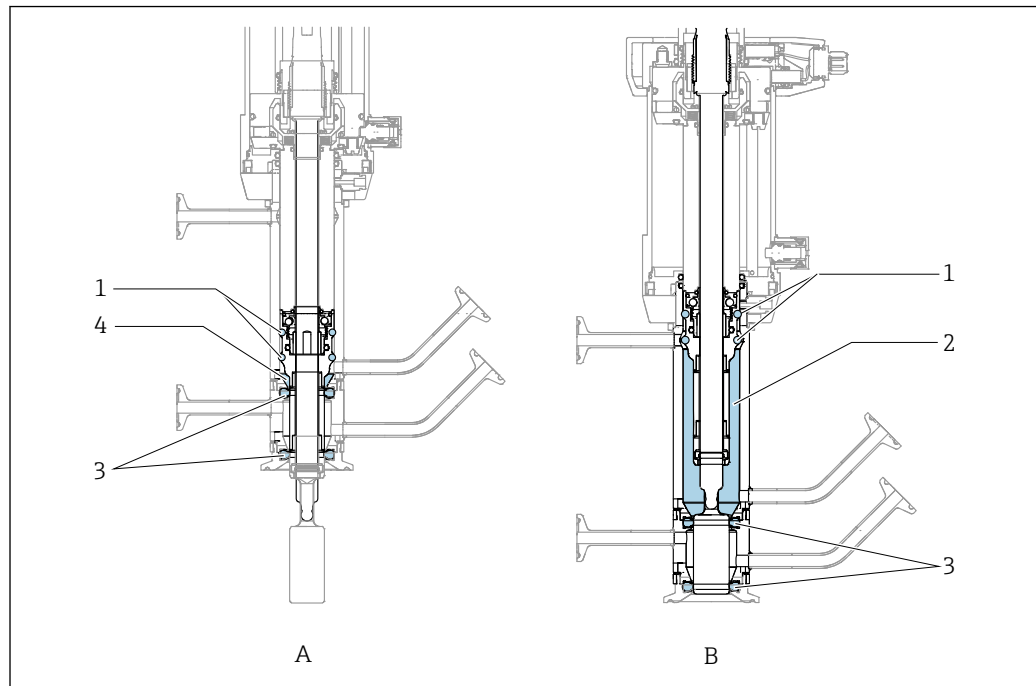

A0044088

3 Moving sealing rings, only refers to the double chamber

- A Measuring position
- B Service position
- 1 "Moving" seals in the double chamber
- 2 Chamber volume in service position
- 3 Molded seal
- 4 Chamber volume in measuring position



## 4 Incoming acceptance and product identification

### 4.1 Incoming acceptance

1. Verify that the packaging is undamaged.
  - ↳ Notify the supplier of any damage to the packaging.  
Keep the damaged packaging until the issue has been resolved.
2. Verify that the contents are undamaged.
  - ↳ Notify the supplier of any damage to the delivery contents.  
Keep the damaged goods until the issue has been resolved.
3. Check that the delivery is complete and nothing is missing.
  - ↳ Compare the shipping documents with your order.
4. Pack the product for storage and transportation in such a way that it is protected against impact and moisture.
  - ↳ The original packaging offers the best protection.  
Make sure to comply with the permitted ambient conditions.

If you have any questions, please contact your supplier or your local Sales Center.

### 4.2 Scope of delivery

The scope of delivery comprises:

- Assembly in the version ordered
- Operating Instructions
- Adapter for plug-in connector, 6 mm (0.24 in) to 4 mm (0.16 in) (outer diameter)
- Optional accessories ordered

## 4.3 Product identification

### 4.3.1 Nameplate

The nameplate provides you with the following information on your device:

- Manufacturer identification
- Order code
- Extended order code
- Serial number
- Ambient and process conditions
- Safety information and warnings

► Compare the information on the nameplate with the order.

### 4.3.2 Identifying the product

The order code and serial number of your product can be found in the following locations:

- On the nameplate
- In the delivery papers

#### Obtaining information on the product

1. Go to [www.endress.com](http://www.endress.com).
2. Page search (magnifying glass symbol): Enter valid serial number.
3. Search (magnifying glass).
  - ↳ The product structure is displayed in a popup window.
4. Click the product overview.
  - ↳ A new window opens. Here you fill information pertaining to your device, including the product documentation.

#### Product page

[www.endress.com/CPA875](http://www.endress.com/CPA875)

#### Manufacturer address

Endress+Hauser Conducta GmbH+Co. KG  
Dieselstraße 24  
70839 Gerlingen  
Germany

## 5 Mounting

### 5.1 Mounting requirements

#### 5.1.1 Information regarding hygiene-compliant installation according to EHEDG

Easily cleanable installation of equipment according to the criteria of the EHEDG must be free of dead legs. If a dead leg is unavoidable, it shall be kept as short as possible. Under no circumstances shall the length of a dead leg  $L$  exceed the pipe's inner diameter  $D$  minus the equipment's enveloping diameter  $d$ . The condition  $L \leq D - d$  applies. Furthermore, the dead leg must be self-draining, so neither product nor process fluids are retained therein. Within tank installations, the cleaning device must be located so that it directly flushes the dead leg.

For further reference, see the recommendations concerning hygienic seals and installations in EHEDG Doc. 10 and the Position Paper: "Easy cleanable Pipe couplings and Process connections".

#### 5.1.2 Information regarding hygiene-compliant installation according to 3-A

For 3-A-compliant installation, please observe the following:

1. After mounting the device, ensure its hygienic integrity. For this purpose, the assembly must be installed in such a way that the leakage holes are located at the lowest point on the device.
2. Use 3-A-compliant process connections.

The leakage paths serve as an indicator for damaged seals. If medium escapes at one of the leakage paths, the assembly must be serviced, the seals must be replaced and the assembly must be cleaned thoroughly.

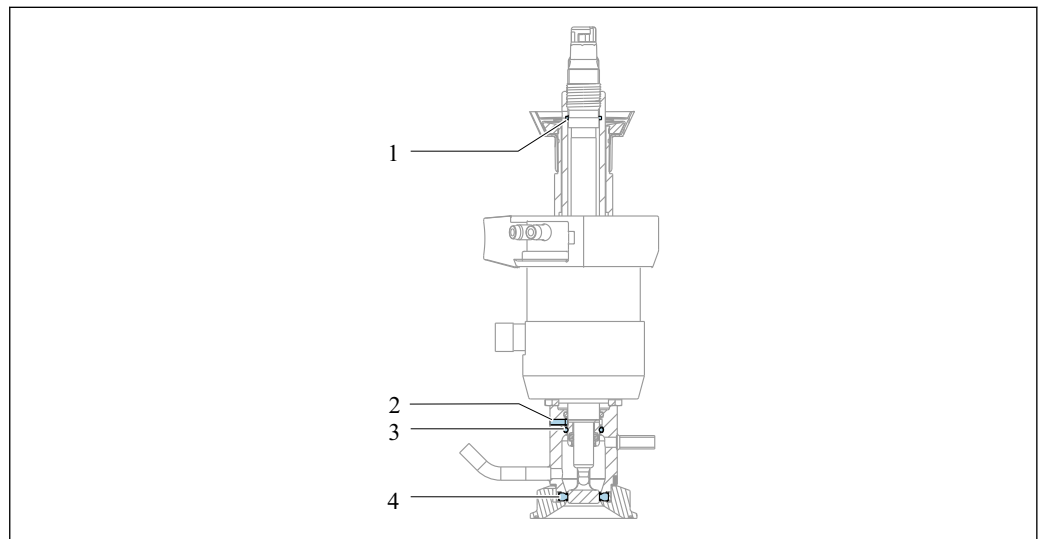

4 Hygienic bores and seals according to 3A

- 1 Bore, sensor screw-in
- 2 Bore, rinse chamber
- 3 Sensor seal
- 4 Process seal

Due to the operating principle, there is a connection between the process and the service chamber during insertion/retraction. This serves a number of purposes:

- Prevention of contamination of the process: due to the pressure in the process, small volumes of process medium are flushed into the service chamber, thereby preventing any negative interference with the process.
- Implementation of the sealing water function: in applications with media that cake easily, suitable media (e.g. condensate) can be flushed into the process to extend the service life of the seals.

1. Connect the rinsing chamber connections accordingly.
2. Include the assembly in the maintenance concept
3. Clean the assembly regularly.

### 5.1.3 Orientation

The assembly is designed for installation on vessels and pipes. Suitable process connections must be available for this.

#### NOTICE

##### Frost damage to the assembly

- ▶ If used outdoors, ensure that water cannot penetrate the drive.

The assembly is designed in such a way that there are no restrictions with regard to the orientation.

- i** The sensor that is used can restrict the orientation.

The assembly can be installed in a way that it is self-draining.

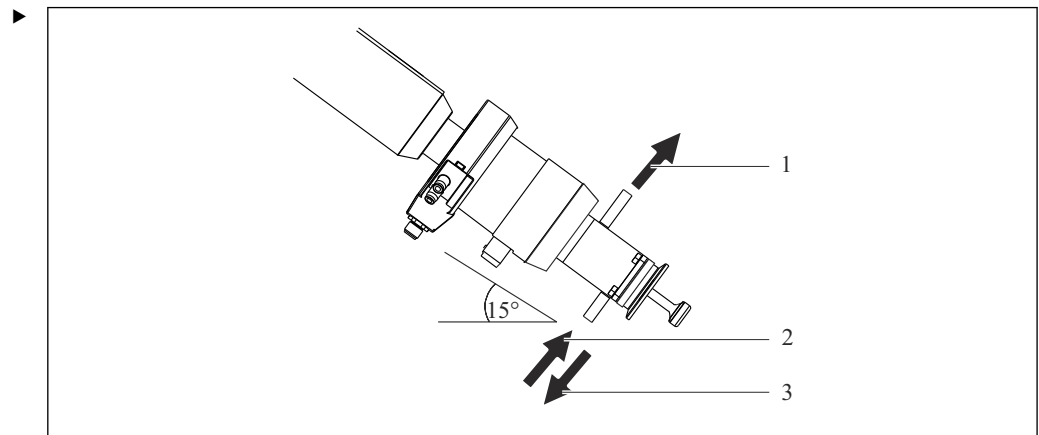

**5** Installation angle for self-draining

- 1 Rinse
- 2 Rinse
- 3 Drain

Install the assembly at an angle of 0° to 15° in relation to the horizontal.

- ↳ The service chambers are now self-draining.

- i** Ensure compliance with the Operating Instructions of the sensor installed.

### 5.1.4 Dimensions

#### Short version

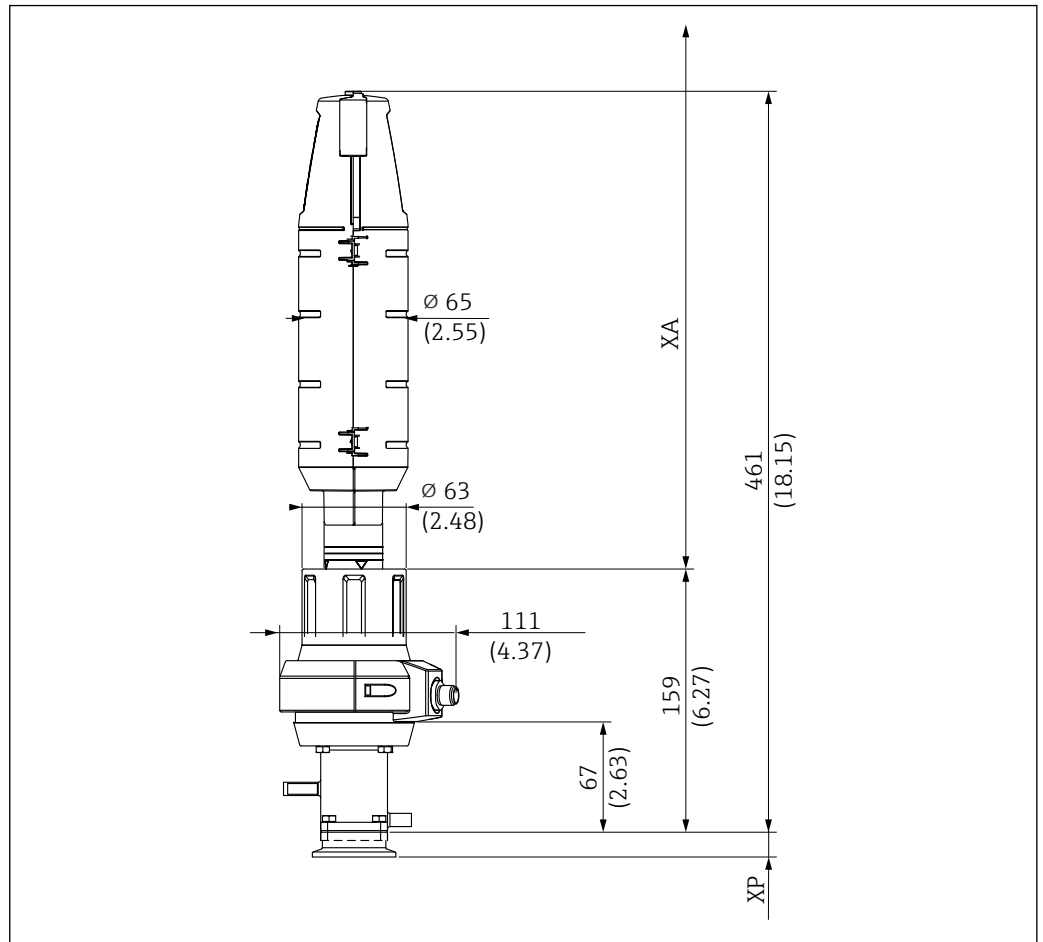

6 Dimensions for short version (36 mm stroke) with manual drive in service position in mm (in)

XP Height of particular process connection (see table below)

XA Necessary mounting distance for sensor replacement = 425 mm (16.73")

A0047412

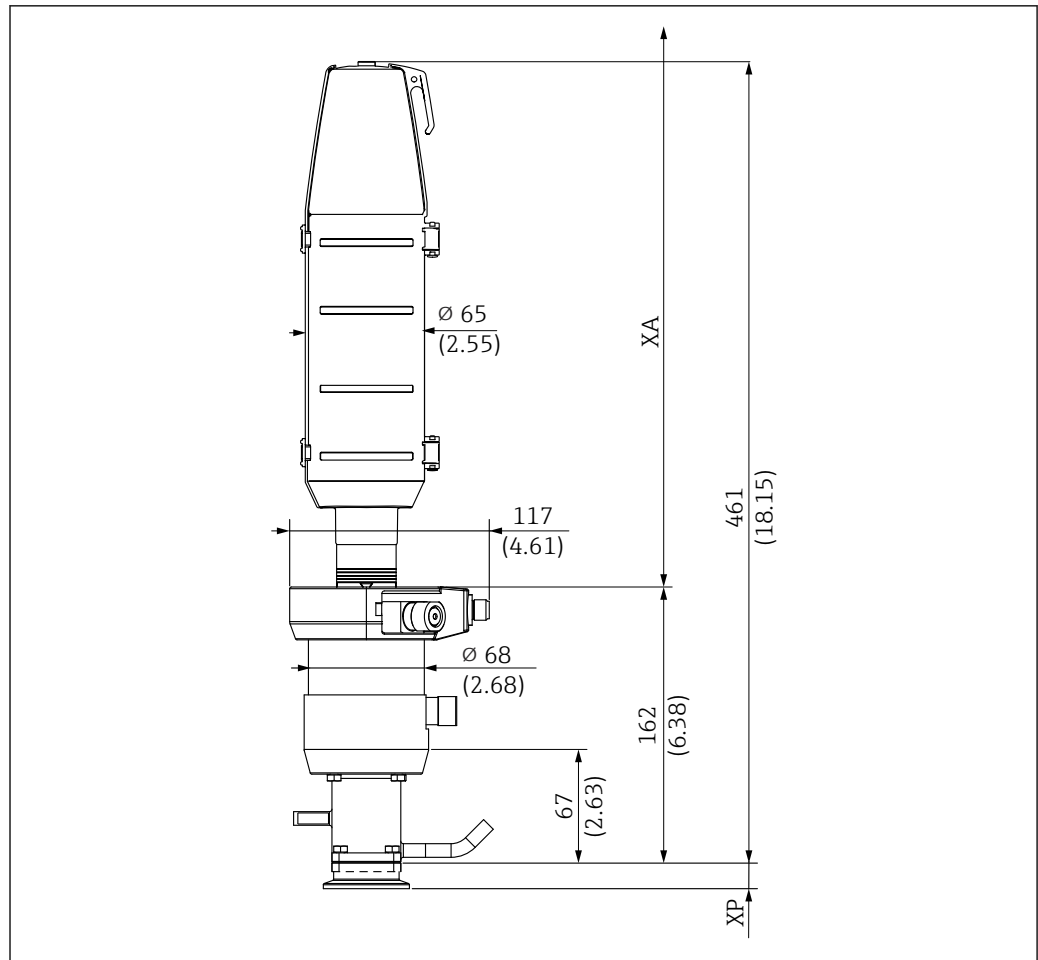

A0047413

7 Dimensions for short version (36 mm stroke) with pneumatic drive in service position in mm (in)

XP Height of particular process connection (see table below)

XA Necessary mounting distance for sensor replacement = 425 mm (16.73")

## Long version

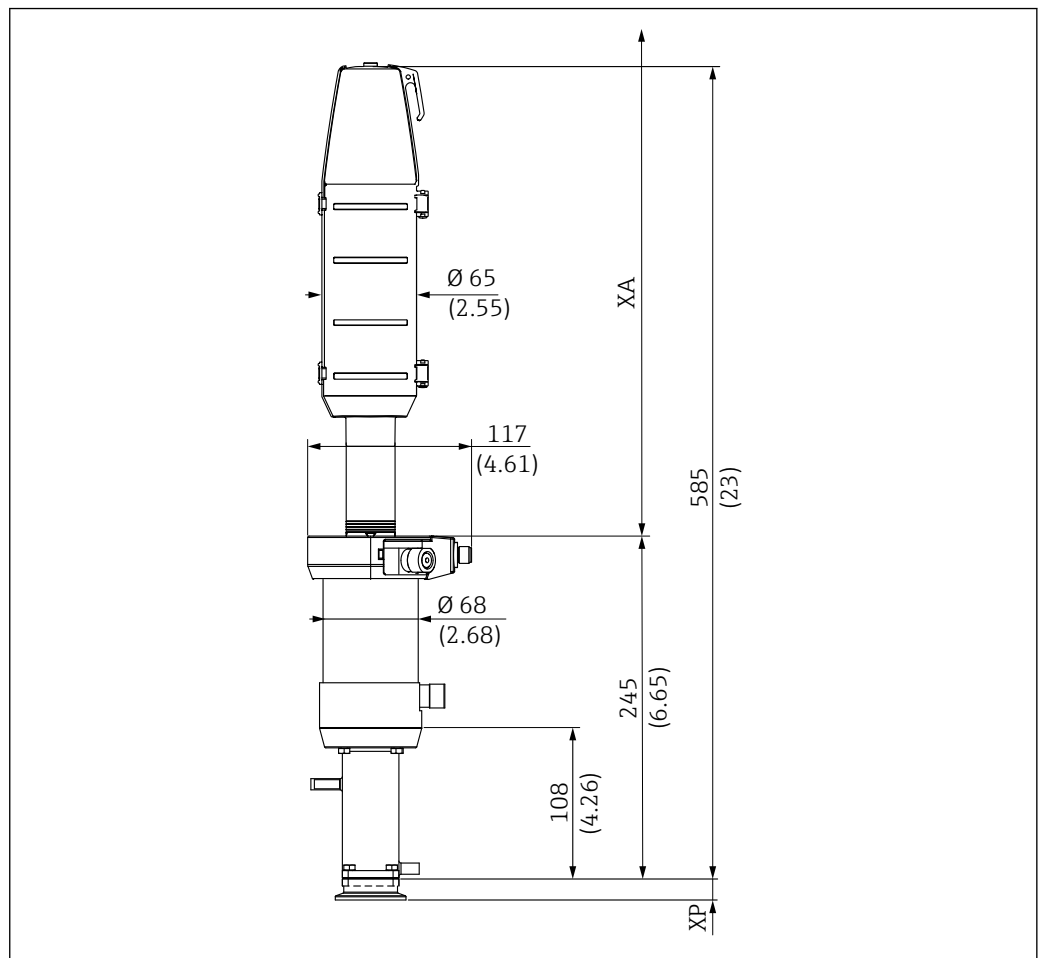

A0047411

8 Dimensions for long version (78 mm stroke) with pneumatic drive in service position in mm (in)

XP Height of particular process connection (see table below)

XA Necessary mounting distance for sensor replacement

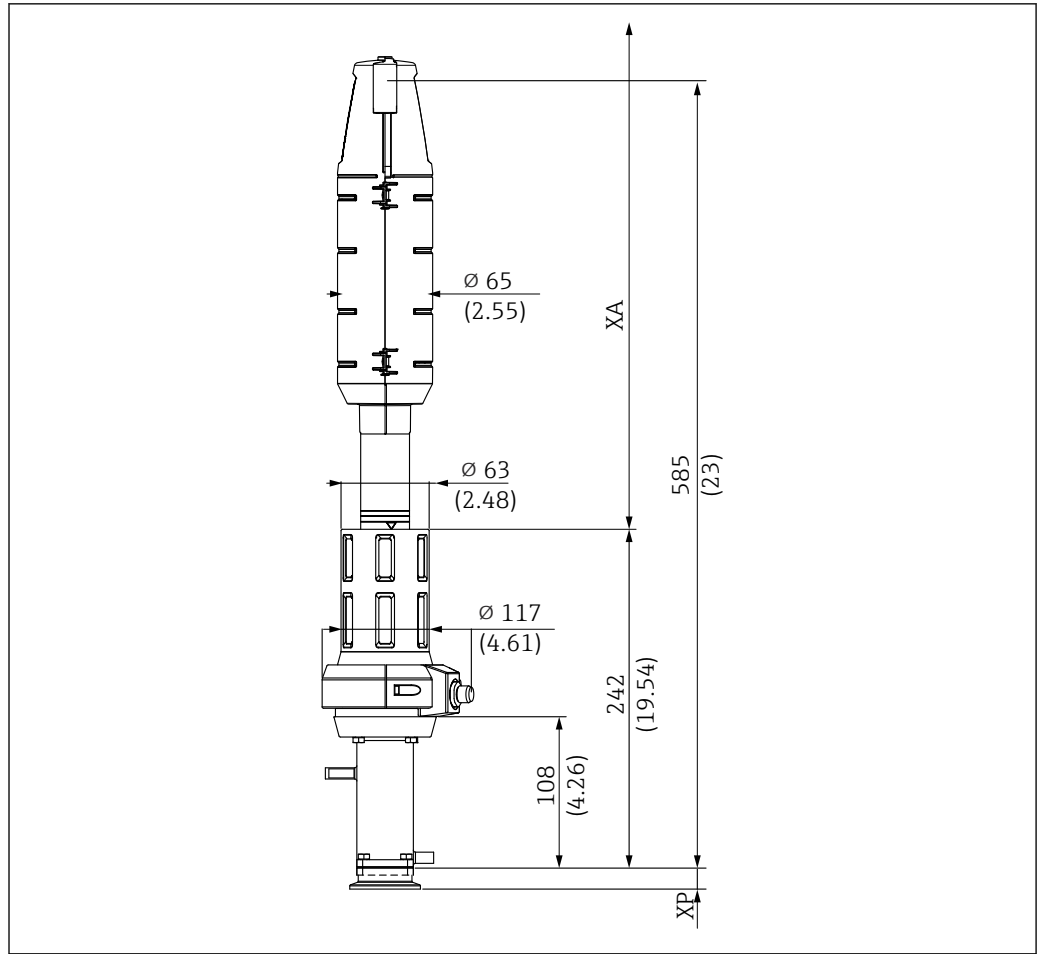

A0047416

9 Dimensions for long version (78 mm stroke) with manual drive in service position in mm (in)

XP Height of particular process connection (see table below)

XA Necessary mounting distance for sensor replacement

A free path length XA above the drive is required to replace the sensors:

XA is 440 mm (17.32") for 225 mm sensors

XA is 610 mm (24.02") for 360 mm sensors

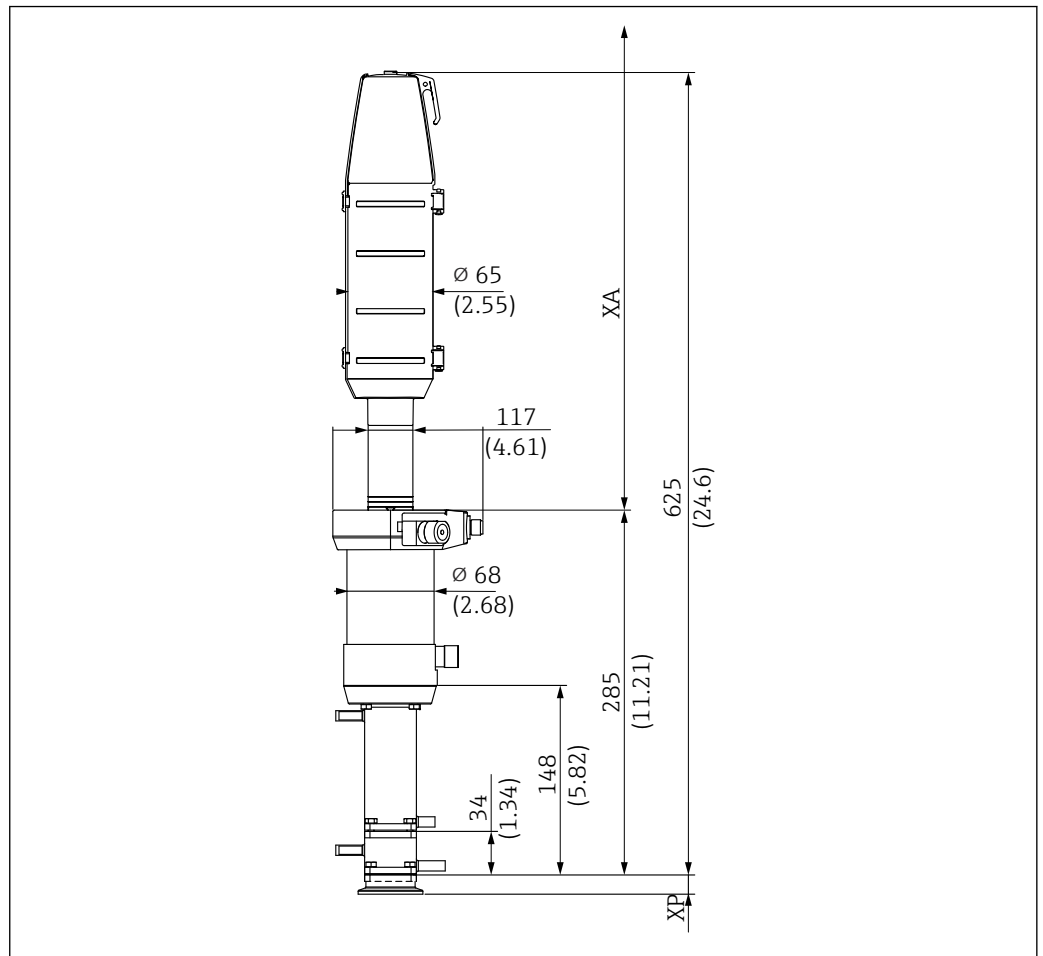

*Double chamber*

A0047414

10 Dimensions of double chamber in mm (in)

XP Height of particular process connection (see table below)







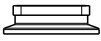

XA Necessary mounting distance for sensor replacement

A free path length XA above the drive is required to replace the sensors:

XA is 440 mm (17.32") for 225 mm sensors

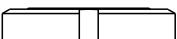
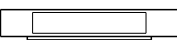
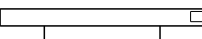
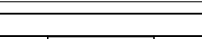
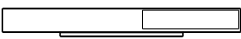
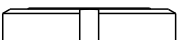
XA is 610 mm (24.02") for 360 mm sensors

**Process connection height**

Process connection		Height XP in mm (in)
<b>CA</b> Clamp ISO 2852, ASME BPE-2012, 1½"	 A0021866	14.9 (0.59)
<b>CB</b> Clamp ISO 2852, ASME BPE-2012, 2"	 A0021867	19.5 (0.77)
<b>CC</b> Clamp ISO 2852, ASME BPE-2012, 2½"	 A0021869	13.0 (0.51)
<b>DA</b> Aseptic DN 25 clamp-on DIN 11864-3 A, grooved clamp (NKS)	 A0021871	16.0 (0.63)
<b>DC</b> Aseptic DN 50 screw-in DIN 11864-1 A	 A0021872	16.0 (0.63)
<b>DF</b> Aseptic DN 50 grooved flange DIN 11864-2 A	 A0021874	14.2 (0.56)
<b>EA</b> Neumo BioControl D 65	 A0021875	25.0 (0.98)
<b>EB</b> Neumo BioConnect D 50	 A0021877	10.5 (0.41)
<b>EF</b> Neumo BioConnect D 65	 A0021876	10.5 (0.41)
<b>MA</b> Dairy fitting DN 50 DIN 11851 (EHEDG approval only with seal from Siersema)	 A0021879	14.5 (0.57)
<b>MB</b> Dairy fitting DN 65 DIN 11851 (EHEDG approval only with seal from Siersema)	 A0021878	13.8 (0.54)
<b>NA</b> Thread ISO 228 G1¼	 A0043131	31.1 (1.22)
<b>VA</b> Varivent flange N (DN 40 to 100)	 A0021873	19.0 (0.75)

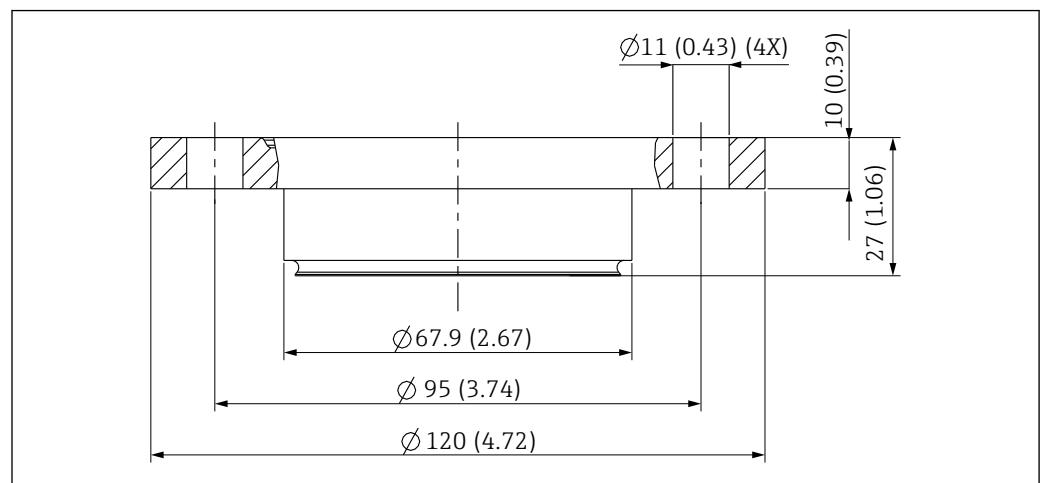

11 Dimensions of EA Neumo BioControl D 65 in mm (in)

A0046172

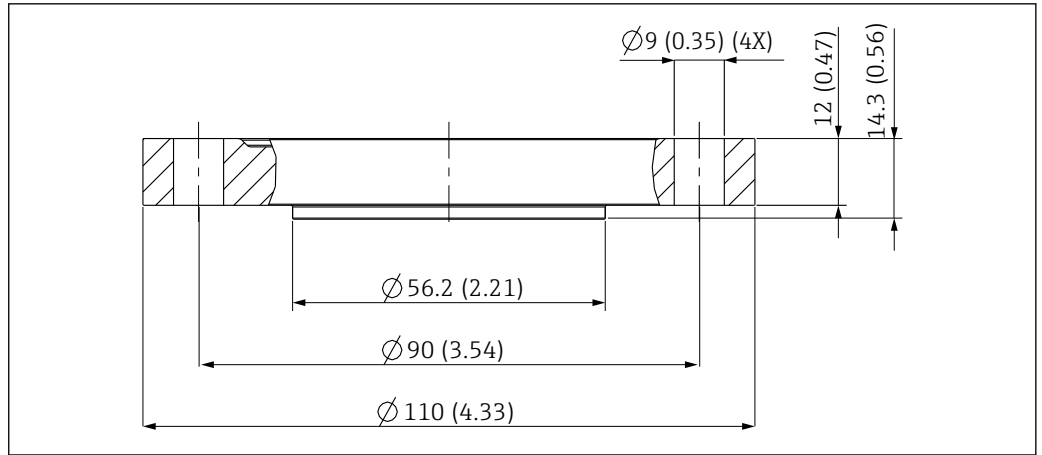

A0046170

12 Dimensions of EB Neumo BioConnect D 50 in mm (in)

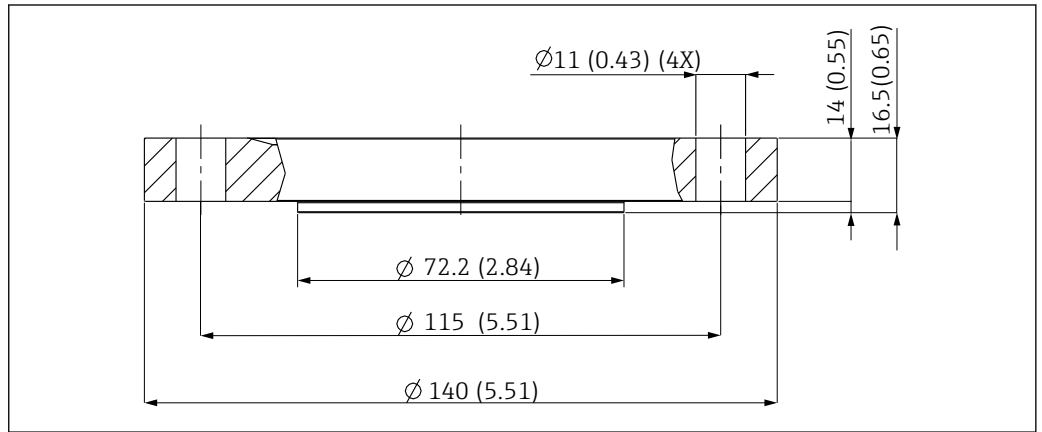

A0046173

13 Dimensions of EF Neumo BioConnect D 65 in mm (in)

### 5.1.5 Immersion depths

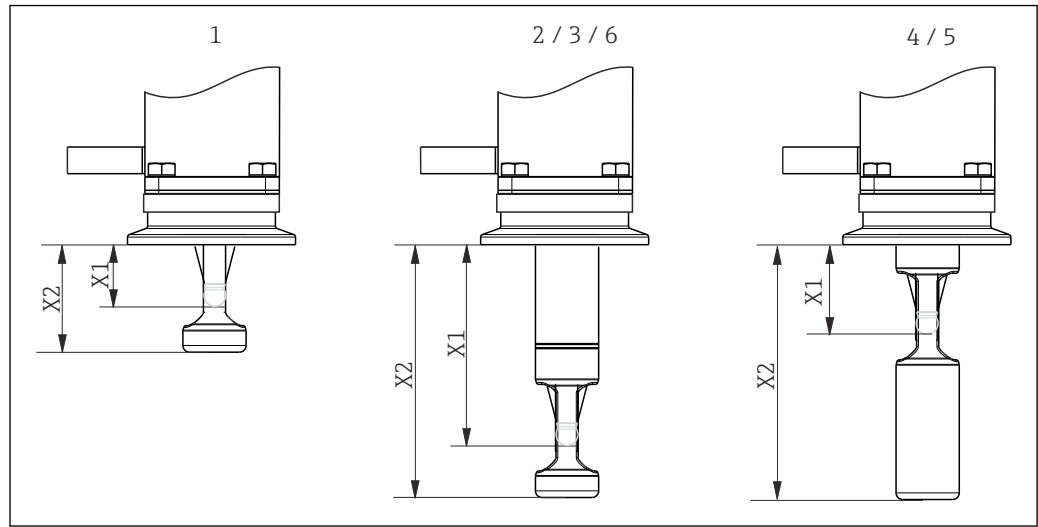

A0017745

14 Immersion depths for different service chambers

- 1 Single chamber/36 mm stroke/225 mm sensor incl. KCI
- 2 Single chamber/ 78 mm stroke / 225 mm sensor excl. KCI
- 3 Single chamber/78 mm stroke/360 mm sensor incl. KCI
- 4 Double chamber / 78 mm stroke / sensor 225 mm excl. KCI / service position, "inner" service chamber
- 5 Double chamber/78 mm stroke/360 mm sensor incl. KCI/service position, "inner" service chamber
- 6 Double chamber/78 mm stroke/360 mm sensor incl. KCI/service position, "front" service chamber

Immersion depths in mm (inch)

Process connection		Service chamber					
		1	2	3	4	5	6
CA Clamp ISO2852 ASME BPE-2012 1½"	X1	20.6 (0.81)	62.1 (2.44)	62.1 (2.44)	28.1 (1.11)	28.1 (1.11)	62.1 (2.44)
	X2	31.6 (1.24)	73.1 (2.88)	73.1 (2.88)	73.1 (2.88)	73.1 (2.88)	73.1 (2.88)
CB Clamp ISO2852 ASME BPE-2012 2"	X1	16.1 (0.63)	57.6 (2.27)	57.6 (2.27)	23.6 (0.93)	23.6 (0.93)	57.6 (2.27)
	X2	27.1 (1.07)	68.6 (2.70)	68.6 (2.70)	68.6 (2.70)	68.6 (2.70)	68.6 (2.70)
CC Clamp ISO2852 ASME BPE-2012 2½"	X1	22.6 (0.89)	64.1 (2.52)	64.1 (2.52)	30.1 (1.19)	30.1 (1.19)	64.1 (2.52)
	X2	33.6 (1.32)	75.1 (2.96)	75.1 (2.96)	75.1 (2.96)	75.1 (2.96)	75.1 (2.96)
DA Aseptic DN 25 clamp-on DIN11864-3 A	X1	19.6 (0.77)	61.1 (2.41)	61.1 (2.41)	27.1 (1.07)	27.1 (1.07)	61.1 (2.41)
	X2	30.6 (1.20)	72.1 (2.84)	72.1 (2.84)	72.1 (2.84)	72.1 (2.84)	72.1 (2.84)
DC Aseptic DN 50 screw-in DIN11864-1 A	X1	27.1 (1.07)	68.6 (2.70)	68.6 (2.70)	34.6 (1.36)	34.6 (1.36)	68.6 (2.70)
	X2	39.0 (1.53)	79.6 (3.13)	79.6 (3.13)	79.6 (3.13)	79.6 (3.13)	79.6 (3.13)
DF Aseptic DN 50 Grooved flange DIN11864-2 A	X1	21.4 (0.84)	62.9 (2.48)	62.9 (2.48)	28.9 (1.14)	28.9 (1.14)	62.9 (2.48)
	X2	32.4 (1.28)	73.9 (2.91)	73.9 (2.91)	73.9 (2.91)	73.9 (2.91)	73.9 (2.91)
EA Neumo Biocontrol D65	X1	27.6 (1.09)	69.1 (2.72)	69.1 (2.72)	35.1 (1.38)	35.1 (1.38)	69.1 (2.72)
	X2	38.5 (1.51)	80.1 (3.15)	80.1 (3.15)	80.1 (3.15)	80.1 (3.15)	80.1 (3.15)
EB Neumo Bioconnect D50	X1	22.6 (0.89)	64.1 (2.52)	64.1 (2.52)	30.1 (1.19)	30.1 (1.19)	64.1 (2.52)
	X2	33.6 (1.32)	75.1 (2.96)	75.1 (2.96)	75.1 (2.96)	75.1 (2.96)	75.1 (2.96)
EF Neumo Bioconnect D65	X1	20.6 (0.81)	62.1 (2.44)	62.1 (2.44)	28.1 (1.11)	28.1 (1.11)	62.1 (2.44)
	X2	31.6 (1.24)	73.1 (2.88)	73.1 (2.88)	73.1 (2.88)	73.1 (2.88)	73.1 (2.88)
MA Dairy fitting DN 50 DIN11851	X1	21.1 (0.83)	62.6 (2.46)	62.6 (2.46)	28.6 (1.13)	28.6 (1.13)	62.6 (2.46)
	X2	32.1 (1.26)	73.6 (2.90)	73.6 (2.90)	73.6 (2.90)	73.6 (2.90)	73.6 (2.90)
MB Dairy fitting DN 65 DIN11851	X1	21.8 (0.86)	63.3 (2.49)	63.3 (2.49)	29.3 (1.16)	29.3 (1.16)	63.3 (2.49)
	X2	32.8 (1.29)	74.3 (2.93)	74.3 (2.93)	74.3 (2.93)	74.3 (2.93)	74.3 (2.93)
NA thread ISO228 G 1¼	X1		70.4 (2.77)	70.4 (2.77)			
	X2		81.4 (3.20)	81.4 (3.20)			
VA Varivent flange N (DN 40 to DN 100)	X1	16.6 (0.65)	58.1 (2.29)	58.1 (2.29)	24.1 (0.95)	24.1 (0.95)	58.1 (2.29)
	X2	27.6 (1.09)	69.1 (2.72)	69.1 (2.72)	69.1 (2.72)	69.1 (2.72)	69.1 (2.72)

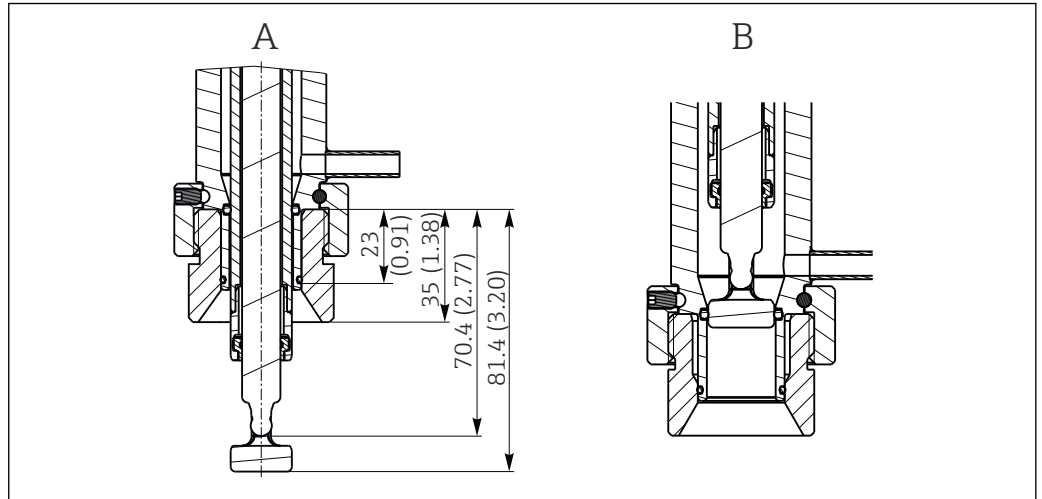

A0022162

15 Immersion depth in mm (in) for process connection NA thread ISO228 G1¼ (service chamber 2 and 3) in measuring and service position, mounted on weld-in adapter G1¼"

- A Measuring position
- B Service position

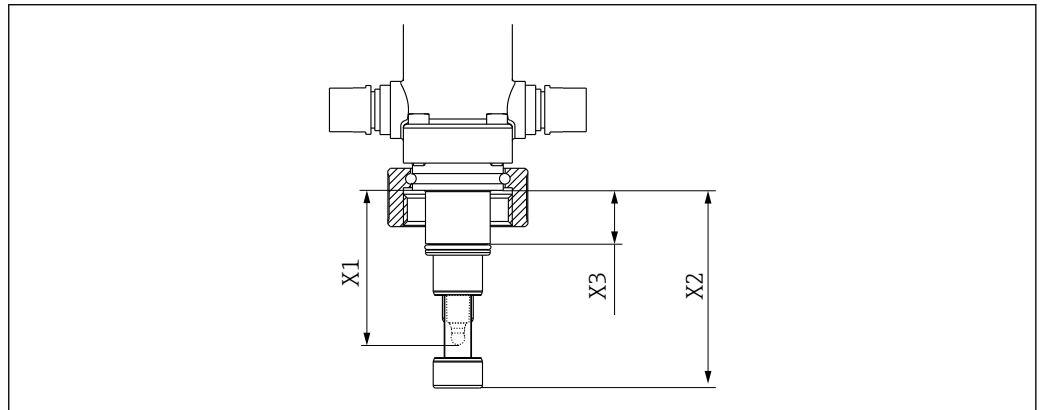

A0039342

16 Immersion depth in mm (in) for process connection NA thread ISO 228 G1¼

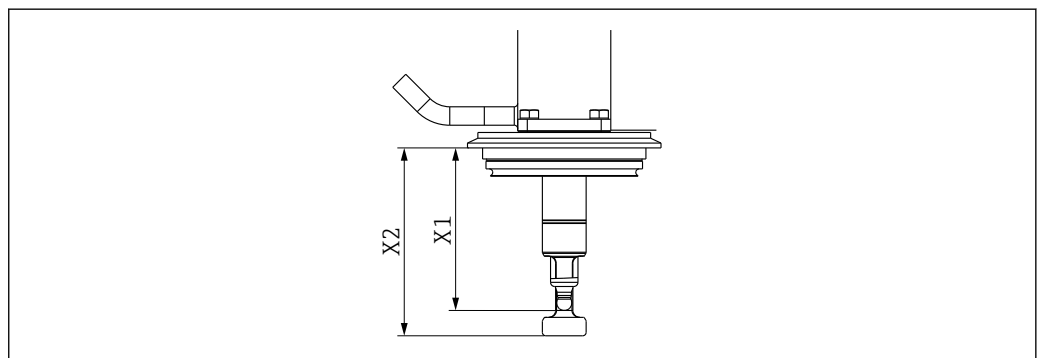

A0046162

17 Immersion depth in mm (in) for process connection VA thread

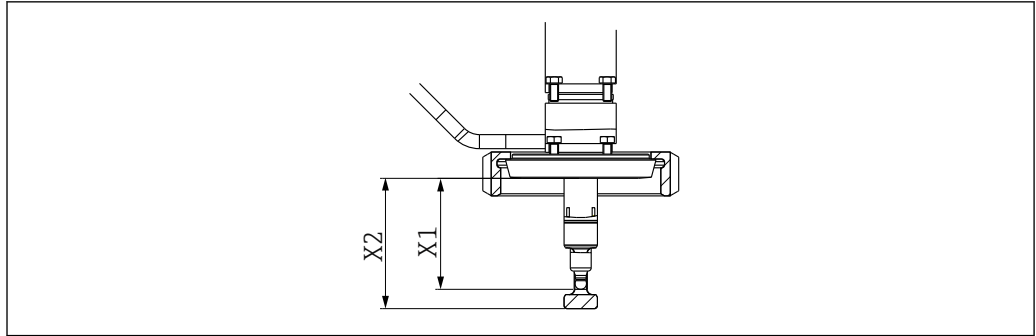

A0046161

18 Immersion depth in mm (in) for process connection MB thread

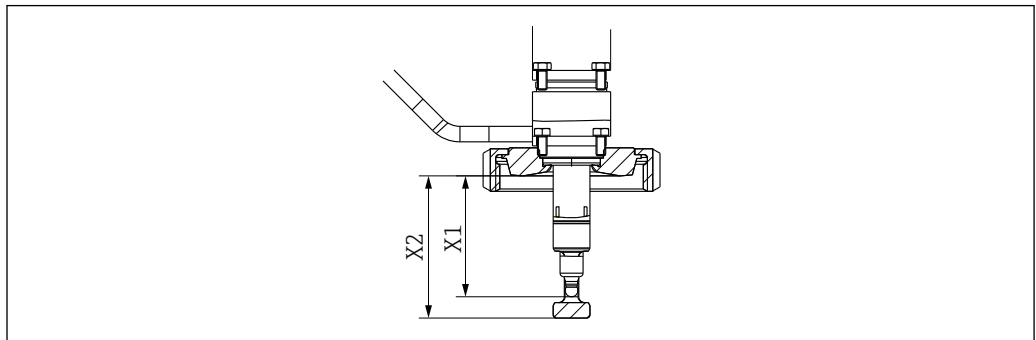

A0046160

19 Immersion depth in mm (in) for process connection MA thread

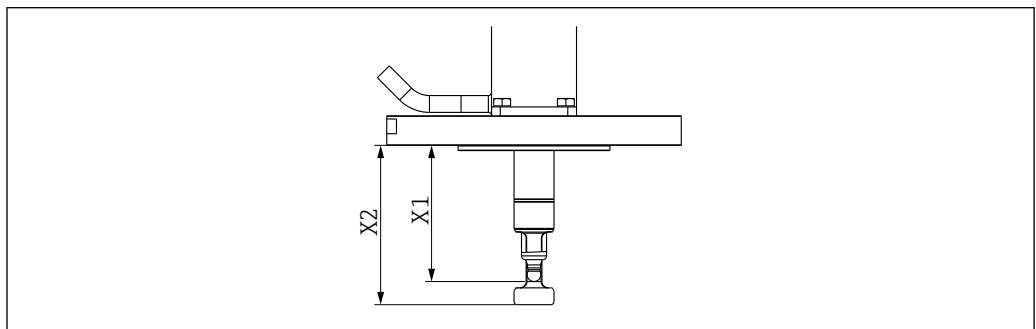

A0046159

20 Immersion depth in mm (in) for process connection EF thread

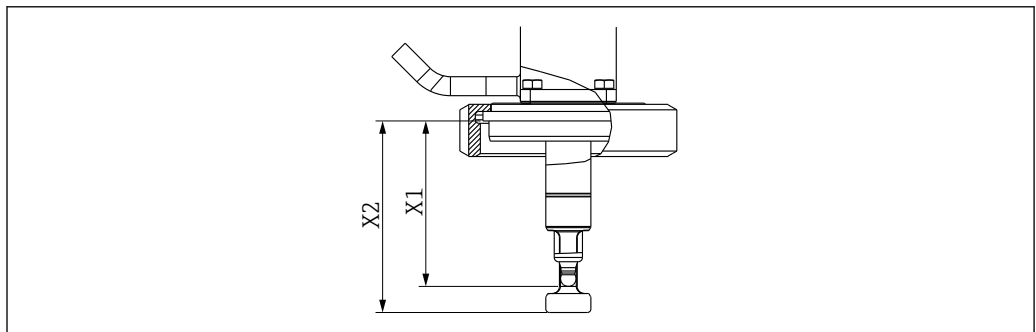

A0046156

21 Immersion depth in mm (in) for process connection DC thread

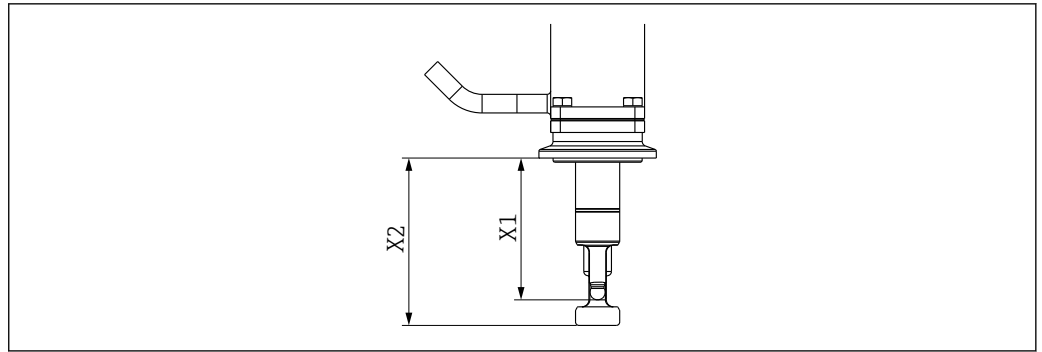

A0046155

22 Immersion depth in mm (in) for process connection DA thread

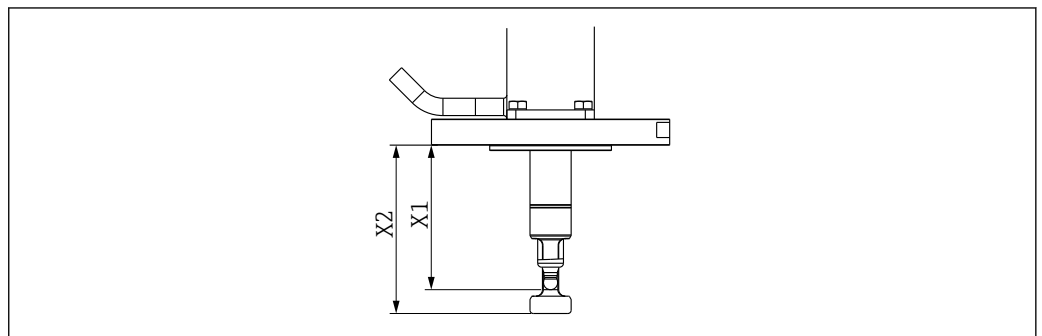

A0046158

23 Immersion depth in mm (in) for process connection EB thread

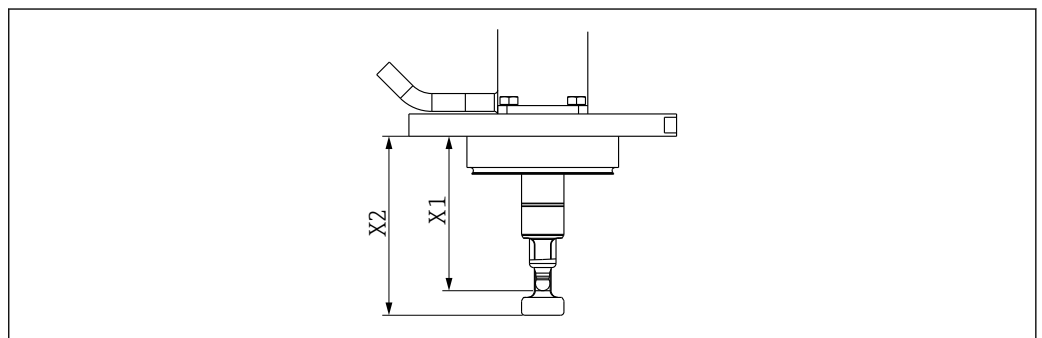

A0046157

24 Immersion depth in mm (in) for process connection EA thread

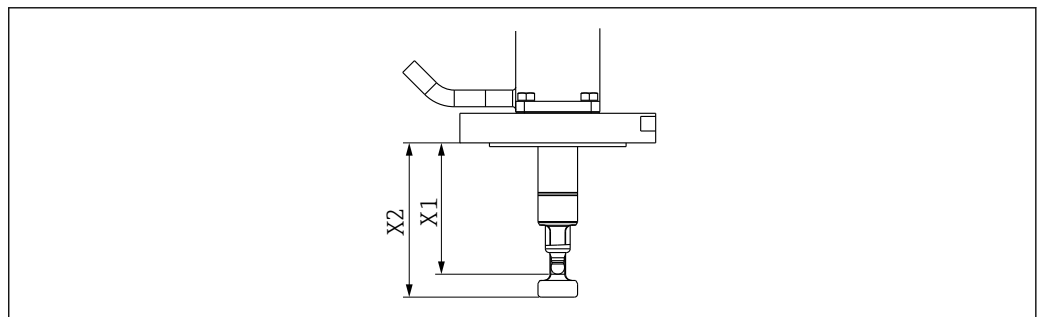

A0046166

25 Immersion depth in mm (in) for process connection DF thread

## 5.2 Mounting the assembly

### 5.2.1 Installation

#### Measuring system with single chamber

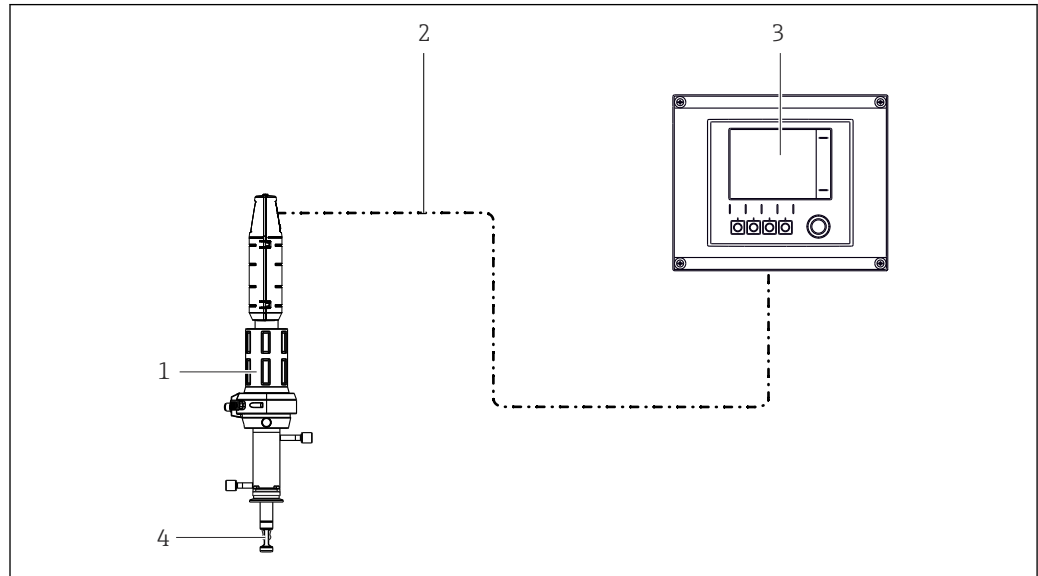

A0017811

26 Measuring system (example)

- 1 Assembly Cleanfit CPA875
- 2 Measuring cable
- 3 Transmitter Liquiline CM44x
- 4 Sensor



### Measuring system with double chamber

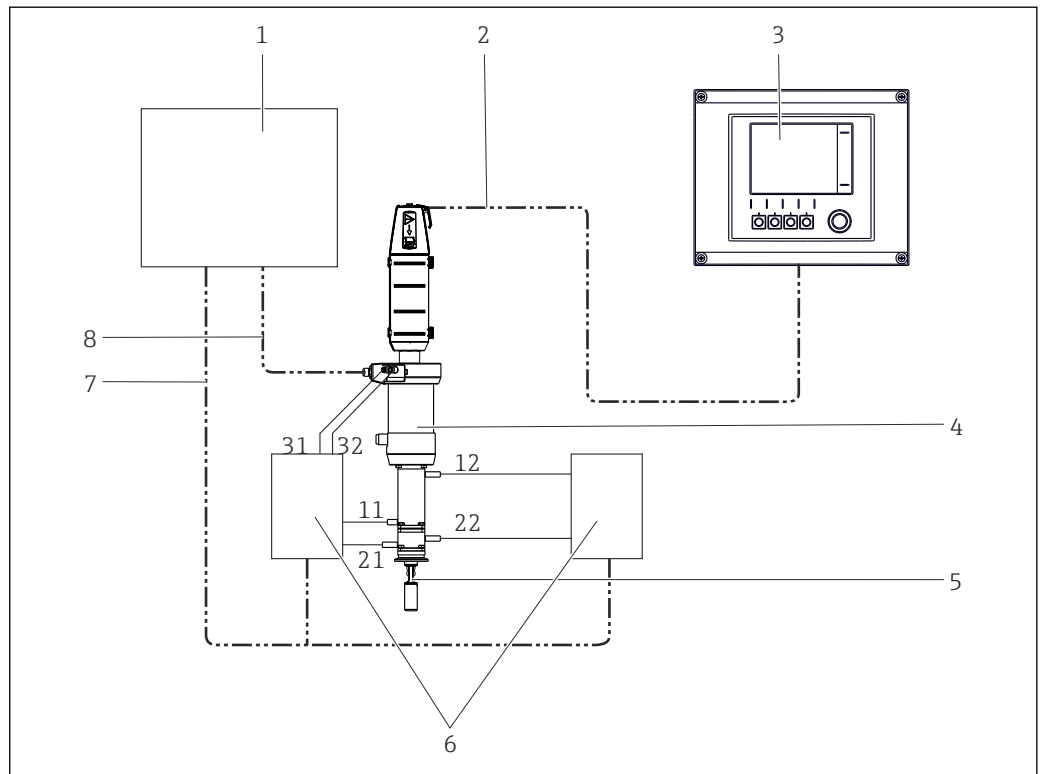

A0022821

#### 27 Measuring system with pneumatic drive and double chamber (example)

- |   |                             |       |   |
|---|-----------------------------|-------|---|
| 1 | Control unit                | 7     | Control signals (electric/pneumatic)    |
| 2 | Measuring cable             | 8     | Limit position switch relay signal      |
| 3 | Transmitter Liquiline CM44x | 11/12 | Inlet/outlet of "inner" service chamber |
| 4 | Assembly Cleanfit CPA875    | 21/22 | Inlet/outlet of "front" service chamber |
| 5 | Sensor                      | 31/32 | Drive control                           |
| 6 | Manifold                    |       |   |

#### Installation recommendation

The process seal seals the process in the end position. The assembly is open to the process during insertion/retraction; the rinse connections must either be pipe-fitted or sealed.

- i** The connection between the service chamber and the process is open during movement; the sealing water function can be used as a result. The rinse chamber outlet must be blocked (e.g., with a shutoff valve) to implement the sealing water function.

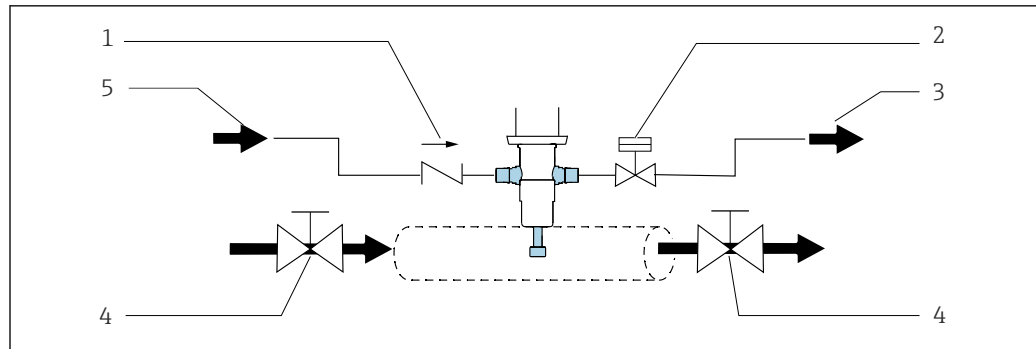

A0039105

28 Example of a sealing system via a bypass.

- 1 Check valve
- 2 Valve open/closed, sealing water function
- 3 Wastewater
- 4 Shut-off valve open/closed (optional)
- 5 Water/cleaning agent

The seals must be checked and serviced regularly. Therefore measures must be taken to separate the assembly from the process, e.g., by installing a bypass.

#### NOTICE

**There is a connection between the process and the service chamber during insertion/retraction.**

Contamination of the assembly.

- ▶ Include the assembly in the cleaning concept.
- ▶ Ensure regular cleaning.

### Installing/removing the assembly from the process

#### **⚠ WARNING**

**Risk of injury from high pressure, high temperature or chemical hazards if process medium escapes.**

- ▶ Wear protective gloves, protective goggles and protective clothing.
- ▶ Mount the assembly only if vessels or pipes are empty and unpressurized.

**i** Prior to installation, check the flange seal between the flanges.

1. Move the assembly to the service position.  
↳ (The triangle position marking is visible (→  29)).
2. Secure the assembly on the tank or piping via the process connection.
3. Follow the instructions in the next section to connect pipes for compressed air and rinse water (for the relevant assembly version).

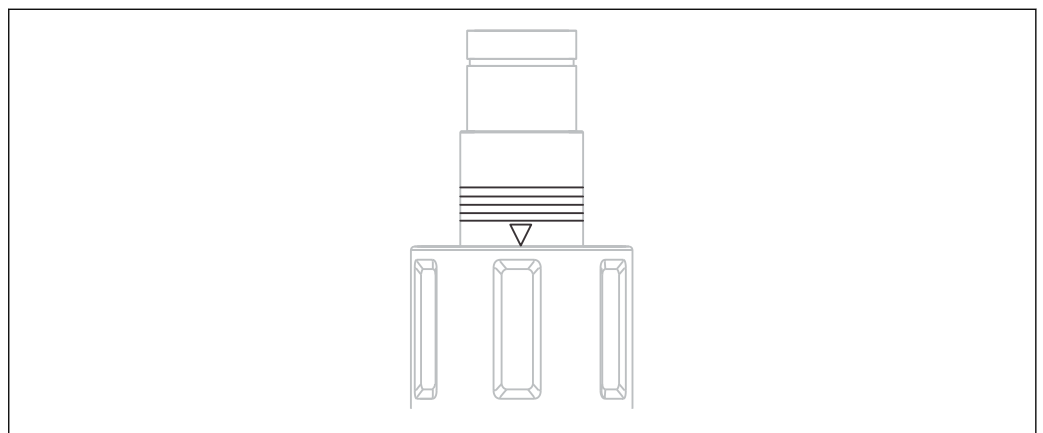

A0023307

 29 Position markings (service position)

### Pneumatic connection for automatic operation

Prerequisites:

- Air pressure 5 to 8 bar (absolute pressure) (72 to 116 psi) or air pressure 4 to 7 bar (gauge pressure) (58 to 102 psi)
- Compressed air quality in accordance with ISO 8573-1:2001 Quality class 3.3.3 or 3.4.3
- Solids class 3 (max. 5 µm, max. 5 mg/m<sup>3</sup>, contamination with particles)
- Water content for temperatures ≥ 15 °C: Class 4 pressure condensation point 3 °C or lower
- Water content for temperatures of 5 to 15 °C: Class 3 pressure condensation point -20 °C or lower
- Oil content: Class 3 (max. 1 mg/m<sup>3</sup>)
- Air temperature: 5 °C or higher
- No continuous air consumption
- Minimum nominal diameter of air pipes: 2 mm (0.08 ")

Connection: Plug-in connector M5, hose 4/2 mm OD/ID (adapter for 6/4 mm OD/ID enclosed)

#### NOTICE

#### Air pressure too high

Damage to seals.

- ▶ Connect a pressure-reducing valve upstream if the air pressure is likely to rise to above 7 bar (absolute pressure) (102 psi) (even short pressure surges).

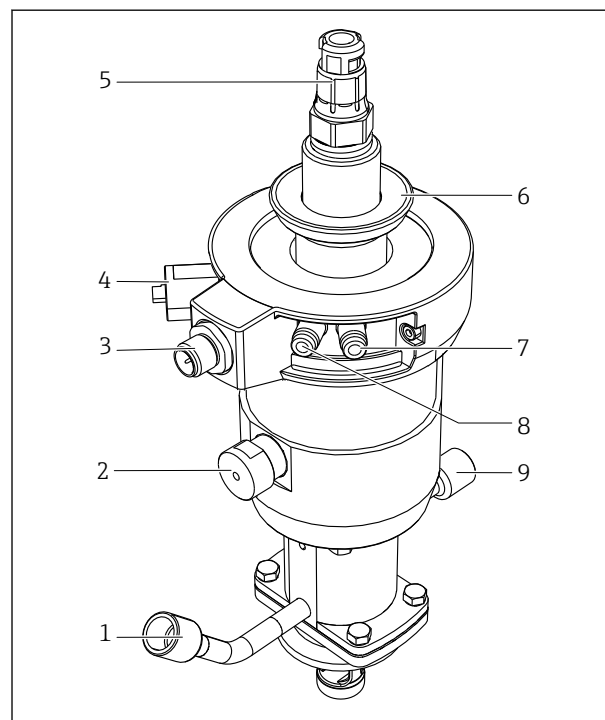

- 1 Rinse connection (inlet)
- 2 Automatic limit position lock, process
- 3 Connection for limit position switch
- 4 Automatic limit position lock, service
- 5 Sensor head
- 6 Fastening ring for cover
- 7 Pneumatic connection (move to measuring position)
- 8 Pneumatic connection (move to service position)
- 9 Rinse connection (outlet)

30 Assembly with pneumatic drive (without cover)

- i** Use a pneumatic pilot valve (4/2-way or 5/2-way) to insert/retract the assembly. Connect the two inputs of the assembly.

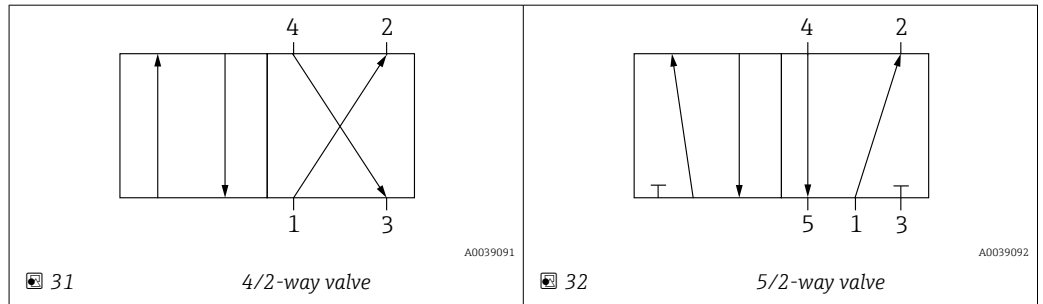

Connection 1 is attached to the compressed air supply.

Connections 2 and 4 are used to attach to the pneumatic drive.

Connection 3 and, if present, connection 5 are not attached; they are used to vent the drive.

### Rinse connections

The service chamber connections of the sterile CPA875 retractable assembly make it possible to rinse the chamber (including the sensor) with water or cleaning solution or to sterilize it with steam (SIP) at a maximum pressure of 6 bar (87 psi).

The retractable assembly can be selected with a single-chamber system or double-chamber system. If the double-chamber system is used, all four connections must be connected to inlet and outlet lines.

**i** Install a pressure-reducing valve upstream if there is the possibility that water pressures can exceed the specified sealing water pressure (8 bar (116 psi) or 16 bar (232 psi)).

### NOTICE

**Pressure difference too high between process and wastewater system or if rinse connections are not properly connected.**

Damage to seals

- ▶ Close rinse connections.
- ▶ Pipe-fit rinse connections.
- ▶ Use sealing water function.

### Assignment of rinse connections for double chamber

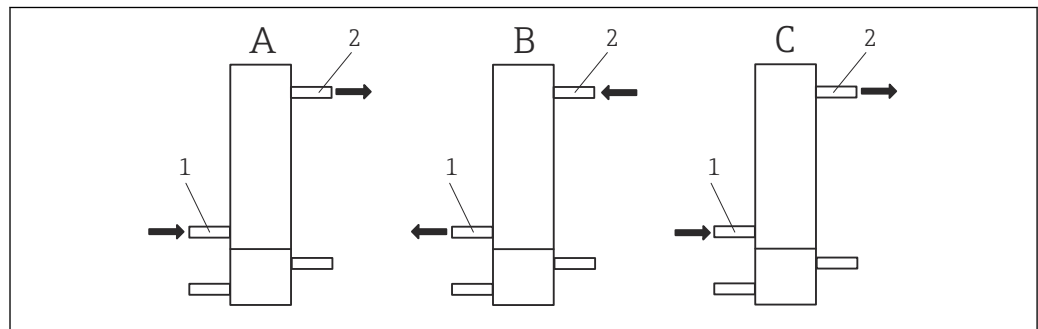

**33** Assignment of rinse inlet and outlet

A "Clean" function: connection and water/cleaner flow direction

B Aeration/de-aeration when moving from the service position to the measuring position

C Aeration/de-aeration when moving from the measuring position to the service position

1 Service chamber inlet

2 Service chamber outlet

In the "Cleaning" state (A), the inlet and outlet of the "inner" service chamber are used as follows (the internal volume of the "front" service chamber does not change, and so no pressure compensation measures are required here):

- Depending on the cleaning method, cleaning agent and purge gas are supplied via the inlet (1).
- These media are removed via the outlet (2).

In the "Move from service position to measuring position" state (B), the pressure conditions in the service chamber must be balanced when moving. The inlet and outlet of the service chamber are assigned as follows:

- The air is removed via the inlet (1) (inlet is open).
- Air is supplied via the outlet (2).

In the "Move from measuring position to service position" state (C), the pressure conditions in the service chamber must be balanced when moving. The inlet and outlet of the service chamber are assigned as follows:

- The air is supplied via the inlet (1).
- The air is removed via the outlet (2) (outlet is open).

**i** The drive must be controlled simultaneously with the control of the inlets and outlets of the "inner service chamber".

The controller for the inlets, outlets and the drive is installed at the place of installation. It is not included in the assembly delivery.

### Assignment of rinse connections for single chamber

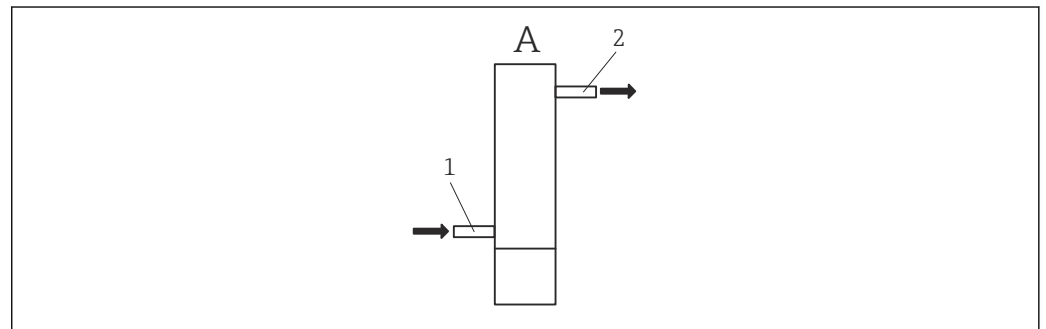

**34** Connection and water/cleaner flow direction

- A "Clean" function: connection and water/cleaner flow direction  
 1 Service chamber inlet  
 2 Service chamber outlet

In the "Cleaning" state (A), the inlet and outlet of the service chamber are used as follows (the internal volume of the service chamber does not change, and so no pressure compensation measures are required here):

- Depending on the cleaning method, cleaning agent is supplied via the inlet (1).
- These media are removed via the outlet (2).

### Connecting the limit position switches

With limit position detection, you can notify a system located downstream (transmitter, switching amplifier, output interface terminal) whether the assembly is in the measuring or service position (in the case of manual drive, only the measuring position is queried).

The limit position switches must be connected to output interface terminals (can be ordered as accessories for the non-hazardous area) to enable power supply.

The assembly can be ordered directly with limit position detection, or it can be retrofitted at a later stage. The cable for the limit position switches must be ordered as an accessory.

### Feedback devices

The feedback devices are intrinsically safe. The approval for the feedback devices is no longer valid if they are not installed or connected correctly.

1. Ensure full compliance with manufacturer documentation.
2. Connect the feedback devices in accordance with the relevant instructions.

Switching element function:	NAMUR NC contact (inductive)
Switching distance:	1.5 mm (0.06 ")
Nominal voltage:	8 V DC
Switching frequency:	0 to 5000 Hz
Housing material:	Stainless steel

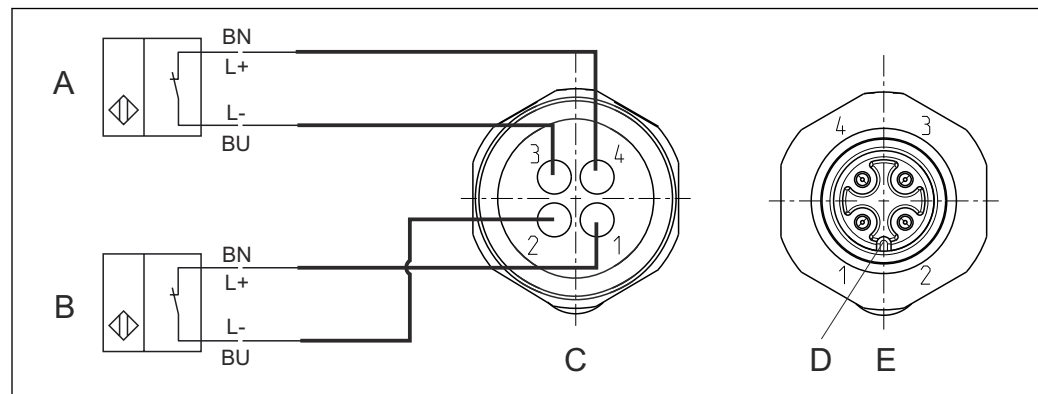

A0017831

35 Inductive limit position switches, internal wiring in the blue protective ring

- A Limit position switch, service position
- B Limit position switch, measuring position
- C Connector, M12, solder side (inside of assembly)
- D Coding
- E Connector, pin side (outside of assembly)



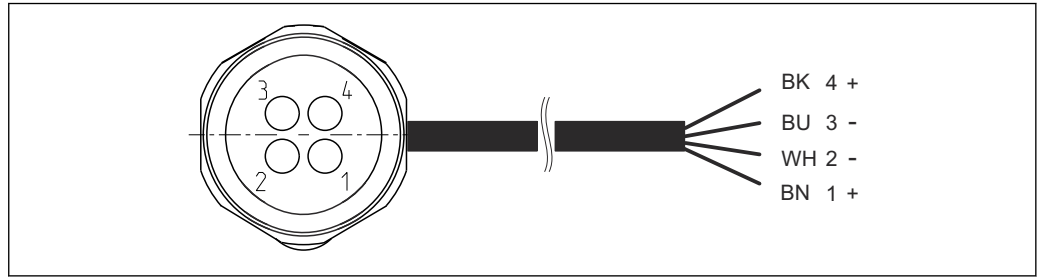

A0022163

36 Connecting cable for limit position switch on transmitter, switching amplifier, output interface terminal etc.

- 1 Measuring position
- 2 Measuring position
- 3 Service position
- 4 Service position

**i** Only pins 1 and 2 are assigned for manually activated assemblies with one switch (measuring position).

**i** If the feedback devices are operated with a 24 V DC power supply, e.g. at Liquiline CM442/CM444/CM448, NAMUR terminals must be used. Namur terminal (8 V DC) for the non-hazardous area available as an accessory → 60. The Namur terminal must have its own power supply and cannot be powered by a current output of the CM44.

**i** For versions CPA87x-AB\* for use in hazardous areas, the enclosed manufacturer's declaration and the operating instructions for the installed Pepperl+Fuchs NJ1.5-6.5-15-N-Y180094 feedback devices must be observed.

Signal table for limit position switches

Position of assembly	Limit position switch, measuring position	Limit position switch, service position
Measuring	Active LOW ( $\geq 3$ mA)	Active LOW ( $\geq 3$ mA)
Service	Active HIGH ( $\leq 1$ mA)	Active HIGH ( $\leq 1$ mA)

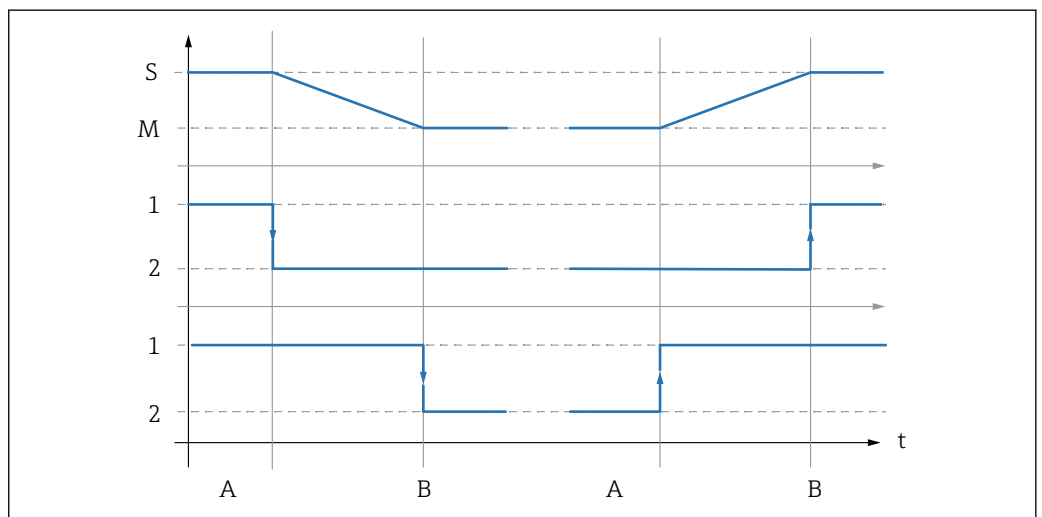

A0039144

37 Description of switching function

- S Service
- M Measuring
- 1 High
- 2 Low
- A Movement starts
- B Limit position reached

## 5.2.2 Sensor installation

### Preparing the sensor and assembly

#### NOTICE

**Danger of medium penetrating if a defective sensor is installed.**

- ▶ Inspect the sensor and use a new, intact sensor if necessary.

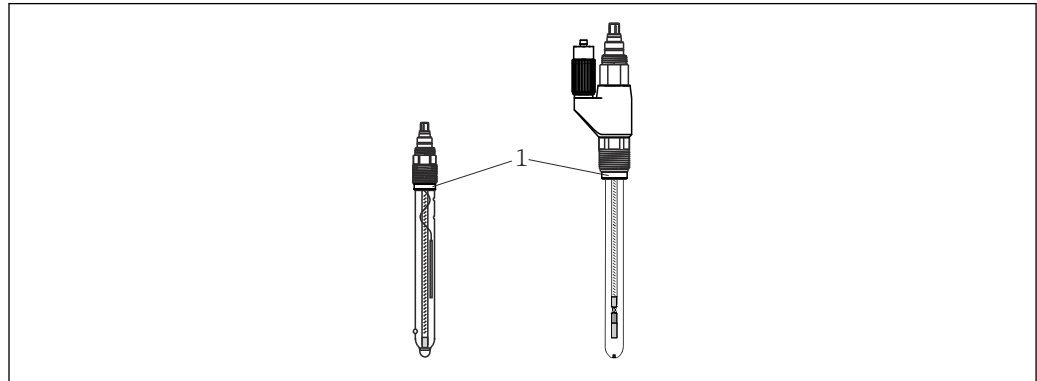

A0030154

☞ 38 Sensor installation

1 Thrust collar with O-ring

1. Remove protective cap from sensor. Make sure that the O-ring and thrust collar (→ ☞ 38, item 1) are provided.
2. To aid installation, immerse the sensor shaft in water.
3. Move the assembly to the service position.

### 3-A versions

Leak path at sensor screw-in on 3-A versions:

- ▶ Replace the thrust collar of the sensor with the slotted thrust collar enclosed.

### Installing and removing sensors

#### ⚠ WARNING

**Risk resulting from temperature, pressure and chemical composition!**

- ▶ Establish pressure compensation in the service chamber.
- ▶ Before removing, clean and rinse the sensor adequately in the rinse chamber.
- ▶ Check process seals. (There can be no leakage of medium from the rinse chamber in limit position when rinsing is disabled)

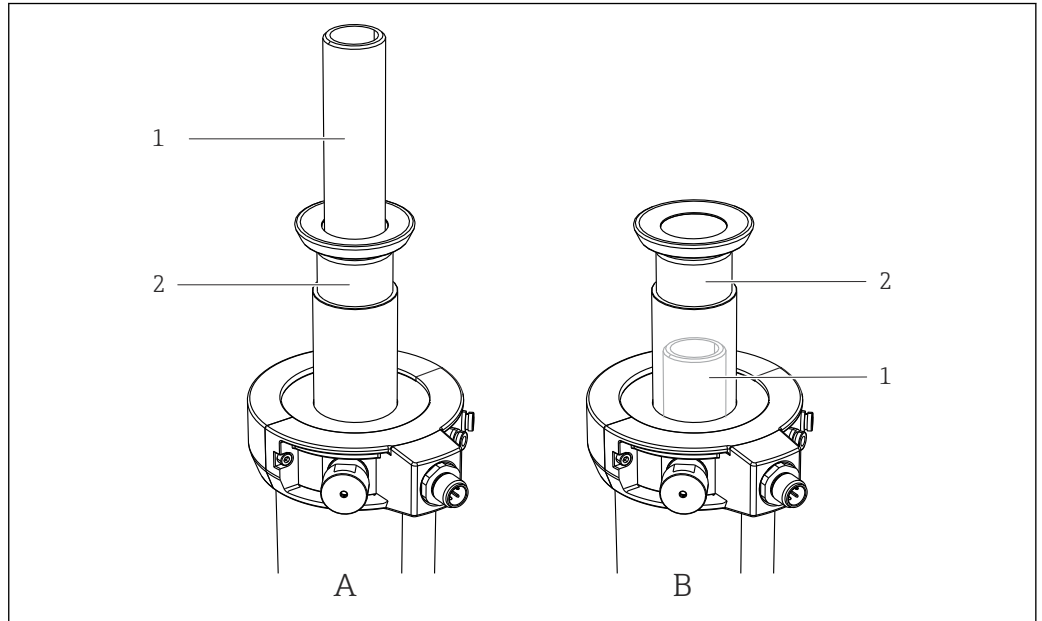

A0030155

39 Sensor installation options

- 1 Sensor adapter
- 2 Retraction pipe
- A Sensor adapter is on top of the retraction pipe
- B Sensor adapter is below the retraction pipe (not visible)

Depending on the assembly version, the sensor adapter is visible (, item A) or is positioned within the retraction pipe and is not visible (item B). As a result, the procedures for installing and removing the sensors differ as follows:

*Installing and removing sensors if the sensor adapter is visible (item A)*

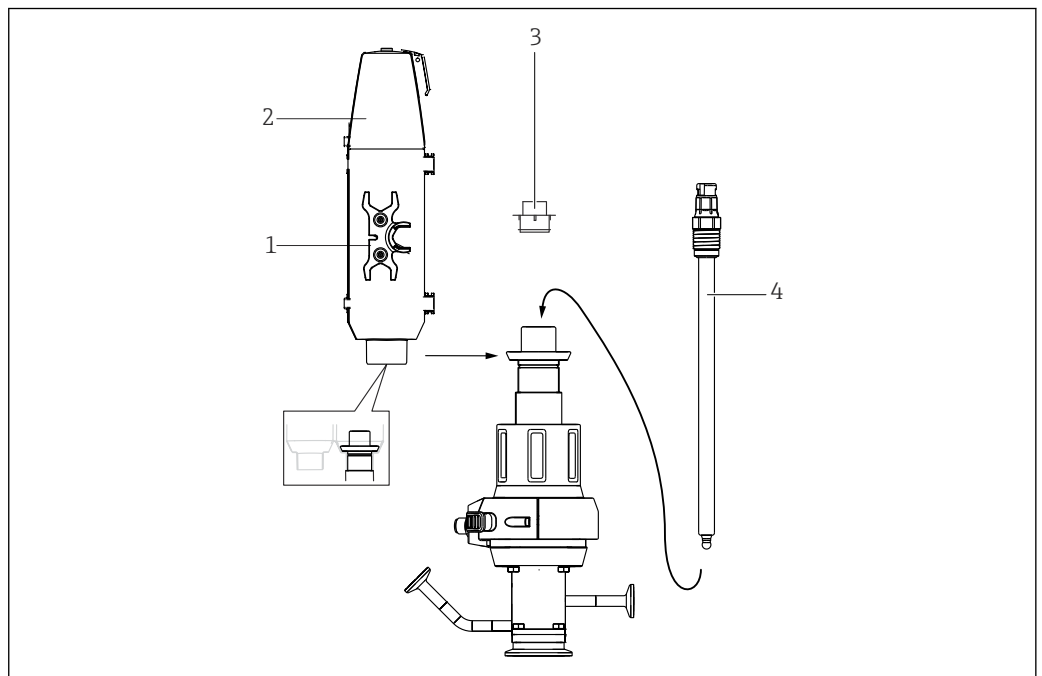

A0030186

40 Sensor installation

- 1 Open-ended wrench (AF 17/19 mm)
- 2 Cover
- 3 Dummy plug
- 4 Sensor

**i** Gel and KCl sensors can be installed in this version.

Install the sensor as follows:

1. Remove the cover (→  40, item 2) (only possible if the assembly is in the service position).
2. Remove the yellow dummy plug (item 3).
3. Use the open-ended wrench (item 1) to screw in the sensor (item 4) in place of the dummy plug and hand-tighten (3 Nm (2.2 lbf ft)).
4. Secure the open-ended wrench back in the cover.
5. Mount the cover on the assembly. When doing so, guide the measuring cable through the cable grommet (top of cover).

 Always mount the cover before you move the assembly to the measuring position. The cover cannot be removed in the measuring position and therefore prevents the removal of the sensor.

*Installing and removing sensors if the sensor adapter is not visible (item B)*

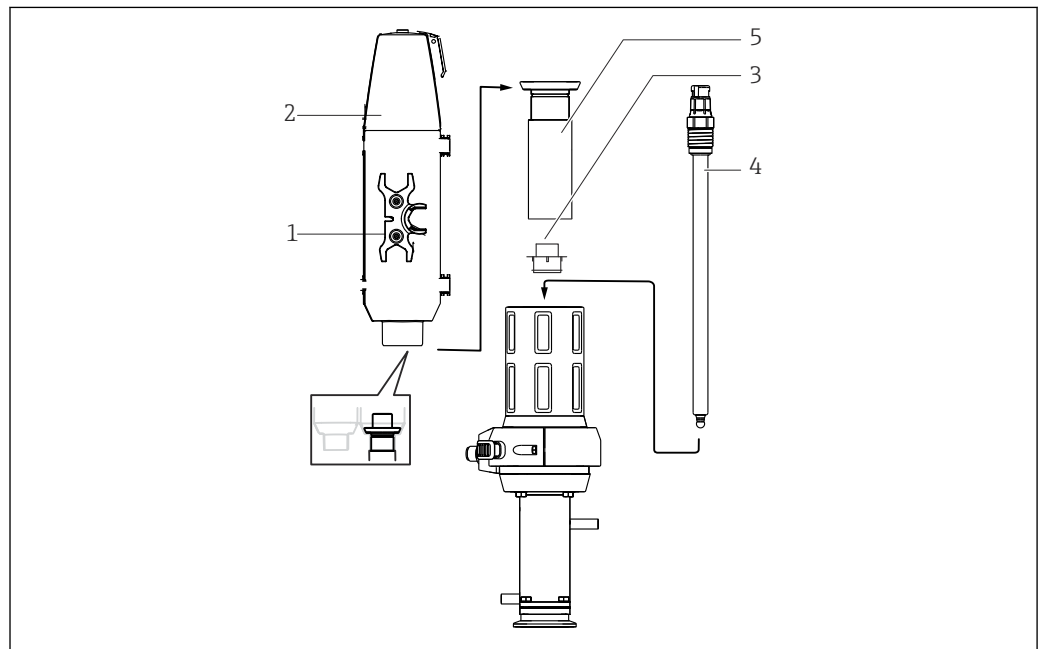

A0030187

 41 Sensor installation

- 1 Socket wrench (AF 17/19 mm)
- 2 Cover
- 3 Dummy plug (protective cap)
- 4 Sensor
- 5 Retraction pipe

 Gel sensors can be installed in this version. To install KCl sensors, you will need a "Gel - KCl adapter".

Install the sensor as follows:

1. Remove the cover (→  41, item 2) (only possible if the assembly is in the service position).
2. Unscrew the retraction pipe (item 5) in a counterclockwise direction.
3. Remove the yellow dummy plug (item 3).
4. Use the open-ended wrench (item 1) to screw in the sensor (item 4) in place of the dummy plug and hand-tighten (3 Nm (2.2 lbf ft)).
5. Screw in the retraction pipe again.
6. Secure the open-ended wrench back in the cover.

7. Mount the cover on the assembly. When doing so, guide the measuring cable through the cable grommet (top of cover).
- i** Always mount the cover before you move the assembly to the measuring position. The cover cannot be removed in the measuring position and therefore prevents the removal of the sensor.

#### Installing 360 mm gel and KCl sensors with "Gel - KCl adapter"

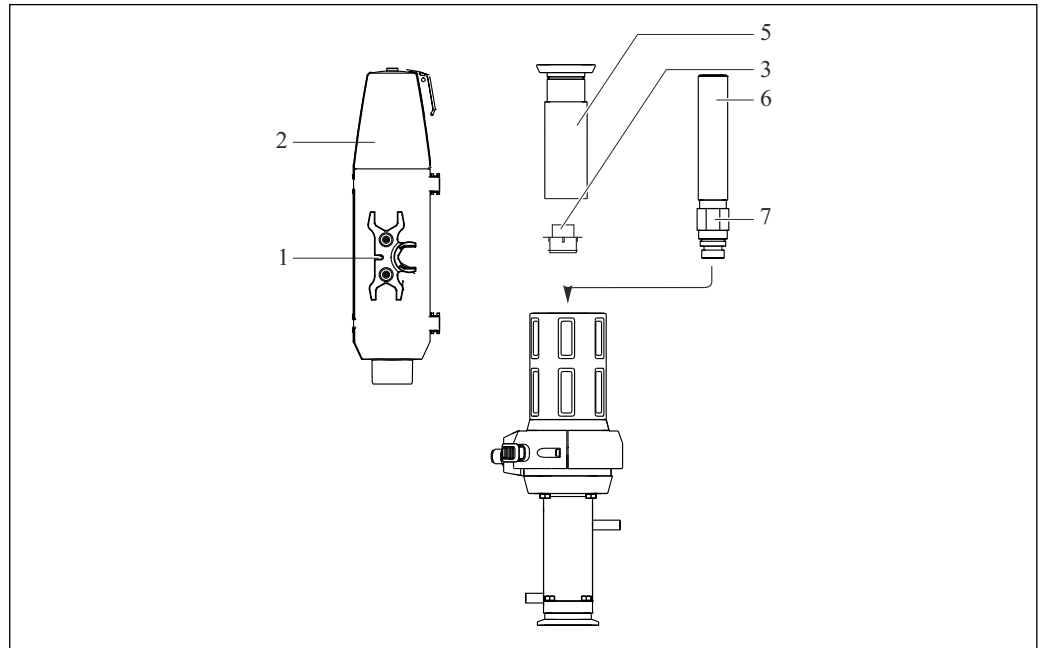

A0030188

#### 42 Sensor installation, Part 1

- 1 Open-ended wrench (AF 17/19 mm)
- 2 Cover
- 3 Dummy plug (protective cap)
- 5 Retraction pipe
- 6 Gel - KCl adapter
- 7 Lock nut

- i** Gel sensors can be installed in this version. To install KCl sensors, you will need a "Gel - KCl adapter".

Install the sensor as follows:

1. Remove the cover (→ 42, item 2) (only possible if the assembly is in the service position).
2. Unscrew the retraction pipe (item 5) (in a counterclockwise direction).
3. Turn the lock nut (item 7) on the "Gel - KCl adapter" (item 6) as far as it will go in an upward direction.
4. Remove the yellow dummy plug (item 3).
5. Screw in the "Gel - KCl adapter" (item 6) in place of the dummy plug and hand-tighten (3 Nm (2.2 lbf ft)).
6. Hand-tighten the lock nut in a clockwise direction, and then use an open-ended wrench (AF 24 mm) to tighten it by ¼ turn.
7. Screw in the retraction pipe again.
8. Screw in the sensor (→ 43, item 4) using the open-ended wrench (item 1) and hand-tighten (3 Nm (2.2 lbf ft)).
9. Secure the open-ended wrench back in the cover.

10. Mount the cover on the assembly. When doing so, guide the measuring cable through the cable grommet (top of cover).

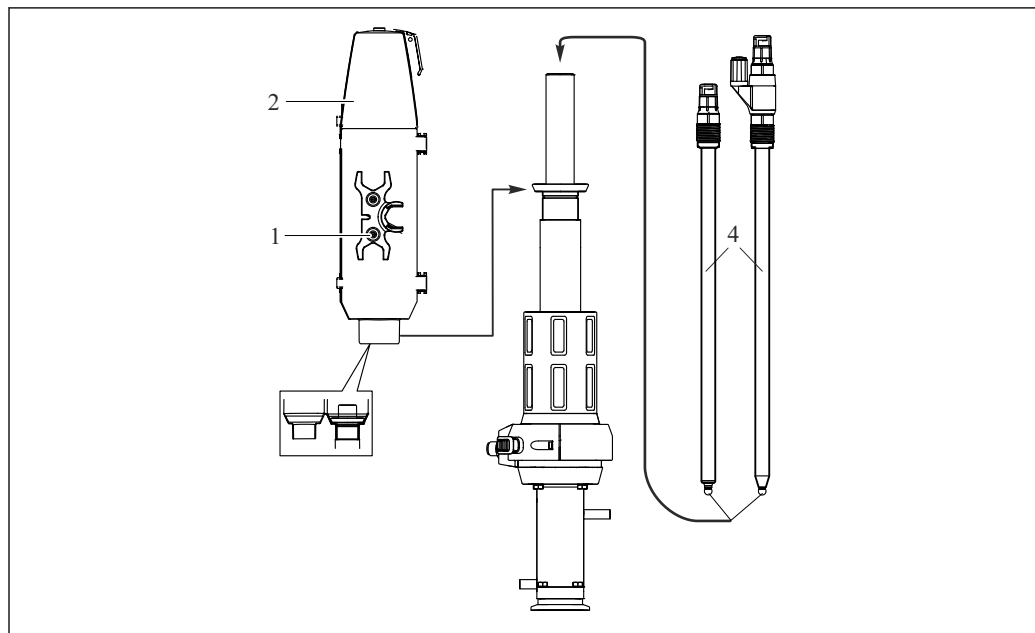

A0030189

43 Sensor installation, Part 2

- 1 Open-ended wrench  
 2 Cover  
 4 360 mm gel or KCl sensor

**i** Always mount the cover before moving the assembly to measuring position. The cover cannot be removed in the measuring position and therefore prevents the removal of the sensor.

## 5.3 Post-mounting check

Put the sensor into operation only if you can answer "yes" to the following questions:

- Are the sensor and cable undamaged?
- Is the orientation correct?
- Is the sensor installed in an assembly and not suspended from the cable?

### 5.3.1 Checking that the sealing system is intact

Check the seals after mounting or removing the sensor and when maintenance work is performed. At regular intervals.

1. Move the assembly to the service position
2. If provided, open the ball valve of the service chamber outlet
  - ↳ It is normal for a slight amount of medium to escape (connection between the service chamber and process during insertion/retraction).
3. If provided, rinse the service chamber/sensor.
4. Observe the outlet. No more medium should escape after a short period of time.
5. If medium continues to escape, the sealing system is damaged; take the measuring point out of service and perform maintenance on the assembly.

## 6 Commissioning

### 6.1 Preliminaries

Before commissioning, ensure that:

- all seals are correctly seated (on the assembly and on the process connection).
- the sensor is correctly installed and connected.
- the water connection at the rinse connections is correct (if present) or the rinse connections are sealed.

**⚠ WARNING**

**Risk of injury from high pressure, high temperature or chemical hazards if process medium escapes.**

- ▶ Check the connections to ensure they are sealed tightly.

**⚠ WARNING**

**Process medium may escape during insertion/retraction.**

- ▶ Check that the process seal is intact.
- ▶ Pipe-fit the rinse chamber outlet accordingly.
- ▶ Seal the rinse connections with dummy plugs.

**i** Note that when the assembly is inserted/retracted, an open connection exists for a short period between the process and service chamber. This intermediate position can be used for what is known as "sealing water" or for the third lock position (see "Optional cleaning/sterilization of process seal").

Install the service chamber connections accordingly.

## 7 Operation

### 7.1 Adapting the assembly to the process conditions

**CAUTION**

Due to the operating principle, there is a connection between the process and the service chamber. The service chamber can be pressurized as a result.

Process medium may escape during insertion/retraction.

- ▶ Check that the process seal is intact.
- ▶ Pipe-fit the rinse chamber outlet accordingly.
- ▶ Seal the rinse connections with dummy plugs.

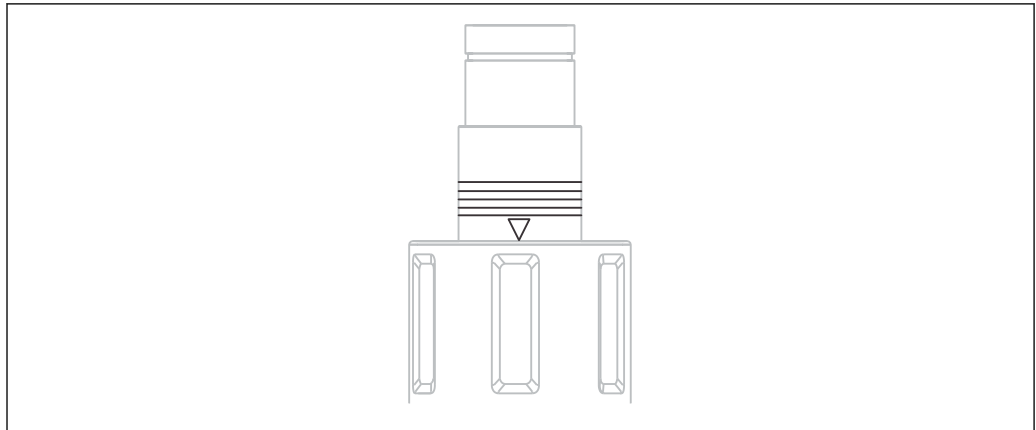

A0023307

44 Position markings (service position)

#### Assembly with pneumatic drive

The assembly with pneumatic drive does not have any operating elements.

#### Assembly with manual drive

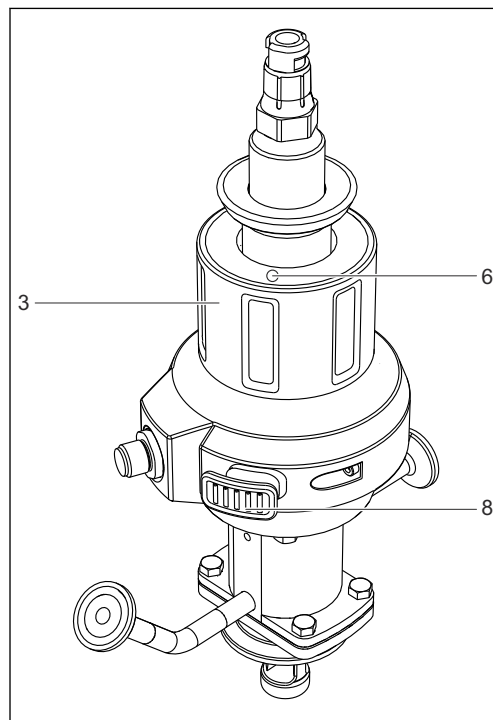

- 3 Manual drive
- 6 Unlocking button (service position)
- 8 Unlocking button (measuring position)

A0030299

45 Operating elements



### 7.1.1 Manual operation

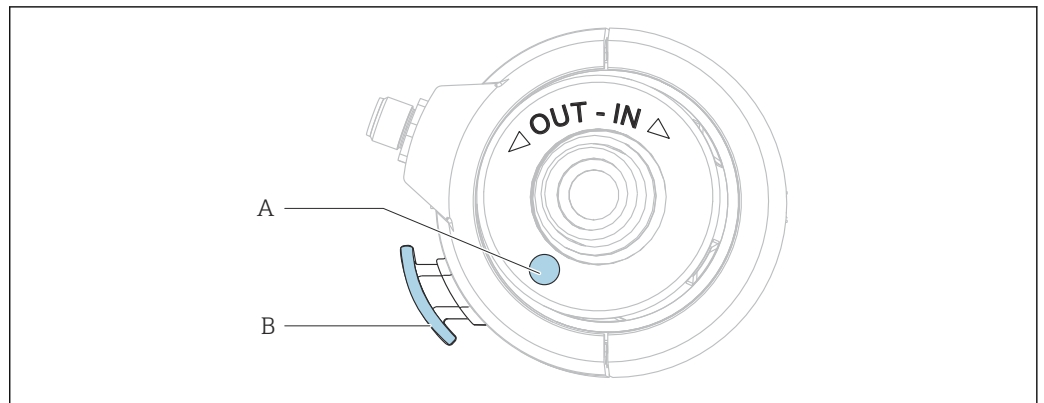

46 Direction of rotation

A Unlocking button (service position)

B Unlocking button (measuring position)

#### Moving the assembly from the service position to the measuring position

The assembly can only be inserted/retracted if a sensor is installed.

1. Press the unlocking button (A).
2. With the unlocking button (A) pressed, during the first quarter turn, rotate the drive in a clockwise direction so that the sensor holder moves into the process (only possible with the sensor installed). The button can be released while turning the rest of the way.
3. Rotate the drive until the lock engages.

#### Moving the assembly from the measuring position to the service position

1. Press the unlocking button (B).
2. With the unlocking button (B) pressed during the first quarter turn, rotate the drive in a counterclockwise direction until the stop (service position).
3. Perform the required service activities.

### 7.1.2 Pneumatic operation

The assembly can only be inserted/retracted if a sensor is installed.

The operation of the pneumatic version depends on the controller. Consult the controller manual for instructions.

Use a pneumatic pilot valve (4/2-way or 5/2-way) to insert/retract the assembly.

- ▶ Connect the two inputs.
  - ↳ If only one input is connected (e.g. for test purposes), the piston is blocked as the sensor guide moves before the limit position lock is disabled.

### Inserting/retracting the assembly if the compressed air supply fails

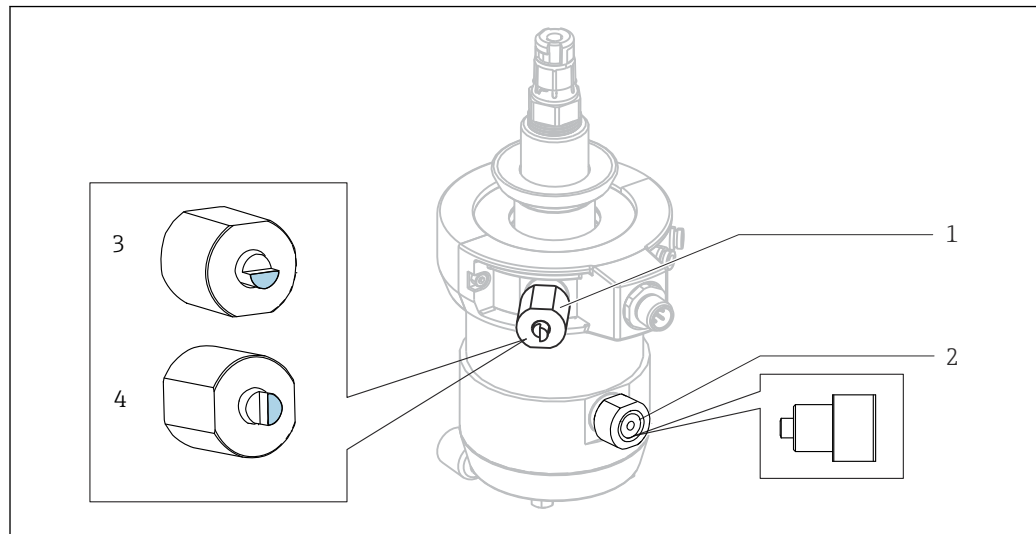

47 Failure of compressed air supply

- 1 Limit position lock for service position
- 2 Limit position lock for measuring position
- 3 Normal position (flat side at top)
- 4 Position for optional sterilization of the seal (flat side is on left)

#### **CAUTION**

#### **Risk of injury due to high medium pressure**

- Depressurize the system.

If the compressed air supply fails, you can still move the assembly manually. Proceed as follows here:

1. Use an open-ended wrench (AF 17 mm) to unscrew both limit position locks (item 1 and 2).
2. Move the assembly to the desired position.
3. Screw the limit position lock back in (Only in the case of optional sterilization of the process seal: Re-install the lock in the normal position (item 3)).

#### **Optional cleaning/sterilization of process seal**

In this version, you can clean and sterilize the process seal. To do so, proceed as follows:

1. Move the assembly to service position.
2. Use the open-ended wrench to rotate the pin for the limit position lock (item 1) from item 3 to item 4.
3. Move the assembly to measuring position.
  - ↳ The assembly now moves in the direction of the measuring position and remains in the "third lock position". When cleaning/sterilizing the service chamber, the process seal is now also cleaned/sterilized.
4. Following cleaning/sterilization, move the assembly to service position.
5. Use the open-ended wrench to rotate the pin for the limit position lock from item 4 to item 3.

Move the assembly to measuring position and continue measuring.

## 8 Maintenance



### WARNING

#### Risk of injury if medium escapes

- ▶ Before each maintenance task, ensure that the process pipe is empty and rinsed.
- ▶ Move the assembly to service position.
- ▶ The assembly may contain residual medium; please rinse thoroughly before commencing work.

 The assembly drive is maintenance-free. It is not possible to carry out maintenance or repair work on the drive.

### 8.1 Maintenance schedule

-  A maintenance log is recommended to adapt to the correct maintenance intervals.
-  The specified intervals serve as a guide. For harsh process or ambient conditions, it is recommended that the interval be shortened accordingly. Cleaning intervals for the sensor and assembly are dependent on the medium.
-  Following cleaning or replacement, apply a generous layer of Klüber XPC0003-V+R8 grease to the seals.

Interval	Maintenance measures
During initial commissioning / when putting back into service after maintenance	<ul style="list-style-type: none"> <li>▶ Perform an initial inspection.</li> <li>▶ Check the locking mechanism (no movement without a sensor).</li> <li>▶ Check the stop bolt (no movement without compressed air).</li> </ul>
Regularly	<p>Visual inspection:</p> <ul style="list-style-type: none"> <li>▶ Check assembly retraction.</li> <li>▶ Clean and lubricate the retraction pipe depending on the fouling.</li> <li>▶ Check that all connections are sealed tightly.</li> </ul> <p>Check for tightness:</p> <ul style="list-style-type: none"> <li>▪ Rinse lines</li> <li>▪ Process connection</li> <li>▪ Compressed air hoses (pneumatic drive).</li> </ul> <p>Clean the process seal using the sealing water function:</p> <ul style="list-style-type: none"> <li>▶ Close the rinse chamber outlet.</li> <li>▶ Rinse in the process in order to clean the seals.</li> </ul>
Monthly or after 500 strokes (whichever comes first)	<ul style="list-style-type: none"> <li>▶ Check that the process seal is intact.</li> <li>▶ Replace the seals if medium is escaping.</li> <li>▶ Check the leakage hole: remove the screw for this purpose.</li> </ul> <p>Does medium escape from the leakage hole when the assembly is moving? This can be an indicator of faulty inner O-rings in the service chamber or faulty immersion tube O-rings in the case of the double chamber assembly.</p> <p>Version without 3-A:</p> <ol style="list-style-type: none"> <li>1. Check the leakage hole of the service chamber.</li> <li>2. Clean the assembly thoroughly.</li> <li>3. Replace seals in contact with the medium.</li> </ol> <p>Version with 3-A:</p> <ol style="list-style-type: none"> <li>1. Check the leak paths.</li> <li>2. Clean the assembly thoroughly.</li> <li>3. Replace seals in contact with the medium.</li> </ol>

Interval	Maintenance measures
	<ol style="list-style-type: none"> <li>1. Inspect the sensor.</li> <li>2. Disassemble the sensor.</li> <li>3. Check the sensor for deposits.</li> <li>4. If deposits are found: check the cleaning cycle (cleaning media, temperature, duration, flow rate).</li> </ol> <p>When process pressure is applied and cleaning disabled, there should be no discharge of medium from the assembly's rinse chamber outlet.</p> <ul style="list-style-type: none"> <li>▶ Check for defective process seal(s).</li> </ul>
Biannually or after 5000 strokes (whichever comes first)	<ul style="list-style-type: none"> <li>▶ Clean the assembly thoroughly.</li> <li>▶ Remove the residual medium.</li> <li>▶ Replace all seals in contact with the medium.</li> <li>▶ Clean the retraction pipe.</li> <li>▶ Lubricate the retraction pipe.</li> </ul> <ol style="list-style-type: none"> <li>1. Check mobility of retraction protection.</li> <li>2. Remove the sensor.                             <ul style="list-style-type: none"> <li>↳ The contact surface of the sensor in the assembly is spring-loaded and must be free to move.</li> </ul> </li> </ol> <p>Possible cause of failure: contamination inside the drive, e.g. caused by a broken sensor.</p>

## 8.2 Maintenance work

### 8.2.1 Cleaning agent



#### Organic solvents containing halogens

Limited evidence of carcinogenicity! Dangerous for the environment with long-term effects!

- ▶ Do not use organic solvents that contain halogens.



#### Thiocarbamide

Harmful if swallowed! Limited evidence of carcinogenicity! Possible risk of harm to the unborn child! Dangerous for the environment with long-term effects!

- ▶ Wear protective goggles, protective gloves and appropriate protective clothing.
- ▶ Avoid all contact with the eyes, mouth and skin.
- ▶ Avoid discharge into the environment.

The most common types of soiling and the appropriate cleaning agents in each case are shown in the following table.



Pay attention to the material compatibility of the materials to be cleaned.

Type of soiling	Cleaning agent
Greases and oils	Hot water or tempered, surfactant-containing (basic) agents or water-soluble organic solvents (e.g. ethanol)
Limescale deposits, metal hydroxide buildup, lyophobic biological buildup	approx. 3% hydrochloric acid
Sulfide deposits	Mixture of 3% hydrochloric acid and thiocarbamide (commercially available)

Type of soiling	Cleaning agent
Protein buildup	Mixture of 3% hydrochloric acid and pepsin (commercially available)
Fibers, suspended substances	Pressurized water, possibly surface-active agents
Light biological buildup	Pressurized water

- ▶ Choose a cleaning agent to suit the degree and type of soiling.

## 8.2.2 Cleaning the assembly

### WARNING

#### Risk of injury if medium escapes

- ▶ Before each maintenance task, ensure that the process pipe is empty and rinsed.
- ▶ Move the assembly to service position.
- ▶ The assembly may contain residual medium; please rinse thoroughly before commencing work.

### WARNING

#### Loss of proper functionality.



- ▶ Do not open or disassemble the drive.
- ▶ Only the O-ring on the base of the retraction pipe should be renewed during maintenance.
- ▶ Clean and lubricate the retraction pipe regularly.

For stable and safe measurements:

1. Clean the assembly and sensor regularly. The frequency and intensity of the cleaning depend on the medium.
2. Use isopropyl alcohol to clean metal parts, but not the O-rings.

### Manually operated assembly

All parts in contact with the medium, such as the sensor and the sensor guide, must be cleaned regularly.

1. Remove the sensor in the logically reverse sequence to the mounting procedure.  
→  34
2. Remove light dirt and fouling with suitable cleaning solutions. (→  44
3. Remove heavy soiling using a soft brush and a suitable cleaning agent.
4. For very persistent dirt, soak the parts in a cleaning solution. Then clean the parts with a brush.

 A typical example of a cleaning interval would be 6 months in the case of drinking water.

### Pneumatically controlled assembly

Regular, pneumatically controlled cleaning is recommended using the rinse water connection and the appropriate equipment.

1. Take apart parts that are in contact with the medium.
2. Clean parts that are in contact with the medium.
3. Clean metal parts with isopropyl alcohol. Do not use isopropyl alcohol to clean the O-rings.

## 8.2.3 Cleaning the sensor

→ Documentation of the connected sensor

1. Always clean ORP electrodes mechanically and with water.
2. Do not use chemical cleaning agents.
  - ↳ Such cleaning agents cause a potential to build up at the electrode which takes a few hours to dissipate. The potential causes errors in the measurement.
3. Do not use abrasive cleaning agents.
  - ↳ These can cause irreparable damage to the sensor.
4. Perform another calibration following cleaning if necessary.

Clean the sensor:

- Before every calibration
- Regularly during operation
- Before returning it for repairs

You can remove the sensor and clean it manually, or you can clean it in automatic mode <sup>1)</sup> using the rinse water connection.

In event of minor deposit build-up:

1. Place the sensor in warm water.
2. Clean the sensor with a mild dishwashing detergent.

---

1) only if the assembly is fitted out accordingly

## 8.2.4 Replacing seals

To replace the seals in the assembly, you must interrupt the process and remove the assembly completely.

### **⚠ CAUTION**

#### **Risk of injury due to residual medium and elevated temperatures**

- ▶ When handling parts that are in contact with the medium, protect against residual medium and elevated temperatures. Wear protective goggles and safety gloves.

### **⚠ CAUTION**

#### **Increased wear on seals subject to dynamic load**

- ▶ Lubricate seals sufficiently, e.g. with Paraliq GTE 703.
- ▶ Reduce maintenance cycles.
- ▶ Clean the assembly prior to replacing seals. (→ 📄 46)

#### **Preparation:**

1. Interrupt the process. Pay attention to residual medium, residual pressure as well as elevated temperatures.
2. Move the assembly to service position.
3. Completely detach the assembly from the process connection.
4. Clean the assembly. (→ 📄 46)

The following sections describe how to replace the seals. The following table serves as a guide to the relevant sections.

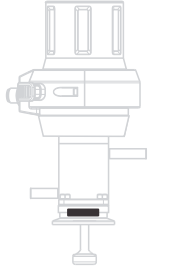
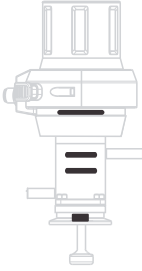
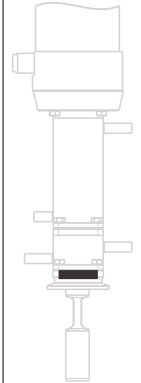
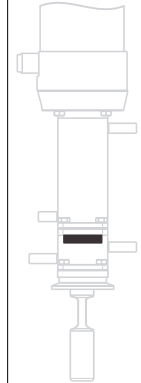
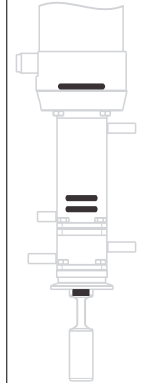
 <p>A0023215</p> <p>Molded seal - process connection (A)</p>	 <p>A0023216</p> <p>O-rings - single chamber (B)</p>	 <p>A0023214</p> <p>Molded seal - process connection, double chamber (C)</p>	 <p>A0023213</p> <p>Molded seal - front chamber (D)</p>	 <p>A0023212</p> <p>Seals - inner double chamber (E)</p>
---	---	---	--	---

#### **Checking that the sealing system is intact**

Check the seals after mounting or removing the sensor and when maintenance work is performed. At regular intervals.

1. Move the assembly to the service position
2. If provided, open the ball valve of the service chamber outlet
  - ↳ It is normal for a slight amount of medium to escape (connection between the service chamber and process during insertion/retraction).
3. If provided, rinse the service chamber/sensor.
4. Observe the outlet. No more medium should escape after a short period of time.



5. If medium continues to escape, the sealing system is damaged; take the measuring point out of service and perform maintenance on the assembly.

### Retraction pipe

#### Seal replacement in the retraction pipe

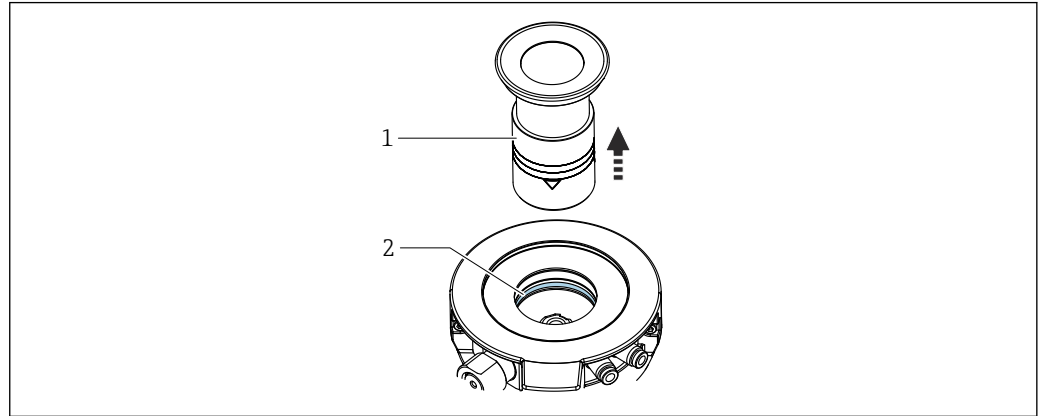

- 1 Retraction pipe
- 2 O-ring

1. Unscrew the retraction pipe (1) from the assembly.
2. In the pneumatic version, unscrew the automatic limit position locks with a combination wrench (AF 17).
3. Move the assembly to measuring position manually.
4. Use a suitable tool, e.g. a spark plug wrench, to press the protection pipe carefully downwards.
5. Remove the exposed O-ring (2) from the groove using an O-ring picker.
6. Apply a thin layer of grease (e.g. Klüber Paraliq GTE 703) to the retraction pipe (1).
7. Grease the O-Ring and insert.
8. Mount the retraction pipe (1) and, where applicable, the pneumatic limit position locks on the assembly.

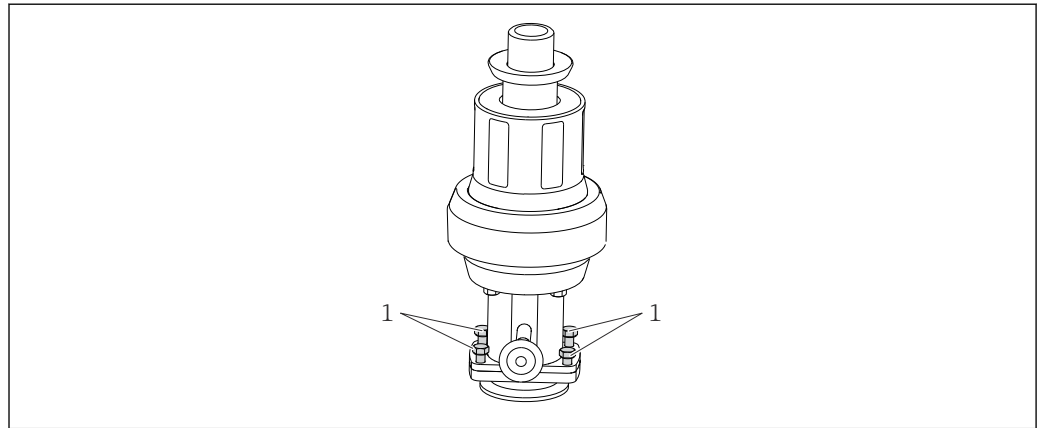
**Molded seal - process connection (A)**

A0030357

**48 Replacing seals, Part 1**

1 Securing screws

1. Release four securing screws (pos. 1).

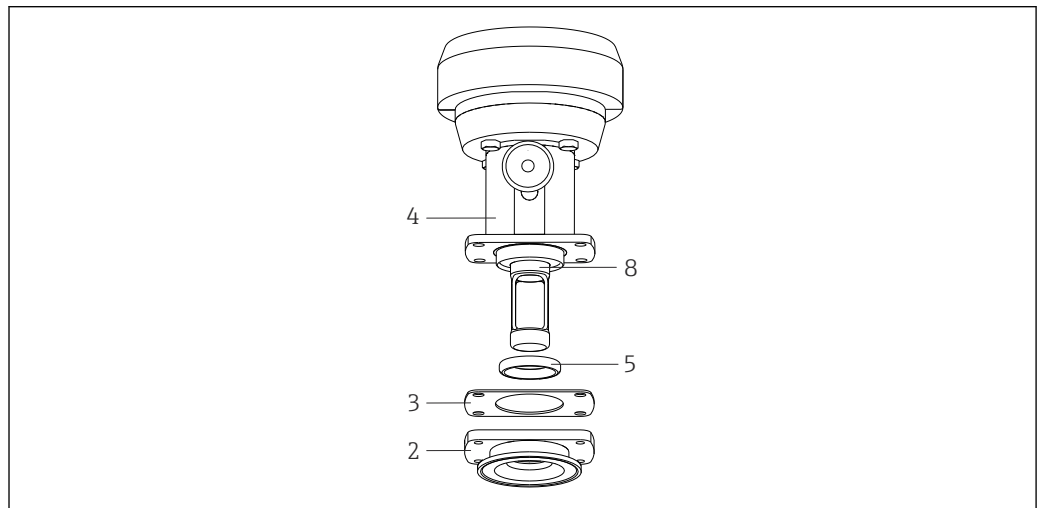

A0030365

**49 Replacing seals, Part 2**

2 Process connection  
 3 Gasket  
 4 Service chamber  
 5 Molded seal  
 6 Immersion tube

2. Remove the process connection (pos. 2).
3. Take the molded seal (pos. 5) out of the process connection.
4. Apply a thin layer of grease to the new molded seal (e.g., Klüber Paraliq GTE 703).
5. Slide the molded seal over the immersion tube (pos. 8) and into the guide groove of the service chamber. Ensure that the molded seal is seated correctly.
6. Position the gasket (pos. 3) on the service chamber.
7. Attach the process connection to the service chamber.
8. Tighten the four securing screws with a torque of 4 Nm.

## O-rings - single chamber (B)

### O-rings

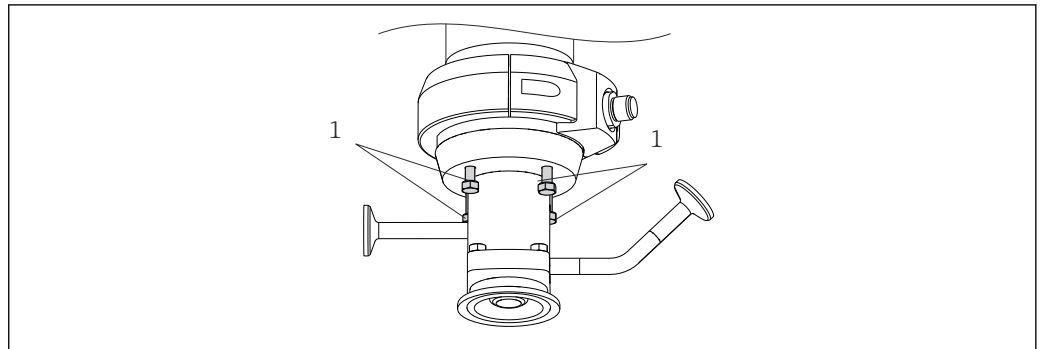

A0030356

#### 50 Replacing seals, Part 1

1 Securing screws

1. Release the four securing screws (item 1).
2. Remove the service chamber (item 3) with the process connection (item 2).

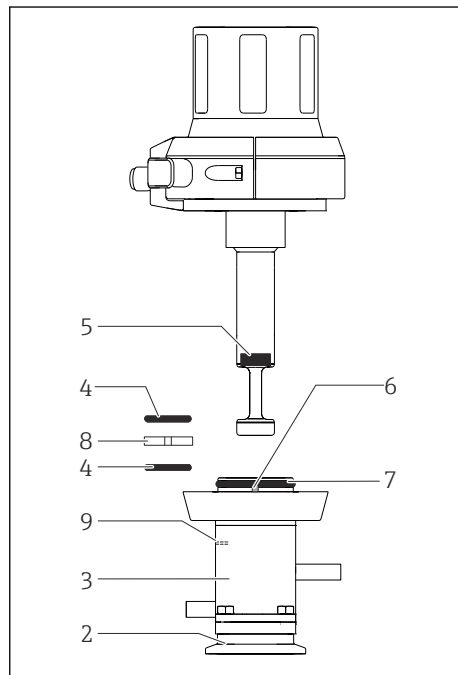



A0030364

#### 51 Replacing seals, Part 2

3. Use a tweezers to remove both O-rings (item 4) from the service chamber.
4. Pneumatic drive only: Use a thin screwdriver to push through the leakage hole (item 9).
  - ↳ The slide bushing (item 8) is pushed out of the guide groove.
5. Use a tweezers to remove the slide bushing.
6. Apply a thin layer of grease (e.g., Klüber Paraliq GTE 703) to the new O-rings and the new slide bushing.
7. Pneumatic drive only: Insert the slide bushing into the middle guide groove.
8. Insert the two O-rings into the corresponding grooves in the service chamber.



**Molded seal**

1. Remove the molded seal (→  51,  51 item 5) using a tweezers or long-nosed pliers.
2. Apply a thin layer of grease to the molded seal.
3. Press the molded seal into the guide groove of the immersion tube. Ensure that the molded seal is seated correctly.

 If you insert a dummy sensor or circular rod (Ø 12 mm) until it protrudes just above the seal, the molded seal cannot move upwards while it is being inserted.

**Pneumatic drive**

Pneumatic drive only:

1. Remove the O-ring (→  51,  51 item 7).
2. Apply a thin layer of grease to the molded seal.
3. Press the molded seal into the guide groove of the immersion tube. Ensure that the molded seal is seated correctly.
4. Mount the service chamber together with the process connection on the assembly. Pay attention to the positioning pin (item 6).
5. Tighten the four securing screws with a torque of 4 Nm.

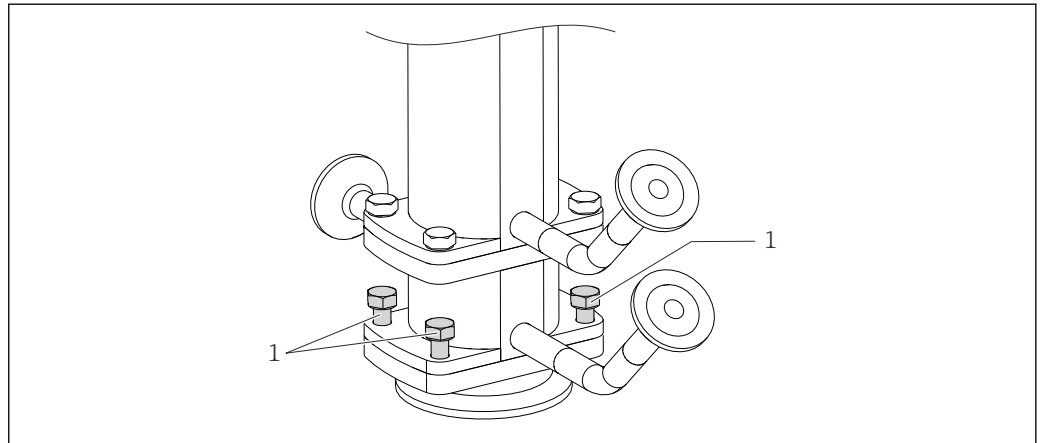
**Molded seal - process connection, double chamber (C)**

A0030358

**52** Replacing seals, Part 1

1 Securing screws

1. Release the four securing screws (pos. 1).

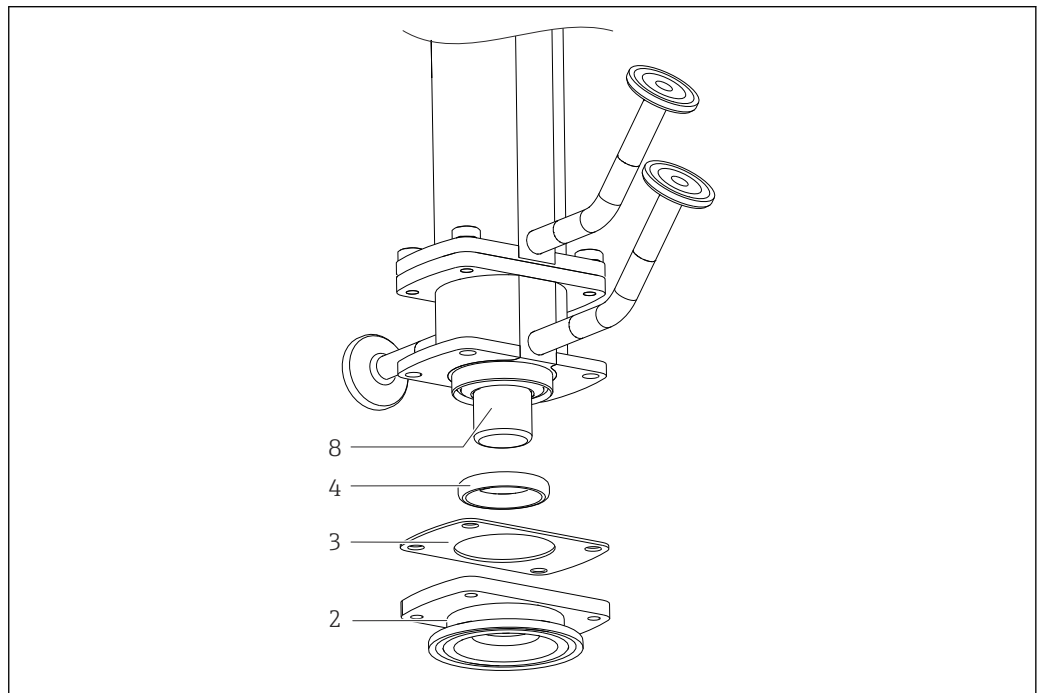

A0030359

**53** Replacing seals, Part 2

2 Process connection

3 Gasket

4 Molded seal

8 Immersion tube

2. Remove the process connection (pos. 2).
3. Remove the molded seal (pos. 4) from the process connection.
4. Apply a thin layer of grease to the new molded seal (e.g., Klüber Paraliq GTE 703).
5. Slide the molded seal over the immersion tube (pos. 8) and into the guide groove of the service chamber. Ensure that the molded seal is seated correctly.
6. Position the gasket (pos. 3) on the rinse chamber.
7. Attach the process connection to the "inner" service chamber.
8. Tighten the four securing screws with a torque of 4 Nm.

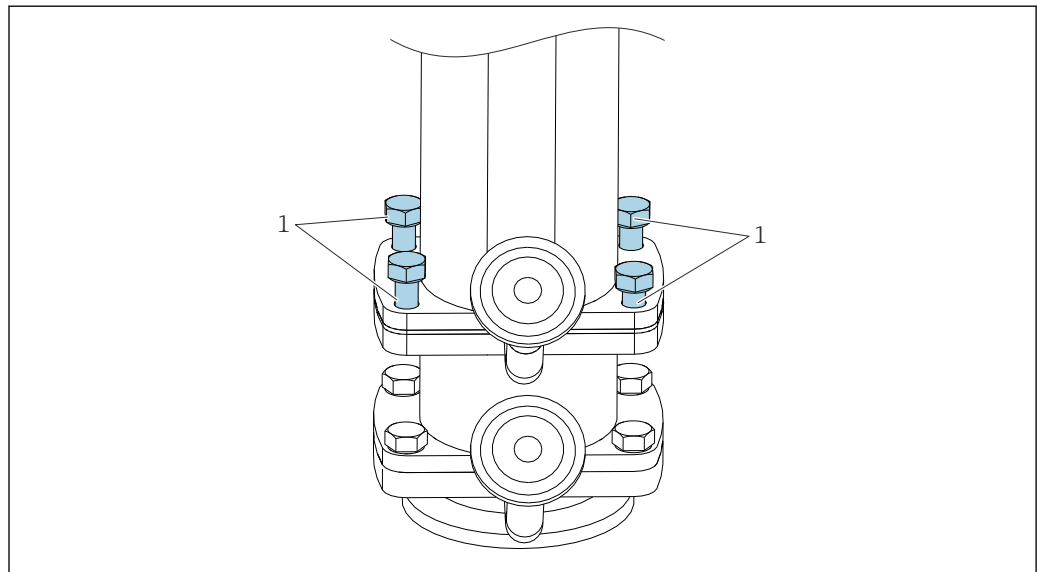
**Molded seal - "front" service chamber (D)**

A0030360

**54** Replacing seals, Part 1

1 Securing screws

1. Release the four securing screws (item 1).

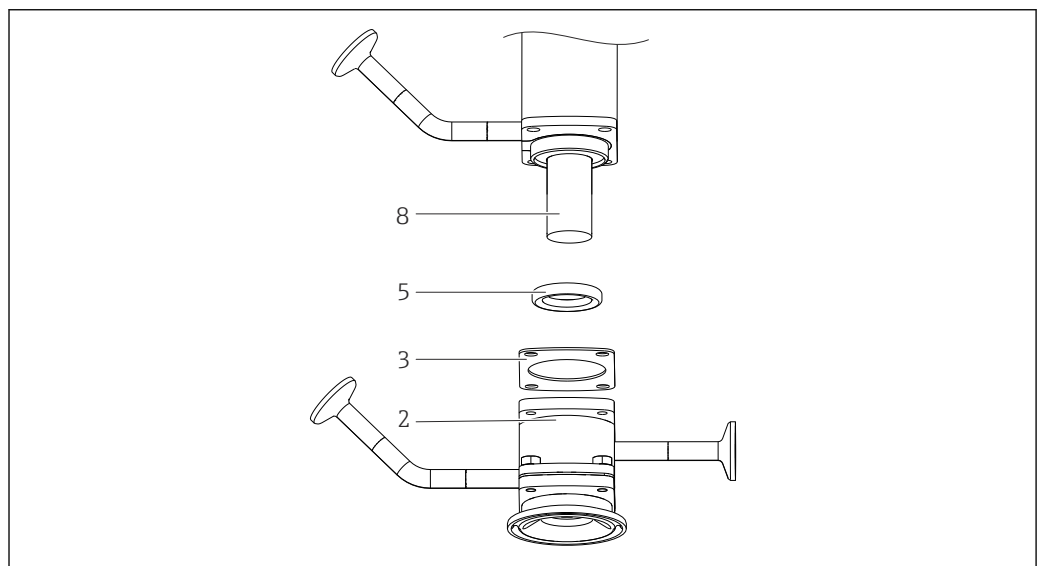

A0030366

**55** Replacing seals, Part 2

2 "Front" service chamber with process connection

3 Gasket

5 Molded seal

8 Immersion tube

2. Remove the "front" service chamber with the process connection (item 2).
3. Remove the molded seal (item 5) from the "front" service chamber.
4. Apply a thin layer of grease to the new molded seal (e.g., Klüber Paraliq GTE 703).
5. Slide the molded seal over the immersion tube (item 8) and into the guide groove of the service chamber. Ensure that the molded seal is seated correctly.
6. Position the gasket (item 3) on the front chamber.
7. Attach the front chamber together with the process connection to the "inner" service chamber.

8. Tighten the four securing screws with a torque of 4 Nm.

## Seals - inner double chamber (E)

### O-ring in process connection

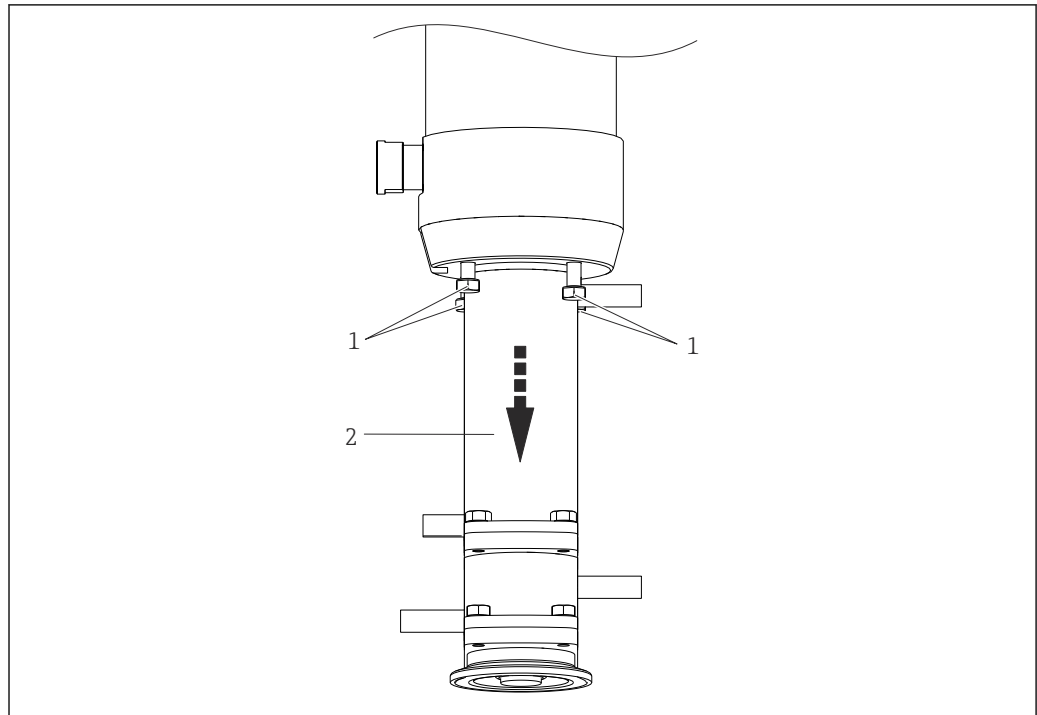

A0030361

#### 56 Replacing seals, Part 1

- 1 Securing screws
- 2 Service chamber with front chamber and process connection

1. Release the four securing screws (item 1).
2. Remove the service chamber with front chamber and process connection (item 2).

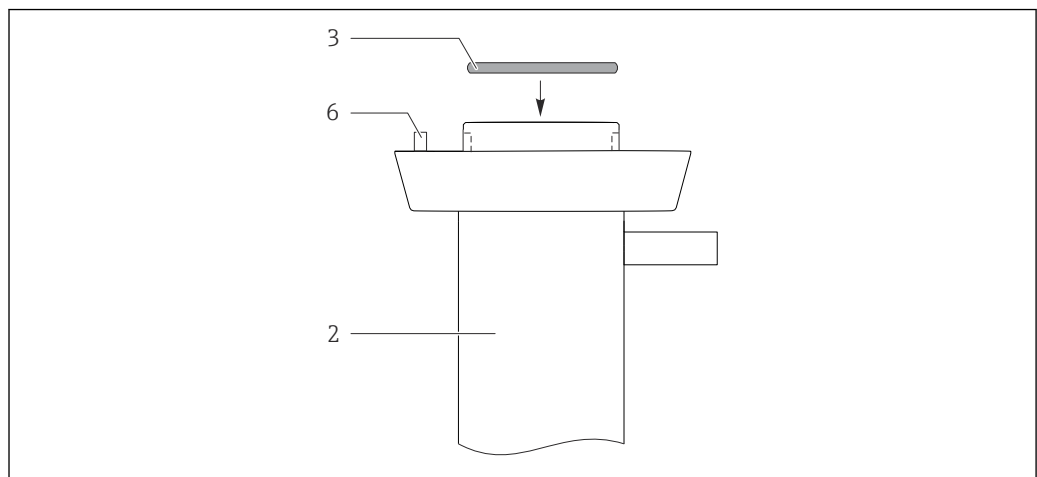

A0030363

#### 57 Replacing seals, Part 2

- 2 "Inner" service chamber with "front" service chamber and process connection
- 3 O-ring
- 6 Positioning pin

3. Remove the O-ring (item 3).
4. Apply a thin layer of grease to the new O-ring (e.g., Klüber Paraliq GTE 703) and
5. position the O-ring in the groove.



### Molded seal

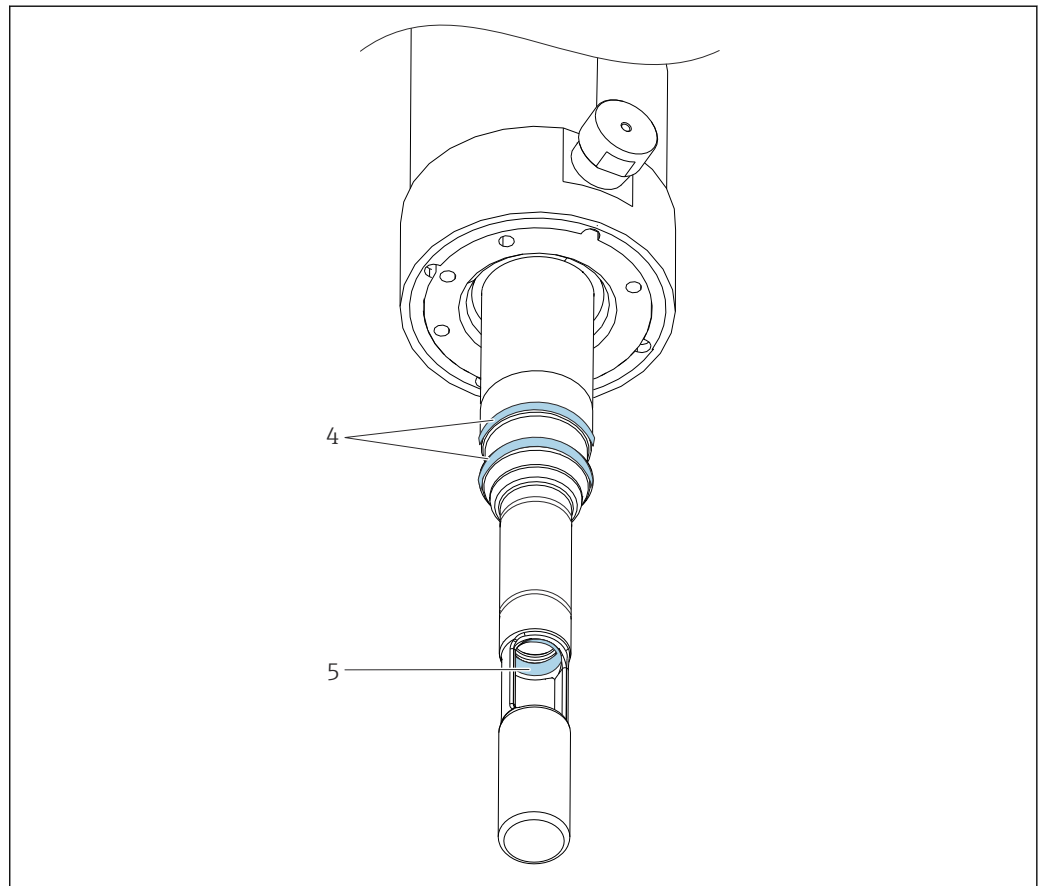

A0030362

#### 🔧 58 Replacing seals, Part 3

- 4 O-rings
- 5 Molded seal

1. Remove the molded seal (item 5) using a tweezers or long-nosed pliers.
2. Apply a thin layer of grease to the new molded seal (e.g., Klüber Paraliq GTE 703).
3. Press the molded seal into the guide groove of the immersion tube. Ensure that the molded seal is seated correctly.

**i** If you insert a dummy sensor or circular rod (Ø 12 mm) until it protrudes just above the seal, the molded seal cannot move upwards while it is being inserted.

#### O-rings in the immersion tube

1. Remove both O-rings (→ 🔧 58, 📄 57 item 4).
2. Apply a thin layer of grease to the new O-rings.
3. Position the O-rings in the two grooves.
4. Attach the "inner" service chamber with "front" service chamber and process connection to the assembly. Pay attention to the positioning pin (item 6).
5. Tighten the securing screws with a torque of 4 Nm.

## 9 Repair

### 9.1 General information

The repair and conversion concept provides for the following:

- The product has a modular design
- Spare parts are grouped into kits which include the associated kit instructions
- Only use original spare parts from the manufacturer
- Repairs are carried out by the manufacturer's Service Department or by trained users
- Certified devices can only be converted to other certified device versions by the manufacturer's Service Department or at the factory
- Observe applicable standards, national regulations, Ex documentation (XA) and certificates

1. Carry out the repair according to the kit instructions.
2. Document the repair and conversion and enter, or have entered, in the Life Cycle Management tool (W@M).

#### **WARNING**

##### **Danger resulting from improper repair!**

- ▶ Any damage to the assembly that compromises pressure safety must be repaired only by authorized and qualified personnel.
- ▶ Damage to the drive can be repaired only at the place of manufacture. Repairs cannot be carried out onsite.
- ▶ Following each repair and maintenance task, check the assembly for leaks using appropriate procedures. Following this, the assembly must again comply with the specifications in the technical data.
- ▶ Replace all other damaged components immediately.
- ▶ Following repairs, check that the device is complete, in a safe condition and functioning correctly.

### 9.2 Spare parts

Device spare parts that are currently available for delivery can be found on the website:

<https://portal.endress.com/webapp/SparePartFinder>

- ▶ Quote the serial number of the device when ordering spare parts.

### 9.3 Return

The product must be returned if repairs or a factory calibration are required, or if the wrong product was ordered or delivered. As an ISO-certified company and also due to legal regulations, Endress+Hauser is obliged to follow certain procedures when handling any returned products that have been in contact with medium.

To ensure the swift, safe and professional return of the device:

- ▶ Check the website [www.endress.com/support/return-material](http://www.endress.com/support/return-material) for information on the procedure and general conditions.

## 9.4 Disposal



If required by the Directive 2012/19/EU on waste electrical and electronic equipment (WEEE), the product is marked with the depicted symbol in order to minimize the disposal of WEEE as unsorted municipal waste. Do not dispose of products bearing this marking as unsorted municipal waste. Instead, return them to the manufacturer for disposal under the applicable conditions.

## 10 Accessories

The following are the most important accessories available at the time this documentation was issued.

Listed accessories are technically compatible with the product in the instructions.

1. Application-specific restrictions of the product combination are possible.  
Ensure conformity of the measuring point to the application. This is the responsibility of the operator of the measuring point.
2. Pay attention to the information in the instructions for all products, particularly the technical data.
3. For accessories not listed here, please contact your Service or Sales Center.

The following accessories can be ordered via the product structure or the XPC0001 spare part structure:

- Weld-in adapter G1¼, straight, 35 mm, 1.4435 (AISI 316 L), safety nozzle
- Weld-in adapter G1¼, angled, 35 mm, 1.4435 (AISI 316 L), safety nozzle

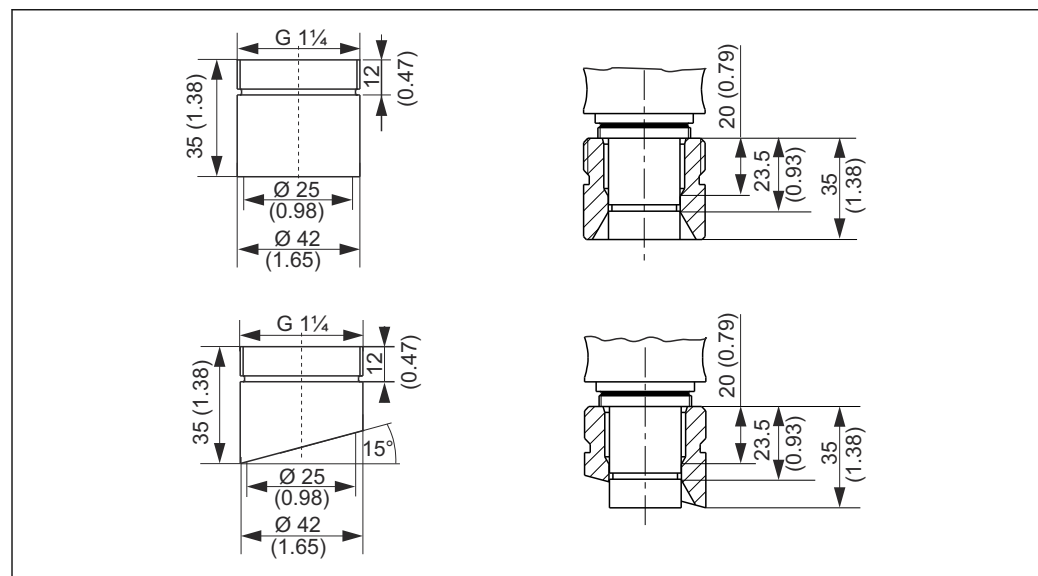

59 Weld-in adapter (safety nozzle), dimensions in mm (in)

- Dummy plug G1¼, 1.4435 (AISI 316 L), FPM - FDA
- Sensor dummy 225 mm, 1.4435 (AISI 316 L), Ra = 0.38 µm
- Sensor dummy 360 mm, 1.4435 (AISI 316 L), Ra = 0.38 µm
- Kit, EPDM FDA seals only for process connection G1¼, wetted parts, single chamber
- Kit, FKM FDA seals only for process connection G1¼, wetted parts, single chamber
- Kit, FFKM FDA seals only for process connection G1¼, wetted parts, single chamber
- Kit, EPDM FDA seals, wetted parts, single chamber, not for process connection G1¼
- Kit, FKM FDA seals, wetted parts, single chamber, not for process connection G1¼
- Kit, FFKM FDA seals, wetted parts, single chamber, not for process connection G1¼
- Kit, EPDM FDA seals, wetted parts, double chamber, all process connections
- Kit, FKM FDA seals, wetted parts, double chamber, all process connections
- Kit, FFKM FDA seals, wetted parts, double chamber, all process connections
- Kit, seals not in contact with the medium
- Cable, plug-in, limit switch, M12, 5 m
- Cable, plug-in, limit switch, M12, 10 m

- Tool in case for installation/removal
- Kit, Klüber Paraliq GTE 703 lubricant (60g)
- Output interface terminals, version: CPA871-620-R7
  - NAMUR terminals for limit position switches
    - Operation of 8V DC feedback signals on 24V DC devices
    - Suitable for top-hat rail mounting

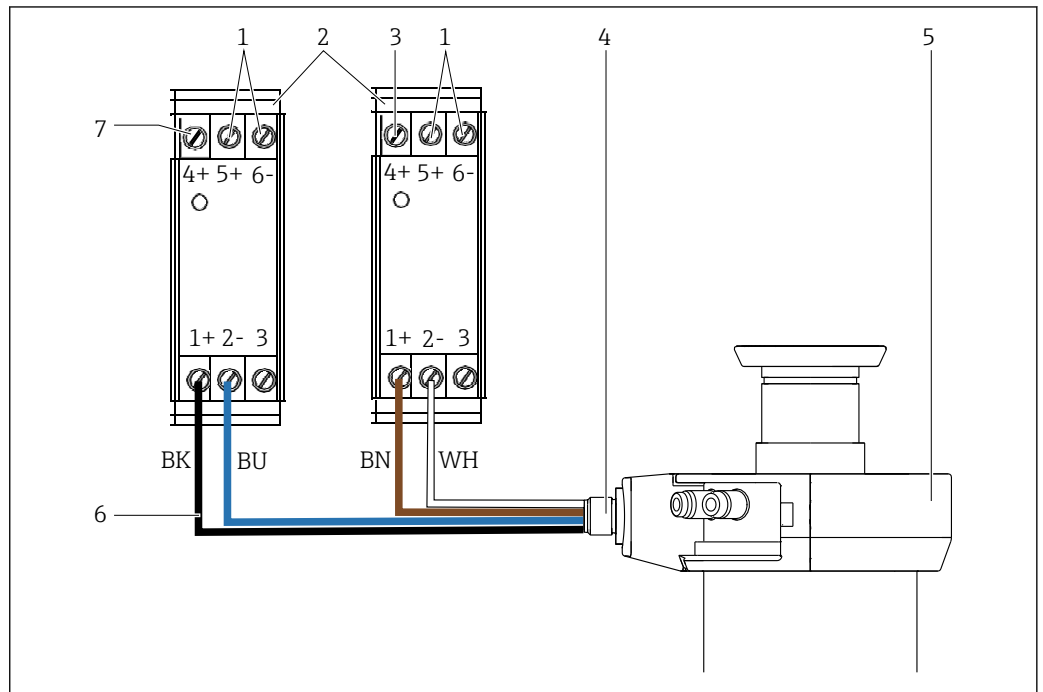

A0046169

60 Wiring of output interface terminal with assembly

- 1 Supply voltage
- 2 Output interface terminals
- 3 Output measuring position
- 4 Limit position switches
- 5 Assembly
- 6 Cable for wiring → 60
- 7 Output service position

## 10.1 Device-specific accessories

### 10.1.1 Sensors

#### pH sensors

##### Memosens CPS11E

- pH sensor for standard applications in process and environmental engineering
- Digital with Memosens 2.0 technology
- Product Configurator on the product page: [www.endress.com/cps11e](http://www.endress.com/cps11e)

 Technical Information TI01493C

##### Orbisint CPS11

- pH sensor for process technology
- With dirt-repellent PTFE diaphragm
- Product Configurator on the product page: [www.endress.com/cps11](http://www.endress.com/cps11)

 Technical Information TI00028C

**Memosens CPS31E**

- pH sensor for standard applications in drinking water and swimming pool water
- Digital with Memosens 2.0 technology
- Product Configurator on the product page: [www.endress.com/cps31e](http://www.endress.com/cps31e)

 Technical Information TI01574C

**Memosens CPS41E**

- pH sensor for process technology
- With ceramic junction and KCl liquid electrolyte
- Digital with Memosens 2.0 technology
- Product Configurator on the product page: [www.endress.com/cps41e](http://www.endress.com/cps41e)

 Technical Information TI01495C

**Ceraliquid CPS41**

- pH electrode with ceramic junction and KCl liquid electrolyte
- Product Configurator on the product page: [www.endress.com/cps41](http://www.endress.com/cps41)

 Technical Information TI00079C

**Memosens CPS61E**

- pH sensor for bioreactors in life sciences and for the food industry
- Digital with Memosens 2.0 technology
- Product Configurator on the product page: [www.endress.com/cps61e](http://www.endress.com/cps61e)

 Technical Information TI01566C

**Memosens CPS71E**

- pH sensor for chemical process applications
- Digital with Memosens 2.0 technology
- Product Configurator on the product page: [www.endress.com/cps71e](http://www.endress.com/cps71e)

 Technical Information TI01496C

**Ceragel CPS71**

- pH electrode with reference system including ion trap
- Product Configurator on the product page: [www.endress.com/cps71](http://www.endress.com/cps71)

 Technical Information TI00245C

**Memosens CPS91E**

- pH sensor for heavily polluted media
- Digital with Memosens 2.0 technology
- Product Configurator on the product page: [www.endress.com/cps91e](http://www.endress.com/cps91e)

 Technical Information TI01497C

**Orbipore CPS91**

- pH electrode with hole junction for media with high dirt load
- Product Configurator on the product page: [www.endress.com/cps91](http://www.endress.com/cps91)

 Technical Information TI00375C

**ORP sensors****Memosens CPS12E**

- ORP sensor for standard applications in process and environmental engineering
- Digital with Memosens 2.0 technology
- Product Configurator on the product page: [www.endress.com/cps12e](http://www.endress.com/cps12e)

 Technical Information TI01494C

**Orbisint CPS12**

- ORP sensor for process technology
- Product Configurator on the product page: [www.endress.com/cps12](http://www.endress.com/cps12)



Technical Information TI00367C

**Memosens CPS42E**

- ORP sensor for process technology
- Digital with Memosens 2.0 technology
- Product Configurator on the product page: [www.endress.com/cps42e](http://www.endress.com/cps42e)



Technical Information TI01575C

**Ceraliquid CPS42**

- ORP electrode with ceramic junction and KCl liquid electrolyte
- Product Configurator on the product page: [www.endress.com/cps42](http://www.endress.com/cps42)



Technical Information TI00373C

**Memosens CPS72E**

- ORP sensor for chemical process applications
- Digital with Memosens 2.0 technology
- Product Configurator on the product page: [www.endress.com/cps72e](http://www.endress.com/cps72e)



Technical Information TI01576C

**Ceragel CPS72**

- ORP electrode with reference system including ion trap
- Product Configurator on the product page: [www.endress.com/cps72](http://www.endress.com/cps72)



Technical Information TI00374C

**ISFET pH sensors****Memosens CPS47E**

- ISFET sensor for pH measurement
- Digital with Memosens 2.0 technology
- Product Configurator on the product page: [www.endress.com/cps47e](http://www.endress.com/cps47e)



Technical Information TI01616C

**Memosens CPS77E**

- Sterilizable and autoclavable ISFET sensor for pH measurement
- Digital with Memosens 2.0 technology
- Product Configurator on the product page: [www.endress.com/cps77e](http://www.endress.com/cps77e)



Technical Information TI01396

**Combined pH/ORP sensors****Memosens CPS16E**

- pH/ORP sensor for standard applications in process technology and environmental engineering
- Digital with Memosens 2.0 technology
- Product Configurator on the product page: [www.endress.com/cps16e](http://www.endress.com/cps16e)



Technical Information TI01600C

**Memosens CPS76E**

- pH/ORP sensor for process technology
- Digital with Memosens 2.0 technology
- Product Configurator on the product page: [www.endress.com/cps76e](http://www.endress.com/cps76e)



Technical Information TI01601C

**Memosens CPS96E**

- pH/ORP sensor for heavily polluted media and suspended solids
- Digital with Memosens 2.0 technology
- Product Configurator on the product page: [www.endress.com/cps96e](http://www.endress.com/cps96e)



Technical Information TI01602C

**Conductivity sensors****Memosens CLS82E**

- Hygienic conductivity sensor
- Digital with Memosens 2.0 technology
- Product Configurator on the product page: [www.endress.com/cls82e](http://www.endress.com/cls82e)



Technical Information TI01529C

**Oxygen sensors****Oxymax COS22E**

- Sterilizable sensor for dissolved oxygen
- Digital with Memosens 2.0 technology
- Product Configurator on the product page: [www.endress.com/cos22e](http://www.endress.com/cos22e)



Technical Information TI00446C

**Oxymax COS22**

- Sterilizable sensor for dissolved oxygen
- With Memosens technology or as an analog sensor
- Product Configurator on the product page: [www.endress.com/cos22](http://www.endress.com/cos22)



Technical Information TI00446C

**Absorption sensor****OUSBT66**

- NIR absorption sensor for measuring cell growth and biomass
- Sensor version suitable for pharmaceutical industry
- Product Configurator on the product page: [www.endress.com/ousbt66](http://www.endress.com/ousbt66)



Technical Information TI00469C

## 10.2 Service-specific accessories

### 10.2.1 Cleaning systems

**Air-Trol 500**

- Control unit for Cleanfit retractable assemblies
- Order No. 50051994



Technical Information TI00038C/07/EN



**Cleanfit Control CYC25**

- Converts electrical signals into pneumatic signals to control pneumatically-operated retractable assemblies or pumps in conjunction with Liquiline CM44x
- Wide range of control options
- Product Configurator on the product page: [www.endress.com/cyc25](http://www.endress.com/cyc25)



Technical Information TI01231C

**Liquiline Control CDC90**

- Fully automatic cleaning and calibration system for pH and ORP measuring points in all industries
- Cleaned, validated, calibrated and adjusted
- Product Configurator on the product page: [www.endress.com/cdc90](http://www.endress.com/cdc90)



Technical Information TI01340C

### 10.3 Installation material for rinse connections

**Kit, water filter**

- Water filter (dirt trap) 100 µm, complete, incl. angle bracket
- Order No. 71390988

**Pressure reducer kit**

- Complete, incl. manometer and angle bracket
- Order No. 71390993

**Hose connection set G<sup>1</sup>/<sub>4</sub>, DN 12**

- 1.4404 (AISI 316L) 2 x
- Order No. 51502808

**Hose connection set G<sup>1</sup>/<sub>4</sub>, DN 12**

- PVDF (2 x)
- Order No. 50090491

## 11 Technical data

### 11.1 Mounting

Sensor selection	Short version	Gel sensors, ISFET	225 mm
		KCl sensors	225 mm
	Long version	Gel sensors, ISFET	225 mm
		Gel sensors, ISFET KCl sensors	360 mm 360 mm

Special mounting instructions

#### Limit position switches

Switching element function:	NAMUR NC contact (inductive)
Switching distance:	1.5 mm (0.06 ")
Nominal voltage:	8 V
Switching frequency:	0 to 5000 Hz
Housing material:	Stainless steel
Output interface terminals	NAMUR
Limit position switches (inductive conductivity sensors)	Pepperl+Fuchs NJ1.5-6.5-15-N-Y180094

### 11.2 Environment

Ambient temperature -10 to +70 °C (+10 to +160 °F)

Storage temperature -10 to +70 °C (+10 to +160 °F)

### 11.3 Process

Process temperature -10 to 140 °C (14 to 284 °F)

Process pressure range	Pneumatic drive	16 bar (232 psi) up to 140 °C (284 °F)
	Manual drive (PP version may vary)	8 bar (116 psi) to 140 °C (284 °F)

 The service life of the seals is reduced if process temperatures are constantly high or if SIP is used. The other process conditions may also reduce the service life of the seals.

Pressure-temperature ratings

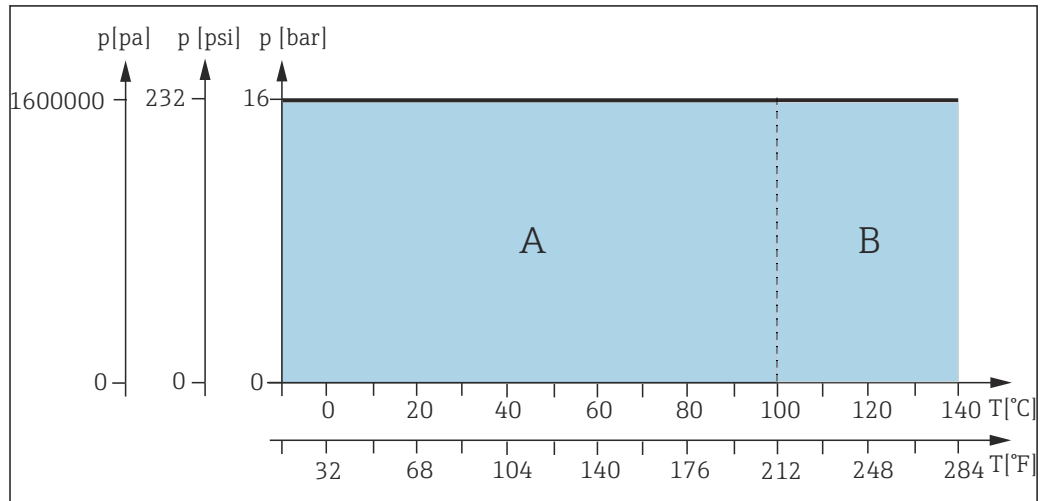

A0042816

61 Pressure-temperature ratings for pneumatic drive

- A Dynamic range
- B Static range

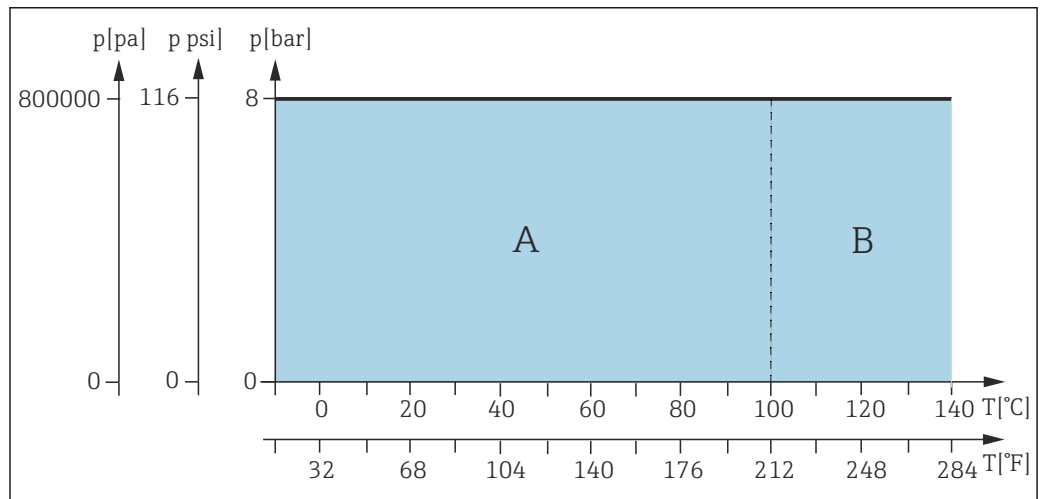

A0042815

62 Pressure-temperature ratings for manual drive

- A Dynamic range
- B Static range

**Manual and pneumatic drive, insertion/retraction up to 6 bar**

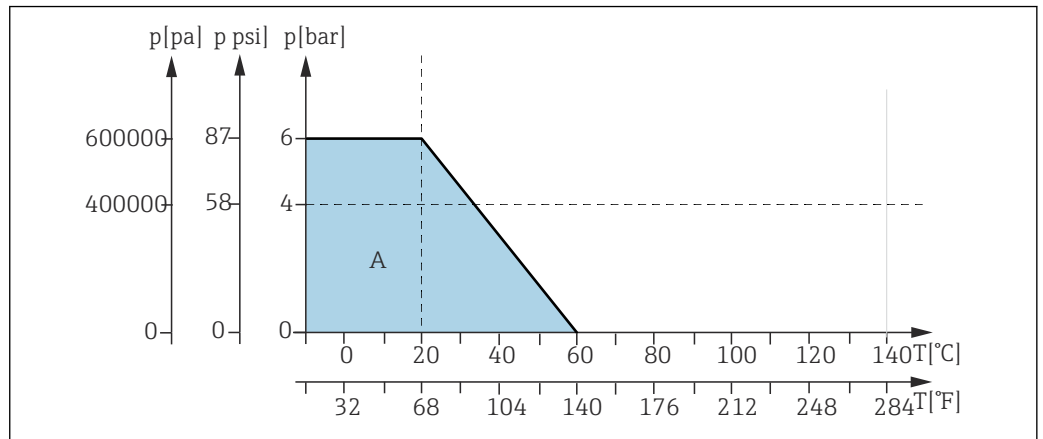

A0042959

63 Pressure/temperature ratings for basic version for the material PP (CPA871\-\*H\*)

A Basic version

## 11.4 Mechanical construction

Design, dimensions → Section "Installation"

Rinse chamber volume	Volume cm <sup>3</sup> (in <sup>3</sup> )(max.)	Volume cm <sup>3</sup> (in <sup>3</sup> )(min.)
Single chamber, short stroke	20.94 (1.28)	10.51 (0.64)
Single chamber, long stroke	42.97 (2.62)	20.77 (1.27)
Double chamber (front)	18.53 (1.13)	9.80 (0.6)
Double chamber (rear)	77.49 (4.72)	47.04 (2.87)
Double chamber (total)	96.02 (5.87)	56.84 (3.47)

Weight Depends on version:  
 Pneumatic drive: 3.8 to 6 kg (8.4 to 13.2 lbs) depending on version  
 Manual drive: 3 to 4.5 kg (6.6 to 9.9 lbs) depending on version

Materials		In contact with medium
Seals:		EPDM-FDA (USP Class VI) / FKM-FDA (USP Class VI) / FFKM-FDA (USP Class VI)
Immersion tube:		Stainless steel 1.4435 (AISI 316L) Ra < 0.76 / Ra < 0.38
Process connection, service chamber		Stainless steel 1.4435 (AISI 316L) Ra < 0.76
Rinse connections:		Stainless steel 1.4435 (AISI 316L)

Not in contact with medium	
Manual drive:	Stainless steel 1.4301 (AISI 304) or 1.4404 (AISI 316L), plastics PPS CF15, PBT, PP
Pneumatic drive:	Stainless steel 1.4301 (AISI 304) or 1.4404 (AISI 316L), plastics PBT, PP

Rinse connections	Option	Description
	Pipe 6/8mm ID/OD	Pipe DIN 11866 series A 8 x 1 hygiene class H4 Internal diameter 6 mm (0.24 in) Outer diameter 8 mm (0.31 in) Ra ≤ 0.38
	G1/4 female	Female thread DIN EN ISO 228 G1/4" Pipe internal diameter 6 mm (0.24 in) Surface (excluding thread): Ra ≤ 0.38
	NPT1/4 female	Female thread ASME B 1.20.1 – 1983 1/4" NPT Pipe internal diameter 6 mm (0.24 in) Surface (excluding thread): Ra ≤ 0.38

Option	Description
Clamp D6/D25	Clamp nozzle DIN32676 Pipe internal diameter 6 mm (0.24 in) Outer diameter, clamp 25 mm Ra ≤ 0.4
BioConnect DN6	Neumo BioConnect DN6 with male thread M16 x 1.5 with pipe connection according to DIN11866 8x1 Pipe internal diameter 6 mm (0.24 in) Pipe outer diameter 8 mm (0.31 in) Ra ≤ 0.8

Surface finish may vary depending on the manufacturing process.

## Index

### A

Accessories . . . . . 60

### C

Cleaning . . . . . 46

Cleaning agent . . . . . 44

Cleaning process seal . . . . . 42

Connection

    Pneumatics . . . . . 28

### D

Dimensions . . . . . 13

Disposal . . . . . 59

### F

Failure of compressed air supply . . . . . 42

### I

Immersion depths . . . . . 20

Incoming acceptance . . . . . 9

Installation . . . . . 24

Installation conditions . . . . . 11

Intended use . . . . . 5

### L

Limit position switches . . . . . 32

### M

Maintenance . . . . . 43

Maintenance intervals . . . . . 43

Maintenance schedule . . . . . 43

Manual operation . . . . . 41

Measuring system . . . . . 24

Mounting . . . . . 11

Mounting requirements . . . . . 11

### N

Nameplate . . . . . 10

### O

O-rings . . . . . 48

Operating . . . . . 40

Operation

    Manual . . . . . 41

    Pneumatic . . . . . 41

### P

Pneumatic connection . . . . . 28

Pneumatic operation . . . . . 41

Post-installation check . . . . . 38

Product identification . . . . . 9

### R

Repair . . . . . 58

Return . . . . . 58

Rinse connections . . . . . 30, 70

### S

Safety information . . . . . 4

Safety instructions . . . . . 5

Scope of delivery . . . . . 9

Seals . . . . . 48

Sensor installation . . . . . 34

Spare parts . . . . . 58

Symbols . . . . . 4

### T

Technical data . . . . . 67

### U

Use . . . . . 5











[www.addresses.endress.com](http://www.addresses.endress.com)

---