

Technical Information

Liquiline System CA80SI

Colorimetric analyzer for silica



Integrated controller with up to 6 measuring channels and digital Memosens technology

Application

The Liquiline System CA80SI is a wet-chemical analyzer for almost continuous determination of the concentration of silica in ultrapure water and boiler feedwater.

The analyzer is designed for use in the following applications:

- Ultrapure water
- Boiler feedwater
- Steam and condensate analysis
- Reverse osmosis
- Desalination systems

Your benefits

- Easy upgrade to measuring station by connecting up to 4 Memosens sensors
- Digital fieldbuses (e.g. PROFINET, PROFIBUS DP, Modbus TCP, Modbus RS485 and Ethernet IP) and web server
- Simple, tool-free maintenance
- Available with up to 6 measuring channels

Table of contents

Function and system design	4	Cable specification	16
Colorimetric measuring principle	4	Connecting optional modules	16
Photometric determination of silica	4	Sensor connection (optional)	19
Cross-sensitivity	4		
Measuring system	4	Performance characteristics	19
		Maximum measured error	19
Device architecture	6	Maximum measurement error for sensor inputs	19
Function diagram	6	Maximum measurement error for current inputs and outputs	19
Slot and port assignment	7	LOD (limit of detection)	19
		Repeatability	19
Communication and data processing	7	Repeatability of sensor inputs	19
		Measuring interval	19
Dependability	7	Number of measuring channels	19
Reliability thanks to Memosens technology	7	Sample requirement	19
Ease of maintenance	8	Reagent requirement	20
Self-monitoring functions	10	Standard requirement	20
Data security	10	Calibration interval	20
IT security	10	Maintenance interval	20
		Maintenance effort	20
Input	10	Mounting	20
Measured variables	10	Mounting location	20
Measuring range	10	Installation instructions	20
Types of input	10		
Input signal	10	Environment	21
Current input, passive	10	Ambient temperature range	21
Cable specification (for optional sensors with Memosens technology)	10	Storage temperature	21
		Relative humidity	21
Output	11	Degree of protection	21
Output signal	11	Electromagnetic compatibility	21
Signal on alarm	12	Electrical safety	22
Load	12	Pollution degree	22
Transmission behavior	12		
		Process	22
Current outputs, active	12	Sample temperature	22
Span	12	Process pressure	22
Signal characteristic	12	Sample flow rate	22
Electrical specification	12	Consistency of the sample	22
Cable specification	12		
		Mechanical construction	22
Relay outputs	12	Dimensions	22
Electrical specification	12	Weight	24
		Materials	24
Protocol-specific data	13	Process connection	25
PROFIBUS DP	13	Hose entries	25
Modbus RS485	13		
Modbus TCP	14	Operability	25
Web server	14	Operation concept	25
EtherNet/IP	14	Display	26
PROFINET	15	Remote operation	26
		Language packages	27
Power supply	15		
Supply voltage	15	Certificates and approvals	28
Fieldbus connection	15		
Power consumption	16		
Cable entries	16		

Order information	28
Product page	28
Product Configurator	28
Scope of delivery	28
Accessories	29
Device-specific accessories	29
Communication-specific accessories	32
System components	33

Function and system design

Colorimetric measuring principle

After sample preparation, some of the permeate is pumped into the mixing/reaction chamber. The specific color reagent is metered exactly in a defined mixture ratio. The chemical reaction causes the characteristic change in the color of the sample. The multispectral photometer determines the level of absorption by the sample at defined wavelengths. The analyzed wavelengths, and their relationships to one another, are parameter-specific.

Based on proportionality the amount of light absorption is a direct indicator of the concentration of the parameter under analysis in the sample. In order to compensate for any interference influences, a reference measurement is performed before the actual measurement. This reference signal is subtracted from the measuring signal. The temperature in the photometer is kept constant to ensure a reproducible reaction that takes place within a short period of time.

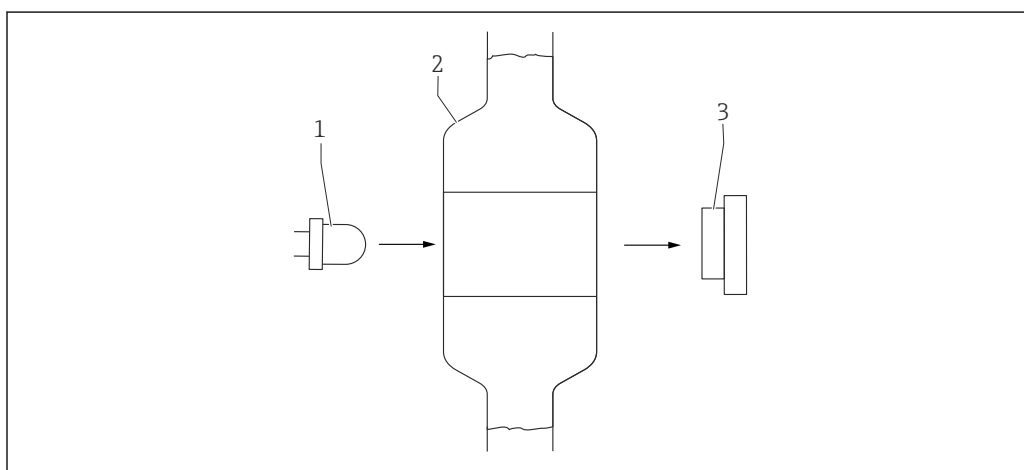

A0022399

1 Colorimetric measuring principle

- 1 Multispectral LED unit (for measurement/reference)
- 2 Cuvette - mixing and reaction vessel
- 3 Detector (for measurement/reference)

Photometric determination of silica

Heteropoly blue method

Silicate and phosphate react in the acidic medium with molybdate to form yellow silicomolybdic acid and phosphomolybdic acid complexes. The addition of citric acid causes the phosphate complex to be destroyed. In the final step, an amino acid is added which reduces the yellow silicomolybdic acid to an intensely blue-colored silicomolybdic blue. The subsequent absorption measurement is directly proportional to the concentration of silica in the sample.

Cross-sensitivity

The ions listed were checked with the specified concentrations. A summary effect has not been studied. No cross-sensitivities were observed up to the concentration levels indicated.

Up to 2000 mg/l (ppm)	Salt NaCl
Up to 25°dH	Hardness CaCl ₂
Up to 10 mg/l (ppm), measurement error < 4 ug/l (ppb)	PO ₄
CA80SI-**AH*: 0.5 to 200 µg/l (ppb)	4 < pH < 12
CA80SI-**AJ*: 50 to 5 000 µg/l (ppb)	5 < pH < 12

Measuring system

A complete measuring system comprises:

- Analyzer Liquiline System CA80SI with the configuration ordered
- Reagents and standard solution (to be ordered separately)
- Filter and pressure relief valve (enclosed separately with angle brackets in 1-/2-channel version, mounted on panel in 4-/6-channel version)
- Panel for sample channel switching: 4 /6 sample inlets (4-/6-channel version)

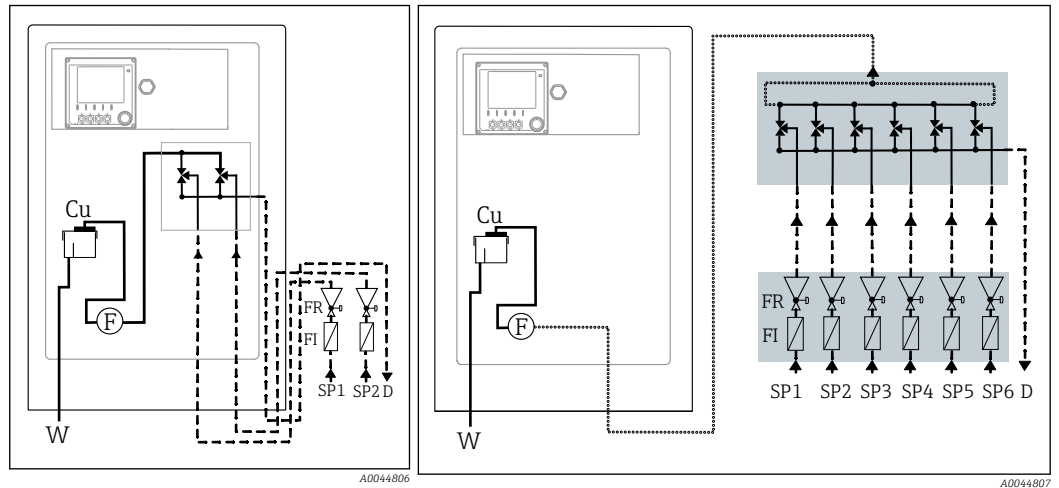

2 1-/2-channel version: Measuring system with upstream pressure relief valves and filters

3 4-/6-channel version: Measuring system with upstream pressure relief valves and filters on panel and external sample channel switching on panel

Cu Overflow cuvette
 D Sample outlet
 F Flow sensor
 FI Filter

FR Pressure relief valve
 SPx Sample inlets, x = 1 to n
 W Outlet

Device architecture

Function diagram

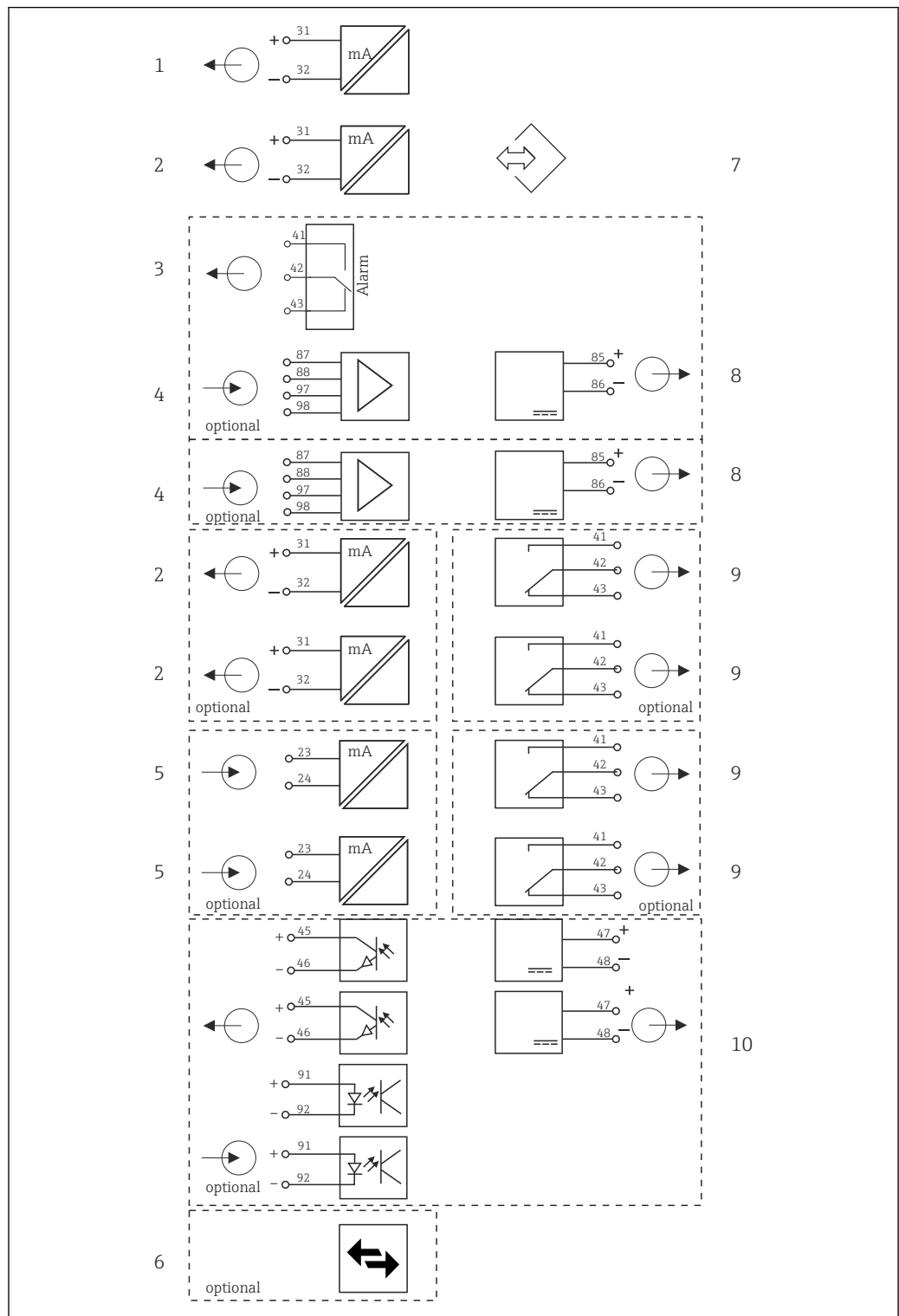

A0021099

4 Block diagram CA80

1 Current output 1:1

2 Current outputs

3 Alarm relay

4 2 x Memosens input (1 x optional)

5 2 x current input (optional)

6 Modbus/Ethernet (optional)

7 Service interface

8 Power supply, fixed cable sensors

9 2 or 4 x relays (optional)

10 2 digital inputs and outputs (optional)

Slot and port assignment

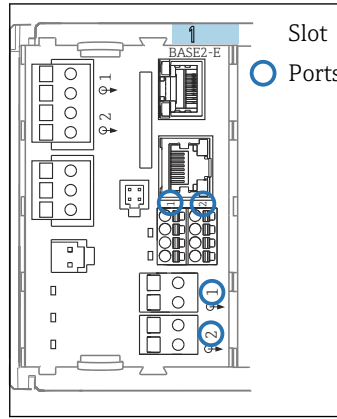

5 Slot and port assignment

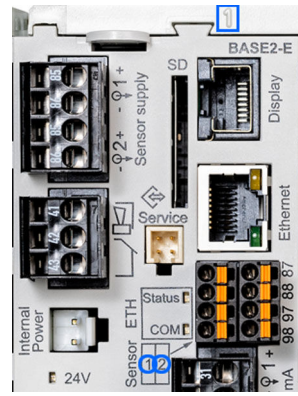

6 Slot and port assignment

Analyzer_C8024A05G00

▶ Heartbeat diagnostics

SP1 Analyzer*	Slot	Port
CH1: 1:1 pH Glass	1	1
CH2: 1:2 Cond e	1	2
Current output 1:1	1	1
Current output 1:2	1	2
Current output 4:1	4	1
Current output 4:2	4	2

ATC 6.95 pH
ATC 131.1 µS/cm
22.5 mA
22.5 mA
22.5 mA

A0040671

7 Slots and ports on the display

* Analyzer measured value (parameter-specific)

- Inputs are assigned to measuring channels in the ascending order of the slots and ports. In the example above:
"CH1: 1:1 pH glass" means:
Channel 1 (CH1) is slot 1 (basic module) : Port 1 (input 1), pH glass sensor
- Outputs and relays are named according to their function, e.g. "current output", and are displayed in ascending order with the slot and port numbers
- Display shows SP1: analyzer measuring channel 1 with sampling point SP1 (measured value display is parameter-specific; is not illustrated in the example)

Communication and data processing

Communication protocols:

- Fieldbus systems
 - PROFIBUS DP (Profile 3.02)
 - Modbus TCP or RS485
 - PROFINET
 - EtherNet/IP
- Configuration via Ethernet

Extension module 485DP/485MB and current outputs

For PROFIBUS DP and Modbus RS485 communication protocols:
A maximum of 2 current outputs can be used in parallel.

Ethernet functionality via Base2 module and current outputs

A maximum of 6 current outputs can be used in parallel.

Bus termination on the device

- Via slide switch at bus module 485DP/485MB
- Displayed via LED "T" on bus module 485DP/485MB

Dependability

Reliability thanks to Memosens technology

Memosens

Memosens makes your measuring point safer and more reliable:

- Non-contact, digital signal transmission enables optimum galvanic isolation
- Completely watertight
- Sensor can be calibrated in a lab, thus increasing the availability of the measuring point in the process
- Intrinsically safe electronics mean operation in hazardous areas is not a problem.
- Predictive maintenance thanks to recording of sensor data, e.g.:
 - Total hours of operation
 - Hours of operation with very high or very low measured values
 - Hours of operation at high temperatures
 - Number of steam sterilizations
 - Sensor condition

Ease of maintenance**Modular design**

The modular analyzer can be easily adapted to suit your needs:

- Retrofit extension modules for new or extended range of functions, e.g. current outputs, relays and digital communication
- Upgrade to measuring station with digital sensors with Memosens technology
- Optional: M12 sensor connector for connecting any kind of Memosens sensor

Data storage

- Independent, integrated ring memories (FIFO) or stack memories for recording:
 - An analog value (e.g. flow, pH value, conductivity)
 - Events (e.g. power failure)
- Analyzer data logbook
 - Scan time: automatically adjusted to the measuring interval
 - Max. 6 data logbooks
 - 20 000 entries per logbook
 - Graphic display (load curves) or numerical list
 - Factory setting: enabled for all channels, ring memory (FIFO)
- Data logbooks for digital sensors:
 - Adjustable scan time: 1 to 3600 s (1 h)
 - Max. 8 data logbooks
 - 150,000 entries per logbook
 - Graphic display (load curves) or numerical list
- Calibration logbook: max. 75 entries
- Hardware logbook:
 - Hardware configuration and modifications
 - Max. 125 entries
- Version logbook:
 - Software updates among other things
 - Max. 50 entries
- Event logbook
- Analyzer event logbook
 - Analyzer-specific events
 - Max. 19 500 entries, ring memory or fill-up buffer for recording
- Operations logbook: max. 250 entries
- Diagnostic logbook: max. 250 entries

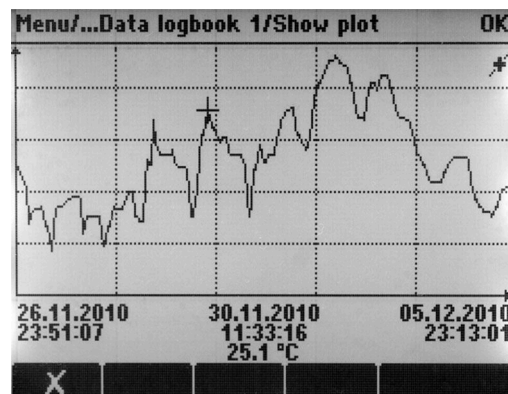

 8 Data logbook: graphic representation on the display

A0024359

Mathematical functions (virtual process values)

In addition to "real" process values, which are provided by connected physical sensors or analog inputs, mathematical functions can be used to calculate a maximum of 6 "virtual" process values.

The "virtual" process values can be:

- Output via a current output or a fieldbus
- Used as a controlled variable
- Assigned as a measured variable to a limit switch
- Used as a measured variable to trigger cleaning
- Displayed in user-defined measuring menus

The following mathematical functions are possible:

- Calculation of pH from two conductivity values according to VGB Standard 405, e.g. in boiler feedwater
- Difference between two measured values from different sources, e.g. to monitor membranes
- Differential conductivity, e.g. to monitor the efficiency of ion exchangers
- Degassed conductivity, e.g. for process controls in power plants
- Redundancy to monitor two or three redundant sensors
- rH calculation based on the measured values of a pH and an ORP sensor
- Formula editor as a powerful mathematics tool and for Boolean operations with up to 3 measured values

FieldCare

Configuration and asset management software based on FDT/DTM technology

- Complete device configuration when connected via FXA291 and service interface
- Access to a number of configuration parameters and identification, measuring and diagnostic data when connected via HART modem
- Logbooks can be downloaded in CSV format or binary format for "Field Data Manager" software

Field Data Manager

Visualization software and database for measuring, calibration and configuration data

- SQL database which is protected against manipulation
- Functions to import, save and print out logbooks
- Load curves to display measured values

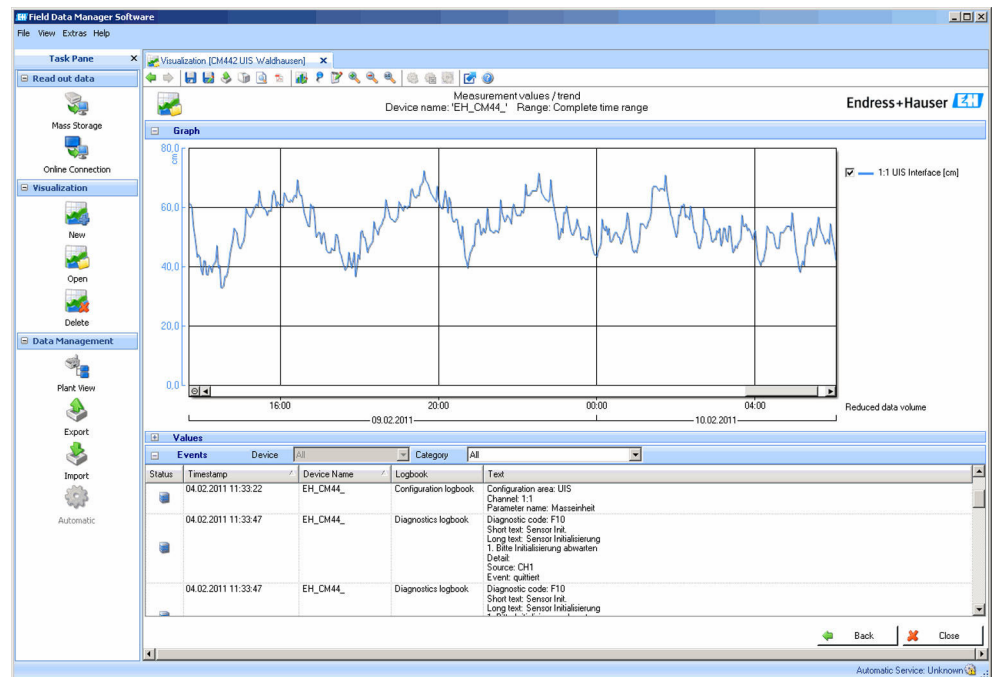

9 Field Data Manager: load curve display

A0016009

SD card

The exchangeable storage medium enables:

- Quick and easy software updates and upgrades
- Quick and easy updates and upgrades to measuring parameter lists
- Data storage of internal device memory (e.g. logbooks)
- Transfer of complete configurations to a device with an identical setup (backup function)
- Transfer of configurations without the TAG and bus address to devices with an identical setup (copy function)

Endress+Hauser offers industry-approved SD cards as accessories. These memory cards provide maximum data security and integrity.

Other SD cards can also be used. However, Endress+Hauser does not accept any responsibility for the data security of such cards.

Self-monitoring functions	<p>Electronics</p> <ul style="list-style-type: none"> ▪ Current inputs are deactivated in the event of overcurrent and reactivated once the overcurrent stops. ▪ Board voltages are monitored and the board temperature is also measured. <p>Counter</p> <p>Counters monitor consumables such as reagents or dispensers.</p> <p>Photometer</p> <ul style="list-style-type: none"> ▪ Automatic temperature monitoring ▪ Active monitoring of communication between the photometer module and the analyzer electronics ▪ Leak sensor in the housing ▪ Flow monitoring
Data security	All settings, logbooks etc. are stored in a non-volatile memory to ensure that the data are retained even in the event of a disruption to the power supply.
IT security	<p>We only provide a warranty if the device is installed and used as described in the Operating Instructions. The device is equipped with security mechanisms to protect it against any inadvertent changes to the device settings.</p> <p>IT security measures in line with operators' security standards and designed to provide additional protection for the device and device data transfer must be implemented by the operators themselves.</p>

Input

Measured variables	SiO ₂ [mg/l, µg/l, ppm, ppb]				
Measuring range	<table border="0"> <tr> <td>CA80SI-**AH*:</td> <td>0 to 500 µg/l (ppb)</td> </tr> <tr> <td>CA80SI-**AJ*:</td> <td>50 to 5 000 µg/l (ppb)</td> </tr> </table>	CA80SI-**AH*:	0 to 500 µg/l (ppb)	CA80SI-**AJ*:	50 to 5 000 µg/l (ppb)
CA80SI-**AH*:	0 to 500 µg/l (ppb)				
CA80SI-**AJ*:	50 to 5 000 µg/l (ppb)				
Types of input	<ul style="list-style-type: none"> ▪ 1, 2, 4 or 6 measuring channels (analyzer main parameter) ▪ 1 to 4 digital sensor inputs for sensors with Memosens protocol (optional) ▪ Analog current inputs (optional) ▪ Binary inputs (optional) 				
Input signal	Depending on version 2 x 0/4 to 20 mA (optional), passive, potentially isolated				
Current input, passive	<p>Span > 0 to 20 mA</p> <p>Signal characteristic Linear</p> <p>Internal resistance Non-linear</p> <p>Test voltage 500 V</p>				
Cable specification (for optional sensors with Memosens technology)	<p>Cable type Memosens data cable CYK10 or sensor fixed cable, each with cable end sleeves or M12 round-pin connector (optional)</p> <p>Cable length Max. 100 m (330 ft)</p>				

Output

Output signal

Depending on version:

- 2 x 0/4 to 20 mA, active, potentially isolated (standard version)
- 4 x 0/4 to 20 mA, active, potentially isolated (version with 2 additional analog outputs)
- 6 x 0/4 to 20 mA, active, potentially isolated (version with 4 additional analog outputs)
- Binary outputs

PROFIBUS DP/RS485	
Signal encoding	EIA/TIA-485, PROFIBUS DP-compliant acc. to IEC 61158
Data transmission rate	9.6 kBd, 19.2 kBd, 45.45kBd, 93.75 kBd, 187.5 kBd, 500 kBd, 1.5 MBd, 6 MBd, 12 MBd
Galvanic isolation	Yes
Connectors	Spring terminal (max. 1.5 mm), bridged internally (T-function), optional M12
Bus termination	Internal slide switch with LED display

Modbus RS485	
Signal encoding	EIA/TIA-485
Data transmission rate	2,400, 4,800, 9,600, 19,200, 38,400, 57,600 and 115,200 baud
Galvanic isolation	Yes
Bus termination	Internal slide switch with LED display

Web server and Modbus TCP	
Signal encoding	IEEE 802.3 (Ethernet)
Data transmission rate	10 / 100 MBd
Galvanic isolation	Yes
Connection	RJ45, M12 optional
IP address	DHCP or configuration using menu

EtherNet/IP	
Signal encoding	IEEE 802.3 (Ethernet)
Data transmission rate	10 / 100 MBd
Galvanic isolation	Yes
Connection	RJ45, M12 optional (D-encoded)
IP address	DHCP (default) or configuration via menu

PROFINET	
Signal encoding	IEEE 802.3 (Ethernet)
Data transmission rate	100 MBd
Galvanic isolation	Yes
Connection	RJ45
Name of station	Via DCP protocol using the configuration tool (e.g. Siemens PRONETA)
IP address	Via DCP protocol using the configuration tool (e.g. Siemens PRONETA)

Signal on alarm	Adjustable, as per NAMUR Recommendation NE 43 <ul style="list-style-type: none"> ▪ In measuring range 0 to 20 mA: Failure current from 0 to 23 mA ▪ In measuring range 4 to 20 mA: Failure current from 2.4 to 23 mA ▪ Factory setting for failure current for both measuring ranges: 21.5 mA
------------------------	--

Load	Max. 500 Ω
-------------	-------------------

Transmission behavior	Linear
------------------------------	--------

Current outputs, active

Span	0 to 23 mA
-------------	------------

Signal characteristic	Linear
------------------------------	--------

Electrical specification	Output voltage Max. 24 V Test voltage 500 V
---------------------------------	--

Cable specification	Cable type Recommended: shielded cable Cable specification Max. 2.5 mm ² (14 AWG)
----------------------------	---

Relay outputs

Electrical specification	Relay types <ul style="list-style-type: none"> ▪ 1 single-pin changeover contact (alarm relay) ▪ 2 or 4 single-pin changeover contacts (optional with extension modules) Maximum load <ul style="list-style-type: none"> ▪ Alarm relay: 0.5 A ▪ All other relays: 2.0 A Relay switching capacity
---------------------------------	---

Base module (Alarm relay)

Switching voltage	Load (max.)	Switching cycles (min.)
230 V AC, $\cos\Phi = 0.8$ to 1	0.1 A	700,000
	0.5 A	450,000
115 V AC, $\cos\Phi = 0.8$ to 1	0.1 A	1,000,000
	0.5 A	650,000
24 V DC, L/R = 0 to 1 ms	0.1 A	500,000
	0.5 A	350,000

Extension module

Switching voltage	Load (max.)	Switching cycles (min.)
230 V AC, $\cos\Phi = 0.8$ to 1	0.1 A	700,000
	0.5 A	450,000
	2 A	120,000
115 V AC, $\cos\Phi = 0.8$ to 1	0.1 A	1,000,000
	0.5 A	650,000
	2 A	170,000
24 V DC, L/R = 0 to 1 ms	0.1 A	500,000
	0.5 A	350,000
	2 A	150,000

Minimum load (typical)

- Min. 100 mA at 5 V DC
- Min. 1 mA at 24 V DC
- Min. 5 mA at 24 V AC
- Min. 1 mA at 230 V AC

Protocol-specific data

PROFIBUS DP	
Manufacturer ID	11 _h
Device type	155E _h
Profile version	3.02
Device database files (GSD files)	www.endress.com/profibus Device Integration Manager DIM
Output variables	16 AI blocks, 8 DI blocks
Input variables	4 AO blocks, 8 DO blocks
Supported features	<ul style="list-style-type: none"> ▪ 1 MSCY0 connection (cyclical communication, master class 1 to slave) ▪ 1 MSAC1 connection (acyclical communication, master class 1 to slave) ▪ 2 MSAC2 connections (acyclical communication, master class 2 to slave) ▪ Device lock: The device can be locked using the hardware or software. ▪ Addressing using DIL switches or software ▪ GSD, PDM DD, DTM

Modbus RS485	
Protocol	RTU/ASCII
Function codes	03, 04, 06, 08, 16, 23
Broadcast support for function codes	06, 16, 23
Output data	16 measured values (value, unit, status), 8 digital values (value, status)
Input data	4 setpoints (value, unit, status), 8 digital values (value, status), diagnostic information
Supported features	Address can be configured using switch or software

Modbus TCP

TCP port	502
TCP connections	3
Protocol	TCP
Function codes	03, 04, 06, 08, 16, 23
Broadcast support for function codes	06, 16, 23
Output data	16 measured values (value, unit, status), 8 digital values (value, status)
Input data	4 setpoints (value, unit, status), 8 digital values (value, status), diagnostic information
Supported features	Address can be configured using DHCP or software

Web server

The web server enables full access to the device configuration, measured values, diagnostic messages, logbooks and service data via standard WiFi/WLAN/LAN/GSM or 3G routers with a user-defined IP address.

TCP port	80
Supported features	<ul style="list-style-type: none"> ▪ Remote-controlled device configuration(1 session) ▪ Save/restore device configuration (via SD card) ▪ Logbook export (file formats: CSV, FDM) ▪ Access to web server via DTM or Internet Explorer ▪ Login ▪ Web server can be switched off

EtherNet/IP

Log	EtherNet/IP	
ODVA certification	Yes	
Device profile	Generic device (product type: 0x2B)	
Manufacturer ID	0x049E _h	
Device type ID	0x109F	
Polarity	Auto-MIDI-X	
Connections	CIP	12
	I/O	6
	Explicit message	6
	Multicast	3 consumers
Minimum RPI	100 ms (default)	
Maximum RPI	10000 ms	
System integration	EtherNet/IP	EDS
	Rockwell	Add-on-Profile Level 3, Faceplate for Factory Talk SE
IO data	Input (T → O)	Device status and diagnostic message with highest priority Measured values: <ul style="list-style-type: none"> ▪ 16 AI (analog input) + Status + Unit ▪ 8 DI (discrete input) + Status
	Output (O → T)	Actuating values: <ul style="list-style-type: none"> ▪ 4 AO (analog output) + status + unit ▪ 8 DO (discrete output) + Status

PROFINET	Protocol	"Application layer protocol for decentral device periphery and distributed automation", PNIO Version 2.34
	Communication type	100 MBit/s
	Conformance Class	Conformance Class B
	Netload Class	Netload Class II
	Baud rate	Automatic 100 Mbps with full-duplex detection
	Cycle times	From 32 ms
	Device profile	Application interface identifier 0xF600 Generic device
	PROFINET interface	1 port, Realtime Class 1 (RT_CLASS_1)
	Manufacturer ID	0x11 _h
	Device type ID	0x859F _h
	Device description files (GSD)	Information and files under: <ul style="list-style-type: none"> ▪ www.endress.com On the product page for the device: Documents/Software → Device drivers ▪ www.profibus.com On the website under Products/Product Finder
	Polarity	Auto-polarity for automatic correction of crossed TxD and RxD pairs
	Supported connections	<ul style="list-style-type: none"> ▪ 1 x AR (IO Controller AR) ▪ 1 x AR (IO-Supervisor Device AR connection allowed) ▪ 1 x Input CR (Communication Relation) ▪ 1 x Output CR (Communication Relation) ▪ 1 x Alarm CR (Communication Relation)
	Configuration options for measuring device	<ul style="list-style-type: none"> ▪ Web browser ▪ Manufacturer-specific software (FieldCare, DeviceCare) ▪ Device master file (GSD), can be read out via the integrated web server of the measuring device
	Configuration of the device name	DCP protocol
Supported functions	<ul style="list-style-type: none"> ▪ Identification & maintenance Simple device identification via: <ul style="list-style-type: none"> ▪ Process control system ▪ Nameplate ▪ Measured value status The process variables are communicated with a measured value status ▪ Blinking feature (FLASH_ONCE) via the local display for simple device identification and assignment ▪ Device operation via operating tools (e.g. FieldCare, DeviceCare) 	
System integration	For information on system integration, see the Operating Instructions <ul style="list-style-type: none"> ▪ Cyclic data transmission ▪ Overview and description of the modules ▪ Status coding ▪ Startup configuration ▪ Factory setting 	

Power supply

Supply voltage

- 100 to 120 V AC / 200 to 240 V AC
- 50 or 60 Hz

Fieldbus connection Supply voltage: not applicable

Power consumption	For a sample flow rate of 80 ml/min (2.7 fl oz/min), a continuous measuring interval (10 minutes), a sample temperature of 25 °C (77 °F), an ambient temperature of 25 °C (77 °F) and a device with a supply voltage of 230 V: <ul style="list-style-type: none"> ■ Typically 60 VA ■ Max. 1250 VA
--------------------------	--

Cable entries	<ul style="list-style-type: none"> ■ 4 x bores for M16, G3/8, NPT3/8", Memosens connection ¹⁾ ■ 4 x bores for M20, G1/2, NPT1/2"
----------------------	---

Cable specification	Cable gland	Permitted cable diameter
	M16x1.5 mm	4 to 8 mm (0.16 to 0.32")
	M12x1.5 mm (for order version M12 socket for Memosens sensors)	2 to 5 mm (0.08 to 0.20")
	M20x1.5 mm	6 to 12 mm (0.24 to 0.48")
	NPT ³ / ₈ "	4 to 8 mm (0.16 to 0.32")
	G ³ / ₈	4 to 8 mm (0.16 to 0.32")
	NPT ¹ / ₂ "	6 to 12 mm (0.24 to 0.48")
	G ¹ / ₂	7 to 12 mm (0.28 to 0.48")

 Cable glands mounted at the factory are tightened with 2 Nm.

Connecting optional modules With extension modules you can purchase additional functions for your device.

NOTICE

Unacceptable hardware combinations (due to conflicts in power supply)

Incorrect measurements or total failure of the measuring point as a result of heat build-up or overloading

- ▶ Find out if the planned upgrade of your device results in a permitted hardware combination (configurator on www.endress.com/CA80SI).
- ▶ A maximum of four sensor inputs is permitted.
- ▶ A maximum of four relay outputs is permitted.
- ▶ A maximum of eight current inputs and six current outputs is permitted.
- ▶ A maximum of two "DIO" modules is permitted.
- ▶ Please contact your Endress+Hauser sales center should you have any questions.

 The number of modules is limited by the number of existing cable bushings.

 Cable bushings and possible cable diameters

1)

Overview of all the optional modules

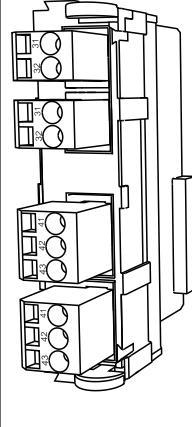
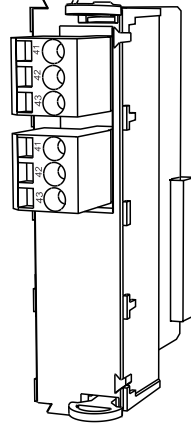
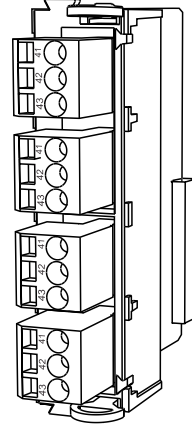
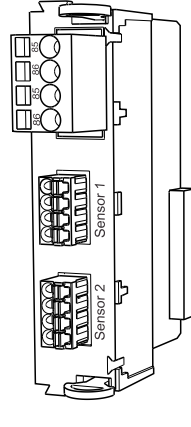
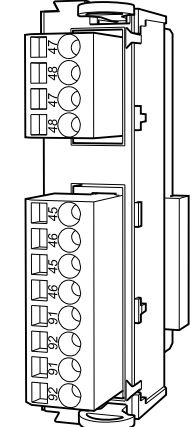
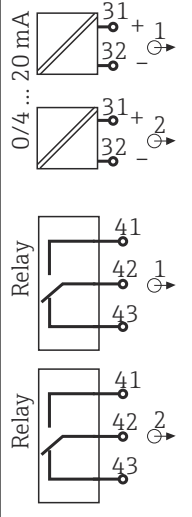
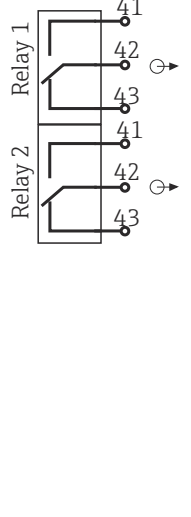
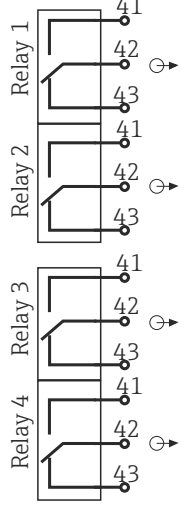
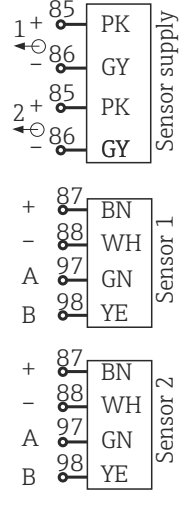
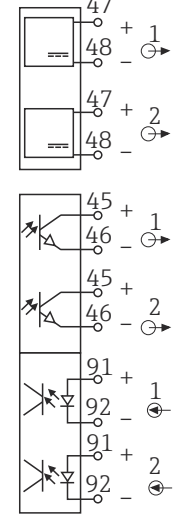
Module name				
AOR	2R	4R	2DS	DIO
				
<ul style="list-style-type: none"> 2 x 0/4 to 20 mA analog outputs 2 relays Order No. 71111053 	<ul style="list-style-type: none"> 2 relays Order No. 71125375 	<ul style="list-style-type: none"> 4 relays Order No. 71125376 	<ul style="list-style-type: none"> 2 digital sensor inputs 2 power supply systems for digital sensors Order No. 71135631 	<ul style="list-style-type: none"> 2 digital inputs 2 digital outputs with auxiliary voltage Order No. 71135638
				

Module name				
2AO	4AO	2AI	485DP	485MB
<ul style="list-style-type: none"> 2 x 0/4 to 20 mA analog outputs Order No. 71135632 	<ul style="list-style-type: none"> 4 x 0/4 to 20 mA analog outputs Order No. 71135633 	<ul style="list-style-type: none"> 2 x 0/4 to 20 mA analog inputs Order No. 71135639 	<ul style="list-style-type: none"> 5V power supply for PROFIBUS DP termination RS485 for PROFIBUS DP Order No. 71575177 	<ul style="list-style-type: none"> RS485 for Modbus Order No. 71575178

i **PROFIBUS DP (module 485DP)**
 Contacts 95, 96 and 99 are jumpered in the plug. This ensures that PROFIBUS communication is not interrupted if the connector is disconnected.

Sensor connection (optional) *Sensors with Memosens protocol*

Sensor types	Sensor cable	Sensors
Digital sensors without additional internal power supply	With plug-in connection and inductive signal transmission	<ul style="list-style-type: none"> ■ pH sensors ■ ORP sensors ■ Combined sensors ■ Oxygen sensors (amperometric and optical) ■ Conductivity sensors with conductive measurement of conductivity ■ Chlorine sensors (disinfection)
	Fixed cable	Conductivity sensors with inductive measurement of conductivity
Digital sensors with additional internal power supply	Fixed cable	<ul style="list-style-type: none"> ■ Turbidity sensors ■ Sensors for interface measurement ■ Sensors for measuring the spectral absorption coefficient (SAC) ■ Nitrate sensors ■ Optical oxygen sensors ■ Ion-sensitive sensors

Performance characteristics

Maximum measured error ²⁾	CA80SI-**AH*:	Concentrations <200 µg/l: ±1.0 µg/l (ppb) or 2 % of reading (typically) Concentrations ≥200 µg/l: 5 % of reading (typically)
	CA80SI-**AJ*:	5 % of reading (typically)

Maximum measurement error for sensor inputs	→ Documentation of the connected sensor
--	---

Maximum measurement error for current inputs and outputs	<p>Typical measured errors:</p> <p>< 20 µA (with current values < 4 mA)</p> <p>< 50 µA (with current values 4 to 20 mA)</p> <p>at 25 °C (77° F) in each case</p> <p>Additional measured error depending on the temperature:</p> <p>< 1.5 µA/K</p>
---	---

LOD (limit of detection)	0.5 µg/l (ppb)
---------------------------------	----------------

Repeatability ²⁾	CA80SI-**AH*:	± 0.5 µg/l (ppb) or ± 1 % of measured value
	CA80SI-**AJ*:	± 1 % of the measured value

Repeatability of sensor inputs	→ Documentation of the connected sensor
---------------------------------------	---

Measuring interval	<ul style="list-style-type: none"> ■ Continuous (approx. 10 min), adjustable ≥ 10 min ■ Factory setting: 20 min
---------------------------	---

Number of measuring channels	1, 2, 4 or 6 measuring channels depending on the order version
-------------------------------------	--

Sample requirement	> 140 ml (4.73 fl oz)/measurement, depending on flow
---------------------------	--

2) According to ISO 15839 with standard solutions. Measurement errors include all the uncertainties of the analyzer. They do not include the uncertainties from the standard solutions used as a reference.

Reagent requirement	<ul style="list-style-type: none"> ■ 200 µl per reagent and measurement ³⁾ for measuring intervals ≥ 15 minutes ■ Given a measuring interval of 20 min, one set of reagents (1000 ml) lasts for approx. 65 days ■ Given a measuring interval of 12 min, one set of reagents (2500 ml) lasts for approx. 100 days
Standard requirement	<ul style="list-style-type: none"> ■ Approx. 140 ml (4.73 fl.oz) / calibration ■ With a 2.5 l (84.5 fl.oz) standard bottle and calibration interval of 96 h approx. 65 days ■ With a 5 l (169 fl.oz) standard bottle and calibration interval of 96 h approx. 130 days
Calibration interval	1 to 99 days, depending on application and ambient conditions
Maintenance interval	Every 3 to 6 months, depending on the application
Maintenance effort	Weekly: visual inspection

Mounting

Mounting location	<p>Note the following when erecting the device:</p> <ul style="list-style-type: none"> ▶ If mounting on a wall, make sure that the wall has sufficient load-bearing capacity and is fully perpendicular. ▶ If mounting on a base, set up the device on a level surface. Installing on a base is only permitted indoors. ▶ Protect the device against additional heating (e.g. from heaters). ▶ Protect the device against mechanical vibrations. ▶ Protect the device against corrosive gases, e.g. hydrogen sulfide (H₂S) and chlorine gases. ▶ Make sure to pay attention to the maximum height difference and the maximum distance from the sampling point. ▶ Ensure that sample outlet hose "D" and outlet hose "W" can drain freely, without any siphoning effects. ▶ Make sure air can circulate freely at the front of the housing. ▶ Open analyzers (i.e. analyzers that are supplied without a door) may only be set up in closed areas or in a protective cabinet or similar facility.
Installation instructions	<p>The device can be installed in the following ways:</p> <ul style="list-style-type: none"> ■ Mounted on a wall ■ Mounted on a base

3) We recommend the large reagent set 3 x 2.5 l + 1 x 5 l for measuring intervals < 15 minutes. We recommend the small reagent set 3 x 1 l + 1 x 2.5 l

Spacing required for installing analyzer

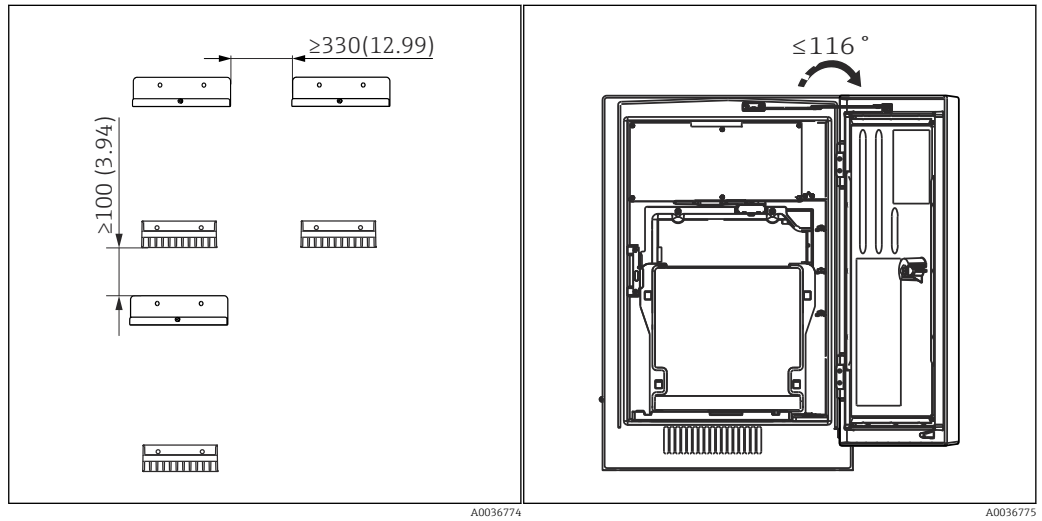

10 Minimum spacing required for mounting. Engineering unit mm (in). 11 Maximum opening angle

Spacing required for installing wall-mount version

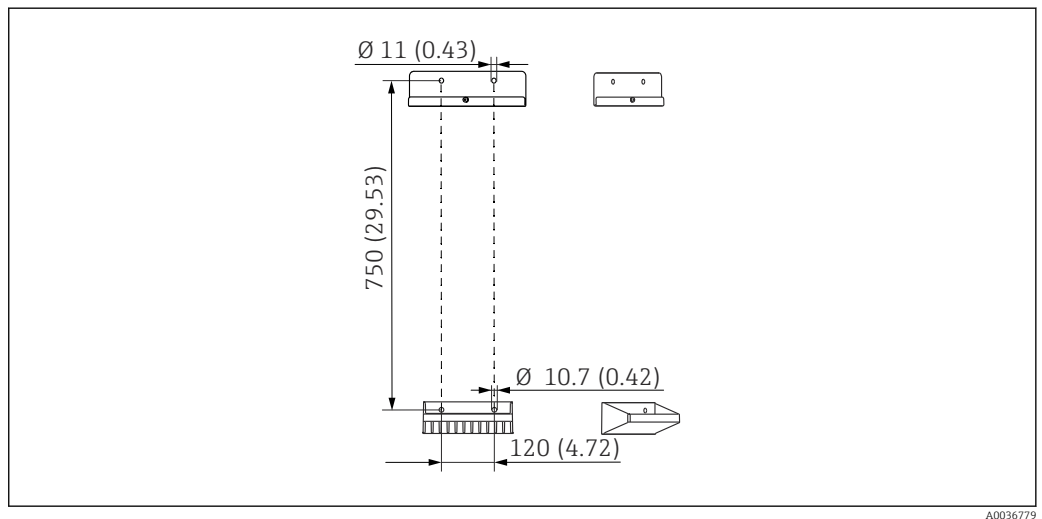

12 Holder unit dimensions. Engineering unit mm (in)

Environment

Ambient temperature range	+5 to +40 °C (41 to 104 °F)
Storage temperature	-20 to 60 °C (-4 to 140 °F)
Relative humidity	10 to 95 %, non-condensing
Degree of protection	IP55 (cabinet, analyzer stand), TYPE 3R (cabinet, analyzer stand)
Electromagnetic compatibility⁴⁾	Interference emission and interference immunity as per EN 61326-1, class A for industrial areas

4) Sufficient mains quality is required to operate the product as intended.

Electrical safety	According to EN/IEC 61010-1:2010, Class I equipment Low voltage: overvoltage category II For installations up to 2000 m (6500 ft) above MSL
--------------------------	---

Pollution degree	Pollution level 2
-------------------------	-------------------

Process

Sample temperature	5 to 45 °C (41 to 113 °F)
---------------------------	---------------------------

Process pressure	1 to 5 bar (14.5 to 72.5 psi) Recommended: 1.5 to 3 bar (21.8 to 43.5 psi)
-------------------------	---

Sample flow rate	60 to 250 ml/min (2.0 to 8.5 fl.oz/min) Recommended: 70 ml/min (2.4 fl.oz/min)
-------------------------	---

Consistency of the sample	Particle-free
----------------------------------	---------------

Mechanical construction

Dimensions

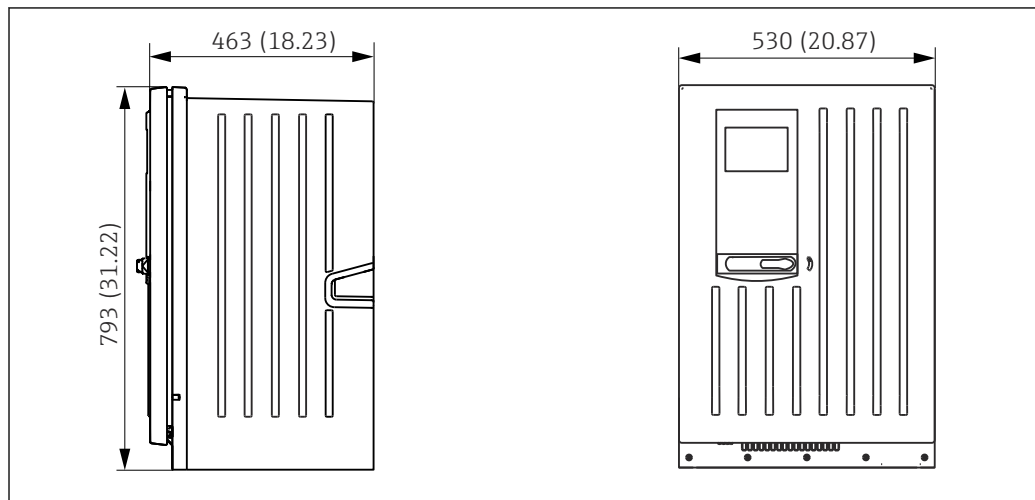

A0028820

13 *Liquiline System CA80 closed version, dimensions in mm (in)*

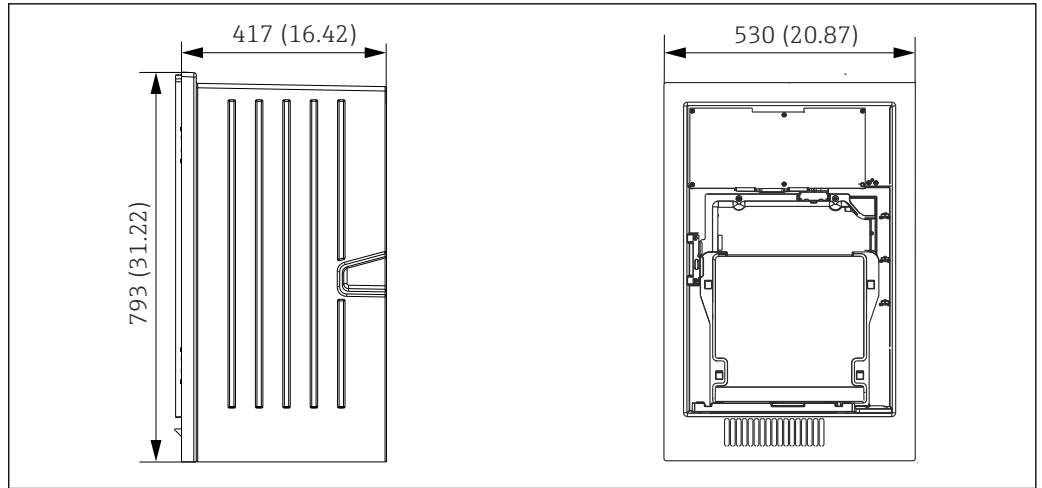

A0030419

14 Liquiline System CA80 open version, dimensions in mm (in)

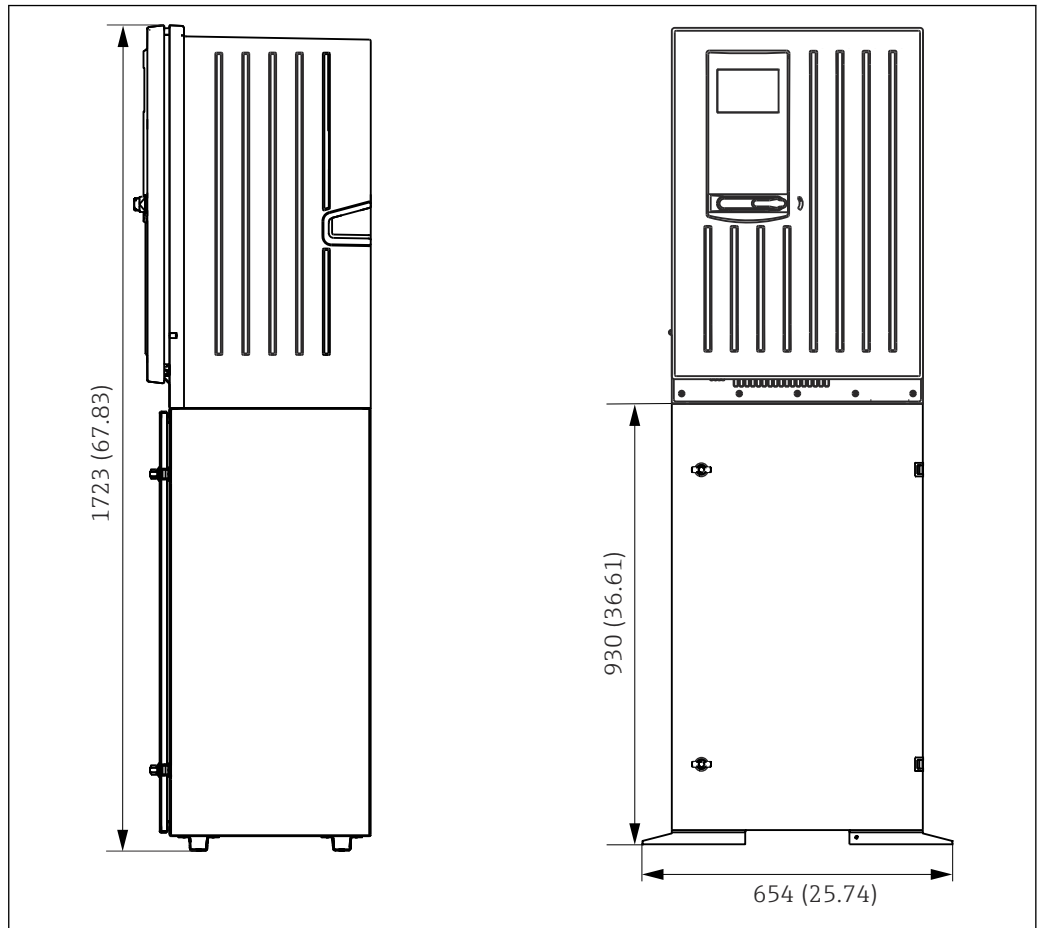

A0028821

15 Liquiline System CA80 with base, dimensions in mm (in)

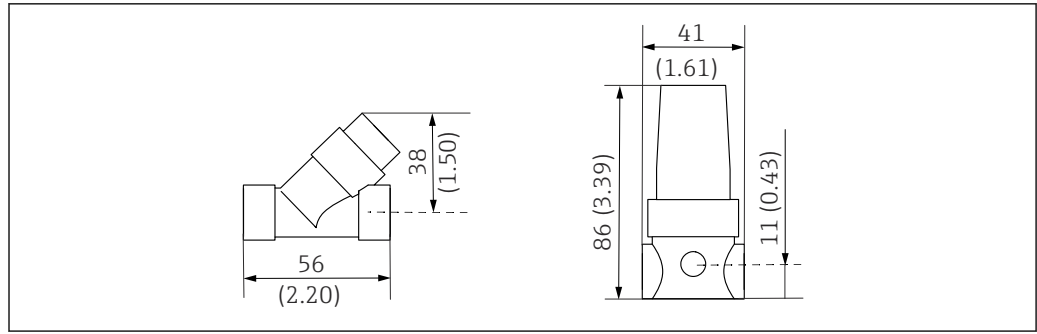

A0036334

16 CA80SI 1-/2-channel version: Filter (left), pressure-reducing valve (right), dimensions in mm (in)

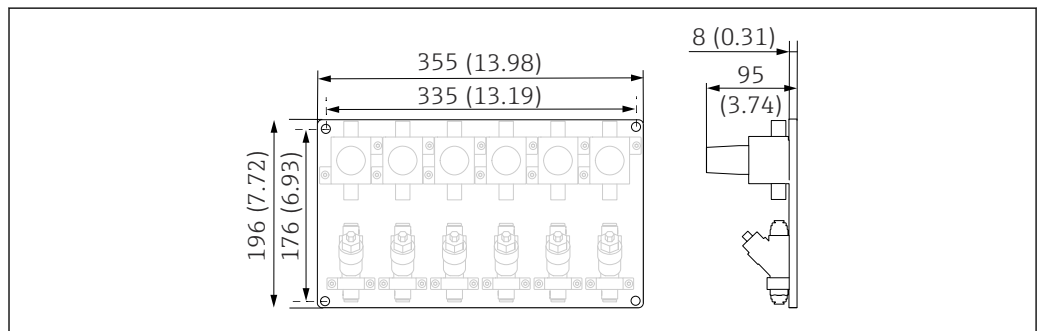

A0036389

17 CA80SI 4-/6-channel version: Panel with pressure-reducing valves and filters, dimensions in mm (in)

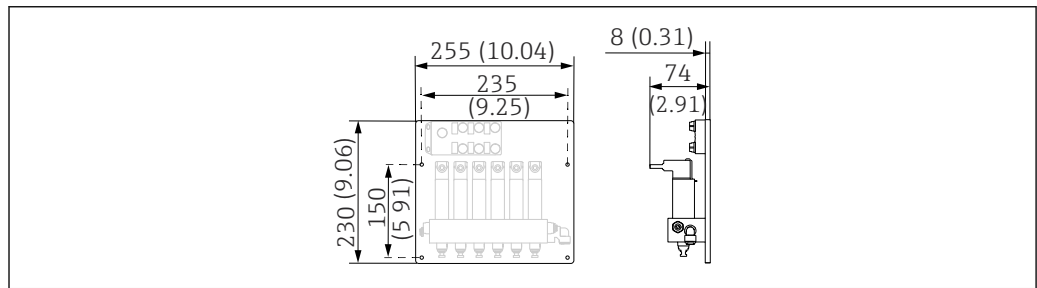

A0036390

18 CA80SI 4-/6-channel version: Panel with sample channel switching, dimensions in mm (in)

Weight

Order

Weight

Cabinet version	40 kg (88.2 lbs)
Open installation	32 kg (70.6 lbs)
Analyzer stand	73 kg (161 lbs)

Materials

Parts not in contact with medium	
Cabinet version, exterior cover	ASA + PC
Open installation, exterior cover	
Cabinet version, interior lining	PP
Open installation, interior lining	
Window	Safety glass, coated
Reagent container	PP
Insulation	EPP (extruded PP)
Base, analyzer stand	Powder-coated sheet steel

Parts in contact with medium	
Pressure relief valve	<ul style="list-style-type: none"> ■ EPDM ■ POM ■ Stainless steel 1.4401
Flow sensor	<ul style="list-style-type: none"> ■ FKM ■ PP ■ PVDF
Filter	<ul style="list-style-type: none"> ■ Stainless steel 1.4408 ■ PTFE
Capillary holder	PC, black
Cuvette	PMMA
Sample channel switching	<ul style="list-style-type: none"> ■ Manifold: PVC ■ Valves: EPDM, PPS
Sample pre-heating (heating coil)	Stainless steel 1.4301
Hoses	<ul style="list-style-type: none"> ■ C-Flex ■ NORPRENE ■ PEEK ■ Polyurethane ■ PTFE ■ PVC
Plug-in connector (John-Guest plug-in connector)	POM

Process connection	Sample inlet:	Plug-in connector for rigid hoses with OD 6 mm
	Sample outlet:	Plug-in connector for rigid hoses with OD 8 mm
	Cuvette outlet:	Hose barb for flexible hoses with ID 13 mm

Hose entries 4 x bores for M32 for sample inflow and outflow

Operability

Operation concept The simple and structured operating concept sets new standards:

- Intuitive operation with the navigator and soft keys
- Fast configuration of application-specific measurement options
- Easy configuration and diagnosis thanks to plain-text display
- All languages that can be ordered are available in every device



19 Easy operation

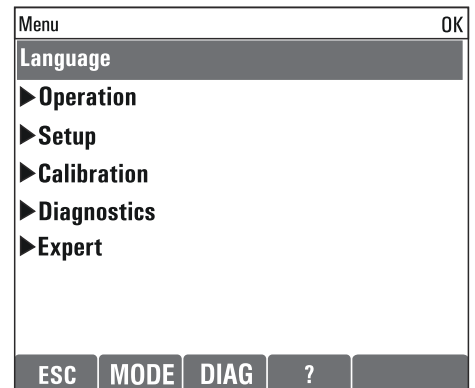

20 Plain-text menu

Display

Graphic display:

- Resolution: 240 x 160 pixel
- Back light with switch-off function
- Red display background for alarms alerts users to errors
- Transflective display technology for maximum contrast even in bright environments

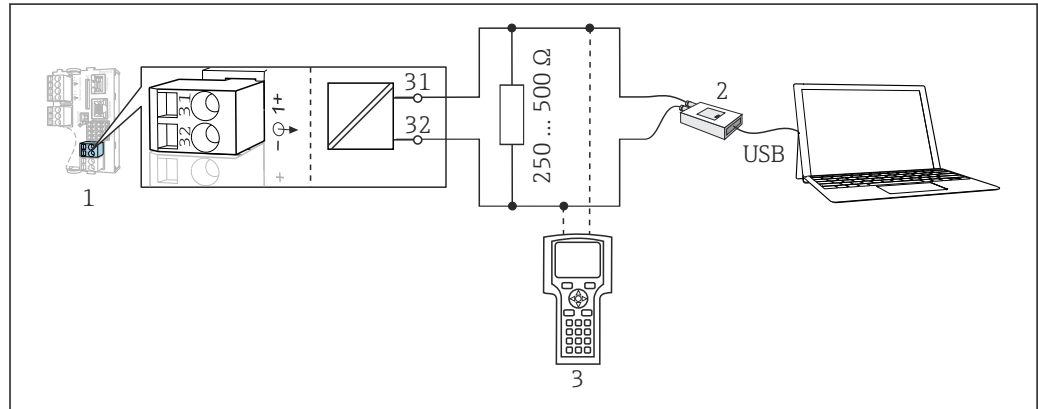
Remote operation**Via HART (e.g. via HART modem and FieldCare)**

A0039620

21 HART using modem

1 Device module Base2-E: current output 1 with HART

2 HART modem for connection to PC, e.g. Commubox FXA191 (RS232) or FXA195 ¹⁾ (USB)

3 HART handheld terminal

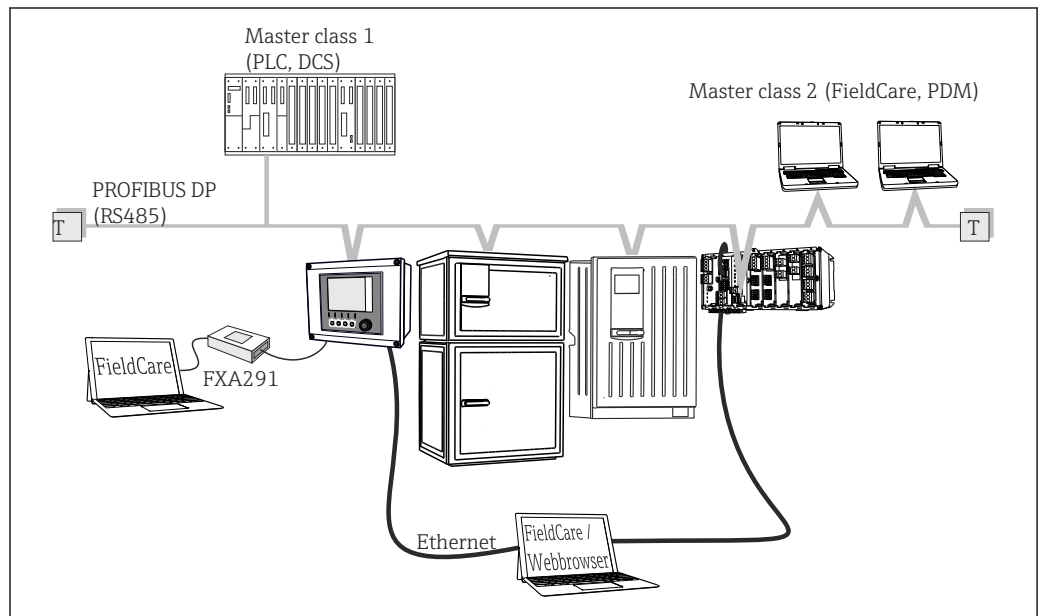
¹⁾ Switch position "on" (substitutes the resistor)**Via PROFIBUS DP**

A0039617

22 PROFIBUS DP

T Terminating resistor

Via Modbus RS485

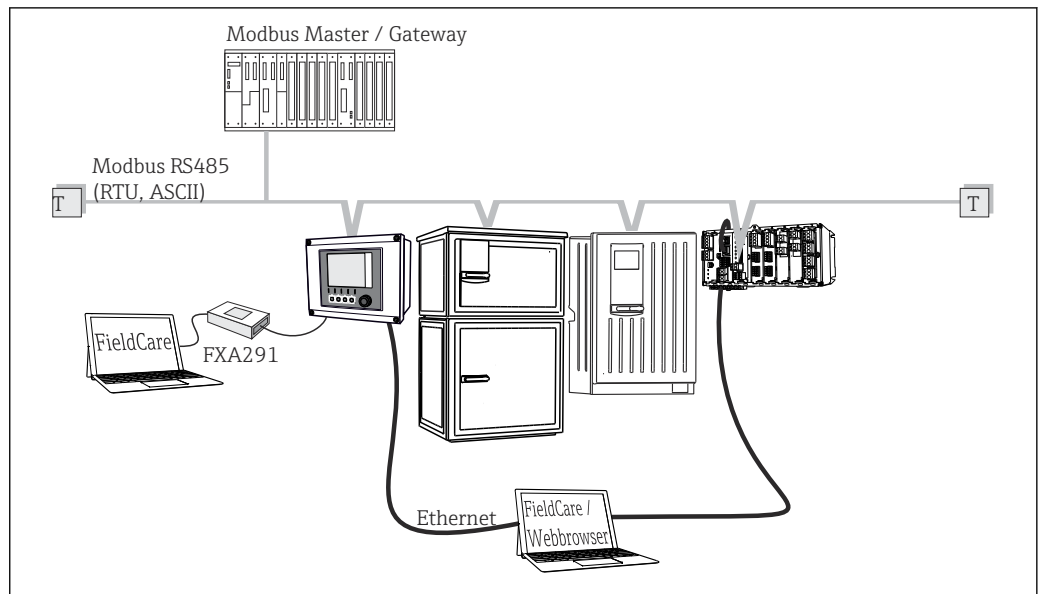

A0039615

23 Modbus RS485

T Terminating resistor

Via Ethernet: web server/Modbus TCP/PROFINET/Ethernet/IP

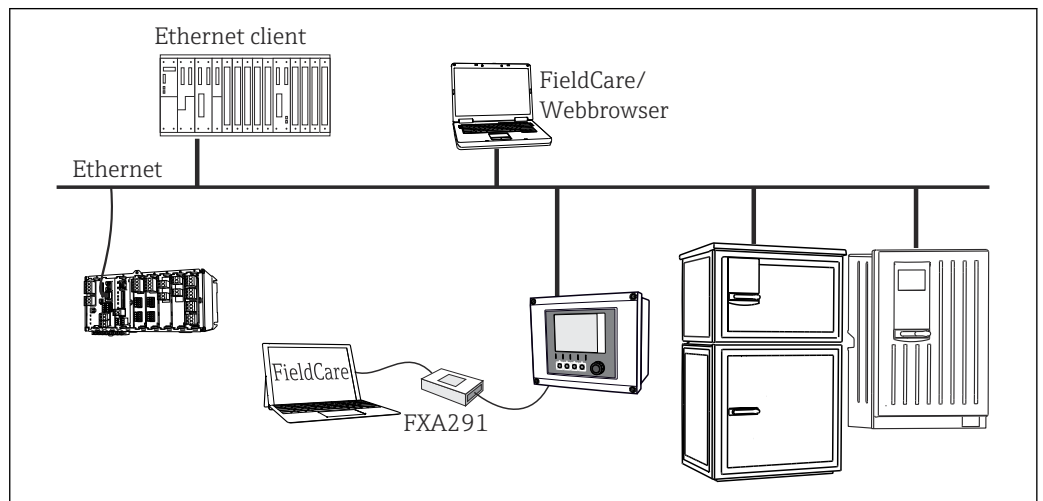

A0039616

24 Modbus TCP or EtherNet/IP or PROFINET

Language packages

The language selected in the product structure is the operating language preset at the factory. All other languages can be selected using the menu.

- English (US)
- German
- Chinese (Simplified, PR China)
- Czech
- Dutch
- French
- Italian
- Japanese
- Polish
- Portuguese
- Russian
- Spanish
- Turkish

- Hungarian
- Croatian
- Vietnamese

The availability of other languages can be checked via the product structure at www.endress.com/.

Certificates and approvals

Current certificates and approvals for the product are available at www.endress.com on the relevant product page:

1. Select the product using the filters and search field.
2. Open the product page.
3. Select **Downloads**.

Order information

Product page

www.endress.com/ca80si

Product Configurator

1. **Configure**: Click this button on the product page.
 2. Select **Extended selection**.
 - ↳ The Configurator opens in a separate window.
 3. Configure the device according to your requirements by selecting the desired option for each feature.
 - ↳ In this way, you receive a valid and complete order code for the device.
 4. **Accept**: Add the configured product to the shopping cart.
-  For many products, you also have the option of downloading CAD or 2D drawings of the selected product version.
5. **CAD**: Open this tab.
 - ↳ The drawing window is displayed. You have a choice between different views. You can download these in selectable formats.

Scope of delivery

Scope of delivery

- 1 analyzer in the version ordered with optional hardware
- 1 x Brief Operating Instructions (hard copy)
- **Accessories enclosed:**
 - Wall holder unit
 - Magnetic stir bar (for installation in cuvette)
 - 10 ml dispenser with hose (for draining cuvette and sample channel)
 - SD card (optional)
 - Supply hose
 - Sample outlet hose (for sample overflow)
 - Outlet hose (for overflow at cuvette)
 - 2 m Norprene hose ID 1.6 mm (for large reagent set)
 - Cable gland M32 PA (for large reagent set)
 - Counter nut M32 PA (for large reagent set)
 - O-ring ID 29.00 W 3.00 (for large reagent set)
 - Drain plug M32x1.5 with hole 4.9 (for large reagent set)

	1-channel	2-channel	4-channel	6-channel
Filters and pressure relief valves	1 filter, 1 pressure relief valve with angle bracket	2 filters, 2 pressure relief valves with angle brackets	Panel with 4 pre-installed filters and 4 pre-installed pressure relief valves	Panel with 6 pre-installed filters and 6 pre-installed pressure relief valves
Sample channel switching	in analyzer	in analyzer	pre-installed on panel	pre-installed on panel

Accessories

The following are the most important accessories available at the time this documentation was issued.

Listed accessories are technically compatible with the product in the instructions.

1. Application-specific restrictions of the product combination are possible.
Ensure conformity of the measuring point to the application. This is the responsibility of the operator of the measuring point.
2. Pay attention to the information in the instructions for all products, particularly the technical data.
3. For accessories not listed here, please contact your Service or Sales Center.

Device-specific accessories

Installation accessories

Kit CA8x wall holder unit for reagents

- Collecting tray wall mounting
- Kit installation instructions
- Order No. 71422095

Consumables

1. <https://portal.endress.com/webapp/SparePartFinder>
2. Specify the serial number or product code.

The following consumables are available:

Reagents and standard solutions CY80SI

Sensors

pH glass electrodes

Memosens CPS11E

- pH sensor for standard applications in process and environmental engineering
- Digital with Memosens 2.0 technology
- Product Configurator on the product page: www.endress.com/cps11e

 Technical Information TI01493C

Memosens CPS41E

- pH sensor for process technology
- With ceramic junction and KCl liquid electrolyte
- Digital with Memosens 2.0 technology
- Product Configurator on the product page: www.endress.com/cps41e

 Technical Information TI01495C

Memosens CPS71E

- pH sensor for chemical process applications
- With ion trap for poison-resistant reference
- Digital with Memosens 2.0 technology
- Product Configurator on the product page: www.endress.com/cps71e

 Technical Information TI01496C

Memosens CPS91E

- pH sensor for heavily polluted media
- With open aperture
- Digital with Memosens 2.0 technology
- Product Configurator on the product page: www.endress.com/cps91e



Technical Information TI01497C

Memosens CPS31E

- pH sensor for standard applications in drinking water and swimming pool water
- Digital with Memosens 2.0 technology
- Product Configurator on the product page: www.endress.com/cps31e



Technical Information TI01574C

Ceramax CPS341D

- pH electrode with pH-sensitive enamel
- Meets highest demands of measuring accuracy, pressure, temperature, sterility and durability
- Product Configurator on the product page: www.endress.com/cps341d



Technical Information TI00468C

Memosens CPF81E

- pH sensor for mining operations, industrial water and wastewater treatment
- Digital with Memosens 2.0 technology
- Product Configurator on the product page: www.endress.com/cpf81e



Technical Information TI01594C

*ORP electrodes***Memosens CPS12E**

- ORP sensor for standard applications in process and environmental engineering
- Digital with Memosens 2.0 technology
- Product Configurator on the product page: www.endress.com/cps12e



Technical Information TI01494C

Memosens CPS42E

- ORP sensor for process technology
- Digital with Memosens 2.0 technology
- Product Configurator on the product page: www.endress.com/cps42e



Technical Information TI01575C

Memosens CPS72E

- ORP sensor for chemical process applications
- Digital with Memosens 2.0 technology
- Product Configurator on the product page: www.endress.com/cps72e



Technical Information TI01576C

Memosens CPS92E

- ORP sensor for use in heavily polluted media
- Digital with Memosens 2.0 technology
- Product Configurator on the product page: www.endress.com/cps92e



Technical Information TI01577C

Memosens CPF82E

- ORP sensor for mining operations, industrial water and wastewater treatment
- Digital with Memosens 2.0 technology
- Product Configurator on the product page: www.endress.com/cpf82e



Technical Information TI01595C

Conductivity sensors with inductive measurement of conductivity

Indumax CLS50D

- High-durability inductive conductivity sensor
- For standard and hazardous area applications
- With Memosens technology
- Product Configurator on the product page: www.endress.com/cls50d



Technical Information TI00182C

Conductivity sensors with conductive measurement of conductivity

Memosens CLS21E

- Digital conductivity sensor for media with medium or high conductivity
- Conductive measurement
- With Memosens 2.0
- Product Configurator on the product page: www.endress.com/cls21e



Technical Information TI01528C

Oxygen sensors

Memosens COS51E

- Amperometric oxygen sensor for water, wastewater and utilities
- Digital with Memosens 2.0 technology
- Product Configurator on the product page: www.endress.com/cos51e



Technical Information TI01620C

Memosens COS81E

- Hygienic optical oxygen sensor with maximum measurement stability over multiple sterilization cycles
- Digital with Memosens 2.0 technology
- Product Configurator on the product page: www.endress.com/cos81e



Technical Information TI01558C

Memosens COS22E

- Hygienic amperometric oxygen sensor with maximum measurement stability over multiple sterilization cycles
- Digital with Memosens 2.0 technology
- Product Configurator on the product page: www.endress.com/cos22e



Technical Information TI01619C

Chlorine dioxide and chlorine sensors

Memosens CCS50E

- Membrane-covered amperometric sensor for chlorine dioxide
- With Memosens technology
- Product Configurator on the product page: www.endress.com/ccs50e



Technical Information TI01353C

Memosens CCS51E

- Sensor for measuring free available chlorine
- Product Configurator on the product page: www.endress.com/ccs51e



Technical Information TI01423C

Ion-selective sensors

ISEmax CAS40D

- Ion selective sensors
- Product Configurator on the product page: www.endress.com/cas40d



Technical Information TI00491C

*Turbidity sensors***Turbimax CUS51D**

- For nephelometric measurements of turbidity and solids in wastewater
- 4-beam scattered light method
- With Memosens technology
- Product Configurator on the product page: www.endress.com/cus51d



Technical Information TI00461C

Turbimax CUS52D

- Hygienic Memosens sensor for turbidity measurement in drinking water, process water and in utilities
- With Memosens technology
- Product Configurator on the product page: www.endress.com/cus52d



Technical Information TI01136C

*SAC and nitrate sensors***Viomax CAS51D**

- SAC and nitrate measurement in drinking water and wastewater
- With Memosens technology
- Product Configurator on the product page: www.endress.com/cas51d



Technical Information TI00459C

*Interface measurement***Turbimax CUS71D**

- Immersion sensor for interface measurement
- Ultrasonic interface sensor
- Product Configurator on the product page: www.endress.com/cus71d



Technical Information TI00490C

Cable junction with Velcro strip

- 4 pieces, for sensor cable
- Order No. 71092051

Communication-specific accessories**Additional functionality**

- ▶ Always quote the serial number of your device when ordering activation codes.

Order code	Communication; software
51516983	Commubox FXA291 (hardware)
71127100	SD card with Liquiline Firmware, 1 GB, Industrial Flash Drive
XPC0018	Activation code for EtherNet/IP + web server
XPC0020	Activation code for Modbus TCP + web server
XPC0021	Activation code for web server for BASE2
XPC0022	Activation code for PROFINET + web server for BASE2
XPC0024	Activation code for Profibus DP for module 485
XPC0025	Activation code for Modbus RS485 for module 485
71249548	Kit CA80: activation code for 1st digital sensor input
71249555	Kit CA80: activation code for 2nd digital sensor input

	Retrofit kits
71136999	Kit CSF48/CA80: retrofit service interface (CDI flange connector, counter nut)
71111053	Kit module AOR: 2 x relay, 2 x analog output 0/4 to 20 mA

	Retrofit kits
71125375	Kit module 2R: 2 x relay
71125376	Kit module 4R: 4 x relay
71135632	Kit module 2AO: 2 x analog output 0/4 to 20 mA
71135633	Kit module 4AO: 4 x analog output 0/4 to 20 mA
71135631	Kit module 2DS: 2 x digital sensor, Memosens
71135634	Kit module 485: PROFIBUS DP or Modbus RS485. This requires an additional activation code which can be ordered separately.
71135638	Kit module DIO: 2 x digital input; 2 x digital output; auxiliary power supply for digital output
71135639	Kit module 2AI: 2 x analog input 0/4 to 20 mA
71140888	Upgrade kit module 485 + Profibus DP
71140889	Upgrade kit module 485 + Modbus RS485
71141366	Kit, extension backplane module

Software

Memobase Plus CYZ71D

- PC software to support laboratory calibration
- Visualization and documentation of sensor management
- Sensor calibrations stored in database
- Product Configurator on the product page: www.endress.com/cyz71d



Technical Information TI00502C

Field Data Manager Software MS20/21

- PC software for central data management
- Visualization of series of measurements and logbook events
- SQL database for secure data storage

System components

Measuring cables

Memosens data cable CYK10

- For digital sensors with Memosens technology
- Product Configurator on the product page: www.endress.com/cyk10



Technical Information TI00118C

Memosens data cable CYK11

- Extension cable for digital sensors with Memosens protocol
- Product Configurator on the product page: www.endress.com/cyk11



Technical Information TI00118C

SD card

- Industrial Flash Drive, 1 GB
- Order number: 71110815





www.addresses.endress.com
