



Brief Operating Instructions Soliphant T FTM21

Level switch for bulk solids
Vibronic



These Brief Operating Instructions are not a substitute for the Operating Instructions (KA00227F) pertaining to the device.
Detailed information can be found in the Operating Instructions KA00227F and the additional documentation.

Available for all device versions via:

- Internet: www.endress.com/deviceviewer
- Smartphone/tablet: Endress+Hauser Operations app

Basic safety instructions

Manufacturer's address

Manufacturer: Endress+Hauser SE+Co. KG, Hauptstraße 1, D-79689 Maulburg
or www.endress.com.

Place of manufacture: See nameplate.

Requirements for the personnel

The operating personnel must fulfill the following requirements:

- ▶ Trained, qualified specialists: must have a relevant qualification for this specific function and task
- ▶ Are authorized by the plant operator
- ▶ Are familiar with national regulations
- ▶ They must have read and understood the instructions in the manual, supplementary documentation and certificates (depending on the application) prior to starting work
- ▶ They must follow instructions and comply with basic conditions

Intended use

- The device may only be used as a level switch for silos with fine-grained or coarse-grained, non-fluidized bulk solids. It is used to detect minimum or maximum levels.

Mounting

NOTICE

- ▶ Do not bend, shorten or extend the rod probe
- ▶ Take buildup into account

Mounting requirements

 Comply with the following according to IEC/EN61010-1: provide a suitable circuit breaker for the device.

Ambient temperature:

-40 to +70 °C (-40 to +158 °F)

Process temperature:

-40 to +150 °C (-40 to +302 °F)

Process pressure:

max. 25 bar (362.5 psi)

Bulk weight:

min. 200 g/l

Particle size:

max. 25 mm (0.98 in)

- Use only tools that have been insulated against ground
- Only use original parts

Workplace safety

When working on and with the device:

- ▶ Wear the required personal protective equipment as per national regulations.

Operational safety

- ▶ Operate the device only if it is in proper technical condition, free from errors and faults.
- ▶ The operator is responsible for ensuring that the device is in good working order.
- ▶ Only use the device for the intended purpose in the hazardous area (see nameplate).

Product safety

This product is designed in accordance with good engineering practice to meet state-of-the-art safety requirements and has been tested and left the factory in a condition in which it is safe to operate.

Sensor lengths:

500 mm (20 in), 1 000 mm (40 in), 1 500 mm (60 in)

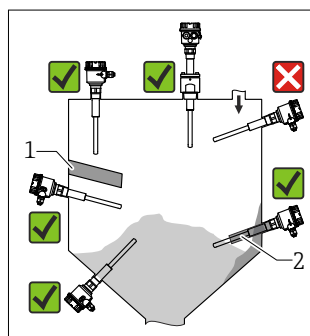

1 Installation in any direction in the bulk solids silo

- 1 Protective roof
- 2 Protection pipe

Mounting the device

Required tools

Open-ended wrench, see caption

- Tighten by the hexagonal nut only.
- Torque: 5 to 12 Nm (3.7 to 8.9 lbf ft)

Screwing in the device

Do not turn at the housing!

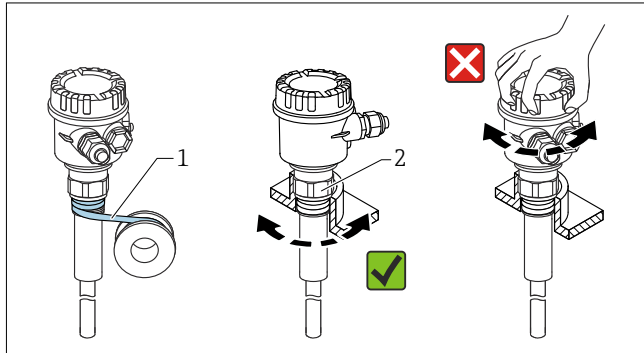

- 1 Wrap the thread with PTFE tape.
- 2 NPT 1¼ (AF 1¾ "); R 1 (AF 4 1); NPT 1½ (AF 2 "); R 1½ (AF 50); G 1½ (AF 55)

Aligning the housing

- ▶ Align the housing in such a way that no rainwater can enter the housing via the cable entry.

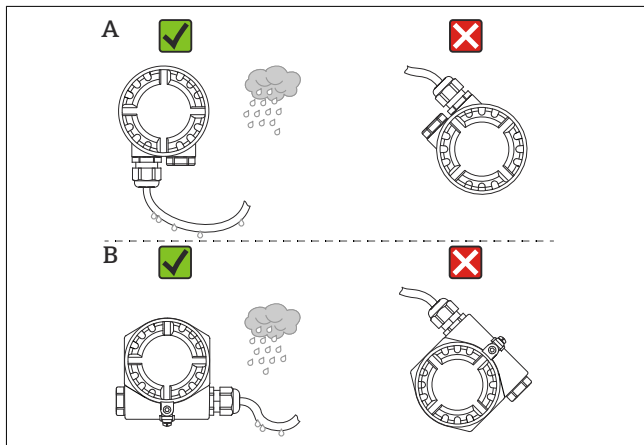

- A F16 housing (polyester)
B F18 housing (aluminium)

Electrical connection

- i** Depending on the application, the device is fitted with one of the various electronic inserts, see Technical Information.

Connecting the device

Required tools

- Flat-blade screwdriver (0.6 mm (0.02 in) x 3.5 mm (0.14 in)) for terminals
- Suitable tool with width across flats AF24/25 (8 Nm (5.9 lbf ft)) for M20 cable gland

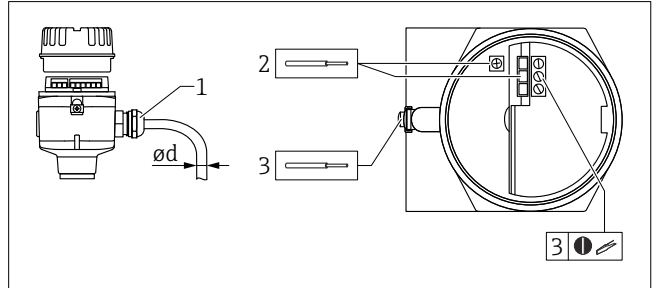

- 2** Example of coupling with cable entry, electronic insert with terminals

- 1 M20 coupling (with cable entry), example
 $\varnothing d$ Nickel-plated brass 7 to 10,5 mm (0,28 to 0,41 in)
 $\varnothing d$ Plastic 5 to 10 mm (0,2 to 0,38 in)
 $\varnothing d$ Stainless steel 7 to 12 mm (0,28 to 0,47 in)
- 2 Conductor cross-section maximum 2,5 mm² (AWG14), ground terminal inside the housing + terminals on the electronics
- 3 Conductor cross-section maximum 4,0 mm² (AWG12), ground terminal on outside of the housing (example: plastic housing with outer protective ground connection (PE))

1. Connect the device according to the connection diagram of the electronic insert used, see Technical Information.
2. Configure the device for the intended purpose via the electronic insert used, see Technical Information.

Ensuring the degree of protection

Testing as per IEC 60529
IP66/IP67, NEMA 4X