

Operating Instructions

Deltapilot S FMB70

Hydrostatic level measurement
FOUNDATION Fieldbus

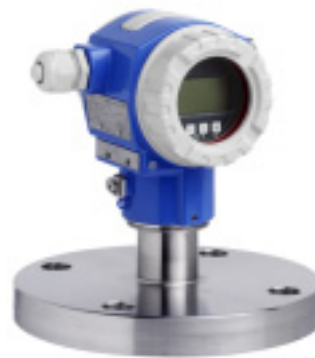

Make sure the document is stored in a safe place such that it is always available when working on or with the device.

To avoid danger to individuals or the facility, read the "Basic safety instructions" section carefully, as well as all other safety instructions in the document that are specific to working procedures.

The manufacturer reserves the right to modify technical data without prior notice. Your Endress+Hauser distributor will supply you with current information and updates to this manual.

Table of contents

1	About this document	4	7.8	Scaling OUT parameter	58
1.1	Document function	4	7.9	Configuring diagnostic behavior in accordance with FOUNDATION Fieldbus Specification FF912 Field Diagnostic Profile	59
1.2	Symbols	4	8	Maintenance	69
1.3	Registered trademarks	5	8.1	Exterior cleaning	69
2	Basic safety instructions	6	9	Diagnostics and troubleshooting	70
2.1	Requirements for the personnel	6	9.1	Troubleshooting	70
2.2	Intended use	6	9.2	Diagnostic information on onsite display	71
2.3	Workplace safety	6	9.3	Diagnostic event in the operating tool	72
2.4	Operational safety	6	9.4	Diagnostic messages in the DIAGNOSTIC Transducer Block (TRDDIAG)	73
2.5	Hazardous area	7	9.5	Overview of diagnostic events	76
2.6	Product safety	7	9.6	Response of outputs to errors	85
3	Identification	8	9.7	Confirming messages	86
3.1	Product identification	8	9.8	Repair	87
3.2	Device designation	8	9.9	Repair of Ex-certified devices	87
3.3	Scope of delivery	8	9.10	Spare parts	87
3.4	CE mark, Declaration of Conformity	9	9.11	Returns	87
4	Mounting	10	9.12	Disposal	87
4.1	Incoming acceptance, storage	10	9.13	Software history	88
4.2	Installation conditions	10	10	Technical data	89
4.3	General installation instructions	10	11	Appendix	89
4.4	Installation	10	11.1	Assignment of English parameter names on the onsite display	89
4.5	Post-installation check	16	Index	93	
5	Wiring	17			
5.1	Connecting the device	17			
5.2	Connecting the measuring unit	18			
5.3	Overvoltage protection (optional)	19			
5.4	Post-connection check	19			
6	Operation	20			
6.1	Onsite display (optional)	20			
6.2	Operating elements	22			
6.3	FOUNDATION Fieldbus interface	25			
6.4	Onsite operation – onsite display connected	37			
6.5	FieldCare	40			
6.6	HistoROM®/M-DAT (optional)	40			
6.7	Locking/unlocking operation	43			
6.8	Simulation	44			
6.9	Factory setting (reset)	44			
7	Commissioning	47			
7.1	Configuring messages	47			
7.2	Function check	47			
7.3	Commissioning via an FF configuration program	47			
7.4	Selecting the language and measuring mode	49			
7.5	Position adjustment	51			
7.6	Level measurement	52			
7.7	Pressure measurement	56			





1 About this document

1.1 Document function







These Operating Instructions contain all the information that is required in the various phases of the life cycle of the device: from product identification, incoming acceptance and storage, to mounting, connection, operation and commissioning through to troubleshooting, maintenance and disposal.

1.2 Symbols



1.2.1 Safety symbols

Symbol	Meaning
 A0011189-EN	DANGER! This symbol alerts you to a dangerous situation. Failure to avoid this situation will result in serious or fatal injury.
 A0011190-EN	WARNING! This symbol alerts you to a dangerous situation. Failure to avoid this situation can result in serious or fatal injury.
 A0011191-EN	CAUTION! This symbol alerts you to a dangerous situation. Failure to avoid this situation can result in minor or medium injury.
 A0011192-EN	NOTE! This symbol contains information on procedures and other circumstances that do not result in personal injury.









1.2.2 Electrical symbols

Symbol	Meaning	Symbol	Meaning
	Direct current		Alternating current
	Direct current and alternating current		Ground connection A grounded terminal which, as far as the operator is concerned, is grounded via a grounding system.
	Protective ground connection A terminal that must be connected to the ground prior to establishing any other connections.		Equipotential connection A connection that has to be connected to the plant grounding system: This may be a potential equalization line or a star grounding system depending on national or company codes of practice.

1.2.3 Tool symbols

Symbol	Meaning
 A0011221	Allen key
 A0011222	Open-ended wrench

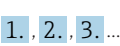
1.2.4 Symbols for certain types of Information

Symbol	Meaning
 A0011182	Permitted Indicates procedures, processes or actions that are allowed.
 A0011184	Not permitted Indicates procedures, processes or actions that are forbidden.
 A0011193	Tip Indicates additional information.
 A0028658	Reference to documentation
 A0028659	Reference to page.
 A0028660	Reference to graphic
 A0031595	Series of steps
 A0018343	Result of a series of actions
 A0028673	Visual inspection

1.2.5 Symbols in graphics

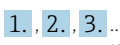
Symbol	Meaning
1, 2, 3, 4 etc.	Numbering of main items
 A0031595	Series of steps
A, B, C, D etc.	Views

1.2.6 Symbols on the device

Symbol	Meaning
 A0019159	Safety notice Observe the safety instructions contained in the associated operating instructions.

1.3 Registered trademarks

KALREZ®

Registered label of E.I. Du Pont de Nemours & Co., Wilmington, USA

TRI-CLAMP®

Registered label of Ladish & Co., Inc., Kenosha, USA

FOUNDATION™ Fieldbus

Registered trademark of the FieldComm Group, Austin, USA

GORE-TEX®

Trademark of W.L. Gore & Associates, Inc., USA

2 Basic safety instructions

2.1 Requirements for the personnel

The personnel responsible for installation, commissioning, diagnostics and maintenance must fulfil the following requirements:

- Trained, qualified specialists must have a relevant qualification for this specific function and task
- They must be authorized by the plant operator
- They must be familiar with national regulations
- Before beginning work, the specialist staff must have read and understood the instructions in the Operating Instructions and supplementary documentation as well as in the certificates (depending on the application)
- They must follow instructions and comply with basic conditions

The operating personnel must fulfil the following requirements:

- They must be instructed and authorized according to the requirements of the task by the plant operator
- They must follow these Operating Instructions

2.2 Intended use

The Deltapilot S is a hydrostatic pressure sensor for measuring level and pressure.

2.2.1 Incorrect use

The manufacturer is not liable for damage caused by improper or unintended use.

Clarification for borderline cases:

In the case of special fluids and fluids used for cleaning, Endress+Hauser is glad to provide assistance in clarifying the corrosion resistance of wetted materials, but does not accept any warranty or liability.

2.3 Workplace safety

When working on and with the device:

- Wear the required personal protective equipment as per national regulations.
- Switch off the supply voltage before connecting the device.

2.4 Operational safety

Risk of injury!

- ▶ Operate the device only if it is in proper technical condition, free from errors and faults.
- ▶ The operator is responsible for ensuring that the device is in good working order.

Modifications to the device

Unauthorized modifications to the device are not permitted and can lead to unforeseeable dangers:

- ▶ If, despite this, modifications are required, consult with Endress+Hauser.

Repair

To ensure continued operational safety and reliability:

- ▶ Carry out repairs on the device only if they are expressly permitted.
- ▶ Observe federal/national regulations pertaining to the repair of an electrical device.
- ▶ Use original spare parts and accessories from Endress+Hauser only.

2.5 Hazardous area

To eliminate danger to persons or the installation when the device is used in the hazardous area (e.g. explosion protection, pressure vessel safety):

- Check the nameplate to verify if the device ordered can be put to its intended use in the hazardous area.
- Comply with the instructions in the separate supplementary documentation, which is an integral part of this manual.

2.6 Product safety

This measuring instrument is designed in accordance with good engineering practice to meet state-of-the-art safety requirements, has been tested, and left the factory in a condition in which it is safe to operate. It meets general safety standards and legal requirements. It also conforms to the EC directives listed in the device-specific EC Declaration of Conformity. Endress+Hauser confirms this by affixing the CE mark to the device.

3 Identification

3.1 Product identification

The measuring instrument can be identified in the following ways:

- Nameplate specifications
- Order code with breakdown of the device features on the delivery note
- Enter the serial number from the nameplates in W@M Device Viewer (www.endress.com/deviceviewer): All the information about the measuring instrument is displayed.

For an overview of the technical documentation provided, enter the serial number from the nameplates in W@M Device Viewer (www.endress.com/deviceviewer).

3.1.1 Manufacturer address

Endress+Hauser SE+Co. KG
Hauptstraße 1
79689 Maulburg, Germany
Address of the manufacturing plant: See nameplate.

3.2 Device designation

3.2.1 Nameplate

Different nameplates are used depending on the device version.

The nameplates contain the following information:

- Manufacturer name and device name
- Address of the certificate holder and country of manufacture
- Order code and serial number
- Technical data
- Approval-specific information

Compare the data on the nameplate with your order.

3.2.2 Identification of sensor type

See parameter "Sensor Meas.Type" in Operating Instruction BA00303P.

3.3 Scope of delivery

The scope of delivery comprises:

- Deltapilot S hydrostatic pressure sensor
- For devices with the "HistoROM/M-DAT" option:
CD-ROM with Endress+Hauser operating program
- Optional accessories

Documentation supplied:

- The BA00372P and BA00303P Operating Instructions are available on the Internet.
→ See: www.endress.com → Downloads.
- Brief Operating Instructions KA01026P
- Fold-out brochure KA00252P
- Final inspection report
- Additional safety instructions for Ex devices
- Optional: factory calibration certificate, test certificates

3.4 CE mark, Declaration of Conformity

The devices are designed to meet state-of-the-art safety requirements, have been tested and left the factory in a condition in which they are safe to operate. The devices comply with the applicable standards and regulations as listed in the EC Declaration of Conformity and thus comply with the statutory requirements of the EC Directives. Endress+Hauser confirms the successful testing of the device by affixing to it the CE mark.

4 Mounting

4.1 Incoming acceptance, storage

4.1.1 Incoming acceptance

- Check the packaging and contents for any signs of damage.
- Check the shipment, make sure nothing is missing and that the scope of supply matches your order.

4.1.2 Transportation to measuring point

▲ WARNING

Incorrect transportation

Housing and membrane may become damaged, and there is a risk of injury.

- ▶ Transport the measuring instrument to the measuring point in its original packaging or by the process connection (with secure transport protection for the membrane).
- ▶ Follow the safety instructions and transport conditions for devices weighing more than 18 kg (39.6 lbs).

4.1.3 Storage

The measuring instrument must be stored in a dry, clean area and protected against impact (EN 837-2).

Storage temperature range:

See Technical Information.

4.2 Installation conditions

4.2.1 Dimensions

→ For dimensions, please refer to the Technical Information for Deltapilot S TI00416P, "Mechanical construction" section.

4.3 General installation instructions

- Devices with a G 1 1/2 thread:
When screwing the device into the tank, the flat seal has to be positioned on the sealing surface of the process connection. To avoid additional strain on the process membrane, the thread should never be sealed with hemp or similar materials.
- Devices with NPT threads:
 - Wrap Teflon tape around the thread to seal it.
 - Tighten the device at the hexagonal bolt only. Do not turn at the housing.
 - Do not overtighten the thread when screwing in the screw. Max. torque: 20 to 30 Nm (14.75 to 22.13 lbf ft)

4.4 Installation

- Due to the orientation of the Deltapilot S, a zero point shift may occur, i.e. when the vessel is empty or partially full, the measured value does not display zero. You can correct this zero point shift either via the "zero" key on the electronic insert, or on the outside of the device or via the onsite display. See → [§ 22](#), section 6.2.1 "Position of operating elements", → [§ 23](#), section 6.2.2 "Function of operating elements – onsite display not connected" and → [§ 51](#), section 7.5 "Position adjustment".

- To ensure optimum readability of the onsite display, it is possible to rotate the housing by up to 380°. See → 15, section 4.4.5 "Rotating the housing".
- Endress+Hauser offers a mounting bracket for installations on pipes or walls. See → 13, section 4.4.3 "Wall and pipe mounting (optional)".

4.4.1 Installation instructions

NOTICE

Damage to the device!

If a heated Deltapilot S is cooled during the cleaning process (e.g. by cold water), a vacuum develops for a short time, and as a result, moisture can enter the sensor through the pressure compensation (1).

- ▶ Mount the device as follows.

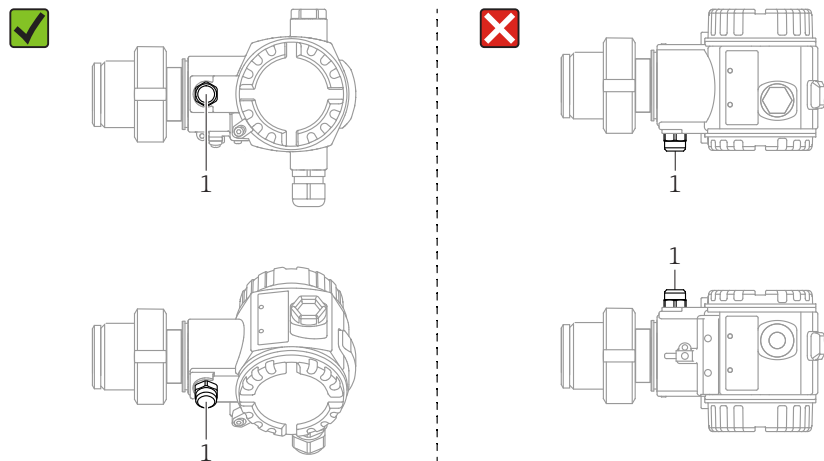

- Keep the pressure compensation and GORE-TEX® filter (1) free from contamination.
- Do not clean or touch process membranes with hard or pointed objects.
- The device must be installed as follows in order to comply with the cleanability requirements of the ASME-BPE (Part SD Cleanability):

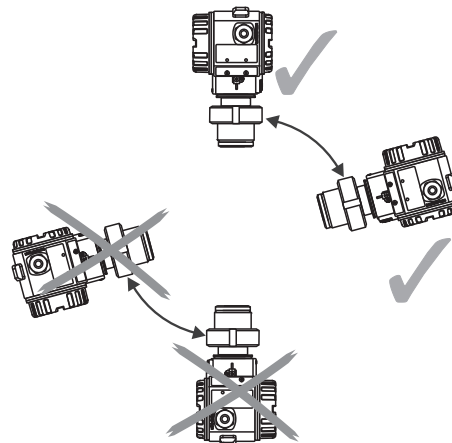

Level measurement

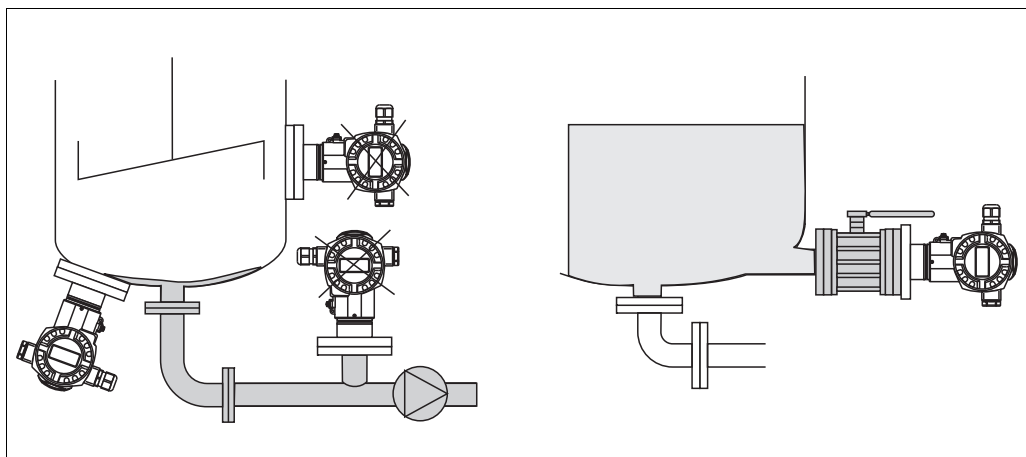

Fig. 1: Measuring arrangement for level

P01-PMP75xxx-11-xx-xx-xx-000

- Always install the device below the lowest measuring point.
- Do not install the device at the following positions:
 - in the filling curtain
 - in the tank outlet
 - in the suction area of a pump
 - or at a point in the tank which could be affected by pressure pulses from the agitator.
- The adjustment and functional test can be carried out more easily if you mount the device downstream from a shutoff device.
- The Deltapilot S must also be insulated in the case of media that can harden when cold.

Pressure measurement in gases

- Mount the Deltapilot S with shutoff device above the tapping point so that any condensate can flow into the process.

Pressure measurement in steams

- Mount the Deltapilot S with the siphon above the tapping point.
- Fill the siphon with liquid before commissioning.
The siphon reduces the temperature to almost ambient temperature.

Pressure measurement in liquids

- Mount the Deltapilot S with the shutoff device below or at the same level as the tapping point.

4.4.2 Seal for flange mounting

NOTICE

Incorrect measurement results

The seal is not allowed to press against the process membrane as this could affect the measurement result.

- ▶ Ensure that the seal is not touching the process membrane.

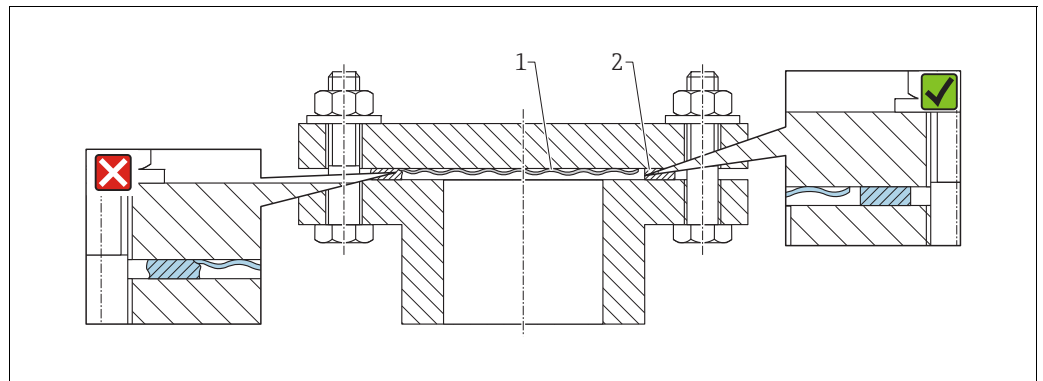
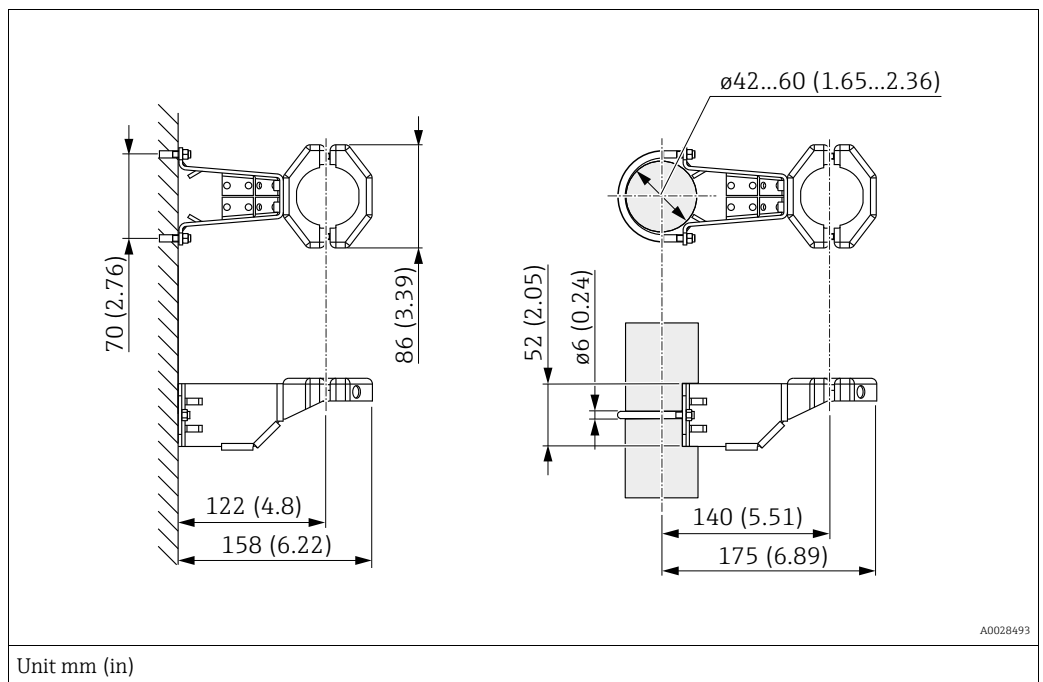

Fig. 2:
 1 Process membrane
 2 Seal

4.4.3 Wall and pipe mounting (optional)

Endress+Hauser offers a mounting bracket for installation on pipes or walls (for pipe diameters from 1 1/4" to 2").



Please note the following when mounting:

- Devices with capillaries: mount capillaries with a bending radius ≥ 100 mm (3.94 in).
- When mounting on a pipe, tighten the nuts on the bracket uniformly with a torque of at least 5 Nm (3.69 lbs ft).

4.4.4 Assembling and mounting the "separate housing" version

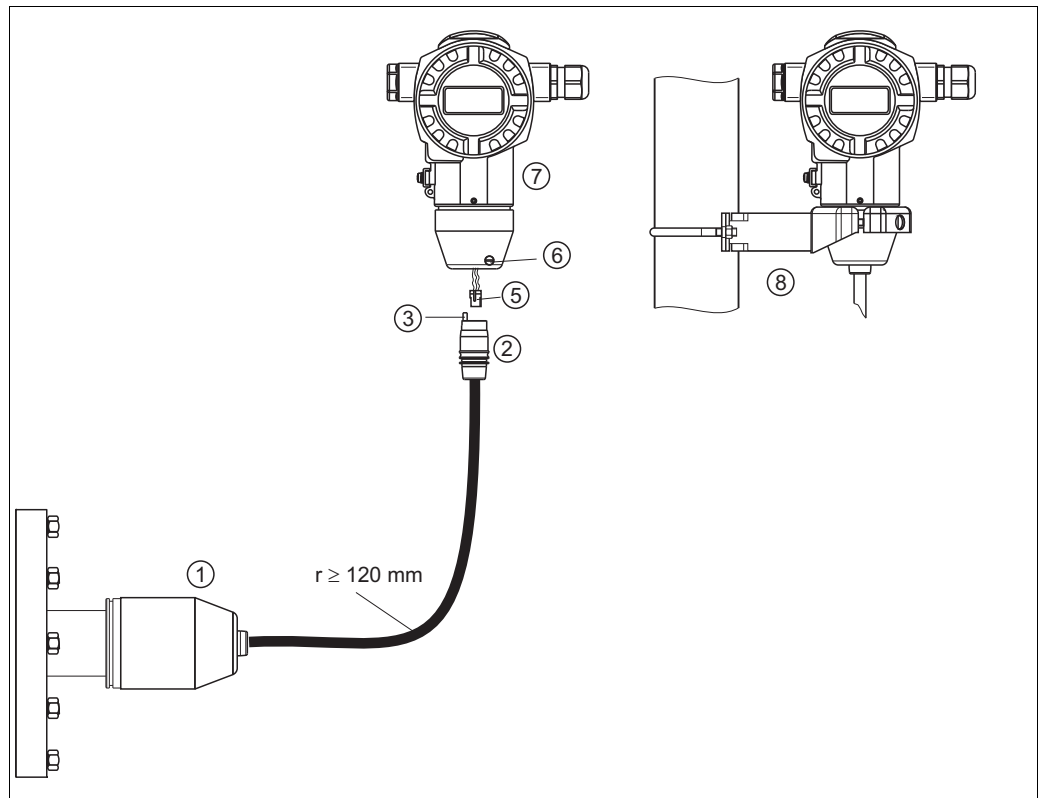

P01-FMB70xxx-11-xx-xx-xx-003

Fig. 3: "Separate housing" version

- 1 In the "separate housing" version, the sensor is supplied with process connection and cable fitted.
- 2 Cable with connection jack
- 3 Pressure compensation
- 5 Plug
- 6 Locking screw
- 7 Housing fitted with housing adapter, included
- 8 Mounting bracket suitable for wall and pipe mounting, included

Assembly and mounting

1. Connect plug (item 5) into the corresponding connection jack of the cable (item 2).
2. Plug the cable into the housing adapter (item 7).
3. Tighten the locking screw (item 6).
4. Mount the housing on a wall or pipe using the mounting bracket (item 8).
When mounting on a pipe, tighten the nuts on the bracket uniformly with a torque of at least 5 Nm (3.69 lbs ft).
Mount the cable with a bending radius (r) ≥ 120 mm (4.72 in).

4.4.5 Rotating the housing

The housing can be rotated by up to 380° by loosening the setscrew.

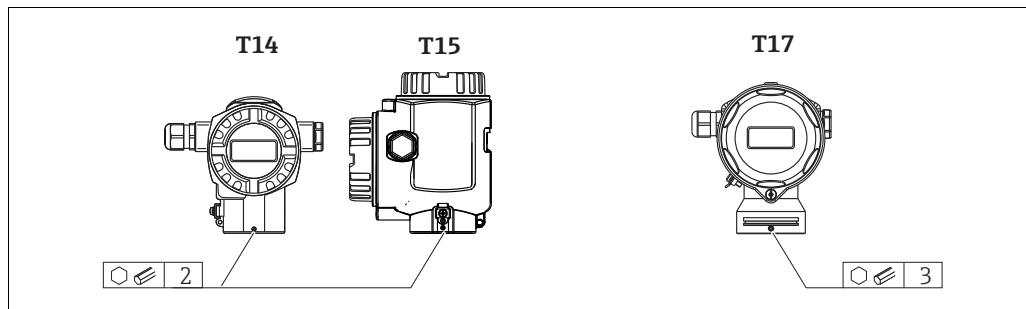

A0019996

1. T14 housing: loosen the setscrew with a 2 mm (0.08 in) Allen key.
T15 and T17 housing: loosen the setscrew with a 3 mm (0.12 in) Allen key.
2. Rotate the housing (max. up to 380°).
3. Retighten the setscrew with 1 Nm (0.74 lbf ft).

4.4.6 Closing the housing covers

NOTICE

Devices with EPDM cover seal - leaking transmitter!

Mineral-, animal- or plant-based lubricants cause the EPDM cover seal to swell and the transmitter to leak as a result.

- ▶ It is not necessary to grease the thread due to the coating applied to the thread at the factory.

NOTICE

The housing cover can no longer be closed.

Damaged thread!

- ▶ When closing the housing cover, please ensure that the thread of the cover and housing are free from dirt, e.g. sand. If you encounter resistance when closing the covers, then check the threads again for dirt or fouling.

Closing the cover on a hygienic stainless steel housing (T17)

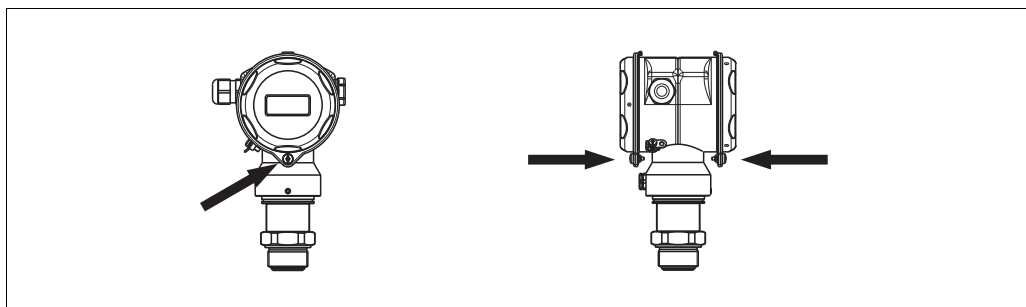

P01-FMB70xxx-17-xx-xx-xx-001

Fig. 4: Closing the cover

The covers for the terminal compartment and electronics compartment are hooked into the housing and closed with a screw in each case. These screws should be finger-tightened (2 Nm (1.48 lbf ft)) to the stop to ensure that the covers sit tightly.

4.4.7 Mounting the profile seal for the universal process adapter

For details on mounting, see KA00096F/00/A3.

4.5 Post-installation check

After installing the device, carry out the following checks:

- Are all screws firmly tightened?
- Are the housing covers screwed down tight?

5 Wiring

5.1 Connecting the device

⚠ WARNING

Risk of electric shock!

If the operating voltage is > 35 VDC: Dangerous contact voltage at terminals.

- ▶ In a wet environment, do not open the cover if voltage is present.

⚠ WARNING

Electrical safety is compromised by an incorrect connection!

- Risk of electric shock and/or explosion! Switch off the supply voltage before connecting the device.
- When using the measuring instrument in hazardous areas, installation must also comply with the applicable national standards and regulations and the Safety Instructions or Installation or Control Drawings.
- Devices with integrated overvoltage protection must be grounded.
- Protective circuits against reverse polarity, HF influences, and overvoltage peaks are integrated.
- The supply voltage must match the supply voltage on the nameplate.
- Switch off the supply voltage before connecting the device.
- Remove housing cover of the terminal compartment.
- Guide cable through the gland. → For cable specification, see → 18, section 5.2.4. Tighten the cable glands or cable entries so that they are leak-tight. Counter-tighten the housing entry. Use a suitable tool with width across flats AF24/25 (8 Nm (5.9 lbf ft) for the M20 cable gland.
- Connect the device as indicated in the following diagram.
- Screw down the housing cover.
- Switch on the supply voltage.

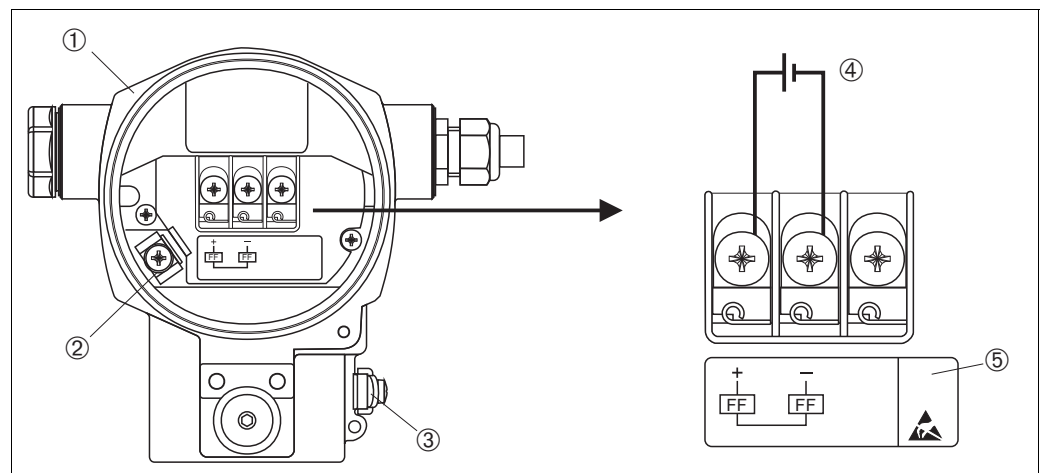
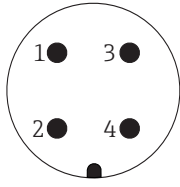

Fig. 5: Electrical connection of FOUNDATION Fieldbus
→ Please refer also to section 5.2.1 "Supply voltage", → 18.

- 1 Housing
- 2 Internal ground terminal
- 3 External ground terminal
- 4 Supply voltage, for version in non-hazardous area = 9 to 32 V DC
- 5 Devices with integrated overvoltage protection are labeled OVP (overvoltage protection) here.

5.1.1 Devices with 7/8" plug

PIN assignment for 7/8" plug	PIN	Meaning
	1	Signal -
	2	Signal +
	3	Not assigned
	4	Shielding

5.2 Connecting the measuring unit

For further information on the network structure and grounding and for further bus system components such as bus cables, see the relevant documentation, e.g. Operating Instructions BA00013S "FOUNDATION Fieldbus Overview" and the FOUNDATION Fieldbus Guideline.

5.2.1 Supply voltage

⚠ WARNING

Supply voltage might be connected!

Risk of electric shock and/or explosion!

- ▶ When using the measuring instrument in hazardous areas, installation must also comply with the applicable national standards and regulations and the Safety Instructions or Installation or Control Drawings.
- ▶ All explosion protection data are provided in separate Ex documentation, which is available on request. The Ex documentation is supplied as standard with all devices approved for use in hazardous areas.

Version for non-hazardous areas: 9 to 32 V DC

5.2.2 Current consumption

15.5 mA \pm 1 mA, switch-on current corresponds to IEC 61158-2, Clause 21.

5.2.3 Terminals

- Supply voltage and internal ground terminal: 0.5 to 2.5 mm² (20 to 14 AWG)
- External ground terminal: 0.5 to 4 mm² (20 to 12 AWG)

5.2.4 Cable specification

- Use a twisted, shielded twin-core cable, preferably cable type A.
- Outer cable diameter: 5 to 9 mm (0.2 to 0.35 in)

For further information on the cable specifications, see Operating Instructions BA00013S "FOUNDATION Fieldbus Overview", FOUNDATION Fieldbus Guideline and IEC 61158-2 (MBP).

5.2.5 Grounding and shielding

The Deltapilot S must be grounded, for example by means of the external ground terminal.

Different grounding and shielding installation methods are available for FOUNDATION Fieldbus networks such as:

- Isolated installation (see also IEC 61158-2)
- Installation with multiple grounding
- Capacitive installation.

5.3 Overvoltage protection (optional)

NOTICE

Device could be destroyed!

Devices with integrated overvoltage protection must be grounded.

Devices showing version "M" in feature 100 "Additional options 1" or feature 110 "Additional options 2" in the order code are equipped with overvoltage protection (→ see also Technical Information TI00416P "Ordering information").

- Overvoltage protection:
 - Nominal functioning DC voltage: 600 V
 - Nominal discharge current: 10 kA
- Surge current check $\hat{i} = 20 \text{ kA}$ satisfied as per DIN EN 60079-14: 8/20 μs
- Arrester AC current check $I = 10 \text{ A}$ satisfied

5.4 Post-connection check

Perform the following checks after completing the electrical installation of the device:

- Does the supply voltage match the specification on the nameplate?
- Is the device connected as per section 5.1?
- Are all screws firmly tightened?
- Are the housing covers screwed down tight?

As soon as voltage is applied to the device, the green LED on the electronic insert lights up for a few seconds or the connected onsite display lights up.

6 Operation

Feature 20 "Output; operation" in the order code provides you with information on the operating options available to you.

Version in the order code		Operation
P	FOUNDATION Fieldbus; external operation, LCD	Via onsite display and 1 key on the exterior of the device
Q	FOUNDATION Fieldbus; internal operation, LCD	Via onsite display and 1 key on the inside of the device
R	FOUNDATION Fieldbus; internal operation	Without onsite display, 1 key on the inside of the device

6.1 Onsite display (optional)

A 4-line liquid crystal display (LCD) is used for display and operation. The onsite display shows measured values, fault messages and notice messages.

The display of the device can be turned in 90° steps.

Depending on the orientation of the device, this makes it easy to operate the device and read the measured values.

Functions:

- 8-digit measured value display including sign and decimal point, unit display
- Bar graph as graphic display of the current pressure measured value in relation to the set pressure range in the Pressure Transducer Block. The pressure range is set by means of the SCALE_IN parameter
- Simple and complete menu guidance due to breakdown of parameters into several levels and groups
- Menu guidance

The onsite display is available in English. The assignment of the English parameter names to the German parameter names is provided in → section 11.1 "Assignment of English parameter names on the onsite display". Needless to say, the device can also be operated in 6 languages (de, en, fr, es, jp, ch) via the DTM or EDD. The FieldCare program is an E+H DTM operating tool and can be acquired from endress.com.
- Each parameter is assigned a 3-digit ID number for easy navigation
- Option for configuring the display according to individual requirements and desires, such as language, alternating display, contrast setting, display of other measured values such as sensor temperature
- Comprehensive diagnostic functions (fault and warning message, maximum/minimum indicators, etc.)
- Rapid and safe commissioning using Quick Setup menus

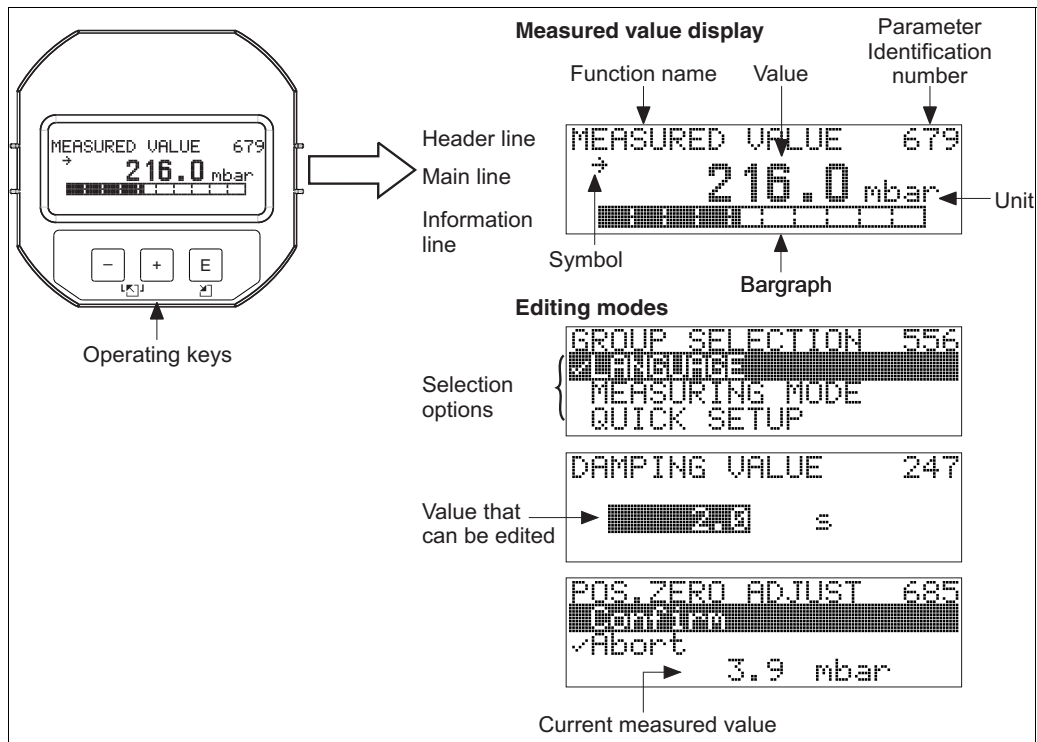

The following table illustrates the symbols that can appear on the onsite display. Four symbols may appear at the same time.

Symbol	Meaning
	Alarm symbol - Symbol flashing: warning, device continues measuring. - Symbol permanently lit: error, device does not continue measuring. <i>Note:</i> The alarm symbol may overlie the trend symbol.
	Lock symbol The operation of the device is locked. For information on unlocking the device, see → 43 section 6.7 "Locking/unlocking operation".
	Communication symbol Data transfer via communication
	Simulation symbol Simulation mode is activated. DIP switch 2 for simulation is set to "On". See also section 6.2.1 "Position of operating elements" and → 44, section 6.8 "Simulation"
	Trend symbol (increasing) The primary value of the Pressure Transducer Block is increasing.
	Trend symbol (decreasing) The primary value of the Pressure Transducer Block is decreasing.
	Trend symbol (constant) The primary value of the Pressure Transducer Block has remained constant over the past few minutes.

6.2 Operating elements

6.2.1 Position of operating elements

With regard to aluminum housings (T14/T15), the operating key is located either outside the device under the protective cap or inside on the electronic insert. In hygienic stainless steel housings (T17), the operating key is always located inside on the electronic insert. In addition, there are three operating keys on the optional onsite display.

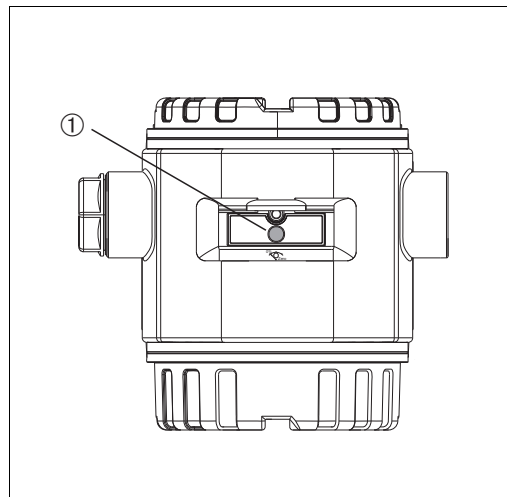

Fig. 6: External operating keys, under the protective cap

- 1 Operating key for position adjustment (zero point correction) and total reset

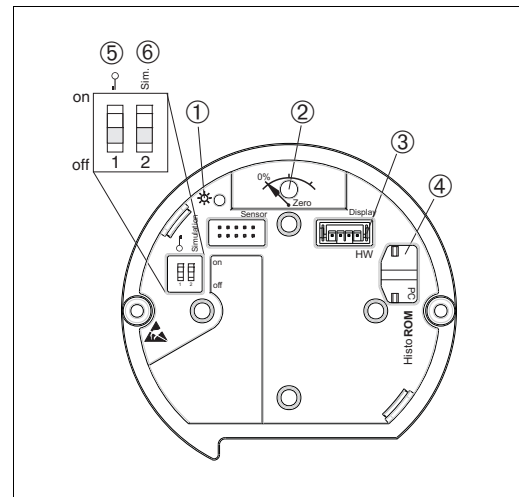
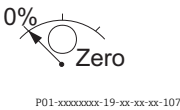
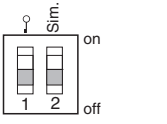

Fig. 7: Operating key and operating elements, internal

- 1 Green LED to indicate value being accepted
 2 Operating key for position adjustment (zero point correction) and total reset
 3 Slot for optional display
 4 Slot for optional HistoROM®/M-DAT
 5 DIP switch for locking/unlocking parameters relevant to the measured value
 6 DIP switch for simulation mode

6.2.2 Function of operating elements – onsite display not connected

Operating elements	Meaning
	<ul style="list-style-type: none"> - Position adjustment (zero point correction): Press key for at least 3 seconds. If the LED on the electronic insert lights up briefly, the pressure applied has been accepted for position adjustment. → See also the following Section "Performing position adjustment on site". - Total reset: Press key for at least 12 seconds. The LED on the electronic insert lights up briefly if a reset is being carried out.
	<ul style="list-style-type: none"> - DIP switch 1: for locking/unlocking measured value-related parameters. Factory setting: off (unlocked) See also → 43, section 6.7 "Locking/unlocking operation". - DIP switch 2: for simulation mode Factory setting: off (simulation mode off) → See also → 44, section 6.8 "Simulation"









Performing position adjustment on site

- Operation must be unlocked. See → 43, section 6.7 "Locking/unlocking operation".
- The device is configured for the MEASURING MODE → Level and LEVEL SELECTION → Level easy pressure as standard.
 - Operation via FF configuration program: In the Pressure Transducer Block, change the measuring mode by means of the PRIMARY_VALUE_TYPE and LINEARIZATION parameters.
 - Operation via digital communication: change the measuring mode by means of the MEASURING MODE parameter
 - You can switch measuring modes by means of the MEASURING MODE parameter.
See → 49, section 7.4 "Selecting the language and measuring mode".
- The pressure applied must be within the nominal pressure limits of the sensor.
See information on the nameplate.

Perform position adjustment:

1. Pressure is present at the device.
2. Press key for at least 3 seconds.
3. If the LED on the electronic insert lights up briefly, the pressure applied has been accepted for position adjustment.
If the LED does not light up, the pressure applied was not accepted. Observe the input limits. For error messages, see → 71, section 9.2 "Diagnostic information on onsite display".

6.2.3 Function of operating elements – onsite display connected

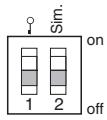
Operating key(s)	Meaning
	<ul style="list-style-type: none"> - Navigate upwards in the picklist - Edit the numerical values or characters within a function
	<ul style="list-style-type: none"> - Navigate downwards in the picklist - Edit the numerical values or characters within a function
	<ul style="list-style-type: none"> - Confirm entry - Jump to the next item
 and 	Contrast setting of onsite display: darker
 and 	Contrast setting of onsite display: brighter
 and 	<p>ESC functions:</p> <ul style="list-style-type: none"> - Exit the editing mode without saving the modified value - You are in a menu within a function group. The first time you press the keys simultaneously, you go back a parameter within the function group. Each time you press the keys simultaneously after that, you go up a level in the menu. - You are in the menu at a selection level: each time you press the keys simultaneously, you go up a level in the menu. <p><i>Note:</i> For the terms function group, level, selection level, refer to → 37, section 6.4.1</p>
 <small>P01-xxxxxxxx-19-xx-xx-xx-xx-134</small>	<ul style="list-style-type: none"> - DIP switch 1: for locking/unlocking measured value-related parameters. Factory setting: off (unlocked) - DIP switch 2: for simulation mode Factory setting: off (simulation mode off)

6.3 FOUNDATION Fieldbus interface

6.3.1 System architecture

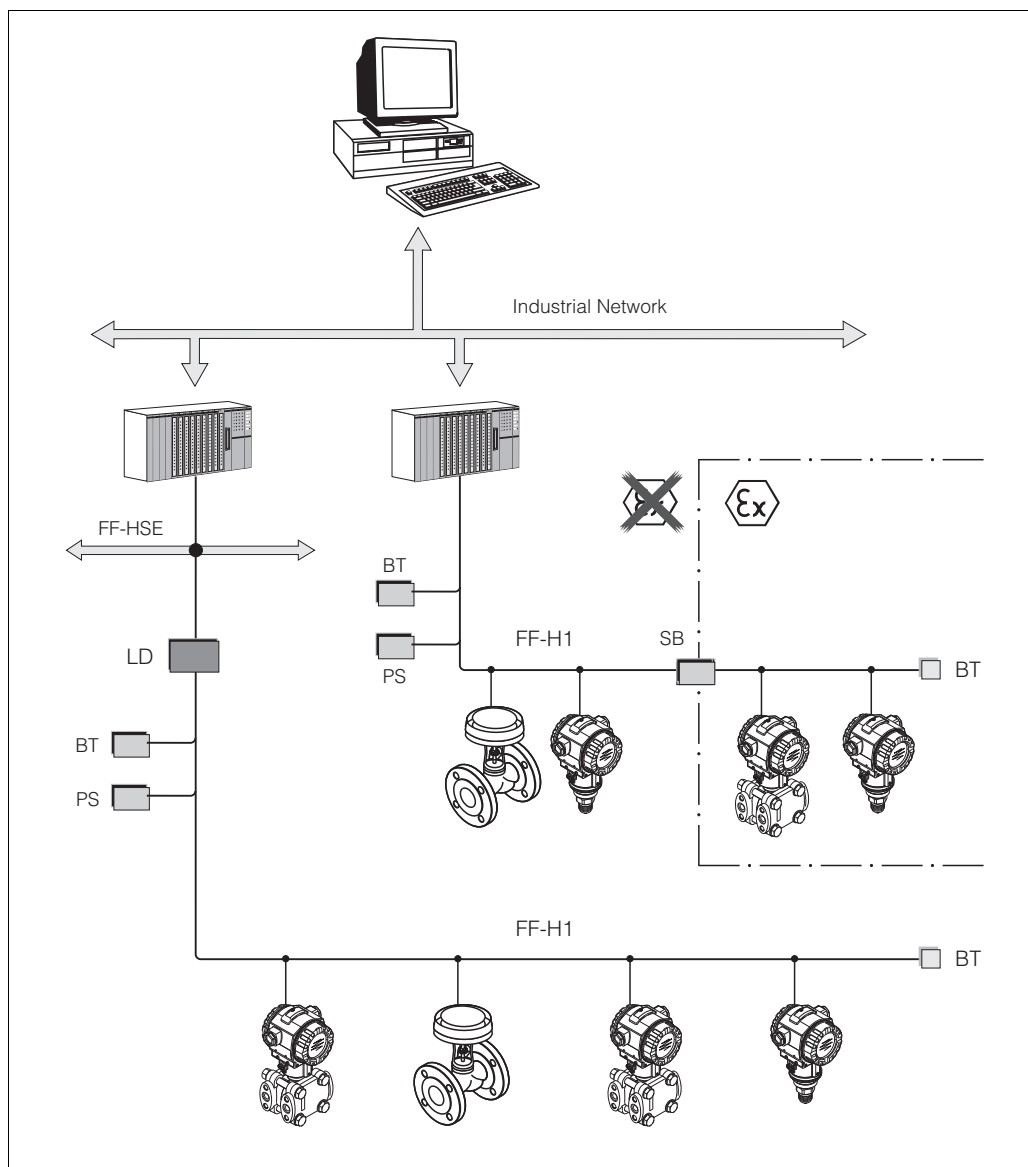

Fig. 8: FOUNDATION Fieldbus system architecture with associated components

FF-HSE: High Speed Ethernet, FF-H1: FOUNDATION Fieldbus-H1, LD: Linking Device FF-HSE/FF-H1, PS: bus power supply unit, SB: safety barrier, BT: bus terminator

The following system connection options are possible:

- A linking device makes the connection to higher-level fieldbus levels (e.g. High Speed Ethernet (HSE)) possible.
- An FF-H1 card is required to connect directly to a process control system.

Further information on FOUNDATION Fieldbus can be found in Operating Instructions BA00013S "FOUNDATION Fieldbus Overview, Installation and Commissioning Guidelines", the FOUNDATION Fieldbus Specification or on the Internet at "<http://www.fieldbus.org>".

6.3.2 Number of devices

- The Endress+Hauser Deltapilot S devices meet the requirements of the FISCO model.
- Due to the low current consumption, the following can be operated at one bus segment when installation is performed according to FISCO:
 - Up to 6 Deltapilot S devices for Ex ia, CSA and FM IS applications
 - Up to 24 Deltapilot S devices in all other applications, e.g. in non-Ex areas, Ex nA etc.

The maximum number of measuring instruments at one bus segment is defined by their current consumption, the performance of the bus coupler, and the required bus length.

6.3.3 Operation

You can obtain special configuration and operating programs from various manufacturers for the configuration, such as the FieldCare operating program from Endress+Hauser. See →  40, section 6.5 "FieldCare". These configuration programs make it possible to configure FF functions and all the device-specific parameters. The predefined function blocks allow uniform access to network and device data.

6.3.4 Network configuration

You require the following to configure a device and integrate it into an FF network:

- An FF configuration program
- The Cff file (Common File Format: *.cff, *.fhx)
- The device description (Device Description: *.sym, *.ffo, *.sy5, *.ff5)

Pre-defined standard DDs, which can be obtained from FOUNDATION Fieldbus, are available for the basic functions of measuring instruments. You require the device-specific DD to be able to access all the functions.

The files for the Deltapilot S can be acquired as follows:

- Internet Endress+Hauser: <http://www.de.endress.com> → Search for FOUNDATION Fieldbus
- Internet FOUNDATION Fieldbus: <http://www.fieldbus.org>
- On CD-ROM from Endress+Hauser, order number: 56003896

The device is integrated into the FF network as follows:

- Start the FF configuration program
- Download the Cff and device description files (*.ffo, *.sym, *.cff or *.fhx files) to the system
- Configure the interface, see Note
- Configure the device for the measuring task and for the FF system
- For more in-depth information on integrating the device into the FF system, see the description for the configuration software used.
- When integrating the field devices into the FF system, make sure you are using the right files. You can read out the required version by means of the DEV_REV and DD_REV parameters in the Resource Block.

6.3.5 Device identification and addressing

FOUNDATION Fieldbus identifies the device using its ID code and automatically assigns it a suitable field address. The identity code cannot be changed.

The device appears in the network display once you have started the FF configuration program and integrated the device into the network. The blocks available are displayed under the device name.

If the device description has not yet been loaded, the blocks report "Unknown" or "(UNK)".

The Deltapilot S reports as follows:

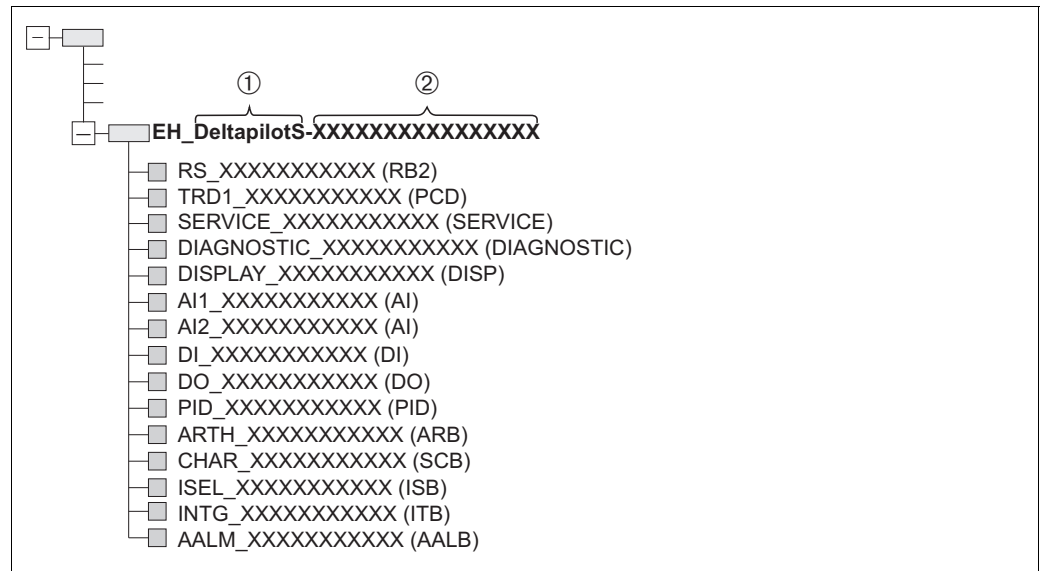

Fig. 9: Typical Deltapilot S display in a configuration program after the connection has been established

- 1 Device name
2 Serial number

6.3.6 Deltapilot S block model

With FOUNDATION Fieldbus, all the device parameters are categorized according to their functional properties and task and are generally assigned to three different blocks.

A FOUNDATION Fieldbus device has the following block types:

- A Resource Block (device block):
This block contains all the device-specific features of the device.
- One or more Transducer Blocks
A Transducer Block contains all the measuring and device-specific parameters of the device. The measuring principles, such as pressure or totalizers, are mapped in the Transducer Blocks.
- One or more function blocks:
Function blocks contain the automation functions of the device. A distinction is made between different function blocks such as the Analog Input Block or Proportional Integral Differential Block. Each of these function blocks is used to execute different application functions.

The function blocks can be connected by means of an FF configuration program, depending on the automation task. The device thus takes on simple control functions, thereby relieving the workload on the higher-order process control system.

The Deltapilot S has the following blocks:

- Resource Block (device block)
- 4 Transducer Blocks
 - Pressure Transducer Block (TRD)

This Block supplies the output variables PRIMARY_VALUE and SECONDARY_VALUE. It contains all the parameters to configure the measuring instrument for the measuring task such as measuring mode selection, linearization function and unit selection.
 - Service Transducer Block

This Block supplies the output variables COUNTER_P_PMAX, PRESSURE_1_MAX_RESETTABLE and PRESSURE_1_AFTER_DAMPING. It also includes all the counters for measuring range overshoot/undershoot for pressure and temperature, minimum and maximum measured values for pressure and temperature and the HistoROM function.
 - Display Transducer Block

This Block does not return any output variables. It contains all the parameters for configuring the onsite display such as DISPLAY_CONTRAST.
 - Diagnostic Transducer Block

This Block does not return any output variables. It contains

 - the simulation function for the Pressure Transducer Block
 - parameters to configure the alarm response
 - parameters to set the user limits for pressure and temperature.
- 8 function blocks
 - 2 Analog Input Blocks (AI)
 - Discrete Input Block (DI)
 - Discrete Output Block (DO)
 - PID Block (PID)
 - Arithmetic Block (ARB)
 - Signal Characterizer Block (SCB)
 - Input Selector Block (ISB)
 - Analog Alarm Block (AALB)
 - Integrator Block (IT)

In addition to the pre-instanced blocks already mentioned, the following blocks can also be instanced:

- 3 Analog Input Blocks (AI)
- 1 Discrete Output Block (DO)
- 1 PID Block (PID)
- 1 Arithmetic Block (ARB)
- 1 Signal Characterizer Block (SCB)
- 1 Input Selector Block (ISB)
- 1 Analog Alarm Block (AALB)
- 1 Integrator Block (IT)

A total of 20 blocks can be instanced in the Deltapilot S altogether, including the blocks already instanced. For information on instancing blocks, see the appropriate Operating Instructions of the configuration program used.

Endress+Hauser Guideline BA00062S.

The guideline provides an overview of the standard function blocks that are described in FOUNDATION Fieldbus Specifications FF 890 - 894.

It is designed as an aid when using these blocks that are implemented in the Endress+Hauser field devices.

Default (as-delivered) block configuration

The block model shown below illustrates the block configuration when the device is delivered.

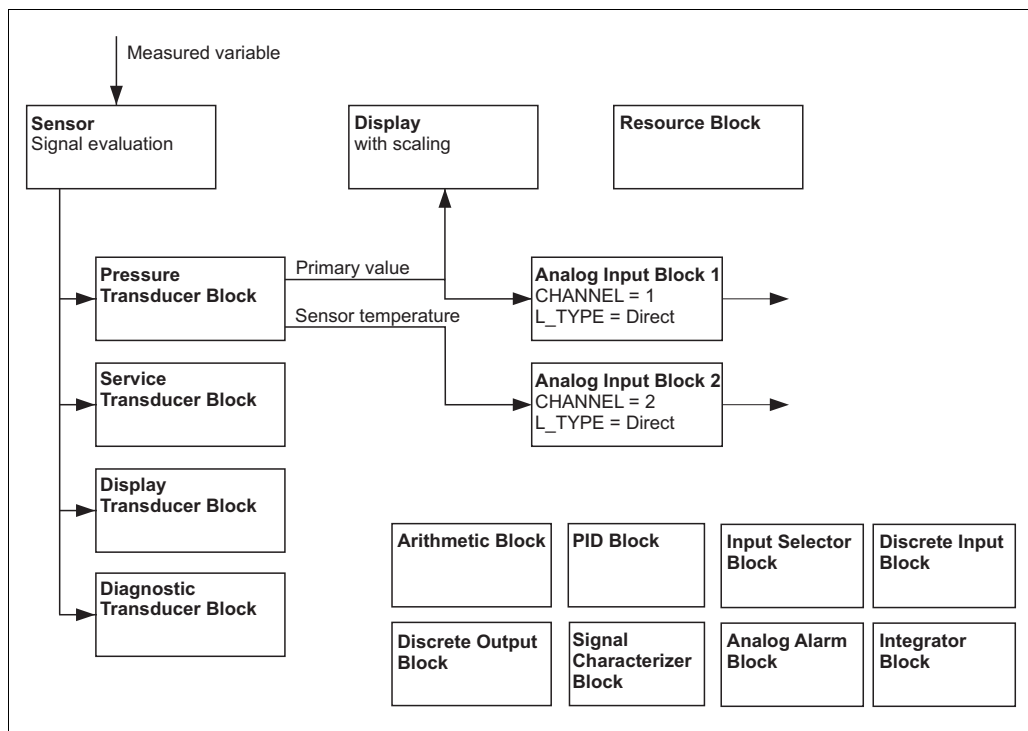

P01-PMx7xxxx-02-xx-xx-en-006

Fig. 10: Default (as-delivered) block configuration

The Pressure Transducer Block supplies the Primary Value and the sensor temperature (Secondary Value). The Primary Value and Secondary Value are each transferred to an Analog Input Block by means of the CHANNEL parameter (→ see also the following section). The Discrete Output, Discrete Input, PID, Arithmetic, Signal Characterizer, Input Selector, Integrator and Analog Alarm Block are not connected in the as-delivered configuration.

⚠ CAUTION

Note Dependencies when setting parameters!

- ▶ Please note that the links between the blocks are deleted and the FF parameters are reset to the default values following a reset by means of the RESTART parameter in the Resource Block, "Default" option.

6.3.7 Assignment of Transducer Blocks (CHANNEL)

Settings for the Analog Input Block

Process variable	Transducer Block	Parameter name	CHANNEL parameter in the Analog Input Block
Primary Value, a pressure or level value depending on the measuring mode ¹⁾	Pressure Transducer Block	PRIMARY_VALUE/ MEASURED VALUE	1
Secondary Value (sensor temperature) ²⁾		MEASURED_TEMPERA TURE/TEMP. SENSOR	2
Pressure after damping	Service Transducer Block	PRESSURE_1_AFTER_ DAMPING/ PRESSURE	3
Maximum measured pressure		PRESSURE_1_MAX_ RESTABLE/ MAX. MEAS. PRESS.	4
Overshoot counter for maximum set user limit for pressure		COUNTER:P > Pmax	5

1) Factory setting for Analog Input Block 1

2) Factory setting for Analog Input Block 2

Settings for the Discrete Output Block

Process variable	Transducer Block	Parameter name	CHANNEL parameter in the Discrete Output Block
Overshoot counter for maximum set user limit for pressure ¹⁾	Service Transducer Block	COUNTER:P > Pmax	1

1) Factory setting

Discrete Input Block settings

Alarm conditions	Transducer Block	Parameter name	Parameter CHANNEL, Discrete Input Block
General device error	Diagnostic Transducer Block	DIAGNOSTIC_CODE	1
Configuration error			2
Sensor over pressure			3
Sensor low pressure			4
Sensor over temperature			5
Sensor under temperature			6
Process membrane broken			7
Electronic overtemperature			8
Electronic undertemperature			9
Temperature transmitter override			10
Pressure measured value overrange			11
Pmin PROCESS underrun			12
Pmax PROCESS overrun			13
Tmin PROCESS underrun			14
Tmax PROCESS overrun			15

6.3.8 Index tables of Endress+Hauser parameters

The following tables list the manufacturer-specific device parameters for the Resource Block, the Transducer Blocks and the Analog Input Blocks. For the FF parameters, see either the FF specification or Operating Instructions BA00303P "Description of Device Functions, Cerabar S/ Deltabar S/ Deltapilot S". These parameters are not displayed in the block view in FieldCare (exception: Analog Input Blocks).

General explanatory remarks

Data type

- DS: data structure, contains data types such as unsigned8, octet string etc.
- Bit enumerated
- Float: IEEE 754 format
- Visible String: ASCII coded
- Unsigned:
 - Unsigned8: value range = 0 to 255
 - Unsigned16: value range = 0 to 65535

Storage Class

- D: dynamic parameter
- N: non-volatile parameter
- S: static parameter

If this is a write parameter, the MODE_BLK column indicates the block mode in which the parameter can be written. Some parameters can only be written in the OOS block mode. The "Reset codes" column indicates which reset codes reset the parameter.

Resource block

Parameter name, option "Symbolic name"	Parameter name, option "Label"	Index	Data type	Size [byte]	Storage Class	Read	Write	MODE_BLK	Reset codes
ENP_VERSION	ENP version	44	Visible String	16	S	x			
DEVICE_TAG	Device tag	45	Visible String	32	S	x	x ¹⁾	AUTO, OOS	
SERIAL_NUMBER	Serial number	46	Visible String	16	S	x	x ¹⁾	AUTO, OOS	
ORDER_CODE	Order number	47	Visible String	32	S	x	x ¹⁾	AUTO, OOS	
FIRMWARE_VERSION	Firmware version	48	Visible String	16	S	x			
SW_LOCK	INSERT PIN No	49	Unsigned16	2	S	x	x	AUTO, OOS	7864, 333
STATUS_LOCKING	Status locking	50	Unsigned16	2	D	x			
HARDWARE_REVISION	Hardware rev.	74	Visible String	16	S	x			
FF_COMM_VERSION	FF comm. version	75	Visible String	16	S	x			
BLOCK_ERR_DESC_1	Block Error desc.	76	Bit enumerated	4	D	x			
DEVICE_DIALOG	Device dialog	77	Unsigned8	1	D	x			
ELECTRONIC_SERIAL_NUMBER	Electr. serial no.	78	Visible String	16	S	x			
PROCESS_CONNECTION_TYPE	Proc. conn. type	79	Unsigned16	2	S	x	x	AUTO, OOS	7864, 333
MAT_PROC_CONN_POS	Mat. proc. conn. +	80	Unsigned16	2	S	x	x	AUTO, OOS	7864, 333
MAT_PROC_CONN_NEG	Mat. proc. conn. -	81	Unsigned16	2	S	x	x	AUTO, OOS	7864, 333
SEAL_TYPE	Seal type	82	Unsigned16	2	S	x	x	AUTO, OOS	7864, 333
SCI_OCTET_STRING	SCI_OCTET_STR	83	Visible String	40	S	x	x	AUTO, OOS	
MS_RESOURCE_DIRECTORY	RESOURCE DIRECTORY	84	Unsigned16	20x2	S	x			

1) Can be written with service code

Pressure Transducer Block

Parameter name, option "Symbolic name"	Parameter name, option "Label"	Index	Data type	Size [byte]	Storage Class	Read	Write	MODE_BLK	Reset codes
MEASURED_TEMPERATURE	Temperature	32	DS-65	5	D	x			
MEASURED_TEMPERATURE_UNIT	Temp. eng. unit	33	Unsigned16	2	S	x	x	OOS	
DEVICE_DIALOG	Device dialog	34	Unsigned8	1	D	x			
SW_LOCK	Insert PIN No.	35	Unsigned16	2	S	x	x	AUTO, OOS, MAN	7864, 333
STATUS_LOCKING	Status locking	36	Unsigned16	2	D	x			
LINEARIZATION	Linearization	37	Unsigned8	2	S	x	x	OOS	7864, 333
SCALE_IN	Scale In	38	DS-68	11	S	x	x	OOS	7864, 333
SCALE_OUT	Scale Out	39	DS-68	11	S	x	x	OOS	7864, 333
DAMPING_VALUE	Damping value	40	Float	4	S	x	x	OOS	7864, 333
ZERO_POSITION_ADJUST	Pos. zero adjust	41	Unsigned8	1	D	x	x	OOS	
POSITION_INPUT_VALUE	Pos. input value	42	Float	4	S	x	x	OOS	7864, 333, 2509
CALIBRATION_OFFSET	Calib. offset	43	Float	4	S	x	x	OOS	7864, 333, 2509
CUSTOMER_UNIT_PRESSURE	Customer unit P	44	Visible String	8	S	x	x	AUTO, OOS, MAN	7864
CUSTOMER_FACTOR_UNIT_PRESS	Cust. unit. fact. P	45	Float	4	S	x	x	OOS	7864
LOW_TRIM_MEASURED	Lo trim measured	46	Float	4	S	x			2509
HIGH_TRIM_MEASURED	Hi trim measured	47	Float	4	S	x			2509
LEVEL_MODE	Level mode	48	Unsigned8	1	S	x	x	OOS	7864, 333
LINEAR_MEASURAND	Lin. measurand	49	Unsigned8	1	S	x	x	OOS	7864, 333
LINEARIZED_MEASURAND	Lin. measurand	50	Unsigned8	1	S	x	x	OOS	7864, 333
COMBINED_MEASURAND	Comb. measurand	51	Unsigned8	1	S	x	x	OOS	7864, 333
DENSITY_UNIT	Density unit	52	Unsigned16	2	S	x	x	OOS	7864, 333
HEIGHT_UNIT	Height unit	53	Unsigned16	2	S	x	x	OOS	7864, 333
CUSTOMER_HEIGHT_UNIT	Customer unit H	54	Visible String	8	S	x	x	AUTO, OOS, MAN	7864
CUSTOMER_UNIT_FACTOR_HEIGHT	Cust. unit. fact. H	55	Float	4	S	x	x	OOS	7864
VOLUME_UNIT	Unit volume	56	Unsigned16	2	S	x	x	OOS	7864, 333
CUSTOMER_UNIT_VOLUME	Customer unit V	57	Visible String	8	S	x	x	AUTO, OOS, MAN	7864
CUSTOMER_UNIT_FACTOR_VOLUME	Cust. unit. fact. V	58	Float	4	S	x	x	OOS	7864
MASS_UNIT	Unit mass	59	Unsigned16	2	S	x	x	OOS	7864, 333
CUSTOMER_UNIT_MASS	Customer unit M	60	Visible String	8	S	x	x	AUTO, OOS, MAN	7864
CUSTOMER_UNIT_FACTOR_MASS	Cust. unit. fact. M	61	Float	8	S	x	x	OOS	7864
CALIBRATION_MODE	Calibration mode	62	Unsigned8	1	S	x	x	OOS	7864, 333
ADJUST_DENSITY	Adjust density	63	Float	4	S	x	x	OOS	7864, 333
ZERO_POSITION	Zero position	64	Float	4	S	x	x	OOS	7864, 333
EMPTY_CALIBRATION	Empty calibration	65	Float	4	S	x	x	OOS	7864, 333
FULL_CALIBRATION	Full calibration	66	Float	4	S	x	x	OOS	7864, 333
TANK_VOLUME	Tank volume	67	Float	4	S	x	x	OOS	7864, 333
TANK_HEIGHT	Tank height	68	Float	4	S	x	x	OOS	7864, 333
HUNDRED_PERCENT_VALUE	100% point	69	Float	4	S	x	x	OOS	7864, 333
LEVEL_MIN	Level Min.	70	Float	4	S	x	x	OOS	7864, 333
LEVEL_MAX	Level max.	71	Float	4	S	x	x	OOS	7864, 333
PROCESS_DENSITY	Process density	72	Float	4	S	x	x	OOS	7864, 333
LINEARIZATION_TABLE_SELECTION	Table selection	73	Unsigned8	1	S	x	x	AUTO, OOS, MAN	7864, 333
LINEARIZATION_EDIT_MODE	Lin. edit mode	74	Unsigned8	1	S	x	x	AUTO, OOS, MAN	7864
LINEARIZATION_TABLE_PRE_EDIT	Table editor	75	Unsigned8	1	D	x	x	AUTO, OOS, MAN	
LINEARIZATION_TABLE_INDEX	Line numb:	76	Unsigned8	1	D	x	x	AUTO, OOS, MAN	
LINEARIZATION_TABLE_X_VALUE	X-value:	77	Float	4	S	x	x	AUTO, OOS, MAN	7864
LINEARIZATION_TABLE_Y_VALUE	Y-value:	78	Float	4	S	x	x	AUTO, OOS, MAN	7864
LINEARIZATION_TABLE_POST_EDIT	Table editor	79	Unsigned8	1	D	x	x	OOS	
LINEARIZATION_TABLE_POST_VIEW	Measuring table	80	Unsigned8	1	D	x	x	AUTO, OOS, MAN	
LEVEL_TANK_DESCRIPTION	Tank description	81	Visible String	32	S	x	x	AUTO, OOS, MAN	7864
SENSOR_PRESSURE	Sensor pressure	82	Float	4	D	x			
PRESSURE	Pressure	83	Float	4	D	x			
LEVEL_BEFORE_LINEARIZATION	Level before lin	84	Float	4	D	x			

Parameter name, option "Symbolic name"	Parameter name, option "Label"	Index	Data type	Size [byte]	Storage Class	Read	Write	MODE_BLK	Reset codes
SENSOR_MEAS_TYPE	Sensor meas. type	85	Unsigned16	2	D	x			
LEVEL_SELECTION	Level selection	86	Unsigned8	1	S	x	x	OOS	7864, 333
HEIGHT_UNIT_EASY	Height unit	87	Unsigned16	2	S	x	x	OOS	
OUTPUT_UNIT_EASY	Output Level Easy	88	Unsigned16	2	S	x	x	OOS	
CALIBRATION_MODE_EASY	Calibration mode	89	Unsigned8	1	S	x	x	OOS	7864, 333
DENSITY_UNIT_EASY	Density unit	90	Unsigned16	2	S	x	x	OOS	
ADJUST_DENSITY_EASY	Adjust density	91	Float	4	S	x	x	OOS	7864, 333
EMPTY_HEIGHT_EASY	Empty height level easy	92	Float	4	S	x	x	OOS	7864, 333
FULL_HEIGHT_EASY	Full height level easy	93	Float	4	S	x	x	OOS	7864, 333
PROCESS_DENSITY_EASY	Process density	94	Float	4	D	x	x	OOS	7864, 333
MEASURED_LEVEL_EASY	Meas. level easy	95	Float	4	D	x			
FULL_CALIBRATION_EASY	Full calib. level easy	96	Float	4	S	x	x	OOS	7864, 333
EMPTY_CALIBRATION_EASY	Empty calib. level easy	97	Float	4	S	x	x	OOS	7864, 333
FULL_PRESSURE_EASY	Full pressure level easy	98	Float	4	S	x	x	OOS	7864, 333
EMPTY_PRESSURE_EASY	Empty pressure level easy	99	Float	4	S	x	x	OOS	7864, 333

Service Transducer Block

Parameter name, option "Symbolic name"	Parameter name, option "Label"	Index	Data type	Size [byte]	Storage Class	Read	Write	MODE_BLK	Reset codes
DEVICE_DIALOG	Device dialog	11	Unsigned8	1	D	x			
SW_LOCK	Insert PIN No.	12	Unsigned16	2	S	x	x	AUTO, OOS, MAN	7864, 333
STATUS_LOCKING	Status locking	13	Unsigned16	2	D	x			
CONFIGURATION_COUNTER	Config recorder	14	Unsigned16	2	S	x			
ELECTRONICS_TEMPERATURE	Pcb temperature	15	Float	4	D	x			
ELECTRONICS_TEMP_LOW_LIMIT	Allowed min. TEMP	16	Float	4	S	x			
ELECTRONICS_TEMP_HIGH_LIMIT	Allowed Max. TEMP	17	Float	4	S	x			
PMAX_PROC_CONN	Pmax PROC. CONN.	18	Float	4	S	x	x	AUTO, OOS, MAN	
SENSOR_MEAS_TYPE	Sensor meas. type	19	Unsigned16	2	S	x			
SENSOR_MIN_ABSOLUTE_LIMIT	Pmin sensor damage	20	Float	4	S	x			
SENSOR_MAX_ABSOLUTE_LIMIT	Pmax sensor damage	21	Float	4	S	x			
SENSOR_TEMP_LOW_LIMIT	Tmin sensor	22	Float	4	S	x			
SENSOR_TEMP_HIGH_LIMIT	Tmax sensor	23	Float	4	S	x			
SENSOR_HARDWARE_REV	Sensor H/ware rev.	24	Unsigned8	1	S	x			
COUNTER_P_MAX	Counter: P > Pmax	25	DS-65	5	D	x			
MAX_MEASURED_PRESSURE	Max. meas. press.	26	DS-65	5	D	x			
COUNTER_PMIN	Counter: P < Pmin	27	Unsigned16	2	D	x			
MIN_MEASURED_PRESSURE	Min. meas. press.	28	Float	4	D	x			
COUNTER_TMAX	Counter: T > Tmax	29	Unsigned16	2	D	x			
MAX_MEASURED_TEMP	Max. meas. temp.	30	Float	4	D	x			
COUNTER_TMIN	Counter: T < Tmin	31	Unsigned16	2	D	x			
MIN_MEASURED_TEMP	Min. meas. temp.	32	Float	4	D	x			
ELECTRONIC_OVER_TEMP_COUNTER	Pcb count: T > Tmax	33	Unsigned16	2	D	x			
ELECTRONIC_OVER_TEMPERATURE	Pcb max. temp	34	Float	4	D	x			
ELECTRONIC_UNDER_TEMP_COUNTER	Pcb count: T < Tmin	35	Unsigned16	2	D	x			
ELECTRONIC_UNDER_TEMPERATURE	PCB min. temp.	36	Float	4	D	x			
RESET_PEAK_HOLD	Reset peakhold	37	Unsigned8	1	D	x	x	AUTO, OOS, MAN	
PRESSURE	Pressure	38	DS-65	5	D	x			
CORRECTED_PRESSURE	Corrected press.	39	Float	4	D	x			
MEASURED_VALUE_TREND	Meas. val. trend	40	Unsigned8	1	D	x			
MAX_TURNDOWN	Max. turndown	41	Float	4	S	x	x ¹⁾		
SENSOR_CHANGES	Sensor changes	42	Unsigned16	2	S	x	x ¹⁾		
PRESSURE_PEAK_HOLD_STEP	P. peakhold step	43	Float	4	S	x	x ¹⁾		
TEMP_PEAK_HOLD_STEP	T. peakhold step	44	Float	4	S	x	x ¹⁾		
ACCELERATION_OF_GRAVITY	Acc. of gravity	45	Float	4	S	x	x ¹⁾	OOS	
HISTOROM_SAVING_CYCLE_TIME	Hist. saving cycl	47	Unsigned8	1	S	x	x ¹⁾		
HISTOROM_AVAILABLE	Historom avail.	48	Unsigned8	1	S	x			
DOWNLOAD_SELECTION	Download select.	49	Unsigned8	1	D	x	x	AUTO, OOS, MAN	
HISTOROM_CONTROL	Historom control	50	Unsigned8	1	D	x	x		
PRESSURE_UNIT	Pressure eng. unit	51	Unsigned16	2	S	x			
TEMPERATURE_UNIT	Temp. eng. unit	52	Unsigned16	2	S	x			
INPUT_PRESSURE_INVERSION	Inp. press invers	53	Unsigned8	1	S	x	x ¹⁾	OOS	

1) Can be written with service code

Display Transducer Block

Parameter name, option "Symbolic name"	Parameter name, option "Label"	Index	Data type	Size [byte]	Storage Class	Read	Write	BLK_MODE	Reset codes
DEVICE_DIALOG	Device dialog	10	Unsigned8	1	D	x			
DISPLAY_MAINLINE_CONTENT	Main line cont.	11	Unsigned8	1	S	x	x	AUTO, OOS, MAN	7864
DISPLAY_MAINLINE_FORMAT	Main data format	12	Unsigned8	1	S	x	x	AUTO, OOS, MAN	7864
DISPLAY_ALTERNATING_VALUES	Alternate data	13	Unsigned8	1	S	x	x	AUTO, OOS, MAN	7864
DISPLAY_CONTRAST	Display contrast	14	Unsigned8	1	S	x	x	AUTO, OOS, MAN	7864
DISPLAY_LANGUAGE	Language	15	Unsigned8	1	S	x	x	AUTO, OOS, MAN	7864
SIL_DIGITS_TEST_STRING	Digits set	16	Visible String	16	D	x			

Diagnostic Transducer Block

Parameter name, option "Symbolic name"	Parameter name, option "Label"	Index	Data type	Size [byte]	Storage Class	Read	Write	BLK_MODE	Reset codes
DEVICE_DIALOG	Device dialog	10	Unsigned8	1	D	x			
SW_LOCK	Insert PIN No.	11	Unsigned16	2	S	x	x	AUTO, OOS, MAN	7864, 333
STATUS_LOCKING	Status locking	12	Unsigned16	2	D	x			
SIMULATION_MODE	Simulation	13	Unsigned8	1	D	x	x	OOS	
SCALE_OUT_UNITS_INDEX	Units index	14	Unsigned16	2	S	x			
SIMULATED_VALUE	Simulated value	15	Float	4	D	x	x	AUTO, OOS, MAN	
SIMULATION_ERROR_NUMBER	Sim. error no.	16	Unsigned16	2	D	x	x	AUTO, OOS, MAN	
ALARM_STATUS	-	17	Unsigned16	2	D	x			
ALARM_STATUS_WITH_CATEGORY	Alarm status info	18	Unsigned16	2	D	x			
LAST_DIAGNOSTIC_CODE	-	19	Unsigned16	2	D	x			
LAST_DIAGNOSTIC_CODE_WITH_CATEGORY	Last diag. code info	20	Unsigned16	2	D	x			
ACKNOWLEDGE_ALARM_MODE	Ack. alarm mode	21	Unsigned8	1	S	x	x	AUTO, OOS, MAN	7864
ACKNOWLEDGE_ALARM	Ack. alarm	22	Unsigned8	1	D	x	x	AUTO, OOS, MAN	
RESET_ALL_ALARMS	Reset all alarms	23	Unsigned8	1	D	x	x	AUTO, OOS, MAN	
ERROR_NUMBER	Error no.	24	Unsigned16	2	D	x	x	AUTO, OOS, MAN	
SELECT_ALARM_TYPE	Select alarm type	25	Unsigned8	1	D	x	x	AUTO, OOS, MAN	
ALARM_DELAY	Alarm delay	26	Float	4	S	x	x	AUTO, OOS, MAN	7864
ALARM_DISPLAY_TIME	Alarm displ. time	27	Float	4	S	x	x	AUTO, OOS, MAN	7864
PRESSURE_UNIT	Press. eng. unit	28	Unsigned16	2	S	x			7864, 333
PMIN_ALARM_WINDOW	Pmin alarm window	29	Float	4	S	x	x	AUTO, OOS, MAN	7864
PMAX_ALARM_WINDOW	Pmax alarm window	30	Float	4	S	x	x	AUTO, OOS, MAN	7864
TEMPERATURE_UNIT	Temp. eng. unit	31	Unsigned16	2	S	x			7864, 333
TMIN_ALARM_WINDOW	Tmin. alarm window	32	Float	4	S	x	x	AUTO, OOS, MAN	7864
TMAX_ALARM_WINDOW	Tmax. alarm window	33	Float	4	S	x	x	AUTO, OOS, MAN	7864
ENTER_RESET_CODE	Enter reset code	34	Unsigned16	2	D	x	x	AUTO, OOS, MAN	
OPERATING_HOURS	Operating hours	35	Unsigned32	4	D	x			
STATUS_HISTORY	Alarm history	36	Visible String	18	D	x			
HIGHEST_CATEGORY	-	37	Unsigned8	1	D	x			
FF912_CONFIG_AREA	FF912ConfigArea	38	DS271	30	S	x	x	AUTO, OOS, MAN	7864
FF912_STATUS_SELECT1	Status Select Event 115	39	Enumerated	1	S	x	x	AUTO, OOS, MAN	7864
FF912_STATUS_SELECT2	Status Select Event 120	40	Enumerated	1	S	x	x	AUTO, OOS, MAN	7864
FF912_STATUS_SELECT3	Status Select Event 715	41	Enumerated	1	S	x	x	AUTO, OOS, MAN	7864

Parameter name, option "Symbolic name"	Parameter name, option "Label"	Index	Data type	Size [byte]	Storage Class	Read	Write	BLK_MODE	Reset codes
FF912_STATUS_SELECT4	Status Select Event 717	42	Enumerated	1	S	x	x	AUTO, OOS, MAN	7864
FF912_STATUS_SELECT5	Status Select Event 718	43	Enumerated	1	S	x	x	AUTO, OOS, MAN	7864
FF912_STATUS_SELECT6	Status Select Event 720	44	Enumerated	1	S	x	x	AUTO, OOS, MAN	7864
FF912_STATUS_SELECT7	Status Select Event 726	45	Enumerated	1	S	x	x	AUTO, OOS, MAN	7864
FF912_STATUS_SELECT8	Status Select Event 727	46	Enumerated	1	S	x	x	AUTO, OOS, MAN	7864
FF912_STATUS_SELECT9	Status Select Event 730	47	Enumerated	1	S	x	x	AUTO, OOS, MAN	7864
FF912_STATUS_SELECT10	Status Select Event 731	48	Enumerated	1	S	x	x	AUTO, OOS, MAN	7864
FF912_STATUS_SELECT11	Status Select Event 732	49	Enumerated	1	S	x	x	AUTO, OOS, MAN	7864
FF912_STATUS_SELECT12	Status Select Event 733	50	Enumerated	1	S	x	x	AUTO, OOS, MAN	7864
FF912_STATUS_SELECT13	Status Select Event 740	51	Enumerated	1	S	x	x	AUTO, OOS, MAN	7864

Analog Input Blocks

Parameter name, option "Symbolic name"	Parameter name, option "Label"	Index	Data type	Size [byte]	Storage Class	Read	Write	BLK_MODE	Reset codes
FSAFE_TYPE	Fsafe_Type	37	Unsigned8	1	S	x	x	OOS, MAN	
FSAFE_VALUE	Fsafe_Value	38	Float	4	S	x	x	AUTO, OOS, MAN	
HIHI_ALM_OUT_D	High high alarm output discrete	39	DS66	2	D	x	x	AUTO, OOS, MAN	
HI_ALM_OUT_D	High Alarm Output Discrete	40	DS66	2	D	x	x	AUTO, OOS, MAN	
LO_ALM_OUT_D	Low Alarm Output Discrete	41	DS66	2	D	x	x	AUTO, OOS, MAN	
LOLO_ALM_OUT_D	Low Low Alarm Output Discrete	42	DS66	2	D	x	x	AUTO, OOS, MAN	
ALARM_MODE	Select Alarm Mode	43	Unsigned8	1	S	x	x	AUTO, OOS, MAN	
ALARM_OUT_D	Alarm Output Discrete	44	DS66	2	D	x	x	AUTO, OOS, MAN	
BLOCK_ERR_DESC_1	Block Error Description	45	Unsigned32	4	D	x		AUTO, OOS, MAN	

6.3.9 Methods

The FOUNDATION Fieldbus Specification includes the use of methods to make device operation easier. A method is a sequence of interactive steps to be carried out in the specified order so as to configure certain device functions.

The following methods are available for the Deltapilot S:

- Restart (Resource Block)
- Troubleshooting information, Config. Error No, Alarm Table (Diagnostic Block)
- HistoROM (Service Block)
- Sensor Trim (TRD Block)

For further information on accessing methods, see the description of the FF configuration program used.

6.4 Onsite operation – onsite display connected

If the onsite display is connected, the three operating keys are used to navigate through the operating menu, → 24, section 6.2.3 "Function of operating elements – onsite display connected".

6.4.1 Menu structure

The menu is split into four levels. The three upper levels are used to navigate while you use the bottom level to enter numerical values, select options and save settings. The structure of the OPERATING MENU depends on the measuring mode selected, e.g. if the "Pressure" measuring mode is selected, only the functions necessary for this mode are displayed.

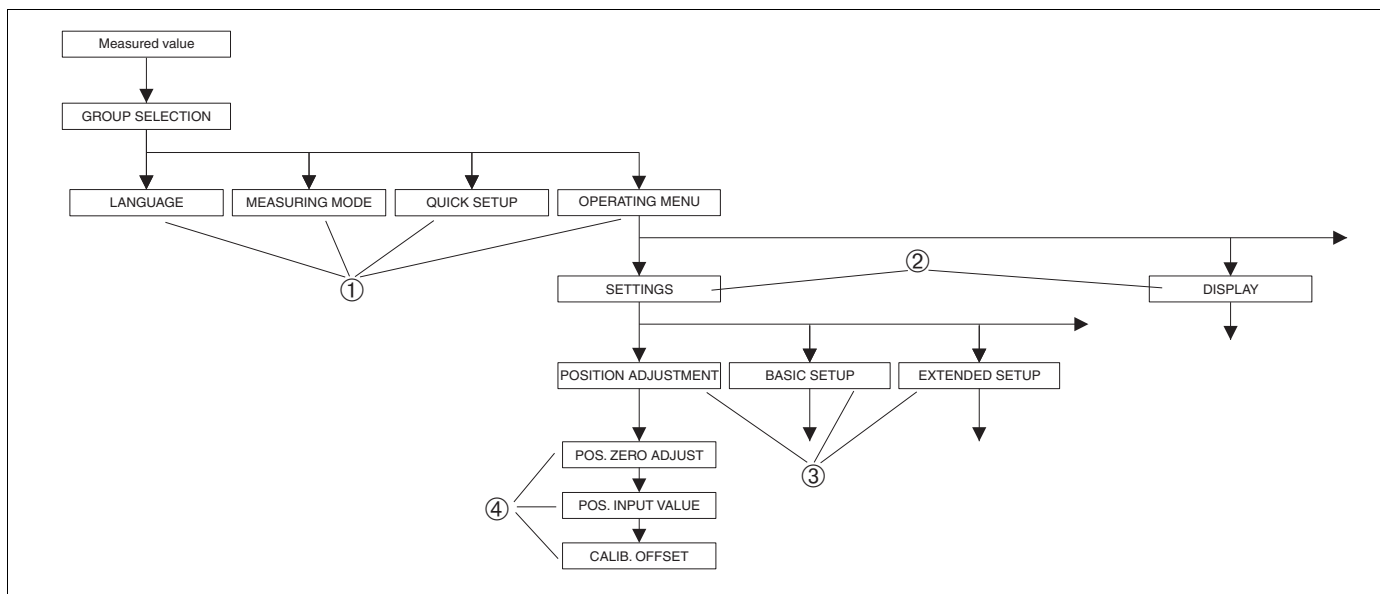

Fig. 11: Menu structure

- 1 1st selection level
- 2 2nd selection level
- 3 Function groups
- 4 Parameters

The MEASURING MODE parameter is only displayed via the onsite display on the 1st selection level. In FieldCare, the LANGUAGE parameter is displayed in the DISPLAY group and the parameters for configuring the measuring mode are displayed in the Measuring Mode menu.

6.4.2 Selecting an option

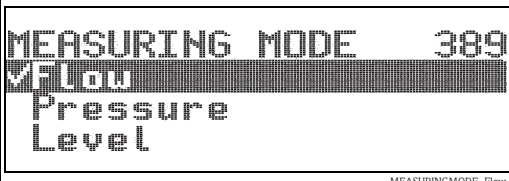
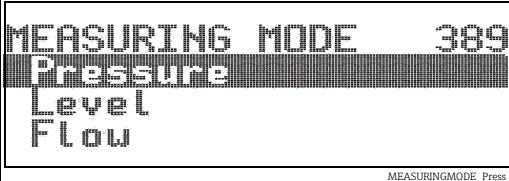
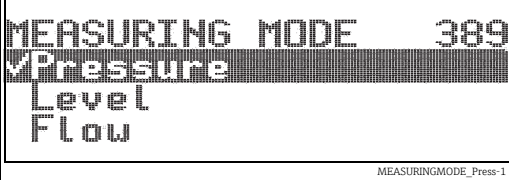

Example: Selecting the "Pressure" measuring mode.

Onsite display	Operation
 <p>MEASURING MODE 389 VALU Pressure Level</p> <p style="text-align: right;"><small>MEASURINGMODE_Flow</small></p>	"Level" has been selected as the measuring mode. A ✓ in front of the menu text indicates the option that is currently active.
 <p>MEASURING MODE 389 Pressure Level Flow</p> <p style="text-align: right;"><small>MEASURINGMODE_Press</small></p>	Use "+" or "-" to select "Pressure" as the operating mode.
 <p>MEASURING MODE 389 ✓ Pressure Level Flow</p> <p style="text-align: right;"><small>MEASURINGMODE_Press-1</small></p>	<ol style="list-style-type: none"> 1. Confirm your choice with "E". A ✓ in front of the menu text indicates the option that is currently active. (The "Pressure" measuring mode is selected.) 2. Jump to the next item with "E".

6.4.3 Editing a value

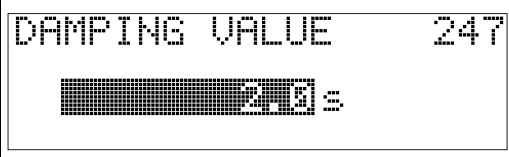
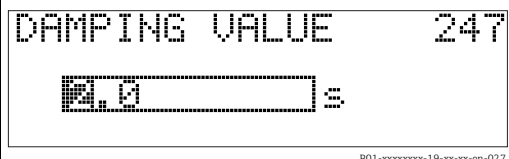
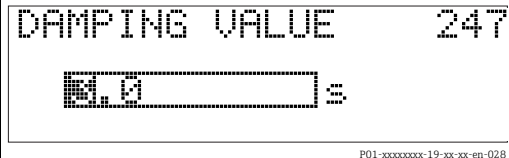
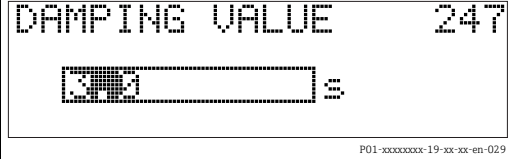

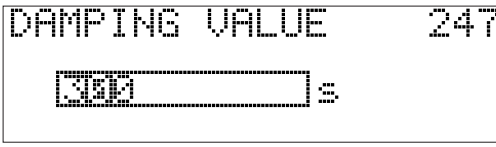
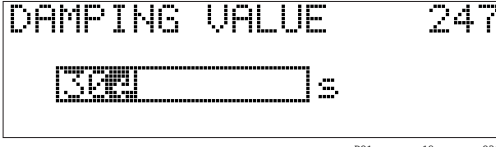
Example: adjusting DAMPING VALUE function from 2.0 s to 30.0 s. See also → 24, section 6.2.3 "Function of operating elements – onsite display connected".

Onsite display	Operation
 <p>DAMPING VALUE 247 2.0 s</p> <p style="text-align: right;"><small>P01-xxxxxxx-19-xx-xx-en-023</small></p>	The onsite display shows the parameter to be changed. The value highlighted in black can be changed. The "s" unit is fixed and cannot be changed.
 <p>DAMPING VALUE 247 2.0 s</p> <p style="text-align: right;"><small>P01-xxxxxxx-19-xx-xx-en-027</small></p>	<ol style="list-style-type: none"> 1. Press "+" or "-" to get to the editing mode. 2. The first digit is highlighted in black.
 <p>DAMPING VALUE 247 3.0 s</p> <p style="text-align: right;"><small>P01-xxxxxxx-19-xx-xx-en-028</small></p>	<ol style="list-style-type: none"> 1. Use "+" to change "2" to "3". 2. Confirm "3" with "E". The cursor jumps to the next position (highlighted in black).
 <p>DAMPING VALUE 247 30.0 s</p> <p style="text-align: right;"><small>P01-xxxxxxx-19-xx-xx-en-029</small></p>	The decimal point is highlighted in black, i.e. you can now edit it.

Onsite display	Operation
 <p style="text-align: right; font-size: small;">P01-xxxxxxxx-19-xx-xx-en-030</p>	<ol style="list-style-type: none"> 1. Keep pressing "+" or "-" until "0" is displayed. 2. Confirm "0" with "E". The cursor jumps to the next position. ↓ is displayed and is highlighted in black. → See next graphic.
 <p style="text-align: right; font-size: small;">P01-xxxxxxxx-19-xx-xx-en-031</p>	<p>Use "E" to save the new value and exit the editing mode. → See next graphic.</p>
 <p style="text-align: right; font-size: small;">P01-xxxxxxxx-19-xx-xx-en-032</p>	<p>The new value for the damping is now 30.0 s.</p> <ul style="list-style-type: none"> - Jump to the next parameter with "E". - You can get back to the editing mode with "+" or "-".

6.4.4 Taking pressure applied at device as value

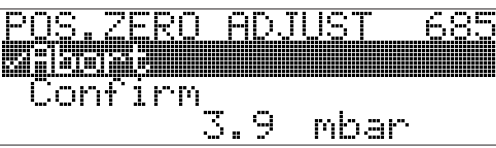
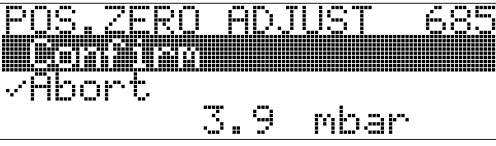
Example: performing position adjustment.

Onsite display	Operation
 <p style="text-align: right; font-size: small;">P01-xxxxxxxx-19-xx-xx-en-158</p>	<p>The bottom line on the onsite display shows the pressure present, here 3.9 mbar.</p>
 <p style="text-align: right; font-size: small;">P01-xxxxxxxx-19-xx-xx-en-159</p>	<p>Use "+" or "-" to switch to the "Confirm" option. The active selection is highlighted in black.</p>
 <p style="text-align: right; font-size: small;">P01-xxxxxxxx-19-xx-xx-en-037</p>	<p>Use "E" to assign the value (3.9 mbar) to the POS. ZERO ADJUST parameter. The device confirms the calibration and jumps back to the parameter, here POS. ZERO ADJUST (see next graphic).</p>
 <p style="text-align: right; font-size: small;">P01-xxxxxxxx-19-xx-xx-en-160</p>	<p>Switch to the next parameter with "E".</p>

6.5 FieldCare

FieldCare is an Endress+Hauser asset management tool based on FDT technology. With FieldCare, you can configure all Endress+Hauser devices as well as devices from other manufacturers that support the FDT standard. You can find hardware and software requirements on the Internet: www.endress.com → Search: FieldCare → FieldCare → Technical data

FieldCare supports the following functions:

- Configuration of transmitters in offline and online mode
- Loading and saving of device data (upload/download)
- HistoROM[®]/M-DAT analysis
- Documenting the measuring point

Connection options:

- Service interface with Commubox FXA291 and ToF adapter FXA291 (USB).
- In the "Level Standard" measuring mode, the configuration data that were loaded via FDT upload cannot be written again (FDT download). These data are only used to document the measuring point.
- For further information, see → www.endress.com

6.6 HistoROM[®]/M-DAT (optional)

NOTICE

Device could be destroyed!

Detach the HistoROM[®]/M-DAT module from the electronic insert or attach it to the insert in a de-energized state only.

HistoROM[®]/M-DAT is a memory module, which is attached to the electronic insert and fulfils the following functions:

- Back-up copy of configuration data
- Copying configuration data from one transmitter to another transmitter
- Cyclic recording of pressure and sensor temperature measured values
- Recording of diverse events, such as alarms, configuration changes, counters to record when the measuring range is undershot or exceeded for pressure and temperature, or when the user limits for pressure and temperature are exceeded or undershot etc.
- The HistoROM[®]/M-DAT can be retrofitted at any stage (order number: 52027785).
- To analyze and evaluate the data and events saved in the HistoROM[®]/M-DAT module, you require the Endress+Hauser FieldCare operating program. A CD with the operating program and documentation is provided for devices that were ordered with the "HistoROM[®]/M-DAT" option. See also → [40](#), section 6.5 "FieldCare". It is also possible to copy configuration data from one transmitter to another transmitter with an FF configuration program.
- The HistoROM data and the data in the device are analyzed once a HistoROM[®]/M-DAT module is attached to the electronic insert and power is re-established to the device. During the analysis, the messages "W702, HistoROM data not consistent" and "W706, Configuration in HistoROM and device not identical" can occur. For remedial measures, see → [71](#), section 9.2 "Diagnostic information on onsite display".

6.6.1 Copying configuration data

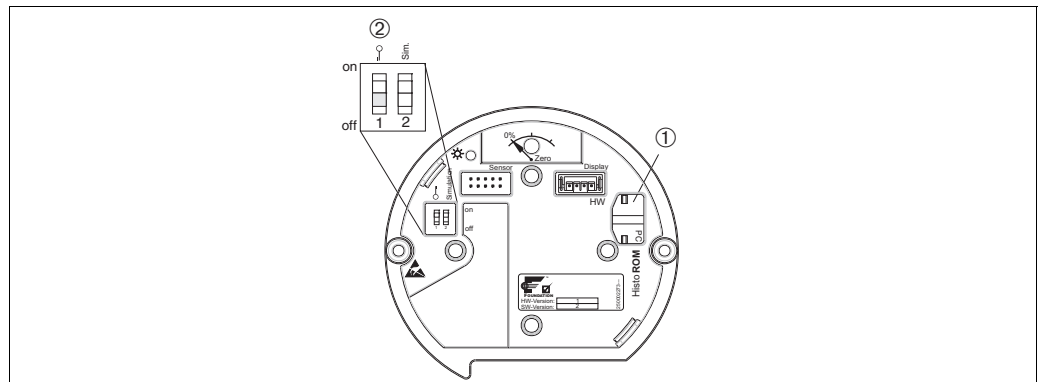

Electronic insert with optional HistoROM®/M-DAT memory module

- 1 Optional HistoROM®/M-DAT
- 2 To copy configuration data from the HistoROM®/M-DAT to a device or from a device to a HistoROM®/M-DAT module, operation must be unlocked (DIP switch 1, position "Off", parameter SWLOCK /INSERT PIN No = 100). Please refer also to → 43, section 6.7 "Locking/unlocking operation".

Onsite operation via onsite display (optional) or remote operation

Copying configuration data from a device to a HistoROM®/M-DAT module:

Operation must be unlocked.

1. Disconnect the device from the supply voltage.
2. Remove protective cap, attach the HistoROM®/M-DAT module to the electronic insert.
3. Re-establish the supply voltage to the device.
4. The DOWNLOAD SELECT. parameter (OPERATION menu) setting has no influence on an upload from the device into HistoROM.
5. Operation via an FF configuration program: using the DAT_HANDLING/ HistoROM CONTROL parameter in the Service Transducer Block, select the "Device → HistoROM" option for the data transfer direction.
Operation via FieldCare: using the HistoROM CONTROL parameter, select the "Device → HistoROM" option for the data transfer direction. (Menu path: OPERATING MENU → OPERATION)
Use the DOWNLOAD SELECT parameter (OPERATION menu) to select which parameters are to be overwritten.
The following parameters are overwritten according to the selection:
 - **Configuration copy:**
All the parameters apart from the TRANSMITTER SERIAL NO., DEVICE DESIGNATION and the parameters of the POSITION ADJUSTMENT and PROCESS CONNECTION group
 - **Device replacement:**
All the parameters apart from the TRANSMITTER SERIAL NO., DEVICE DESIGNATION and the parameters of the POSITION ADJUSTMENT and PROCESS CONNECTION group
 - **Electronics replace:**
All parameters apart from the parameters of the POSITION ADJUSTMENT group
Factory setting: Configuration copy
6. Using the HistoROM CONTROL parameter, select the "Device → HistoROM" option as the data transfer direction.
7. Wait approx. 40 seconds. Configuration data are loaded from the device to the HistoROM®/M-DAT module. The device is not restarted.
8. Disconnect device from the supply voltage again.
9. Detach memory module.
10. Re-establish the supply voltage to the device.

Copying configuration data from a HistoROM®/M-DAT to a device:

Operation must be unlocked.

1. Disconnect the device from the supply voltage.
2. Attach the HistoROM®/M-DAT module to the electronic insert. Configuration data from another device are stored in the HistoROM®/M-DAT.
3. Re-establish the supply voltage to the device.
4. Operation via an FF configuration program: using the DAT_HANDLING/ HistoROM CONTROL parameter in the Service Transducer Block, select the "HistoROM → Device" option for the data transfer direction.
 Operation via FieldCare: using the HistoROM CONTROL parameter, select the "HistoROM → Device" option for the data transfer direction (menu path: OPERATING MENU → OPERATION).
 Use the DOWNLOAD SELECT parameter (OPERATION menu) to select which parameters are to be overwritten.
 The following parameters are overwritten according to the selection:
 - **Configuration copy (factory setting)**
 all parameters except DEVICE SERIAL No., DEVICE DESIGN, PD-TAG, DESCRIPTION, DEVICE ID, DEVICE ADDRESS and the parameters in the POSITION ADJUSTMENT, PROCESS CONNECTION, SENSOR TRIM and SENSOR DATA group.
 - **Device replacement**
 all parameters except DEVICE SERIAL No., DEVICE ID, DEVICE DESIGN and the parameters in the POSITION ADJUSTMENT, PROCESS CONNECTION, SENSOR TRIM and SENSOR DATA group.
 - **Electronics replacement**
 all parameters except the parameters in the SENSOR DATA group.
 Factory setting: Configuration copy
5. Operation via an FF configuration program: using the DAT_HANDLING/ HistoROM CONTROL parameter in the Service Transducer Block, select the "HistoROM → Device" option for the data transfer direction.
 Operation via FieldCare: using the HistoROM CONTROL parameter, select the "HistoROM → Device" option for the data transfer direction. (Menu path: OPERATING MENU → OPERATION)
6. Using the HistoROM CONTROL parameter (OPERATION menu), select the "HistoROM → Device" option as the data transfer direction.
7. Wait approx. 40 seconds. Configuration data are loaded from the HistoROM®/M-DAT to the device. The device is restarted.
8. Before removing the HistoROM®/M-DAT again from the electronic insert, disconnect the device from the supply voltage.

6.7 Locking/unlocking operation

Once you have entered all the parameters, you can lock your entries against unauthorized and undesired access.

You have the following possibilities for locking/unlocking operation:

- Via the DIP switch on the electronic insert, locally at the device.
- Via communication, e.g. FieldCare

The  symbol on the onsite display indicates that operation is locked. Parameters which refer to how the display appears, e.g. LANGUAGE and DISPLAY CONTRAST, can still be altered.

- If operation is locked by means of the DIP switch, you can only unlock it again using the DIP switch. If operation is locked via remote operation, e.g. FieldCare, you can only unlock it again via remote operation.

The table provides an overview of the locking functions:

Locking via	View/read parameters	Modify/write via ¹⁾		Unlock via		
		Onsite display	Remote operation	DIP switch	Onsite display	Remote operation
DIP switch	Yes	No	No	Yes	No	No
Onsite display	Yes	No	No	No	Yes	Yes
Communication	Yes	No	No	No	Yes	Yes

1) Parameters which refer to how the display appears, e.g. LANGUAGE and DISPLAY CONTRAST, can still be altered.

6.7.1 Locking/unlocking operation locally via DIP switch

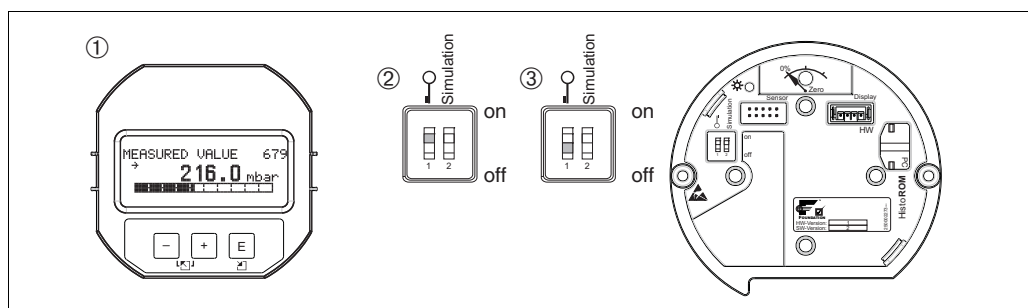

P01-xxxxxxx-19-xx-xx-xx-177

Fig. 12: "Hardware locking" DIP switch position on the electronic insert

- 1 If necessary, remove the (optional) onsite display
- 2 DIP switch is at "On": operation is locked.
- 3 DIP switch is at "Off": operation is unlocked (operation possible)

6.7.2 Locking/unlocking operation via remote operation

	Description
Locking operation	<ol style="list-style-type: none"> 1. Operation via FF configuration program: select SWLOCK parameter in the Resource Block Operation via FieldCare: select INSERT PIN No parameter Menu path: OPERATING MENU → OPERATION → INSERT PIN No 2. To lock operation, enter "0" for the parameter.
Unlocking operation	<ol style="list-style-type: none"> 1. Operation via FF configuration program: select SWLOCK parameter in the Resource Block. Operation via FieldCare: select INSERT PIN No parameter. 2. To unlock operation, enter "100" for the parameter.

6.8 Simulation

The function of the Analog Input Block, such as input and output scaling, can be simulated as follows:

1. Set the "Simulation" DIP switch on the electronic insert to "On".
2. In the Analog Input Block, select the "Active" option by means of the SIMULATION parameter, ENABLE_DISABLE element.
3. Set the Analog Input Block to the AUTO block mode.
4. Enter the value and status for the SIMULATION_VALUE and SIMULATION_STATUS elements. During the simulation, the output value and status of the Pressure Transducer Block are replaced by the simulated value and status. The OUT parameter shows the result.
5. End simulation (SIMULATION parameter, ENABLE_DISABLE element, "Disabled" option).

You can check your adjustment for the transmitter by means of the SIMULATION_MODE and SIMULATION_VALUE parameters in the Diagnostic Transducer Block. → See Operating Instructions BA303 "Description of Device Functions Cerabar S/Deltabar S, Deltapilot S", parameter descriptions SIMULATION_MODE and SIMULATION_VALUE.

6.9 Factory setting (reset)

- Total reset: Press zero-key for at least 12 seconds. The LED on the electronic insert lights up briefly if a reset is being carried out.
- By entering a certain code, you can completely, or partially, reset the entries for the parameters to the factory settings. (→ For factory settings, refer to the Operating Instructions BA00303P "Cerabar S/Deltabar S/Deltapilot S, Description of device functions".)
Enter the code by means of the ENTER RESET CODE parameter (OPERATION menu). There are various reset codes for the device. The following table illustrates which parameters are reset by the particular reset codes. Operation must be unlocked to reset parameters (see → 43, "section 6.7").
- Any customer-specific configuration carried out at the factory is not affected by a reset (customer-specific configuration remains). If, after a reset, you wish the parameters to be reset to the factory settings, please contact Endress+Hauser Service.
- The OUT Value may have to be rescaled after resetting with code 7864.
See also → 58, section 7.8 "Scaling OUT parameter".

6.9.1 Performing reset via an FF configuration program

If operating via an FF configuration program, enter the code by means of the RESET_INPUT_VALUE/ENTER RESET CODE parameter in the Diagnostic Transducer Block. The index tables → 32 ff. indicate which parameters are reset by the particular reset code. The RESET_FF parameter gives you the option of deleting links between function blocks and resetting FF parameters to default values and manufacturer-specific parameters to the factory setting. → See also Operating Instructions BA00303P, RESTART parameter description.

6.9.2 Performing reset via the FieldCare operating program

If operating via FieldCare, enter the code via the ENTER RESET CODE parameter (menu path: OPERATING MENU → OPERATION).

The following table illustrates which parameters are reset by the particular reset codes.

Reset code	Description and effect ¹⁾
7864	<p>Total reset</p> <ul style="list-style-type: none"> - This reset resets the following parameters: <ul style="list-style-type: none"> - POSITION ADJUSTMENT function group - BASIC SETUP function group - EXTENDED SETUP function group - LINEARIZATION function group (an existing linearization table is deleted) - OUTPUT group - INFO function group, TAG_DESC parameter - MESSAGES function group - All configurable messages ("Error" type) are set to "Warning". See also → 71, section 9.2 "Diagnostic information on onsite display" and → 85, section 9.6 "Response of outputs to errors". - USER LIMITS function group - Any simulation running is terminated. - The device is restarted.
333	<p>User reset</p> <ul style="list-style-type: none"> - This reset resets the following parameters: <ul style="list-style-type: none"> - POSITION ADJUSTMENT function group - BASIC SETUP function group, apart from customer-specific units - EXTENDED SETUP function group - OUTPUT group - Any simulation running is terminated. - The device is restarted.
2710	<p>Measuring mode level reset</p> <ul style="list-style-type: none"> - Depending on the settings for the LEVEL MODE, LIN MEASURAND, LIND MEASURAND or COMB. MEASURAND parameters, the parameters needed for this measuring task will be reset. - Any simulation running is terminated. - The device is restarted. <p>Example LEVEL MODE = linear and LIN. MEASURAND = level</p> <ul style="list-style-type: none"> ■ HEIGHT UNIT = m ■ CALIBRATION MODE = wet ■ EMPTY CALIB. = 0 ■ FULL CALIB. = Sensor end value converted to mH₂O, e.g. 50.99 mH₂O for a 500 mbar (7.5 psi) sensor
2509	<p>Sensor calibration reset</p> <ul style="list-style-type: none"> - This reset resets the upper and lower sensor calibration limit and the value for position adjustment. <ul style="list-style-type: none"> - POSITION ADJUSTMENT function group - PRESSURE_1_LOWER_CAL/LO_TRIM_MEASURED and PRESSURE_1_HIGHER_TRIM_MEASURED/HI_TRIM_MEASURED parameters These parameters are not available by means of the FieldCare operating program. - Any simulation running is terminated. - The device is restarted.
1846	<p>Display reset</p> <ul style="list-style-type: none"> - This reset resets all parameters related to how the display appears (DISPLAY group). - Any simulation running is terminated. - The device is restarted.
8888	<p>HistoROM reset</p> <p>The measured value and event buffers are deleted. During the reset, the HistoROM has to be attached to the electronic insert.</p>

Reset code	Description and effect ¹⁾
62	PowerUp reset (warm start) <ul style="list-style-type: none">- This reset resets all the parameters in the RAM. Data are read back anew from the EEPROM (processor is initialized again).- Any simulation running is terminated.- The device is restarted.

- 1) The table uses the group and parameter names as they appear in Field Care. See → [32](#), section 6.3.8 "Index tables of Endress+Hauser parameters" for the assignment of the FieldCare parameter names and the FF configuration program.

7 Commissioning

The device is configured for the "Level" measuring mode as standard. The measuring range and the unit in which the measured value is transmitted correspond to the data on the nameplate.

▲ WARNING

The permitted process pressure is exceeded!

Risk of injury due to bursting of parts! Warning messages are generated if pressure is too high.

- ▶ If a pressure that is greater than the maximum permitted pressure is present at the device, messages "E115 Sensor overpressure" and "E727 Sensor pressure error - overrange" are output in succession. Only use the device within the sensor range limits!

NOTICE

The permitted process pressure is undershot!

Output of messages if pressure is too low.

- ▶ If a pressure that is lower than the minimum permitted pressure is present at the device, messages "E120 Sensor low pressure" and "E727 Sensor pressure error - overrange" are output in succession. Only use the device within the sensor range limits!

7.1 Configuring messages

- Messages E727, E115 and E120 are "Error" messages and can be configured as a "Warning" or an "Alarm". These messages are configured as "Warning" messages at the factory. This setting prevents the current output from assuming the set alarm current value for applications (e.g. cascade measurement) where the user is consciously aware of the fact that the sensor range can be exceeded.
- We recommend setting messages E727, E115 and E120 to "Alarm" in the following instances:
 - It is not necessary to go outside the sensor range for the measuring application.
 - A position adjustment must be carried out that has to correct a large measurement error as a result of the orientation of the device (e.g. devices with a diaphragm seal).

7.2 Function check

Carry out a post-installation and a post-connection check as per the checklist before commissioning the device.

- "Post-installation check" checklist → see section 4.5
- "Post-connection check" checklist → see section 5.4

7.3 Commissioning via an FF configuration program

- The measuring range and the unit in which the measured value is transmitted, as well as the digital output value of the Analog Input Block OUT, correspond to the data on the nameplate. Following a reset with code 7864, the OUT parameter may have to be rescaled (see also → [§ 58](#), section 7.8 "Scaling OUT parameter").
 - The standard order configuration is illustrated on → [§ 27](#), section 6.3.6 "Deltapilot S block model".
1. Switch on the measuring instrument.
 2. Note the DEVICE_ID. See also → [§ 27](#), section 6.3.5 "Device identification and addressing" and "Nameplates" for the device serial number.
 3. Open the configuration program.
 4. Load Cff and device description files into the host system or the configuration program. Make sure you are using the right system files.

5. Identify the device using the `DEVICE_ID` (→ see Point 2). Assign the desired tag name to the device by means of the `PD_TAG` parameter.

Configuring the Resource Block

1. Open the Resource Block.
2. If necessary, disable the lock for device operation. See → [43](#), section 6.7 "Locking/unlocking operation". Operating is unlocked as standard.
3. If necessary, change the block name. Factory setting: `RS_452B481007-xxxxxxxxxxx`
4. If necessary, assign a description to the block by means of the `TAG_DESC` parameter.
5. If necessary, change other parameters as per the requirements.

Configuring the Transducer Blocks

The Deltapilot S has the following Transducer Blocks:

- Pressure Transducer Block
- Service Transducer Block
- Display Transducer Block
- Diagnostic Transducer Block

The explanation that follows is an example for the Pressure Transducer Block.

1. If necessary, change the block name. Factory setting: `RS_452B481007-xxxxxxxxxxx`
2. Set the block mode to OOS using the `MODE_BLK` parameter, TARGET element.
3. Configure the device in accordance with the measuring task. → See also these Operating Instructions section 7.4 to section 7.8.
4. Set the block mode to Auto using the `MODE_BLK` parameter, TARGET element.

The block mode must be set to "Auto" for the Pressure and Service Transducer Block for the measuring instrument to function correctly.

Configuring the Analog Input Blocks

The Deltapilot S has 2 Analog Input Blocks that can be assigned as required to the various process variables.

1. If necessary, change the block name. Factory setting: `RS_452B481007-xxxxxxxxxxx`
2. Set the block mode to OOS using the `MODE_BLK` parameter, TARGET element.
3. Use the `CHANNEL` parameter to select the process variable which should be used as the input value for the Analog Input Block. The following settings are possible:
 - `CHANNEL = 1`: Primary value, a pressure or level value depending on the measuring mode selected
 - `CHANNEL = 2`: Secondary value, here the sensor temperature
 Factory setting:
 - Analog Input Block 1: `CHANNEL = 1`: Primary Value (pressure measured value)
 - Analog Input Block 2: `CHANNEL = 2`: Secondary Value (sensor temperature)
4. Use the `XD_SCALE` parameter to select the desired unit and the block input range for the process variable. See also → [58](#), section 7.8 "Scaling OUT parameter". Make sure that the selected unit suits the process variable that is selected. If the process variable does not suit the unit, the `BLOCK_ERROR` parameter reports "Block Configuration Error" and the block mode cannot be set to "Auto".
5. Use the `L_TYPE` parameter to select the type of linearization for the input variable (factory setting: Direct). Make sure that the settings for the `XD_SCALE` and `OUT_SCALE` parameters are the same for the "Direct" linearization type. If the process values and units do not match, the `BLOCK_ERROR` parameter reports "Block Configuration Error" and the block mode cannot be set to "Auto".

6. Enter the alarm and critical alarm messages by means of the HI_HI_LIM, HI_LIM, LO_LIM and LO_LO_LIM parameters. The limit values entered have to be within the value range specified for the OUT_SCALE parameter.
7. Specify the alarm priorities by means of the HI_HI_PRI, HI_PRI, LO_LO_PRI and LO_PRI parameters. Reporting to the field host system only takes place with alarms with a priority greater than 2.
8. Set the block mode to Auto using the MODE_BLK parameter, TARGET element. For this purpose, the Resource Block must also be set to the "Auto" block mode.

Additional configuration

1. Depending on the control or automation task, configure additional function blocks and output blocks. → See also Operating Instructions BA00303P "Description of Device Functions Cerabar S/Deltabar S/Deltapilot S".
2. Link the function blocks and output blocks.
3. After specifying the active LAS, download all the data and parameters to the field device.

7.4 Selecting the language and measuring mode

7.4.1 Onsite operation

The MEASURING MODE parameter is on the first selection level. section 6.4.1 "Menu structure".

The following measuring modes are available:

- Pressure
- Level

7.4.2 Selecting the language and measuring mode by means of the FieldCare operating program

Selecting the measuring mode

▲ WARNING

Changing the measuring mode affects the span (URV)!

This situation can result in product overflow.

- ▶ If the measuring mode is changed, the span setting (URV) must be verified in the operating menu "SETTINGS → BASIC SETUP" and reconfigured if necessary!

The parameters for setting the measuring mode are displayed in the FieldCare "Measuring mode" menu:

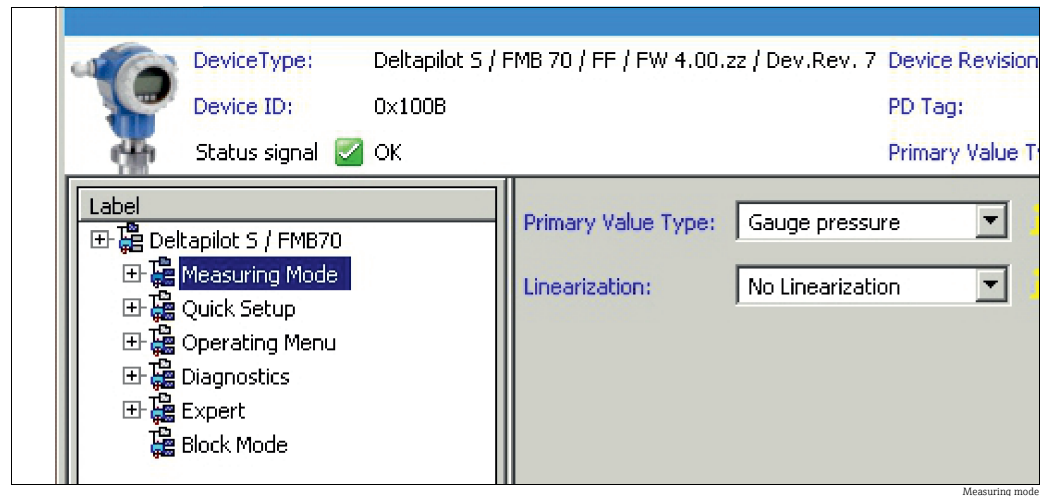

Fig. 13: "Measuring mode" menu

The following measuring mode settings are available:

Primary value type	Linearization	Level selection
Pressure	None	-
Level, mass, volume	None	Level Easy Pressure
Level, mass, volume	None	Level Easy Height
Level, mass, volume, tank content in %	None	Level Standard
Level, mass, volume, tank content in %	Level linearized	Level Standard
Level, mass, volume, tank content in %	Level combined	Level Standard

Selecting the language

Select the menu language for FieldCare using the "Language Button" in the configuration window. Select the menu language for the FieldCare frame using the "Extra" menu → "Options" "Display" → "Language".

The following languages are available:

- Deutsch
- English
- Français
- Español
- Chinese
- Japanese

7.5 Position adjustment

Due to the orientation of the device, there may be a shift in the measured value, i.e. when the vessel is empty or partly filled, the measured value does not display zero. There are two ways to perform position adjustment.

- Menu path onsite display:
GROUP SELECTION → OPERATING MENU → SETTINGS → POSITION ADJUST.
- Menu path FieldCare:
OPERATING MENU → SETTINGS P → POSITION ADJUST

7.5.1 Performing position adjustment via the local display or FieldCare

The parameters listed in the following table can be found in the POSITION ADJUST. group (menu path: OPERATING MENU → SETTINGS → POSITION ADJUST.).

Parameter name	Description
POS. ZERO ADJUST Entry	<p>Position adjustment – the pressure difference between zero (set point) and the measured pressure need not be known.</p> <p>Example:</p> <ul style="list-style-type: none"> – MEASURED VALUE = 2.2 mbar (0.032 psi) – Correct the MEASURED VALUE via the POS. ZERO ADJUST parameter using the "Confirm" option. This means that you are assigning the value 0.0 to the pressure present. – MEASURED VALUE (after pos. zero adjust) = 0.0 mbar <p>The CALIB. OFFSET parameter displays the resulting pressure difference (offset) by which the MEASURED VALUE was corrected.</p> <p>Factory setting: 0.0</p>
POS. INPUT VALUE Entry	<p>Position adjustment – the pressure difference between zero (set point) and the measured pressure need not be known. To correct the pressure difference, a reference measurement value (e.g. from a reference device) is required.</p> <p>Example:</p> <ul style="list-style-type: none"> – MEASURED VALUE = 0.5 mbar (0.0073 psi) – For the POS. INPUT VALUE parameter, specify the desired set point for the MEASURED VALUE, e.g. 2.0 mbar (0.029 psi). (The following applies: $\text{MEASURED VALUE}_{\text{new}} = \text{POS. INPUT VALUE}$) – MEASURED VALUE (after entry for POS. INPUT VALUE) = 2.0 mbar (0.029 psi) – The CALIB. OFFSET parameter displays the resulting pressure difference (offset) by which the MEASURED VALUE was corrected. The following applies: $\text{CALIB. OFFSET} = \text{MEASURED VALUE}_{\text{old}} - \text{POS. INPUT VALUE}$, here: $\text{CALIB. OFFSET} = 0.5 \text{ mbar (0.0073 psi)} - 2.0 \text{ mbar (0.029 psi)} = -1.5 \text{ mbar (0.022 psi)}$) <p>Factory setting: 0.0</p>
CALIB. OFFSET Entry	<p>Position adjustment - the pressure difference between zero (set point) and the measured pressure is known. (A reference pressure is not present at the device.)</p> <p>Example:</p> <ul style="list-style-type: none"> – MEASURED VALUE = 2.2 mbar (0.032 psi) – Using the CALIB. OFFSET parameter, enter the value by which the MEASURED VALUE should be corrected. To correct the MEASURED VALUE to 0.0 mbar, you must enter the value 2.2 here. (The following applies: $\text{MEASURED VALUE}_{\text{new}} = \text{MEASURED VALUE}_{\text{old}} - \text{CALIB. OFFSET}$) – MEASURED VALUE (after entry for calib. offset) = 0.0 mbar <p>Factory setting: 0.0</p>

7.6 Level measurement

7.6.1 Information on level measurement

- A Quick Setup menu is available for each of the measuring modes Pressure and Level which guides you through the most important basic functions. → See →  54 for the "Level" Quick Setup menu.
- Furthermore, the three level modes "Level Easy Pressure", "Level Easy Height" and "Level Standard" are available to you for level measurement. You can select from the "Linear", "Pressure linearized" and "Height linearized" level types for the "Level Standard" level mode. The table in the "Overview of level measurement" section below provides an overview of the various measuring tasks.
 - In the "Level Easy Pressure" and "Level Easy Height" level modes, the values entered are not tested as extensively as in the "Level Standard" level mode. The values entered for EMPTY CALIB./FULL CALIB., EMPTY PRESSURE/FULL PRESSURE and EMPTY HEIGHT/FULL must have a minimum interval of 1% for the "Level Easy Pressure" and "Level Easy Height" level modes. The value will be rejected, and a message displayed, if the values are too close together. Other limit values are not checked, i.e. the values entered must be appropriate for the sensor and the measuring task for the measuring instrument to be able to measure correctly.
 - The "Level Easy Pressure" and "Level Easy Height" level modes encompass fewer parameters than the "Level Standard" mode and are used for quick and easy configuration of a level application.
 - Customer-specific units of level, volume and mass or a linearization table may only be entered in the "Level Standard" level mode.
- For a detailed parameter description and examples of parameters, see the Operating Instructions BA00303P "Cerabar S/Deltabar S/Deltapilot S, Description of device functions".

WARNING

Changing the measuring mode affects the span (URV)!

This situation can result in product overflow.

- ▶ If the measuring mode is changed, the span setting (URV) must be verified in the operating menu "SETTINGS → BASIC SETUP" and reconfigured if necessary!

7.6.2 Overview of level measurement

Measuring task	LEVEL SELECTION/ LEVEL MODE	Measured variable options	Description	Note	Measured value display
The measured variable is in direct proportion to the measured pressure. Calibration is performed by entering two pressure-level value pairs.	LEVEL SELECTION: Level Easy Pressure	Via OUTPUT UNIT parameter: %, level, volume or mass units.	<ul style="list-style-type: none"> - Calibration with reference pressure – wet calibration, see Operating Instructions BA00303P. - Calibration without reference pressure – dry calibration, see Operating Instructions BA00303P. 	<ul style="list-style-type: none"> - Incorrect entries are possible - Customized units are not possible 	The measured value display and the LEVEL BEFORE LIN parameter show the measured value.
The measured variable is in direct proportion to the measured pressure. Calibration is performed by entering the density and two height-level value pairs.	LEVEL SELECTION: Level Easy Height	Via OUTPUT UNIT parameter: %, level, volume or mass units.	<ul style="list-style-type: none"> - Calibration with reference pressure – wet calibration, see Operating Instructions BA00303P. - Calibration without reference pressure – dry calibration, see Operating Instructions BA00303P. 	<ul style="list-style-type: none"> - Incorrect entries are possible - Customized units are not possible 	The measured value display and the LEVEL BEFORE LIN parameter show the measured value.
The measured variable is in direct proportion to the measured pressure.	LEVEL SELECTION: Level Standard/ LEVEL MODE: Linear	Via the LINEAR MEASURAND parameter: <ul style="list-style-type: none"> - % (level) - Level - Volume - Mass 	<ul style="list-style-type: none"> - Calibration with reference pressure – wet calibration, see Operating Instructions BA00303P. - Calibration without reference pressure – dry calibration, see Operating Instructions BA00303P. 	<ul style="list-style-type: none"> - Incorrect entries are rejected by the device - Customized level, volume and mass units are possible 	The measured value display and the LEVEL BEFORE LIN parameter show the measured value.
The measured variable is not in direct proportion to the measured pressure as, for example, with vessels with a conical outlet. A linearization table must be entered for the calibration.	LEVEL SELECTION: Level standard/ LEVEL MODE: Pressure linearized	Via LINd MEASURAND parameter: <ul style="list-style-type: none"> - Pressure + % - Pressure + volume - Pressure + mass 	<ul style="list-style-type: none"> - Calibration with reference pressure: semi-automatic entry of linearization table, see Operating Instructions BA00303P. - Calibration without reference pressure: manual entry of linearization table, see Operating Instructions BA00303P. 	<ul style="list-style-type: none"> - Incorrect entries are rejected by the device - Customized level, volume and mass units are possible 	The measured value display and the TANK CONTENT parameter show the measured value.
<ul style="list-style-type: none"> - Two measured variables are required or - The vessel shape is given by value pairs, such as height and volume. <p>The 1st measured variable %-height or height must be in direct proportion to the measured pressure. The 2nd measured variable volume, mass or % must not be in direct proportion to the measured pressure. A linearization table must be entered for the 2nd measured variable. The 2nd measured variable is assigned to the 1st measured variable by means of this table.</p>	LEVEL SELECTION: Level Standard/ LEVEL MODE: Height linearized	Via COMB. MEASURAND parameter: <ul style="list-style-type: none"> - Height + volume - Height + mass - Height + % - %-height + volume - %-height + mass - %-height + % 	<ul style="list-style-type: none"> - Calibration with reference pressure: wet calibration and semiautomatic entry of linearization table, see Operating Instructions BA00303P. - Calibration without reference pressure: dry calibration and manual entry of linearization table, see Operating Instructions BA00303P. 	<ul style="list-style-type: none"> - Incorrect entries are rejected by the device - Customized level, volume and mass units are possible 	<p>The measured value display and the TANK CONTENT parameter display the 2nd measured value (volume, mass or %).</p> <p>The LEVEL BEFORE LIN parameter displays the 1st measured value (%-height or height).</p>

7.6.3 Quick Setup menu for the Level measuring mode

- Some parameters are only displayed if other parameters are appropriately configured. For example, the EMPTY CALIB. parameter is only displayed in the following cases:
 - LEVEL SELECTION "Level Easy Pressure" and CALIBRATION MODE "Wet"
 - LEVEL SELECTION "Level Standard", LEVEL MODE "Linear" and CALIBRATION MODE "WET"
 You can find the LEVEL MODE and CALIBRATION MODE parameters in the BASIC SETUP function group.
- The following parameters are set to the following values in the factory:
 - LEVEL SELECTION: Level Easy Pressure
 - CALIBRATION MODE: Wet
 - OUTPUT UNIT or LIN. MEASURAND: %
 - EMPTY CALIB.: 0.0
 - FULL CALIB.: 100.0
- The quick setup is suitable for simple and quick commissioning. If you wish to make more complex settings, e.g. change the unit from "%" to "m", you will have to calibrate using the BASIC SETUP group. → See Operating Instructions BA00303P.

⚠ WARNING

Changing the measuring mode affects the span (URV)!

This situation can result in product overflow.

- ▶ If the measuring mode is changed, the span setting (URV) must be verified in the operating menu "SETTINGS → BASIC SETUP" and reconfigured if necessary!

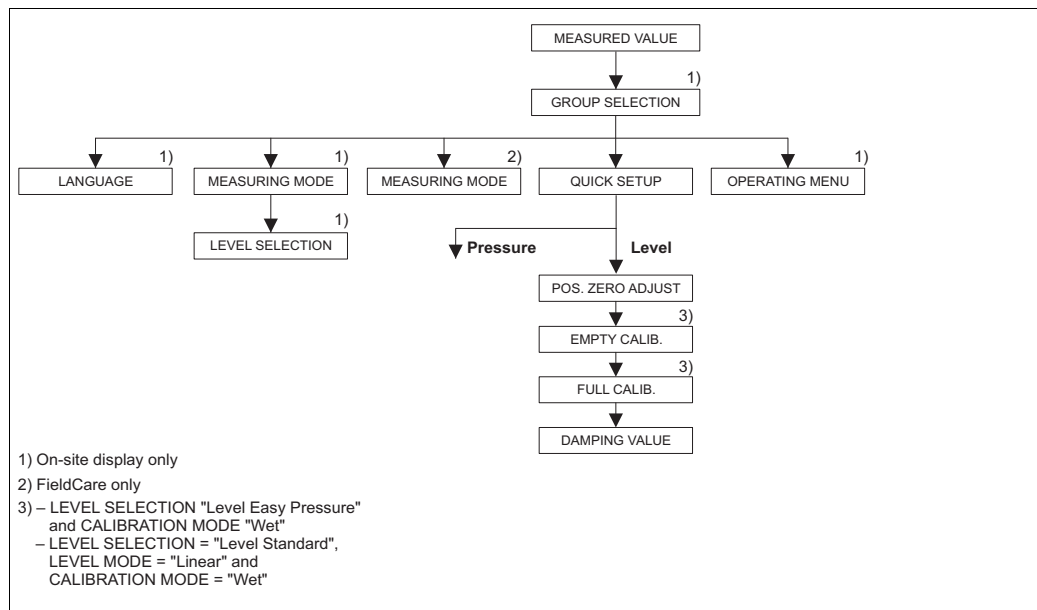



Fig. 14: Quick Setup menu for the "Level" measuring mode

Onsite operation	FieldCare
Measured value display Switch from the measured value display to GROUP SELECTION with F.	Measured value display Select the QUICK SETUP menu.
GROUP SELECTION Select the MEASURING MODE.	Measuring Mode Select the Primary Value Type parameter.
MEASURING MODE Select "Level" option.	Primary value type Select "Level" option.
LEVEL SELECTION Select level mode. For an overview, see → 53.	LEVEL SELECTION / Level Selection Select level mode. For an overview, see → 53
GROUP SELECTION Select the QUICK SETUP menu.	

Onsite operation	FieldCare
<p>POS. ZERO ADJUST Due to the orientation of the device, there may be a shift in the measured value. You correct the MEASURED VALUE via the POS. ZERO ADJUST parameter using the "Confirm" option, i.e. you assign the value 0.0 to the pressure present.</p>	<p>POS. ZERO ADJUST Due to the orientation of the device, there may be a shift in the measured value. You correct the MEASURED VALUE via the POS. ZERO ADJUST parameter using the "Confirm" option, i.e. you assign the value 0.0 to the pressure present.</p>
<p>EMPTY CALIB. ¹⁾ Enter level value for the lower calibration point. For this parameter, enter a level value which is assigned to the pressure present at the device.</p>	<p>EMPTY CALIB. ¹⁾ Enter level value for the lower calibration point. For this parameter, enter a level value which is assigned to the pressure present at the device.</p>
<p>FULL CALIB. ¹⁾ Enter level value for the upper calibration point. For this parameter, enter a level value which is assigned to the pressure present at the device.</p>	<p>FULL CALIB. ¹⁾ Enter level value for the upper calibration point. For this parameter, enter a level value which is assigned to the pressure present at the device.</p>
<p>DAMPING VALUE Enter damping time (time constant τ). The damping affects the speed at which all subsequent elements, such as the onsite display, measured value and OUT value of the Analog Input Block react to a change in the pressure.</p>	<p>DAMPING VALUE Enter damping time (time constant τ). The damping affects the speed at which all subsequent elements, such as the onsite display, measured value and OUT value of the Analog Input Block react to a change in the pressure.</p>

- 1) - LEVEL SELECTION "Level Easy Pressure" and CALIBRATION MODE "Wet"
 - LEVEL SELECTION "Level Standard", LEVEL MODE "Linear" and CALIBRATION MODE "Wet"

For onsite operation, see also

-  24, section 6.2.3 "Function of operating elements – onsite display connected" and
→  37, section 6.4 "Onsite operation – onsite display connected".

7.7 Pressure measurement

7.7.1 Information regarding pressure measurement

- A Quick Setup menu is available for both the "Pressure" and "Level" measuring modes and guides you through the most important basic functions. You specify which Quick Setup menu should be displayed with the setting in the MEASURING MODE parameter. See also section 7.4 "Selecting the language and measuring mode".
- For a detailed parameter description, see the Operating Instructions BA00303P "Cerabar S/Deltabar S/Deltapilot S, Description of device functions"
 - FF: Table, Pressure Transducer Block
 - – FieldCare: Table, POSITION ADJUST.
 - – FieldCare: Table, BASIC SETUP
 - – FieldCare: Table, EXTENDED SETUP

⚠ WARNING

Changing the measuring mode affects the span (URV)!

This situation can result in product overflow.

- ▶ If the measuring mode is changed, the span setting (URV) must be verified in the operating menu "SETTINGS → BASIC SETUP" and reconfigured if necessary!

7.7.2 Quick Setup menu for the "Pressure" measuring mode

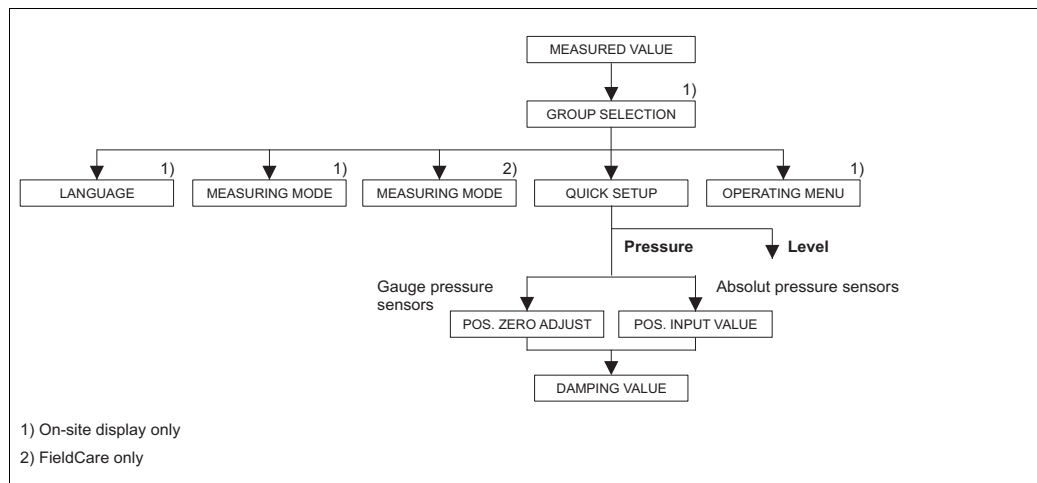



Fig. 15: Quick Setup menu for the "Pressure" measuring mode

Onsite operation	FieldCare
Measured value display Switch from the measured value display to GROUP SELECTION with F.	Measured value display Select the QUICK SETUP menu.
GROUP SELECTION Select the MEASURING MODE parameter.	Measuring Mode Select the Primary Value Type parameter.
MEASURING MODE Select "Pressure" option.	
GROUP SELECTION Select the QUICK SETUP menu.	Primary value type Select "Pressure" option.
POS. ZERO ADJUST Due to the orientation of the device, there may be a shift in the measured value. You correct the MEASURED VALUE via the POS. ZERO ADJUST parameter using the "Confirm" option, i.e. you assign the value 0.0 to the pressure present.	POS. ZERO ADJUST Due to the orientation of the device, there may be a shift in the measured value. You correct the MEASURED VALUE via the POS. ZERO ADJUST parameter using the "Confirm" option, i.e. you assign the value 0.0 to the pressure present.

Onsite operation	FieldCare
<p>POS. INPUT VALUE Due to the orientation of the device, there may be a shift in the measured value. Specify the desired set point for the MEASURED VALUE via the POS. INPUT VALUE parameter.</p>	<p>POS. INPUT VALUE Due to the orientation of the device, there may be a shift in the measured value. Specify the desired set point for the MEASURED VALUE via the POS. INPUT VALUE parameter.</p>
<p>DAMPING VALUE Enter damping time (time constant τ). The damping affects the speed at which all subsequent elements, such as the onsite display, measured value and OUT value of the Analog Input Block react to a change in the pressure.</p>	<p>DAMPING VALUE Enter damping time (time constant τ). The damping affects the speed at which all subsequent elements, such as the onsite display, measured value and OUT value of the Analog Input Block react to a change in the pressure.</p>

For onsite operation, see also

-  24, section 6.2.3 "Function of operating elements – onsite display connected" and
-  37, section 6.4 "Onsite operation – onsite display connected".

7.8 Scaling OUT parameter

In the Analog Input Block, the input value or input range can be scaled in accordance with the automation requirements.

Example:

The measuring range 0 to 500 mbar (0 to 7.5 psi) should be rescaled to 0 to 100 %.

- Select XD_SCALE group.
 - For EU_0, enter "0".
 - For EU_100, enter "500".
 - For UNITS_INDEX, enter "mbar".
- Select OUT_SCALE group.
 - For EU_0, enter "0".
 - For EU_100, enter "10000".
 - For UNITS_INDEX, select "%" for example.

The unit selected here does not have any effect on the scaling. This unit is not displayed on the onsite display or in the operating program such as FieldCare.

Result:

At a pressure of 350 mbar (5.25 psi), the value 70 is output to a downstream block or to the process control system as the OUT value.

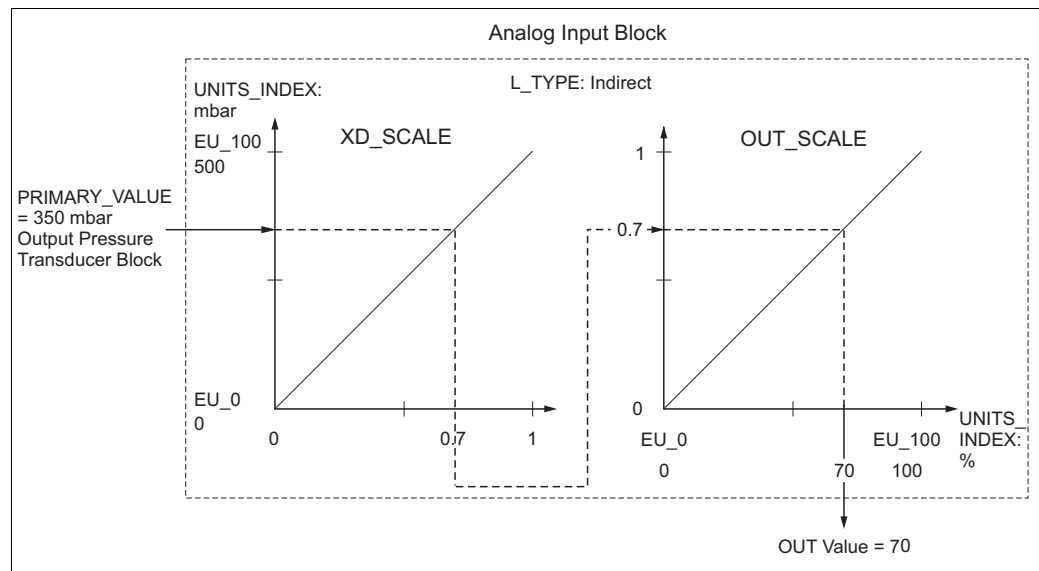

P01-xMx7xxxx-05-xx-xx-en-008

⚠ CAUTION

Note Dependencies when setting parameters!

- ▶ If you have selected the "Direct" mode for the L_TYPE parameter, you cannot change the values and units for XD_SCALE and OUT_SCALE.
- ▶ The L_TYPE, XD_SCALE and OUT_SCALE parameters can only be changed in the OOS block mode.
- ▶ Make sure that the output scaling of the Pressure Transducer Block SCALE_OUT matches the input scaling of the Analog Input Block XD_SCALE.

7.9 Configuring diagnostic behavior in accordance with FOUNDATION Fieldbus Specification FF912 Field Diagnostic Profile

The device complies with FOUNDATION Fieldbus specification FF912. Among other things this means that:

- The diagnostic category as per NAMUR Recommendation NE 107 is transmitted over the fieldbus in a format that is independent of the manufacturer:
 - F: Failure
 - C: Function check
 - S: Out of specification
 - M: Maintenance required
- The diagnostic category of the predefined event groups can be adapted by the user according to the requirements of the individual application.
- Certain events can be separated from their group and be treated individually:
 - e.g. 115: Sensor overpressure
 - e.g. 715: Sensor over temperature
- Additional information and troubleshooting measures are transmitted over the fieldbus with the event message.

7.9.1 Event groups

The diagnostic events are divided into 16 groups according to the source and the severity. A default event category is assigned to each group at the factory. Here, one bit of the assignment parameters belongs to every event group.

Event severity	Default event category	Event source	Bit	Events in this group
Highest severity	Failure (F)	Sensor	31	<ul style="list-style-type: none"> ■ 101: C>Sensor electronic EEPROM error ■ 122: F>Sensor not connected ■ 716: F>Process membrane broken ■ 725: C>Sensor connection error, cycle disturbance ■ 747: C>Sensor software not compatible to electronics
		Electronics module	30	<ul style="list-style-type: none"> ■ 110: F>Checksum error in EEPROM: configuration segment ■ 113: F>ROM failure in transmitter electronic ■ 121: F>Checksum error in factory segment of EEPROM ■ 130: F>EEPROM is defect. ■ 131: F>Checksum error in EEPROM: min/max segment ■ 132: F>Checksum error in totalizer EEPROM ■ 133: F>Checksum error in History EEPROM ■ 135: F>Checksum error in EEPROM FF segment ■ 703: C>Measurement error ■ 705: C>Measurement error ■ 728: F>RAM error ■ 729: F>RAM error ■ 736: F>RAM error ■ 737: C>Measurement error ■ 738: C>Measurement error ■ 739: C>Measurement error ■ 742: C>Sensor connection error (upload) ■ 743: C>Electronic PCB error during initialization ■ 744: C>Main electronic PCB error ■ 748: C>Memory failure in signal processor
		Configuration	29	<ul style="list-style-type: none"> ■ Not used
		Process	28	<ul style="list-style-type: none"> ■ Not used

Event severity	Default event category	Event source	Bit	Events in this group
High severity	Function check (C)	Sensor	27	<ul style="list-style-type: none"> Not used
		Electronics	26	<ul style="list-style-type: none"> 704: C>Measurement error 746: C>Sensor connection error - initializing
		Configuration	25	<ul style="list-style-type: none"> 106: C>Downloading - please wait 602: M>Linearization curve not monotone 604: M>Linearization table invalid. Min. 2 points. 613: C>Simulation active 701: S>Adjustment outside sensor nominal range 710: S>Set span too small. Not allowed 707: M>X-VAL. (TAB_XY_VALUE) of lin. table out of edit limits 711: M>LRV or URV out of edit limits 713: M>100% POINT (LEVEL_100_PERCENT_VALUE) level out of edit limits 719: M>Y-VALUE (TAB_XY_VALUE) of lin. table out of edit limits 721: M>ZERO POSITION (LEVEL_OFFSET) level out of edit limits 722: M>EMPTY CALIB. (SCALE_OUT, EU_0) or FULL CALIB. (SCALE_OUT, EU_100) out of edit limits 723: M>Max. flow (SCALE_OUT, EU_100) out of edit limits 741: M>TANK HEIGHT (LEVEL_TANK_HEIGHT) out of edit limits 750: M>Configuration not permitted
		Process	24	<ul style="list-style-type: none"> Not used

Event severity	Default event category	Event source	Bit	Events in this group
Low severity	Out of specification (S)	Sensor	23	<ul style="list-style-type: none"> 115: S>Sensor overpressure 120: S>Sensor low pressure 715: S>Sensor over temperature 720: S>Sensor under temperature 726: S>Sensor temperature error - overrange
		Electronics	22	<ul style="list-style-type: none"> 717: S>Transmitter over temperature 718: S>Transmitter under temperature
		Configuration	21	<ul style="list-style-type: none"> 727: S>Sensor pressure error - overrange
		Process	20	<ul style="list-style-type: none"> 730: M>Pmin ALARM WINDOW (PRESSURE_1_USER_LOW_LIMIT) undershot 731: M>Pmax ALARM WINDOW (PRESSURE_1_USER_HIGH_LIMIT) overshoot 732: M>Tmin ALARM WINDOW (TEMPERATURE_1_USER_LOW_LIMIT) undershot 733: M>Tmax ALARM WINDOW (TEMPERATURE_1_USER_HIGH_LIMIT) overshoot

Event severity	Default event category	Event source	Bit	Events in this group
Lowest severity	Maintenance required (M)	Sensor	19	<ul style="list-style-type: none"> 745: M>Sensor data unknown
		Electronics	18	<ul style="list-style-type: none"> 102: M>Checksum error in EEPROM: peakhold segment 134: M>EEPROM lifetime WARNING 700: M>Last configuration not stored 702: M>HistoROM data not consistent
		Configuration	17	<ul style="list-style-type: none"> 116: M>Download error, repeat download 706: M>Configuration in HistoROM and device not identical.
		Process	16	<ul style="list-style-type: none"> 740: S>Calculation overflow, bad configuration

7.9.2 Assignment parameters

Event categories are assigned to the event groups via four assignment parameters. These parameters are located in the **RESOURCE (RB2)** Block:

- **FD_FAIL_MAP**: for event category **Failure (F)**
- **FD_CHECK_MAP**: for event category **Function check (C)**
- **FD_OFFSPEC_MAP**: for event category **Out of specification (S)**
- **FD_MAINT_MAP**: for event category **Maintenance required (M)**

Each of these parameters consists of 32 bits with the following meaning:

- **Bit 0**: reserved by the Fieldbus Foundation. Is also set if 1 TRD is not in the AUTO mode.
- **Bits 1 to 15**: configurable area; certain diagnostic events can be assigned here irrespective of the event group they are in. They are not excluded from the event group and their behavior can be configured individually (→ 63). In the case of Deltabar S, the following events can be assigned to the configurable area:
 - e.g. 115: Sensor overpressure
 - e.g. 715: Sensor over temperature
- **Bits 16 to 31**: standard area; these bits are permanently assigned to the event groups. If the bit is set to **1**, this event group is assigned to the individual event category.

The following table indicates the default setting of the assignment parameters. In the factory setting, there is a clear assignment between the event severity and the event category (e.g. the assignment parameter).

Default setting of assignment parameters

Event severity	Standard area																Configurable area
	Highest severity				High severity				Low severity				Lowest severity				
Event source ¹⁾	S	E	K	P	S	E	K	P	S	E	K	P	S	E	K	P	
Bit	31	30	29	28	27	26	25	24	23	22	21	20	19	18	17	16	15 - 1
FD_FAIL_MAP	1	1	1	1	0	0	0	0	0	0	0	0	0	0	0	0	0
FD_CHECK_MAP	0	0	0	0	1	1	1	1	0	0	0	0	0	0	0	0	0
FD_OFFSPEC_MAP	0	0	0	0	0	0	0	0	1	1	1	1	0	0	0	0	0
FD_MAINT_MAP	0	0	0	0	0	0	0	0	0	0	0	0	1	1	1	1	0

1) S: Sensor; E: Electronics; C: Configuration; P: Process

Proceed as follows to change the diagnostic behavior of an event group:

1. Open the assignment parameter in which the group is currently assigned.
2. Change the event group bit from **1** to **0**. If using FieldCare, this is done via the FF912 module by disabling the appropriate check box (see the following example).
3. Open the assignment parameter to which the group should be assigned.
4. Change the event group bit from **0** to **1**. When operating via FieldCare, this is done by checking the corresponding check box (see the next example).

Example

The **Highest Severity / Electronics** group contains the events **131: Checksum error in EEPROM: min/max segment, among others**. These should no longer be categorized as **Failure (F)**, and should be categorized as **Function check (C)** instead.

1. In the FieldCare navigation window, go to **Expert** → **Field Device Diagnostic** → **Configuration**.

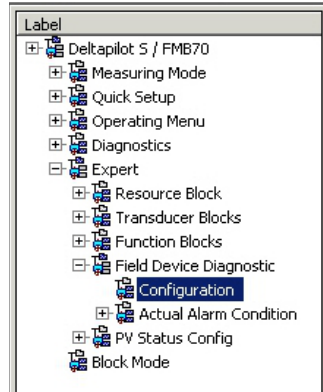

2. In the **Failure** column search for the **Highest Severity Electronic** group and disable the associated check box (A). Enable the appropriate check box in the **Function check** column (B). Please note that the "Accept" button must be pressed to confirm each entry.

Standard Area		Configurable Area		Status 1	Status 2	Simulation	Failure		Function Check		Out of Specification		Maintenance Required	
							Priority 0	Priority 0	Priority 0	Priority 0				
Bit#	Diagnostic Event	enable	mask	enable	mask	enable	mask	enable	mask	enable	mask	enable	mask	
31	Highest Severity Sensor	<input checked="" type="checkbox"/>	<input type="checkbox"/>	<input type="checkbox"/>	<input type="checkbox"/>	<input type="checkbox"/>	<input type="checkbox"/>	<input type="checkbox"/>	<input type="checkbox"/>	<input type="checkbox"/>	<input type="checkbox"/>	<input type="checkbox"/>	<input type="checkbox"/>	
30	Highest Severity Electronic	<input checked="" type="checkbox"/> (A)	<input type="checkbox"/>	<input type="checkbox"/>	<input type="checkbox"/>	<input type="checkbox"/>	<input type="checkbox"/>	<input checked="" type="checkbox"/> (B)	<input type="checkbox"/>	<input type="checkbox"/>	<input type="checkbox"/>	<input type="checkbox"/>	<input type="checkbox"/>	
29	Highest Severity Configuration	<input checked="" type="checkbox"/>	<input type="checkbox"/>	<input type="checkbox"/>	<input type="checkbox"/>	<input type="checkbox"/>	<input type="checkbox"/>	<input type="checkbox"/>	<input type="checkbox"/>	<input type="checkbox"/>	<input type="checkbox"/>	<input type="checkbox"/>	<input type="checkbox"/>	
28	Highest Severity Process	<input checked="" type="checkbox"/>	<input type="checkbox"/>	<input type="checkbox"/>	<input type="checkbox"/>	<input type="checkbox"/>	<input type="checkbox"/>	<input type="checkbox"/>	<input type="checkbox"/>	<input type="checkbox"/>	<input type="checkbox"/>	<input type="checkbox"/>	<input type="checkbox"/>	
27	High Severity Sensor	<input type="checkbox"/>	<input type="checkbox"/>	<input type="checkbox"/>	<input type="checkbox"/>	<input type="checkbox"/>	<input type="checkbox"/>	<input checked="" type="checkbox"/>	<input type="checkbox"/>	<input type="checkbox"/>	<input type="checkbox"/>	<input type="checkbox"/>	<input type="checkbox"/>	
26	High Severity Electronic	<input type="checkbox"/>	<input type="checkbox"/>	<input type="checkbox"/>	<input type="checkbox"/>	<input type="checkbox"/>	<input type="checkbox"/>	<input checked="" type="checkbox"/>	<input type="checkbox"/>	<input type="checkbox"/>	<input type="checkbox"/>	<input type="checkbox"/>	<input type="checkbox"/>	
25	High Severity Configuration	<input type="checkbox"/>	<input type="checkbox"/>	<input type="checkbox"/>	<input type="checkbox"/>	<input type="checkbox"/>	<input type="checkbox"/>	<input checked="" type="checkbox"/>	<input type="checkbox"/>	<input type="checkbox"/>	<input type="checkbox"/>	<input type="checkbox"/>	<input type="checkbox"/>	
24	High Severity Process	<input type="checkbox"/>	<input type="checkbox"/>	<input type="checkbox"/>	<input type="checkbox"/>	<input type="checkbox"/>	<input type="checkbox"/>	<input checked="" type="checkbox"/>	<input type="checkbox"/>	<input type="checkbox"/>	<input type="checkbox"/>	<input type="checkbox"/>	<input type="checkbox"/>	
23	Low Severity Sensor	<input type="checkbox"/>	<input type="checkbox"/>	<input type="checkbox"/>	<input type="checkbox"/>	<input type="checkbox"/>	<input type="checkbox"/>	<input type="checkbox"/>	<input type="checkbox"/>	<input checked="" type="checkbox"/>	<input type="checkbox"/>	<input type="checkbox"/>	<input type="checkbox"/>	
22	Low Severity Electronic	<input type="checkbox"/>	<input type="checkbox"/>	<input type="checkbox"/>	<input type="checkbox"/>	<input type="checkbox"/>	<input type="checkbox"/>	<input type="checkbox"/>	<input type="checkbox"/>	<input checked="" type="checkbox"/>	<input type="checkbox"/>	<input type="checkbox"/>	<input type="checkbox"/>	
21	Low Severity Configuration	<input type="checkbox"/>	<input type="checkbox"/>	<input type="checkbox"/>	<input type="checkbox"/>	<input type="checkbox"/>	<input type="checkbox"/>	<input type="checkbox"/>	<input type="checkbox"/>	<input checked="" type="checkbox"/>	<input type="checkbox"/>	<input type="checkbox"/>	<input type="checkbox"/>	
20	Low Severity Process	<input type="checkbox"/>	<input type="checkbox"/>	<input type="checkbox"/>	<input type="checkbox"/>	<input type="checkbox"/>	<input type="checkbox"/>	<input type="checkbox"/>	<input type="checkbox"/>	<input checked="" type="checkbox"/>	<input type="checkbox"/>	<input type="checkbox"/>	<input type="checkbox"/>	
19	Lowest Severity Sensor	<input type="checkbox"/>	<input type="checkbox"/>	<input type="checkbox"/>	<input type="checkbox"/>	<input type="checkbox"/>	<input type="checkbox"/>	<input type="checkbox"/>	<input type="checkbox"/>	<input type="checkbox"/>	<input type="checkbox"/>	<input checked="" type="checkbox"/>	<input type="checkbox"/>	
18	Lowest Severity Electronic	<input type="checkbox"/>	<input type="checkbox"/>	<input type="checkbox"/>	<input type="checkbox"/>	<input type="checkbox"/>	<input type="checkbox"/>	<input type="checkbox"/>	<input type="checkbox"/>	<input type="checkbox"/>	<input type="checkbox"/>	<input checked="" type="checkbox"/>	<input type="checkbox"/>	
17	Lowest Severity Configuration	<input type="checkbox"/>	<input type="checkbox"/>	<input type="checkbox"/>	<input type="checkbox"/>	<input type="checkbox"/>	<input type="checkbox"/>	<input type="checkbox"/>	<input type="checkbox"/>	<input type="checkbox"/>	<input type="checkbox"/>	<input checked="" type="checkbox"/>	<input type="checkbox"/>	
16	Lowest Severity Process	<input type="checkbox"/>	<input type="checkbox"/>	<input type="checkbox"/>	<input type="checkbox"/>	<input type="checkbox"/>	<input type="checkbox"/>	<input type="checkbox"/>	<input type="checkbox"/>	<input type="checkbox"/>	<input type="checkbox"/>	<input checked="" type="checkbox"/>	<input type="checkbox"/>	

Please ensure that the corresponding bit is set in at least one of the assignment parameters for each event group. Otherwise no category will be transmitted with the event via the bus, and the control system will therefore generally ignore the presence of the event.

The detection of diagnostic events and the transmission of the messages on the bus is configured on the FieldCare **Expert** → **Field Device Diagnostic** → **Configuration** page. The "Mask" column is used for the transmission of the message on the bus. It must be noted that device messages can still be transmitted by polling the active bits in Status 1 and 2. The mask check box acts as a negative check box, i.e. if a field is selected the associated events are not transmitted on the bus. The Resource Block must be in the **Auto** mode for the status information to be transmitted on the bus.

7.9.3 Configurable area

The event category can be individually defined for the following events - irrespective of the event group they are assigned to in the default setting:

- **115:** Sensor overpressure
- **120:** Sensor low pressure
- **715:** Sensor over temperature
- **717:** Transmitter over temperature
- **718:** Transmitter under temperature
- **720:** Sensor under temperature
- **726:** Sensor temperature error-overrange
- **727:** Sensor pressure error-overrange
- **730:** LRV user limits exceeded
- **731:** URV user limits exceeded
- **732:** LRV-Temp. user limits exceeded
- **733:** URV-Temp. user limits exceeded
- **740:** Calculation Overflow, bad configuration

To change the event category, the event must first be assigned to one of the bits 1 to 15. The **FF912ConfigArea_1** to **FF912ConfigArea_15** parameters in the **DIAGNOSTIC (TRDDIAG)** Block are used for this purpose. Then the corresponding bit can be set from **0** to **1** in the desired assignment parameter.

Example

Error **115 "Sensor overpressure"** should no longer be categorized as **Out of Specification (S)**, and should be categorized as **Function check (C)** instead.

1. In the FieldCare navigation window, go to **Expert** → **Field Device Diagnostic** → **Configuration**.

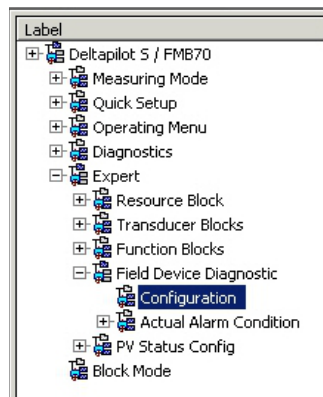

- Select the "Configurable area" tab. In the factory setting, all the bits in the **Configurable Area Bits** column have the value **not assigned (A)**.

Standard Area		Configurable Area	Status 1	Status 2	Simulation	Failure		Function Check		Out of Specification		Maintenance Required	
Bit#	Diagnostic Event	(A) (B)				enable	mask	enable	mask	enable	mask	enable	mask
15	not assigned	(A) (B)	<input type="checkbox"/>	<input type="checkbox"/>	<input type="checkbox"/>	<input type="checkbox"/>	<input type="checkbox"/>	<input type="checkbox"/>	<input type="checkbox"/>	<input type="checkbox"/>	<input type="checkbox"/>	<input type="checkbox"/>	<input type="checkbox"/>
14	not assigned		<input type="checkbox"/>	<input type="checkbox"/>	<input type="checkbox"/>	<input type="checkbox"/>	<input type="checkbox"/>	<input type="checkbox"/>	<input type="checkbox"/>	<input type="checkbox"/>	<input type="checkbox"/>	<input type="checkbox"/>	<input type="checkbox"/>
13	not assigned		<input type="checkbox"/>	<input type="checkbox"/>	<input type="checkbox"/>	<input type="checkbox"/>	<input type="checkbox"/>	<input type="checkbox"/>	<input type="checkbox"/>	<input type="checkbox"/>	<input type="checkbox"/>	<input type="checkbox"/>	<input type="checkbox"/>
12	not assigned		<input type="checkbox"/>	<input type="checkbox"/>	<input type="checkbox"/>	<input type="checkbox"/>	<input type="checkbox"/>	<input type="checkbox"/>	<input type="checkbox"/>	<input type="checkbox"/>	<input type="checkbox"/>	<input type="checkbox"/>	<input type="checkbox"/>
11	not assigned		<input type="checkbox"/>	<input type="checkbox"/>	<input type="checkbox"/>	<input type="checkbox"/>	<input type="checkbox"/>	<input type="checkbox"/>	<input type="checkbox"/>	<input type="checkbox"/>	<input type="checkbox"/>	<input type="checkbox"/>	<input type="checkbox"/>
10	not assigned		<input type="checkbox"/>	<input type="checkbox"/>	<input type="checkbox"/>	<input type="checkbox"/>	<input type="checkbox"/>	<input type="checkbox"/>	<input type="checkbox"/>	<input type="checkbox"/>	<input type="checkbox"/>	<input type="checkbox"/>	<input type="checkbox"/>
9	not assigned		<input type="checkbox"/>	<input type="checkbox"/>	<input type="checkbox"/>	<input type="checkbox"/>	<input type="checkbox"/>	<input type="checkbox"/>	<input type="checkbox"/>	<input type="checkbox"/>	<input type="checkbox"/>	<input type="checkbox"/>	<input type="checkbox"/>
8	not assigned		<input type="checkbox"/>	<input type="checkbox"/>	<input type="checkbox"/>	<input type="checkbox"/>	<input type="checkbox"/>	<input type="checkbox"/>	<input type="checkbox"/>	<input type="checkbox"/>	<input type="checkbox"/>	<input type="checkbox"/>	<input type="checkbox"/>
7	not assigned		<input type="checkbox"/>	<input type="checkbox"/>	<input type="checkbox"/>	<input type="checkbox"/>	<input type="checkbox"/>	<input type="checkbox"/>	<input type="checkbox"/>	<input type="checkbox"/>	<input type="checkbox"/>	<input type="checkbox"/>	<input type="checkbox"/>
6	not assigned		<input type="checkbox"/>	<input type="checkbox"/>	<input type="checkbox"/>	<input type="checkbox"/>	<input type="checkbox"/>	<input type="checkbox"/>	<input type="checkbox"/>	<input type="checkbox"/>	<input type="checkbox"/>	<input type="checkbox"/>	<input type="checkbox"/>
5	not assigned		<input type="checkbox"/>	<input type="checkbox"/>	<input type="checkbox"/>	<input type="checkbox"/>	<input type="checkbox"/>	<input type="checkbox"/>	<input type="checkbox"/>	<input type="checkbox"/>	<input type="checkbox"/>	<input type="checkbox"/>	<input type="checkbox"/>
4	not assigned		<input type="checkbox"/>	<input type="checkbox"/>	<input type="checkbox"/>	<input type="checkbox"/>	<input type="checkbox"/>	<input type="checkbox"/>	<input type="checkbox"/>	<input type="checkbox"/>	<input type="checkbox"/>	<input type="checkbox"/>	<input type="checkbox"/>
3	not assigned		<input type="checkbox"/>	<input type="checkbox"/>	<input type="checkbox"/>	<input type="checkbox"/>	<input type="checkbox"/>	<input type="checkbox"/>	<input type="checkbox"/>	<input type="checkbox"/>	<input type="checkbox"/>	<input type="checkbox"/>	<input type="checkbox"/>
2	not assigned		<input type="checkbox"/>	<input type="checkbox"/>	<input type="checkbox"/>	<input type="checkbox"/>	<input type="checkbox"/>	<input type="checkbox"/>	<input type="checkbox"/>	<input type="checkbox"/>	<input type="checkbox"/>	<input type="checkbox"/>	<input type="checkbox"/>
1	not assigned		<input type="checkbox"/>	<input type="checkbox"/>	<input type="checkbox"/>	<input type="checkbox"/>	<input type="checkbox"/>	<input type="checkbox"/>	<input type="checkbox"/>	<input type="checkbox"/>	<input type="checkbox"/>	<input type="checkbox"/>	<input type="checkbox"/>

- Select one of these bits (here **Configurable Area Bit 15**, for instance) and select the **Sensor overpressure (B)** option from the associated picklist. Confirm your choice by pressing "Accept".
- Enable the check box for the bit concerned (here: **Configurable Area Bit 15 (C)**). Confirm your choice by pressing "Accept".

Additional information:

The "Status 1" and "Status 2" tabs indicate whether an event is active.

Standard Area		Configurable Area	Status 1	Status 2	Simulation	Failure		Function Check		Out of Specification		Maintenance Required	
Bit#	Diagnostic Event		active	active		active	active	active	active	active	active	active	active
31	Highest Severity Sensor		<input type="checkbox"/>	<input type="checkbox"/>	<input type="checkbox"/>	<input type="checkbox"/>	<input type="checkbox"/>	<input type="checkbox"/>	<input type="checkbox"/>	<input type="checkbox"/>	<input type="checkbox"/>	<input type="checkbox"/>	<input type="checkbox"/>
30	Highest Severity Electronic		<input type="checkbox"/>	<input type="checkbox"/>	<input type="checkbox"/>	<input type="checkbox"/>	<input type="checkbox"/>	<input type="checkbox"/>	<input type="checkbox"/>	<input type="checkbox"/>	<input type="checkbox"/>	<input type="checkbox"/>	<input type="checkbox"/>
29	Highest Severity Configuration		<input type="checkbox"/>	<input type="checkbox"/>	<input type="checkbox"/>	<input type="checkbox"/>	<input type="checkbox"/>	<input type="checkbox"/>	<input type="checkbox"/>	<input type="checkbox"/>	<input type="checkbox"/>	<input type="checkbox"/>	<input type="checkbox"/>
28	Highest Severity Process		<input type="checkbox"/>	<input type="checkbox"/>	<input type="checkbox"/>	<input type="checkbox"/>	<input type="checkbox"/>	<input type="checkbox"/>	<input type="checkbox"/>	<input type="checkbox"/>	<input type="checkbox"/>	<input type="checkbox"/>	<input type="checkbox"/>
27	High Severity Sensor		<input type="checkbox"/>	<input type="checkbox"/>	<input type="checkbox"/>	<input type="checkbox"/>	<input type="checkbox"/>	<input type="checkbox"/>	<input type="checkbox"/>	<input type="checkbox"/>	<input type="checkbox"/>	<input type="checkbox"/>	<input type="checkbox"/>
26	High Severity Electronic		<input type="checkbox"/>	<input type="checkbox"/>	<input type="checkbox"/>	<input type="checkbox"/>	<input type="checkbox"/>	<input type="checkbox"/>	<input type="checkbox"/>	<input type="checkbox"/>	<input type="checkbox"/>	<input type="checkbox"/>	<input type="checkbox"/>
25	High Severity Configuration		<input type="checkbox"/>	<input type="checkbox"/>	<input type="checkbox"/>	<input type="checkbox"/>	<input type="checkbox"/>	<input type="checkbox"/>	<input type="checkbox"/>	<input type="checkbox"/>	<input type="checkbox"/>	<input type="checkbox"/>	<input type="checkbox"/>
24	High Severity Process		<input type="checkbox"/>	<input type="checkbox"/>	<input type="checkbox"/>	<input type="checkbox"/>	<input type="checkbox"/>	<input type="checkbox"/>	<input type="checkbox"/>	<input type="checkbox"/>	<input type="checkbox"/>	<input type="checkbox"/>	<input type="checkbox"/>
23	Low Severity Sensor		<input type="checkbox"/>	<input type="checkbox"/>	<input type="checkbox"/>	<input type="checkbox"/>	<input type="checkbox"/>	<input type="checkbox"/>	<input type="checkbox"/>	<input type="checkbox"/>	<input type="checkbox"/>	<input type="checkbox"/>	<input type="checkbox"/>
22	Low Severity Electronic		<input type="checkbox"/>	<input type="checkbox"/>	<input type="checkbox"/>	<input type="checkbox"/>	<input type="checkbox"/>	<input type="checkbox"/>	<input type="checkbox"/>	<input type="checkbox"/>	<input type="checkbox"/>	<input type="checkbox"/>	<input type="checkbox"/>
21	Low Severity Configuration		<input type="checkbox"/>	<input type="checkbox"/>	<input type="checkbox"/>	<input type="checkbox"/>	<input type="checkbox"/>	<input type="checkbox"/>	<input type="checkbox"/>	<input type="checkbox"/>	<input type="checkbox"/>	<input type="checkbox"/>	<input type="checkbox"/>
20	Low Severity Process		<input type="checkbox"/>	<input type="checkbox"/>	<input type="checkbox"/>	<input type="checkbox"/>	<input type="checkbox"/>	<input type="checkbox"/>	<input type="checkbox"/>	<input type="checkbox"/>	<input type="checkbox"/>	<input type="checkbox"/>	<input type="checkbox"/>
19	Lowest Severity Sensor		<input type="checkbox"/>	<input type="checkbox"/>	<input type="checkbox"/>	<input type="checkbox"/>	<input type="checkbox"/>	<input type="checkbox"/>	<input type="checkbox"/>	<input type="checkbox"/>	<input type="checkbox"/>	<input type="checkbox"/>	<input type="checkbox"/>
18	Lowest Severity Electronic		<input type="checkbox"/>	<input type="checkbox"/>	<input type="checkbox"/>	<input type="checkbox"/>	<input type="checkbox"/>	<input type="checkbox"/>	<input type="checkbox"/>	<input type="checkbox"/>	<input type="checkbox"/>	<input type="checkbox"/>	<input type="checkbox"/>
17	Lowest Severity Configuration		<input type="checkbox"/>	<input type="checkbox"/>	<input type="checkbox"/>	<input type="checkbox"/>	<input type="checkbox"/>	<input type="checkbox"/>	<input type="checkbox"/>	<input type="checkbox"/>	<input type="checkbox"/>	<input type="checkbox"/>	<input type="checkbox"/>
16	Lowest Severity Process		<input type="checkbox"/>	<input type="checkbox"/>	<input type="checkbox"/>	<input type="checkbox"/>	<input type="checkbox"/>	<input type="checkbox"/>	<input type="checkbox"/>	<input type="checkbox"/>	<input type="checkbox"/>	<input type="checkbox"/>	<input type="checkbox"/>

Changing the error category for **Sensor overpressure** does not affect an error that already exists. The new category is only assigned if this error occurs again after the change has been made. The "Status 1" and "Status 2" tabs indicate whether an event is active.

Standard Area		Configurable Area		Status 1	Status 2	Simulation			
						Failure 	Function Check 	Out of Specification 	Maintenance Required
Bit#	Diagnostic Event			active		active		active	active
15	not assigned			<input type="checkbox"/>		<input type="checkbox"/>	<input type="checkbox"/>	<input type="checkbox"/>	<input type="checkbox"/>
14	not assigned			<input type="checkbox"/>		<input type="checkbox"/>	<input type="checkbox"/>	<input type="checkbox"/>	<input type="checkbox"/>
13	not assigned			<input type="checkbox"/>		<input type="checkbox"/>	<input type="checkbox"/>	<input type="checkbox"/>	<input type="checkbox"/>
12	not assigned			<input type="checkbox"/>		<input type="checkbox"/>	<input type="checkbox"/>	<input type="checkbox"/>	<input type="checkbox"/>
11	not assigned			<input type="checkbox"/>		<input type="checkbox"/>	<input type="checkbox"/>	<input type="checkbox"/>	<input type="checkbox"/>
10	not assigned			<input type="checkbox"/>		<input type="checkbox"/>	<input type="checkbox"/>	<input type="checkbox"/>	<input type="checkbox"/>
9	not assigned			<input type="checkbox"/>		<input type="checkbox"/>	<input type="checkbox"/>	<input type="checkbox"/>	<input type="checkbox"/>
8	not assigned			<input type="checkbox"/>		<input type="checkbox"/>	<input type="checkbox"/>	<input type="checkbox"/>	<input type="checkbox"/>
7	not assigned			<input type="checkbox"/>		<input type="checkbox"/>	<input type="checkbox"/>	<input type="checkbox"/>	<input type="checkbox"/>
6	not assigned			<input type="checkbox"/>		<input type="checkbox"/>	<input type="checkbox"/>	<input type="checkbox"/>	<input type="checkbox"/>
5	not assigned			<input type="checkbox"/>		<input type="checkbox"/>	<input type="checkbox"/>	<input type="checkbox"/>	<input type="checkbox"/>
4	not assigned			<input type="checkbox"/>		<input type="checkbox"/>	<input type="checkbox"/>	<input type="checkbox"/>	<input type="checkbox"/>
3	not assigned			<input type="checkbox"/>		<input type="checkbox"/>	<input type="checkbox"/>	<input type="checkbox"/>	<input type="checkbox"/>
2	not assigned			<input type="checkbox"/>		<input type="checkbox"/>	<input type="checkbox"/>	<input type="checkbox"/>	<input type="checkbox"/>
1	not assigned			<input type="checkbox"/>		<input type="checkbox"/>	<input type="checkbox"/>	<input type="checkbox"/>	<input type="checkbox"/>

The "Simulation" tab makes it possible to simulate an event.

Standard Area		Configurable Area		Status 1	Status 2	Simulation			
						Simulate En/Disable: <input type="text" value="Disabled"/>			
Bit#	Diagnostic Event	simulation	active	Bit#	Diagnostic Event	simulation	active		
31	Highest Severity Sensor	<input type="checkbox"/>	<input type="checkbox"/>	15	not assigned	<input type="checkbox"/>	<input type="checkbox"/>		
30	Highest Severity Electronic	<input type="checkbox"/>	<input type="checkbox"/>	14	not assigned	<input type="checkbox"/>	<input type="checkbox"/>		
29	Highest Severity Configuration	<input type="checkbox"/>	<input type="checkbox"/>	13	not assigned	<input type="checkbox"/>	<input type="checkbox"/>		
28	Highest Severity Process	<input type="checkbox"/>	<input type="checkbox"/>	12	not assigned	<input type="checkbox"/>	<input type="checkbox"/>		
27	High Severity Sensor	<input type="checkbox"/>	<input type="checkbox"/>	11	not assigned	<input type="checkbox"/>	<input type="checkbox"/>		
26	High Severity Electronic	<input type="checkbox"/>	<input type="checkbox"/>	10	not assigned	<input type="checkbox"/>	<input type="checkbox"/>		
25	High Severity Configuration	<input type="checkbox"/>	<input type="checkbox"/>	9	not assigned	<input type="checkbox"/>	<input type="checkbox"/>		
24	High Severity Process	<input type="checkbox"/>	<input type="checkbox"/>	8	not assigned	<input type="checkbox"/>	<input type="checkbox"/>		
23	Low Severity Sensor	<input type="checkbox"/>	<input type="checkbox"/>	7	not assigned	<input type="checkbox"/>	<input type="checkbox"/>		
22	Low Severity Electronic	<input type="checkbox"/>	<input type="checkbox"/>	6	not assigned	<input type="checkbox"/>	<input type="checkbox"/>		
21	Low Severity Configuration	<input type="checkbox"/>	<input type="checkbox"/>	5	not assigned	<input type="checkbox"/>	<input type="checkbox"/>		
20	Low Severity Process	<input type="checkbox"/>	<input type="checkbox"/>	4	not assigned	<input type="checkbox"/>	<input type="checkbox"/>		
19	Lowest Severity Sensor	<input type="checkbox"/>	<input type="checkbox"/>	3	not assigned	<input type="checkbox"/>	<input type="checkbox"/>		
18	Lowest Severity Electronic	<input type="checkbox"/>	<input type="checkbox"/>	2	not assigned	<input type="checkbox"/>	<input type="checkbox"/>		
17	Lowest Severity Configuration	<input type="checkbox"/>	<input type="checkbox"/>	1	not assigned	<input type="checkbox"/>	<input type="checkbox"/>		
16	Lowest Severity Process	<input type="checkbox"/>	<input type="checkbox"/>						

7.9.4 Transmission of independent event messages on the bus

Event priority

Event messages are only transmitted on the bus if their priority is between 2 and 15. Priority 1 events are displayed but are not transmitted on the bus. Priority 0 events are ignored. All events are assigned the priority 0 in the factory setting. It is possible to change the priority individually for the four assignment parameters.

Example

The priority of the "Failure" category is to be set to "2" .

1. In the FieldCare navigation window, go to **Expert** → **Field Device Diagnostics** → **Configuration**

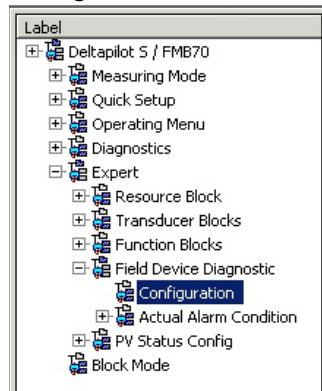

2. Select the "Standard area" tab and set the priority to "2" in the "Failure" column (D).

Standard Area		Configurable Area	Status 1	Status 2	Simulation
		Failure 	Function Check 	Out of Specification 	Maintenance Required
		Priority 0	Priority 0	Priority 0	Priority 0
Bit#	Diagnostic Event	enable	mask	enable	mask
31	Highest Severity Sensor	<input checked="" type="checkbox"/>	<input type="checkbox"/>	<input type="checkbox"/>	<input type="checkbox"/>
30	Highest Severity Electronic	<input checked="" type="checkbox"/>	<input type="checkbox"/>	<input type="checkbox"/>	<input type="checkbox"/>
29	Highest Severity Configuration	<input checked="" type="checkbox"/>	<input type="checkbox"/>	<input type="checkbox"/>	<input type="checkbox"/>
28	Highest Severity Process	<input checked="" type="checkbox"/>	<input type="checkbox"/>	<input type="checkbox"/>	<input type="checkbox"/>
27	High Severity Sensor	<input type="checkbox"/>	<input type="checkbox"/>	<input checked="" type="checkbox"/>	<input type="checkbox"/>
26	High Severity Electronic	<input type="checkbox"/>	<input type="checkbox"/>	<input checked="" type="checkbox"/>	<input type="checkbox"/>
25	High Severity Configuration	<input type="checkbox"/>	<input type="checkbox"/>	<input checked="" type="checkbox"/>	<input type="checkbox"/>
24	High Severity Process	<input type="checkbox"/>	<input type="checkbox"/>	<input checked="" type="checkbox"/>	<input type="checkbox"/>
23	Low Severity Sensor	<input type="checkbox"/>	<input type="checkbox"/>	<input type="checkbox"/>	<input checked="" type="checkbox"/>
22	Low Severity Electronic	<input type="checkbox"/>	<input type="checkbox"/>	<input checked="" type="checkbox"/>	<input type="checkbox"/>
21	Low Severity Configuration	<input type="checkbox"/>	<input type="checkbox"/>	<input checked="" type="checkbox"/>	<input type="checkbox"/>
20	Low Severity Process	<input type="checkbox"/>	<input type="checkbox"/>	<input checked="" type="checkbox"/>	<input type="checkbox"/>
19	Lowest Severity Sensor	<input type="checkbox"/>	<input type="checkbox"/>	<input type="checkbox"/>	<input checked="" type="checkbox"/>
18	Lowest Severity Electronic	<input type="checkbox"/>	<input type="checkbox"/>	<input type="checkbox"/>	<input checked="" type="checkbox"/>
17	Lowest Severity Configuration	<input type="checkbox"/>	<input type="checkbox"/>	<input type="checkbox"/>	<input checked="" type="checkbox"/>
16	Lowest Severity Process	<input type="checkbox"/>	<input type="checkbox"/>	<input type="checkbox"/>	<input checked="" type="checkbox"/>

Suppression of certain events

It is possible to suppress certain events during transmission on the bus using a mask. While these events are still displayed, they are not transmitted as alert objects on the bus. This mask check box can be found in FieldCare under **Expert** → **Field Device Diagnostic** → **Configuration**. The mask check box acts as a negative check box, i.e. if a field is selected the associated events are not transmitted on the bus.

7.9.5 Overview of the settings made and the current events

1. In the FieldCare navigation window, go to **Diagnostics → Alarm Indication (Polling)**

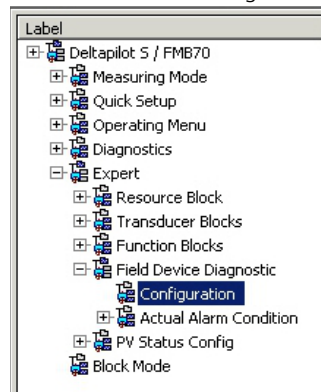

2. The following overview is displayed:
 - "Troubleshooting information" if an event has occurred
 - "Setting made" in the configurable area
 - "Current events" in the various categories

7.9.6 Information about the current events

1. In the FieldCare navigation window, go to **Expert → Field Device Diagnostic → Actual Alarm Condition**

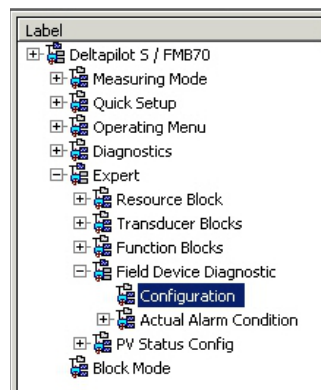

2. The following overview is displayed:
 - "Troubleshooting information" if an event has occurred
 - "FF912 Field Diagnostic Profile" version
 - "Information about the current events" in the various categories

7.9.7 Setting the status of the flexible alarms

The event category can be individually defined for the following events - irrespective of the event group they are assigned to in the default setting:

- 115: Sensor overpressure
- 120: Sensor low pressure
- 715: Sensor over temperature
- 717: Transmitter over temperature
- 718: Transmitter under temperature
- 720: Sensor under temperature
- 726: Sensor temperature error-overrange
- 727: Sensor pressure error-overrange
- 730: LRV user limits exceeded
- 731: URV user limits exceeded
- 732: LRV-Temp. user limits exceeded
- 733: URV-Temp. user limits exceeded
- 740: Calculation Overflow, bad configuration

To change the measured value status (Bad, Uncertain, Good) assigned to an event, select the desired status from the picklist.

Example

The status "Bad" should be used for error 115 "Sensor overpressure" instead of the status "Uncertain".

1. In the FieldCare navigation window, go to **Expert** → **Field Device Diagnostics** → **PV Status Config**

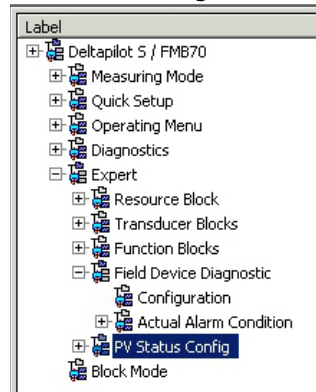

2. All the bits of the Status Select Events have the status "Uncertain" in the factory setting.

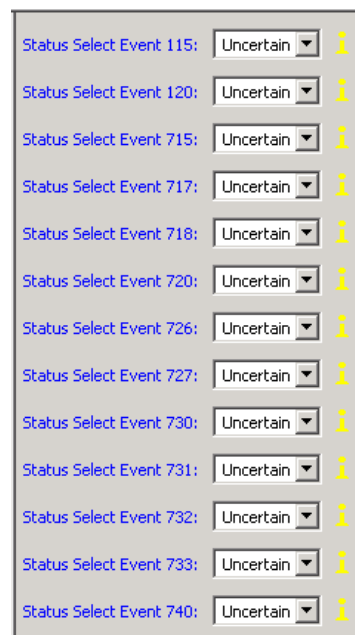

3. Select the option "Bad" for the "Status Select Event 115" row. Press ENTER to confirm your entries.

8 Maintenance

Keep the pressure compensation and GORE-TEX® filter (1) free from contamination.

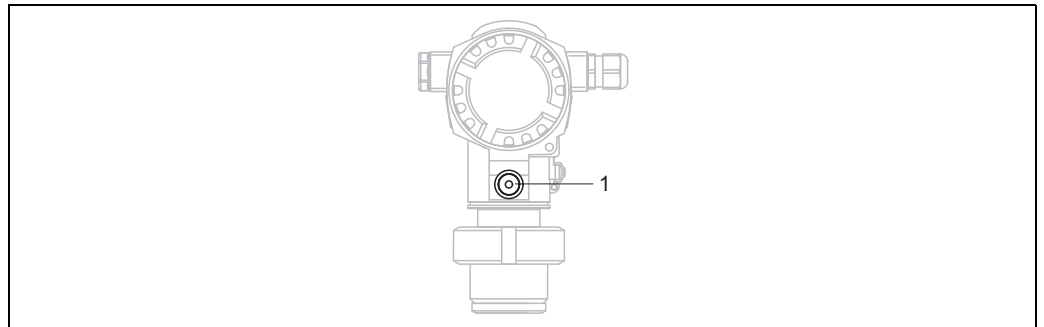

P01-FMB70xxx-17-xx-xx-xx-003

8.1 Exterior cleaning

Please note the following points when cleaning the measuring instrument:

- The cleaning agents used should not corrode the surface and the seals.
- Mechanical damage to the process membrane, e.g. due to sharp objects, must be avoided.

9 Diagnostics and troubleshooting

9.1 Troubleshooting

9.1.1 General errors

Error	Possible cause	Remedy
Device is not responding.	Supply voltage does not match the value indicated on the nameplate.	Connect the correct voltage.
	The polarity of the supply voltage is wrong.	Reverse polarity of supply voltage.
	Connecting cables are not in contact with the terminals.	Check the contacting of the cables and terminals and correct if necessary.
No display	Onsite display is set too bright or too dark.	<ul style="list-style-type: none"> ▪ Set the local display brighter by simultaneously pressing O and F . ▪ Set the local display darker by simultaneously pressing S and F .
	Connector for onsite display is not properly connected.	Connect the plug correctly.
	Onsite display is defective.	Replace onsite display.
Device is measuring incorrectly.	Parameter configuration error.	Check and correct parameter configuration (see below).

9.1.2 Message display:

- Onsite display:
 - The measured value display shows the message with the highest priority. → See the "Priority" column.
 - The ALARM STATUS parameter shows all the messages present in descending order of priority. You can scroll through all the messages present with the S key or O key.
- FieldCare
 - The DIAGNOSTIC_CODE/DIAGNOSE_CODE parameter displays the message with the highest priority.
 - See "Priority" column.
 - See also section 9.6 "Response of outputs to errors".
- Diagnose Transducer Block (FF configuration program):
 - The DIAGNOSTIC_CODE/DIAGNOSE_CODE parameter displays the message with the highest priority. → See also section 9.6 "Response of outputs to errors". Every message is also output as per the FOUNDATION Fieldbus Specification by means of the XD_ERROR and BLOCK_ERROR parameters in the Pressure, Service and DP Flow Block. Numbers are given for these parameters in the following table which are explained on 73.
- You can see a list of all the active alarms via the Diagnostic code/ACTUAL_ALARM_INFO parameter.
- You can view a list of alarms which are no longer active (event log) via the Last diag. code/ LAST_ALARM_INFO parameter.

9.2 Diagnostic information on onsite display

9.2.1 Diagnostic message

Faults detected by the self-monitoring system of the measuring instrument are displayed as a diagnostic message in alternation with the measured value display.

Error categories

F	<p>"Failure" A device error has occurred. The measured value is no longer valid.</p>
C	<p>"Function check" The device is in the service mode (e.g. during a simulation) or is self-monitoring.</p>
S	<p>"Out of specification" The device is being operated:</p> <ul style="list-style-type: none"> ▪ Outside its technical specifications (e.g. during startup or cleaning) ▪ Outside the parameter configuration undertaken by the user (e.g. pressure outside of nominal operating range)
M	<p>"Maintenance required" Maintenance is required. The measured value is still valid.</p>

Diagnostic event and event text

The fault can be identified by means of the diagnostic event. The event text helps you by providing information about the fault.

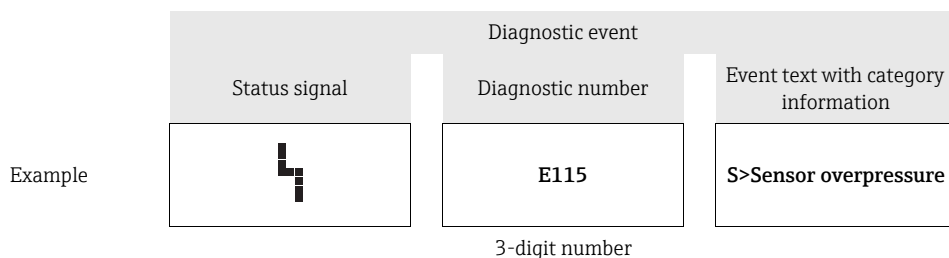

- If the device detects a defect in the onsite display during initialization, special error messages are generated. → See → 71, section 9.2.2 "Onsite display error messages" for the error messages.
- For support and further information, please contact Endress+Hauser Service.
- If the category of a diagnostic event is being changed, an empty field might be displayed instead of "F, C, S, M".

9.2.2 Onsite display error messages

If the device detects a defect in the onsite display during initialization, the following error messages can be displayed:

Message	Measure
Initialization, VU Electr. Defect A110	Replace onsite display.
Initialization, VU Electr. Defect A114	
Initialization, VU Electr. Defect A281	
Initialization, VU Checksum Err. A110	
Initialization, VU Checksum Err. A112	
Initialization, VU Checksum Err. A171	
Initialization	Supply voltage too low. Set supply voltage to the correct value.

9.3 Diagnostic event in the operating tool

If a diagnostic event is present in the operating tool, the status signal appears in the top left status area along with the corresponding symbol for diagnostic behavior in accordance with NAMUR NE 107:

- Failure (F)
- Function check (C)
- Maintenance required (M)
- Out of specification (S)

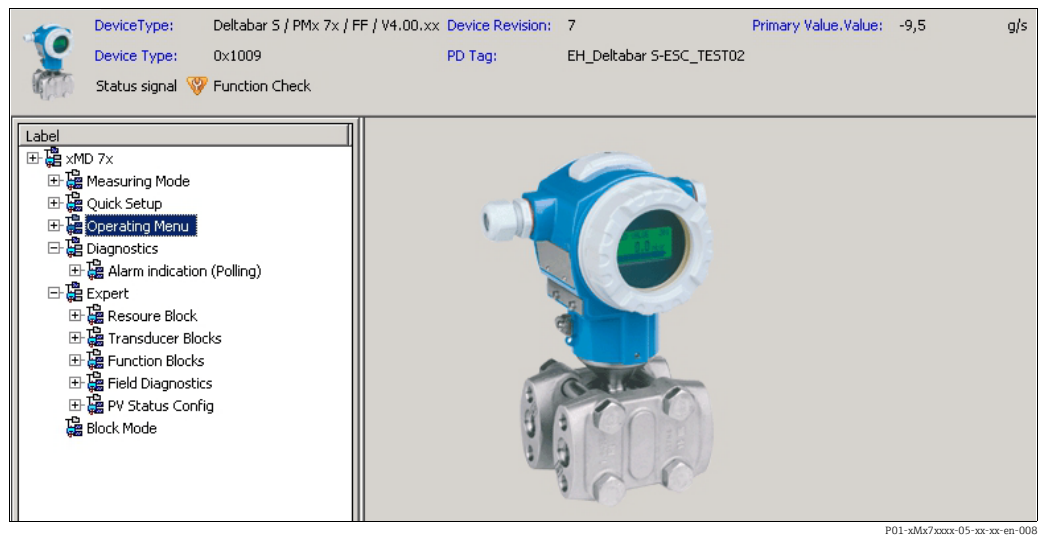

P01-xMx7xxxx-05-xx-xx-en-008

Calling up remedial measures

1. Navigate to the "Diagnostics" menu. The diagnostic event along with text about the event is displayed in the "Actual diagnostics" parameter.
2. On the right in the display area, hover the cursor over the "Actual diagnostics" parameter. A tool tip with remedial measures for the diagnostic event appears.

9.4 Diagnostic messages in the DIAGNOSTIC Transducer Block (TRDDIAG)

- The Actual Diagnostics parameter shows the message with the highest priority. Every message is also displayed as per the FOUNDATION Fieldbus Specification by means of the XD_ERROR and BLOCK_ERROR parameters.
- You can view the active alarm with the highest priority via the Diagnostics parameter.
- You can view the last alarm that is no longer active via the Last Diagnosis parameter.

9.4.1 Explanation of XD_ERROR, BLOCK_ERROR and response of outputs

Failure mode	Diagnostic Code	XD_ERROR Value Bit	XD_ERROR Text	BLOCK_ERROR Value Bit	BLOCK_ERROR Text	PRIMARY_VALUE (Status is set according to operating mode)	PRIMARY_VALUE_TYPE (Operating Mode)	TRANSDUCER Status Propagation (Impacted CHANNEL selection)
Alarm	747	17	General error	0	Other	BAD_SENSOR_FAILURE	Pressure, Level, Flow	All
	707	18	Calibration error	0	Other	BAD_NON_SPECIFIC	Level	Primary Value(1)
	711	18	Calibration error	0	Other	BAD_NON_SPECIFIC	Level, Flow	Primary Value(1) Totalizer 1 (6)
	713	18	Calibration error	0	Other	BAD_NON_SPECIFIC	Level	Primary Value(1)
	721	18	Calibration error	0	Other	BAD_NON_SPECIFIC	Level	Primary Value(1)
	722	18	Calibration error	0	Other	BAD_NON_SPECIFIC	Level	Primary Value(1)
	723	18	Calibration error	0	Other	BAD_NON_SPECIFIC	Flow	Primary Value(1) Totalizer 1 (6)
	741	18	Calibration error	0	Other	BAD_NON_SPECIFIC	Level	Primary Value(1)
	719	19	Configuration error	0	Other	BAD_NON_SPECIFIC	Level	Primary Value(1)
	750	18	Calibration error	0	Other	BAD_NON_SPECIFIC	Pressure, Level, Flow	Primary Value(1) Pressure(3) Maximum Pressure(4) Counter P > Pmax(5) Totalizer 1 (6)
	122	20	Electronics failure	7	Sensor failure	BAD_SENSOR_FAILURE	Pressure, Level, Flow	All
	101	20	Electronics failure	0	Other	BAD_SENSOR_FAILURE	Pressure, Level, Flow	All
	716	20	Electronics failure	0	Other	BAD_SENSOR_FAILURE	Pressure, Level, Flow	All
	725	20	Electronics failure	0	Other	BAD_SENSOR_FAILURE	Pressure, Level, Flow	All
	704	20	Electronics failure	7	Sensor failure	BAD_DEVICE_FAILURE	Pressure, Level, Flow	All
	703	20	Electronics failure	0	Other	BAD_DEVICE_FAILURE	Pressure, Level, Flow	All
	705	20	Electronics failure	0	Other	BAD_DEVICE_FAILURE	Pressure, Level, Flow	All
	737	20	Electronics failure	0	Other	BAD_DEVICE_FAILURE	Pressure, Level, Flow	All
	738	20	Electronics failure	0	Other	BAD_DEVICE_FAILURE	Pressure, Level, Flow	All
	739	20	Electronics failure	0	Other	BAD_DEVICE_FAILURE	Pressure, Level, Flow	All
742	20	Electronics failure	0	Other	BAD_DEVICE_FAILURE	Pressure, Level, Flow	All	
744	20	Electronics failure	0	Other	BAD_DEVICE_FAILURE	Pressure, Level, Flow	All	

Failure mode	Diagnostic Code	XD_ERROR Value Bit	XD_ERROR Text	BLOCK_ERROR Value Bit	BLOCK_ERROR Text	PRIMARY_VALUE (Status is set according to operating mode)	PRIMARY_VALUE_TYPE (Operating Mode)	TRANSDUCER Status Propagation (Impacted CHANNEL selection)
Alarm	743	20	Electronics failure	7	Sensor failure	BAD_DEVICE_FAILURE	Pressure, Level, Flow	All
	748	20	Electronics failure	7	Sensor failure	BAD_DEVICE_FAILURE	Pressure, Level, Flow	All
	113	20	Electronics failure	0	Other	BAD_DEVICE_FAILURE	Pressure, Level, Flow	All
	728	20	Electronics failure	0	Other	BAD_DEVICE_FAILURE	Pressure, Level, Flow	All
	729	20	Electronics failure	0	Other	BAD_DEVICE_FAILURE	Pressure, Level, Flow	All
	736	20	Electronics failure	0	Other	BAD_DEVICE_FAILURE	Pressure, Level, Flow	All
	110	23	Data integrity error	0	Other	BAD_DEVICE_FAILURE	Pressure, Level, Flow	All
	130	23	Data integrity error	0	Other	BAD_DEVICE_FAILURE	Pressure, Level, Flow	All
	131	23	Data integrity error	0	Other	GOOD	Pressure, Level, Flow	None
	132	23	Data integrity error	0	Other	BAD_DEVICE_FAILURE	Flow	Totalizer 1 (6)
	133	23	Data integrity error	0	Other	GOOD	Pressure, Level, Flow	None
	135	23	Data integrity error	0	Other	BAD_DEVICE_FAILURE	Pressure, Level, Flow	All
	121	23	Data integrity error	0	Other	BAD_DEVICE_FAILURE	Pressure, Level, Flow	All
Alarm/ warning	115	17	General error	0	Other	- BAD_NON_SPECIFIC - STATUS_UNCERTAIN - GOOD	Pressure, Level, Flow	Primary Value(1) Pressure(3) Maximum Pressure(4) Counter P > Pmax(5) Totalizer 1 (6)
	120	17	General error	0	Other	- BAD_NON_SPECIFIC - STATUS_UNCERTAIN - GOOD	Pressure, Level, Flow	Primary Value(1) Pressure(3) Maximum Pressure(4) Counter P > Pmax(5) Totalizer 1 (6)
	717	17	General error	0	Other	- BAD_NON_SPECIFIC - STATUS_UNCERTAIN - GOOD	Pressure, Level, Flow	All
	718	17	General error	0	Other	- BAD_NON_SPECIFIC - STATUS_UNCERTAIN - GOOD	Pressure, Level, Flow	All
	720	17	General error	0	Other	- BAD_NON_SPECIFIC - STATUS_UNCERTAIN - GOOD	Pressure, Level, Flow	Sensor Temperature(2)
	715	17	General error	7	Sensor failure	- BAD_NON_SPECIFIC - STATUS_UNCERTAIN - GOOD	Pressure, Level, Flow	Sensor Temperature(2)
	726	20	Electronics failure	7	Sensor failure	- BAD_NON_SPECIFIC - STATUS_UNCERTAIN - GOOD	Pressure, Level, Flow	All
	740	20	Electronics failure	7	Sensor failure	- BAD_NON_SPECIFIC - STATUS_UNCERTAIN - GOOD	Pressure, Level, Flow	All
	727	20	Electronics failure	7	Sensor failure	- BAD_NON_SPECIFIC - STATUS_UNCERTAIN - GOOD	Pressure, Level, Flow	All
	730	19	Configuration error	0	Other	GOOD	Pressure, Level, Flow	None
	731	19	Configuration error	0	Other	GOOD	Pressure, Level, Flow	None

Failure mode	Diagnostic Code	XD_ERROR Value Bit	XD_ERROR Text	BLOCK_ERROR Value Bit	BLOCK_ERROR Text	PRIMARY_VALUE (Status is set according to operating mode)	PRIMARY_VALUE_TYPE (Operating Mode)	TRANSDUCER Status Propagation (Impacted CHANNEL selection)
	732	19	Configuration error	0	Other	GOOD	Pressure, Level, Flow	None
	733	19	Configuration error	0	Other	GOOD	Pressure, Level, Flow	None
Warning	106	17	General error	0	Other	STATUS_UNCERTAIN	Pressure, Level, Flow	All
	134	17	General error	0	Other	GOOD	Pressure, Level, Flow	None
	116	17	General error	0	Other	- BAD_NON_SPECIFIC - STATUS_UNCERTAIN - GOOD	Pressure, Level, Flow	All
	701	17	General error	0	Other	UNCERTAIN_CONFIG_ERROR	Pressure, Level, Flow	All
	745	17	General error	0	Other	STATUS_UNCERTAIN	Pressure, Level, Flow	All
	613	17	General error	0	Other	UNCERTAIN_SIM	Pressure, Level, Flow	Primary Value(1) Maximum Pressure(4) Counter P > Pmax(5) Totalizer 1 (6)
	702	17	General error	0	Other	GOOD	Pressure, Level, Flow	None
	710	18	Calibration error	0	Other	GOOD	Pressure, Level, Flow	None
	602	19	Configuration error	0	Other	UNCERTAIN_CONFIG_ERROR	Level	Primary Value(1)
	604	19	Configuration error	0	Other	UNCERTAIN_CONFIG_ERROR	Level	Primary Value(1)
	746	20	Electronics failure	0	Other	STATUS_UNCERTAIN	Pressure, Level, Flow	All
	102	23	Data integrity error	0	Other	GOOD	Pressure, Level, Flow	Maximum Pressure(4) Counter P > Pmax(5)
	700	23	Data integrity error	0	Other	STATUS_UNCERTAIN	Pressure, Level, Flow	All
	706	23	Data integrity error	0	Other	GOOD	Pressure, Level, Flow	None

9.5 Overview of diagnostic events

9.5.1 Failure (F)

Diagnostic code	Failure mode	Message/description	XD_ERROR Value Bit	BLOCK_ERROR Value Bit	Cause	Measure	Priority
101	Alarm	F>Sensor electronic EEPROM error	20	0	<ul style="list-style-type: none"> - Electromagnetic effects are greater than specifications in the technical data. (→ See section 10.) This message normally only appears briefly. - Sensor defect. 	<ul style="list-style-type: none"> - Wait a few minutes. - Restart the device. Perform reset (Code 62). - Block off electromagnetic effects or eliminate source of disturbance. - Replace sensor. 	19
110	Alarm	F>Checksum error in EEPROM: configuration segment	23	0	<ul style="list-style-type: none"> - The supply voltage is disconnected when writing. - Electromagnetic effects are greater than specifications in the technical data. (→ See section 10.) - Main electronics defect. 	<ul style="list-style-type: none"> - Reestablish supply voltage. If necessary, perform reset (code 7864) and recalibrate the device. - Block off electromagnetic effects or eliminate sources of disturbance. - Replace main electronics. 	6
113	Alarm	F>ROM failure in transmitter electronic.	20	0	<ul style="list-style-type: none"> - Main electronics defect. 	<ul style="list-style-type: none"> - Replace main electronics. 	1
121	Alarm	F>Checksum error in factory segment of EEPROM	23	0	<ul style="list-style-type: none"> - Main electronics defect. 	<ul style="list-style-type: none"> - Replace main electronics. 	5
122	Alarm	F>Sensor not connected	20	7	<ul style="list-style-type: none"> - Cable connection sensor – main electronics disconnected. - Electromagnetic effects are greater than specifications in the technical data. (→ See section 10.) - Main electronics defect. - Sensor defect. 	<ul style="list-style-type: none"> - Check cable connection and repair if necessary. - Block off electromagnetic effects or eliminate source of disturbance. - Replace main electronics. - Replace sensor. 	14
130	Alarm	F>EEPROM is defect.	23	0	<ul style="list-style-type: none"> - Main electronics defect. 	<ul style="list-style-type: none"> - Replace main electronics. 	11
131	Alarm	F>Checksum error in EEPROM: min/max segment	23	0	<ul style="list-style-type: none"> - Main electronics defect. 	<ul style="list-style-type: none"> - Replace main electronics. 	9
133	Alarm	F>Checksum error in History EEPROM	23	0	<ul style="list-style-type: none"> - An error occurred when writing. - Main electronics defect. 	<ul style="list-style-type: none"> - Perform reset (code 7864) and recalibrate the device. - Replace main electronics. 	8
135	Alarm	F>Checksum error in EEPROM FF segment	23	0	<ul style="list-style-type: none"> - Main electronics defect. 	<ul style="list-style-type: none"> - Replace main electronics. 	10
703	Alarm	F>Measurement error	20	0	<ul style="list-style-type: none"> - Fault in the main electronics. - Main electronics defect. 	<ul style="list-style-type: none"> - Briefly disconnect device from the power supply. - Replace main electronics. 	24
705	Alarm	F>Measurement error	20	0	<ul style="list-style-type: none"> - Fault in the main electronics. - Main electronics defect. 	<ul style="list-style-type: none"> - Briefly disconnect device from the power supply. - Replace main electronics. 	23
716	Alarm	F>Process membrane broken	20	0	<ul style="list-style-type: none"> - Sensor defect. 	<ul style="list-style-type: none"> - Replace sensor. - Reduce pressure. 	26

Diagnostic code	Failure mode	Message/description	XD_ERROR Value Bit	BLOCK_ERROR Value Bit	Cause	Measure	Priority
725	Alarm	F>Sensor connection error, cycle disturbance	20	0	<ul style="list-style-type: none"> - Electromagnetic effects are greater than specifications in the technical data. (→ See section 10.) - Setscrew loose. - Sensor or main electronics defect. 	<ul style="list-style-type: none"> - Block off electromagnetic effects or eliminate source of disturbance. - Retighten setscrew with 1 Nm (0.74 lbf ft) (see section 4.4.5). - Replace sensor or main electronics. 	27
728	Alarm	F>RAM error	20	0	<ul style="list-style-type: none"> - Fault in the main electronics. - Main electronics defect. 	<ul style="list-style-type: none"> - Briefly disconnect device from the power supply. - Replace main electronics. 	2
729	Alarm	F>RAM error	20	0	<ul style="list-style-type: none"> - Fault in the main electronics. - Main electronics defect. 	<ul style="list-style-type: none"> - Briefly disconnect device from the power supply. - Replace main electronics. 	3
736	Alarm	F>RAM error	20	0	<ul style="list-style-type: none"> - Fault in the main electronics. - Main electronics defect. 	<ul style="list-style-type: none"> - Briefly disconnect device from the power supply. - Replace main electronics. 	4
737	Alarm	F>Measurement error	20	0	<ul style="list-style-type: none"> - Fault in the main electronics. - Main electronics defect. 	<ul style="list-style-type: none"> - Briefly disconnect device from the power supply. - Replace main electronics. 	22
738	Alarm	F>Measurement error	20	0	<ul style="list-style-type: none"> - Fault in the main electronics. - Main electronics defect. 	<ul style="list-style-type: none"> - Briefly disconnect device from the power supply. - Replace main electronics. 	21
739	Alarm	F>Measurement error	20	0	<ul style="list-style-type: none"> - Fault in the main electronics. - Main electronics defect. 	<ul style="list-style-type: none"> - Briefly disconnect device from the power supply. - Replace main electronics. 	25
742	Alarm	F>Sensor connection error (upload)	20	0	<ul style="list-style-type: none"> - Electromagnetic effects are greater than specifications in the technical data. (→ See section 10.) This message normally only appears briefly. - Cable connection sensor – main electronics disconnected. - Sensor defect. 	<ul style="list-style-type: none"> - Wait a few minutes. - Perform reset (code 7864) and recalibrate the device. - Check cable connection and repair if necessary. - Replace sensor. 	20
743	Alarm	F>Electronic PCB error during initialization	20	7	<ul style="list-style-type: none"> - Electromagnetic effects are greater than specifications in the technical data. (→ See section 10.) This message normally only appears briefly. - Main electronics defect. 	<ul style="list-style-type: none"> - Wait a few minutes. - Restart device. Perform reset (Code 62). - Replace main electronics. 	15 / 16
744	Alarm	F>Main electronic PCB error	20	0	<ul style="list-style-type: none"> - Electromagnetic effects are greater than specifications in the technical data. (→ See section 10.) - Main electronics defect. 	<ul style="list-style-type: none"> - Restart device. Perform reset (Code 62). - Block off electromagnetic effects or eliminate source of disturbance. - Replace main electronics. 	12
747	Alarm	F>Sensor software not compatible to electronics	17	0	<ul style="list-style-type: none"> - Sensor does not suit the device (electronic sensor nameplate). 	<ul style="list-style-type: none"> - Replace sensor with a suitable sensor. 	18

Diagnostic code	Failure mode	Message/description	XD_ERROR Value Bit	BLOCK_ERROR Value Bit	Cause	Measure	Priority
748	Alarm	F>Memory failure in signal processor	20	7	<ul style="list-style-type: none"> - Electromagnetic effects are greater than specifications in the technical data. (→ See section 10.) - Main electronics defect. 	<ul style="list-style-type: none"> - Block off electromagnetic effects or eliminate source of disturbance. - Replace main electronics. 	17

9.5.2 Function check (C)

Diagnostic code	Failure mode	Message/description	XD_ERROR Value Bit	BLOCK_ERROR Value Bit	Cause	Measure	Priority
106	Warning	C>Downloading - please wait	17	0	- Downloading.	- Wait for download to complete.	61
602	Warning	C>Linearization curve not monotone	19	0	- The linearization table is not monotonic increasing.	- Add to or correct linearization table. Then accept linearization table again.	67
604	Warning	C>Linearization table invalid. Min. 2 points.	19	0	Note! From software version "03.00.00.xx" onwards, there is no min. span for the Y-points.		
					- The linearization table has fewer than 2 points.	<ol style="list-style-type: none"> 1. Add to linearization table. Perform the linearization again if necessary. 2. Correct the linearization table and accept it again. 	68
613	Warning	C>Simulation is active	17	0	- Simulation is switched on, i.e. the device is not measuring at present.	- Switch off simulation.	70
701	Warning	C>Adjustment outside sensor nominal range	17	0	- The calibration carried out would cause the sensor nominal range to be exceeded or undershot.	- Carry out calibration again.	63
704	Alarm	C>Measurement error	20	7	<ul style="list-style-type: none"> - Fault in the main electronics. - Main electronics defect. 	<ul style="list-style-type: none"> - Briefly disconnect device from the power supply. - Replace main electronics. 	13
707	Alarm	C>X-VAL. (TAB_XY_VALUE) of lin. table out of edit limits	18	0	- At least one X-VALUE (TAB_XY_VALUE) in the linearization table is either below the value for SCALE_IN, EU_0/HYDR. PRESS. MIN. or LINEAR_LEVEL_MIN/MIN. LEVEL or above the value for SCALE_IN, EU_100/HYDR. PRESS. MAX. or LINEAR_LEVEL_MAX/HEIGHT MAX.	- Perform calibration again (→ See Operating Instructions BA00303P, parameter description, Section 5).	45
710	Warning	B>Set span too small. Not allowed	18	0	- Values for calibration (e.g. lower range value and upper range value) are too close together.	- Adjust calibration to suit sensor (→ See Operating Instructions BA00303P, parameter description, parameter CAL_MIN_SPAN/MINIMUM SPAN parameter).	60
					- The sensor was replaced and the customer-specific configuration does not suit the sensor.	<ul style="list-style-type: none"> - Adjust calibration to suit sensor. - Replace sensor with a suitable sensor. 	
					- Unsuitable download carried out.	- Check configuration and perform download again.	

Diagnostic code	Failure mode	Message/description	XD_ERROR Value Bit	BLOCK_ERROR Value Bit	Cause	Measure	Priority
711	Alarm	C>LRV or URV out of edit limits	18	0	<ul style="list-style-type: none"> - Lower range value and/or upper range value exceed or fall below the sensor range limits. - The sensor was replaced and the customer-specific configuration does not suit the sensor. - Unsuitable download carried out. 	<ul style="list-style-type: none"> - Reconfigure lower range value and/or upper range value to suit the sensor. Pay attention to position adjustment. - Reconfigure lower range value and/or upper range value to suit the sensor. Pay attention to position adjustment. - Replace sensor with a suitable sensor. - Check configuration and perform download again. 	37
713	Alarm	C>100% POINT (LEVEL_100_PERCENT_VALUE) level out of edit limits	18	0	<ul style="list-style-type: none"> - The sensor was replaced. 	<ul style="list-style-type: none"> - Carry out calibration again. 	46
719	Alarm	C>Y-VAL (TAB_XY_VALUE) of lin. table out of edit limits	19	0	<ul style="list-style-type: none"> - At least one Y-VALUE (TAB_XY_VALUE) in the linearization table is below the SCALE_OUT, EU_0/TANK CONTENT MIN. or above the SCALE_OUT, EU_100/TANK CONTENT MAX. 	<ul style="list-style-type: none"> - Carry out calibration again. (→ See Operating Instructions BA00303P, parameter description, Section 5). 	47
721	Alarm	C>ZERO POSITION (LEVEL_OFFSET) level out of edit limits	18	0	<ul style="list-style-type: none"> - LEVEL MIN (LINEAR_LEVEL_MIN) or LEVEL MAX (LINEAR_LEVEL_MAX) has been changed. 	<ul style="list-style-type: none"> - Perform reset (code 2710) and recalibrate the device. 	48
722	Alarm	C>EMPTY CALIB. (SCALE_OUT, EU_0) or FULL CALIB. (SCALE_OUT, EU_100) out of edit limits	18	0	<ul style="list-style-type: none"> - LINEAR_LEVEL_MIN/LEVEL MIN or LINEAR_LEVEL_MAX/LEVEL MAX has been changed. 	<ul style="list-style-type: none"> - Perform reset (code 2710) and recalibrate the device. 	49/50
723	Alarm	C>MAX. FLOW (SCALE_OUT, EU_100) out of edit limits	18	0	<ul style="list-style-type: none"> - FLOW_TYPE/FLOW-MEAS. TYPE has been changed. 	<ul style="list-style-type: none"> - Carry out calibration again. 	51
741	Alarm	C>TANK HEIGHT (LEVEL_TANK_HEIGHT) out of edit limits	18	0	<ul style="list-style-type: none"> - LINEAR_LEVEL_MIN/LEVEL MIN or LINEAR_LEVEL_MAX/LEVEL MAX has been changed. 	<ul style="list-style-type: none"> - Perform reset (code 2710) and recalibrate the device. 	52
746	Warning	C>Sensor connection error - initializing	20	0	<ul style="list-style-type: none"> - Electromagnetic effects are greater than specifications in the technical data. (→ See section 10.) This message normally only appears briefly. - Overpressure or low pressure present. 	<ul style="list-style-type: none"> - Wait a few minutes. - Restart device. Perform reset (Code 7864). - Block off electromagnetic effects or eliminate source of disturbance. - Reduce or increase pressure. 	28

Diagnostic code	Failure mode	Message/description	XD_ERROR Value Bit	BLOCK_ERROR Value Bit	Cause	Measure	Priority
750	Warning	C>Configuration not permitted	18	0	<ul style="list-style-type: none"> - By means of the operation profile, options were selected for the configuration of the device but the options do not suit one another. For example, if the option "1" (linearization table) was selected for LIN_TYPE and the unit "1347 (m³/s)" was selected for PRIMARY_VALUE_UNIT. 	<ul style="list-style-type: none"> - Check configuration. - Perform reset (code 7864) and recalibrate the device. 	53

9.5.3 Maintenance required (M)

Diagnostic code	Failure mode	Message/description	XD_ERROR Value Bit	BLOCK_ERROR Value Bit	Cause	Measure	Priority
102	Warning	M>Checksum error in EEPROM: peakhold segment	23	0	<ul style="list-style-type: none"> – Main electronics defect. Correct measurement can continue as long as you do not need the peak hold indicator function. 	<ul style="list-style-type: none"> – Replace main electronics. 	62
116	Warning	M>Download error, repeat download	17	0	<ul style="list-style-type: none"> – The file is corrupt. – During the download, the data are not correctly transmitted to the processor, e.g. due to open cable connections, spikes (ripple) on the supply voltage or electromagnetic effects. 	<ul style="list-style-type: none"> – Use another file. – Check cable connection PC – transmitter. – Block off electromagnetic effects or eliminate sources of disturbance. – Perform reset (code 7864) and recalibrate the device. – Repeat download. 	38
134	Warning	M>EEPROM lifetime WARNING	17	0	<ul style="list-style-type: none"> – Writing too often to EEPROM. 	<ul style="list-style-type: none"> – Reduce write accessing to EEPROM. 	65
700	Warning	M>Last configuration not stored	23	0	<ul style="list-style-type: none"> – An error occurred when writing or reading configuration data or the power supply was disconnected. – Main electronics defect. 	<ul style="list-style-type: none"> – Perform reset (code 7864) and recalibrate the device. – Replace main electronics. 	63
702	Warning	M>HistoROM data not consistent	17	0	<ul style="list-style-type: none"> – Data were not written correctly to the HistoROM, e.g. if the HistoROM was detached during the writing process. – HistoROM does not have any data. 	<ul style="list-style-type: none"> – Repeat upload. – Perform reset (code 7864) and recalibrate the device. – Copy suitable data to the HistoROM. (→ 41, section 6.6.1 "Copying configuration data".) 	64
706	Warning	M>Configuration in HistoROM and device not identical.	23	0	<ul style="list-style-type: none"> – Configuration (parameters) in the HistoROM and in the device not identical. 	<ul style="list-style-type: none"> – Copy data from the device to the HistoROM. (→ 41, section 6.6.1 "Copying configuration data".) – Copy data from the HistoROM to the device. (→ 41, section 6.6.1 "Copying configuration data".) The message remains if the HistoROM and the device have different software versions. The message goes out if you copy the data from the device to the HistoROM. – Device reset codes such as 1 or 40864 do not have any effect on the HistoROM. That means that if you do a reset, the configurations in the HistoROM and in the device may not be the same. 	69

Diagnostic code	Failure mode	Message/description	XD_ERROR Value Bit	BLOCK_ERROR Value Bit	Cause	Measure	Priority
740	Alarm/warning	M>Calculation overflow, bad configuration	20	7	<ul style="list-style-type: none"> Level measuring mode: the measured pressure has undershot the value for SCALE_IN, EU_0/HYDR. PRESS. MIN. or overshoot the value for SCALE_IN, EU_100/HYDR. PRESS MAX. Level measuring mode: the measured level did not reach the LEVEL MIN value or exceeded the LEVEL MAX value. 	<ul style="list-style-type: none"> Check configuration and carry out calibration again if necessary. Select a device with a suitable measuring range. Check configuration and recalibrate the device if necessary (→ see Operating Instructions BA00303P, parameter description, LEVEL MIN. parameter). 	29
745	Warning	M>Sensor data unknown	17	0	<ul style="list-style-type: none"> Sensor does not suit the device (electronic sensor nameplate). Device continues measuring. 	<ul style="list-style-type: none"> Replace sensor with a suitable sensor. 	66

9.5.4 Out of specification (S)



Diagnostic code	Failure mode	Message/description	XD_ERROR Value Bit	BLOCK_ERROR Value Bit	Cause	Measure	Priority
115	Alarm/warning	S>Sensor overpressure	17	0	<ul style="list-style-type: none"> Overpressure present. Sensor defect. 	<ul style="list-style-type: none"> Reduce pressure until message disappears. Replace sensor. 	31
120	Alarm/warning	S>Sensor low pressure	17	0	<ul style="list-style-type: none"> Pressure too low. Sensor defect. 	<ul style="list-style-type: none"> Increase pressure until message disappears. Replace sensor. 	32
715	Alarm/warning	S>Sensor over temperature	17	7	<ul style="list-style-type: none"> The temperature measured in the sensor is higher than the upper nominal temperature of the sensor. (→ See also Operating Instructions BA00303P, parameter description for TEMPERATURE_1_SENSOR_LIMIT_HIGH/Tmax SENSOR) Unsuitable download carried out. 	<ul style="list-style-type: none"> Reduce process temperature/ ambient temperature. Check configuration and perform download again. 	34
717	Alarm/warning	S>Transmitter over temperature	17	0	<ul style="list-style-type: none"> The temperature measured in the electronics is greater than the upper nominal temperature of the electronics (+88 °C +190 °F). Unsuitable download carried out. 	<ul style="list-style-type: none"> Reduce ambient temperature. Check configuration and perform download again. 	36
718	Alarm/warning	S>Transmitter under temperature	17	0	<ul style="list-style-type: none"> The temperature measured in the electronics is less than the lower nominal temperature of the electronics (-43 °C -45 °F). Unsuitable download carried out. 	<ul style="list-style-type: none"> Increase ambient temperature. Insulate device if necessary. Check configuration and perform download again. 	37

Diagnostic code	Failure mode	Message/description	XD_ERROR Value Bit	BLOCK_ERROR Value Bit	Cause	Measure	Priority
720	Alarm/warning	S>Sensor under temperature	17	0	<ul style="list-style-type: none"> - The temperature measured in the sensor is less than the lower nominal temperature of the sensor (→ see Operating Instructions BA00303P, parameter description, TEMPERATURE_1_SENSOR_LIMIT_LOW/Tmin SENSOR parameter). - Unsuitable download carried out. - Loose connection at sensor cable 	<ul style="list-style-type: none"> - Increase process temperature/ambient temperature. - Check configuration and perform download again. - Wait a short period of time and tighten the connection, or avoid loose connection. 	35
726	Alarm/warning	S>Sensor temperature error - overrange	20	7	<ul style="list-style-type: none"> - Electromagnetic effects are greater than specifications in the technical data. (→ See section 10.) - Process temperature is outside permitted range. - Sensor defect. 	<ul style="list-style-type: none"> - Block off electromagnetic effects or eliminate source of disturbance. - Check temperature present, reduce or increase if necessary. - If the process temperature is within the permitted range, replace sensor. 	33
727	Alarm/warning	S>Sensor pressure error - overrange	20	7	<ul style="list-style-type: none"> - Electromagnetic effects are greater than specifications in the technical data. (→ See section 10.) - Pressure is outside permitted range. - Sensor defect. 	<ul style="list-style-type: none"> - Block off electromagnetic effects or eliminate source of disturbance. - Check pressure present, reduce or increase if necessary. - If the pressure is within the permitted range, replace sensor. 	30
730	Alarm/warning	S>Pmin ALARM WINDOW (PRESSURE_1_USER_LOW_LIMIT) undershot	19	0	<ul style="list-style-type: none"> - Pressure measured value has undershot the value specified for the PRESSURE_1_USER_LOW_LIMIT/Pmin ALARM WINDOW parameter. - Loose connection at sensor cable 	<ul style="list-style-type: none"> - Check system/pressure measured value. - Change value for PRESSURE_1_USER_LOW_LIMIT/Pmin ALARM WINDOW if necessary. (→ See also Operating Instructions BA00303P, parameter description) - Wait a short period of time and tighten the connection, or avoid loose connection. 	55
731	Alarm/warning	S>Pmax ALARM WINDOW (PRESSURE_1_USER_HIGH_LIMIT) overshoot	19	0	<ul style="list-style-type: none"> - Pressure measured value has overshoot the value specified for the PRESSURE_1_USER_HIGH_LIMIT/Pmax ALARM WINDOW parameter. 	<ul style="list-style-type: none"> - Check system/pressure measured value. - Change value for PRESSURE_1_USER_HIGH_LIMIT/Pmax ALARM WINDOW if necessary. (→ See also Operating Instructions BA00303P, parameter description) 	54

Diagnostic code	Failure mode	Message/description	XD_ERROR Value Bit	BLOCK_ERROR Value Bit	Cause	Measure	Priority
732	Alarm/warning	S>Tmin ALARM WINDOW (TEMPERATURE_1_USER_LOW_LIMIT) undershot	19	0	<ul style="list-style-type: none"> - Temperature measured value has undershot the value specified for the TEMPERATURE_1_USER_LOW_LIMIT/ Tmin ALARM WINDOW parameter. - Loose connection at sensor cable 	<ul style="list-style-type: none"> - Check system/temperature measured value. - Change value for TEMPERATURE_1_USER_LOW_LIMIT/ Tmin ALARM WINDOW if necessary. (→ See also Operating Instructions BA00303P, parameter description) - Wait a short period of time and tighten the connection, or avoid loose connection. 	57
733	Alarm/warning	S>Tmax ALARM WINDOW (TEMPERATURE_1_USER_HIGH_LIMIT) overshoot	19	0	<ul style="list-style-type: none"> - Temperature measured value has overshoot the value specified for the TEMPERATURE_1_USER_HIGH_LIMIT/ Tmax ALARM WINDOW parameter. 	<ul style="list-style-type: none"> - Check system/temperature measured value. - Change value for TEMPERATURE_1_USER_HIGH_LIMIT/ Tmax ALARM WINDOW if necessary. (→ See also Operating Instructions BA00303P, parameter description) 	56

9.6 Response of outputs to errors

The device makes a distinction between the output behavior "Alarm", "Warning" and "Error".
 → See the following table and → 71, section 9.2 "Diagnostic information on onsite display". Certain problems can be assigned the "GOOD" status via FF communication, see section 9.4.1.

Output	A (Alarm)	W (Warning)	E (Error: Alarm/Warning)
FOUNDATION Fieldbus	The process variable in question is transmitted with the status BAD.	Device continues measuring. The process variable in question is transmitted with the status UNCERTAIN.	For this error, you can enter whether the device should react as in the event of an alarm or as in the event of a warning. See appropriate column for "Alarm" or "Warning" (→ see Operating Instructions BA00303P, parameter description, REACTION_ON_ALARM_NR/SELECT_ALARM_TYPE parameter). The GOOD status can also be assigned to the individual error via the parameters FF912_STATUS_SELECT_1 to FF912_STATUS_SELECT_131.
Onsite display	<ul style="list-style-type: none"> - The measured value and message are displayed alternately - Measured value display:  -symbol is permanently displayed. Message display <ul style="list-style-type: none"> - A + 3-digit number such as A122 and - Description 	<ul style="list-style-type: none"> - The measured value and message are displayed alternately - Measured value display:  -symbol flashes. Message display: <ul style="list-style-type: none"> - W + 3-digit number such as W613 and - Description 	<ul style="list-style-type: none"> - The measured value and message are displayed alternately - Measured value display: see corresponding "Alarm" or "Warning" column Message display: <ul style="list-style-type: none"> - E + 3-digit number such as E713 and - Description
Remote operation (FF configuration program/FieldCare)	In the event of an alarm, the ALARM STATUS ¹⁾ parameter displays a 3-digit number such as 122 for "Sensor connection error, incorrect data".	In the case of a warning, the ALARM_STATUS ¹⁾ parameter displays a 3-digit number such as 613 for "Simulation is active".	In the case of an error, the ALARM_STATUS ¹⁾ parameter displays a 3-digit number such as 731 for "Pmax ALARM WINDOW undershot".

1) FF configuration program: Diagnostic Transducer Block. Menu path FieldCare: OPERATING MENU → MESSAGES

9.6.1 Analog Input Block

If the Analog Input Block receives an input or simulation value with the status BAD, the Analog Input Block uses the failure mode defined in the FSAFE_TYPE¹ parameter.

The following options are available by means of the FSAFE_TYPE parameter:

- Last Good Value
The last valid value is used for further processing with the status UNCERTAIN.
- Fail SafeValue
The value specified by means of the FSAFE_VALUE¹ parameter is used for further processing with the status UNCERTAIN.
- Wrong Value
The current value is used for further processing with the status BAD.

Factory setting:

- FSAFE_TYPE: FsafeValue
- FSAFE_VALUE: 0

The failure mode is also activated if the "Out of service" option was selected by means of the MODE_BLK parameter, "Target" element.

¹ These parameters are not available by means of the FieldCare operating program.

9.7 Confirming messages

Depending on the settings for the ALARM_HOLD_ON_TIME/ALARM DISPL. TIME and ACKNOWLEDGE_ALARM_MODE/ACK. ALARM MODE parameters, the following measures should be taken to clear a message:

Settings ¹⁾	Measures
<ul style="list-style-type: none"> - ALARM_HOLD_ON_TIME/ ALARM DISPL. TIME = 0 s - ACKNOWLEDGE_ALARM_MODE /ACK. ALARM MODE = Off 	<ul style="list-style-type: none"> - Rectify cause of the message (see also section 9.5).
<ul style="list-style-type: none"> - ALARM_HOLD_ON_TIME/ ALARM DISPL. TIME > n s - ACKNOWLEDGE_ALARM_MODE /ACK. ALARM MODE = Off 	<ul style="list-style-type: none"> - Rectify cause of the message (see also section 9.5). - Wait for the alarm display time to elapse.
<ul style="list-style-type: none"> - ALARM_HOLD_ON_TIME/ ALARM DISPL. TIME = 0 s - ACKNOWLEDGE_ALARM_MODE /ACK. ALARM MODE = On 	<ul style="list-style-type: none"> - Rectify cause of the message (see also section 9.5). - Confirm message using ACKNOWLEDGE_ALARM/ ACK. ALARM parameter.
<ul style="list-style-type: none"> - ALARM_HOLD_ON_TIME/ ALARM DISPL. TIME > n s - ACKNOWLEDGE_ALARM_MODE /ACK. ALARM MODE = On 	<ul style="list-style-type: none"> - Rectify cause of the message (see also section 9.5). - Confirm message using ACKNOWLEDGE_ALARM/ ACK. ALARM parameter. - Wait for the alarm display time to elapse. If a message appears and the alarm display time elapses before the message has been acknowledged, the message will be cleared once it has been acknowledged.

1) FF configuration program: The parameters are in the Diagnostic Transducer Blocks.
FieldCare: Menu path for ALARM DISPL. TIME and ACK. ALARM MODE: OPERATING MENU → DIAGNOSTICS → MESSAGES

9.8 Repair

The Endress+Hauser repair concept provides for measuring instruments to have a modular design and that the customer can also carry out repairs (→  87 "Spare parts").

- For certified devices, please consult the "Repair of Ex-certified devices" section.
- For more information on service and spare parts contact the Endress+Hauser Service. (→ See www.endress.com/worldwide.)

9.9 Repair of Ex-certified devices

WARNING

Incorrect repair can compromise electrical safety!

Explosion hazard!

When repairing Ex-certified devices, please note the following:

- Repairs to Ex-certified devices must be carried out by Endress+Hauser Service or by specialist personnel according to national regulations.
- Relevant standards, national hazardous area regulations and Safety Instructions and Certificates must be observed.
- Only genuine Endress+Hauser spare parts may be used.
- When ordering spare parts, please check the device designation on the nameplate. Only replace parts with identical parts.
- Electronic inserts or sensors already in use in a standard instrument may not be used as spare parts for a certified device.
- Carry out repairs according to the instructions. After repairs, the device must fulfill the requirements of the specified individual tests.
- A certified device may only be converted into another certified variant by Endress+Hauser.

9.10 Spare parts

- Some replaceable measuring instrument components are identified by means of a spare part nameplate. This contains information about the spare part.
- All the spare parts for the measuring instrument, along with the order code, are listed in the W@M Device Viewer (www.endress.com/deviceviewer) and can be ordered here. If available, users can also download the associated Installation Instructions.



Measuring instrument serial number:

- Located on the device and spare part nameplate.
- Can be read out via the "DEVICE SERIAL No." parameter in the "TRANSMITTER DATA" submenu.

9.11 Returns

The measuring instrument must be returned if it is in need of repair or a factory calibration, or if the wrong measuring instrument has been delivered or ordered. Legal specifications require Endress+Hauser, as an ISO-certified company, to follow certain procedures when handling products that are in contact with the medium.

To ensure swift, safe and professional device returns, please read the return procedures and conditions on the Endress+Hauser website at www.services.endress.com/return-material.

9.12 Disposal

When disposing, ensure that the materials of the device components are separated and processed accordingly.

9.13 Software history

Date	Software version	Software changes
08.2008	03.00.zz	Original software. Compatible with: - FieldCare version 2.15.00
01.2013	04.00.zz	FF912 Field Diagnostic Profile Integration

10 Technical data

For technical data, please refer to Technical Information Deltapilot S TI00416P.

11 Appendix

11.1 Assignment of English parameter names on the onsite display

Display ID	German parameter name	English parameter name
001	EINHEIT DICHTe	DENSITY UNIT
003	EINHEIT HÖHE	HEIGHT UNIT
004	ABGLEICH VOLL – QUICK SETUP	FULL CALIB. – QUICK SETUP
004	ABGLEICH VOLL – Füllstandwahl "Füllstd. Easy Druck"	FULL CALIB. – "Level easy pressure" level selection
004	ABGLEICH VOLL – Füllstandwahl "Füllstd. Easy Höhe"	FULL CALIB. – "Level easy height" level selection
005	DRUCK VOLL	FULL PRESSURE
006	HÖHE VOLL	FULL HEIGHT
007	DICHTE ABGLEICH	ADJUST DENSITY
008	ABGLEICHMODUS – Füllstandwahl "Füllstd. Easy Druck"	CALIBRATION MODE – "Level easy pressure" level selection
008	ABGLEICHMODUS – Füllstandwahl "Füllstd. Easy Höhe"	CALIBRATION MODE – "Level easy height" level selection
009	HÖHE LEER	EMPTY HEIGHT
010	ABGLEICH LEER – QUICK SETUP	EMPTY CALIB. – QUICK SETUP
010	ABGLEICH LEER – Füllstandwahl "Füllstd. Easy Druck"	EMPTY CALIB. – "Level easy pressure" level selection
010	ABGLEICH LEER – Füllstandwahl "Füllstd. Easy Höhe"	EMPTY CALIB. – "Level easy height" level selection
011	DRUCK LEER	EMPTY PRESSURE
014	DOWNLOADFUNKTION	DOWNLOAD SELECT
020	FÜLLSTANDWAHL	LEVEL SELECTION
023	AUSGABEEINHEIT – Füllstandwahl "Füllstd. Easy Druck"	OUTPUT UNIT – "Level easy pressure" level selection
023	AUSGABEEINHEIT – Füllstandwahl "Füllstd. Easy Höhe"	OUTPUT UNIT – "Level easy height" level selection
025	DICHTE PROZESS	PROCESS DENSITY
046	DIAGNOSE CODE	ALARM STATUS
047	RÜCKSETZEN	ENTER RESET CODE
048	FREIGABECODE	INSERT PIN NO
050	FÜLLSTAND V. LIN	LEVEL BEFORE LIN
060	EINHEIT DRUCK	PRESS. ENG. UNIT
075	BEN. EINHEIT P	CUSTOMER UNIT P
079	SPRACHE	LANGUAGE
247	WERT DÄMPFUNG	DAMPING VALUE
250	SERIENNR SENSOR	SENSOR SER. No.
264	SOFTWARE VERSION	SOFTWARE VERSION
266	HARDWARE REV.	HARDWARE REV.
301	DRUCK GEMESSEN – Betriebsart "Druck"	PRESSURE – "Pressure" measuring mode
301	DRUCK GEMESSEN – Betriebsart "Füllstand"	PRESSURE – "Level" measuring mode
311	MAX. DURCHFLUSS	MAX. FLOW
313	EINHEIT VOLUMEN – Füllstandtyp "Linear"	UNIT VOLUME – "Linear" level mode
313	EINHEIT VOLUMEN – Füllstandtyp "Druck mit Kennlinie"	UNIT VOLUME – "Pressure linearized" level mode
313	EINHEIT VOLUMEN – Füllstandtyp "Höhe mit Kennlinie"	UNIT VOLUME – "Height linearized" level mode
314	ABGLEICH LEER – QUICK SETUP	EMPTY CALIB. – QUICK SETUP
314	ABGLEICH LEER – Füllstandtyp "Linear"	EMPTY CALIB. – "Linear" level mode
314	ABGLEICH LEER – Füllstandtyp "Höhe mit Kennlinie"	EMPTY CALIB. – "Height linearized" level mode
315	ABGLEICH VOLL – QUICK SETUP	FULL CALIB. – QUICK SETUP
315	ABGLEICH VOLL – Füllstandtyp "Druck mit Kennlinie"	FULL CALIB. – "Pressure linearized" level mode
315	ABGLEICH VOLL – Füllstandtyp "Höhe mit Kennlinie"	FULL CALIB. – "Height linearized" level mode
316	DICHTE ABGLEICH – Füllstandtyp "Linear"	ADJUST DENSITY – "Linear" level mode
316	DICHTE ABGLEICH – Füllstandtyp "Höhe mit Kennlinie"	ADJUST DENSITY – "Height linearized" level mode
316	DICHTE ABGLEICH – Erweit. Abgleich "Füllstand"	ADJUST DENSITY – "Level" extended setup
317	FAKT. BEN. EINH. P	CUST. UNIT. FACT. P
318	TEMP. EINHEIT – Betriebsart "Druck"	TEMP. ENG. UNIT – "Pressure" measuring mode
318	TEMP. EINHEIT – Betriebsart "Füllstand"	TEMP. ENG. UNIT – "Level" measuring mode
318	TEMP. EINHEIT – Betriebsart "Durchfluss"	TEMP. ENG. UNIT – "Flow" measuring mode
319	LAGEOFFSET	CALIB. OFFSET

Display ID	German parameter name	English parameter name
329	FAKT. BEN. EINH. S1	FACT. U.U. TOTAL.1
330	FAKT. BEN. EINH. S2	FACT. U.U. TOTAL.2
332	Pmin PROZESS	Pmin ALARM WINDOW
333	Pmax PROZESS	Pmax ALARM WINDOW
334	Tmin PROZESS	Tmin ALARM WINDOW
335	Tmax PROZESS	Tmax ALARM WINDOW
336	ALARMVERZÖGERUNG	ALARM DELAY
339	KONTRAST ANZEIGE	DISPLAY CONTRAST
350	GERÄTEBEZEICHNG	DEVICE DESIGN.
352	KONFIG ZÄHLER	CONFIG RECORDER
354	SERIENNR TRANSM.	DEVICE SERIAL No.
357	TEMP ELEKTRONIK	PCB TEMPERATURE
358	Tmin ELEKTRONIK	Allowed Min. TEMP
359	Tmax ELEKTRONIK	Allowed Max. TEMP
360	MAT. ANSCHL. +	MAT. PROC. CONN. +
361	MAT. ANSCHL. -	MAT. PROC. CONN. -
362	MAT. DICHTUNG	SEAL TYPE
363	SCHREIBSCHUTZ HW	DIP STATUS
365	MAT. MEMBRAN	MAT. MEMBRANE
366	FÜLLÖL	FILLING FLUID
367	TEMP. SENSOR	SENSOR TEMP.
368	Tmin SENSOR	Tmin SENSOR
369	Tmax SENSOR	Tmax SENSOR
370	TANKINHALT	TANK CONTENT
378	TENDENZ MESSWERT	MEAS. VAL. TREND
380	ZÄHLER P > Pmax	COUNTER: P > Pmax
383	MAXIMALER DRUCK	MAX. MEAS. PRESS.
386	SERIENNR ELEKTR.	ELECTR. SERIAL NO.
389	BETRIEBSART	MEASURING MODE
392	ABGLEICHMODUS – Füllstandtyp "Linear"	CALIBRATION MODE – "Linear" level mode
	ABGLEICHMODUS – Füllstandtyp "Höhe mit Kennlinie"	CALIBRATION MODE – "Height linearized" level mode
397	TAB. EINGABEMODUS	LIN. EDIT MODE
401	MODUS ALARMQUIT.	ACK. ALARM MODE
404	ZÄHLER T > Tmax	COUNTER: T > Tmax
409	BETRIEBSSTUNDEN	OPERATING HOURS
413	SIMULATION	SIMULATION MODE
414	SIM. DRUCKWERT	SIM. PRESSURE
419	INHALT HAUPTZEIL	MAIN LINE CONT.
423	ANZ ALTERNIEREND	ALTERNATE DATA
434	DRUCK N. LAGEKOR – Betriebsart "Druck"	CORRECTED PRESS. – "Pressure" measuring mode
	DRUCK N. LAGEKOR – Betriebsart "Füllstand"	CORRECTED PRESS. – "Level" measuring mode
467	ZÄHLER P < Pmin	COUNTER: P < Pmin
469	MINIMALER DRUCK	MIN. MEAS. PRESS.
471	MAXIMALE TEMP.	MAX. MEAS. TEMP.
472	ZÄHLER T < Tmin	COUNTER: T < Tmin
474	MINIMALE TEMP.	MIN. MEAS. TEMP.
476	SIM. FEHLERNR.	SIM. ERROR NO.
480	ALARMHALTEZEIT	ALARM DISPL. TIME
482	TYP ANSCHLUSS	PROC. CONN. TYPE
484	LRL SENSOR	PRESS.SENS LOLIM
485	URL SENSOR	PRESS.SENS HILIM
487	SENSOR HW REV.	SENSOR H/WARE REV.
488	PCB COUNT T>Tmax	PCB COUNT: T>Tmax
490	MAX. EL. TEMP.	PCB MAX. TEMP.
492	PCB COUNT T<Tmin	PCB COUNT: T < Tmin
494	PCB MIN. TEMP.	PCB MIN. TEMP.
500	ALARM QUITTIEREN	ACK. ALARM
549	MESSTABELLE (Anzeige)	MEASURING TABLE (display)
549	TABELLEEDITOR, ZEILEN-NR (Werte eingeben)	EDITOR TABLE, LINE-NUMB (enter values)
550	TABELLEEDITOR, X-WERT (Werte eingeben)	EDITOR TABLE, X-VAL. (enter values)
551	TABELLEEDITOR, Y-WERT (Werte eingeben)	EDITOR TABLE, Y-VAL. (enter values)
563	LAGESOLLWERT	POS. INPUT VALUE
564	LETZTE DIAG. CODE	LAST DIAG. CODE
570	Pmax ANSCHLUSS	Pmax PROC. CONN.
571	EINH. MASSEFLUSS	MASS FLOW UNIT
581	SENSORMESSTYP	SENSOR MEAS. TYPE
584	SENSOR DRUCK – Betriebsart "Druck"	SENSOR PRESSURE – "Pressure" measuring mode

Display ID	German parameter name	English parameter name
	SENSOR DRUCK – Betriebsart "Füllstand"	SENSOR PRESSURE – "Level" measuring mode
591	MINIMALE SPANNE	MINIMUM SPAN
595	AUSWAHL ALARME	SELECT ALARMTYPE
600	AUSWAHL ALARME	SELECT ALARMTYPE
603	RESET MELDUNGEN	RESET ALL ALARMS
607	FAKT. BEN. EINH. V – Füllstandtyp "Linear" FAKT. BEN. EINH. V – Füllstandtyp "Druck mit Kennlinie" FAKT. BEN. EINH. V – Füllstandtyp "Höhe mit Kennlinie"	CUST. UNIT FACT. V – "Linear" level mode CUST. UNIT FACT. V – "Pressure linearized" level mode CUST. UNIT FACT. V – "Height linearized" level mode
608	BEN. EINHEIT V – Füllstandtyp "Linear" BEN. EINHEIT V – Füllstandtyp "Druck mit Kennlinie" BEN. EINHEIT V – Füllstandtyp "Höhe mit Kennlinie"	CUSTOMER UNIT V – "Linear" level mode CUSTOMER UNIT V – "Pressure linearized" level mode CUSTOMER UNIT V – "Height linearized" level mode
609	FAKT. BEN. EINH. F	CUST. UNIT. FACT. F
610	BEN. EINHEIT F	CUSTOMER UNIT F
679	MESSWERT – "Druck" MESSWERT – "Füllstand"	MEASURED VALUE – "Pressure" MEASURED VALUE – "Level"
685	LAGEKORREKTUR	POS. ZERO ADJUST
688	FORMAT HAUPTZEIL	MAIN DATA FORMAT
703	FAKT. BEN. EINH. M – Füllstandtyp "Linear" FAKT. BEN. EINH. M – Füllstandtyp "Druck mit Kennlinie" FAKT. BEN. EINH. M – Füllstandtyp "Höhe mit Kennlinie"	CUST. UNIT FACT. M – "Linear" level mode CUST. UNIT FACT. M – "Pressure linearized" level mode CUST. UNIT FACT. M – "Height linearized" level mode
704	BEN. EINHEIT M – Füllstandtyp "Linear" BEN. EINHEIT M – Füllstandtyp "Druck mit Kennlinie" BEN. EINHEIT M – Füllstandtyp "Höhe mit Kennlinie"	CUSTOMER UNIT M – "Linear" level mode CUSTOMER UNIT M – "Pressure linearized" level mode CUSTOMER UNIT M – "Height linearized" level mode
705	FAKT. BEN. EINH. H – Füllstandtyp "Linear" FAKT. BEN. EINH. H – Füllstandtyp "Höhe mit Kennlinie"	CUST. UNIT FACT. H – "Linear" level mode CUST. UNIT FACT. H – "Height linearized" level mode
706	BEN. EINHEIT H – Füllstandtyp "Linear" BEN. EINHEIT H – Füllstandtyp "Höhe mit Kennlinie"	CUSTOMER UNIT H – "Linear" level mode CUSTOMER UNIT H – "Height linearized" level mode
708	EINHEIT HÖHE – Füllstandtyp "Linear" EINHEIT HÖHE – Füllstandtyp "Höhe mit Kennlinie"	HEIGHT UNIT – "Linear" level mode HEIGHT UNIT – "Height linearized" level mode
709	EINHEIT MASSE – Füllstandtyp "Linear" EINHEIT MASSE – Füllstandtyp "Druck mit Kennlinie" EINHEIT MASSE – Füllstandtyp "Höhe mit Kennlinie"	MASS UNIT – "Linear" level mode MASS UNIT – "Pressure linearized" level mode MASS UNIT – "Height linearized" level mode
710	DRUCK LEER – Füllstandtyp "Linear" DRUCK LEER – Füllstandtyp "Höhe mit Kennlinie"	EMPTY PRESSURE – "Linear" level mode EMPTY PRESSURE – "Height linearized" level mode
711	DRUCK VOLL – Füllstandtyp "Linear" DRUCK VOLL – Füllstandtyp "Höhe mit Kennlinie"	FULL PRESSURE – "Linear" level mode FULL PRESSURE – "Height linearized" level mode
712	FÜLLHÖHE MAX.	LEVEL MAX.
713	TANKINHALT MAX.	TANK CONTENT MAX.
714	SIM. FÜLL. V. LIN.	SIM. LEVEL
715	SIM. TANKINHALT	SIM. TANK CONT.
717	MESSTABELLE (Auswahl)	MEASURING TABLE (selection)
718	FÜLLSTANDTYP	LEVEL MODE
755	FÜLLHÖHE MIN.	LEVEL MIN.
759	TANKINHALT MIN.	TANK CONTENT MIN.
761	HYDR. DRUCK MAX.	HYDR. PRESS MAX.
770	TABELLEEDITOR (Eingabe fortsetzen)	EDITOR TABLE (continue entries)
775	HYDR. DRUCK MIN.	HYDR. PRESS MIN.
804	MESSGR. LINEAR	LIN. MEASURAND
805	MESSGR. LINEARIS.	LINd. MEASURAND
806	MESSGR. KOMB.	COMB. MEASURAND
808	TABELLENAUSWAHL	TABLE SELECTION
809	TABELLEEDITOR (Tabelle auswählen)	EDITOR TABLE (select table)
810	DICHTE ABGLEICH – Füllstandtyp "Linear" DICHTE ABGLEICH – Füllstandtyp "Höhe mit Kennlinie"	ADJUST DENSITY – "Linear" level mode ADJUST DENSITY – "Height linearized" level mode
811	DICHTE PROZESS	PROCESS DENSITY
812	EINHEIT DICHTE – Füllstandtyp "Linear" EINHEIT DICHTE – Füllstandtyp "Höhe mit Kennlinie"	DENSITY UNIT – "Linear" level mode DENSITY UNIT – "Height linearized" level mode
813	100% PUNKT – Füllstandtyp "Linear" 100% PUNKT – Füllstandtyp "Höhe mit Kennlinie"	100 % POINT – "Linear" level mode 100 % POINT – "Height linearized" level mode
814	NULLPUNKTVERSATZ – Füllstandtyp "Linear" NULLPUNKTVERSATZ – Füllstandtyp "Höhe mit Kennlinie"	ZERO POSITION – "Linear" level mode ZERO POSITION – "Height linearized" level mode
815	TANKBESCHREIBUNG	TANK DESCRIPTION
831	HistoROM VORHND.	HistoROM AVAIL.
832	HistoROM FUNKT.	HistoROM CONTROL
858	TANKVOLUMEN	TANK VOLUME
859	TANKHÖHE	TANK HEIGHT

Display ID	German parameter name	English parameter name
981	AI 3 OUT Value	AI 3 OUT Value
982	AI 2 OUT Value	AI 2 OUT Value
983	AI 1 OUT Value	AI 1 OUT Value
984	DEVICE ADDRESS	DEVICE ADDRESS
985	DD REVISION	DD REVISION
986	DEVICE REVISION	DEVICE REVISION
987	DEVICE ID	DEVICE ID

Index

A		
Assignment of Transducer Blocks (CHANNEL)	30	
B		
Block configuration, delivery status	29	
C		
Cable specification	18	
CHANNEL-Parameter	30	
Current consumption	18	
D		
Deltapilot S block model	27	
Device addressing	27	
Device identification	27	
Differential pressure measurement, Quick Setup menu	56	
Display	20	
E		
Electrical connection	17	
Error messages	71	
F		
Factory setting	44	
FOUNDATION Fieldbus system architecture	25	
G		
Grounding procedure	18	
H		
Hazardous area	7	
HistoROM/M-DAT	40	
I		
Incoming acceptance	10	
Index tables	32	
Intended use	6	
L		
Level measurement	52	
Level measurement, Quick Setup menu	54	
Locking	43	
M		
Menu structure	37	
Methods	36	
N		
Nameplate	8	
Number of devices	26	
O		
Onsite display	20	
Operating elements, function	23–24	
Operating elements, position	22	
Operating keys, onsite, function	23–24	
Operating keys, position	22	
Operational safety	6	
Overvoltage protection	19	
P		
Pipe mounting	13	
Position adjustment, FieldCare	51	
Position adjustment, onsite	23	
Position adjustment, onsite display, FieldCare	51	
Product safety	7	
Q		
Quick Setup menu level	54	
Quick Setup menu pressure	56	
R		
Repair	87	
Repair of Ex-certified devices	87	
Reset	44	
Returning devices	87	
Rotating the housing	15	
S		
Safety instructions	6	
Scaling OUT value	58	
Scope of delivery	8	
Selecting the language	49	
Selecting the measuring mode	49	
Separate housing, assembly and mounting	14	
Shielding	18	
Simulation	44	
Software history	88	
Spare parts	87	
Storage	10	
Supply voltage	18	
T		
Troubleshooting	71	
U		
Unlocking	43	
W		
Wall mounting	13	
Warnings	71	
Workplace safety	6	



71556699

www.addresses.endress.com
