

Installation Instructions

Replacing the electronic parts, non Ex/Zone 2/Div.2/Ex db/ Zone1/Div.1

Proline 10



Replacement of electronic parts, non-Ex, Zone 2/ Div.2/Ex db/Zone1/Div.1

Proline 10

Table of contents

1	Overview of spare part set	4
2	Intended use	5
3	Personnel authorized to carry out repairs	6
4	Safety instructions	6
5	Symbols	8
6	Tools list	8
7	Transmitter housing, non-Ex/Zone 2/Div. 2	9
8	Promag 10	16
9	Promass 10	19
10	Reassembly	21
11	Final steps	28
12	Disposal	28

1 Overview of spare part set

The Installation Instructions apply to the following spare parts:

Order number	Original spare part set	Contents
XPD0060	ISEM set, standard, HART Promag 10, nEx	1 × ISEM Sensor electronics module
XPD0061	ISEM set, standard, Modbus Promag 10, nEx	1 × ISEM Sensor electronics module
XPD0062	ISEM set, extended, HART Promag 10, nEx/Z2/Exd	1 × ISEM Sensor electronics module
XPD0063	ISEM set, extended, Modbus Promag 10, nEx/Z2/Exd	1 × ISEM Sensor electronics module
XPD0098	ISEM set, standard, IO-Link Promag 10, nEx	1 × ISEM Sensor electronics module
XPD0099	ISEM set, extended, IO-Link Promag 10, nEx	1 × ISEM Sensor electronics module
XPD0066	ISEM set, DN 08 to 80 HART, Promass 10, nEx/ Z2	1 × ISEM Sensor electronics module
XPD0067	ISEM, DN 08 to 80 Modbus, Promass 10, nEx/ Z2	1 × ISEM Sensor electronics module
XPD0068	ISEM set, DN 08 to 15 HART, Promass 10, Exd	1 × ISEM Sensor electronics module
XPD0069	ISEM set, DN 08 to 15 Modbus, Promass 10, Exd	1 × ISEM Sensor electronics module
XPD0070	ISEM set, DN 25 to 80 HART, Promass 10, Exd	1 × ISEM Sensor electronics module
XPD0071	ISEM set, DN 25 to 80 Modbus, Promass 10, Exd	1 × ISEM Sensor electronics module
XPD0100	ISEM set, DN 08 to 80 IO-Link, Promass 10, nEx	1 × ISEM Sensor electronics module
XPD0076	Electronics module set HART, 24VDC, nEx, polycarbonate, 10	1 × module holder with power supply module, I/O module
XPD0077	Electronics module set HART, 100-230VAC, nEx, polycarbonate, 10	1 × module holder with power supply module, I/O module
XPD0078	Electronics module set Modbus, 24VDC, nEx, polycarbonate, 10	1 × module holder with power supply module, I/O module
XPD0079	Electronics module set Modbus, 100-230VAC, nEx, polycarbonate, 10	1 × module holder with power supply module, I/O module
XPD0080	Electronics module set HART, 24VDC, nEx, aluminum, 10	1 × module holder with power supply module, I/O module
XPD0081	Electronics module set HART, 100-230VAC, nEx, aluminum, 10	1 × module holder with power supply module, I/O module

Order number	Original spare part set	Contents
XPD0082	Electronics module set HART, 100-230VAC/24VDC nEx, aluminum, 10	1 × module holder with power supply module, I/O module
XPD0083	Electronics module set HART, 100-230VAC/24VDC, Exd/Z2, aluminum, 10	1 × module holder with power supply module, I/O module
XPD0084	Electronics module set Modbus, 100-230VAC/24VDC nEx/Exd/Z2, aluminum, 10	1 × module holder with power supply module, I/O module
XPD0096	Electronics module set IO-Link, nEx, polycarbonate, 10	1 × module holder with I/O module
XPD0097	Electronics module set IO-Link, nEx, aluminum, 10	1 × module holder with × I/O module
71505739	S+T-DAT set, Promag 10 non-Ex, Exd/Z2	1 × DAT sensor
71505741	S+T-DAT set, Promass 10 non-Ex, Exd/Z2	1 × DAT sensor
71505745	Terminal set, Proline 10	1 × 2-pin plug-in terminal 1 × 6-pin plug-in terminal
71631284	ISEM cable set, Promag 10, nEx/Exd/Z2	1 × ribbon cable
71631287	ISEM cable set, Promass 10, nEx/Exd/Z2	1 × ribbon cable



- The order number of the spare part set (on the product label on the package) can differ from the production number (on the label directly on the spare part)!
- You can find the order number of the relevant spare part set by entering the production number of the spare part in the spare part search tool.
- We recommend that you keep the Installation Instructions and packaging together at all times.

2 Intended use

- A defective unit can only be replaced with a functioning unit of the same type.
- Use only original parts from Endress+Hauser.
- In the W@M Device Viewer, check if the spare part is suitable for the existing device.



In some devices, an overview of spare parts is provided inside the device. If the spare part is listed in the overview, it is not necessary to check the Device Viewer.

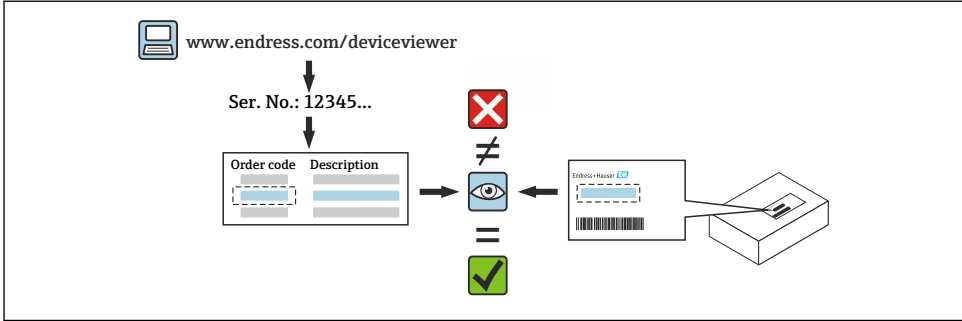

3 Personnel authorized to carry out repairs

Authorization to carry out repairs depends on the measuring device's approval type. The table below shows the authorized group of people in each case.

i Whoever carries out the repairs has full responsibility to ensure that work is carried out safely and to the required quality standard. He/she must also guarantee the safety of the device following repair.

Measuring instrument approval	Personnel authorized to perform repairs ¹⁾
Without approval	1, 2, 3
With approval (e.g. IECEx)	2, 3
For custody transfer	4

- 1) 1 = Qualified specialist on customer side, 2 = Service technician authorized by Endress+Hauser ,
 3 = Endress+Hauser (return measuring instrument to manufacturer)
 4 = Check with local approval center if installation/modification must be performed under supervision.

4 Safety instructions

- Check whether the spare part matches the identification labeling on the measuring device, as described on the cover page.
- The spare part set and the Installation Instructions are used to replace a defective unit with a functioning unit of the same type.
 Only use original parts from Endress+Hauser.
- Comply with national regulations regarding mounting, electrical installation, commissioning, maintenance and repair.

- The following requirements must be met with regard to specialized technical staff for the mounting, electrical installation, commissioning, maintenance and repair of the measuring devices:
 - Specialized technical staff must be trained in instrument safety.
 - They must be familiar with the individual operating conditions of the devices.
 - In the case of Ex-certified measuring devices, they must also be trained in explosion protection.
- The measuring device is energized! Risk of fatal injury from electric shock. Open the measuring device only when the device is de-energized.
- For measuring devices intended for use in hazardous locations, please observe the guidelines in the Ex documentation (XA).
- For measuring devices in safety-related applications in accordance with IEC 61508 or IEC 61511: following repair, re-commission the device in accordance with the Operating Instructions. Document the repair.
- Before removing the device: set the process to a safe state and purge the pipe of dangerous process substances.
- Danger of burns due to heated surfaces! Before commencing work: allow the system and measuring device to cool down to a touchable temperature.
- In the case of devices in custody transfer, the custody transfer status no longer applies once the seal has been removed.
- The Operating Instructions for the device must be followed.
- Risk of damaging the electronic components! Ensure you have a working environment protected from electrostatic discharge.
- After removing the electronics compartment cover: risk of electrical shock due to missing touch protection!
Turn the measuring device off before removing internal covers.
- Modifications to the measuring device are not permitted.
- Only open the housing for a brief period. Avoid foreign objects, moisture or dirt entering the housing.
- Replace defective seals only with original seals from Endress+Hauser.
- If threads are defective the measuring device must be repaired.
- Threads (e.g. of the electronics compartment cover and connection compartment cover) must be lubricated if an abrasion-proof dry lubricant is not available. Use acid-free, non-hardening lubricant.
- If, during repair work, spacing is reduced or the dielectric strength of the measuring device cannot be guaranteed, perform a test on completion of the work (e.g. high-voltage test in accordance with the manufacturer's instructions).
- Service plug:
 - Do not connect in potentially explosive atmospheres.
 - Only connect to Endress+Hauser service devices.
- Observe the instructions for transporting and returning the device outlined in the Operating Instructions.



Contact Endress+Hauser Service if you have questions: www.addresses.endress.com

5 Symbols

5.1 Safety symbols

DANGER

This symbol alerts you to a dangerous situation. Failure to avoid this situation will result in serious or fatal injury.

WARNING

This symbol alerts you to a potentially dangerous situation. Failure to avoid this situation can result in serious or fatal injury.





CAUTION

This symbol alerts you to a potentially dangerous situation. Failure to avoid this situation can result in minor or medium injury.





NOTICE

This symbol alerts you to a potentially harmful situation. Failure to avoid this situation can result in damage to the product or something in its vicinity.

5.2 Symbols for certain types of information

Symbol	Meaning
	Permitted Procedures, processes or actions that are permitted.
	Forbidden Procedures, processes or actions that are forbidden.
	Tip Indicates additional information.
	Series of steps

6 Tools list

 <p>Allen key 3 mm, 5 mm</p>	 <p>Torx screwdriver T10, T20</p>	 <p>Hexagon key</p>	 <p>Slotted head screwdriver 0.5 x 3.5 mm</p>	<p>Use plastic- compatible grease, such as Klübersynth R 42-111</p>
--	--	--	--	---

7 Transmitter housing, non-Ex/Zone 2/Div. 2

⚠ WARNING

The measuring device is energized!

Risk of fatal injury from electric shock.

- ▶ Open the measuring device only when the device is de-energized.

7.1 Opening the cover of the aluminum transmitter housing

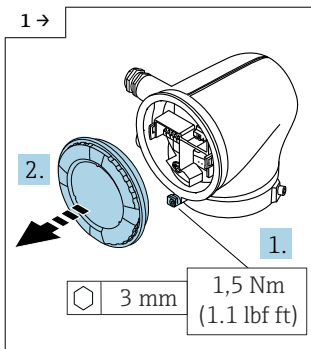

- ▶ Transmitter housing with dummy cover
- ▶ Loosen the screw and open the cover.

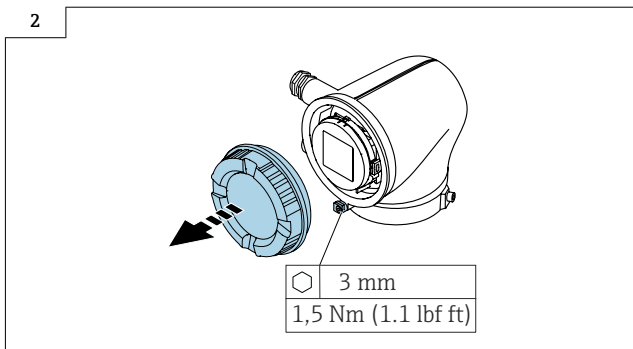

- ▶ Transmitter housing with window cover
- ▶ Loosen the screw and open the cover.

7.2 Opening the cover of the polycarbonate transmitter housing

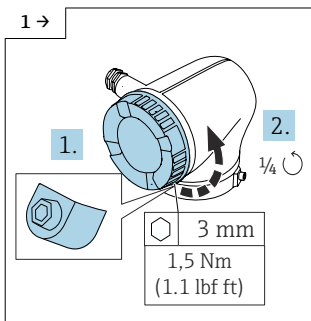

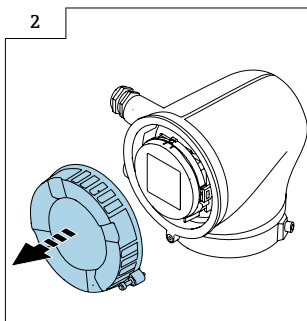

- ▶ Unscrew the screw from the locking mechanism until the cover can be turned. Then turn the cover counterclockwise by a 1/4 turn.



- ▶ Remove the cover.

7.3 Replacing the terminals, module holder

Proceed as described in Section 7.1 →  9 or Section 7.2 →  9 and as illustrated in the graphics below.

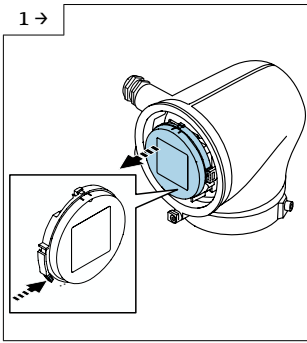

- 1 →
- ▶ **Transmitter housing with display module**
 - ▶ Press the tab and remove the display module from the transmitter.

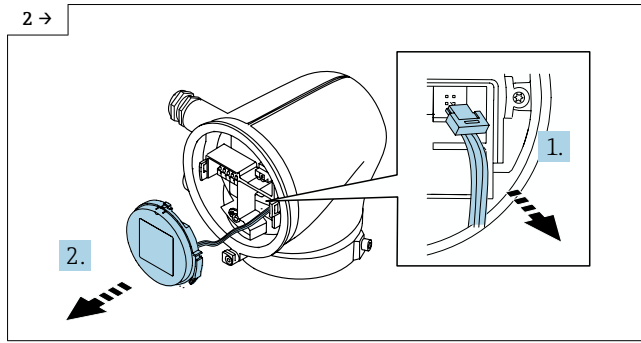

- 2 →
- ▶ **Transmitter housing with display module**
 - ▶ Push the tab above the plug upwards, pull out the plug and remove the display module.

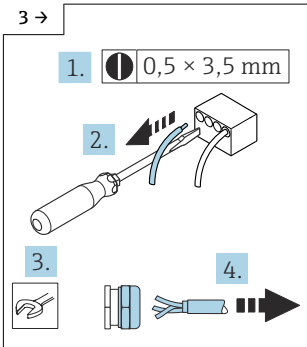

- 3 →
- ▶ Release the connecting cable, open the cable gland and remove the cable.

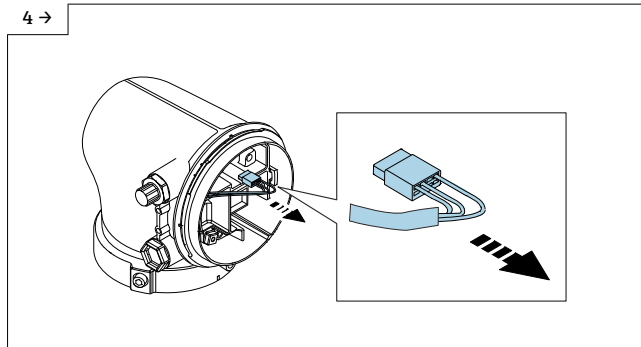

- 4 →
- ▶ **Promag H:** Disconnect the connection to the electronics module.

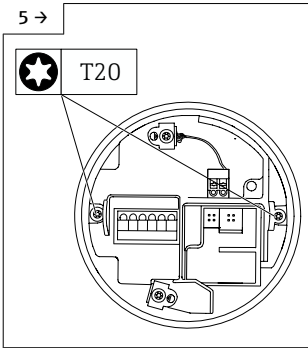

- ▶ **Aluminum transmitter housing**
- ▶ Loosen 2 Torx screws of the electronics module.

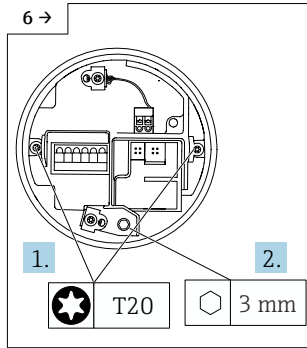

- ▶ **Polycarbonate transmitter housing**
- ▶ Loosen 2 Torx screws of the electronics module, loosen the grounding screw.

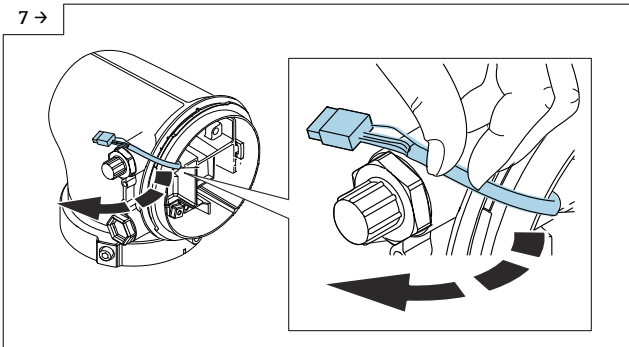

- ▶ **Promag H:** Guide the cable with the connection to the recess on the electronics module and hold it there.

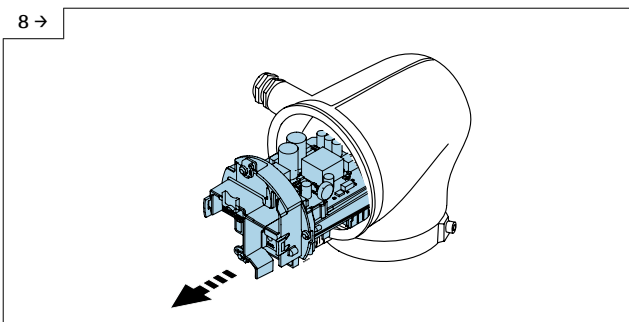

- ▶ Pull the electronics module out of the transmitter housing as far as possible.

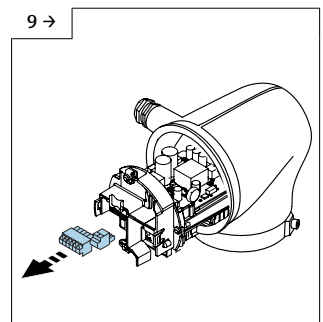

- ▶ Remove and replace the terminals.

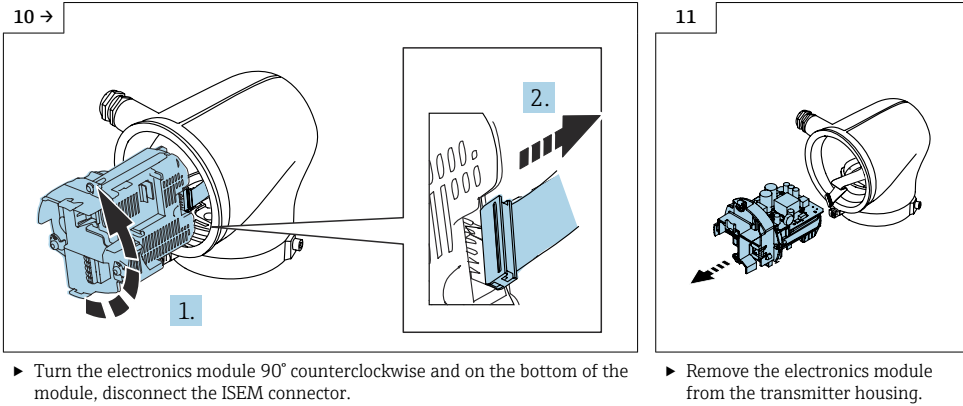

7.4 Replacing the ribbon cable

▶ Procedure

↳ as described in Section 7.3 → 10 and as illustrated in the diagrams below.

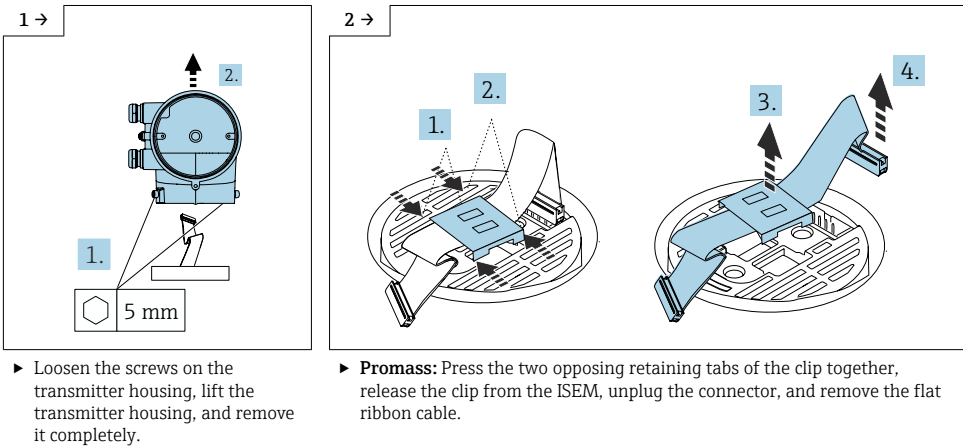

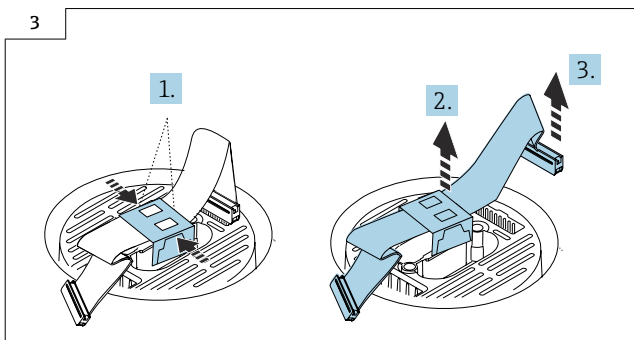

- **Promag:** Press the opposing retaining tabs of the clip together, release the clip from the ISEM, unplug the connector, and remove the flat ribbon cable.

7.5 Opening the aluminum transmitter housing, Ex db/Zone1/Div. 1, replacing the terminals, module holder

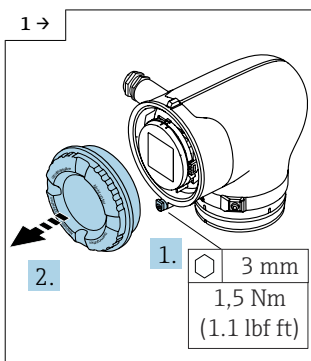

- Loosen the screws and open the cover.

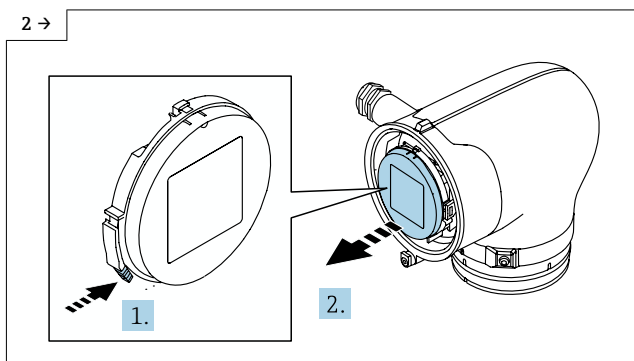

- Press the tab and remove the display module from the transmitter.

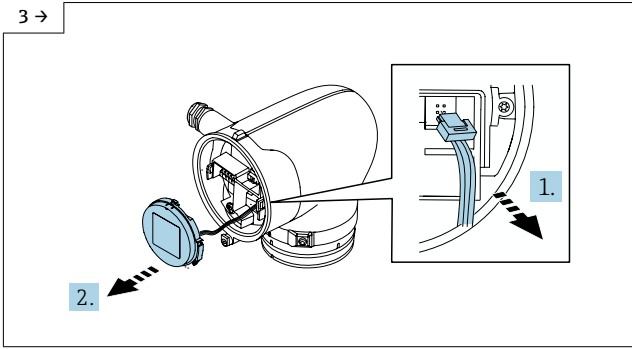

- ▶ Push up the tab above the plug, disconnect the plug and remove the display module.

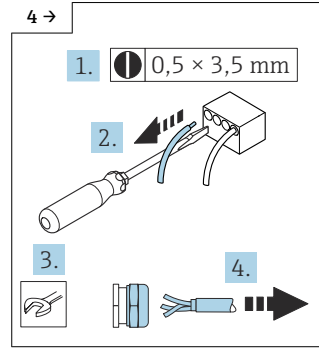

- ▶ Release the connecting cable, open the cable gland and remove the cable.

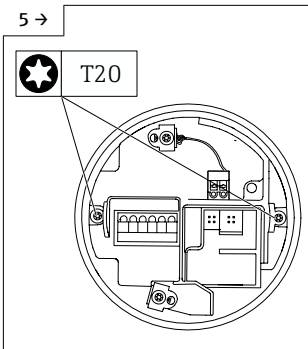

- ▶ Loosen the Torx screws of the electronics module.

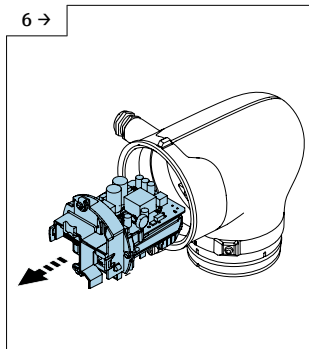

- ▶ Pull the electronics module out of the transmitter housing as far as possible.

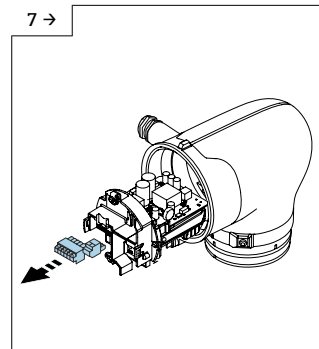

- ▶ Remove and replace the terminals.

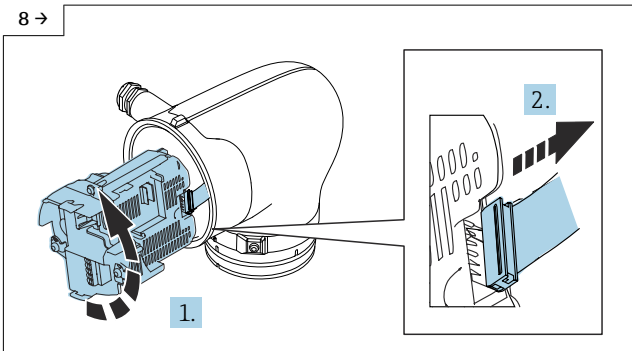

- ▶ Turn the electronics module 90° counterclockwise and on the bottom of the module, disconnect the ISEM connector.

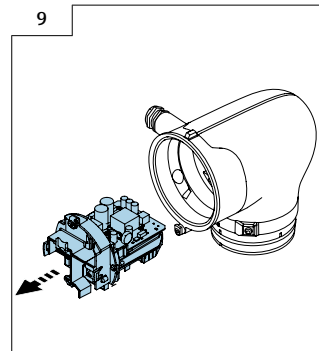

- ▶ Fully remove the electronics module from the transmitter housing.

7.6 Replacing the ribbon cable

► Procedure

↳ as described in Section 7.5 →  13 and as illustrated in the diagrams below.

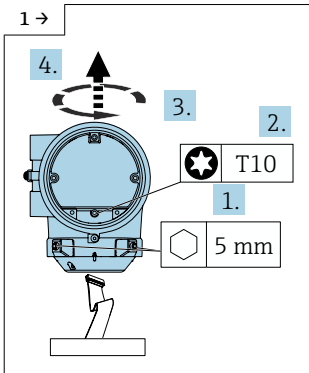

- Slacken the Allen screws on the right and left of the transmitter housing, loosen the twist protection. Turn the transmitter housing and remove it.

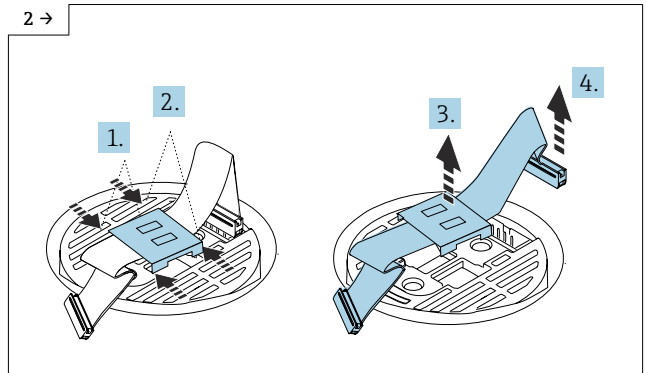

- **Promag:** Press the two opposing retaining tabs of the clip together, release the clip from the ISEM, unplug the connector, and remove the flat ribbon cable.

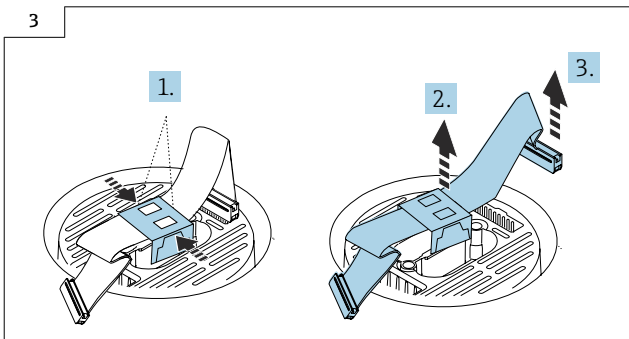

- **Promag:** Press the opposing retaining tabs of the clip together, release the clip from the ISEM, unplug the connector, and remove the flat ribbon cable.

8 Promag 10

8.1 Preparatory steps

Read off the totalizer value and note it down.

 After replacing the S+T-DAT, enter the value you noted down in the device.

8.2 Removing the ISEM, S+T-DAT

► Aluminum/polycarbonate transmitter housing, non-Ex/Zone 2/Div. 2:

- ↳ Proceed as described in Section 7.4 →  12 Fig. 1 and as illustrated in the diagrams below.

► Aluminum transmitter housing, Ex db/Zone1/Div. 1:

- ↳ Proceed as described in Section 7.6 →  15 Fig. 1 and as illustrated in the diagrams below.

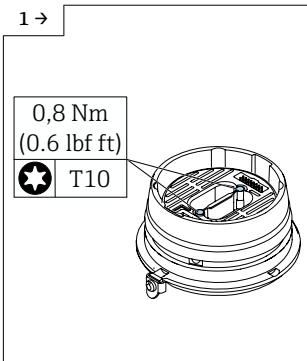

- Loosen the Torx screws of the ISEM.

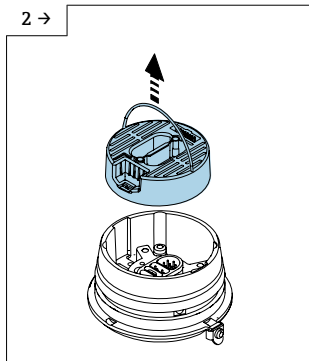

- Remove the ISEM from the interface.

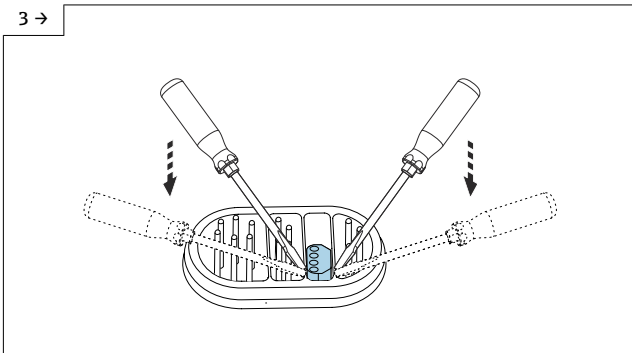

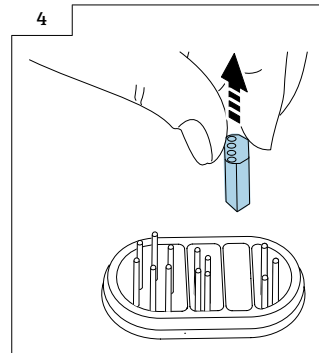

- Carefully pry up the S+T-DAT using two screwdrivers.



- Remove the S+T-DAT from the interface.

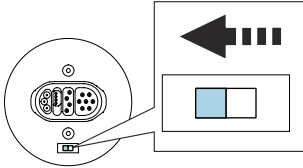
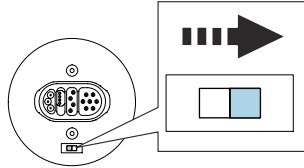

8.3 Preparing to install ISEM for transmitter, compact version

8.3.1 "Measurement isolated from ground" option disabled or enabled (extended transmitter)

"Measurement isolated from ground" option disabled (extended transmitter)	"Measurement isolated from ground" option enabled (extended transmitter)
<p> Faulty measurement performance due to incorrect switch position of the grounding switch on the extended transmitter Check that the grounding switch is in the correct position and correct if necessary!</p>	<p> Damage to the measuring instrument due to incorrect switch position of the grounding switch on the extended transmitter Check that the grounding switch is in the correct position and correct if necessary!</p>
	

8.4 Preparing to install ISEM for transmitter, remote version

8.4.1 "Measurement isolated from ground" option disabled or enabled (extended transmitter)

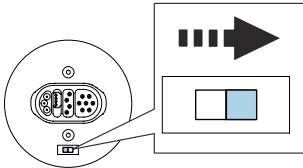
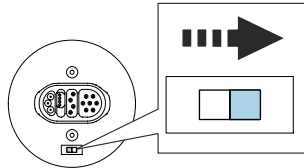
"Measurement isolated from ground" option disabled (extended transmitter)	"Measurement isolated from ground" option enabled (extended transmitter)
<p> Faulty measurement performance due to incorrect switch position of the grounding switch on the extended transmitter Check that the grounding switch is in the correct position and correct if necessary!</p>	<p> Damage to the measuring instrument due to incorrect switch position of the grounding switch on the extended transmitter Check that the grounding switch is in the correct position and correct if necessary!</p>
	

8.5 Installing the S+T-DAT, ISEM

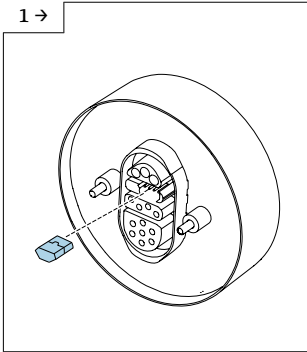

- ▶ Plug the new S+T-DAT into the ISEM. Pay attention to pin diagram!

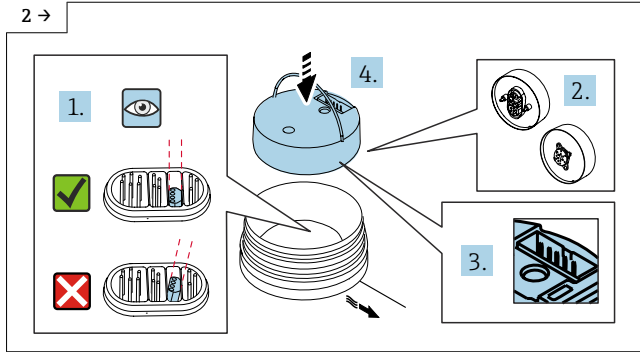

- ▶ Before inserting the new ISEM, check that the new S+T-DAT is straight to avoid any damage to the pins.

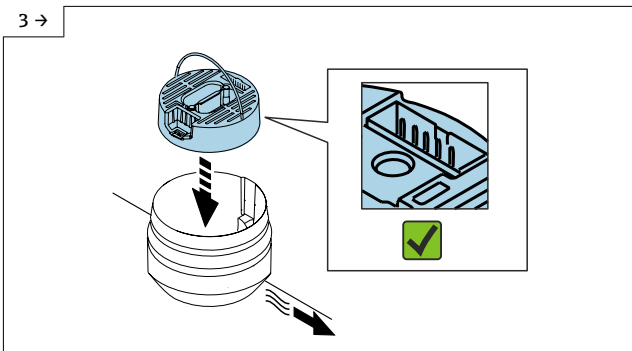

- ▶ Align and position the ISEM in the sensor interface as shown in the graphic. Pay attention to pin diagram!

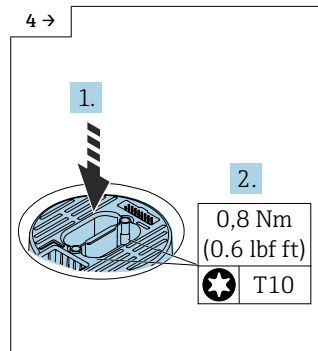

- ▶ Carefully press down the ISEM, tighten the screws as per the torque.

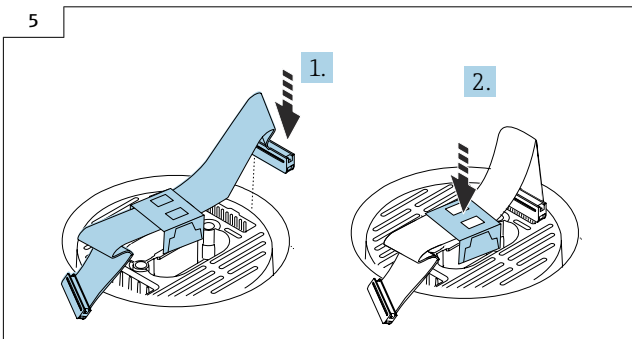



- ▶ Insert the flat ribbon cable connector and secure the flat ribbon cable by fastening the clip to the ISEM.

9 Promass 10

9.1 Preparatory steps

Read off the totalizer value and note it down.

 Read off the totalizer value and note it down.

 After replacing the S+T-DAT, enter the value you noted down in the device.

9.2 Removing the ISEM S+T-DAT

▶ Aluminum/polycarbonate transmitter housing, non-Ex/Zone 2/Div. 2:

↳ Proceed as described in Section 7.4 →  12 Fig. 1 and as illustrated in the diagrams below.

▶ Aluminum transmitter housing, Ex db/Zone 1/Div. 1:

↳ Proceed as described in Section 7.6 →  15 Fig. 1 and as illustrated in the diagrams below.

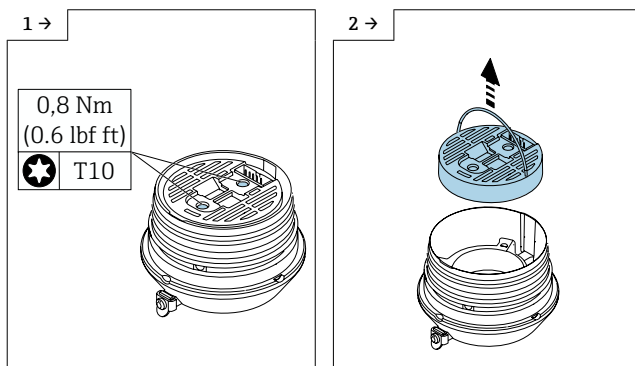

▶ Loosen the Torx screws of the ISEM.

▶ Remove the ISEM from the interface.

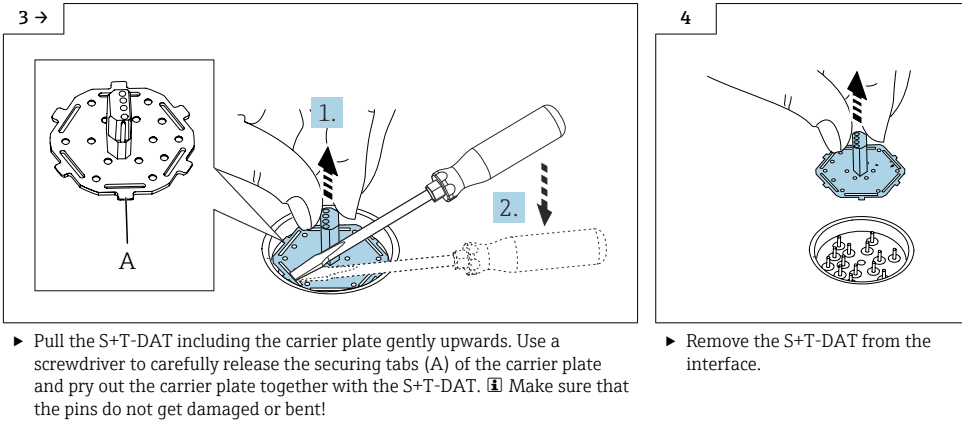

9.3 Installing the S+T-DAT, ISEM

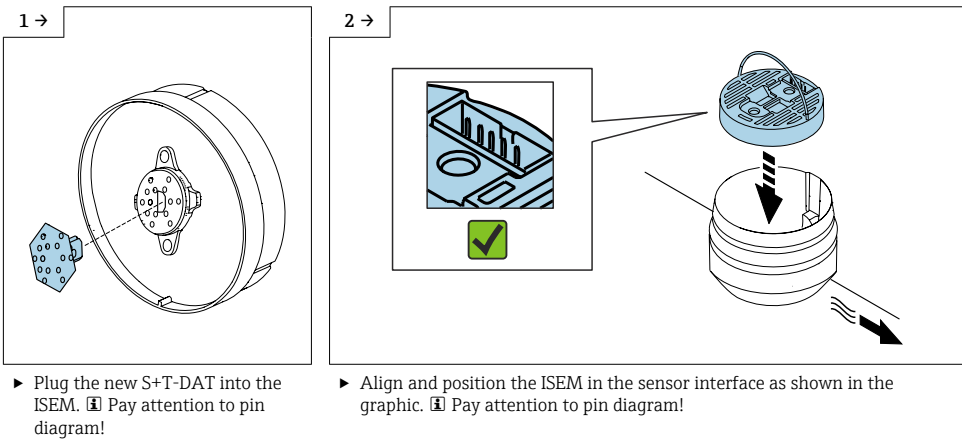

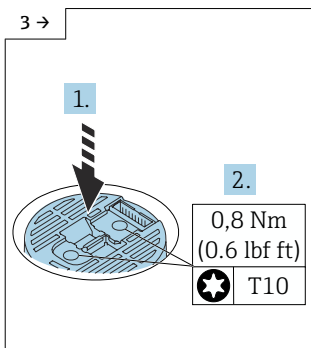

- ▶ Carefully press down the ISEM, tighten the screws as per the torque.

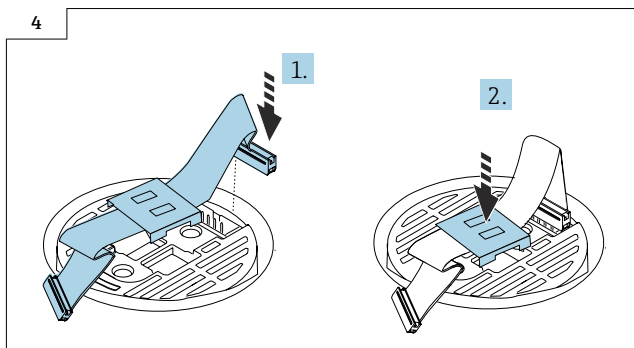

- ▶ Insert the flat ribbon cable connector and secure the flat ribbon cable by fastening the clip to the ISEM.

10 Reassembly

10.1 Installing the transmitter housing, non-Ex/Zone 2/Div. 2

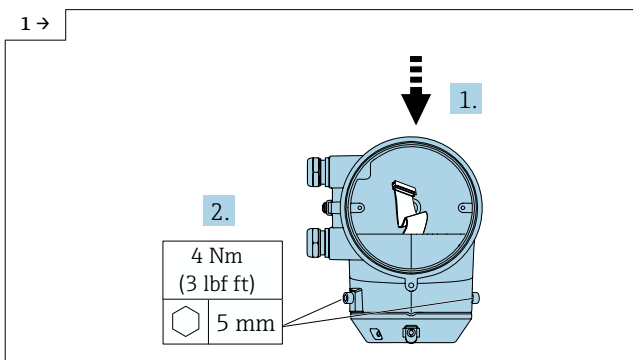

- ▶ Fit the new transmitter housing; guide the ribbon cable through the neck of the housing when doing so. Tighten the screws on the transmitter housing.

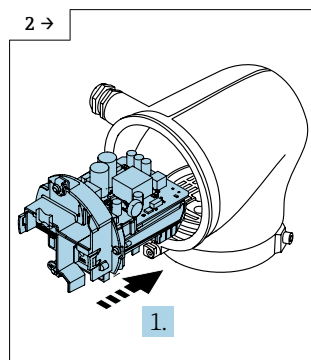

- ▶ Position the electronics module in front of the transmitter housing.

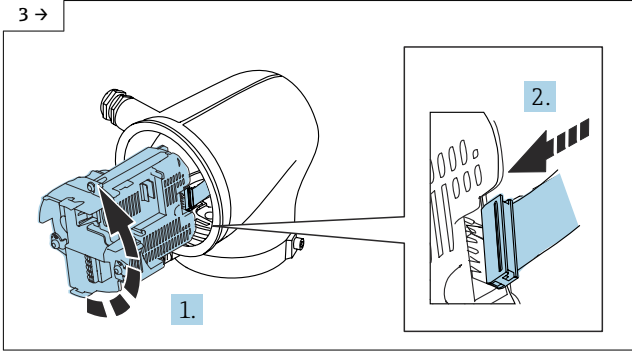

- ▶ Turn the electronics module 90° counterclockwise and on the bottom of the module, insert the ISEM connector.

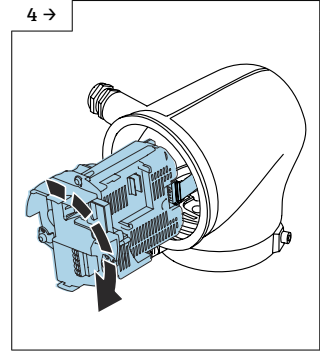

- ▶ Turn the electronics module back 90° clockwise and carefully slide it into the transmitter.

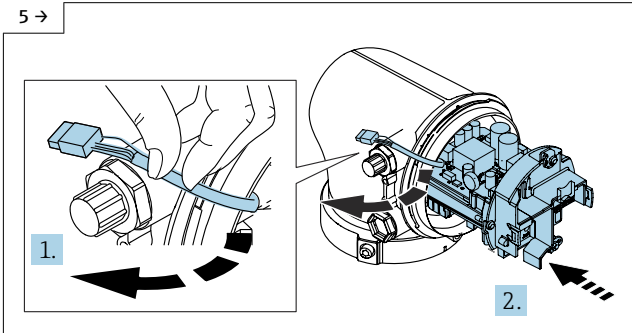

- ▶ **Promag H:** Guide the cable with the connection to the recess of the electronics module and hold it. Carefully insert the electronics module.

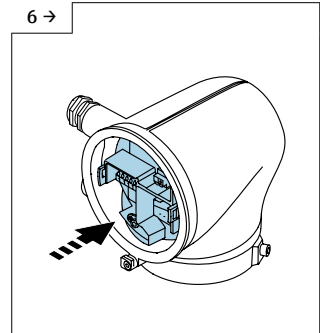

- ▶ Slide the electronics module into the transmitter entirely.

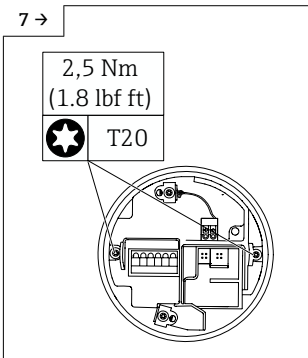

- ▶ **Aluminum transmitter housing**
- ▶ Tighten the 2 Torx screws.

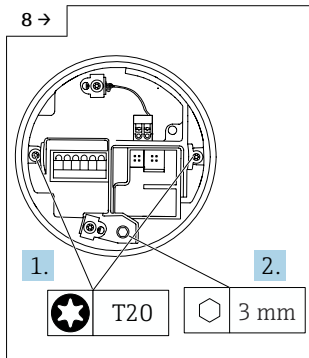

- ▶ **Polycarbonate transmitter housing**
- ▶ Tighten the 2 Torx screws and tighten the earthing screw.

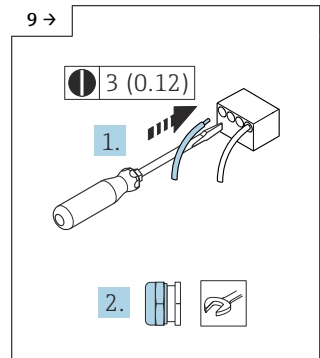

- ▶ Connect the cable as per the terminal assignment in the Operating Instructions. Tighten the cable glands.

10 →

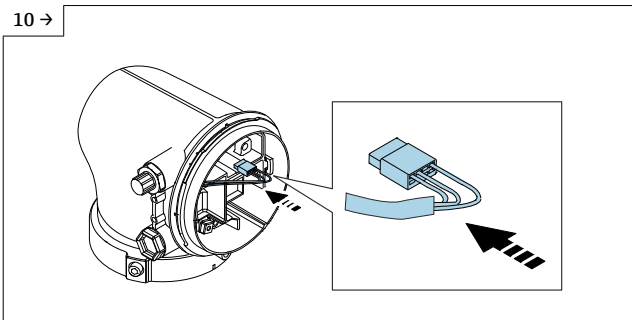

- ▶ **Promag H:** Insert the connection into the electronics module.

11 →

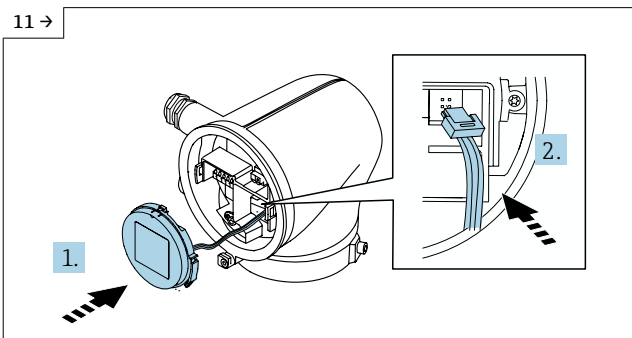

- ▶ **Transmitter housing with display module**
- ▶ Insert the plug, fit the display module on the transmitter housing.

12

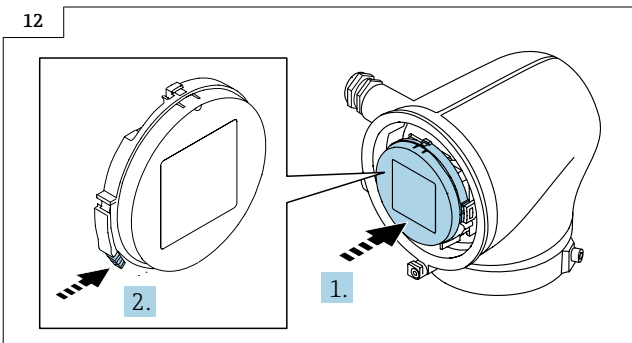

- ▶ **Transmitter with display module**
- ▶ Fit the display module, making sure it engages with a click.

10.2 Closing the cover of the aluminum transmitter housing

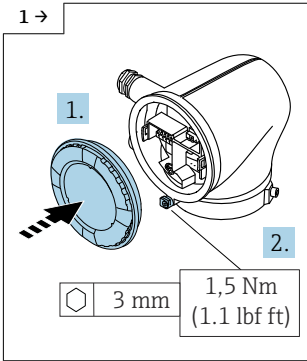

- ▶ Transmitter housing with dummy cover
- ▶ Fit the cover and tighten the screw.

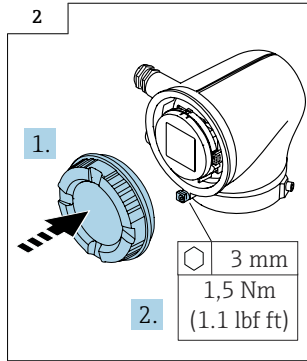

- ▶ Transmitter housing with window cover
- ▶ Fit the cover and tighten the screw.

10.3 Closing the cover of the polycarbonate transmitter housing

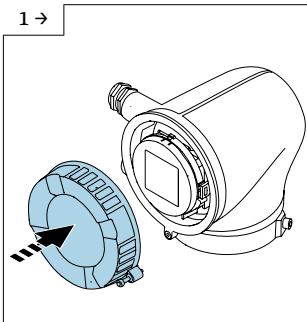

- ▶ Fit the cover.

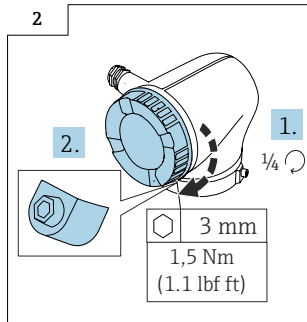

- ▶ Turn the cover by a 1/4 turn in the clockwise direction and tighten the screw.

10.4 Installing the transmitter housing, Ex db, Zone 1, Div. 1

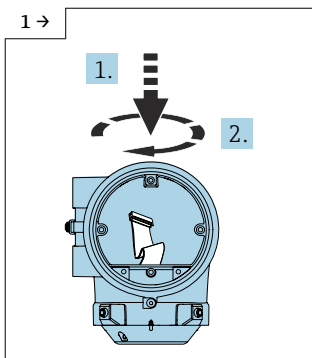

- Fit the transmitter housing; guide the ribbon cable through the neck of the housing when doing so. Turn the transmitter housing.

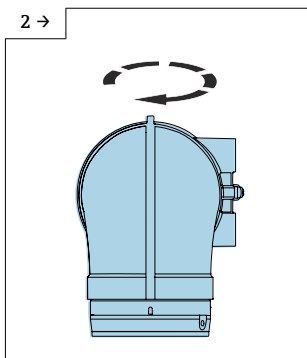

- Turn the transmitter housing until the thread reaches the end stop.

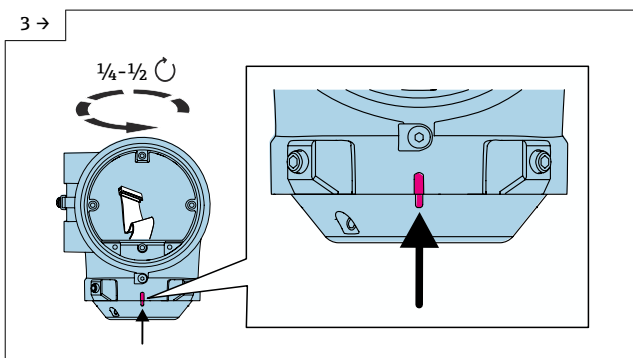

- Turn back the transmitter housing 1/2 a turn until the two markings are aligned above one another.

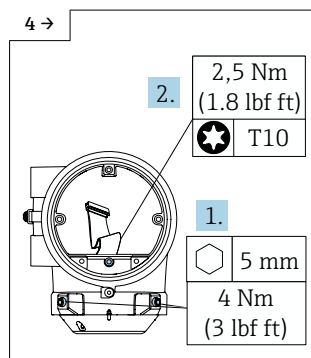

- Tighten the screws on the transmitter housing and tighten the twist protection.

5 →

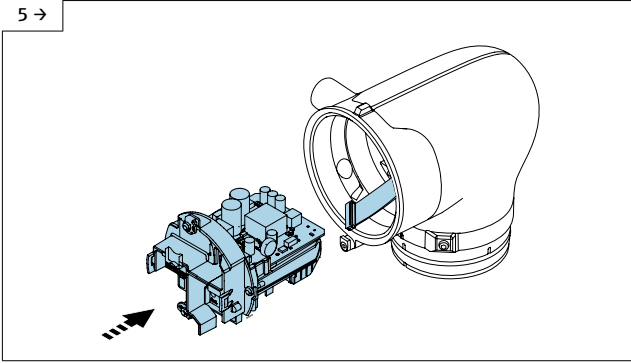

- ▶ Position the electronics module in front of the transmitter housing.

6 →

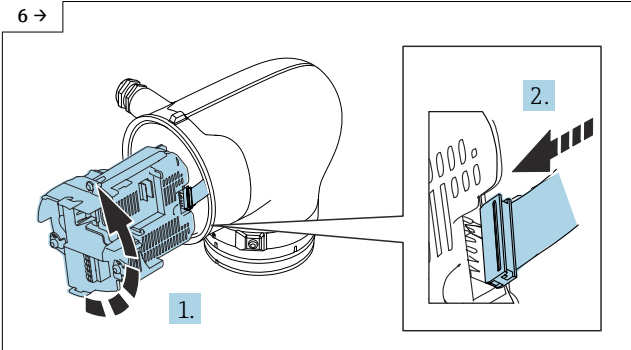

- ▶ Turn the electronics module 90° counterclockwise and on the bottom of the module, insert the ISEM connector.

7 →

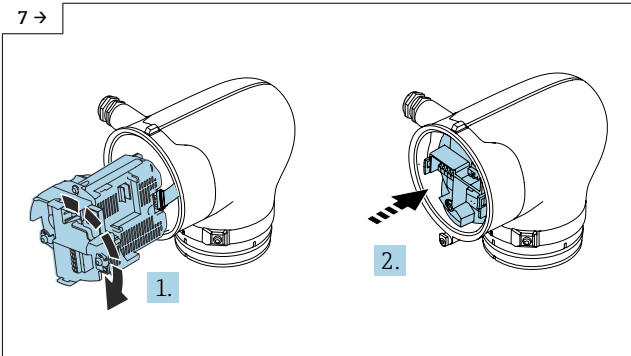

- ▶ Turn the electronics module back 90° clockwise and carefully slide it into the transmitter.

8 →

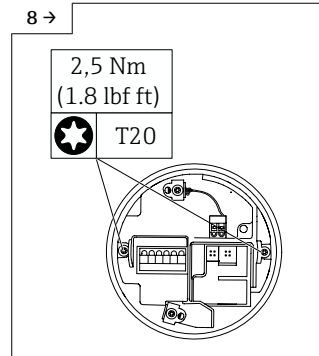

- ▶ Tighten the Torx screws.

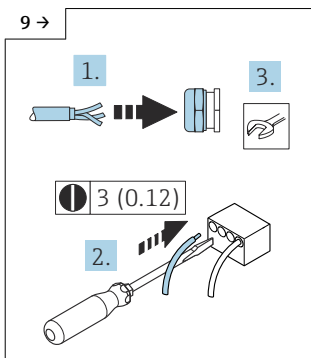

- ▶ Connect the cable as per the terminal assignment in the Operating Instructions. Tighten the cable glands.

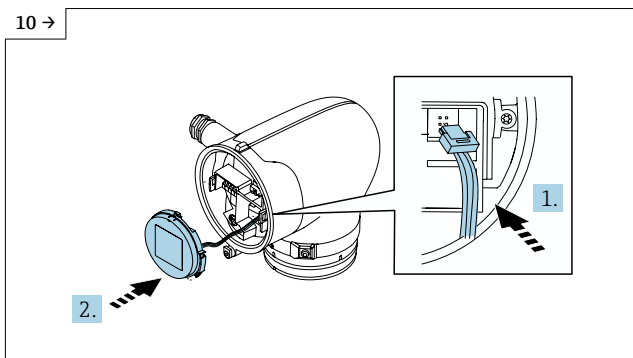

- ▶ Insert the plug, fit the display module.

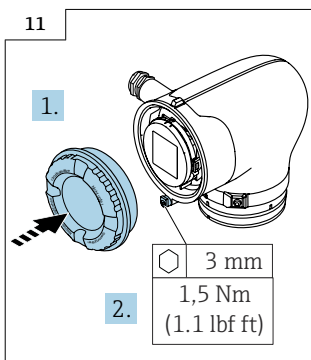

- ▶ Close the cover and tighten the screw.

11 Final steps

11.1 Final steps after replacing the electronics module

NOTICE

Applies for XPD0083- or XPD0084:

For input, output

- ▶ **Option C**
- ▶ 4-20mA HART, pulse/frequency/switch output Ex-i
- ▶ **Option U**
- ▶ Modbus RS485, 4-20mA Ex-i
- ▶ Affix the Exi adhesive label supplied (see graphic 1 below) at the same position on the new electronics module.

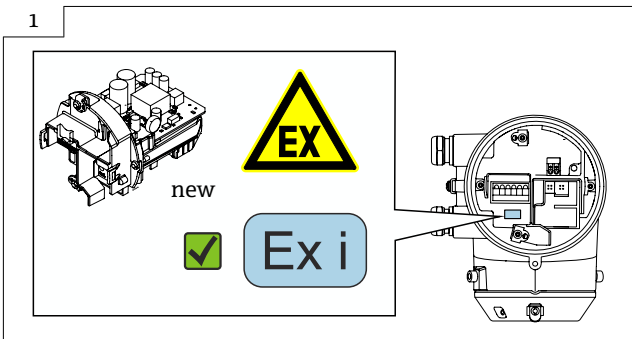

- ▶ Affixing the Exi adhesive label on the new electronics module.

11.2 General final steps

i Once the steps indicated below are performed, the device is restarted. The connection must be re-established via the SmartBlue app.

Totalizer

- ▶ Reset the totalizer.

12 Disposal

WEEE If required by the Directive 2012/19/EU on waste electrical and electronic equipment (WEEE), the product is marked with the depicted symbol in order to minimize the disposal of WEEE as unsorted municipal waste. Do not dispose of products bearing this marking as unsorted municipal waste. Instead, return them to the manufacturer for disposal under the applicable conditions.

Austausch Elektronikteile, Ex-frei, Zone 2/Div.2/Ex db/ Zone1/Div.1

Proline 10

Inhaltsverzeichnis

1	Übersicht Ersatzteilset	30
2	Bestimmungsgemäße Verwendung	31
3	Reparaturberechtigte Personen	32
4	Sicherheitshinweise	32
5	Verwendete Symbole	33
6	Werkzeugliste	34
7	Messumformergehäuse Ex-frei/Zone 2/Div. 2	34
8	Promag 10	42
9	Promass 10	45
10	Zusammenbau	47
11	Abschliessende Arbeiten	53
12	Entsorgung	53

1 Übersicht Ersatzteilset

Die Einbauanleitung ist für folgende Ersatzteile gültig:

Bestellnummer	Set Original Ersatzteil	Inhalt
XPD0060	Set ISEM, Standard, HART Promag 10, nEx	1 × ISEM Sensorelektronikmodul
XPD0061	Set ISEM, Standard, Modbus Promag 10, nEx	1 × ISEM Sensorelektronikmodul
XPD0062	Set ISEM, erweitert, HART Promag 10, nEx/Z2/Exd	1 × ISEM Sensorelektronikmodul
XPD0063	Set ISEM, erweitert, Modbus Promag 10, nEx/Z2/Exd	1 × ISEM Sensorelektronikmodul
XPD0098	Set ISEM, Standard, IO-Link Promag 10, nEx	1 × ISEM Sensorelektronikmodul
XPD0099	Set ISEM, erweitert, IO-Link Promag 10, nEx	1 × ISEM Sensorelektronikmodul
XPD0066	Set ISEM, DN 08 ... 80 HART, Promass 10, nEx/ Z2	1 × ISEM Sensorelektronikmodul
XPD0067	ISEM, DN 08 ... 80 Modbus, Promass 10, nEx/ Z2	1 × ISEM Sensorelektronikmodul
XPD0068	Set ISEM, DN 08 ... 15 HART, Promass 10, Exd	1 × ISEM Sensorelektronikmodul
XPD0069	Set ISEM, DN 08 ... 15 Modbus, Promass 10, Exd	1 × ISEM Sensorelektronikmodul
XPD0070	Set ISEM, DN 25 ... 80 HART, Promass 10, Exd	1 × ISEM Sensorelektronikmodul
XPD0071	Set ISEM, DN 25 ... 80 Modbus, Promass 10, Exd	1 × ISEM Sensorelektronikmodul
XPD0100	Set ISEM, DN 08 ... 80 IO-Link, Promass 10, nEx	1 × ISEM Sensorelektronikmodul
XPD0076	Set Elektronikmodul HART, 24VDC, nEx, Polycarbonat, 10	1 × Modulhalterung mit Energieversorgungsmodul, I/O-Modul
XPD0077	Set Elektronikmodul HART, 100-230VAC, nEx, Polycarbonat, 10	1 × Modulhalterung mit Energieversorgungsmodul, I/O-Modul
XPD0078	Set Elektronikmodul Modbus, 24VDC, nEx, Polycarbonat, 10	1 × Modulhalterung mit Energieversorgungsmodul, I/O-Modul
XPD0079	Set Elektronikmodul Modbus, 100-230VAC, nEx, Polycarbonat, 10	1 × Modulhalterung mit Energieversorgungsmodul, I/O-Modul
XPD0080	Set Elektronikmodul HART, 24VDC, nEx, Alu, 10	1 × Modulhalterung mit Energieversorgungsmodul, I/O-Modul
XPD0081	Set Elektronikmodul HART, 100-230VAC, nEx, Alu, 10	1 × Modulhalterung mit Energieversorgungsmodul, I/O-Modul

Bestellnummer	Set Original Ersatzteil	Inhalt
XPD0082	Set Elektronikmodul HART, 100-230VAC/24VDC nEx, Alu, 10	1 × Modulhalterung mit Energieversorgungsmodul, I/O-Modul
XPD0083	Set Elektronikmodul HART, 100-230VAC/24VDC, Exd/Z2, Alu, 10	1 × Modulhalterung mit Energieversorgungsmodul, I/O-Modul
XPD0084	Set Elektronikmodul Modbus, 100-230VAC/24VDC nEx/Exd/Z2, Alu, 10	1 × Modulhalterung mit Energieversorgungsmodul, I/O-Modul
XPD0096	Set Elektronikmodul IO-Link, nEx, Polycarbonat, 10	1 × Modulhalterung mit I/O-Modul
XPD0097	Set Elektronikmodul IO-Link, nEx, Alu, 10	1 × Modulhalterung mit × I/O-Modul
71505739	Set S+T-DAT Promag 10 nonEx, Exd/Z2	1 × DAT-Sensor
71505741	Set S+T-DAT Promass 10 nonEx, Exd/Z2	1 × DAT-Sensor
71505745	Set Anschlussklemmen, Proline 10	1 × Klemme steckbar 2-Pol 1 × Klemme steckbar 6-Pol
71631284	Set ISEM-Kabel, Promag 10, nEx/Exd/Z2	1 × Flachbandkabel
71631287	Set ISEM-Kabel, Promass 10, nEx/Exd/Z2	1 × Flachbandkabel



- Die Bestellnummer des Ersatzteilsets (auf dem Produktaufkleber der Verpackung) kann sich von der Produktionsnummer (auf dem Aufkleber direkt auf dem Ersatzteil) unterscheiden!
- Durch Eingabe der Produktionsnummer des Ersatzteiles im Ersatzteilfindetool kann die Bestellnummer des entsprechenden Ersatzteilsets ermittelt werden.
- Wir empfehlen Einbauanleitung und Verpackung immer zusammen aufzubewahren.

2 Bestimmungsgemäße Verwendung

- Eine defekte Einheit nur gegen eine funktionierende Einheit des gleichen Typs ersetzen.
- Nur Originalteile von Endress+Hauser verwenden.
- Im W@M Device Viewer prüfen, ob das Ersatzteil zum vorliegenden Gerät passt.



Bei einigen Geräten befindet sich im Inneren des Gerätes eine Ersatzteilübersicht. Ist das Ersatzteilset dort aufgelistet, entfällt die Überprüfung.

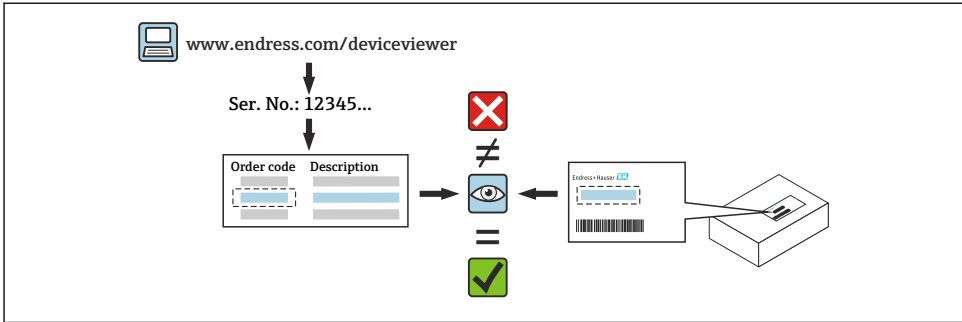

3 Reparaturberechtigte Personen

Die Berechtigung zur Durchführung einer Reparatur ist von der Zulassung des Messgeräts abhängig. Die Tabelle zeigt den jeweils berechtigten Personenkreis.

i Die Person, die eine Reparatur vornimmt, übernimmt die Verantwortung für die Sicherheit während der Arbeiten, die Qualität der Ausführung und die Sicherheit des Geräts nach der Reparatur.

Zulassung des Messgeräts	Reparaturberechtigter Personenkreis ¹⁾
Ohne Zulassung	1, 2, 3
Mit Zulassung (z.B. IECEx)	2, 3
Bei eichfähigem Verkehr	4

- 1) 1 = Ausgebildete Fachkraft des Kunden, 2 = Von Endress+Hauser autorisierter Servicetechniker, 3 = Endress+Hauser (Messgerät an Hersteller zurücksenden)
 4 = Mit der lokalen Zulassungsstelle prüfen, ob ein Ein-/Umbau unter Aufsicht erfolgen muss.

4 Sicherheitshinweise

- Prüfen, ob das vorliegende Ersatzteil zur Kennzeichnung auf dem Messgerät passt, wie auf der Titelseite beschrieben.
- Ersatzteilset und Einbauanleitung dienen dazu, eine defekte Einheit gegen eine funktionierende Einheit des gleichen Typs zu ersetzen.
Nur Originalteile von Endress+Hauser verwenden.
- Nationale Vorschriften bezüglich der Montage, elektrischen Installation, Inbetriebnahme, Wartung und Reparatur einhalten.
- Folgende Anforderungen an das Fachpersonal für Montage, elektrische Installation, Inbetriebnahme, Wartung und Reparatur der Messgeräte müssen erfüllt sein:
 - In Gerätesicherheit ausgebildet.
 - Mit den jeweiligen Einsatzbedingungen der Geräte vertraut.
 - Bei Ex-zertifizierten Messgeräten: zusätzlich im Explosionsschutz ausgebildet.

- Messgerät unter Spannung! Lebensgefahr durch Stromschlag. Messgerät nur im spannungslosen Zustand öffnen.
- Bei Messgeräten für den explosionsgefährdeten Bereich: Hinweise in der Ex-Dokumentation (XA) beachten.
- Bei Messgeräten in sicherheitstechnischen Applikationen gemäß IEC 61508 bzw. IEC 61511: Nach Reparatur Neuinbetriebnahme gemäß Betriebsanleitung durchführen. Reparatur dokumentieren.
- Vor einem Geräteausbau: Prozess in sicheren Zustand bringen und Leitung von gefährlichen Prozessstoffen befreien.
- Verbrennungsgefahr durch heiße Oberflächen! Vor Arbeitsbeginn: Anlage und Messgerät auf berührungssichere Temperatur abkühlen.
- Bei Messgeräten im abrechnungspflichtigen Verkehr: Nach Entfernen der Plombe ist der geeichte Zustand aufgehoben.
- Die Betriebsanleitung zum Messgerät ist zu beachten.
- Beschädigungsgefahr elektronischer Bauteile! Eine ESD-geschützte Arbeitsumgebung herstellen.
- Nach Entfernen der Elektronikabdeckung: Stromschlaggefahr durch aufgehobenen Berührungsschutz!
Messgerät ausschalten, bevor interne Abdeckungen entfernt werden.
- Änderungen am Messgerät sind nicht zulässig.
- Gehäuse nur kurzzeitig öffnen. Eindringen von Fremdkörpern, Feuchtigkeit oder Verunreinigung vermeiden.
- Defekte Dichtungen nur durch Original-Dichtungen von Endress+Hauser ersetzen.
- Defekte Gewinde erfordern eine Instandsetzung des Messgeräts.
- Gewinde (z.B. von Elektronikraum- und Anschlussraumdeckel) müssen geschmiert sein, sofern keine abriebfeste Trockenschmierung vorhanden ist. Säurefreies, nicht härtendes Fett verwenden.
- Wenn bei den Reparaturarbeiten Abstände reduziert oder die Spannungsfestigkeit des Messgeräts nicht sichergestellt werden kann: Prüfung nach Abschluss der Arbeiten durchführen (z.B. Hochspannungstest gemäß Herstellerangaben).
- Servicestecker:
 - Nicht in explosionsfähiger Atmosphäre anschließen.
 - Nur an Servicegeräte von Endress+Hauser anschließen.
- Die in der Betriebsanleitung aufgeführten Hinweise zum Transport und zur Rücksendung beachten.



Bei Fragen Endress+Hauser Service kontaktieren: www.addresses.endress.com

5 Verwendete Symbole

5.1 Warnhinweissymbole



Bezeichnet eine unmittelbar drohende Gefahr. Wenn sie nicht gemieden wird, sind Tod oder schwerste Verletzungen die Folge.

⚠️ WARNUNG

Bezeichnet eine möglicherweise drohende Gefahr. Wenn sie nicht gemieden wird, können Tod oder schwerste Verletzungen die Folge sein.



⚠️ VORSICHT

Bezeichnet eine möglicherweise drohende Gefahr. Wenn sie nicht gemieden wird, können leichte oder geringfügige Verletzungen die Folge sein.

HINWEIS

Bezeichnet eine möglicherweise schädliche Situation. Wenn sie nicht gemieden wird, kann das Produkt oder etwas in seiner Umgebung beschädigt werden.

5.2 Symbole für Informationstypen

Symbol	Bedeutung
	Erlaubt Abläufe, Prozesse oder Handlungen, die erlaubt sind.
	Verboten Abläufe, Prozesse oder Handlungen, die verboten sind.
	Tipp Kennzeichnet zusätzliche Informationen.
1, 2, 3...	Handlungsschritte

6 Werkzeugliste

 Innensechskant- schlüssel 3 mm, 5 mm	 Torx Schraubenzieher T10, T20	 Sechskantschlüssel	 Schlitzschrauben- zieher 0,5 x 3,5 mm	kunststoff- verträgliches Fett verwenden, wie z. B. Klübersynth R 42-111
---	---	--	---	---

7 Messumformergehäuse Ex-frei/Zone 2/Div. 2

⚠️ WARNUNG**Messgerät unter Spannung!**

Lebensgefahr durch Stromschlag.

- ▶ Messgerät nur im spannungslosen Zustand öffnen.

7.1 Öffnen Deckel Messumformergehäuse Alu

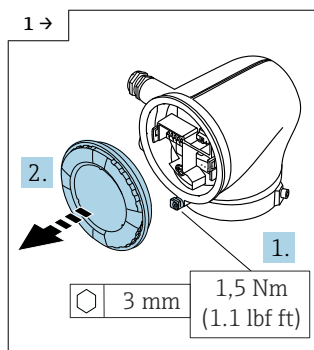

- ▶ Messumformergehäuse mit Deckel blind
- ▶ Schraube lösen und Deckel öffnen.

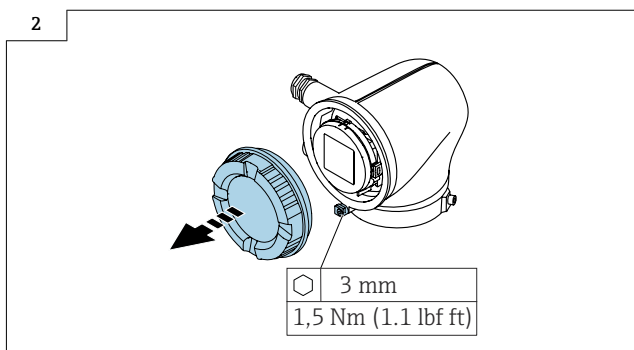

- ▶ Messumformergehäuse mit Deckel Schauglas
- ▶ Schraube lösen und Deckel öffnen.

7.2 Öffnen Deckel Messumformergehäuse Polycarbonat

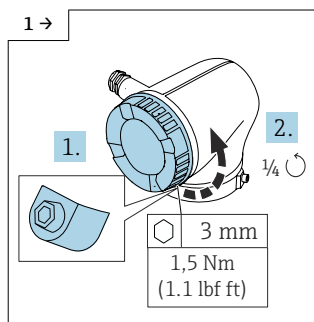

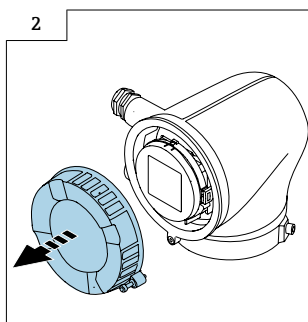

- ▶ Schraube soweit aus der Arretierung herausdrehen, bis sich der Deckel drehen lässt. Danach Deckel 1/4 Umdrehung entgegen dem Uhrzeigersinn drehen.



- ▶ Deckel wegnehmen.

7.3 Austausch Anschlussklemmen, Modulhalterung

Vorgehen wie in Kap. 7.1 →  35 oder wie in Kap. 7.2 →  35 und wie in den Bildern unten.

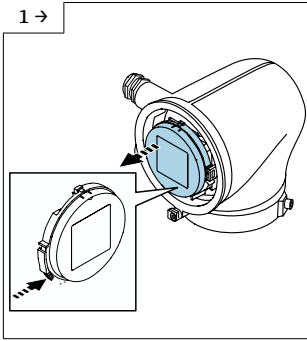

- ▶ Messumformergehäuse mit Anzeigemodul
- ▶ Lasche drücken und Anzeigemodul aus Messumformer herausnehmen.

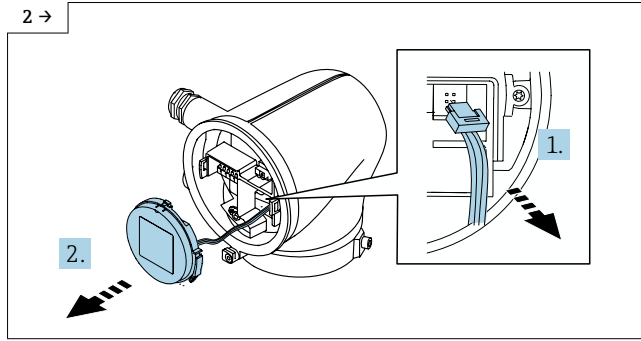

- ▶ Messumformergehäuse mit Anzeigemodul
- ▶ Lasche oberhalb vom Stecker nach oben drücken, Stecker abziehen, Anzeigemodul wegnehmen

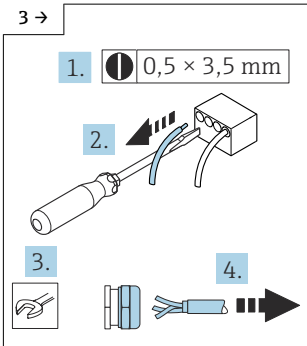

- ▶ Anschlusskabel lösen, Kabelverschraubung öffnen und Kabel wegnehmen.

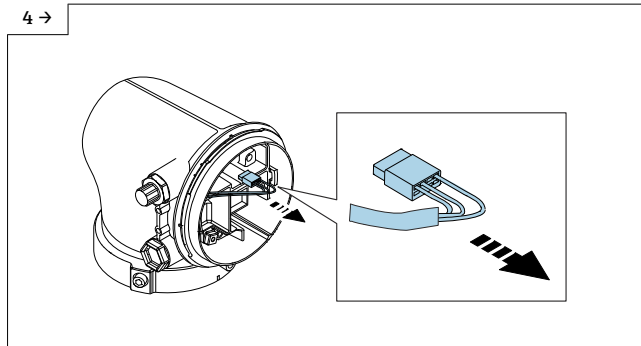

- ▶ Promag H: Steckverbindung zum Elektronikmodul lösen.

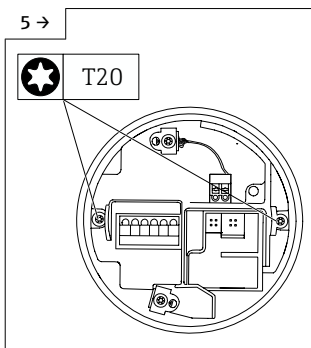

- ▶ Messumformergehäuse Alu
- ▶ 2 Torx Schrauben vom Elektronikmodul lösen.

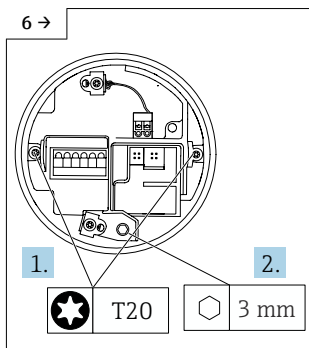

- ▶ Messumformergehäuse Polycarbonat
- ▶ 2 Torx Schrauben vom Elektronikmodul lösen, Erdungsschraube lösen.

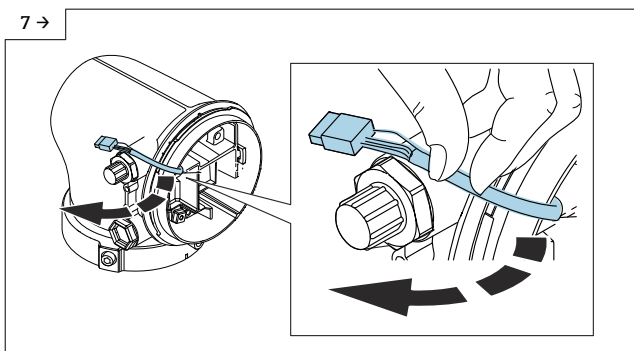

- ▶ Promag H: Kabel mit der Steckverbindung an die Aussparung des Elektronikmoduls führen und festhalten.

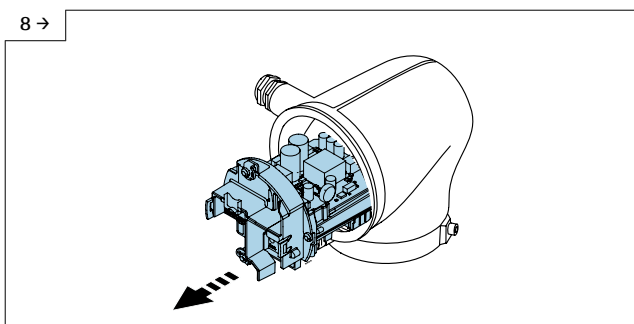

- ▶ Elektronikmodul soweit wie möglich aus Messumformergehäuse herausziehen.

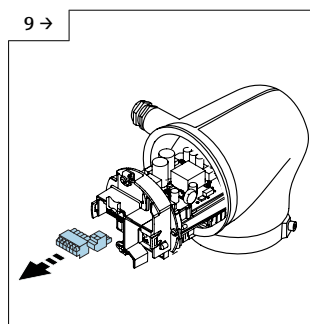

- ▶ Klemmen wegnehmen und austauschen.

10 →

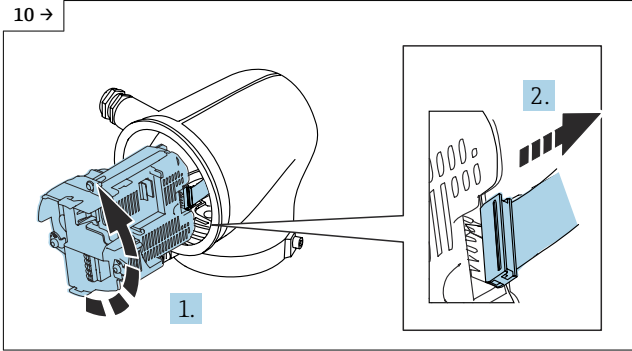

- ▶ Elektronikmodul gegen den Uhrzeigersinn um 90° drehen und an der Unterseite den Stecker des ISEM abziehen.

11

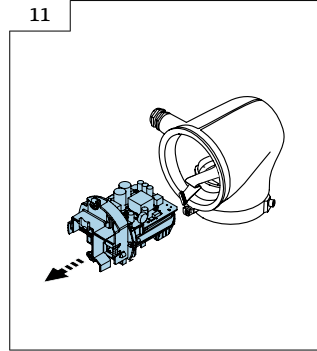

- ▶ Elektronikmodul aus Messumformergehäuse herausnehmen.

7.4 Austausch Flachbandkabel

▶ Vorgehen

- ↳ wie in Kap. 7.3 → 36 und wie in den Bildern unten.

1 →

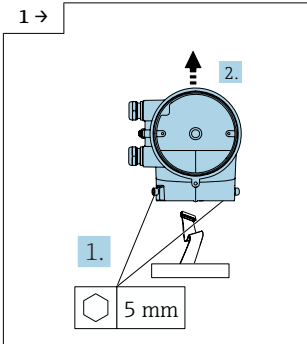

- ▶ Schrauben am Messumformergehäuse lösen, Messumformergehäuse hochziehen und ganz abziehen.

2 →

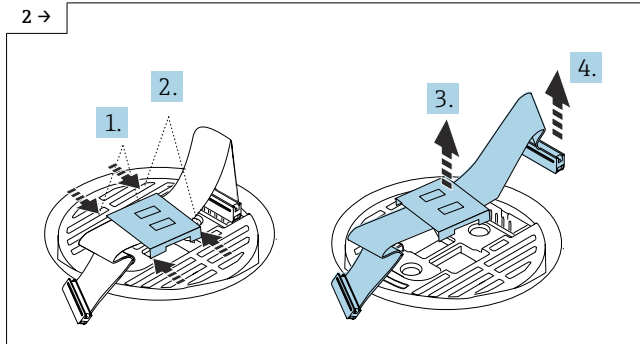

- ▶ **Promass:** Jeweils die beiden gegenüber liegenden Halterungen des Clips zusammendrücken, Clip vom ISEM lösen, Stecker abziehen und Flachbandkabel wegnehmen.

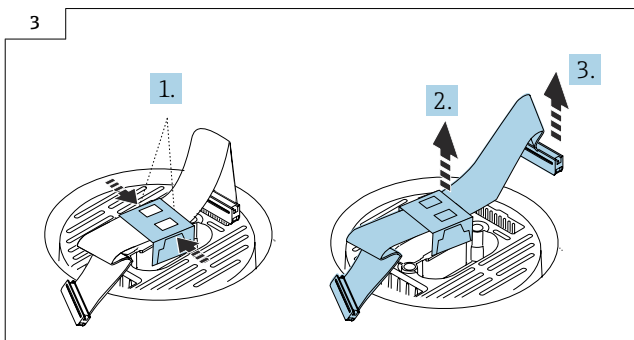

- **Promag:** Die gegenüber liegenden Halterungen des Clips zusammendrücken, Clip vom ISEM lösen, Stecker abziehen und Flachbandkabel wegnehmen.

7.5 Öffnen Messumformergehäuse Aluminium Ex db/Zone1/Div. 1, Austausch Anschlussklemmen, Modulhalterung

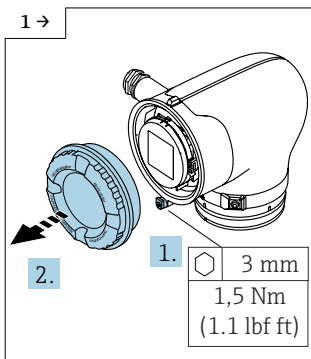

- Schrauben lösen und Deckel öffnen.

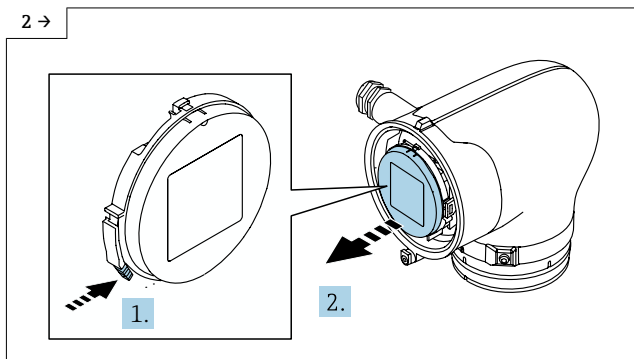

- Lasche drücken und Anzeigemodul aus Messumformer herausnehmen.

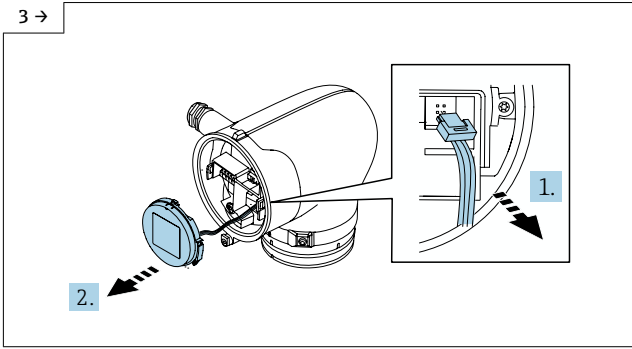

- ▶ Lasche oberhalb vom Stecker nach oben drücken, Stecker abziehen, Anzeigemodul wegnehmen.

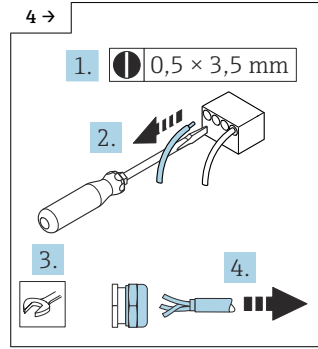

- ▶ Anschlusskabel lösen, Kabelverschraubung öffnen und Kabel wegnehmen.

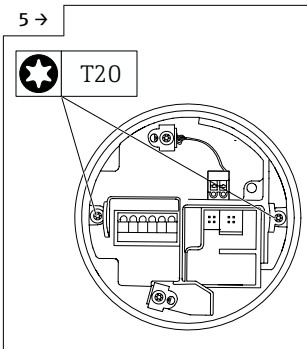

- ▶ Torx Schrauben vom Elektronikmodul lösen.

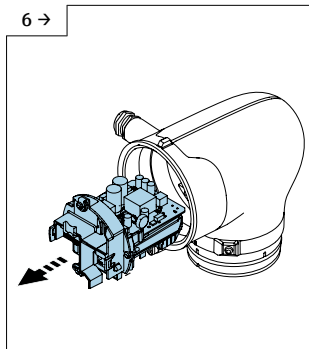

- ▶ Elektronikmodul soweit wie möglich aus Messumformergehäuse herausziehen.

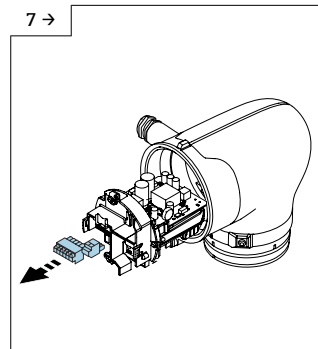

- ▶ Klemmen wegnehmen und austauschen.

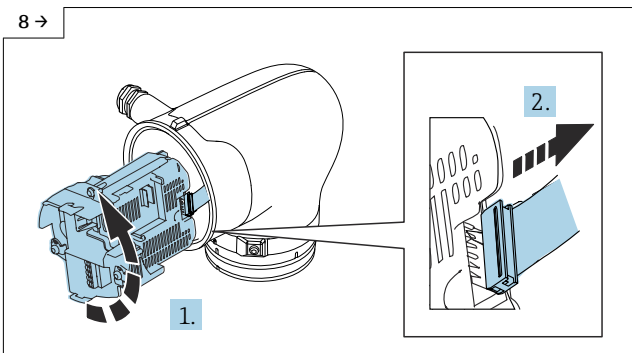

- ▶ Elektronikmodul gegen den Uhrzeigersinn um 90° drehen und an der Unterseite den Stecker des ISEM abziehen.

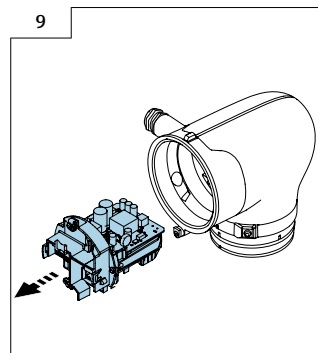

- ▶ Elektronikmodul ganz aus Messumformergehäuse herausnehmen.

7.6 Austausch Flachbandkabel

► Vorgehen

↳ wie in Kap. 7.5 →  39 und wie in den Bildern unten.

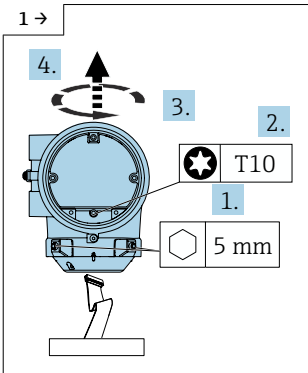

► Inbusschrauben rechts und links am Messumformergehäuse lösen, Verdrehsicherung lösen. Messumformergehäuse drehen und abziehen.

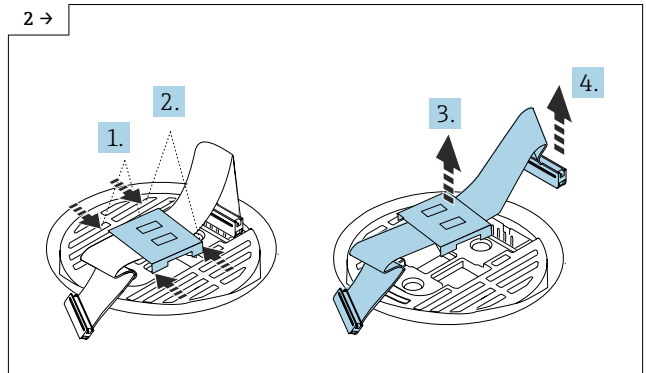

► **Promag:** Jeweils die beiden gegenüber liegenden Halterungen des Clips zusammendrücken, Clip vom ISEM lösen, Stecker abziehen und Flachbandkabel wegnehmen.

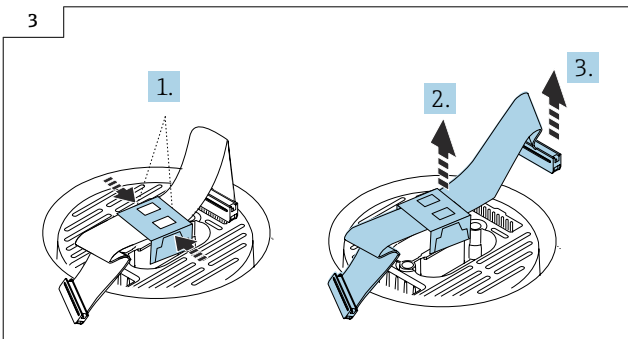

► **Promag:** Die gegenüber liegenden Halterungen des Clips zusammendrücken, Clip vom ISEM lösen, Stecker abziehen und Flachbandkabel wegnehmen.

8 Promag 10

8.1 Vorbereitende Arbeiten

Totalisatorwert auslesen und notieren.

 Nach Austausch S+T-DAT den notierten Wert wieder in das Gerät eingegeben.

8.2 Ausbau ISEM, S+T-DAT

► Messumformergehäuse Aluminium/Polycarbonat Ex-frei/Zone 2/Div. 2:

↳ Vorgehen wie in Kap. 7.4 →  38 Bild 1 und wie in den Bildern unten.

► Messumformergehäuse Aluminium Ex db/Zone1/Div. 1:

↳ Vorgehen wie in Kap. 7.6 →  41 Bild 1 und wie in den Bildern unten.

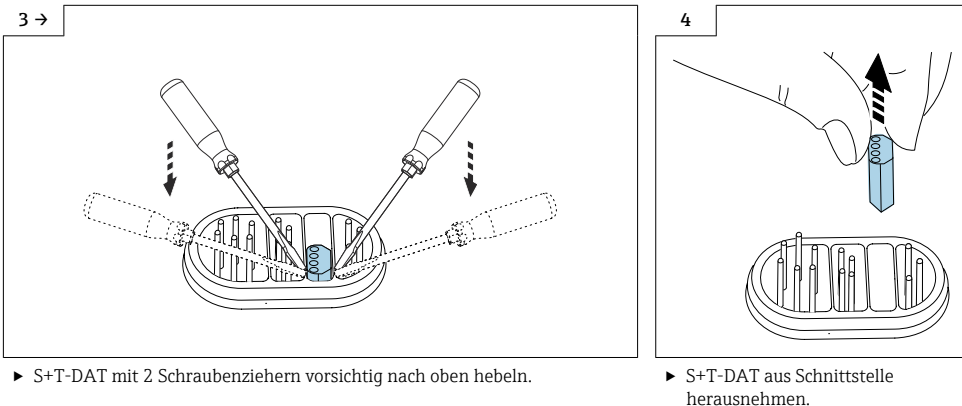
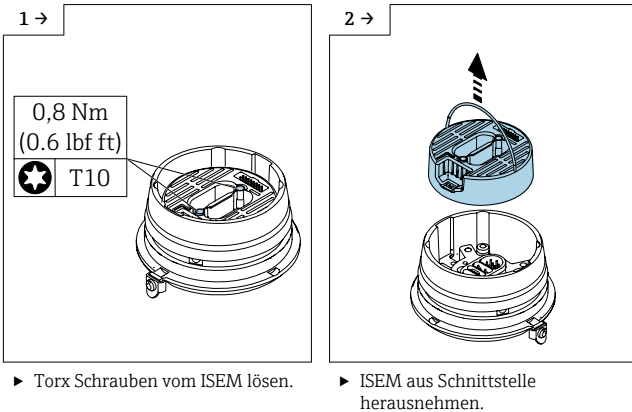

8.3 Vorbereitende Arbeiten Einbau ISEM für Messumformer Kompaktausführung

8.3.1 Option "Erdfreie Messung" deaktiviert oder aktiviert (erweiterter Messumformer)

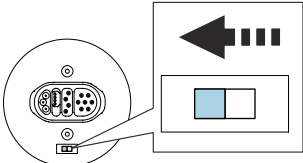
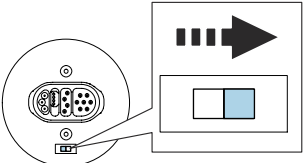
Option "Erdfreie Messung" deaktiviert (erweiterter Messumformer)	Option "Erdfreie Messung" aktiviert (erweiterter Messumformer)
<p>i Fehlerhafte Messperformance durch falsche Schalterstellung des Erdungsschalters beim erweiterten Messumformer! Korrekte Stellung des Erdungsschalters kontrollieren und falls notwendig korrigieren!</p>	<p>i Schäden am Messgerät durch falsche Schalterstellung des Erdungsschalters beim erweiterten Messumformer! Korrekte Stellung des Erdungsschalters kontrollieren und falls notwendig korrigieren!</p>
	

8.4 Vorbereitende Arbeiten Einbau ISEM für Messumformer Getrenntausführung

8.4.1 Option "Erdfreie Messung" deaktiviert oder aktiviert (erweiterter Messumformer)

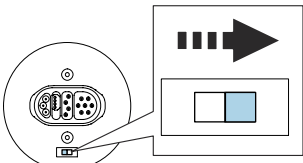
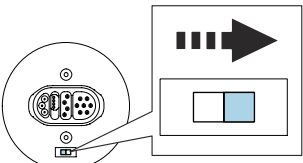
Option "Erdfreie Messung" deaktiviert (erweiterter Messumformer)	Option "Erdfreie Messung" aktiviert (erweiterter Messumformer)
<p>i Fehlerhafte Messperformance durch falsche Schalterstellung des Erdungsschalters beim erweiterten Messumformer! Korrekte Stellung des Erdungsschalters kontrollieren und falls notwendig korrigieren!</p>	<p>i Schäden am Messgerät durch falsche Schalterstellung des Erdungsschalters beim erweiterten Messumformer! Korrekte Stellung des Erdungsschalters kontrollieren und falls notwendig korrigieren!</p>
	

8.5 Einbau S+T-DAT, ISEM

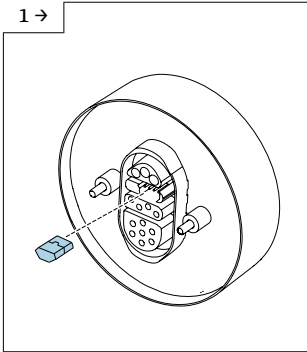

- Neues S+T-DAT in ISEM einstecken. **!** Pinbild beachten!

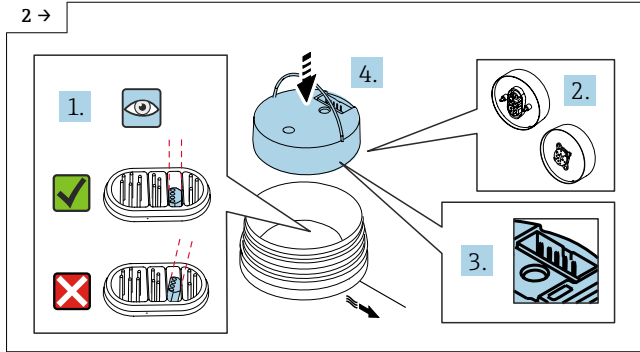

- **!** Vor dem Einsetzen des neuen ISEM kontrollieren, ob das neue S+T-DAT gerade steht, um eine Beschädigung der Pins zu vermeiden.

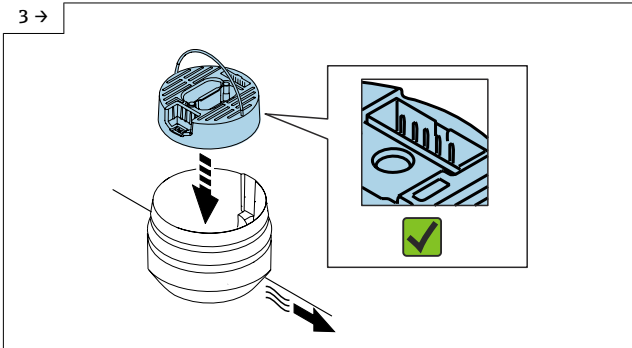

- ISEM gemäss Abbildung in Sensorschnittstelle ausrichten und platzieren. **!** Pinbild beachten!

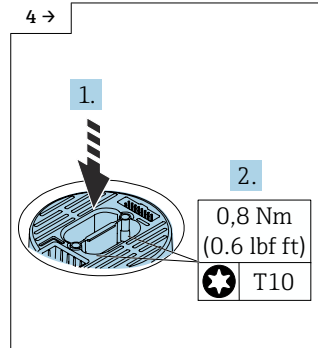

- ISEM vorsichtig nach unten drücken, Schrauben gemäss Drehmoment anziehen.

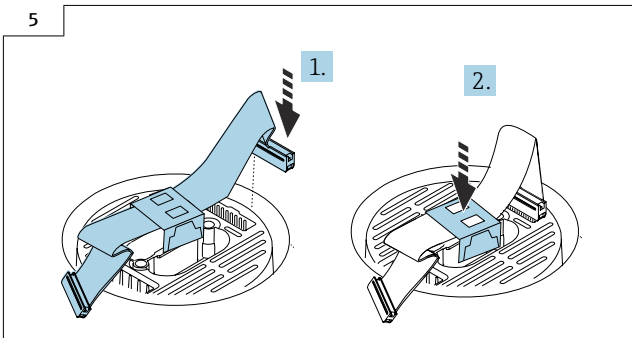

- Stecker vom Flachbandkabel einstecken und Flachbandkabel durch Befestigen des Clip am ISEM fixieren.

9 Promass 10

9.1 Vorbereitende Arbeiten

Totalisatorwert auslesen und notieren.

 Totalisatorwert auslesen und notieren.

 Nach Austausch S+T-DAT den notierten Wert wieder in das Gerät eingeben.

9.2 Ausbau ISEM S+T-DAT

▶ Messumformergehäuse Aluminium/Polycarbonat Ex-frei/Zone 2/Div. 2:

↳ Vorgehen wie in Kap. 7.4 →  38 Bild 1 und wie in den Bildern unten.

▶ Messumformergehäuse Aluminium Ex db/Zone1/Div. 1:

↳ Vorgehen wie in Kap. 7.6 →  41 Bild 1 und wie in den Bildern unten.

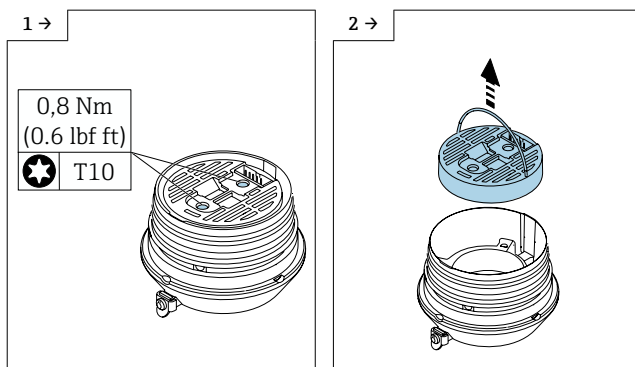

▶ Torx Schrauben vom ISEM lösen.

▶ ISEM aus Schnittstelle herausnehmen.

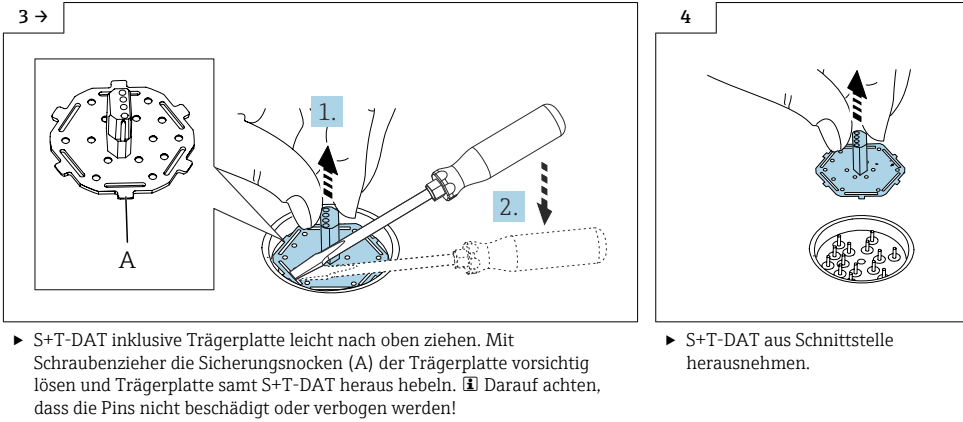

9.3 Einbau S+T-DAT, ISEM

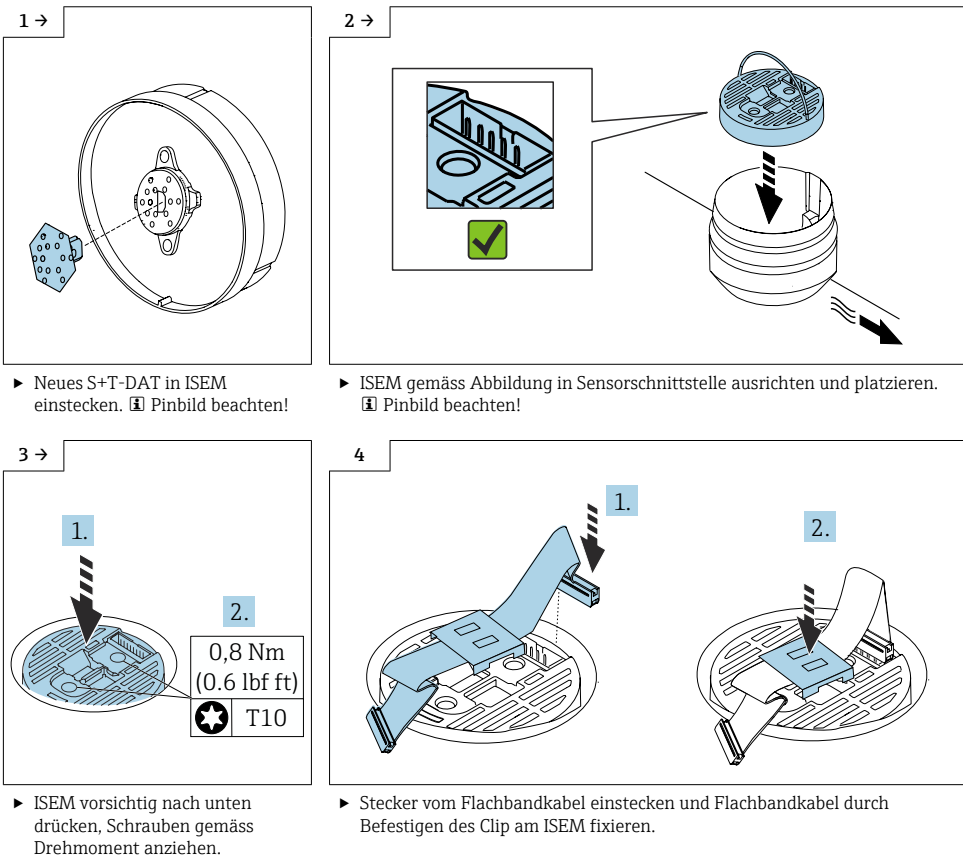

10 Zusammenbau

10.1 Einbau Messumformergehäuse Ex-frei/Zone 2/Div. 2

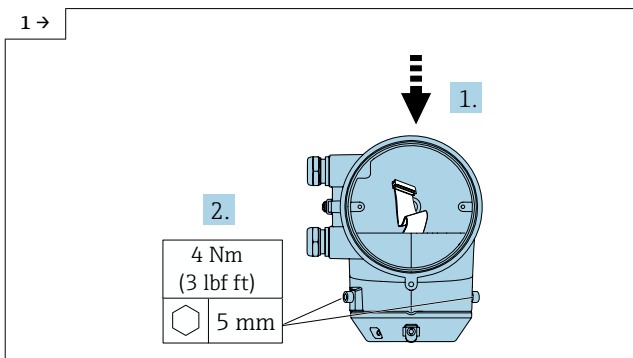

- ▶ Neues Messumformergehäuse aufsetzen und dabei das Flachbandkabel durch den Hals des Gehäuses führen. Schrauben am Messumformergehäuse anziehen.

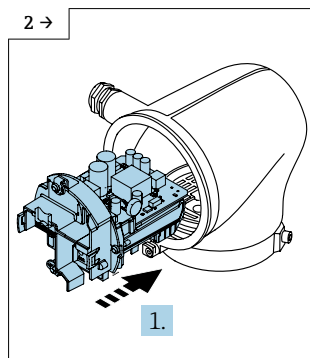

- ▶ Elektronikmodul vor dem Messumformergehäuse positionieren.

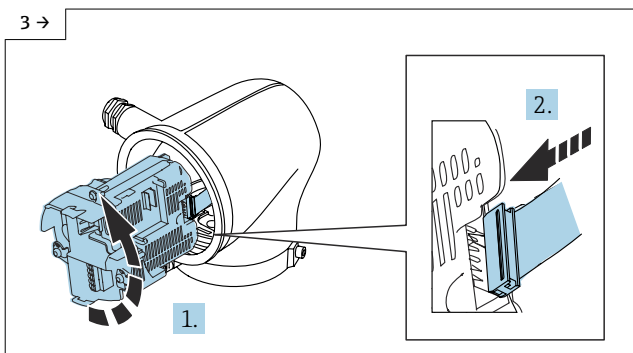

- ▶ Elektronikmodul gegen den Uhrzeigersinn um 90° drehen und an der Unterseite den Stecker des ISEM einstecken.

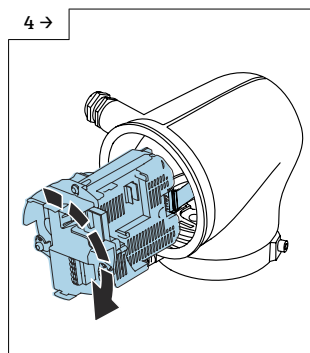

- ▶ Elektronikmodul im Uhrzeigersinn um 90° zurück drehen und vorsichtig in den Messumformer hineinschieben.

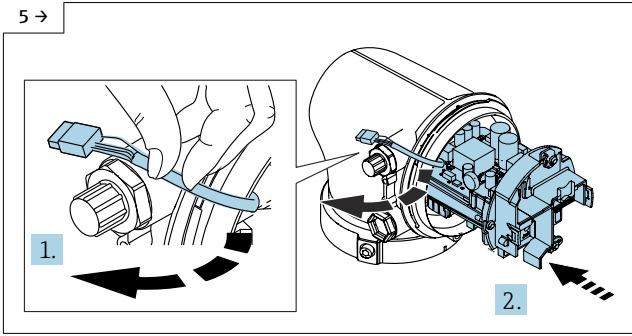

- ▶ **Promag H:** Kabel mit der Steckverbindung an die Aussparung des Elektronikmoduls führen und festhalten. Elektronikmodul vorsichtig einschieben.

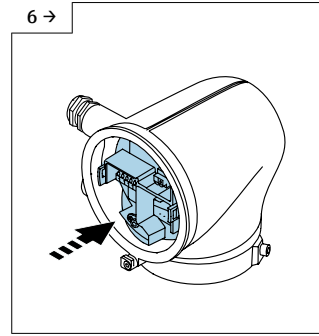

- ▶ Elektronikmodul ganz in den Messumformer hineinschieben.

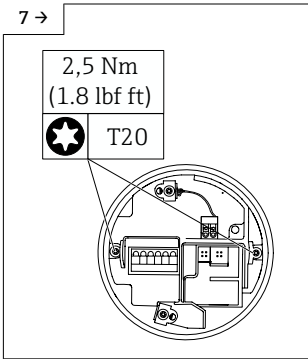

- ▶ **Messumformergehäuse Alu**
- ▶ 2 Torx Schrauben anziehen.

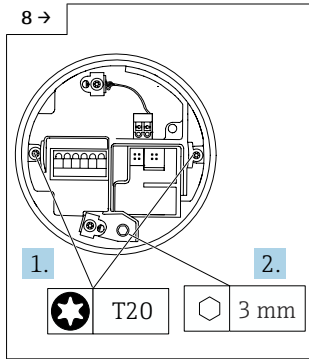

- ▶ **Messumformergehäuse Polycarbonat**
- ▶ 2 Torx Schrauben anziehen, Erdungsschraube anziehen.

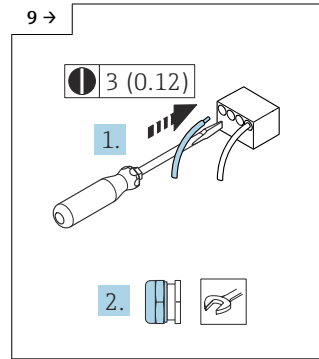

- ▶ Kabel gemäß Klemmenbelegung in der Betriebsanleitung anschließen. Kabelverschraubungen festziehen.

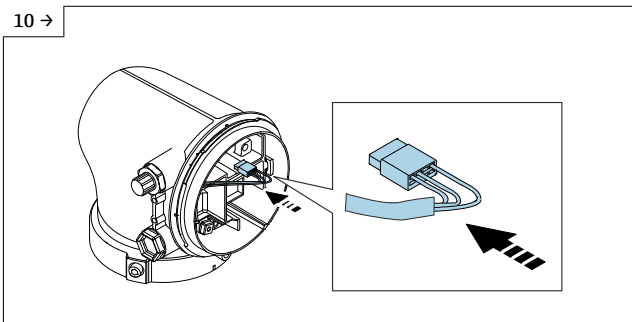

- ▶ **Promag H:** Steckverbinder zum Elektronikmodul einstecken.

11 →

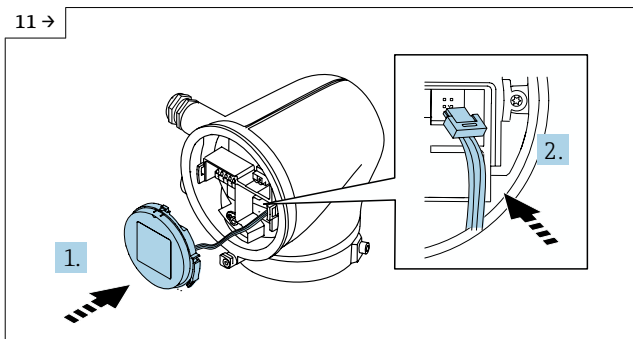

- ▶ Messumformergehäuse mit Anzeigemodul
- ▶ Stecker einstecken, Anzeigemodul an Messumformergehäuse aufsetzen.

12

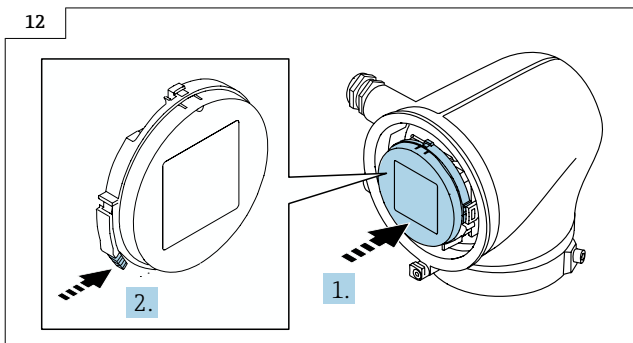

- ▶ Messumformer mit Anzeigemodul
- ▶ Anzeigemodul aufsetzen bis es einrastet.

10.2 Schließen Deckel Messumformergehäuse Alu

1 →

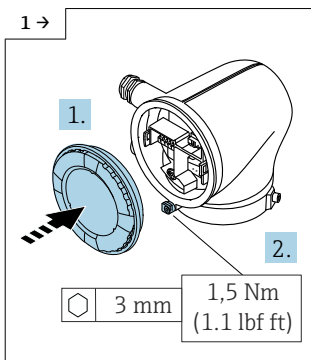

- ▶ Messumformergehäuse mit Deckel blind
- ▶ Deckel aufsetzen und Schraube anziehen.

2

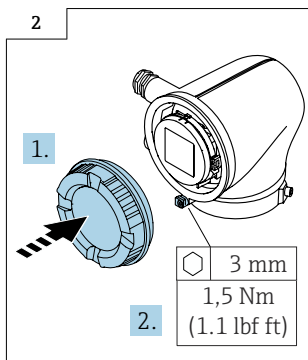

- ▶ Messumformergehäuse mit Deckel Schauglas
- ▶ Deckel aufsetzen und Schraube anziehen.

10.3 Schließen Deckel Messumformergehäuse Polycarbonat

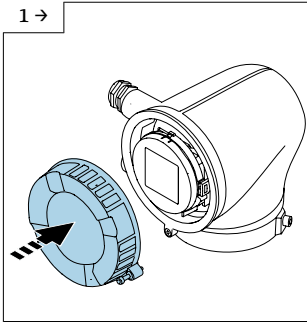

- ▶ Deckel aufsetzen.

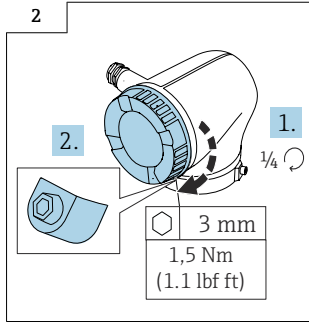

- ▶ Deckel 1/4 Umdrehung im Uhrzeigersinn drehen und Schraube anziehen.

10.4 Einbau Messumformergehäuse Ex db, Zone 1, Div. 1

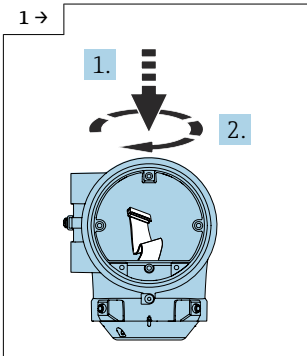

- ▶ Messumformergehäuse aufsetzen und dabei das Flachbandkabel durch den Hals des Gehäuses führen. Messumformergehäuse drehen.

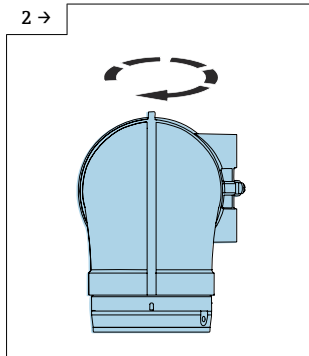

- ▶ Messumformergehäuse bis zum Anschlag vom Gewinde drehen.

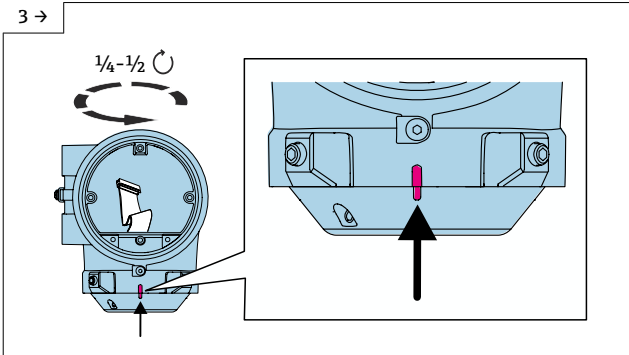

- Messumformergehäuse 1/2 Umdrehung zurück drehen bis beide Markierungen über einander stehen.

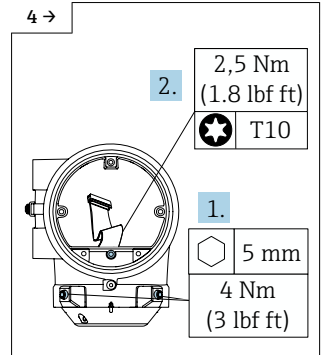

- Die Schrauben am Messumformergehäuse anziehen, die Verdrehsicherung anziehen.

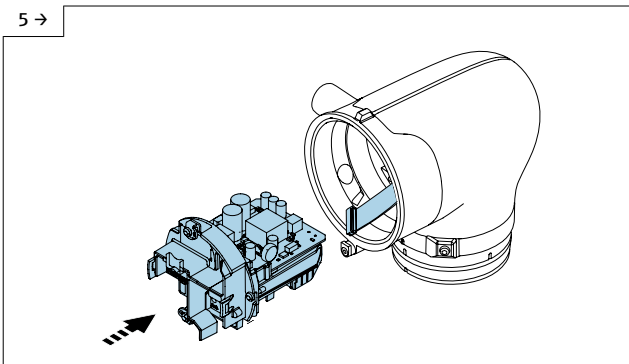

- Elektronikmodul vor dem Messumformergehäuse positionieren.

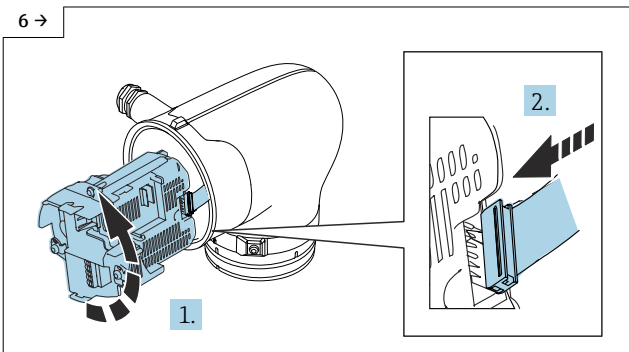

- Elektronikmodul gegen den Uhrzeigersinn um 90° drehen und an der Unterseite den Stecker des ISEM einstecken.

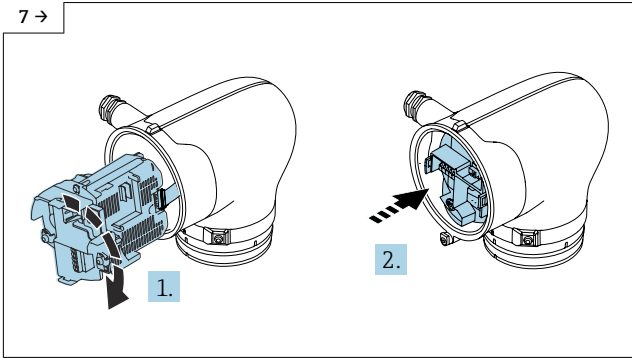

► Elektronikmodul im Uhrzeigersinn um 90° zurück drehen und vorsichtig in den Messumformer hineinschieben.

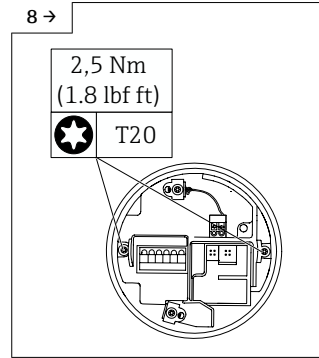

► Torx Schrauben anziehen.

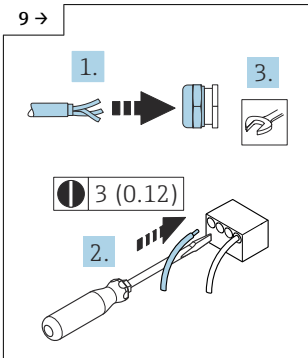

► Kabel gemäß Klemmenbelegung in der Betriebsanleitung anschließen. Kabelverschraubungen festziehen.

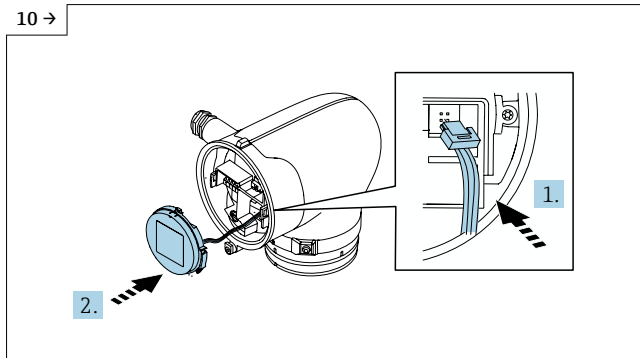

► Stecker einstecken, Anzeigemodul anbringen.

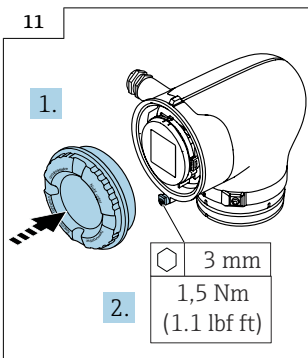

► Deckel schliessen und Schraube anziehen.

11 Abschliessende Arbeiten

11.1 Abschliessende Arbeiten nach Austausch Elektronikmodul

HINWEIS

Gültig für XPD0083- oder XPD0084:

Bei Eingang, Ausgang

- ▶ **Option C**
- ▶ 4-20mA HART, Impuls/Frequenz/Schaltausgang Ex-i
- ▶ **Option U**
- ▶ Modbus RS485, 4-20mA Ex-i
- ▶ Den mitgelieferten Exi-Aufkleber (siehe Grafik 1 unten) auf dem neuen Elektronikmodul an gleicher Stelle anbringen.

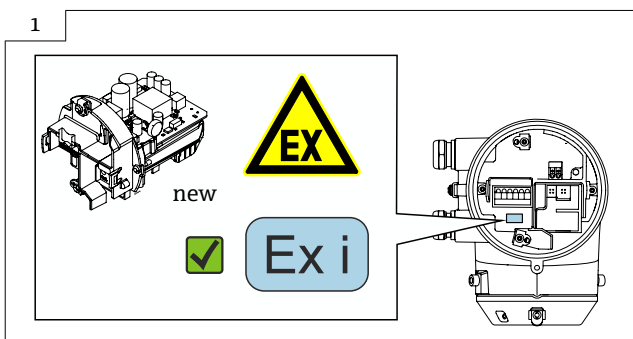

- ▶ Anbringen Exi-Aufkleber auf neuem Elektronikmodul.

11.2 Allgemeine abschliessende Arbeiten

i Nach Ausführung der unten genannten Schritte, erfolgt ein Geräte Neustart. Die Verbindung via SmartBlue App muss wieder hergestellt werden.

Totalizer

- ▶ Totalizer wieder einstellen.

12 Entsorgung

 Gemäß der Richtlinie 2012/19/EU über Elektro- und Elektronik-Altgeräte (WEEE) ist das Produkt mit dem abgebildeten Symbol gekennzeichnet, um die Entsorgung von WEEE als unsortierten Hausmüll zu minimieren. Gekennzeichnete Produkte nicht als unsortierter Hausmüll entsorgen, sondern zu den gültigen Bedingungen an den Hersteller zurückgeben.



71665209

www.addresses.endress.com
