



Brief Operating Instructions

Liquiphant FTL31

Level switch for liquids
IO-Link



These Brief Operating Instructions are not a substitute for the Operating Instructions pertaining to the device. Detailed information can be found in the Operating Instructions and the additional documentation.

Available for all device versions via:

- Internet: www.endress.com/deviceviewer
- Smartphone/tablet: Endress+Hauser Operations app

Basic safety instructions

Requirements for the personnel

The personnel must fulfill the following requirements to carry out their tasks, e. g. commissioning and maintenance:

- ▶ Trained specialists must have a qualification that is relevant to the specific function and task.
- ▶ Must be authorized by the plant owner/operator.
- ▶ Must be familiar with national regulations.
- ▶ Must have read and understood the instructions in the manual and supplementary documentation.
- ▶ Personnel must follow instructions and comply with general policies.

Intended use

The device described in this manual may be used only as a level switch for liquids. Incorrect use of the device may pose a hazard.

To ensure that the device remains in proper condition for the operation time:

- Use the device only for media to which the wetted materials have an adequate level of resistance
- Comply with the limit values, see the "Technical data" section of the Operating Instructions

Operational safety

Risk of injury!

- ▶ Operate the device only if it is in proper technical condition, free from errors and faults.
- ▶ The operator is responsible for the interference-free operation of the device.

Mounting



The mounting process is illustrated in the following section on the basis of sample configurations. For detailed information, see the Operating Instructions.

Mounting requirements

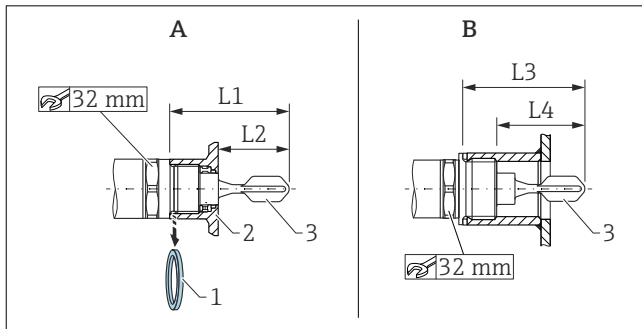

A Device with weld-in adapter

B Device in customer socket

1 Flat seal

2 Weld-in adapter

3 Vibrating fork

L1 With G 1" thread: 66,4 mm (2,61 in) / With G 3/4" thread: 63,9 mm (2,52 in)

L2 With G 1" thread: 48,0 mm (1,89 in) / With G 3/4" thread: 38,0 mm (1,5 in)

L3 With G 1" thread: 66,4 mm (2,61 in)

L4 With G 1" thread: 47,9 mm (1,8 in)

Installation is possible in any position in a vessel, pipe or tank under the following conditions:

- When installed horizontally in a vessel, the vibrating fork may be located in an installation socket only if liquids with low viscosity (< 2 000 mPa·s) are used.
- Minimum diameter of installation socket: 50 mm (2.0 in)
- Select a maximum length for the installation socket that enables the vibrating fork to project freely into the vessel.
- Ensure that there is sufficient distance between the expected buildup on the tank wall and the vibrating fork. Recommended distance from wall ≥ 10 mm (0.39 in).

Important process conditions

Pressure and temperature (maximum):

- With weld-in adapter
 - +25 bar (+362 psi) at +150 °C (+302 °F)
 - +40 bar (+580 psi) at +100 °C (+212 °F)
- In customer socket
 - +40 bar (+580 psi) at +150 °C (+302 °F)

Altitude:

Up to 2 000 m (6 600 ft) above sea level



In the case of seals used at the customer site, pay attention to the temperature and pressure specifications.

Mounting the device

An open-ended wrench (AF 32) is required for mounting.

- i** For the NTP thread (ANSI B 1.20.1): use sealing material (PTFE) if necessary.
- i** For the weld-in adapter with a flush-mount seal: remove the supplied flat seal (1) from the thread.
- i** For the weld-in adapter with leakage hole: make sure the leakage hole points downwards.

Aligning the vibrating fork

- i** The material specification (e.g. 316L) or the thread designation (e.g. G 3/4) on the device are positioned in line with the opening of the vibrating fork and are therefore used for orientation.

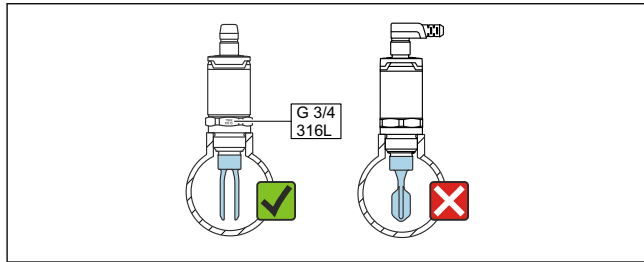

1 In the pipe: align the opening of the vibrating fork parallel to the flow direction in such a way that the liquid can flow unhindered between the two vibrating fork elements.

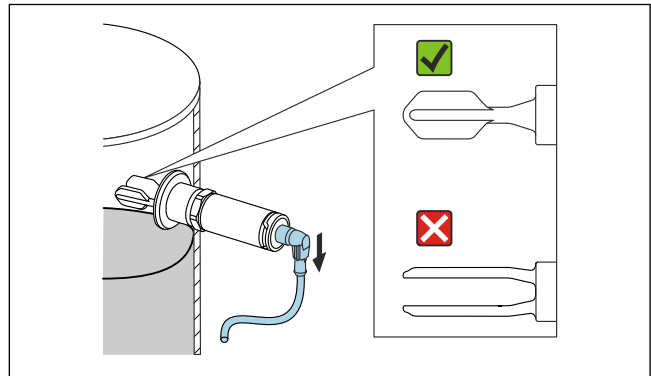

- 2 For horizontal installation in a vessel: align the vibrating fork in such a way that both vibrating fork elements are simultaneously covered with liquid.
- Fix the device with a maximum torque of 30 Nm (22 lbf ft). Also pay attention to the alignment of the vibrating fork when doing so.

Electrical connection

- i** The connection with the M12 plug with IO-Link communication is presented in the following section. For other connection options, see the Operating Instructions.
- i** For data and the wiring of the electronic version SIO mode, see the Operating Instructions.
- i** A suitable circuit breaker must be provided for the device in accordance with IEC/EN 61010.

Power supply

Electronic version	Supply voltage	Power consumption	Current consumption
4-wire DC-PNP, IO-Link	18 to 30 V _{DC}	< 975 mW	< 15 mA

Reverse polarity protection	Integrated. In the event of reverse polarity, the device is deactivated automatically.
------------------------------------	----------------------------------------------------------------------------------------

Connection with M12 plug

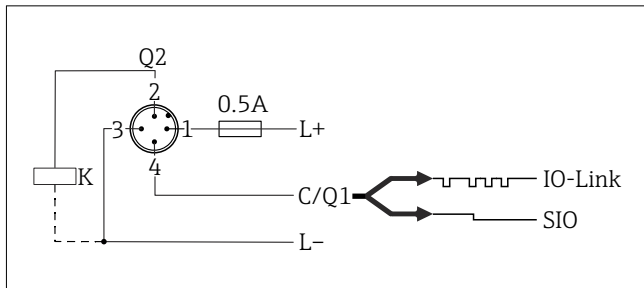

Pin 1 Supply voltage +

- Pin 2 1st switch output
- Pin 3 Supply voltage -
- Pin 4 IO-Link communication or 2nd switch output (SIO mode)

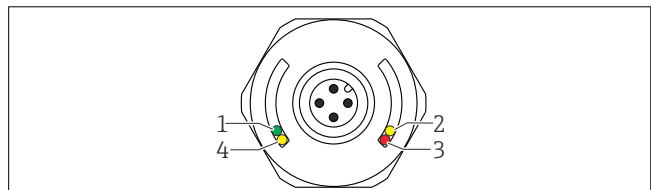

Item	LED color	Description of function
1	Green	Status/communication <ul style="list-style-type: none"> ■ Lit: SIO mode ■ Flashing: active communication, flash frequency ■ Flashing with increased luminosity: device search (device identification), flash frequency
2	Yellow 1	Switch status/switch output 1 With IO-Link communication following customer calibration: sensor is covered by medium.
3	Red	Warning/Maintenance required Flashing: error remediable, e.g. invalid calibration Fault/device failure Lit: → Diagnostics and troubleshooting
4	Yellow 2	Switch status/switch output 2 ¹⁾ With IO-Link communication following customer calibration: sensor is covered by medium.

1) Activated only if both switch outputs are active.

- i** On the metal housing cover (IP69), there is no external signaling via LEDs.