

# Functional Safety Manual

## **HAW568**

Surge Protective Device  
for DIN rail according to EN 60715



## Table of contents

<b>1</b>	<b>About this document</b> .....	<b>3</b>
1.1	Symbols .....	3
1.1.1	Safety symbols .....	3
1.1.2	Symbols for certain types of information and graphics .....	3
1.2	Abbreviations .....	3
1.3	Supplementary device documentation .....	4
<b>2</b>	<b>Design</b> .....	<b>4</b>
2.1	Introduction .....	4
2.1.1	Relevant standards .....	4
2.2	Identification marking .....	4
2.3	Description of safety function .....	5
2.3.1	Safety function and safe state .....	5
2.3.2	Safety integrity requirements .....	5
<b>3</b>	<b>Commissioning (Mounting and electrical connection)</b> .....	<b>6</b>
3.1	Mounting .....	6
3.2	Electrical connection .....	6
<b>4</b>	<b>Operation</b> .....	<b>6</b>
4.1	Descriptions of application requirements .....	6
4.2	Application .....	6
<b>5</b>	<b>Proof test</b> .....	<b>7</b>
5.1	Requirements of Proof test .....	7
5.1.1	Test wiring diagram .....	9
<b>6</b>	<b>Repair and error handling</b> .....	<b>9</b>
6.1	Maintenance .....	9

# 1 About this document

## 1.1 Symbols

### 1.1.1 Safety symbols

#### DANGER

This symbol alerts you to a dangerous situation. Failure to avoid this situation will result in serious or fatal injury.

#### WARNING

This symbol alerts you to a potentially dangerous situation. Failure to avoid this situation can result in serious or fatal injury.

#### CAUTION

This symbol alerts you to a potentially dangerous situation. Failure to avoid this situation can result in minor or medium injury.

#### NOTICE

This symbol alerts you to a potentially harmful situation. Failure to avoid this situation can result in damage to the product or something in its vicinity.

### 1.1.2 Symbols for certain types of information and graphics

#### Tip

Indicates additional information



Reference to documentation

## 1.2 Abbreviations

SPD	Surge protective device
CCF	Common cause failures
FIT	Failure in time
FMEA	Failure mode and effects analysis
$\lambda_s$	Probability of safe failure
$\lambda_D$	Probability of dangerous failure
$\lambda_{DD}$	Probability of dangerous detected failure
$\lambda_{DU}$	Probability of dangerous undetected failure
$\lambda_{NE}$	No effect failure
HFT	Hardware fault tolerance
HW	Hardware
MRT	Mean repair time
MTTR	Mean time to repair
$PFD_{AVG}$	Average probability of failure on demand
PFH	Average frequency of dangerous failure [h <sup>-1</sup> ]
SFF	Safe failure fraction
T1	Proof test interval
Response time	From the input signal access to the output reaches 90 % of final value
Fault reaction time	Time from fault occurred to the module enters into a safe state

$T_{RC}$	Response time of the contact closure
$T_{RR}$	Response time of the contact release
$U_c$	Maximum continuous operating voltage
$U_p$	Voltage protection level
$I_L$	Rated load current

### 1.3 Supplementary device documentation

 The following document types are available on the product pages and in the download area of the Endress+Hauser website [www.endress.com](http://www.endress.com):

- Technical Information (TI)
- Brief Operating Instructions (KA)
- Safety Instructions (XA)

## 2 Design

### 2.1 Introduction

The present specification shows the safety requirements for the development of the HAW568 series surge protective device. The device is used for protecting measuring and control circuits, bus systems and communication systems from being damaged by lightning surge or operating overvoltage.

The device consists of a protection module and a base module.

 For more information about products: [www.endress.com](http://www.endress.com).

#### 2.1.1 Relevant standards

Functional safety	
IEC 61508 parts 1-7:2010	Functional safety of electrical/electronic/programmable electronic safety related systems
Other Requirements	
IEC 61643-21:2012	Low-voltage surge protective devices – Part 21: Surge protective devices connected to telecommunications and signaling networks – Performance requirements and testing methods.

### 2.2 Identification marking

SIL-certified devices are marked with the SIL logo  on the nameplate.

## 2.3 Description of safety function

### 2.3.1 Safety function and safe state

#### Safety function

The safety function of the device is to behave like a piece of copper wire, passing through the process signal without being altered.

#### Safe state

 The safe state of the device depends on the application.

- Lead breakage and short circuit are out of range and counted as safe failures with external diagnostics.
- Lead breakage or short circuit without external diagnostic is considered dangerous and undetectable failures.

### 2.3.2 Safety integrity requirements

Operation mode	Low and high demand
HFT	0
Type	A
SFF	≥ 90 % (with external diagnostics) <sup>1)</sup>
Proof test interval	≥ 20 years
MRT	1 Hour
MTTR	8 Hours
SC	SC3
SIL	SIL3

- 1) The SIL 3 result has taken into consideration external diagnostics that may be available when the device is integrated into a SIS. The hardware/software failures of the assumed diagnostics is outside the scope of this certification and must be considered at system level by the integrator.

All the safety parameters calculations are based on the assumptions:

- Failure rate of each component is based on the Quanterion Automated Databook.
- Component failure rates are constant over the life of the device.
- Operating temperature: -40 to +80 °C.

FMEA Summary for the HAW568 series (with external diagnostics)					
Model	λSU	λSD	λDD	λDU	SFF
HAW568-AAB**2* HAW568-NCB**2*	4.52E-09	0.00E+00	8.39E-09	0.00E+00	100 %
HAW568-AAB**3* HAW568-NCB**3*	9.03E-09	0.00E+00	1.68E-08	0.00E+00	100 %
HAW568-AAB**4* HAW568-NCB**4*	9.03E-09	0.00E+00	1.68E-08	0.00E+00	100 %
HAW568-AAA**2* HAW568-NBA**2*	4.77E-09	0.00E+00	1.05E-08	2.59E+00	98.33 %
HAW568-AAA**3* HAW568-NBA**3*	9.42E-09	0.00E+00	1.99E-08	3.89E+00	98.69 %
HAW568-AAA**4* HAW568-NBA**4*	9.55E-09	0.00E+00	2.09E-08	5.18E+00	98.33 %

## 3 Commissioning (Mounting and electrical connection)

### 3.1 Mounting

The mounting of the device is described in the Operating Instructions pertaining to the device.



KA01727K

### 3.2 Electrical connection

The electrical connection of the device is described in the Operating Instructions pertaining to the device.



KA01727K

## 4 Operation

### 4.1 Descriptions of application requirements

Ambient temperature	-40 to +80 °C
Storage temperature	-40 to +85 °C
Relative humidity	5 to 95 %, no condensation
Rated operating voltage $U_n$	24 DC
Max. operating voltage $U_c$	48 V <sub>DC</sub>
Operating altitude	≤ 2 000 m
IP protection level	IP66/IP67

### 4.2 Application

This chapter shows how to integrate a surge protective device into a safety loop:

Application examples:

- Identify the signal characteristic of the safety loop:
  - Analog
  - Digital
- Determine the signal direction of the safety loop as seen from the perspective of the safety-rated programmable logic controller (SPLC):
  - Input
  - Output
- Evaluate the safe state of the field device allocated to the surge protective device.
- Configure the mode of operation:
  - Low demand mode
  - High demand mode
- Conclude the required SIL level of the safety loop. After the safety loop is defined, assign a surge protective device to the field device. Create a basic overview as shown below.

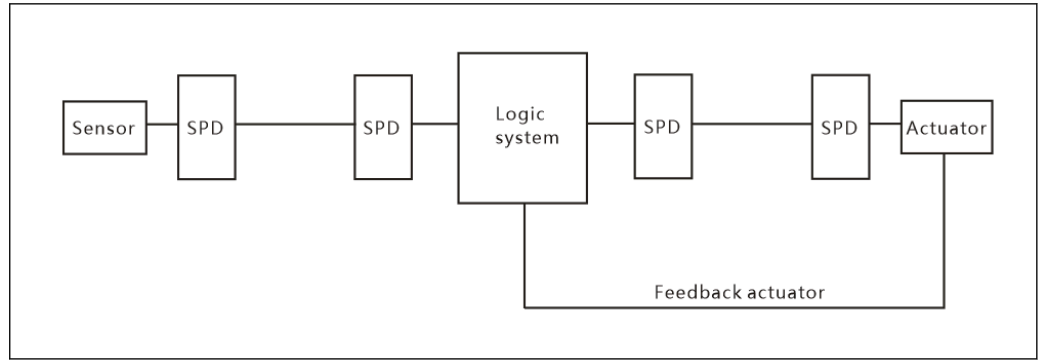

A0056716

## 5 Proof test

### 5.1 Requirements of Proof test

- This device must be subjected to a full test at least once every 5 years.
- The current, voltage and resistance are measured according to the table below to make sure that the product performance is reliable.
- The colors of the wires are used to represent the terminals of the products, such as red, black, blue, gray and yellow green.

HAW568-AAB**2* HAW568-NCB**2*	Test	Target
1	DC spark-over voltage red - yellow green black - yellow green	65 to 150 V
2	Breakdown voltage, 1 mA red - black	53 to 59 V <sub>DC</sub>
3	Reverse leakage, 48 V red - black	< 1 μA
HAW568-AAB**3* HAW568-NCB**3*	Test	Target
1	DC spark-over voltage red - yellow green black - yellow green blue - yellow green	65 to 150 V
2	Breakdown voltage, 1 mA red - black blue - black	53 to 59 V <sub>DC</sub>
3	Reverse leakage, 48 V red - black blue - black	< 1 μA
HAW568-AAB**4* HAW568-NCB**4*	Test	Target
1	DC spark-over voltage red - yellow green black - yellow green blue - yellow green gray - yellow green	65 to 150 V
2	Breakdown voltage, 1 mA red - black blue - gray	53 to 59 V <sub>DC</sub>

3	Reverse leakage, 48 V red - black blue - gray	< 1 $\mu$ A
<b>HAW568-AAA**2*</b> <b>HAW568-NBA**2*</b>	<b>Test</b>	<b>Target</b>
1	DC spark-over voltage red - yellow green black - yellow green	480 to 720 V
2	Breakdown voltage, 1 mA red - black	53 to 59 V <sub>DC</sub>
3	Reverse leakage, 48 V red - black	< 1 $\mu$ A
4	Resistance red - red black - black	$0.8 \Omega \leq R \leq 2.0 \Omega$
<b>HAW568-AAA**3*</b> <b>HAW568-NBA**3*</b>	<b>Test</b>	<b>Target</b>
1	DC spark-over voltage red - yellow green black - yellow green blue - yellow green	480 to 720 V
2	Breakdown voltage, 1 mA red - black blue - black	53 to 59 V <sub>DC</sub>
3	Reverse leakage, 48 V red - black blue - black	< 1 $\mu$ A
4	Resistance red - red black - black blue - blue	$0.8 \Omega \leq R \leq 2.0 \Omega$
<b>HAW568-AAA**4*</b> <b>HAW568-NBA**4*</b>	<b>Test</b>	<b>Target</b>
1	DC spark-over voltage red - yellow green black - yellow green blue - yellow green gray - yellow green	480 to 720 V
2	Breakdown voltage, 1 mA red - black blue - gray	53 to 59 V <sub>DC</sub>
3	Reverse leakage, 48 V red - black blue - gray	< 1 $\mu$ A
4	Resistance red - red black - black blue - blue gray - gray	$0.8 \Omega \leq R \leq 2.0 \Omega$



### 5.1.1 Test wiring diagram

DC spark-over voltage test diagram for HAW568-**\*\*B\*\*4\*** and HAW568-**\*\*A\*\*4\***:

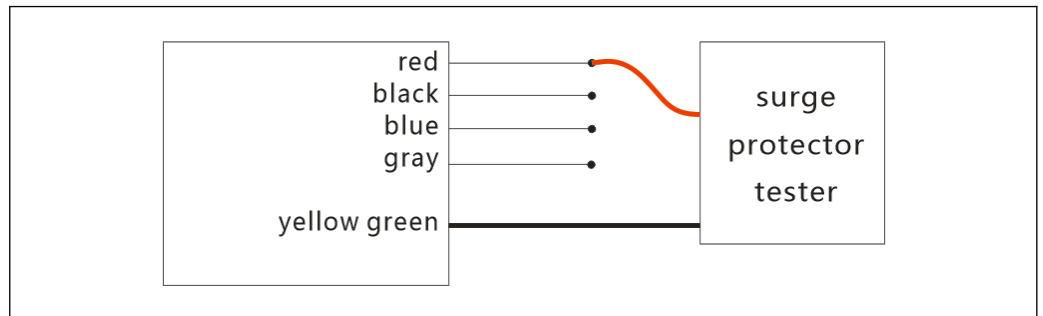

A0056724

Breakdown voltage and reverse leakage test diagram for HAW568-**\*\*B\*\*4\*** and HAW568-**\*\*A\*\*4\***:

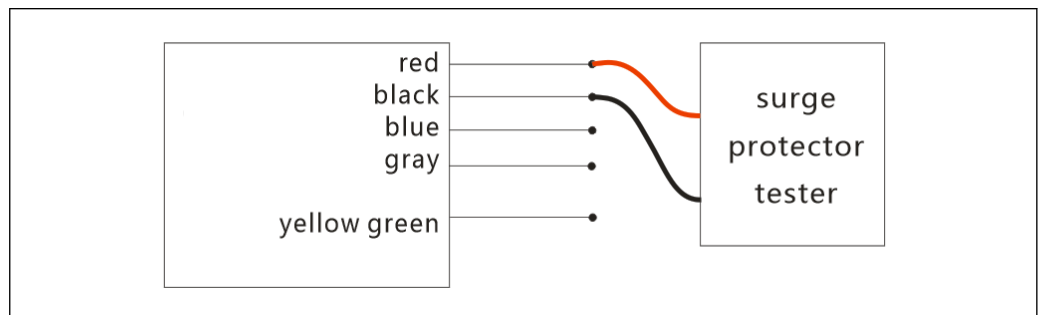

A0056726

Resistance test diagram for HAW568-**\*\*A\*\*4\***:

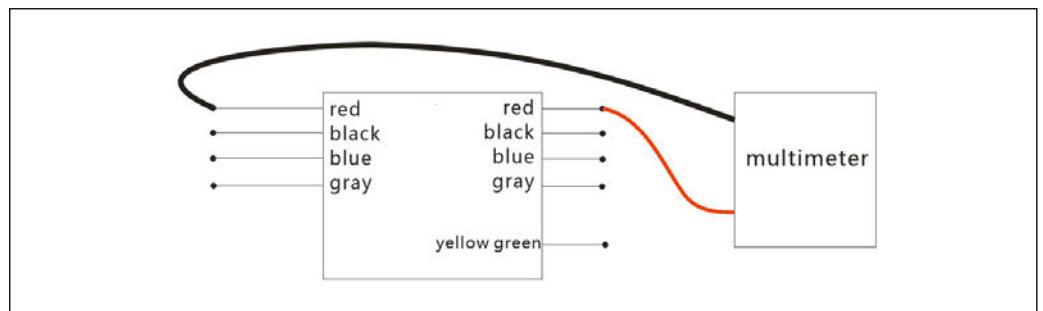

A0056728

## 6 Repair and error handling

### 6.1 Maintenance

- Check if the connections are correct and tight before powering on surge protective devices.
- The surge protective devices are well controlled and strictly inspected before delivery. If non-functional ones are found during operation, please contact Endress+Hauser early enough.
- Within 1 year of delivery, any problems occurred during normal operations can get treatments for free.







[www.addresses.endress.com](http://www.addresses.endress.com)

---