

Technical Information

Rxn-45 Raman spectroscopic probe

The ultimate in compatibility for bioprocess manufacturing

Application

The Raman Rxn-45 probe capitalizes on the power of Raman in bioprocess manufacturing by measuring multiple, specific components in real-time for continuous, around-the-clock process feedback. It also meets the daunting sampling requirements of compliance, sterilization, port compatibility, and convenience. The Raman Rxn-45 probe was designed for installation in development and cGMP stainless-steel reactors and is successfully used to provide an analytical “eye” into large-scale bioprocesses.

- **Cell culture:** glucose, lactate, amino acids, cell density, titer, and more
- **Fermentation:** glucose, glycerol, acetate, methanol, ethanol, biomass, and more

Device properties

- 6061 aluminum, 316L stainless steel, and 303 stainless steel
- PG13.5 for industry standard sensor housings, welded port connectors available
- Ra 15 with electropolish

Your benefits

- Measures multiple components in real-time for automated 24/7 process feedback
- Provides long-term measurement stability
- Offers a suitable surface finish for cGMP manufacturing
- Provides compatibility with industry standard bioreactor side ports and sensor housings
- Offers the flexibility of being installed in development and production reactors
- Reduces sterilization and cleaning burdens with CIP/SIP standard compatibility



Table of Contents

Function and system design	3
Application	3
Laser safety interlock	3
Rxn-45 probe.....	3
Installation	4
Data collection zone: short.....	4

Specifications.....	5
General specifications.....	5
Probe dimensions.....	6
MPE : ocular exposure	6
MPE: skin exposure.....	7

Function and system design

Application

Use of the device for any purpose other than that described, poses a threat to the safety of people and of the entire measuring system and invalidates any warranty.

Laser safety interlock

The Rxn-45 probe, as installed, forms part of the interlock circuit. The interlock circuit is a low-current electrical loop. If the fiber cable is severed, the laser will turn off within milliseconds of the breakage.

NOTICE

Permanent damage may result if cables are not routed appropriately.

- ▶ Handle probes and cables with care, ensuring they are not kinked.
- ▶ Install fiber cables with a minimum bend radius according to the *Raman fiber-optic cable Technical Information (TIO1641C)*.

The electro-optical (EO) fiber cable with its embedded interlock loop must be plugged into the back of the Raman Rxn analyzer for the appropriate channel. The interlock loop is complete when the probe side of the EO fiber cable is plugged into the Rxn-45 probe.

When there is potential for the laser to be energized, the laser interlock indicator light on the probe body is illuminated.

Rxn-45 probe

The Rxn-45 probe with the right angle connection is shown below.

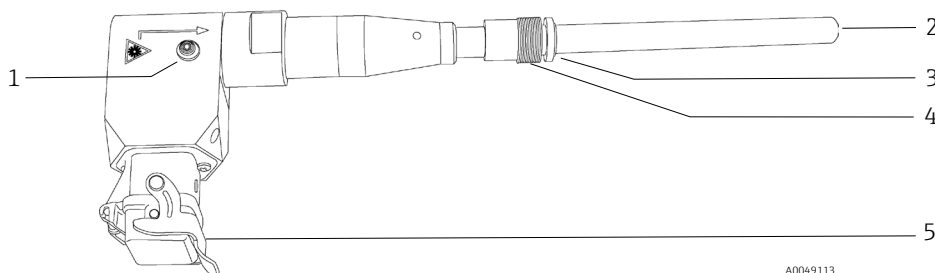

Figure 1. Rxn-45 probe

#	Name	Description
1	Laser interlock indicator light	Illuminated when there is potential for the laser to be energized
2	Probe tip	Tip of probe for sample interface; 120 mm (4.73 in) immersion length
3	Flange and o-ring	Welded flange and replaceable USP Class VI o-ring to ensure a tight seal with the vessel port/hardware
4	Captive nut	PG13.5 thread for industry standard sensor housings; welded port connectors available
5	Fiber-optic cable connector	Electro-optical (EO) fiber connection under spring-loaded fiber connector cap

Installation

During installation, standard eye and skin safety precautions for Class 3B laser products (as per EN 60825/IEC 60825-14) should be observed. Additionally, observe the following:

⚠ WARNING	<p>Standard precautions for laser products should be observed.</p> <ul style="list-style-type: none"> ▶ Probes should always be capped or pointed away from people toward a diffuse target if not installed in a sample chamber.
⚠ CAUTION	<p>The laser input into the probe must not exceed 499 mW.</p> <p>If stray light is allowed to enter an unused probe, it will interfere with data collected from a used probe and may cause calibration failure or measurement errors.</p> <ul style="list-style-type: none"> ▶ Unused probes should ALWAYS be capped to prevent stray light from entering the probe.
NOTICE	<p>When installing the probe <i>in situ</i>, the user must provide the strain relief to the fiber-optic cable at the probe installation location.</p>

Data collection zone: short

All versions of the Rxn-45 probe utilize short data collection zones. The short data collection zone maximizes spectral reproducibility by minimizing the impact of sample opacity, sample color, and transient particulates on the measured Raman spectrum.

Specifications

General specifications

General specifications for the Rxn-45 probe are listed below.

Note: Max service pressure ratings do not include the ratings of any fittings or flanges used to mount the probe into the process system. These items need to be independently evaluated and may lower the maximum service pressure of the probe.

Item	Description	
Laser wavelength	785 nm or 993 nm	
Spectral coverage	probe spectral coverage is limited by the coverage of the analyzer being used	
Maximum laser power into probe	< 499 mW	
Relative humidity	Up to 95 %, non-condensing	
Maximum service pressure (at tip)	13.8 barg (200 psig)	
Process connection	PG13.5 thread for industry standard sensor housings; welded port connectors available	
IEC 60529 rating	IP-65	
Depth of field	0.33 mm (0.013 in) FWHM	
Chemical resistance	limited by materials of construction	
Sterilization protocol compatibility	SIP/CIP	
Probe temperature	window, at tip	-30 to 150 °C (-22 to 302 °F)
	probe body	up to 150 °C (302 °F)
	temperature ramp	≤ 30 °C/min (≤ 54 °F/min)
Probe measurements	immersion length	120 mm (4.73 in)
	diameter	12 mm (0.48 in)
	dimensions (with EO connector cap open)	306 x 127 x 34 mm (12.05 x 5.0 x 1.34 in)
Materials of construction	probe body	316L stainless steel
	window	Proprietary material, optimized for bioprocesses
wetted, in contact with sample	adhesive	USP Class VI and ISO993 compatible
	surface finish	Ra 0.38 μm (Ra 15 μin) with electropolish
	fiber-optic cable	design: PVC jacketed, proprietary construction connections: proprietary electro-optic (EO) or FC to EO fiber converter(s) for non-embedded systems
Fiber-optic cable (cable sold separately)	length	EO cable available in 5 m (16.4 ft.) increments up to 200 m (656.2 ft.), with the length limited by the application
	minimum bend radius	152.4 mm (6 in)
	temperature	-40 to 70 °C (-40 to 158 °F)
	Flame resistance	certified: CSA-C/US AWM I/II, A/B, 80C, 30V, FT1, FT2, VW-1, FT4 rated: AWM I/II A/B 80C 30V FT4

Probe dimensions

The dimensions for the Rxn-45 probe are shown below.

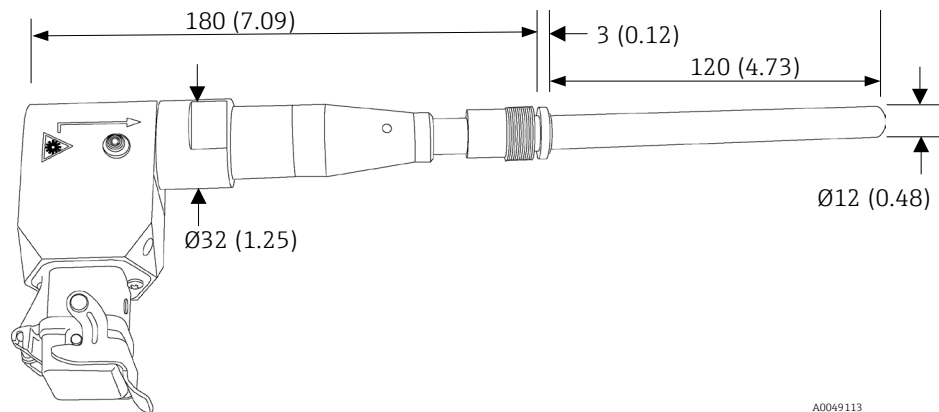

Figure 2. Rxn-45 probe. Dimensions: mm (in)

MPE : ocular exposure

Refer to the tables below from the ANSI Z136.1 standard to calculate the maximum permissible exposure (MPE) for point source ocular exposure to a laser beam.

A correction factor (C_A) may also be required and can be determined below.

Wavelength λ (nm)	Correction Factor C_A
400 to 700	1
700 to 1050	$10^{0.002(\lambda-700)}$
1050 to 1400	5

MPE for point source ocular exposure to a laser beam				
Wavelength λ (nm)	Exposure duration t (s)	MPE calculation		MPE where $C_A = 1.4791$
		(J·cm ⁻²)	(W·cm ⁻²)	
785 and 993	10^{-13} to 10^{-11}	$1.5 C_A \times 10^{-8}$	-	2.2×10^{-8} (J·cm ⁻²)
	10^{-11} to 10^{-9}	$2.7 C_A t^{0.75}$	-	Insert time (t) and calculate
	10^{-9} to 18×10^{-6}	$5.0 C_A \times 10^{-7}$	-	7.40×10^{-7} (J·cm ⁻²)
	18×10^{-6} to 10	$1.8 C_A t^{0.75} \times 10^{-3}$	-	Insert time (t) and calculate
	10 to 3×10^4	-	$C_A \times 10^{-3}$	1.4971×10^{-3} (W·cm ⁻²)

MPE: skin exposure

Refer to the table below from the ANSI Z136.1 standard to calculate the MPE for skin exposure to a laser beam.

MPE for skin exposure to a laser beam				
Wavelength λ (nm)	Exposure duration t (s)	MPE calculation		MPE where $C_A = 1.4791$
		(J·cm ⁻²)	(W·cm ⁻²)	
785 and 993	10 ⁻⁹ to 10 ⁻⁷	2 $C_A \times 10^{-2}$	-	2.9582 × 10 ⁻² (J·cm ⁻²)
	10 ⁻⁷ to 10	1.1 $C_A t^{0.25}$	-	Insert time (t) and calculate
	10 to 3 × 10 ⁴	-	0.2 C_A	2.9582 × 10 ⁻¹ (W·cm ⁻²)

www.addresses.endress.com
