

Technical Information

Levelflex FMP55

Guided-wave radar

Interface measurement in liquids



Application

- Rod, rope or coaxial probe
- Process connection: flange
- Process temperature: -50 to +200 °C (-58 to +392 °F)
- Process pressure: -1 to +40 bar (-14.5 to +580 psi)
- Maximum measuring range: rod 4 m (13 ft); rope 10 m (33 ft); coaxial 6 m (20 ft)
- Accuracy: ±2 mm (±0.08 in)
- International explosion protection certificates; marine approval; EN10204-3.1
- Linearity protocol (3-point, 5-point)

Your benefits

- Reliable measurement even in variable product and process conditions
- Integrated data memory
- Maximum reliability thanks to multi-echo tracking
- SIL2 as per IEC 61508, SIL3 for homogeneous redundancy
- Intuitive user interface in local language
- *Bluetooth*[®] wireless technology for commissioning, operation and maintenance
- Easy proof testing for SIL
- Heartbeat Technology™

Table of contents

Important document information	3	Process pressure range	37
Symbols	3	Relative permittivity and conductivity	37
		Extension of the rope probe	37
Function and system design	4	Mechanical construction	38
Measuring principle	4	Dimensions	38
Measuring system	7	Probe length tolerances	42
		Weight	42
Input	8	Materials	43
Measured variable	8	Operability	46
Measurement range	8	Operation concept	46
Blocking distance	8	Access to operating menu via local display	48
Measuring frequency spectrum	9	Access to the operating menu via the operating tool	49
		Integration in tank gauging	52
Output	9	SupplyCare	53
Output signal	9	Certificates and approvals	55
Signal on alarm	11	CE mark	55
Linearization	11	RoHS	55
Galvanic isolation	11	RCM marking	56
Protocol-specific data	11	Ex-approval	56
		Dual seal ANSI/ISA 12.27.01	56
Power supply	15	Functional safety	56
Terminal assignment	15	AD2000	56
Device plug	21	NACE MR 0175 / ISO 15156	56
Supply voltage	22	NACE MR 0103	56
Power consumption	24	ASME B31.1 and B31.3	56
Current consumption	24	Pressure Equipment Directive	56
Power supply failure	25	Marine approval	57
Potential equalization	25	Radio approval	57
Terminals	25	CRN approval	57
Cable entries	25	Test, certificate	57
Cable specification	25	Product documentation on paper	58
Overvoltage protection	26	External standards and guidelines	58
		Ordering information	58
Performance characteristics	26	3-point linearity protocol	58
Reference conditions	26	5-point linearity protocol	59
Reference accuracy	27	Customer-specific configuration	60
Resolution	29	Labeling (optional)	61
Response time	29	Application packages	61
Influence of ambient temperature	29	Heartbeat Diagnostics	61
		Heartbeat Verification	61
Installation	29	Heartbeat Monitoring	62
Mounting requirements	29	Accessories	63
		Device-specific accessories	63
Environment	34	Communication-specific accessories	69
Ambient temperature	34	Service-specific accessories	70
Ambient temperature limits	34	System components	70
Storage temperature	36	Documentation	71
Climate class	36		
Operating height	36		
Degree of protection	36		
Vibration resistance	36		
Cleaning the probe	36		
Electromagnetic compatibility (EMC)	36		
Process	37		
Process temperature range	37		

Important document information

Symbols

Safety symbols



This symbol alerts you to a dangerous situation. Failure to avoid this situation will result in serious or fatal injury.



This symbol alerts you to a dangerous situation. Failure to avoid this situation can result in serious or fatal injury.



This symbol alerts you to a dangerous situation. Failure to avoid this situation can result in minor or medium injury.



This symbol contains information on procedures and other facts which do not result in personal injury.

Electrical symbols



Direct current



Alternating current



Direct current and alternating current



Ground connection

A grounded terminal which, as far as the operator is concerned, is grounded via a grounding system.



Protective earth (PE)

Ground terminals that must be connected to ground prior to establishing any other connections. The ground terminals are located on the inside and outside of the device.

- Inner ground terminal; protective earth is connected to the mains supply.
- Outer ground terminal; device is connected to the plant grounding system.

Symbols for certain types of information and graphics



Procedures, processes or actions that are permitted

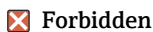

Procedures, processes or actions that are forbidden



Indicates additional information



Reference to documentation



Reference to graphic



Notice or individual step to be observed

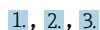

Series of steps



Result of a step

1, 2, 3, ...

Item numbers

A, B, C, ...

Views



Temperature resistance of the connection cables

Specifies the minimum value of the temperature resistance of the connection cables

Function and system design

Measuring principle

General principles

The Levelflex is a "downward-looking" measuring system that functions according to the ToF method (ToF = Time of Flight). The distance from the reference point to the product surface is measured. High-frequency pulses are injected to a probe and led along the probe. The pulses are reflected by the product surface, received by the electronic evaluation unit and converted into level information. This method is also known as time domain reflectometry (TDR).

In interface measurement, this method is combined with capacitance measurement.

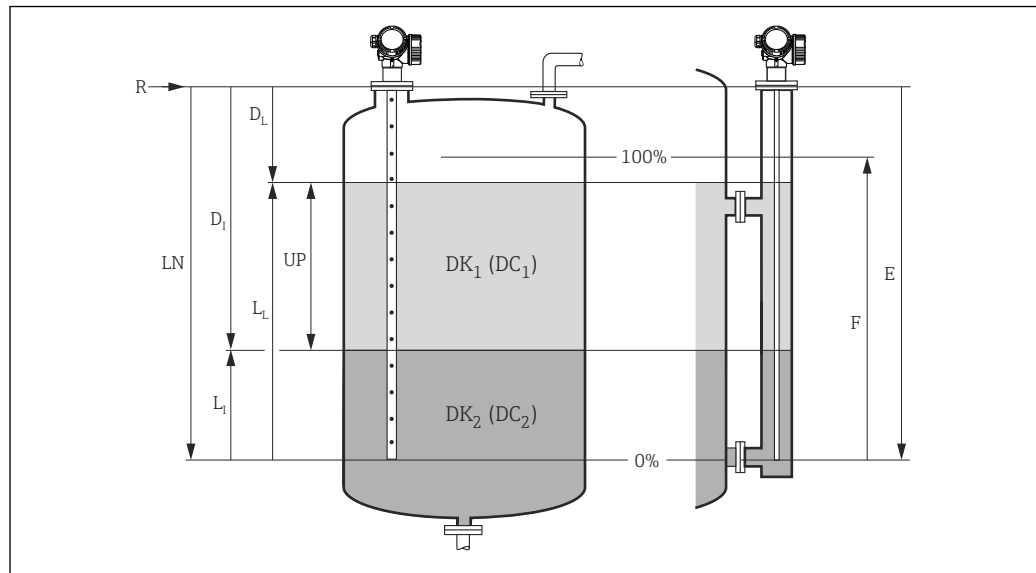

1 Parameters for level and interface measurement with the guided-wave radar

- R Reference point of measurement
- E Empty calibration (= zero)
- F Full calibration (= span)
- LN Length of probe
- UP Thickness of upper medium
- DL Total distance to level
- LI Total level
- DI Distance to interface (distance from flange to DC_2)
- LI Interface level (distance from probe end to DC_1)
- DC_1 Relative permittivity of upper medium
- DC_2 Relative permittivity of lower medium

i The reference point **R** of the measurement is located at the process connection.

Relative permittivity

The relative permittivity (ϵ_r) of the medium directly affects the degree of reflection of the high-frequency pulses. In the case of a large ϵ_r , such as with water or ammonia, there is strong pulse reflection. Conversely, if the ϵ_r is low, such as with hydrocarbons, pulse reflection is weak.

Input

The reflected pulses are transmitted from the probe to the electronics. Here, a microprocessor evaluates the signals and identifies the level echo which was caused by the reflection of the high-frequency pulses at the product surface. This clear signal detection system benefits from over 30 years of experience with pulse time-of-flight procedures that have gone into the development of the PulseMaster® software.

The distance D to the product surface is proportional to the time-of-flight t of the pulse:

$$D = c \cdot t/2,$$

where c is the speed of light.

Based on the known empty distance E, the level L is calculated:

$$L = E - D$$

The Levelflex includes user-activated functions for filtering out interference echos (mapping). These functions guarantee that interference echoes from internal fixtures and struts are not interpreted as level echoes.

Output

The Levelflex is preadjusted at the factory to the probe length ordered so that in most cases only the application parameters that automatically adapt the device to the measuring conditions need to be entered. For models with a current output, the factory adjustment for zero point E and span F is 4 mA and 20 mA, for digital outputs and the display module 0 % and 100 %. A linearization function with max. 32 points, which is based on a table entered manually or semi-automatically, can be activated on site or via remote operation. This function allows the level to be converted into units of volume or mass, for example.

Interface measurement

When the high-frequency pulses hit the surface of the medium, only a percentage of the transmission pulse is reflected. In the case of medium with a low DK_1 , in particular, the other part enters the medium. The pulse is reflected once more at the interface point to a second medium with a higher DK_2 . The distance to the interface layer can now also be determined, taking into account the delayed time-of-flight of the pulse through the upper medium.

In addition, FMP55 measures the capacitance of the probe. This means that interface measurements can still be obtained even if emulsions form between the two media, resulting in the lack of a second reflection signal.

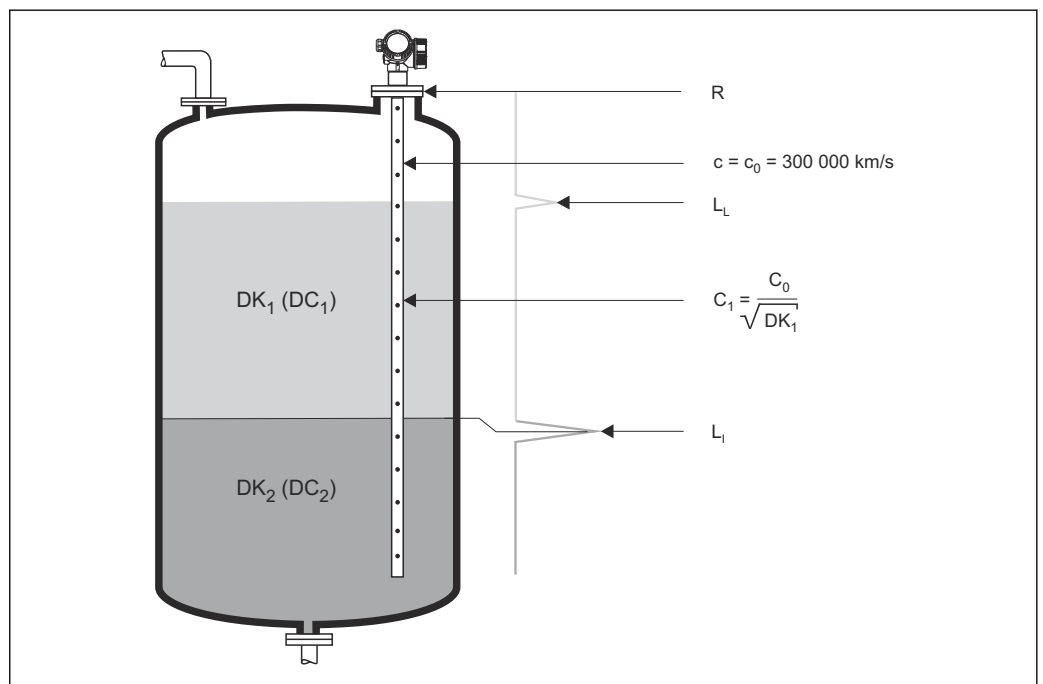

A0011178

2 Interface measurement with the guided-wave radar

- LL Total level
- LI Interface level
- R Reference point of measurement

In addition, the following general conditions must be observed for interface measurement:

- The relative permittivity of the upper medium must be known and constant. The relative permittivity can be determined using the DC Manual CP00019F or with the "DC Values App" (DC=dielectric constant). Furthermore, if the interface thickness is available and known, the relative permittivity can be calculated automatically in FieldCare.
- The relative permittivity of the upper medium may not exceed 10.
- The relative permittivity difference between the upper and lower medium must be >10 .
- The minimum thickness of the upper medium is 60 mm (2.4 in).

 For the relative permittivity values (ϵ_r values) of many media commonly used in industry, please refer to:

- Relative permittivity (ϵ_r value), Compendium CP01076F
- The Endress+Hauser "DC Values app" (available for Android and iOS)

When using the capacitive measurement of the FMP55:

- Conductivity of the upper medium: $< 1 \mu\text{S/cm}$
- Conductivity of the lower medium: $> 100 \mu\text{S/cm}$

Product life cycle

Planning

- Universal measuring principle
- Measurement unaffected by medium properties
- Hardware and software developed according to SIL IEC61508
- Genuine, direct interface measurement

Procurement

- As the global market leader in level measurement, Endress+Hauser guarantees the security of your investment
- Worldwide support and service

Installation

- No special tools are required
- Protection against reverse polarity
- Modern, detachable terminals
- Main electronics protected by a separate connection compartment

Commissioning

- Fast, menu-guided commissioning in just 6 steps
- Plain text display in local language reduces the risk of error or confusion
- Direct local access to all parameters
- Printed Brief Operating Instructions in the device onsite

Operation

- Redundant measurement for maximum measurement reliability, thanks to SensorFusion
- Multi-echo tracking: Reliable measurement thanks to self-learning echo search algorithms taking into account the short-term and long-term history and plausibility of the detected signals to suppress interference echoes.
- In accordance with NAMUR NE107

Maintenance

- HistoROM: Data backup for device settings and measured values
- Exact device and process diagnostics to assist fast decisions with clear information regarding remedial action
- Intuitive, menu-guided operating concept in local language saves costs for training, maintenance and operation
- Cover of the electronics compartment can also be opened in the hazardous area

Retirement

- Order code translation for subsequent models
- RoHS-compliant (Restriction of certain Hazardous Substances), unleaded soldering of electronic components
- Environmentally friendly recycling approach

Measuring system

General notes on probe selection

- For interface measurement, ideally coaxial probes or rod probes are used in the bypass/stilling well.
- Coaxial probes are suitable for liquids with a viscosity of up to approx. 500 cst. The vast majority of liquefied gases can be measured with coaxial probes, provided the $\epsilon_r > 1.4$. Furthermore, installation conditions, such as nozzles, internal fixtures in the tank etc., have no effect on the measurement when a coaxial probe is used. A coaxial probe offers maximum EMC safety when used in plastic tanks.
- Rod or rope probes are not recommended for free-space installation in the tank. Rope probes may also be used in the bypass/stilling well if the distance to the ceiling (clearance) is not sufficient for the installation of a rod probe and if contact between the rope/probe weight with the pipe wall can be ruled out (sufficient diameter, straight pipe).

Probe selection

FMP55

For level measurement and interface measurement in liquids

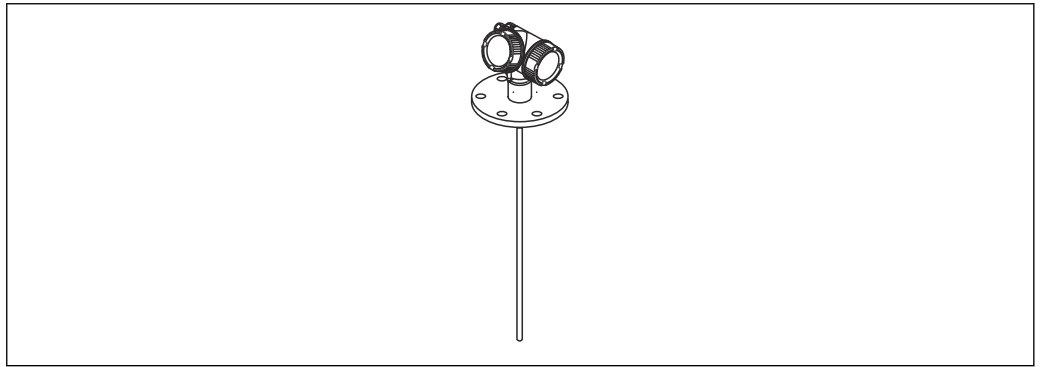

A0011357

3 Rod probe

Rod probe

- Maximum probe length 4 m (13 ft)
- Material PFA > 316 L

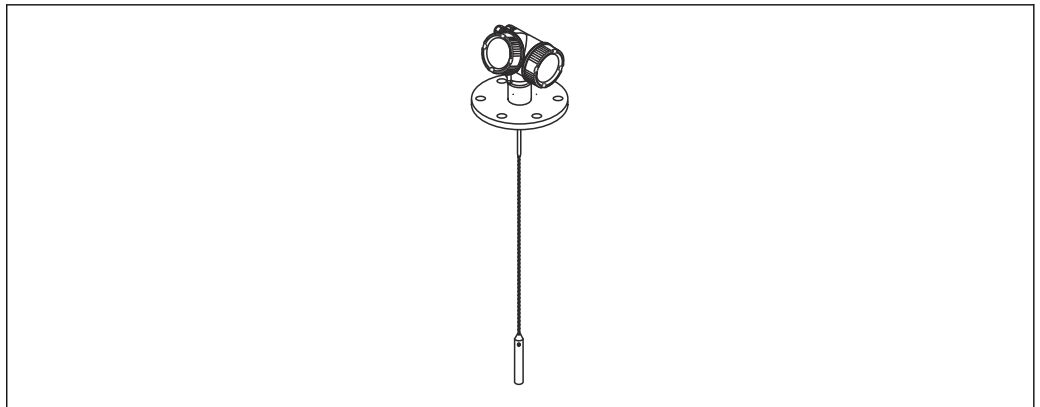

A0011358

4 Rope probe with centering rod

Rope probe

- Maximum probe length 10 m (33 ft)
- Material PFA > 316 L

i If the version with the remote probe is used, the maximum probe length that can be ordered is 7 m (23 ft).

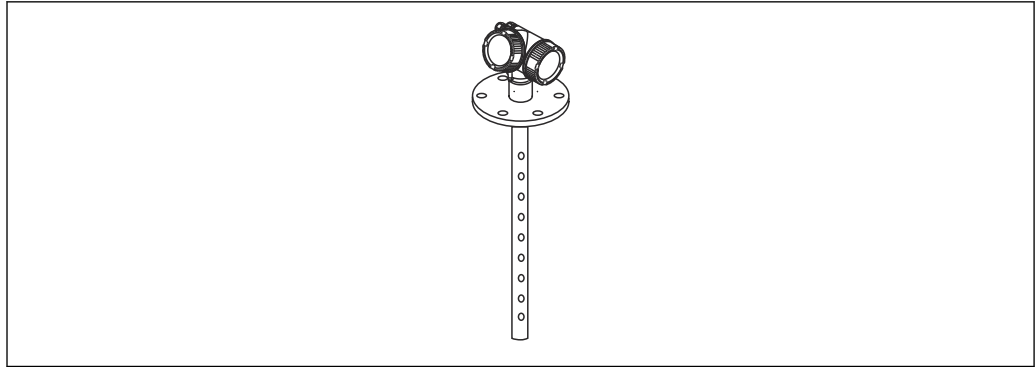

A0011359

 5 Coaxial probe

Coaxial probe

- Maximum probe length 6 m (20 ft)
- Material 316 L, multiple holes

Input

Measured variable	<p>The measured variable is the distance between the reference point and the product surface.</p> <p>The level is calculated based on E, the empty distance entered.</p> <p>Optionally, the level can be converted to other variables (volume, mass) by linearization (32 points).</p>
Measurement range	<p>The maximum measuring range is:</p> <ul style="list-style-type: none"> ▪ up to 10 m (33 ft) for rope probe in the bypass or stilling well ▪ up to 4 m (13 ft) for rod probe in the bypass or stilling well ▪ up to 6 m (20 ft) for coaxial probe <p> The formation of buildup, particularly of moist products, can reduce the maximum possible measuring range.</p> <ul style="list-style-type: none"> ▪ Due to the high diffusion rate of ammonia, a gas-tight gland (optional) is recommended for measurements in this medium.
Blocking distance	<p>The upper blocking distance UB is the minimum distance from the reference point R of the measurement to the maximum level.</p>

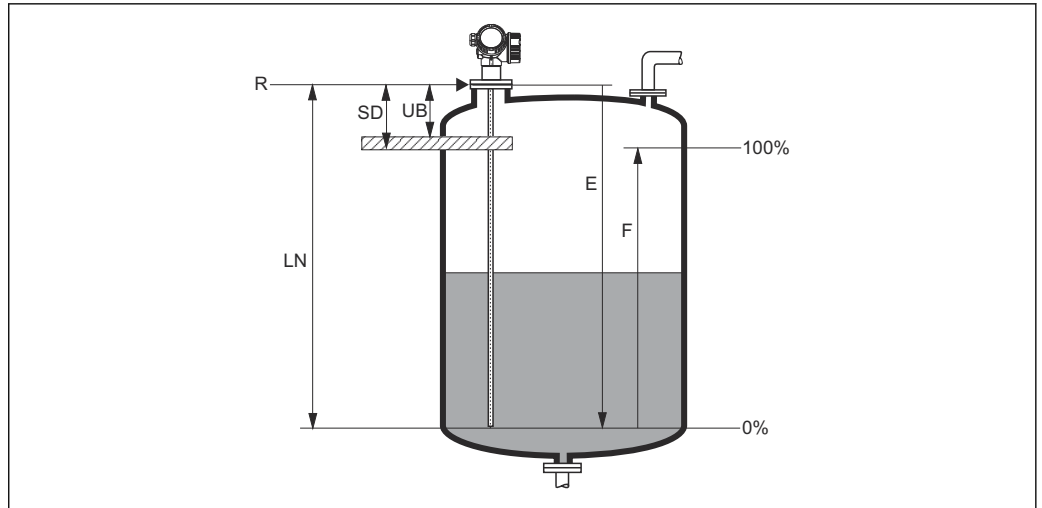

A0011279

6 Definition of blocking distance and safety distance

- R Reference point of measurement
- LN Length of probe
- UB Upper blocking distance
- E Empty calibration (zero)
- F Full calibration (span)
- SD Safety distance

Blocking distance (factory setting):

- For coaxial probes: 0 mm (0 in)
- For rod and rope probes up to 8 m (26 ft): 200 mm (8 in)
- For rod and rope probes over 8 m (26 ft): $0.025 \times \text{probe length}$

i The specified blocking distances are factory-preset on delivery. These settings can be changed depending on the application.

A reliable measurement cannot be guaranteed within the blocking distance.

i A safety distance **SD** can be defined in addition to the blocking distance. The device generates a warning if the level rises to enter this safety distance.

Measuring frequency spectrum

100 MHz to 1.5 GHz

Output

Output signal

HART

- Signal coding: FSK ± 0.5 mA over current signal
- Data transmission rate: 1 200 Bit/s
- Galvanic isolation: Yes

Bluetooth® wireless technology

- Device version: Order code 610 "Accessory mounted", option NF "Bluetooth"
- Operation / configuration: Via the *SmartBlue* app
- Range under reference conditions: > 10 m (33 ft)
- Encryption: Encrypted communication and password encryption prevent incorrect operation by unauthorized persons

PROFIBUS PA

- Signal coding:
Manchester Bus Powered (MBP)
- Data transmission rate:
31.25 kBit/s, voltage mode
- Galvanic isolation:
Yes

FOUNDATION Fieldbus

- Signal coding:
Manchester Bus Powered (MBP)
- Data transmission rate:
31.25 kBit/s, voltage mode
- Galvanic isolation:
Yes

Switch output

For HART devices, the switch output is available as an option.

- Function:
Open collector switch output
- Switching behavior:
Binary (conductive or non-conductive), switches when the programmable switch-on point/switch-off point is reached
- Failure mode:
Non-conductive
- Electrical connection data:
 $U = 16 \text{ to } 35 \text{ V}_{\text{DC}}, I = 0 \text{ to } 40 \text{ mA}$
- Internal resistor:
 $R_i < 880 \Omega$
The voltage drop at this internal resistor must be taken into account when planning the configuration. For example, the resulting voltage at a connected relay must be sufficient to switch the relay.
- Insulation voltages:
Floating, insulation voltage $1\,350 \text{ V}_{\text{DC}}$ in relation to power supply and $500 \text{ V}_{\text{AC}}$ ground
- Switch point:
User-programmable, separate for switch-on point and switch-off point
- Switching delay:
User-programmable in the 0 to 100 s range, separate for switch-on point and switch-off point
- Scan rate:
Corresponds to the measuring cycle
- Signal source / device variables:
 - Level linearized
 - Distance
 - Terminal voltage
 - Electronic temperature
 - Relative echo amplitude
 - Diagnostic values, advanced diagnostic blocks
 - Only for active interface measurement
- Signal source / device variables for active interface measurement:
 - Interface linearized
 - Interface distance
 - Upper interface distance
 - Relative interface amplitude
- Number of switch cycles:
Unlimited

Signal on alarm	<p>Depending on the interface, failure information is displayed as follows:</p> <ul style="list-style-type: none"> ■ Current output <ul style="list-style-type: none"> ■ Choice of failure mode (in accordance with NAMUR Recommendation NE 43): <ul style="list-style-type: none"> Minimum alarm: 3.6 mA Maximum alarm (= factory setting): 22 mA ■ Failure mode with user-configurable value: 3.59 to 22.5 mA ■ Local display <ul style="list-style-type: none"> ■ Status signal (as per NAMUR Recommendation NE 107) ■ Plain text display ■ Operating tool via digital communication (HART, PROFIBUS PA, FOUNDATION Fieldbus) or service interface (CDI) <ul style="list-style-type: none"> ■ Status signal (as per NAMUR Recommendation NE 107) ■ Plain text display
Linearization	<p>The device's linearization function allows the user to convert the measured value to any length or volume units. Linearization tables for calculating the volume in cylindrical vessels are preprogrammed into the device. Other tables of up to 32 value pairs can be entered manually or semi-automatically.</p>
Galvanic isolation	<p>All circuits for the outputs are galvanically isolated from each other.</p>
Protocol-specific data	<p>HART</p> <p>Manufacturer ID: 17 (0x11{hex})</p> <p>Device type ID: 0x1122</p> <p>HART specification: 7</p> <p>Device description files (DTM, DD) Information and files available at:</p> <ul style="list-style-type: none"> ■ www.endress.com On the product page for the device: Documents/Software → Device drivers ■ www.fieldcommgroup.org <p>HART load: Min. 250 Ω</p> <p><i>HART device variables</i></p> <p>The measured values can be freely assigned to the device variables.</p> <p>Measured values for PV (primary variable)</p> <ul style="list-style-type: none"> ■ Level linearized ■ Distance ■ Interface ■ Interface distance ■ Upper interface thickness ■ Electronics temperature ■ Measured capacitance ■ Relative echo amplitude ■ Relative interface amplitude <p>Measured values for SV, TV, QV (second, third and fourth variable)</p> <ul style="list-style-type: none"> ■ Level linearized ■ Distance ■ Interface linearized ■ Interface distance ■ Terminal voltage ■ Electronics temperature ■ Measured capacitance ■ Absolute echo amplitude ■ Relative echo amplitude ■ Absolute interface amplitude ■ Relative interface amplitude ■ Calculated ϵ_r value

Supported functions

- Burst mode
- Additional transmitter status

Wireless HART data**Minimum start-up voltage:**

17.5 V

Start-up current:

4 mA

Starting time:

80 s

Minimum operating voltage:

17.5 V

Multidrop current:

4.0 mA

Time to establish connection:

30 s

PROFIBUS PA**Manufacturer ID:**

17 (0x11)

Ident number:

0x1568 or 0x9700

Profile version:

3.02

GSD file and version

Information and files available at:

- www.endress.com
On the product page for the device: Documents/Software → Device drivers
- www.profibus.com

*Output values***Analog Input:**

- Level linearized
- Distance
- Interface
- Interface distance
- Upper interface thickness
- Terminal voltage
- Electronics temperature
- Measured capacitance
- Absolute echo amplitude
- Relative echo amplitude
- Absolute interface amplitude
- Relative interface amplitude
- Calculated ϵ_r value

Digital Input:

- Extended diagnostic blocks
- Status output PFS Block

*Input values***Analog Output:**

- Analog value from PLC (for sensor block, external pressure and temperature)
- Analog value from PLC to be indicated on the display

Digital Output:

- Extended diagnostic block
- Level Limiter
- Sensor Block Measurement On
- Sensor Block Save History On
- Status output

Supported functions

- Identification & Maintenance
Straightforward device identification on the part of the control system and nameplate
- Automatic Ident Number Adoption
GSD compatibility mode for generic profile 0x9700 "Transmitter with 1 Analog Input"
- Physical Layer Diagnostics
Installation check of the PROFIBUS segment and device using terminal voltage and message monitoring
- PROFIBUS Upload/download
Reading and writing parameters is up to ten times faster with PROFIBUSupload/download
- Condensed Status
Straightforward and self-explanatory diagnostic information by categorizing diagnostic messages that occur

FOUNDATION Fieldbus

Manufacturer ID	0x452B48
Device type	0x1028
Device revision	0x01
DD revision	Information and files available at: <ul style="list-style-type: none"> ■ www.endress.com ■ www.fieldcommgroup.org
CFF revision	
Device Tester Version (ITK version)	6.0.1
ITK Test Campaign Number	IT085300
Link Master capability (LAS)	Yes
Choice of "Link Master" and "Basic Device"	Yes; factory setting: Basic Device
Node address	Factory setting: 247 (0xF7)
Supported functions	The following methods are supported: <ul style="list-style-type: none"> ■ Restart ■ ENP Restart ■ Setup ■ Linearization ■ Self Check
Virtual Communication Relationships (VCRs)	
Number of VCRs	44
Number of link objects in VFD	50
Permanent entries	1
Client VCRs	0
Server VCRs	10
Source VCRs	43
Sink VCRs	0
Subscriber VCRs	43
Publisher VCRs	43
Device Link Capabilities	
Slot time	4
Min. delay between PDU	8
Max. response delay	20

Transducer blocks

Block	Content	Output values
Setup Transducer Block	Contains all the parameters for standard commissioning	<ul style="list-style-type: none"> ■ Level or volume (channel 1) (depending on the block configuration) ■ Distance (channel 2)
Advanced Setup Transducer Block	Contains all the parameters for more accurate measurement configuration	No output values
Display Transducer Block	Contains parameters to configure the onsite display	No output values
Diagnostic Transducer Block	Contains diagnostic information	No output values
Advanced Diagnostic Transducer Block	Contains parameters for advanced diagnostics	No output values
Expert Configuration Transducer Block	Contains parameters that require the user to have in-depth knowledge of the operation of the device in order to configure the parameters appropriately	No output values
Expert Information Transducer Block	Contains parameters that provide information about the state of the device	No output values
Service Sensor Transducer Block	Contains parameters that can only be accessed by Endress+Hauser Service	No output values
Service Information Transducer Block	Contains parameters that provide Endress+Hauser Service with information about the state of the device	No output values
Data Transfer Transducer Block	Contains parameters for backing up the device configuration in the display module and for writing the saved configuration to the device. Access to these parameters is reserved for Endress+Hauser Service.	No output values

Function blocks

Block	Content	Number of permanent blocks	Number of instantiatable blocks	Execution time	Functionality
Resource Block	The Resource Block contains all the data that uniquely identify the device. It is an electronic version of a nameplate of the device.	1	0	-	Extended
Analog Input Block	The AI Block receives the measuring data from the Sensor Block (selectable via a channel number), and makes the data available to other blocks at its output.	2	3	25 ms	Extended
Discrete Input Block	The Discrete Input Block receives a discrete value (e.g. indicator that measuring range has been exceeded) and makes the value available for other blocks at the output.	1	2	20 ms	Standard
Multiple Analog Output Block	The Multiple Analog Output Block is used to transmit analog values from the bus to the device.	1	0	20 ms	Standard
Multiple Discrete Output Block	The Multiple Discrete Output Block is used to transmit discrete values from the bus to the device.	1	0	20 ms	Standard
PID Block	The PID Block is used as a proportional-integral-derivative controller and can be used universally for closed-loop-control in the field. It enables cascade mode and feedforward control.	1	1	25 ms	Standard
Arithmetic Block	This block is designed to enable the simple use of common mathematical functions in measuring technology. The user does not have to know how to write equations. The math algorithm is selected by name, chosen by the user for the function to be performed.	1	1	25 ms	Standard
Signal Characterizer Block	The Signal Characterizer Block has two sections, each with an output value that is a non-linear function of the input value. The non-linear function is generated by a single look-up table with 21 arbitrary x-y pairs.	1	1	25 ms	Standard

Block	Content	Number of permanent blocks	Number of instantiatable blocks	Execution time	Functionality
Input Selector Block	This block facilitates the selection of up to four inputs and generates an output value based on the configured action. This block normally receives its inputs from AI Blocks. The block enables the selection of maximum, minimum, average and 'first good' values.	1	1	25 ms	Standard
Integrator Block	The Integrator Block integrates a variable as a function of the time or accumulates the counts from a Pulse Input Block. The Block can be used as a totalizer that totalizes until a reset, or as a batch totalizer whereby the integrated value is compared against a target value generated before or during the control routine and generates a binary signal when the target value is reached.	1	1	25 ms	Standard
Analog Alarm Block		1	1	25 ms	Standard

 Up to 20 blocks can be instantiated in the device altogether, including the blocks already instantiated.

Power supply

Terminal assignment

Terminal assignment, 2-wire: 4 to 20 mA HART

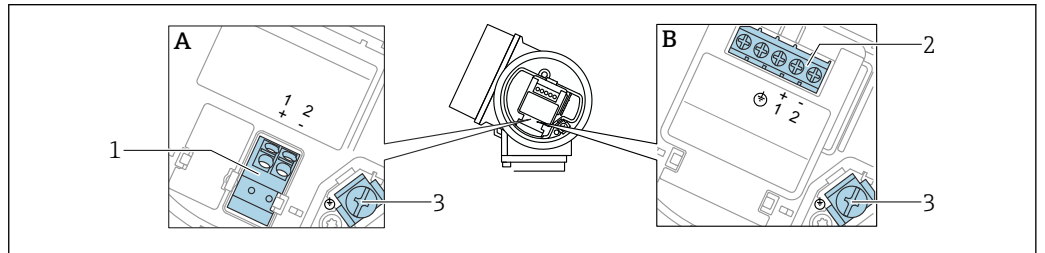

 7 Terminal assignment, 2-wire: 4 to 20 mA HART

A Without integrated overvoltage protection

B With integrated overvoltage protection

1 Connection 4 to 20 mA, HART passive: terminals 1 and 2, without integrated overvoltage protection

2 Connection 4 to 20 mA, HART passive: terminals 1 and 2, with integrated overvoltage protection

3 Terminal for cable shield

A0036498

Function diagram 4 to 20 mA HART

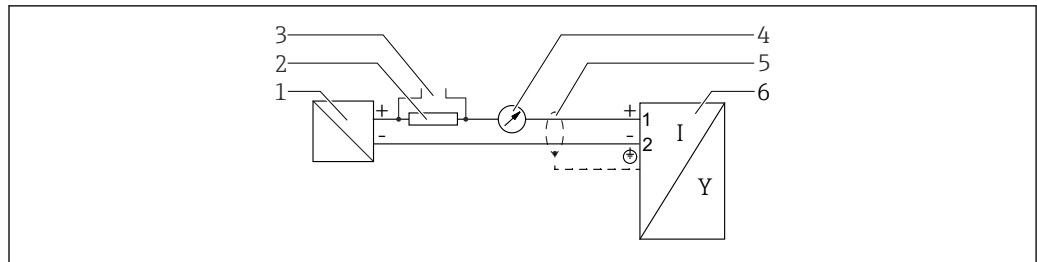

A0036499

8 Function diagram 4 to 20 mA HART

- 1 Active barrier for power supply; observe terminal voltage
- 2 Resistor for HART communication ($\geq 250 \Omega$); observe maximum load
- 3 Connection for Commubox FXA195 or FieldXpert (via VIATOR Bluetooth modem)
- 4 Analog display unit; observe maximum load
- 5 Cable screen; observe cable specification
- 6 Measuring instrument

Terminal assignment, 2-wire: 4 to 20 mA HART, switch output

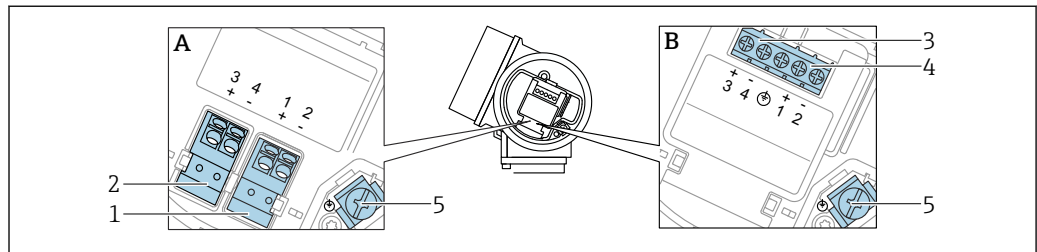

A0036500

9 Terminal assignment, 2-wire: 4 to 20 mA HART, switch output

- A Without integrated overvoltage protection
- B With integrated overvoltage protection
- 1 Connection 4 to 20 mA, HART passive: terminals 1 and 2, without integrated overvoltage protection
- 2 Connection, switch output (open collector): terminals 3 and 4, without integrated overvoltage protection
- 3 Connection, switch output (open collector): terminals 3 and 4, with integrated overvoltage protection
- 4 Connection 4 to 20 mA, HART passive: terminals 1 and 2, with integrated overvoltage protection
- 5 Terminal for cable shield

Function diagram 4 to 20 mA HART, switch output

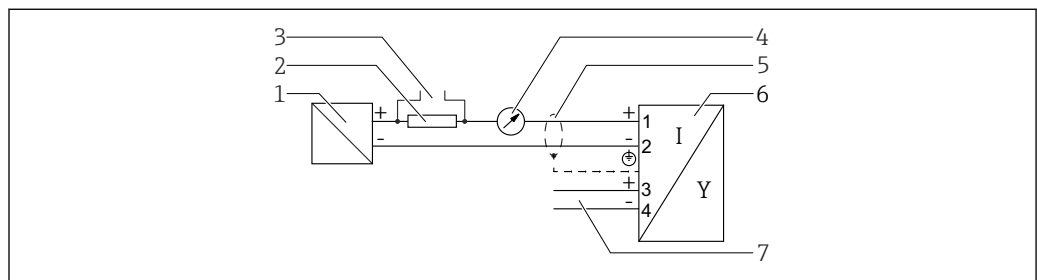

A0036501

10 Function diagram 4 to 20 mA HART, switch output

- 1 Active barrier for power supply; observe terminal voltage
- 2 Resistor for HART communication ($\geq 250 \Omega$); observe maximum load
- 3 Connection for Commubox FXA195 or FieldXpert (via VIATOR Bluetooth modem)
- 4 Analog display unit; observe maximum load
- 5 Cable screen; observe cable specification
- 6 Measuring instrument
- 7 Switch output (open collector)

Connection example of relay

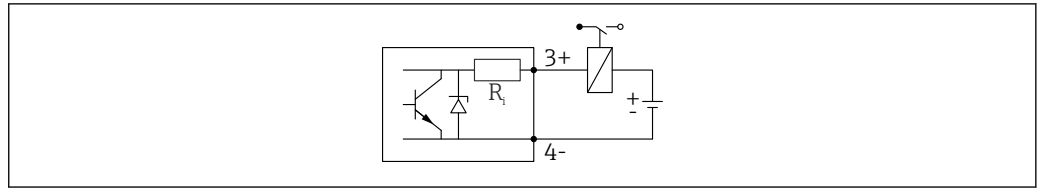

A0015909

11 Connection example of relay

Connection example for the digital input

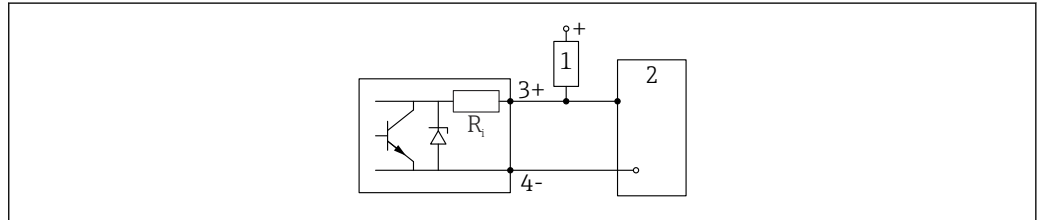

A0015910

12 Connection example for the digital input

- 1 Pull-up resistor
- 2 Digital input

Terminal assignment, 2-wire: 4 to 20 mA HART, 4 to 20 mA

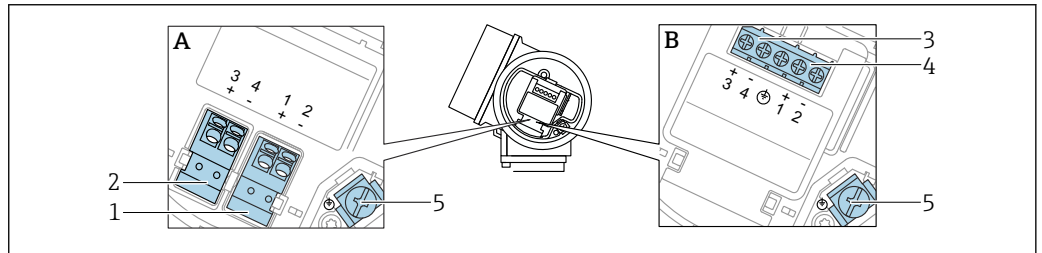

A0036500

13 Terminal assignment, 2-wire: 4 to 20 mA HART, 4 to 20 mA

- A Without integrated overvoltage protection
- B With integrated overvoltage protection
- 1 Connection current output 1, 4 to 20 mA HART passive: terminals 1 and 2, without integrated overvoltage protection
- 2 Connection current output 2, 4 to 20 mA: terminals 3 and 4, without integrated overvoltage protection
- 3 Connection current output 2, 4 to 20 mA: terminals 3 and 4, with integrated overvoltage protection
- 4 Connection current output 1, 4 to 20 mA HART passive: terminals 1 and 2, with integrated overvoltage protection
- 5 Terminal for cable shield

Function diagram 4 to 20 mA HART + 4 to 20 mA analog

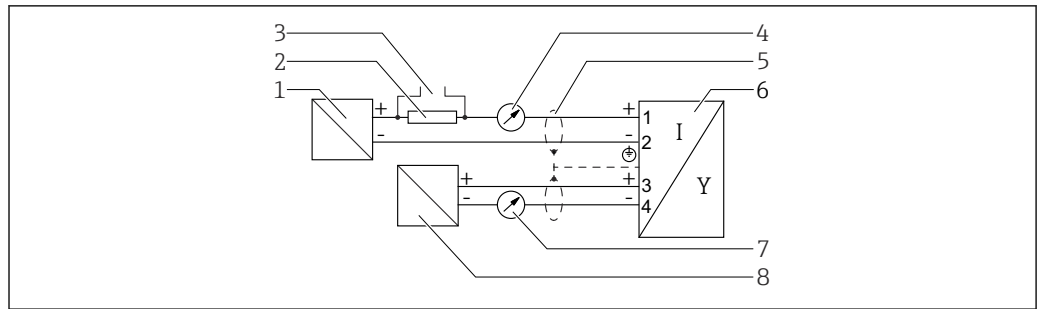

A0036502

14 Function diagram 4 to 20 mA HART + 4 to 20 mA analog

- 1 Active barrier for power supply, current output 1; observe terminal voltage
- 2 Resistor for HART communication ($\geq 250 \Omega$); observe maximum load
- 3 Connection for Commubox FXA195 or FieldXpert (via VIATOR Bluetooth modem)
- 4 Analog display unit; observe maximum load
- 5 Cable screen; observe cable specification
- 6 Measuring instrument
- 7 Analog display unit; observe maximum load
- 8 Active barrier for power supply, current output 2; observe terminal voltage

Terminal assignment, 4-wire: 4 to 20 mA HART (10.4 to 48 V_{DC})

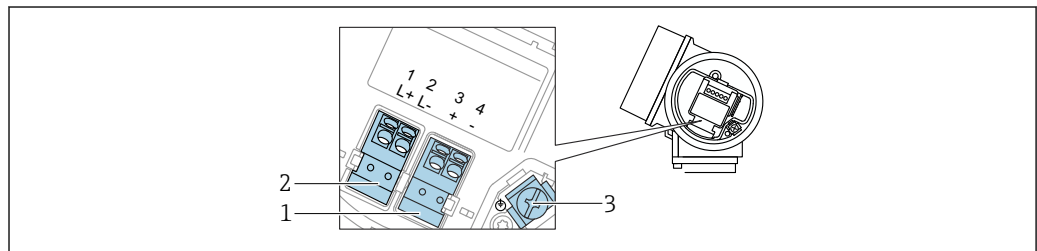

A0036516

15 Terminal assignment, 4-wire: 4 to 20 mA HART (10.4 to 48 V_{DC})

- 1 Connection 4 to 20 mA HART (active): terminals 3 and 4
- 2 Power supply connection: terminals 1 and 2
- 3 Terminal for cable shield

Function diagram 4-wire: 4 to 20 mA HART (10.4 to 48 V_{DC})

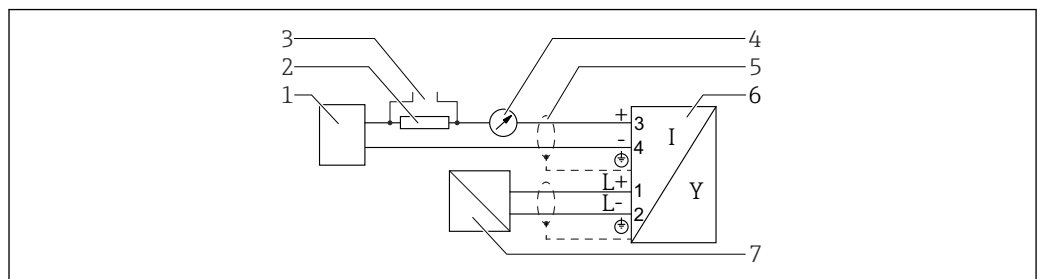

A0036526

16 Function diagram 4-wire: 4 to 20 mA HART (10.4 to 48 V_{DC})

- 1 Evaluation unit, e.g. PLC
- 2 Resistor for HART communication ($\geq 250 \Omega$); observe maximum load
- 3 Connection for Commubox FXA195 or FieldXpert (via VIATOR Bluetooth modem)
- 4 Analog display unit; observe maximum load
- 5 Cable screen; observe cable specification
- 6 Device
- 7 Supply voltage; observe terminal voltage, observe cable specification

Terminal assignment, 4-wire: 4 to 20 mA HART (90 to 253 V_{AC})

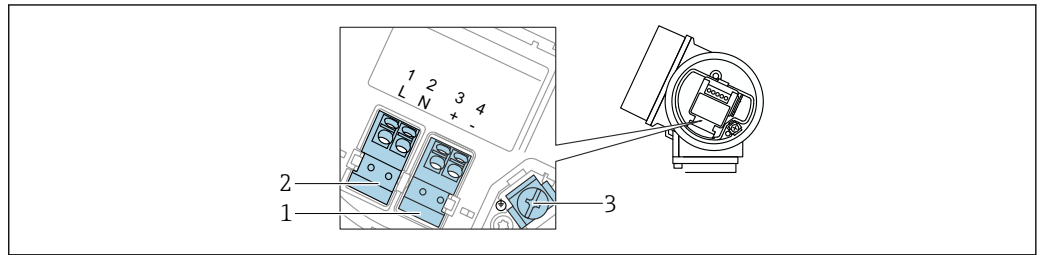

A0036519

17 Terminal assignment, 4-wire: 4 to 20 mA HART (90 to 253 V_{AC})

- 1 Connection 4 to 20 mA HART (active): terminals 3 and 4
- 2 Power supply connection: terminals 1 and 2
- 3 Terminal for cable shield

CAUTION

To ensure electrical safety:

- ▶ Do not disconnect the protective ground connection.
- ▶ Disconnect the device from the supply voltage before disconnecting the protective ground.
- i** Connect protective ground to the inner ground terminal (3) before connecting the power supply. If necessary, connect the potential matching line to the outer ground terminal.
- i** In order to ensure electromagnetic compatibility (EMC): do **not** ground the device exclusively via the protective ground conductor of the supply cable. Instead, the functional grounding must also be connected to the process connection (flange or threaded connection) or to the external ground terminal.
- i** An easily accessible power switch must be installed in the proximity of the device. The switch must be marked as a disconnecter for the device (61010IEC/).

Function diagram 4-wire: 4 to 20 mA HART (90 to 253 V_{AC})

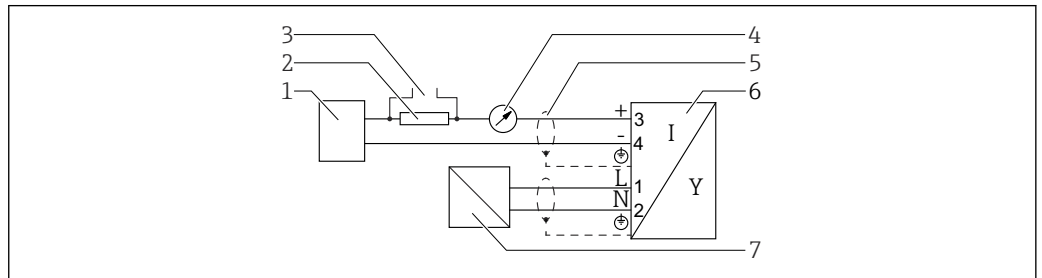

A0036527

18 Function diagram 4-wire: 4 to 20 mA HART (90 to 253 V_{AC})

- 1 Evaluation unit, e.g. PLC
- 2 Resistor for HART communication ($\geq 250 \Omega$); observe maximum load
- 3 Connection for Commubox FXA195 or FieldXpert (via VIATOR Bluetooth modem)
- 4 Analog display unit; observe maximum load
- 5 Cable screen; observe cable specification
- 6 Device
- 7 Supply voltage; observe terminal voltage, observe cable specification

Terminal assignment PROFIBUS PA / FOUNDATION Fieldbus

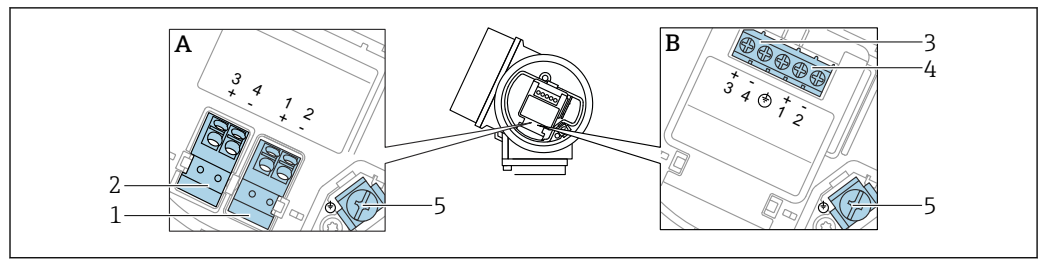

A0036500

19 Terminal assignment PROFIBUS PA / FOUNDATION Fieldbus

A Without integrated overvoltage protection

B With integrated overvoltage protection

1 Connection, PROFIBUS PA / FOUNDATION Fieldbus: terminals 1 and 2, without integrated overvoltage protection

2 Connection, switch output (open collector): terminals 3 and 4, without integrated overvoltage protection

3 Connection, switch output (open collector): terminals 3 and 4, with integrated overvoltage protection

4 Connection, PROFIBUS PA / FOUNDATION Fieldbus: terminals 1 and 2, with integrated overvoltage protection

5 Terminal for cable shield

Block view PROFIBUS PA / FOUNDATION Fieldbus

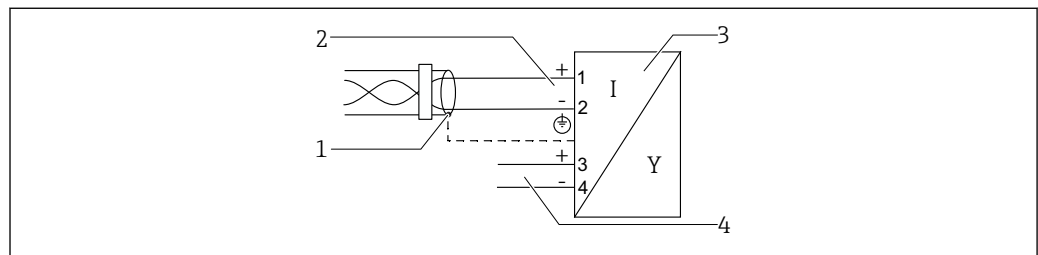

A0036530

20 Block view PROFIBUS PA / FOUNDATION Fieldbus

1 Cable screen; observe cable specification

2 Connection PROFIBUS PA / FOUNDATION Fieldbus

3 Measuring instrument

4 Switch output (open collector)

HART loop converter HMX50

The dynamic variables of the HART protocol can be converted into individual 4 to 20 mA sections using the HART loop converter HMX50. The variables are assigned to the current output and the measuring ranges of the individual parameters are defined in the HMX50.

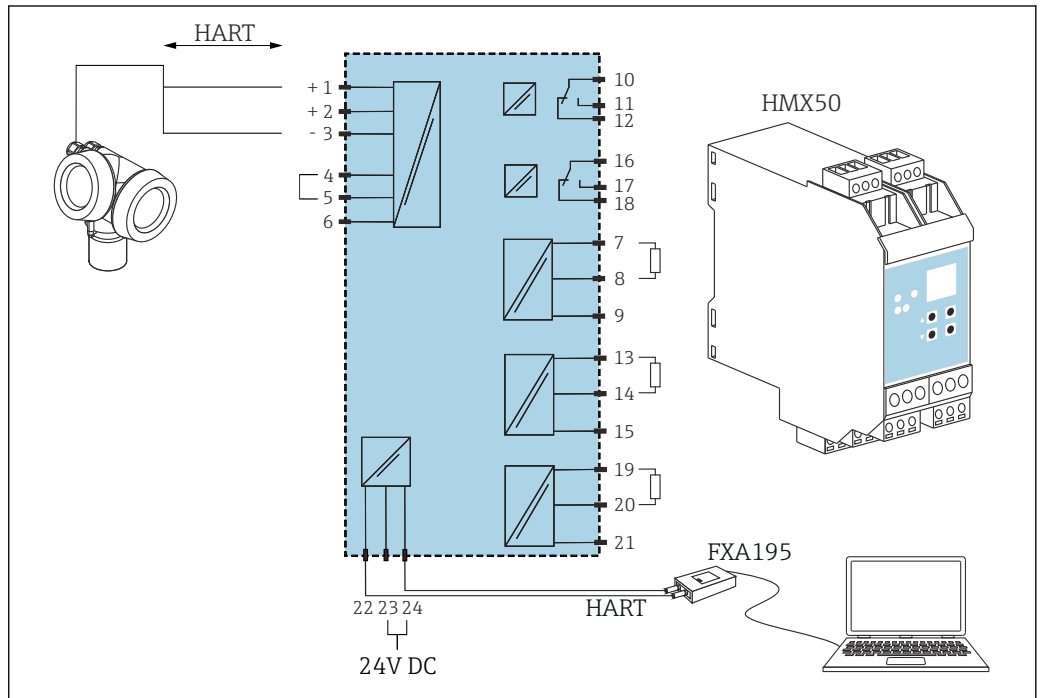

A0023287

21 Connection diagram for HART loop converter HMX50 (example: passive 2-wire device and current outputs connected as power source)

The HART loop converter HMX50 can be acquired using the order number 71063562.

Additional documentation: TI00429F and BA00371F.

Device plug

In the case of the device versions with a plug, the housing does not need to be opened to connect the signal cable.

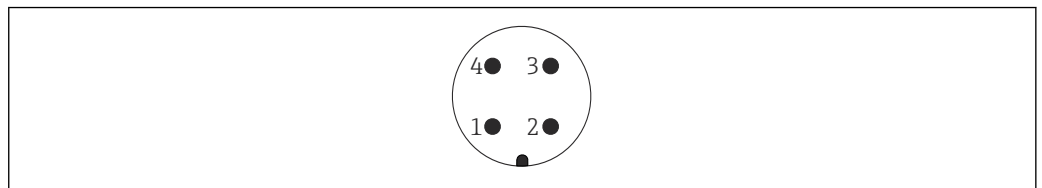

A0011175

22 Pin assignment of M12 plug

- 1 Signal +
- 2 Not assigned
- 3 Signal -
- 4 Ground

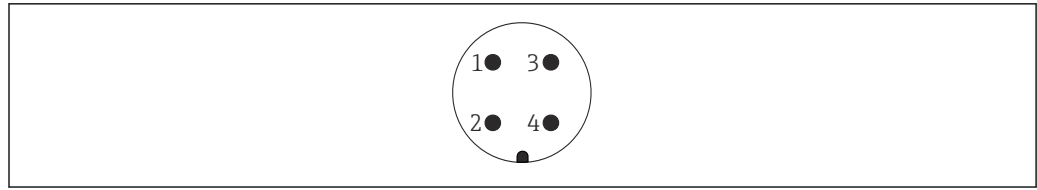

A0011176

23 Pin assignment of 7/8" plug

- 1 Signal -
- 2 Signal +
- 3 Not assigned
- 4 Shielding

Supply voltage

An external power supply is necessary.

 Various power supply units can be ordered from Endress+Hauser.

2-wire, 4-20mA HART, passive

2-wire; 4-20mA HART¹⁾

"Approval" ²⁾	Terminal voltage U at device	Maximum load R, depending on the supply voltage U ₀ of the power supply unit
<ul style="list-style-type: none"> ▪ Non-hazardous ▪ Ex nA ▪ Ex ic ▪ CSA GP 	17.5 to 35 V ³⁾	<p>The graph shows the maximum load R in Ohms as a function of the supply voltage U₀ in Volts. The y-axis ranges from 0 to 500 Ω. The x-axis ranges from 10 to 35 V. The load R starts at 0 Ω for U₀ = 17.5 V and increases linearly to 500 Ω at U₀ = 28.5 V. From 28.5 V to 35 V, the load R remains constant at 500 Ω.</p>
Ex ia / IS	17.5 to 30 V ³⁾	
<ul style="list-style-type: none"> ▪ Ex d / XP ▪ Ex ic[ia] ▪ Ex tD / DIP 	16 to 30 V ³⁾	<p>The graph shows the maximum load R in Ohms as a function of the supply voltage U₀ in Volts. The y-axis ranges from 0 to 500 Ω. The x-axis ranges from 10 to 30 V. The load R starts at 0 Ω for U₀ = 16 V and increases linearly to 500 Ω at U₀ = 27 V. From 27 V to 30 V, the load R remains constant at 500 Ω.</p>

A0014079

A0034970

- 1) Feature 020 in the product structure: option A
- 2) Feature 010 in the product structure
- 3) If the Bluetooth module is used, the minimum supply voltage increases by 2 V.

2-wire; 4-20 mA HART, switch output ¹⁾

"Approval" ²⁾	Terminal voltage U at device	Maximum load R, depending on the supply voltage U ₀ of the power supply unit
<ul style="list-style-type: none"> ▪ Non-hazardous ▪ Ex nA ▪ Ex nA(ia) ▪ Ex ic ▪ Ex ic[ia] ▪ Ex d[ia] / XP ▪ Ex ta / DIP ▪ CSA GP 	16 to 35 V ³⁾	
<ul style="list-style-type: none"> ▪ Ex ia / IS ▪ Ex ia + Ex d[ia] / IS + XP 	16 to 30 V ³⁾	

A0034972

- 1) Feature 020 in the product structure: option B
- 2) Feature 010 in the product structure
- 3) If the Bluetooth module is used, the minimum supply voltage increases by 2 V.

2-wire; 4-20mA HART, 4-20mA ¹⁾

"Approval" ²⁾	Terminal voltage U at device	Maximum load R, depending on the supply voltage U ₀ of the power supply unit
all	Channel 1: 17 to 30 V ³⁾	
	Channel 2: 12 to 30 V	

A0034973

A0022583

- 1) Feature 020 in the product structure: option C
- 2) Feature 010 in the product structure
- 3) If the Bluetooth module is used, the minimum supply voltage increases by 2 V.

Integrated polarity reversal protection	Yes
Permitted residual ripple with f = 0 to 100 Hz	U _{SS} < 1 V
Permitted residual ripple with f = 100 to 10000 Hz	U _{SS} < 10 mV

4-wire, 4-20mA HART, active

"Power supply; output" ¹⁾	Terminal voltage U	Maximum load R _{max}
K: 4-wire 90-253VAC; 4-20mA HART	90 to 253 V _{AC} (50 to 60 Hz), overvoltage category II	500 Ω
L: 4-wire 10.4-48VDC; 4-20mA HART	10.4 to 48 V _{DC}	

1) Feature 020 in the product structure

PROFIBUS PA, FOUNDATION Fieldbus

"Power supply; output" ¹⁾	"Approval" ²⁾	Terminal voltage
E: 2-wire; FOUNDATION Fieldbus, switch output G: 2-wire; PROFIBUS PA, switch output	<ul style="list-style-type: none"> ▪ Non-hazardous ▪ Ex nA ▪ Ex nA[ia] ▪ Ex ic ▪ Ex ic[ia] ▪ Ex d[ia] / XP ▪ Ex ta / DIP ▪ CSA GP 	9 to 32 V ³⁾
	<ul style="list-style-type: none"> ▪ Ex ia / IS ▪ Ex ia + Ex d[ia] / IS + XP 	9 to 30 V ³⁾

1) Feature 020 in the product structure

2) Feature 010 in the product structure

3) Input voltages up to 35 V do not damage the device.

Polarity-dependent	Yes
FISCO/FNICO compliant according to IEC 60079-27	Yes

Power consumption	"Power supply; Output" ¹⁾	Power consumption
	A: 2-wire; 4-20mA HART	
B: 2-wire; 4-20mA HART, switch output		< 0.9 W
C: 2-wire; 4-20mA HART, 4-20mA		< 2 x 0.7 W
K: 4-wire 90-253VAC; 4-20mA HART		6 VA
L: 4-wire 10,4-48VDC; 4-20mA HART		1.3 W

1) Feature 020 of the product structure

Current consumption

HART

Nominal current	3.6 to 22 mA, the start-up current for multidrop mode can be parametrized (is set to 3.6 mA on delivery)
Breakdown signal (NAMUR NE43)	adjustable: 3.59 to 22.5 mA

PROFIBUS PA

Nominal current	18 mA
Failure current FDE (Fault Disconnection Electronic)	0 mA

FOUNDATION Fieldbus

Device basic current	15 mA
Failure current FDE (Fault Disconnection Electronic)	0 mA

FISCO

U _i	17.5 V
I _i	550 mA
P _i	5.5 W
C _i	5 nF
L _i	10 µH

Power supply failure

- Configuration is retained in the HistoROM (EEPROM).
- Error messages (incl. value of operated hours counter) are stored.

Potential equalization

No special measures for potential equalization are required.



If the device is designed for hazardous areas, observe the information in the documentation "Safety Instructions" (XA).

Terminals

- **Without integrated overvoltage protection**
Plug-in spring terminals for wire cross-sections 0.5 to 2.5 mm² (20 to 14 AWG)
- **With integrated overvoltage protection**
Screw terminals for wire cross-sections 0.2 to 2.5 mm² (24 to 14 AWG)

Cable entries

Connection of the power supply and signal cables

To be selected in feature 050 "Electrical connection":

- Coupling M20, material depends on approval:
 - For non-Ex, ATEX, IECEX, NEPSI Ex ia/ic:
Plastic M20x1.5 for cable Ø5 to 10 mm (0.2 to 0.39 in)
 - For Dust-Ex, FM IS, CSA IS, CSA GP, Ex ec:
 - For Ex db:
No cable gland available
- Thread
 - ½" NPT
 - G ½"
 - M20 × 1.5
- M12 plug / 7/8" plug
Only available for non-Ex, Ex ic, Ex ia

Connection of remote display FHX50

Feature 030 "Display, operation"	Cable entry for connection of FHX50
L: "Prepared for display FHX50 + M12 connection"	M12 socket
M: "Prepared for display FHX50 + custom connection"	M12 cable gland

Cable specification

- **Devices without integrated overvoltage protection**
Pluggable spring-force terminals for wire cross-sections 0.5 to 2.5 mm² (20 to 14 AWG)
- **Devices with integrated overvoltage protection**
Screw terminals for wire cross-sections 0.2 to 2.5 mm² (24 to 14 AWG)
- For ambient temperature T_U ≥ 60 °C (140 °F): use cable for temperature T_U + 20 K.

HART

- A normal device cable suffices if only the analog signal is used.
- A shielded cable is recommended if using the HART protocol. Observe grounding concept of the plant.
- For 4-wire devices: Standard device cable is sufficient for the power line.

PROFIBUS

Use a twisted, screened two-wire cable, preferably cable type A.

-  For further information on the cable specifications, see Operating Instructions BA00034S "PROFIBUS DP/PA: Guidelines for planning and commissioning", PNO Guideline 2.092 "PROFIBUS PA User and Installation Guideline" and IEC 61158-2 (MBP).

FOUNDATION Fieldbus

Endress+Hauser recommends using twisted, shielded two-wire cables.

-  For further information on the cable specifications, see Operating Instructions BA00013S "FOUNDATION Fieldbus Overview", FOUNDATION Fieldbus Guideline and IEC 61158-2 (MBP).

Overvoltage protection

If the device is intended to be used for level measurement of flammable liquids which requires overvoltage protection in accordance with DIN EN 60079-14, test standard 60060-1 (10 kA, pulse $\frac{8}{20}$ μ s): use the overvoltage protection module.

Integrated overvoltage protection module

An integrated overvoltage protection module is available for the HART 2-wire devices as well as for PROFIBUS PA and FOUNDATION Fieldbus.

Product structure: Feature 610 "Accessory mounted", option NA "Overvoltage protection".

Resistance per channel	Maximum $2 \times 0.5 \Omega$
DC sparkover voltage	400 to 700 V
Trip surge voltage	< 800 V
Capacity at 1 MHz	< 1.5 pF
Nominal discharge current (8/20 μs)	10 kA

External overvoltage protection module

The HAW562 or HAW569 for example from Endress+Hauser are suitable options for external overvoltage protection.

-  More information is provided in the following documents:
- HAW562: TI01012K
 - HAW569: TI01013K

Performance characteristics**Reference conditions**

- Temperature = +24 °C (+75 °F) ± 5 °C (± 9 °F)
- Pressure = 960 mbar abs. (14 psia) ± 100 mbar (± 1.45 psi)
- Humidity = 60 % ± 15 %
- Reflection factor ≥ 0.8 (water surface for coaxial probe, metal plate for rod and rope probe with min. 1 m (40 in) diameter)
- Flange for rod or rope probe ≥ 300 mm (12 in) diameter
- Distance to obstacles ≥ 1 m (40 in)
- For interface measurement:
 - Coaxial probe
 - ϵ_r of lower medium = 80 (water)
 - ϵ_r of upper medium = 2 (oil)

Reference accuracy Typical data under reference operating conditions: DIN EN IEC 61298-2 / DIN EN IEC 60770-1; percentage values in relation to the span.

Output:	digital	analog ¹⁾
Accuracy (sum of non-linearity, non-repeatability and hysteresis) ²⁾	Level measurement: Measuring distance ≤ 10 m (33 ft): ±2 mm (±0.08 in)	±0.02 %
	Interface measurement: <ul style="list-style-type: none"> ■ Measuring distance ≤ 500 mm (19.7 in): ±20 mm (±0.79 in) ■ Measuring distance > 500 mm (19.7 in): ±10 mm (±0.39 in) ■ If thickness of upper medium < 100 mm (3.94 in): ±40 mm (±1.57 in) 	
Non-repeatability ³⁾	≤ 1 mm (0.04 in)	

- 1) Add error of the analog value to the digital value.
- 2) If the reference conditions are not met, the offset/zero point resulting from the installation conditions can be up to ±16 mm (±0.63 in). This additional offset/zero point can be compensated for by entering a correction ("Level correction" parameter) during commissioning.
- 3) The non-repeatability is already considered in the accuracy.

In the area of the lower probe end, the following measurement error applies specifically for level measurement:

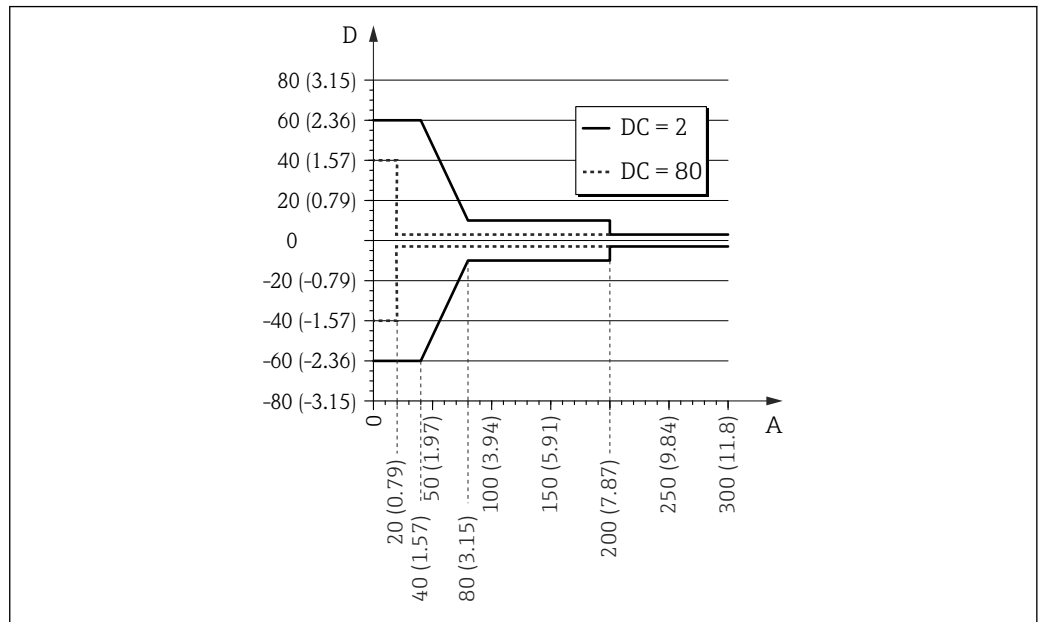

24 Measurement error at the probe end for rod and coaxial probes

- A Distance from the probe end [mm(in)]
 D Measurement error: Sum of non-linearity, non-repeatability and hysteresis
 DC Dielectric constant (ϵ_r)

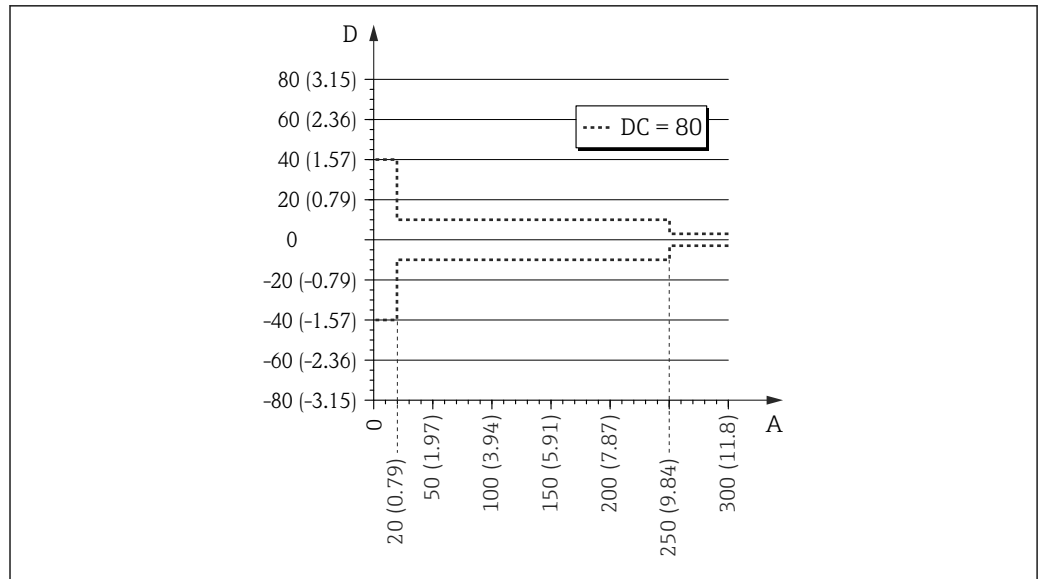

A0021482

25 Measurement error at the probe end for rope probes

- A Distance from the probe end [mm(in)]
- D Measurement error: Sum of non-linearity, non-repeatability and hysteresis
- DC Dielectric constant (ϵ_r)

i If the ϵ_r value is less than 7 in the case of rope probes, measurement is not possible in the area of the probe weight (0 to 250 mm (0 to 9.84) from the probe end), (lower blocking distance).

The following measurement error applies for level measurement in the area of the upper probe end:

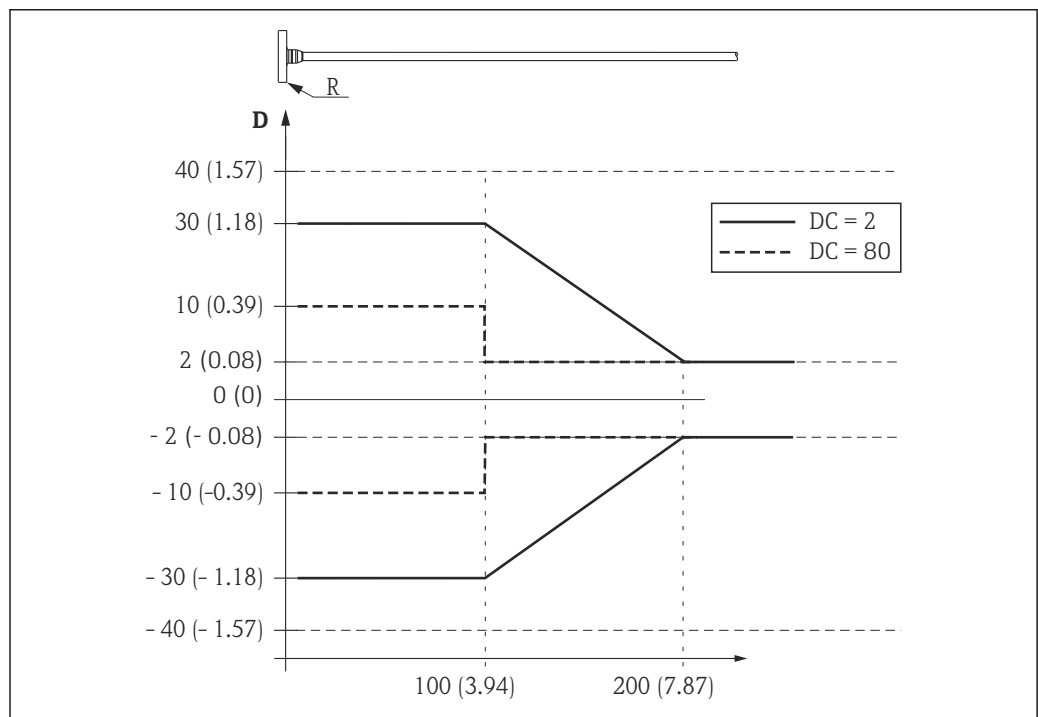

A0015091

26 Measurement error at the upper probe end; unit: mm (in)

- D Sum of non-linearity, non-repeatability and hysteresis
- R Reference point of the measurement
- DC Dielectric constant (ϵ_r)

Resolution

- Digital: 1 mm
- Analog: 1 μ A

Response time

The response time can be configured. The following step response times apply (in accordance with DIN EN IEC 61298-2/DIN EN IEC 60770-1) when damping is switched off.

In accordance with DIN EN IEC 61298-2/DIN EN IEC 60770-1, the step response time is the time following an abrupt change in the input signal up until the changed output signal has adopted 90% of the steady-state value for the first time.

Level measurement		
Probe length	Sampling rate	Response time
< 10 m (33 ft)	3.6 measurements per second	< 0.8 s

Interface measurement		
Probe length	Sampling rate	Response time
< 10 m (33 ft)	≥ 1.1 measurements per second	< 2.2 s

Influence of ambient temperature

The measurements are performed according to DIN EN IEC 61298-3 / DIN EN IEC 60770-1

- Digital (HART, PROFIBUS PA, FOUNDATION Fieldbus): average $T_K = 0.6$ mm/10 K
For devices with a remote sensor, there is an additional offset error of ± 0.3 mm/10K (± 0.01 in/10K) per 1 m (3.3 ft) of remote cable length.
- Analog (current output):
 - Zero point (4 mA): average $T_C = 0.02$ %/10 K
 - Span (20 mA): average $T_C = 0.05$ %/10 K

Installation

Mounting requirements

Suitable mounting position

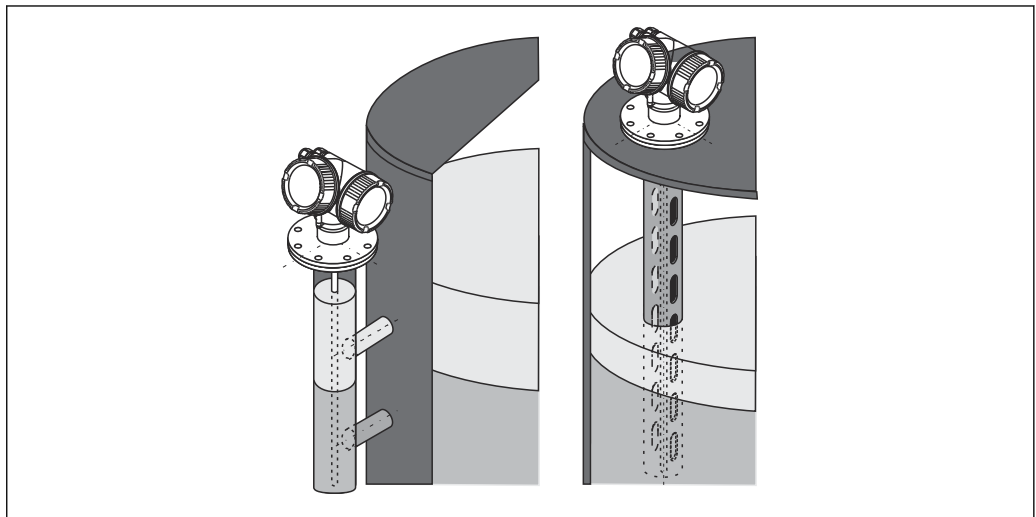

27 Mounting position of Levelflex FMP55

- Rod probes/rope probes: mount in the bypass/stilling well.
- Coaxial probes can be mounted at any distance from the wall.
- When mounting outdoors, a weather protection cover can be used to protect the device against extreme weather conditions.
- Minimum distance from the end of the probe to the bottom of the vessel: 10 mm (0.4 in)

Mounting under confined conditions

Mounting with remote probe

The device version with a remote probe is suitable for applications with restricted mounting space. In this case, the electronics housing is mounted at a separate position from the probe.

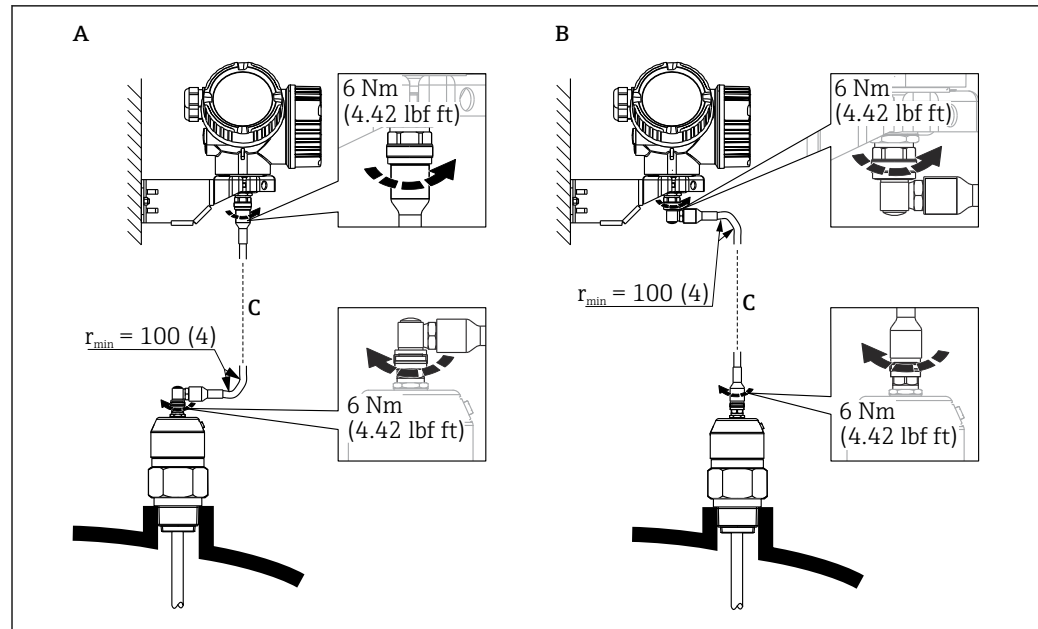

- A Angled plug at the probe
 B Angled plug at the electronics housing
 C Length of the remote cable as ordered

- Product structure, feature 600 "Probe design":
Version MB "Remote sensor, 3 m cable"
- The connecting cable is included in the delivery with these versions.
Minimum bending radius: 100 mm (4 inch)
- The mounting bracket for the electronics housing is included in the delivery with these versions.
Mounting options:
 - Wall mounting
 - Mounting on DN32 to DN50 (1¼ to 2 inch) post or pipe
- The connecting cable has one straight plug and one plug angled at 90°. Depending on the local conditions the angled plug can be connected at the probe or at the electronics housing.

i The probe, electronics and connection cable are mutually compatible and bear a common serial number. Only components with the same serial number may be connected to one another.

Notes on the mechanical load of the probe

Tensile loading capacity of rope probes

FMP55

Rope 4 mm (¼ in) PFA>316

Tensile loading capacity 2 kN

Lateral loading capacity (flexural strength) of rod probes

FMP55

Rod 16 mm (0.63 in) PFA>316L

Flexural strength 30 Nm

Lateral loading capacity (flexural strength) of coaxial probes

FMP55

Probe Ø 42.4 mm 316L
 Flexural strength:300 Nm

Mounting cladded flanges



Note the following for cladded flanges:

- Use the same number of flange screws as the number of flange bores provided.
- Tighten the screws with the necessary torque (see Table).
- Retighten after 24 hours or after the first temperature cycle.
- Depending on the process pressure and temperature, check and retighten the screws, where necessary, at regular intervals.

The PTFE flange cladding normally acts simultaneously as a seal between the nozzle and the device flange.

Flange size	Number of screws	Tightening torque
EN		
DN40/PN40	4	35 to 55 Nm
DN50/PN16	4	45 to 65 Nm
DN50/PN40	4	45 to 65 Nm
DN80/PN16	8	40 to 55 Nm
DN80/PN40	8	40 to 55 Nm
DN100/PN16	8	40 to 60 Nm
DN100/PN40	8	55 to 80 Nm
DN150/PN16	8	75 to 115 Nm
DN150/PN40	8	95 to 145 Nm
ASME		
1½"/150lbs	4	20 to 30 Nm
1½"/300lbs	4	30 to 40 Nm
2"/150lbs	4	40 to 55 Nm
2"/300lbs	8	20 to 30 Nm
3"/150lbs	4	65 to 95 Nm
3"/300lbs	8	40 to 55 Nm
4"/150lbs	8	45 to 70 Nm
4"/300lbs	8	55 to 80 Nm
6"/150lbs	8	85 to 125 Nm
6"/300lbs	12	60 to 90 Nm
JIS		
10K 40A	4	30 to 45 Nm
10K 50A	4	40 to 60 Nm
10K 80A	8	25 to 35 Nm
10K 100A	8	35 to 55 Nm
10K 100A	8	75 to 115 Nm

Securing the probe

Securing coaxial probes

For WHG approval: a support is required for probe lengths ≥ 3 m (10 ft).

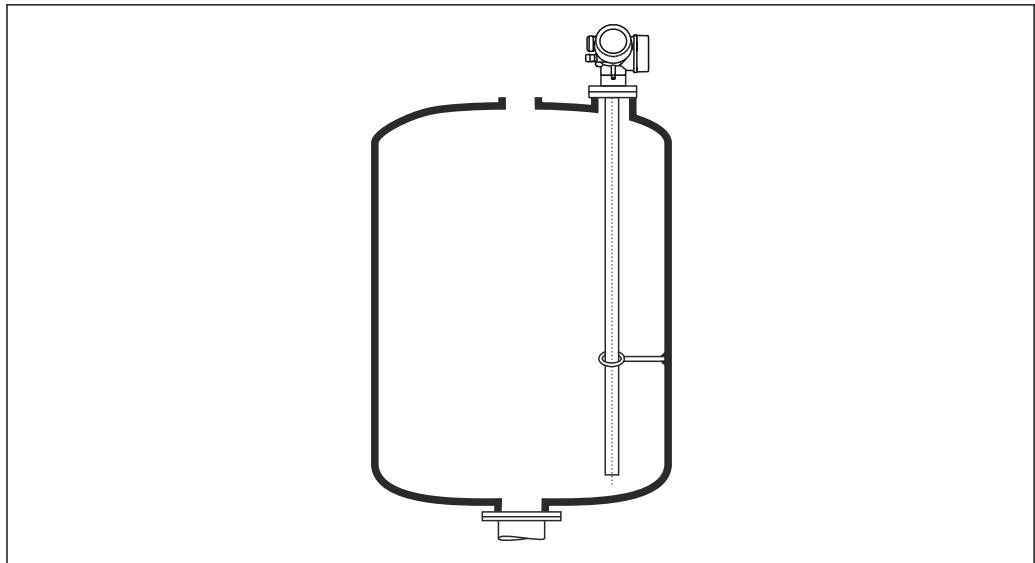

A0012608

Coaxial probes can be secured (fixed) at any point in the ground tube.

Special installation situations

Bypasses and stilling wells

- i** The use of centering disks/stars/weights (available as accessories) is recommended in bypass and stilling well applications.
- i** Since the measuring signal permeates a large number of plastics, incorrect measurements can result when the device is installed in bypasses or stilling wells made of plastic. For this reason use a bypass or stilling well made of metal.

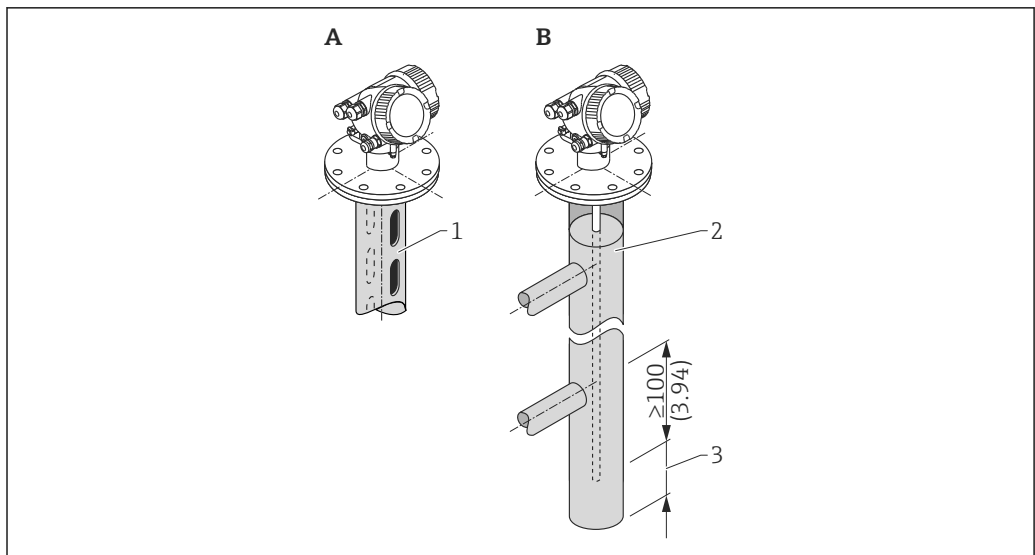

A0014129

- 1 *Mounting in stilling well*
- 2 *Mounting in bypass*
- 3 *Minimum distance between probe end and lower edge of bypass 10 mm (0.4 in)*

- Pipe diameter: > 40 mm (1.6 in) (for rod probes).
- A rod probe can be installed in pipes with a diameter of up to 150 mm (6 in). The use of a coaxial probe is recommended for larger pipe diameters.
- Side outlets, holes, slots and welds - with a maximum inward projection of 5 mm (0.2 in) - do not affect the measurement.
- There should not be any changes in the diameter of the pipe.

- The probe must be 100 mm (4 in) longer than the lower outlet.
- The probes must not touch the pipe wall within the measuring range. Support or brace the probe if necessary. All rope probes are prepared for bracing in vessels (probe weight with anchor hole).
- The probes must not touch the pipe wall within the measuring range. If necessary, use a PFA centering star.
- Coaxial probes can be used within any restrictions provided that the pipe diameter permits their installation.

i For bypasses with condensate formation (water) and a medium with a low relative permittivity (e.g. hydrocarbons):

Over time, the bypass fills with condensate up to the lower outlet. When levels are low, the level echo is masked by the echo of the condensate as a result. In this range, the level of the condensate is output and the correct value is only output when levels are higher. For this reason, ensure that the lower outlet is 100 mm (4 in) below the lowest level to be measured and fit a metal centering disk at the level of the lower edge of the lower outlet.

i In thermally insulated vessels, the bypass should also be insulated in order to prevent condensate formation.

Assignment of centering disk/centering star/centering weight to the pipe diameter

Underground tanks

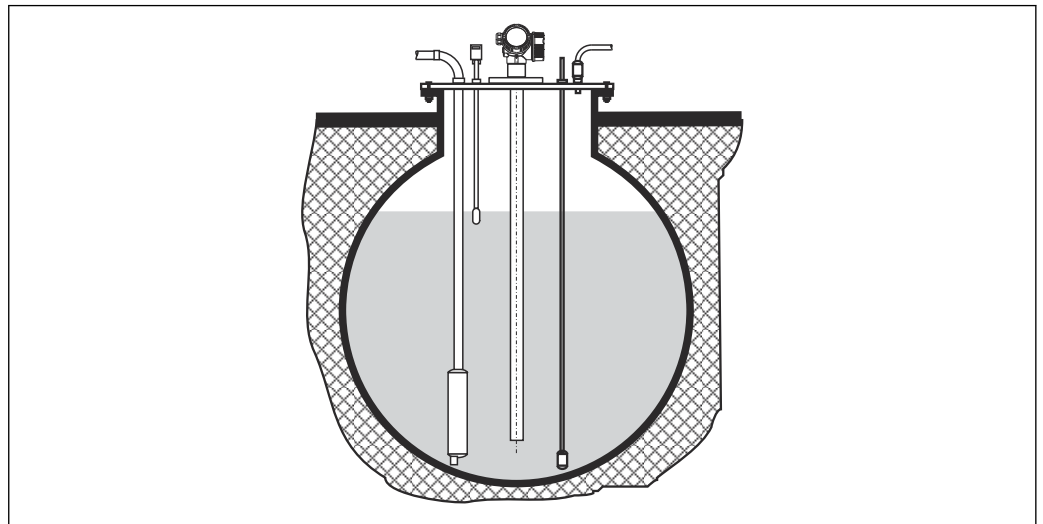

A0014142

In the case of nozzles with large diameters, use a coaxial probe to avoid reflections at the nozzle wall.

Non-metal vessels

Use a coaxial probe if mounting in non-metal vessels.

Vessel with thermal insulation

i If process temperatures are high, the device must be included in normal vessel insulation (1) in order to prevent the electronics heating up as a result of thermal radiation or convection. The insulation may not go beyond the points labeled "MAX" in the drawings.

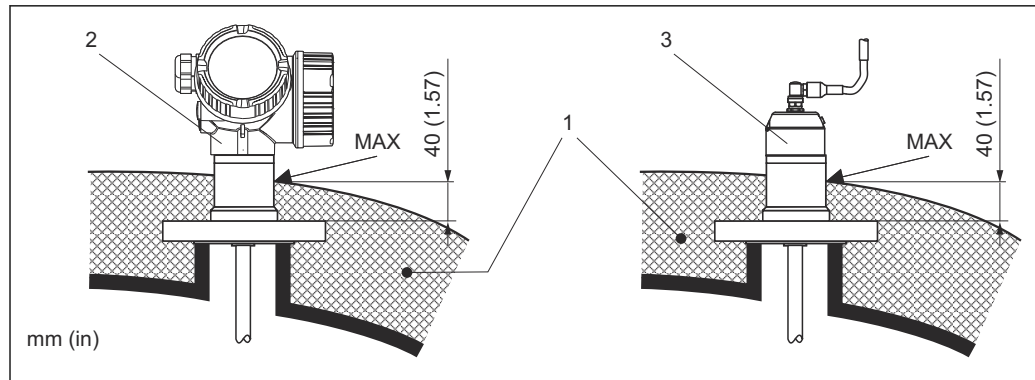

A0014654

28 Process connection with flange

- 1 Vessel insulation
- 2 Compact device
- 3 Sensor, remote

Environment

Ambient temperature

Device	-40 to +80 °C (-40 to +176 °F)
Local display	-20 to +70 °C (-4 to +158 °F), the readability of the local display may be impaired at temperatures outside the temperature range.
Connecting cable (for "Sensor, remote" probe design)	-50 to +100 °C (-58 to +212 °F)
Remote display FHX50	-40 to 80 °C (-40 to 176 °F)
Remote display FHX50 (option)	-50 to 80 °C (-58 to 176 °F) ¹⁾

- 1) This range applies if the option JN "Transmitter ambient temperature -50 °C (-58 °F)" has been selected in order code 580 "Test, certificate". If the temperature is permanently below -40 °C (-40 °F), higher failure rates can be expected.

If operating outdoors in strong sunlight:

- Mount the device in the shade.
- Avoid direct sunlight, particularly in warm climatic regions.
- Use a weather protection cover (accessory).

Ambient temperature limits

The following diagrams only consider functional aspects. Additional restrictions may apply for certified device versions. See the separate Safety Instructions for more information.

In the event of temperature (T_p) at the process connection, the permitted ambient temperature (T_a) is reduced as indicated in the following diagram (temperature derating):

Temperature derating for FMP55

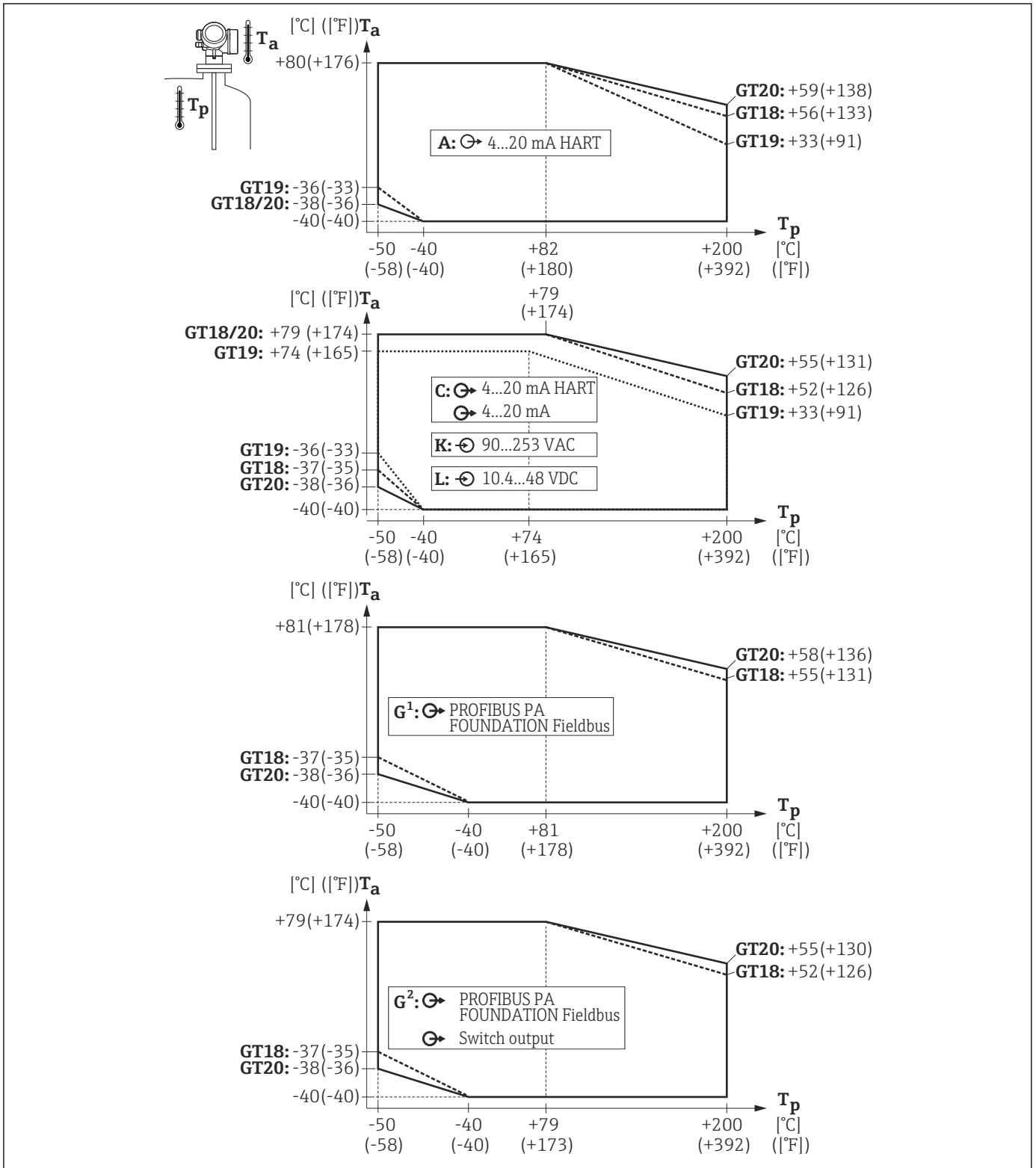

A0013630

GT18 = Stainless steel housing
 GT19 = Plastic housing
 GT20 = Aluminum housing

A = 1 current output
 C = 2 current outputs
 G¹, G² = PROFIBUS PA ¹⁾
 K, L = 4-wire

T_a = Ambient temperature
 T_p = Temperature at the process connection

1) In the case of PROFIBUS PA and FOUNDATION Fieldbus, the temperature derating depends on whether the switch output (terminals 3 and 4) is used (G²) or not (G¹).

Storage temperature	<ul style="list-style-type: none"> ■ Permitted storage temperature: -40 to +80 °C (-40 to +176 °F) ■ Use original packaging.
Climate class	DIN EN 60068-2-38 (test Z/AD)
Operating height	<ul style="list-style-type: none"> ■ Generally up to 2 000 m (6 600 ft) above sea level. ■ Over 2 000 m (6 600 ft) under the following conditions: <ul style="list-style-type: none"> ■ Order code 020 "Power supply; output"= A, B, C, E or G (2-wire versions) ■ Supply voltage U < 35 V ■ Power supply, overvoltage category 1
Degree of protection	<p>Tested according to:</p> <ul style="list-style-type: none"> ■ With housing closed: IP68, NEMA6P (24 h at 1.83 m (6 ft) under water) (also applies for the "Remote sensor" version) <ul style="list-style-type: none"> ■ For housing: GT19 dual compartment, PBT plastic in combination with display, operation: SD02 or SD03: IP68 (24 h at 1 m (3.28 ft) under water) ■ IP66, NEMA4X ■ With housing open: IP20, NEMA1 ■ Display module: IP22, NEMA2 ■ For M12 plug: IP68 NEMA6P, only if the cable is plugged in and also specified according to IP68 NEMA6P
Vibration resistance	DIN EN 60068-2-64 / IEC 60068-2-64: 20 to 2 000 Hz, 1 (m/s ²)/Hz
Cleaning the probe	<p>Dirt or buildup may form on the probe depending on the application. A thin, even layer has little impact on the measurement. Thick layers can dampen the signal and reduce the measuring range. Very uneven deposit formation or caking (e.g. due to crystallization) can result in incorrect measurements. In such cases, use a non-contact measuring principle, or regularly inspect the probe for contamination.</p> <p>Cleaning with sodium hydroxide solution (e.g. in CIP procedures): if the coupling is wetted, larger measurement errors can occur than under reference operating conditions. Wetting can cause temporary incorrect measurements.</p>
Electromagnetic compatibility (EMC)	<p>Electromagnetic compatibility in accordance with all the relevant requirements outlined in the EN 61326 series and NAMUR Recommendation EMC (NE 21). For details, refer to the Declaration of Conformity.</p> <p> Download from www.endress.com.</p> <p>Use a shielded cable for signal transmission.</p> <p>Maximum measurement error during EMC testing: < 0.5 % of the span.</p> <p>When the probes are installed in metal and concrete vessels and when a coaxial probe is used:</p> <ul style="list-style-type: none"> ■ Interference emission according to EN 61326-x series, Class B equipment. ■ Interference immunity according to EN 61326-x series, requirements for industry and NAMUR Recommendation NE 21 (EMC) <p>When probes are installed without a shielding/metal wall, e.g. installation in plastic or wooden silos, or when the "Remote sensor" device version is used, strong electromagnetic fields can affect the measured value.</p> <ul style="list-style-type: none"> ■ Interference emission according to EN 61326-x series, Class A equipment. ■ Interference immunity: the effect of strong electromagnetic fields can influence the measured value.

Process

Process temperature range The maximum temperature permitted at the process connection is determined by the O-ring version ordered:

Device	O-ring material	Process temperature
FMP55	—	-50 to +200 °C (-58 to +392 °F); fully coated

 High process temperatures (> 150 °C (302 °F)) may favor the diffusion of the medium through the probe coating, which may reduce the operating time.

Process pressure range

Device	Process pressure
FMP55	-1 to 40 bar (-14.5 to 580 psi)

 The range indicated can be reduced by the choice of process connection. The maximum working pressure (MWP) indicated on the nameplate refers to a reference temperature of 20 °C, and of 100 °F for ASME flanges. Observe pressure-temperature dependency.

Please refer to the following standards for the pressure values permitted at higher temperatures:

- EN 1092-1: 2007 Tab. G.4.1-x
With regard to their stability-temperature property, the materials 1.4435 and 1.4404 are grouped together under 13E0 in EN 1092-1: 2007 Tab. G.3.1-1. The chemical composition of the two materials can be identical.
- ASME B 16.5a - 2013 Tab. 2-2.2 F316
- ASME B 16.5a - 2013 Tab. 2.3.8 N10276
- JIS B 2220

Relative permittivity and conductivity

- ϵ_r (upper medium) ≤ 10
- ϵ_r (lower medium) - ϵ_r (upper medium) ≥ 10
- Interface thickness ≥ 60 mm (2.4 in)
- Conductivity (upper medium): ≤ 1 $\mu\text{S}/\text{cm}$
- Conductivity (lower medium): ≥ 100 $\mu\text{S}/\text{cm}$

Extension of the rope probe

Extension of the rope probes due to temperature

Elongation due to temperature increase from 30 °C (86 °F) to 150 °C (302 °F): 2 mm/m (0.08 in/ft) rope length

Mechanical construction

Dimensions

Dimensions of the electronics housing

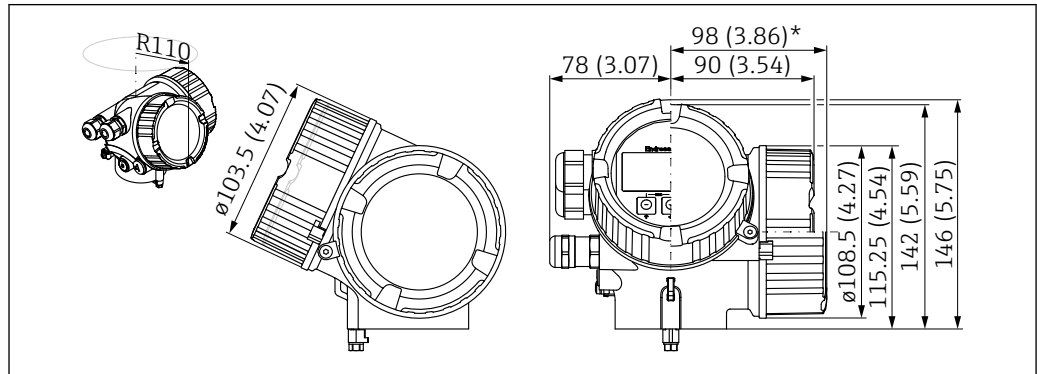

A0011666

29 Housing GT18 (316L). Unit of measurement mm (in)

*For devices with integrated overvoltage protection.

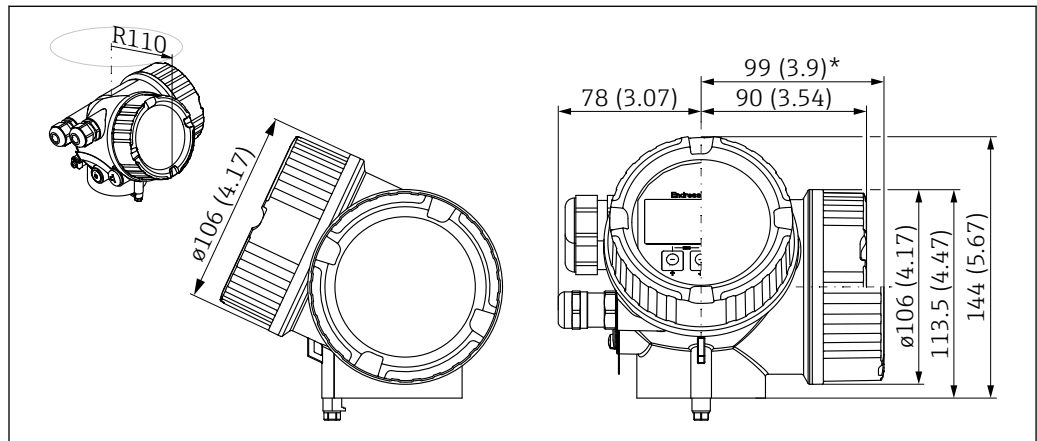

A0011346

30 GT19 housing (plastic PBT). Unit of measurement mm (in)

*For devices with integrated overvoltage protection.

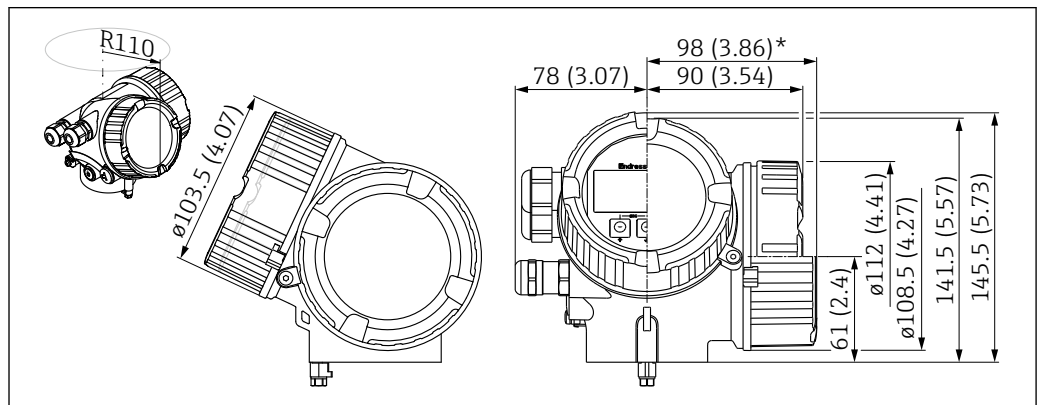

A0020751

31 Housing GT20 (aluminum coated). Unit of measurement mm (in)

*For devices with integrated overvoltage protection.

Mounting bracket dimensions

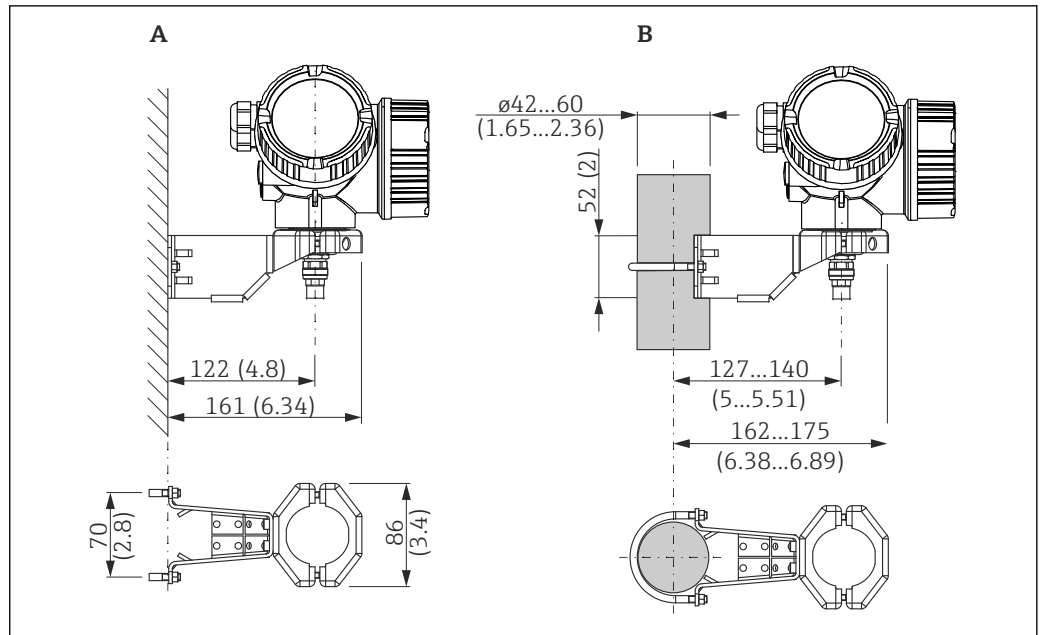

32 Mounting bracket for electronics housing. Unit of measurement mm (in)

- A Wall mounting
- B Post mounting

i With "remote sensor" device versions (see feature 060 in the product structure), the mounting bracket is included in the scope of delivery. However, it can also be ordered separately as an accessory (order number: 71102216).

Dimensions of connection piece for remote probe

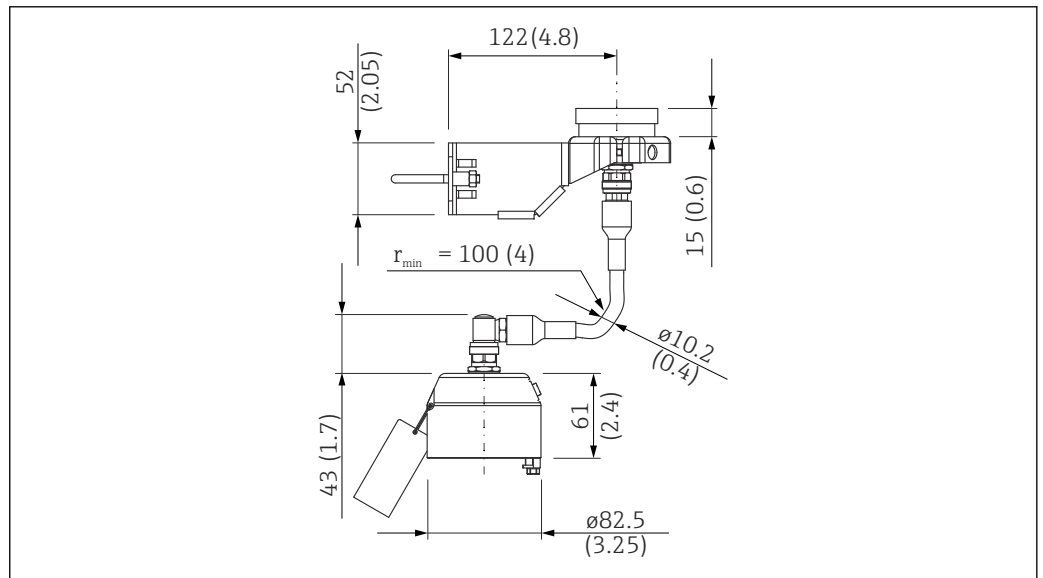

33 Connection piece for remote probe; length of connecting cable: as per order. Unit of measurement mm (in)

FMP55: Dimensions of process connection/probe

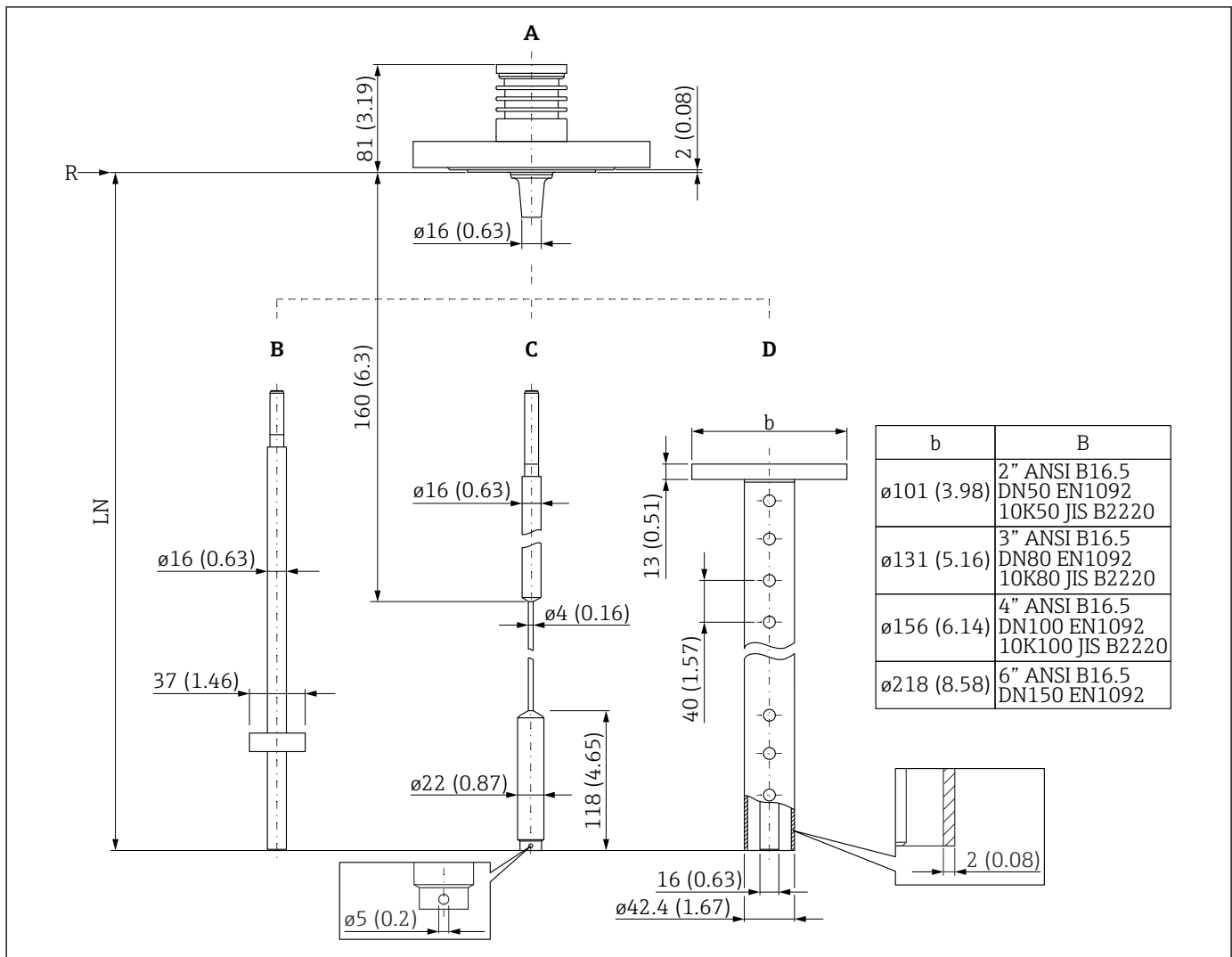

A0012779

34 FMP55: Process connection / probe. Unit of measurement mm (in)

- A Device flange ANSI B16.5, EN1092-1, JIS B2220 (feature 100)
- B Rod probe 16 mm (0.63 in), PFA > 316L (feature 060)
- C Rope probe 4 mm or 1/16", PFA > 316 (feature 060)
- D Coaxial probe (feature 060); vent openings ϕ approx. 10 mm (0.4 in)
- LN Probe length (for FMP55 with coaxial pipe, see following chapter)
- R Reference point of measurement

Determining the probe length LN in FMP55 with coaxial pipe

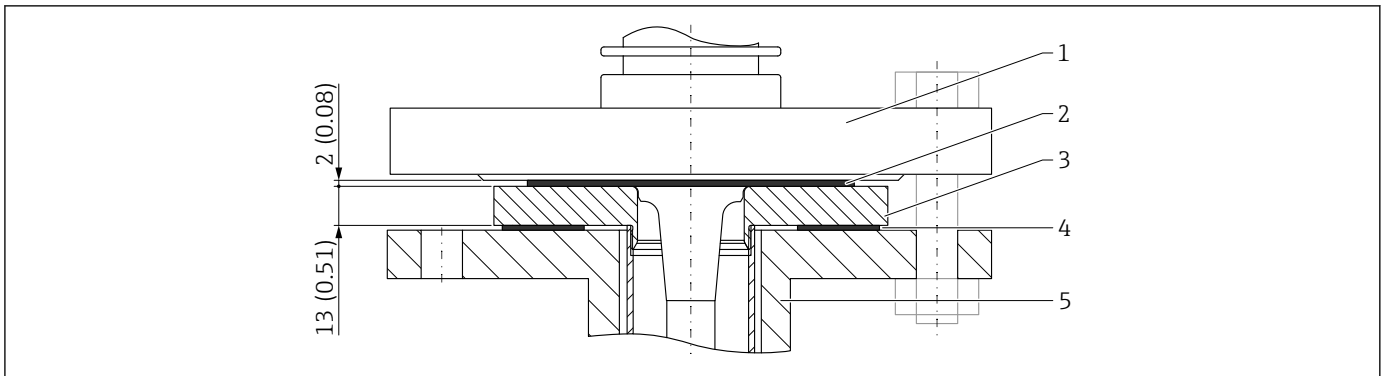

A0047956

Unit of measurement mm (in)

- 1 Device flange FMP55
- 2 PTFE coating
- 3 Adapter disk of the coaxial pipe
- 4 Customer-supplied process seal
- 5 Customer-supplied flange



Probe length "LN" for coaxial probes: The reference point "R" of the measurement shifts upwards by 15 mm (0.59 in) since the adapter disk of the coaxial pipe is located between the tank nozzle and the device flange. The dimension of 15 mm (0.59 in) results from the thickness of the adapter disk of 13 mm (0.51 in) and the thickness of the PTFE cladding of the device flange.

Probe length tolerances**Rod and coaxial probes**

Permitted tolerance depending on the probe length:

- < 1 m (3.3 ft) = -5 mm (-0.2 in)
- 1 to 3 m (3.3 to 9.8 ft) = -10 mm (-0.39 in)
- 3 to 6 m (9.8 to 20 ft) = -20 mm (-0.79 in)
- > 6 m (20 ft) = -30 mm (-1.18 in)

Rope probes

Permitted tolerance depending on the probe length:

- < 1 m (3.3 ft) = -10 mm (-0.39 in)
- 1 to 3 m (3.3 to 9.8 ft) = -20 mm (-0.79 in)
- 3 to 6 m (9.8 to 20 ft) = -30 mm (-1.18 in)
- > 6 m (20 ft) = -40 mm (-1.57 in)

Weight

The weights of the individual components must be added together for the total weight.

Housing

Weight including electronics and display.

GT18 housing (stainless steel, corrosion-resistant)

4.5 kg (9.92 lb)

GT19 housing (plastic)

1.2 kg (2.65 lb)

GT20 housing (die-cast aluminum, powder-coated)

Approx. 1.9 kg (4.19 lb)

Antenna and process connection adapter**FMP55**

The weights of the individual components must be added together for the total weight.

- Sensor
Approx. 1.20 kg/m (2.65 lb/in) + flange weight
- Rope probe 4 mm or 1/6"
Approx. 0.50 kg/m (1.10 lb/in) probe length
- Rod probe 16 mm (0.63 in)
Approx. 1.10 kg/m (2.43 lb/in) probe length
- Coaxial probe
Approx. 3.50 kg/m (7.72 lb/in) probe length

Materials

Materials not in contact with process

GT18 housing (stainless steel, corrosion-resistant)

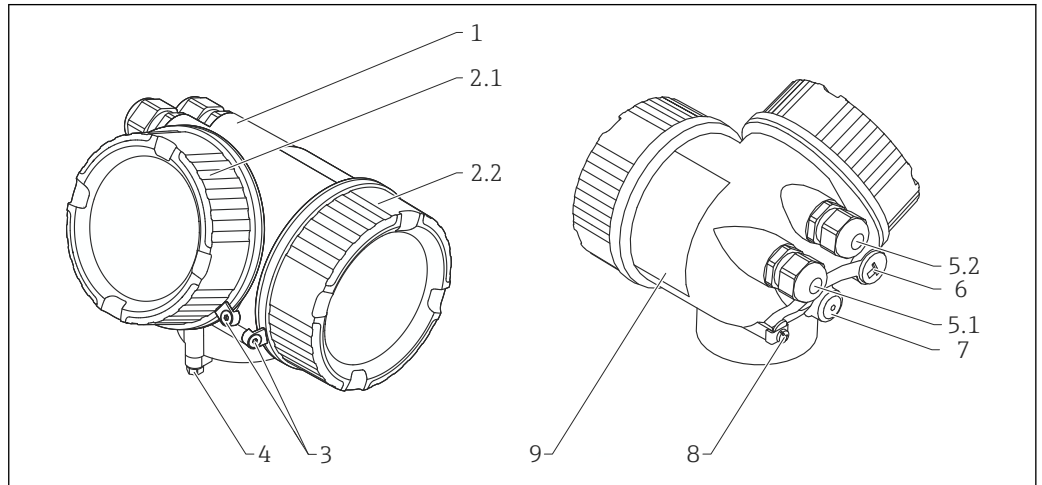

A0036037

35 Material; GT18 housing

- 1 Housing; CF3M (similar to 316L/ 1.4404)
- 2.1 Electronics compartment cover; CF3M (similar to 316L/ 1.4404), seals; NBR, window; glass, thread coating; graphite-based lubricant varnish
- 2.2 Connection compartment cover; CF3M (similar to 316L/ 1.4404), seal; NBR, thread coating; graphite-based lubricant varnish
- 3 Cover lock; 316L (1.4404), A4
- 4 Lock at the housing neck; 316L (1.4404), A4-70
- 5.1 Dummy plug, gland, adapter or plug (depending on the device version); 316L (1.4404), NBR, Viton, EPDM, PE, PBT-GF, nickel-plated brass (CuZn)
- 5.2 Dummy plug, gland, adapter or plug (depending on the device version); 316L (1.4404), NBR
- 6 Dummy plug or M12 socket (depending on the device version); 316L (1.4404)
- 7 Pressure relief plug; 316L (1.4404)
- 8 Ground terminal; 316L (1.4404), A4 (1.4571)
- 9 Nameplate; 316L (1.4404), A4 (1.4571)

GT19 housing (plastic)

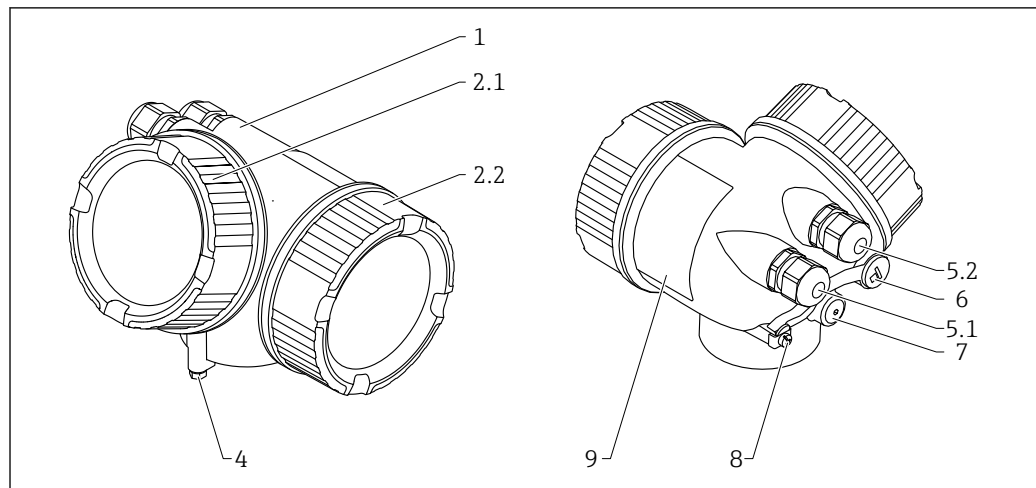

A0013788

36 Material; GT19 housing

- 1 Housing; PBT
- 2.1 Electronics compartment cover; PBT-PC, seals; EPDM, window; PC, thread coating; graphite-based lubricant varnish
- 2.2 Connection compartment cover; PBT, seal; EPDM, thread coating; graphite-based lubricant varnish
- 4 Lock at the housing neck; 316L (1.4404), A4-70
- 5.1 Dummy plug, gland, adapter or plug (depending on the device version); 316L (1.4404), EPDM, PE, PBT-GF, nickel-plated brass (CuZn), PA
- 5.2 Dummy plug, gland, adapter or plug (depending on the device version); 316L (1.4404), EPDM, PE, PBT-GF, galvanized steel, nickel-plated brass (CuZn), PA
- 6 Dummy plug; nickel-plated brass (CuZn), M12 socket; GD-Zn nickel-plated
- 7 Pressure relief plug; nickel-plated brass (CuZn)
- 8 Ground terminal; 316L (1.4404), A4 (1.4571)
- 9 Adhesive nameplate; plastic

GT20 housing (die-cast aluminum, powder-coated)

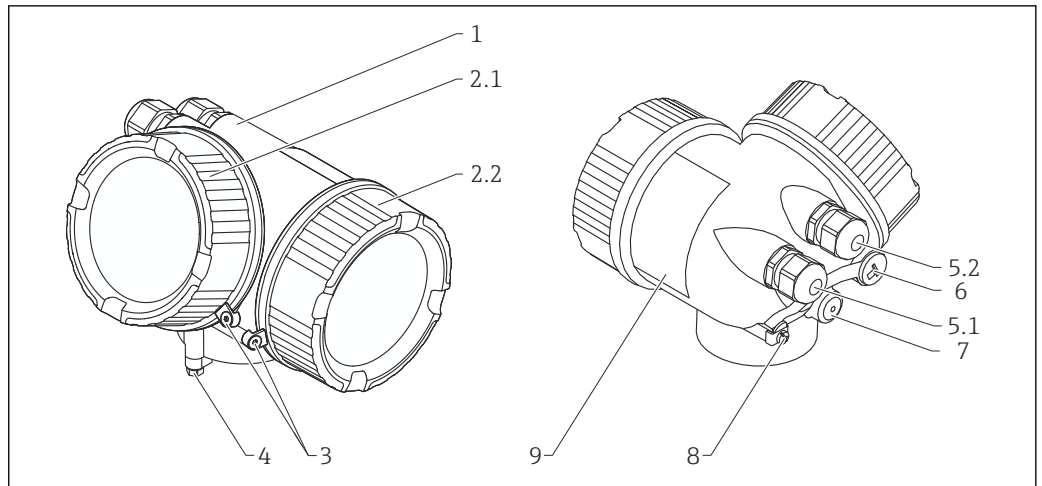

A0036037

37 Material; GT20 housing

- 1 Housing RAL 5012 (blue); AlSi10Mg (<0.1% Cu), coating; polyester
- 2.1 Electronics compartment cover RAL 7035 (gray); AlSi10Mg (<0.1% Cu), seals; NBR, window; glass, thread coating; graphite-based lubricant varnish
- 2.2 Connection compartment cover RAL 7035 (gray); AlSi10Mg (<0.1% Cu), seals; NBR, thread coating; graphite-based lubricant varnish
- 3 Cover lock; 316L (1.4404), A4
- 4 Lock at the housing neck; 316L (1.4404), A4-70
- 5.1 Dummy plug, gland, adapter or plug (depending on the device version); 316L (1.4404), EPDM, PE, PBT-GF, nickel-plated brass (CuZn), PA
- 5.2 Dummy plug, gland, adapter or plug (depending on the device version); 316L (1.4404), EPDM, PE, PBT-GF, galvanized steel, nickel-plated brass (CuZn), PA
- 6 Dummy plug; nickel-plated brass (CuZn), M12 socket; GD-Zn nickel-plated
- 7 Pressure relief plug; nickel-plated brass (CuZn)
- 8 Ground terminal; 316L (1.4404), A4 (1.4571)
- 9 Adhesive nameplate; plastic

Materials in contact with the medium

Process connection

i Endress+Hauser supplies DIN/EN flanges in stainless steel as per AISI 316L (DIN/ EN material number 1.4404 or 14435). With regard to their stability-temperature property, the materials 1.4404 and 1.4435 are grouped together under 13E0 in EN 1092-1: 2007 Tab. G.3.1-1. The chemical composition of the two materials can be identical.

Levelflex FMP55		
Flange EN/ASME/JIS	No.	Material
	1	316L (1.4404)
	2	ASME: 316/316L EN: 316L (1.4404) JIS: 316L (1.4435)
	4	Coating 2 mm (0.8 in): PTFE (Dyneon TFM1600)

A0014650

Adapter and cable for remote sensor

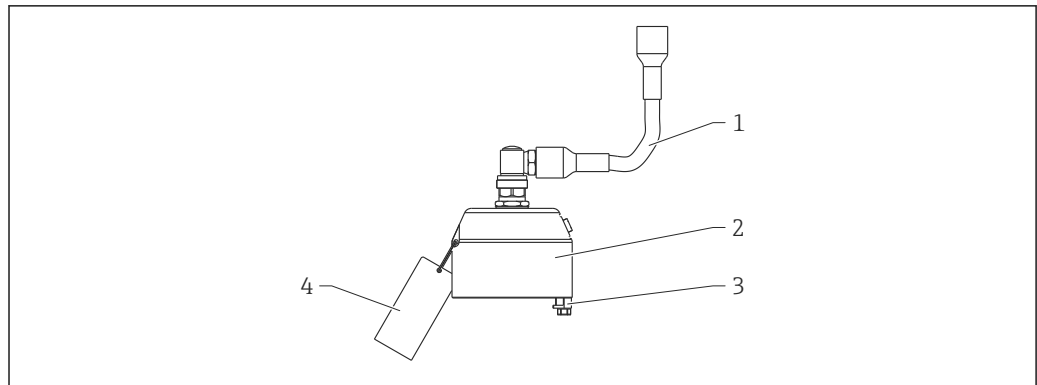

A0021722

38 Materials: Adapter and cable for "Remote sensor" version

- 1 Cable, FRNC
- 2 Sensor adapter, 304 (1.4301)
- 3 Terminal, 316 L (1.4404); screw, A4-70
- 4 Strap, 316 (1.4401); crimp sleeve, aluminum; nameplate, 304 (1.4301)

Probe

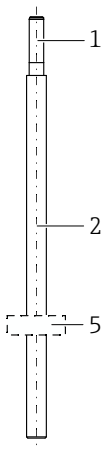
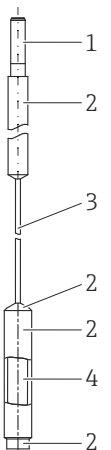
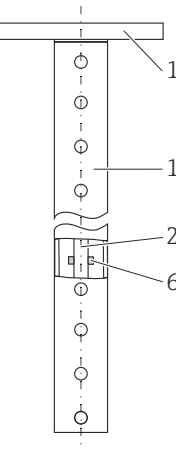
Levelflex FMP55				
Feature 060 "Probe"			No.	Material
<ul style="list-style-type: none"> ▪ CA: rod 16mm ▪ CB: rod 0.63in  <p>A0013870</p>	<ul style="list-style-type: none"> ▪ NA: rope 4mm ▪ ND: rope 1/6"  <p>A0036599</p>	<ul style="list-style-type: none"> ▪ UA: ...mm, coax ▪ UB: ...inch, coax  <p>A0036703</p>	1	316L (1.4404)
			2	Coating 0.02 mm (0.08 in): PFA (Daikin PFA AP230)
			3	Rope: 316 (1.4401) Coating 0.75 mm (0.03 in): PFA (Daikin PFA AP230)
			4	Core: 316L (1.4435)
			5	Centering star, PFA ¹⁾
			6	Centering star, PFA

1) Feature 610 "Accessory mounted" = OE "Rod centering star d=37mm, PFA, interface measurement"

Operability

Operation concept

Operator-oriented menu structure for user-specific tasks

- Commissioning
- Operation
- Diagnostics
- Expert level

Operating languages

- English
- Deutsch
- Français
- Español

- Italiano
- Nederlands
- Portuguesa
- Polski
- русский язык (Russian)
- Svenska
- Türkçe
- 中文 (Chinese)
- 日本語 (Japanese)
- 한국어 (Korean)
- Bahasa Indonesia
- tiếng Việt (Vietnamese)
- čeština (Czech)



Feature 500 in the product structure determines which of these languages is preset on delivery.

Quick and safe commissioning

- Interactive wizard with graphical user interface for guided commissioning in FieldCare/DeviceCare
- Menu guidance with brief descriptions of the individual parameter functions
- Standardized operation at the device and in the operating tools

Integrated data memory (HistoROM)

- Adoption of data configuration when electronics modules are replaced
- Up to 100 event messages recorded in the device
- Data logging with up to 1000 logged values
- A reference signal curve is saved during commissioning for later use as a reference during operation.

Efficient diagnostic behavior increases measurement availability

- Remedial action is integrated in plain text.
- Diverse simulation options and line recorder functions

Integrated Bluetooth module (option for HART devices)

- Quick and easy setup with the SmartBlue app
- No additional tools or adapters needed
- Signal curve via SmartBlue (app)
- Encrypted single point-to-point data transmission (tested by Fraunhofer Institute) and password-protected communication via *Bluetooth*® wireless technology

Access to operating menu via local display

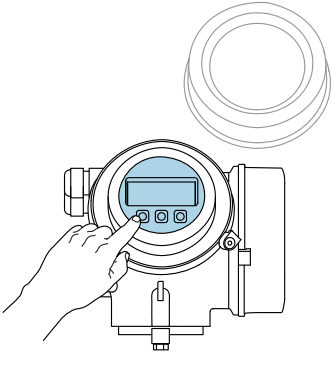
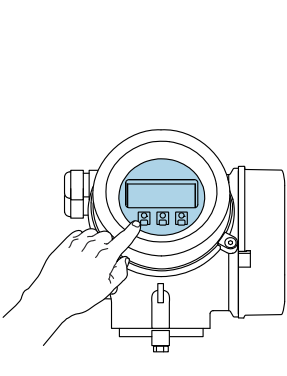
Operation with	Pushbuttons	Touch control
Order code for "Display; operation"	Option C "SD02"	Option E "SD03"
	 <small>A0036312</small>	 <small>A0036313</small>
Display elements	4-line display	4-line display White background lighting; switches to red in event of device errors
	Format for displaying measured variables and status variables can be individually configured	
	Permitted ambient temperature for the display: -20 to +70 °C (-4 to +158 °F) The readability of the display may be impaired at temperatures outside the temperature range.	
Operating elements	Onsite operation with 3 pushbuttons (⊕, ⊖, ⊞)	External operation via touch control; 3 optical keys: ⊕, ⊖, ⊞
	Operating elements also accessible in various hazardous areas	
Additional functionality	Data backup function The device configuration can be saved in the display module.	
	Data comparison function The device configuration saved in the display module can be compared to the current device configuration.	
	Data transfer function The transmitter configuration can be transmitted to another device using the display module.	

Operation with remote display and operating module FHX50

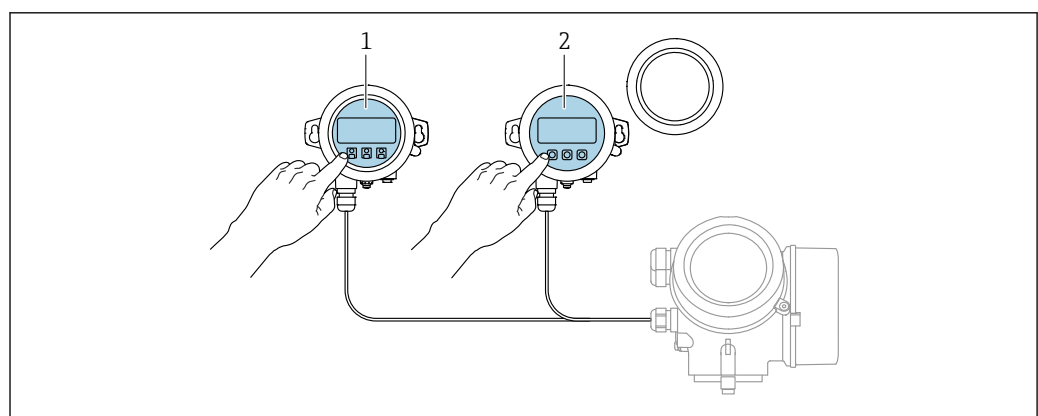

 39 FHX50 operating options

- 1 Display and operating module SD03, optical keys; can be operated through the glass of the cover
- 2 Display and operating module SD02, push buttons; cover must be removed

Access to the operating menu via the operating tool

Via HART protocol

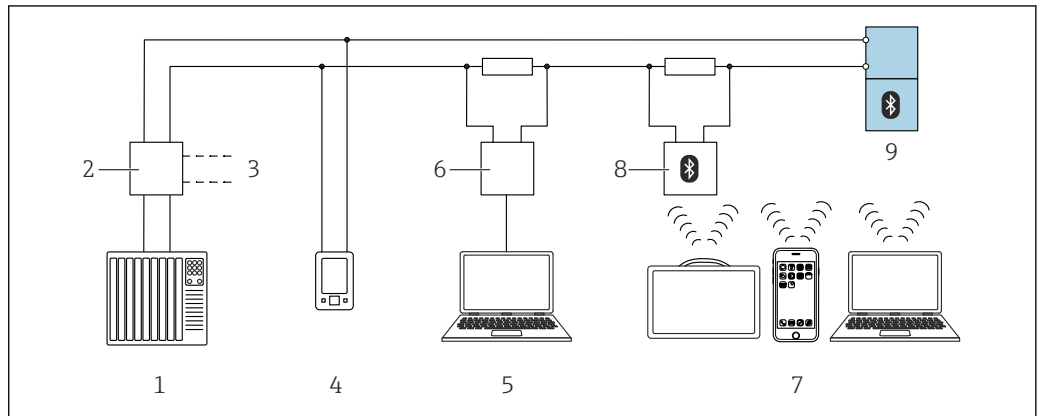

A0044334

40 Options for remote operation via HART protocol

- 1 PLC (programmable logic controller)
- 2 Transmitter power supply unit, e.g. RN42 (with communication resistor)
- 3 Connection for Commubox FXA195 and AMS Trex Device Communicator
- 4 AMS Trex Device Communicator
- 5 Computer with operating tool e.g. DeviceCare, FieldCare, AMS Device View, SIMATIC PDM)
- 6 Commubox FXA195 (USB)
- 7 Field Xpert SMT70/SMT77, smartphone or computer with operating tool (e.g. DeviceCare, SmartBlue app)
- 8 Bluetooth modem with connecting cable (e.g. VIATOR)
- 9 Transmitter

Via PROFIBUS PA protocol

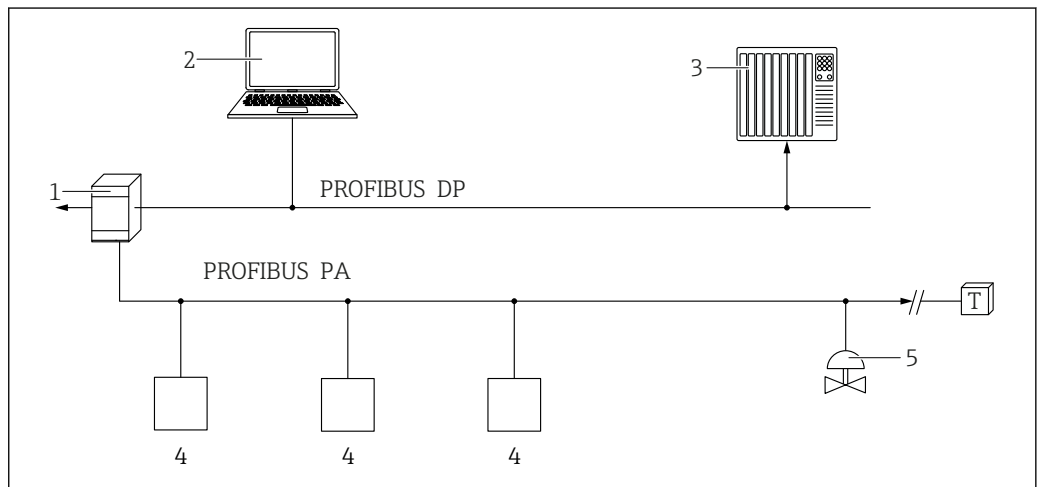

A0050944

- 1 Segment coupler
- 2 Computer with PROFibus and operating tool (e.g. DeviceCare/FieldCare)
- 3 PLC (programmable logic controller)
- 4 Transmitter
- 5 Additional functions (valves etc.)

Via FOUNDATION Fieldbus

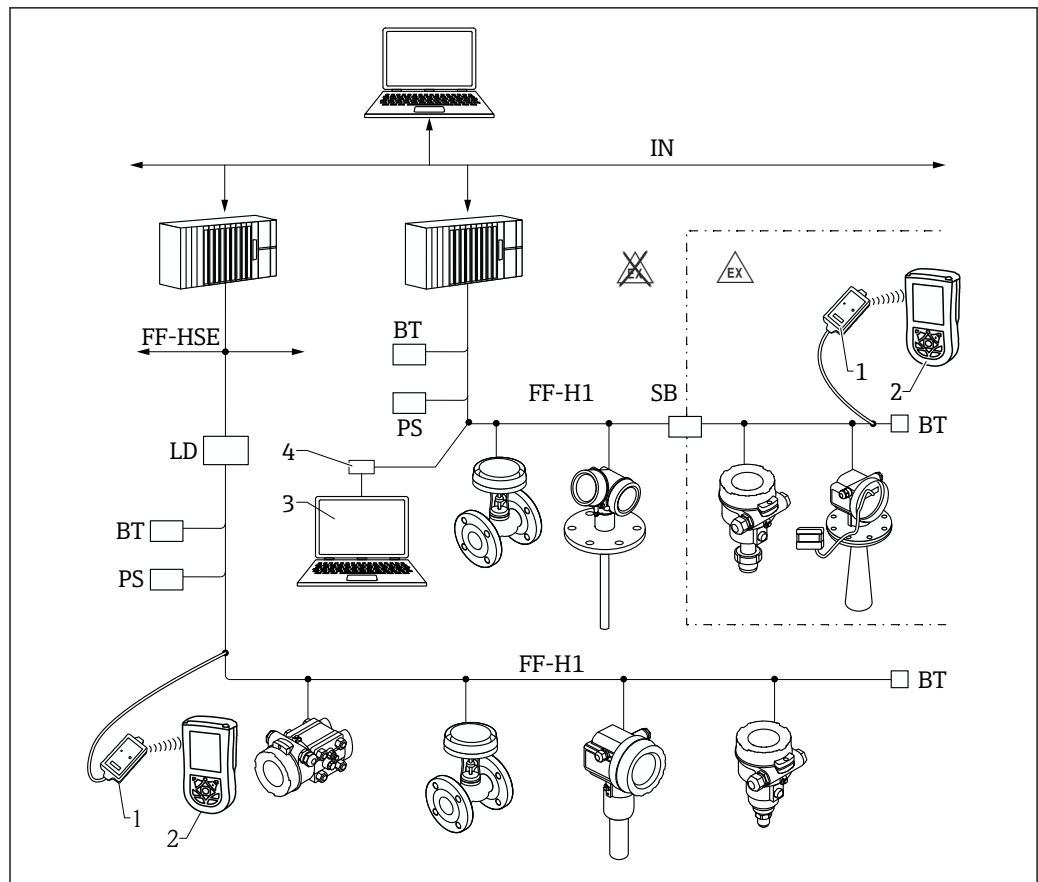

A0017188

41 FOUNDATION Fieldbus system architecture with associated components

- 1 FFblue Bluetooth modem
- 2 Field Xpert
- 3 DeviceCare/FieldCare
- 4 NI-FF interface card
- IN Industrial network
- FF- High Speed Ethernet
- HSE
- FF- FOUNDATION Fieldbus-H1
- H1
- LD Linking Device FF-HSE/FF-H1
- PS Bus Power Supply
- SB Safety barrier
- BT Bus Terminator

Via service interface (CDI)

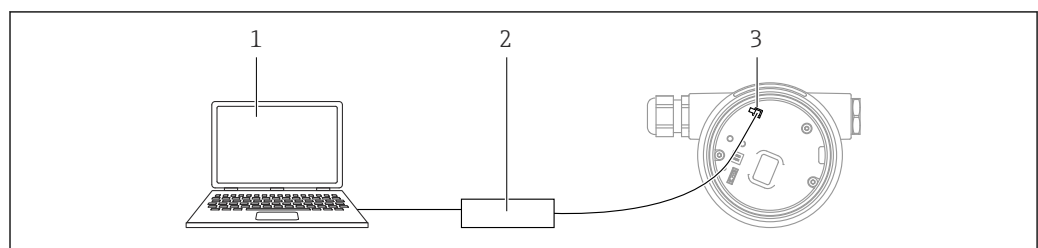

A0039148

- 1 Computer with FieldCare/DeviceCare operating tool
- 2 Commubox
- 3 Service interface (CDI) of the device (= Endress+Hauser Common Data Interface)

Operation via Bluetooth® wireless technology

Requirements

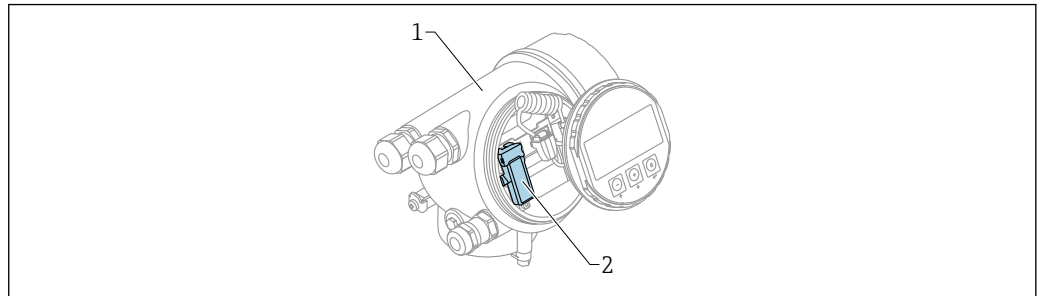

A0036790

42 Device with Bluetooth module

- 1 Electronics housing of the device
- 2 Bluetooth module

This operation option is only available for devices with Bluetooth module. There are the following options:

- The device has been ordered with a Bluetooth module:
Feature 610 "Accessory Mounted", option NF "Bluetooth"
- The Bluetooth module has been ordered as an accessory (ordering number: 71377355) and has been mounted. See Special Documentation SD02252F.

Operation via SmartBlue (app)

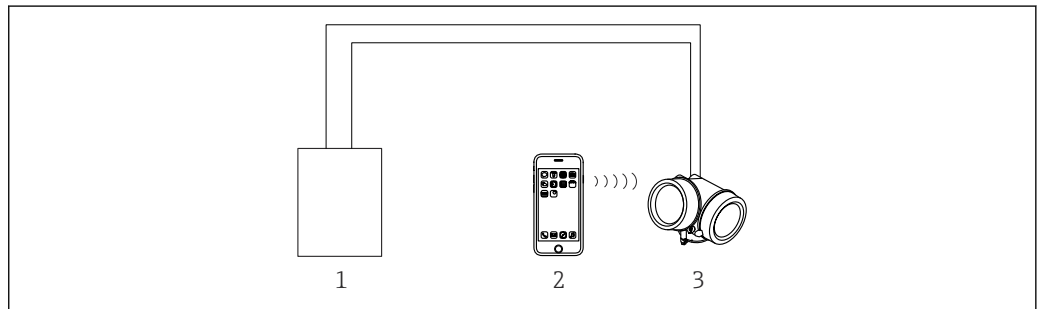

A0034939

43 Operation via SmartBlue (app)

- 1 Transmitter power supply unit
- 2 Smartphone / tablet with SmartBlue (app)
- 3 Transmitter with Bluetooth module

Integration in tank gauging

The Endress+Hauser Tank Side Monitor NRF81 features integrated communication functions for facilities with multiple tanks. One or more sensors can be installed on each tank, including radar sensors, point or average temperature sensors, capacitive probes for water detection, and/or pressure measuring cells. The Tank Side Monitor's multi-protocol capability ensures compatibility with virtually all industry-standard tank gauging protocols. Optional connectivity for 4 to 20 mA sensors, digital inputs/outputs, and analog outputs facilitates the full integration of all sensors on the tank. Use of the proven intrinsically safe HART bus concept for all sensors on the tank minimizes cabling costs while ensuring maximum safety, reliability, and performance.

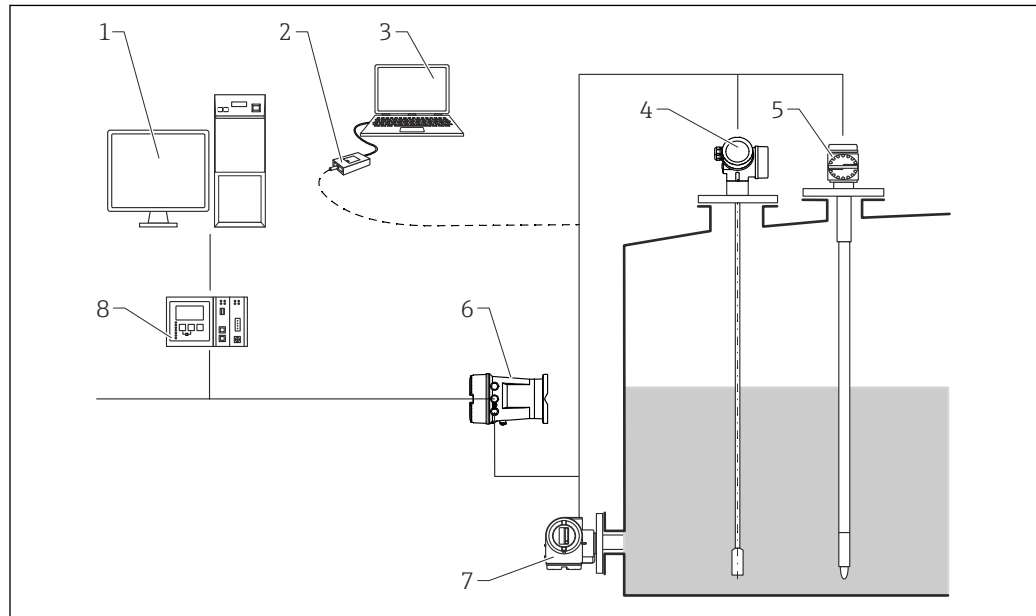

A0016590

44 The complete measuring system consists of:

- 1 Tankvision workspace
- 2 Commubox FXA195 (USB) - optional
- 3 Computer with operating tool (ControlCare) - optional
- 4 Level transmitter
- 5 Temperature measuring device
- 6 Tank Side Monitor NRF81
- 7 Pressure measuring instrument
- 8 Tankvision Tank Scanner NXA820

SupplyCare

SupplyCare is a web-based operating program for coordinating the flow of material and information along the supply chain. SupplyCare provides a comprehensive overview of the levels of geographically distributed tanks and silos, for instance, providing complete transparency over the current inventory situation, regardless of time and location.

Based on the measuring and transmission technology installed onsite, the current inventory data are collected and sent to SupplyCare. Critical levels are clearly indicated and calculated forecasts provide additional security for material requirements planning.

The main functions of SupplyCare:

Inventory visualization

SupplyCare determines the inventory levels in tanks and silos at regular intervals. It displays current and historical inventory data and calculated forecasts of future demand. The overview page can be configured to suit the user's preferences.

Master data management

With SupplyCare you can create and manage the master data for locations, companies, tanks, products and users, as well as user authorization.

Report Configurator

The Report Configurator can be used to create personalized reports quickly and easily. The reports can be saved in a variety of formats, such as Excel, PDF, CSV and XML. The reports can be transmitted in many ways, such as by http, ftp or e-mail.

Event management

Events, such as when levels drop below the safety stock level or plan points, are indicated by the software. In addition, SupplyCare can also notify pre-defined users by e-mail.

Alarms

If technical problems occur, e.g. connection issues, alarms are triggered and alarm e-mails are sent to the System Administrator and the Local System Administrator.

Delivery planning

The integrated delivery planning function automatically generates an order proposal if a pre-set minimum inventory level is undershot. Scheduled deliveries and disposals are monitored continuously by SupplyCare. SupplyCare notifies the user if scheduled deliveries and disposals are not going to be met as planned.

Analysis

In the Analysis module, the most important indicators for the inflow and outflow of the individual tanks are calculated and displayed as data and charts. Key indicators of material management are automatically calculated and form the basis for optimizing the delivery and storage process.

Geographical visualization

All the tanks and the tank inventories are represented graphically on a map (based on Google Maps). The tanks and inventory situations can be filtered by tank group, product, supplier or location.

Multi-language support

The multi-language user interface supports 9 languages, thereby enabling global collaboration on a single platform. The language and settings are recognized automatically using the browser settings.

SupplyCare Enterprise

SupplyCare Enterprise runs by default as a service under Microsoft Windows on an application server in an Apache Tomcat environment. The operators and administrators operate the application via a Web browser from their workstations.

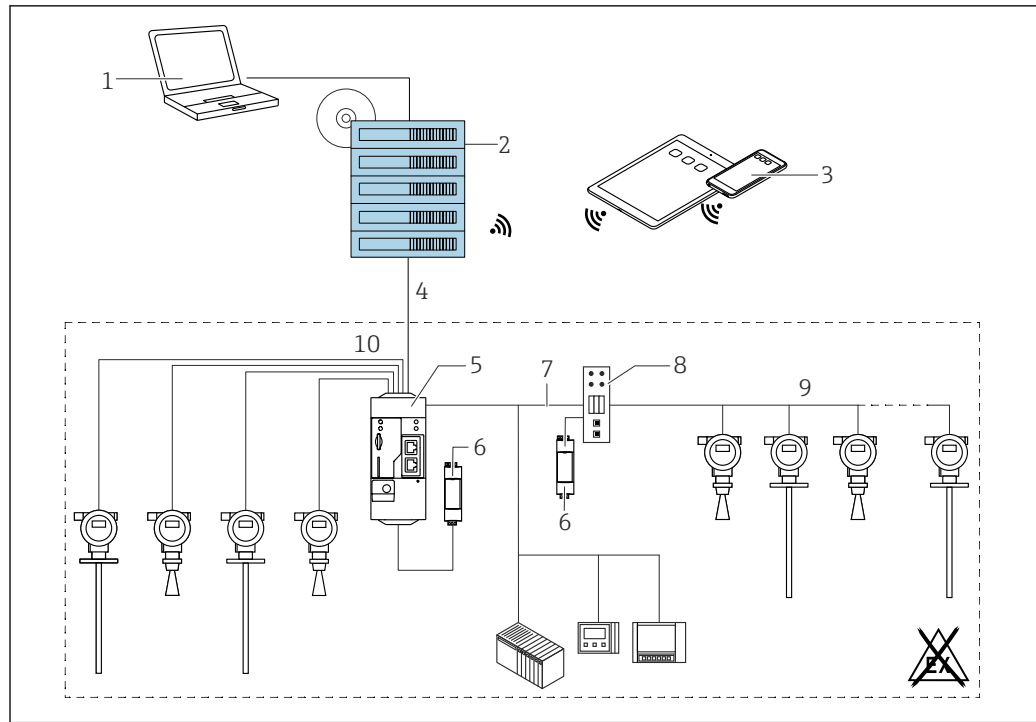

A0034288

45 Example of inventory management platform with SupplyCare Enterprise SCE30B

- 1 SupplyCare Enterprise (via Web browser)
- 2 SupplyCare Enterprise installation
- 3 SupplyCare Enterprise on mobile devices (via Web browser)
- 4 Ethernet/WLAN/UMTS
- 5 Fieldgate FXA42
- 6 Power supply 24 V_{DC}
- 7 Modbus TCP via Ethernet as server/client
- 8 Converter from Modbus to HART Multidrop
- 9 HART Multidrop
- 10 4 x analog input 4 to 20 mA (2-wire / 4-wire)

SupplyCare Hosting

SupplyCare Hosting is offered as a hosting service (software as a service). Here, the software is installed within the Endress+Hauser IT infrastructure and made available to the user in the Endress+Hauser portal.

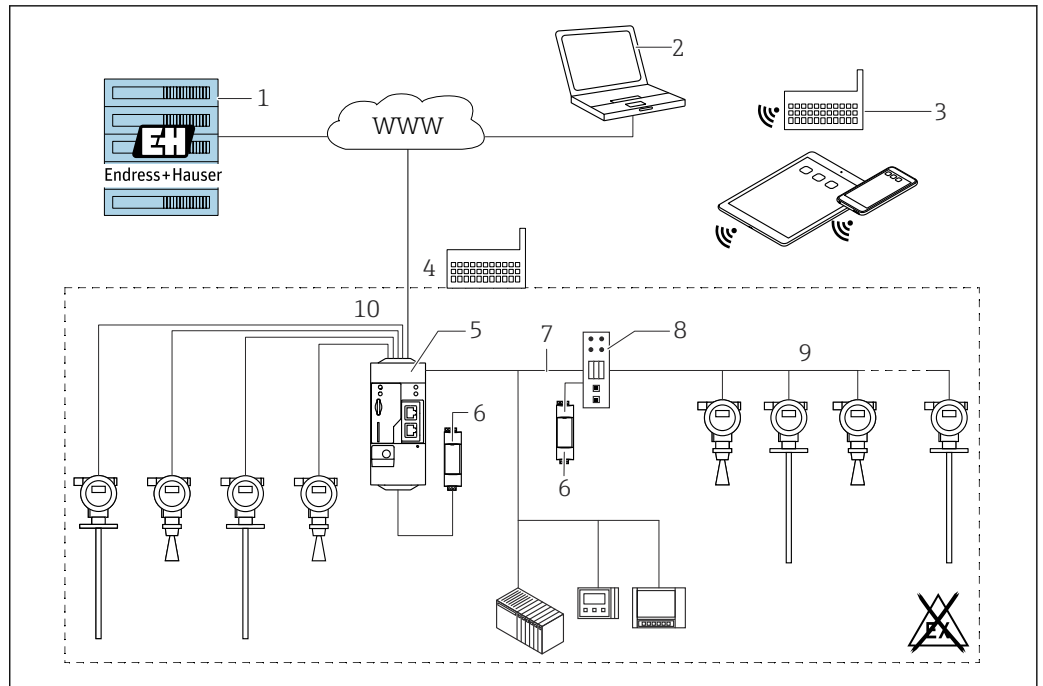

46 Example of inventory management platform with SupplyCare Hosting SCH30

- 1 SupplyCare Hosting installation in Endress+Hauser data center
- 2 PC workstation with Internet connection
- 3 Warehouse locations with Internet connection via 2G/3G with FXA42 or FXA30
- 4 Warehouse locations with Internet connection with FXA42
- 5 Fieldgate FXA42
- 6 Power supply 24 V_{DC}
- 7 Modbus TCP via Ethernet as server/client
- 8 Converter from Modbus to HART Multidrop
- 9 HART Multidrop
- 10 4 x analog input 4 to 20 mA (2-wire/4-wire)

In this case, users do not need to make the initial software purchase or install and run the IT infrastructure needed. Endress+Hauser constantly update SupplyCare Hosting and enhance the capability of the software in conjunction with the customer. The hosted version of SupplyCare is thus always up-to-date and can be customized to meet different customer requirements. Other services are also offered in addition to the IT infrastructure and the software that is installed in a secure, redundant Endress+Hauser data center. These services include defined availability of the global Endress+Hauser Service and Support Organization and defined response times in a service event.

Certificates and approvals

Current certificates and approvals for the product are available at www.endress.com on the relevant product page:

1. Select the product using the filters and search field.
2. Open the product page.
3. Select **Downloads**.

CE mark

The measuring system meets the legal requirements of the applicable EU directives. These are listed in the corresponding EU Declaration of Conformity together with the standards applied.

The manufacturer confirms successful testing of the device by affixing to it the CE mark.

RoHS

The measuring system meets the substance restrictions of the Directive on the Restriction of the Use of Certain Hazardous Substances 2011/65/EU (RoHS 2) and the Delegated Directive (EU) 2015/863 (RoHS 3).

RCM marking	<p>The supplied product or measuring system meets the ACMA (Australian Communications and Media Authority) requirements for network integrity, interoperability, performance characteristics as well as health and safety regulations. Here, especially the regulatory arrangements for electromagnetic compatibility are met. The products bear the RCM marking on the nameplate.</p>
Ex-approval	<p>The devices are certified for use in hazardous areas and the relevant safety instructions are provided in the separate "Safety Instructions" (XA, ZD) document. Reference is made to this document on the nameplate.</p> <p> The separate "Safety Instructions" documentation (XA) containing all the relevant explosion protection data is available from your Endress+Hauser sales organization.</p>
Dual seal ANSI/ISA 12.27.01	<p>The devices have been designed as dual seal devices in accordance with ANSI /ISA 12.27.01. This allows the user to forego the use of - and save the cost of installing - an external secondary process seal in the protection pipe as required in ANSI/NFPA 70 (NEC) and CSA 22.1 (CEC). These instruments comply with the North American installation practice and provide a very safe and cost-saving installation for pressurized applications with hazardous fluids.</p> <p>Please refer to the Safety Instructions (XA) of the relevant device for further information.</p>
Functional safety	<p>Use for level monitoring (MIN, MAX, range) up to SIL 3 (homogeneous redundancy), independently evaluated by TÜV Rheinland in accordance with IEC 61508, refer to the "Functional Safety Manual" SD00326F for more information.</p>
AD2000	<ul style="list-style-type: none"> ■ For FMP52/FMP55: The pressure retaining material 316L (1.4435/1.4404) corresponds to AD2000 - W2/W10. ■ Declaration of Conformity: see the product structure, feature 580, version JF.
NACE MR 0175 / ISO 15156	<ul style="list-style-type: none"> ■ The wetted, metal materials (excluding ropes) meet the requirements of NACE MR 0175 / ISO 15156. ■ Declaration of Conformity: see the product structure, feature 580, version JB
NACE MR 0103	<ul style="list-style-type: none"> ■ The wetted, metal materials (excluding ropes) meet the requirements of NACE MR 0103 / ISO 17495. ■ The Declaration of Conformity is based on NACE MR 0175. The hardness and intergranular corrosion have been tested, and heat treatment (solution annealed) has been performed. The materials used therefore meet the requirements of NACE MR 0103 / ISO 17495. ■ Declaration of Conformity: see the product structure, feature 580, version JE.
ASME B31.1 and B31.3	<ul style="list-style-type: none"> ■ The design, the material used, the pressure and temperature ranges and the labeling of the devices meet the requirements of ASME B31.1 and B31.3 ■ Declaration of Conformity: see the product structure, feature 580, version KV.
Pressure Equipment Directive	<p>Pressure equipment with permitted pressure ≤ 200 bar (2 900 psi)</p> <p>Pressure instruments with a process connection that does not have a pressurized housing do not fall within the scope of the Pressure Equipment Directive, irrespective of the maximum allowable pressure.</p> <p><i>Reasons:</i></p> <p>According to Article 2, point 5 of EU Directive 2014/68/EU, pressure accessories are defined as "devices with an operational function and having pressure-bearing housings".</p> <p>If a pressure instrument does not have a pressure-bearing housing (no identifiable pressure chamber of its own), there is no pressure accessory present within the meaning of the Directive.</p>



A0029561

Marine approval	Marine approval ¹⁾					
	Device	DNV GL	ABS	LR	BV	KR
	FMP55	✓	✓	✓	✓	-

1) See order code for 590 "Additional approval"

Radio approval Satisfies "Part 15" of the FCC rules for an unintentional radiator. All probes meet the requirements for a Class A digital device.
In addition, coaxial probes and all probes in metal vessels meet the requirements for a Class B digital device.

CRN approval Some device versions have CRN approval. Devices are CRN-approved if the following two conditions are met:

- The device has a CSA or FM approval (product structure: feature 010 "Approval")
- The device has a CRN-approved process connection according to the following table:

Feature 100 in the product structure	Approval
AEK	NPS 1-1/2" Cl. 150, PTFE > 316/316l flange ASME B16.5
AFK	NPS 2" C. 150, PTFE > 316/316l flange ASME B16.5
AGK	NPS 3" Cl. 150, PTFE > 316/316l flange ASME B16.5
AHK	NPS 4" Cl. 150, PTFE > 316/316l flange ASME B16.5
AJK	NPS 6" Cl. 150, PTFE > 316/316l flange ASME B16.5
AQK	NPS 1-1/2" Cl. 300, PTFE > 316/316l flange ASME B16.5
ARK	NPS 2" Cl. 300, PTFE > 316/316l flange ASME B16.5
ASK	NPS 3" Cl. 300, PTFE > 316/316l flange ASME B16.5
ATK	NPS 4" Cl. 300, PTFE > 316/316l flange ASME B16.5

-  Process connections that do not have CRN approval are not listed in this table.
- Please refer to the product structure to discover which process connections are available for a specific device type.
- CRN-approved devices are labeled with registration number OF14480.5C on the nameplate.

Test, certificate

Feature 580 "Test, certificate"	Description	Available for
Yes	3.1 Material documentation, wetted metal parts, EN10204-3.1 inspection certificate	FMP55
JB	Declaration of Conformity NACE MR0175, wetted metal parts	FMP55
JD	3.1 Material certificate, pressurized parts, EN10204-3.1 inspection certificate	FMP55
JE	Declaration of Conformity NACE MR0103, wetted metal parts	FMP55
JF	Declaration of Conformity AD2000, wetted metal parts: Material conformity for all metal wetted/pressurized parts according to AD2000 (data sheets W2, W9, W10)	FMP55
KE	Pressure test, internal procedure, inspection certificate	FMP55

Feature 580 "Test, certificate"	Description	Available for
KG	3.1 material certificate+PMI test (XRF), internal procedure, wetted metal parts, EN10204-3.1 inspection certificate	FMP55
KV	Declaration of Conformity ASME B31.3: The design, the material used, the pressure and temperature ranges and the labeling of the devices meet the requirements of ASME B31.3	FMP55

 Test reports, declarations and inspection certificates are available in electronic format in the *W@M Device Viewer*:

Enter the serial number from the nameplate (www.endress.com/deviceviewer)

This concerns the options for the following order codes:

- 550 "Calibration"
- 580 "Test, certificate"

Product documentation on paper A printed (hard copy) version of test reports, declarations and inspection certificates can optionally be ordered via order code 570 "Service", option I7 "Product documentation on paper". The documents are then supplied with the product.

External standards and guidelines

- EN 60529
Degrees of protection provided by enclosures (IP code)
- EN 61010-1
Safety requirements for electrical equipment for measurement, control and laboratory use
- IEC/EN 61326
"Emission in accordance with Class A requirements". Electromagnetic compatibility (EMC requirements)
- NAMUR NE 21
Electromagnetic compatibility (EMC) of industrial process and laboratory control equipment
- NAMUR NE 43
Standardization of the signal level for the breakdown information of digital transmitters with analog output signal.
- NAMUR NE 53
Software of field devices and signal-processing devices with digital electronics
- NAMUR NE 107
Status classification as per NE107
- NAMUR NE 131
Requirements for field devices for standard applications
- IEC61508
Functional safety of safety-related electrical/electronic/programmable electronic systems

Ordering information

Detailed ordering information is available from your nearest sales organization www.addresses.endress.com or in the Product Configurator at www.endress.com:

1. Select the product using the filters and search field.
2. Open the product page.
3. Select **Configuration**.

 **Product Configurator - the tool for individual product configuration**

- Up-to-the-minute configuration data
- Depending on the device: Direct input of measuring point-specific information such as measuring range or operating language
- Automatic verification of exclusion criteria
- Automatic creation of the order code and its breakdown in PDF or Excel output format
- Ability to order directly in the Endress+Hauser Online Shop

3-point linearity protocol  The following points must be considered if the order option 3-point linearity protocol was selected under the Calibration feature.

The 3 points of the linearity protocol are defined as follows, depending on the selected probe:

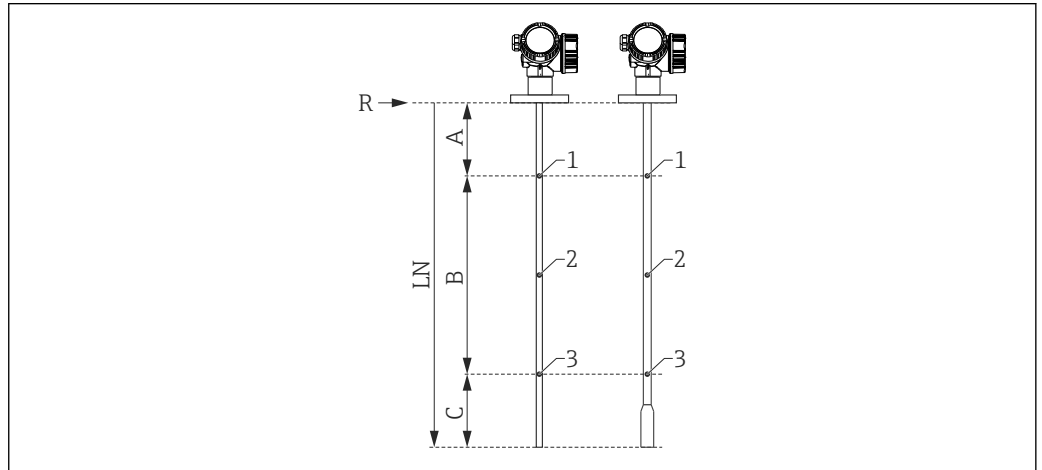

- A Distance from the reference point R to the first measuring point
- B Measuring range
- C Distance from the probe end to the third measuring point
- LN Probe length
- R Reference point of measurement
- 1 First measuring point
- 2 Second measuring point (in the middle between the first and third measuring point)
- 3 Third measuring point

	Rod or coaxial probe LN ≤ 6 m (20 ft)	Separable rod probe LN > 6 m (20 ft)	Rope probe LN ≤ 6 m (20 ft)	Rope probe LN > 6 m (20 ft)
Position of 1st measuring point	<ul style="list-style-type: none"> ▪ FMP51/FMP52/FMP54 without gas phase compensation/FMP55: A = 350 mm (13.8 in) ▪ FMP54 with gas phase compensation, L_{ref} = 300 mm (11 in): A = 600 mm (23.6 in) ▪ FMP54 with gas phase compensation, L_{ref} = 550 mm (21 in): A = 850 mm (33.5 in) 		A = 350 mm (13.8 in)	A = 350 mm (13.8 in)
Position of 2nd measuring point	In the middle between the 1st and 3rd measuring point			
Position of 3rd measuring point	Measured from bottom: C = 250 mm (9.84 in)	Measured from top: A+B = 5 750 mm (226 in)	Measured from bottom: C = 500 mm (19.7 in)	Measured from top: A+B = 5 500 mm (217 in)
Minimum measuring range	B ≥ 400 mm (15.7 in)	B ≥ 400 mm (15.7 in)	B ≥ 400 mm (15.7 in)	B ≥ 400 mm (15.7 in)
Minimum probe length	LN ≥ 1 000 mm (39.4 in)	LN ≥ 1 000 mm (39.4 in)	LN ≥ 1 250 mm (49.2 in)	LN ≥ 1 250 mm (49.2 in)

- The position of the measuring points can vary by ±1 cm (±0.04 in).
- In the case of rod and rope probes, the linearity check is performed with the entire device.
 - In the case of coaxial probes, the device electronics unit is mounted on a reference rod probe during the test and the linearity check is performed.
 - The linearity check is performed under reference operating conditions.

5-point linearity protocol

- The following points must be considered if the order option 5-point linearity protocol was selected under the Calibration feature.

The 5 points of the linearity protocol are evenly distributed over the measuring range (0% - 100%). The **Empty calibration** (E) and **Full calibration** (F) must be specified to define the measuring range. If this information is missing, probe-dependent default values are used instead.

The following restrictions must be considered when selecting E and F:

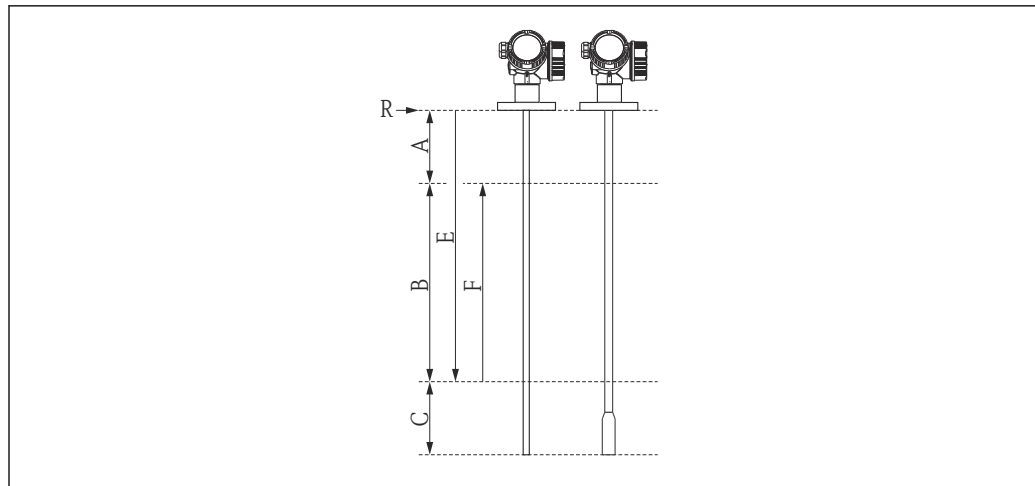

A0014673

- A Distance from the reference point R to the 100% mark
- B Measuring range
- C Distance from the probe end to the 0% mark
- E Empty calibration
- F Full calibration
- R Reference point of measurement

Sensor	Minimum distance between reference point R and 100% mark	Minimum measuring range
FMP55	A ≥ 250 mm (10 in)	B ≥ 100 mm (4 in)

Probe type	Minimum distance from the probe end to the 0% mark	Maximum value for "Empty calibration"
Rod	C ≥ 100 mm (4 in)	E ≤ 3.9 m (12.8 ft)
Coax	C ≥ 100 mm (4 in)	E ≤ 5.9 m (19.4 ft)
Rope	C ≥ 1000 mm (40 in)	E ≤ 9 m (29 ft)

- i** In the case of rod and rope probes, the linearity check is performed with the entire device.
- i** In the case of coaxial probes, the device electronics unit is mounted on a reference rod probe during the test and the linearity check is performed.
- i** The linearity check is performed under reference operating conditions.
- i** The selected values for **Empty calibration** and **Full calibration** are only used to create the linearity protocol. Afterwards, the values are reset to the default values specific for the probe. If values other than the default values are required, they must be ordered as a customized parameterization.

Customer-specific configuration

If the order option "Customized parameterization HART", "Customized parameterization PA" or "Customized parameterization FF" has been selected in feature "Service", presettings that differ from the default settings can be selected for the following parameters:

Parameter	Communication protocol	Picklist/value range
Setup → Unit of length	<ul style="list-style-type: none"> ▪ HART ▪ PA ▪ FF 	<ul style="list-style-type: none"> ▪ in ▪ ft ▪ mm ▪ m
Setup → Empty calibration	<ul style="list-style-type: none"> ▪ HART ▪ PA ▪ FF 	0 to 10 m (0 to 30 ft)
Setup → Full calibration	<ul style="list-style-type: none"> ▪ HART ▪ PA ▪ FF 	0 to 10 m (0 to 30 ft)
Setup → Advanced setup → Curr. output 1/2 → Damping	HART	0 to 999.9 s

Parameter	Communication protocol	Picklist/value range
Setup → Advanced setup → Curr. output 1/2 → Failure mode	HART	<ul style="list-style-type: none"> ▪ Min ▪ Max ▪ Last valid value
Expert → Comm. → HART config. → Burst mode	HART	<ul style="list-style-type: none"> ▪ Off ▪ On

Labeling (optional)

Various types of measuring point labeling can be selected in the Product Configurator.

This includes:

- Tag
- Adhesive label
- RFID TAG
- Labeling according to DIN91406, also with NFC.

Tag name

3 lines with a maximum of 18 characters per line

Labeling in the electronic nameplate (ENP)

The first 32 characters of the tag name

Labeling on the display module

The first 12 characters of the tag name

Application packages

Heartbeat Diagnostics

Availability

Available in all device versions.

Function

- Continuous self-monitoring of the device.
- Diagnostic messages output to
 - the local display.
 - an asset management system (e.g. FieldCare/DeviceCare).
 - an automation system (e.g. PLC).

Advantages

- Device condition information is available immediately and processed in time.
- The status signals are classified in accordance with VDI/VDE 2650 and NAMUR recommendation NE 107 and contain information about the cause of the error and remedial action.

Detailed description

See the "Diagnostics and troubleshooting" section of the Operating Instructions for the device.

Heartbeat Verification

Availability

Available for the following versions of feature 540 "Application package":

- **EH**
Heartbeat Verification + Monitoring
- **EJ**
Heartbeat Verification

Device functionality checked on demand

- Verification of the correct functioning of the device within specifications.
- The verification result provides information about the condition of the device: **Passed** or **Failed**.
- The results are documented in a verification report.
- The automatically generated report supports the obligation to demonstrate compliance with internal and external regulations, laws and standards.
- Verification is possible without interrupting the process.

Advantages

- Onsite access to the device is not required to use the functionality.
- The DTM triggers verification in the device and interprets the results. No specific knowledge is required on the part of the user.
(DTM: Device Type Manager; controls device operation via DeviceCare, FieldCare or a DTM-based process control system.)
- The verification report can be used to prove quality measures to a third party.
- **Heartbeat Verification** can replace other maintenance tasks (e.g. periodic check) or extend the test intervals.

SIL/WHG-locked devices

Only relevant for devices with SIL or WHG approval: order code 590 ("Additional approval"), option LA ("SIL") or LC ("WHG").

- The **Heartbeat Verification** module contains a wizard for the proof test which must be performed at appropriate intervals for the following applications:
 - SIL (IEC61508/IEC61511)
 - WHG (German Water Resources Act)
- To perform a proof test, the device must be locked (SIL/WHG locking).
- The wizard can be used via FieldCare, DeviceCare or a DTM-based process control system.



In the case of SIL-locked and WHG-locked devices, it is **not** possible to perform verification without taking additional measures (e.g. bridging the output current) because the output current must be simulated (Increased safety mode) or the level must be approached manually (Expert mode) during subsequent re-locking (SIL/WHG locking).

Detailed description



SD01872F

Heartbeat Monitoring

Availability

Available for the following versions of feature 540 "Application package":

EH

Heartbeat Verification + Monitoring

Function

- In addition to the verification parameters, the corresponding parameter values are also logged.
- Existing measured variables, such as the echo amplitude, are used in the **Foam detection** and **Build-up detection** wizards.



In the Levelflex FMP5x, the **Foam detection** and **Build-up detection** wizards cannot be used together.

"Foam detection" wizard

- The Heartbeat Monitoring module contains the **Foam detection** wizard.
- This wizard is used to configure automatic foam detection, which detects foam on the product surface on the basis of the reduced signal amplitude. Foam detection can be linked to a switch output in order to control a sprinkler system, for example, which dissolves the foam.
- This wizard can be used via FieldCare, DeviceCare or a DTM-based process control system.

"Build-up detection" wizard

- The Heartbeat Monitoring module contains the **Build-up detection** wizard.
- The wizard is used to configure automatic buildup detection, which detects the buildup of deposits on the probe on the basis of the reduced signal amplitude.
- This wizard can be used via FieldCare, DeviceCare or a DTM-based process control system.

Advantages

- Early detection of changes (trends) to ensure plant availability and product quality.
- Use of information for the proactive planning of measures (e.g. cleaning/maintenance).
- Identification of undesirable process conditions as the basis to optimizing the facility and the processes.
- Automated control of measures to remove foam or buildup.

Detailed description



Accessories

The accessories currently available for the product can be selected at www.endress.com:

1. Select the product using the filters and search field.
2. Open the product page.
3. Select **Spare parts & Accessories**.

Device-specific accessories

Weather protection cover

The weather protection cover can be ordered together with the device via the "Accessory enclosed" product structure.

It is used to protect against direct sunlight, precipitation and ice.

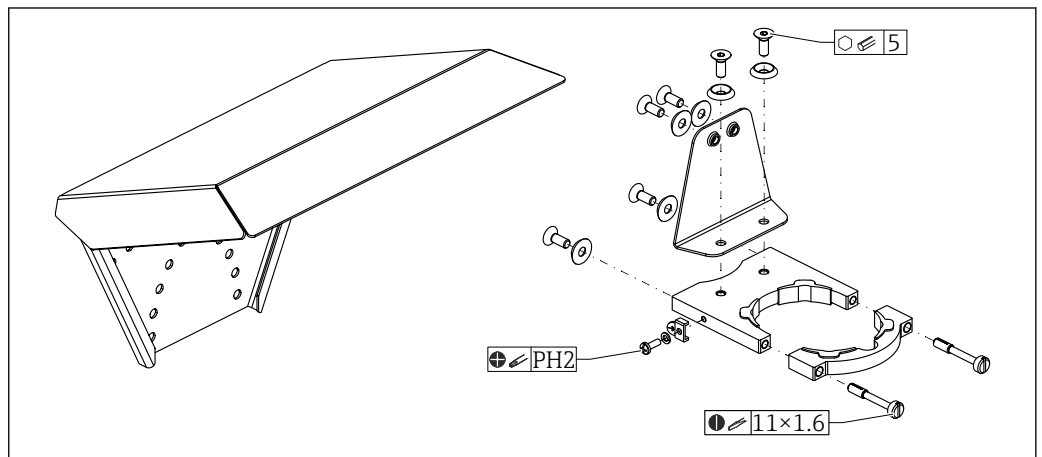

47 Overview

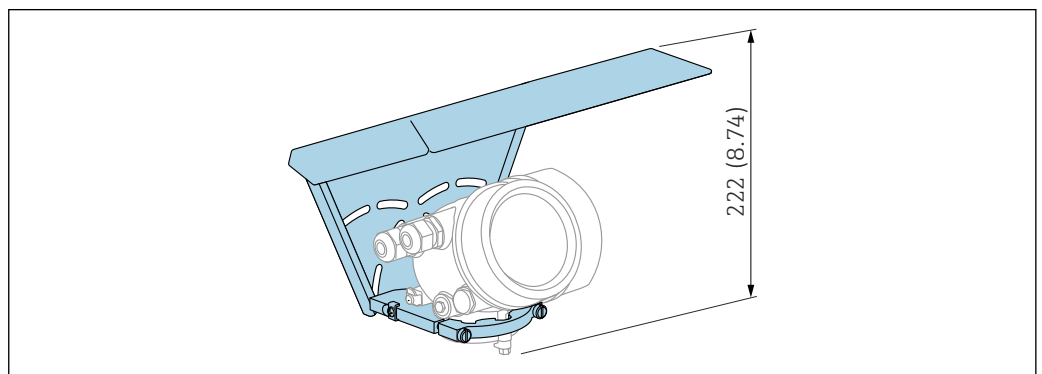

48 Height. Unit of measurement mm (in)

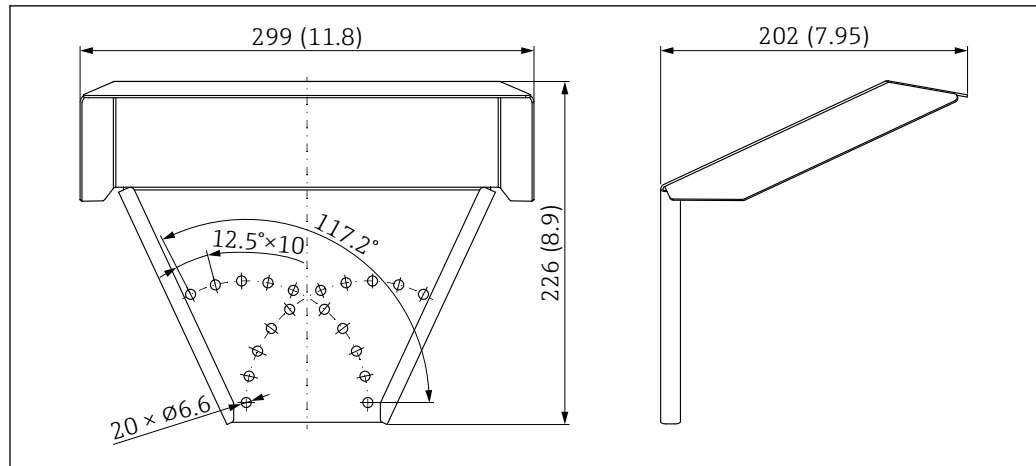

A0015472

49 Dimensions. Unit of measurement mm (in)

Material

- Protection cap; 316L (1.4404)
- Bracket; 316L (1.4404)
- Angle bracket; 316L (1.4404)
- Clamping screw; 316L (1.4404) + carbon fiber
- Molded rubber part (4x); EPDM
- Screws; A4
- Disks; A4
- Ground terminal; A4, 316L (1.4404)

Order number for accessories:

71162242

Mounting bracket for electronics housing

With "remote sensor" device versions (feature 060 in the product structure), the mounting bracket is included in the scope of delivery. It can be ordered as a separate accessory .

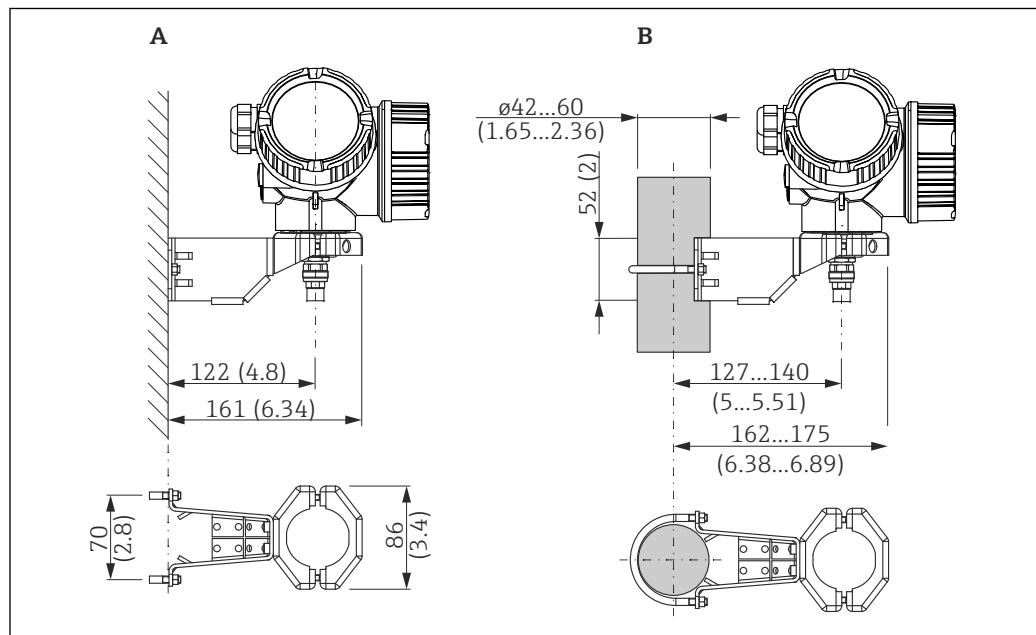

A0014793

50 Mounting bracket for electronics housing; unit: mm (in)

A Wall mounting

B Post mounting

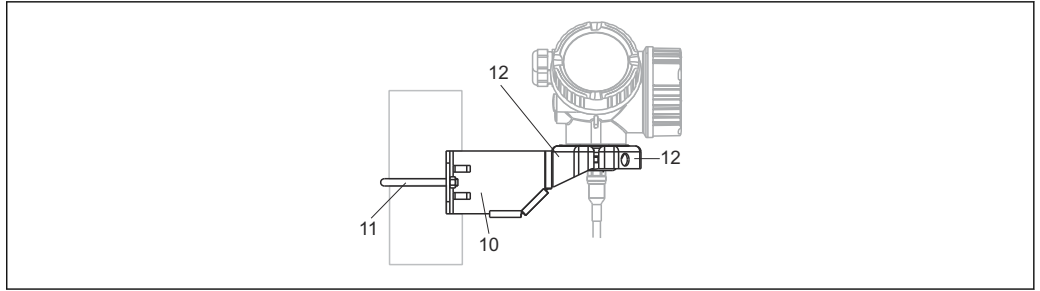

A0015143

51 Material; mounting bracket

10 Bracket, 316L (1.4404)

11 Round bracket, 316L (1.4404); screws/nuts, A4-70; distance sleeves, 316L (1.4404)

12 Half-shells, 316 L (1.4404)

Order number for accessories:

71102216

Centering star

Centering star PFA

Suitable for:

FMP55

Available versions:

- \varnothing 16.4 mm (0.65 in)
- \varnothing 37 mm (1.46 in)

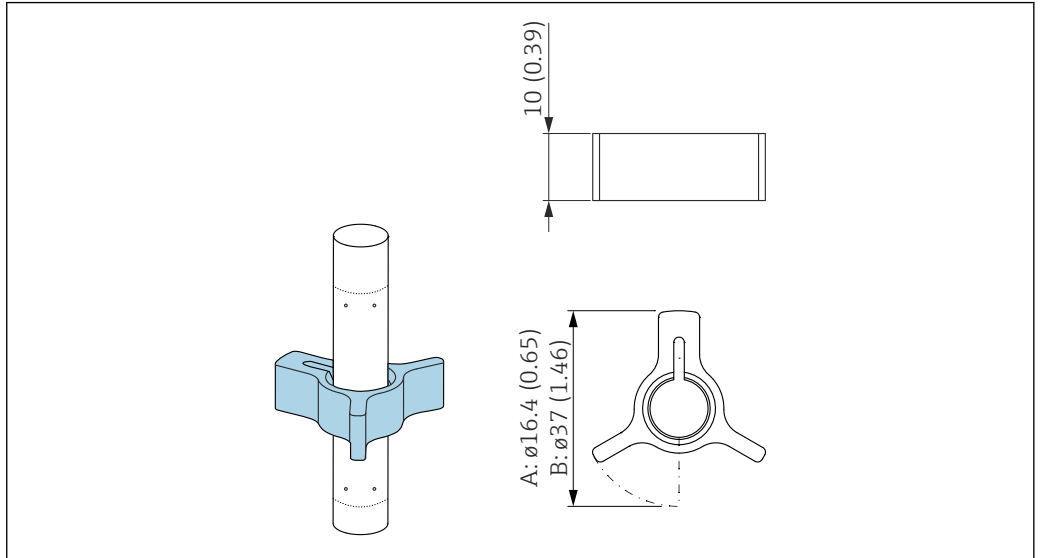

A0014577

A For probe 8 mm (0.3 in)

B For probes 12 mm (0.47 in) and 16 mm (0.63 in)

The centering star is suitable for probes with a rod diameter of 8 mm (0.3 in), 12 mm (0.47 in) and 16 mm (0.63 in) (including coated rod probes) and can be used in pipes from DN40 to DN50.

 For details, see BA00378F.

- Material: PFA
- Permitted process temperature range: -200 to +250 °C (-328 to +482 °F)

Order number for accessories:

- Probe 8 mm (0.3 in)
71162453
- Probe 12 mm (0.47 in)
71157270
- Probe 16 mm (0.63 in)
71069065

i The PFA centering star can also be ordered directly with the device (Levelflex product structure, feature 610 "Accessory mounted", option OE).

Centering star PEEK, Ø 48 to 95 mm (1.9 to 3.7 in)

Suitable for:
FMP55

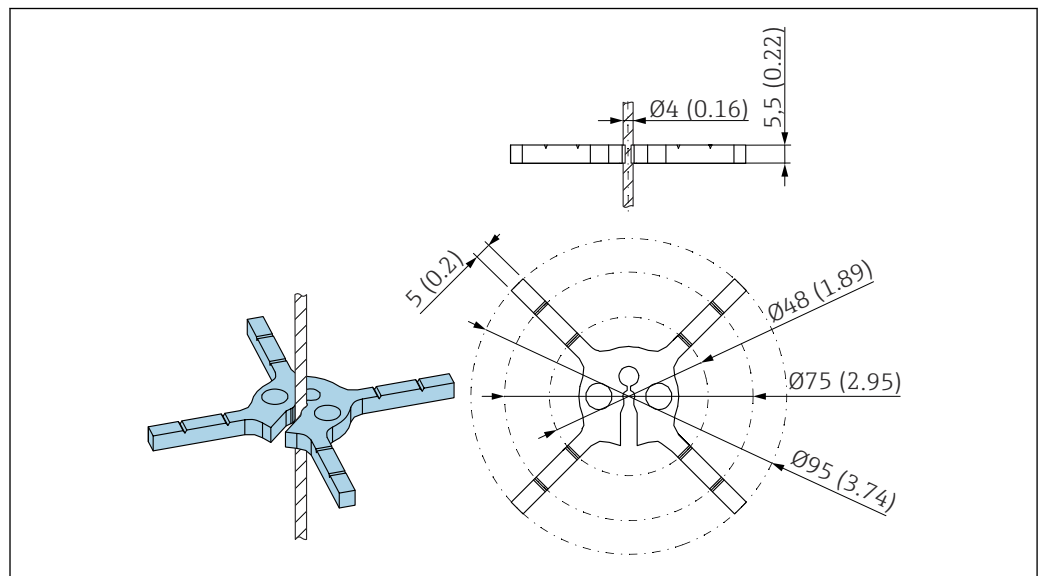

A0035182

The centering star is suitable for probes with a rope diameter of 4 mm ($\frac{1}{8}$ in) (including coated rope probes).

b For details, see SD01961F.

- Material: PEEK
- Permitted process temperature range: -60 to +250 °C (-76 to +482 °F)

Order number for accessories:

- 71373490 (1x)
- 71373492 (5x)

Remote display FHX50

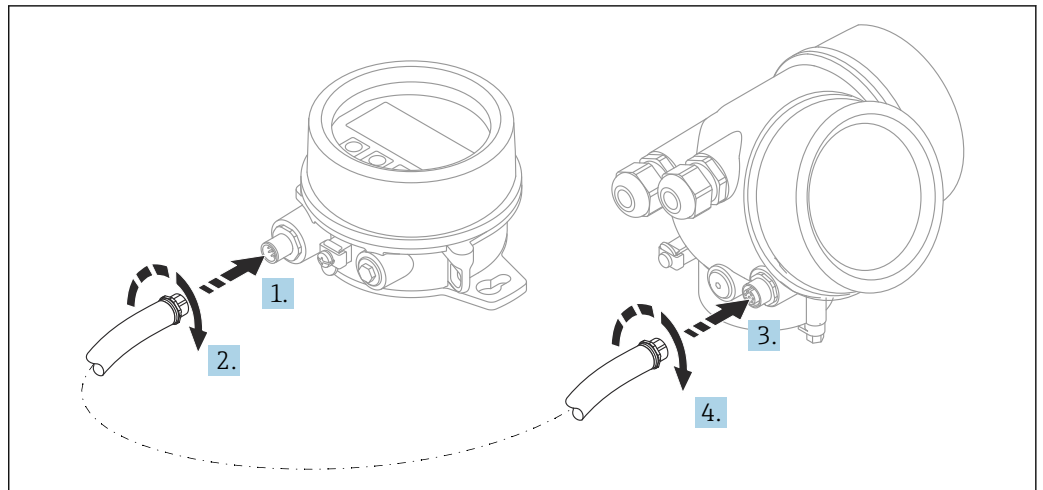

A0019128

Technical data

- Material:
 - Plastic PBT
 - 316L/1.4404
 - Aluminum
 - Degree of protection: IP68 / NEMA 6P and IP66 / NEMA 4x
 - Suitable for display modules:
 - SD02 (push buttons)
 - SD03 (touch control)
 - Connecting cable:
 - Cable supplied with device up to 30 m (98 ft)
 - Standard cable provided by customer onsite up to 60 m (196 ft)
 - Ambient temperature: -40 to 80 °C (-40 to 176 °F)
 - Ambient temperature, optionally available for order. -50 to 80 °C (-58 to 176 °F)
- NOTICE** If the temperature is permanently below -40 °C (-40 °F), higher failure rates can be expected.

Ordering information

- If the remote display is to be used, the device version "Prepared for display FHX50" must be ordered.
For FHX50, the option "Prepared for display FHX50" must be selected under "Measuring device version".
- If a measuring instrument has not been ordered with the version "Prepared for display FHX50" and is to be retrofitted with an FHX50, the version "Not prepared for display FHX50" must be ordered for the FHX50 under "Measuring device version". In this case, a retrofit kit for the device is supplied with the FHX50. The kit can be used to prepare the device so that the FHX50 can be used.

i Use of the FHX50 may be restricted for transmitters with an approval. A device can only be retrofitted with the FHX50 if the option "Prepared for FHX50" is listed under *Basic specifications*, "Display, operation" in the Safety instructions (XA) for the device.

Also refer to the Safety Instructions (XA) of the FHX50.

Retrofitting is not possible on transmitters with:

- An approval for use in areas with flammable dust (dust ignition-proof approval)
- Type of protection Ex nA

b For details, see "Special Documentation" document SD01007F.

Surge arrester

The surge arrester for loop-powered devices can be ordered together with the device via the "Accessory mounted" section of the product order structure.

The surge arrester can be used for loop-powered devices.

- 1-channel devices - OVP10
- 2-channel devices - OVP20

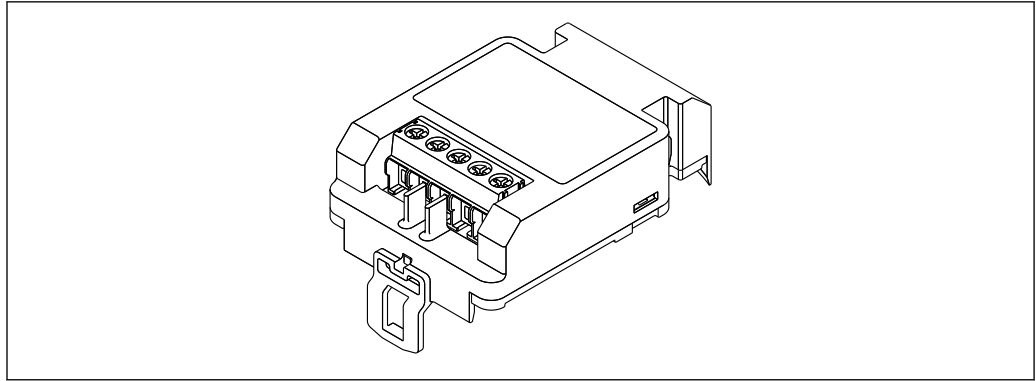

A0021734

Technical data

- Resistance per channel: $2 \times 0.5 \Omega_{\max}$
- Threshold DC voltage: 400 to 700 V
- Threshold surge voltage: $< 800 \text{ V}$
- Capacitance at 1 MHz: $< 1.5 \text{ pF}$
- Nominal leakage current (8/20 μs): 10 kA
- Suitable for conductor cross-sections: 0.2 to 2.5 mm² (24 to 14 AWG)

If retrofitting:

- Order number for 1-channel devices (OVP10): 71128617
- Order number for 2-channel devices (OVP20): 71128619
- The use of the OVP module may be restricted depending on the transmitter approval. A device may only be retrofitted with the OVP module if the option *NA* (overvoltage protection) is listed under *Optional specifications* in the Safety Instructions (*XA*) associated with the device.
- In order to keep the necessary safety distances when using the surge arrester module, the housing cover also needs to be replaced when the device is retrofitted.

Depending on the housing type, the suitable cover can be ordered using the following order number:

- Housing GT18: 71185516
- Housing GT19: 71185518
- Housing GT20: 71185517



For details, see the "Special Documentation" SD01090F

Bluetooth module BT10 for HART devices

The Bluetooth module BT10 can be ordered together with the device via the "Accessory mounted" section of the product order structure.

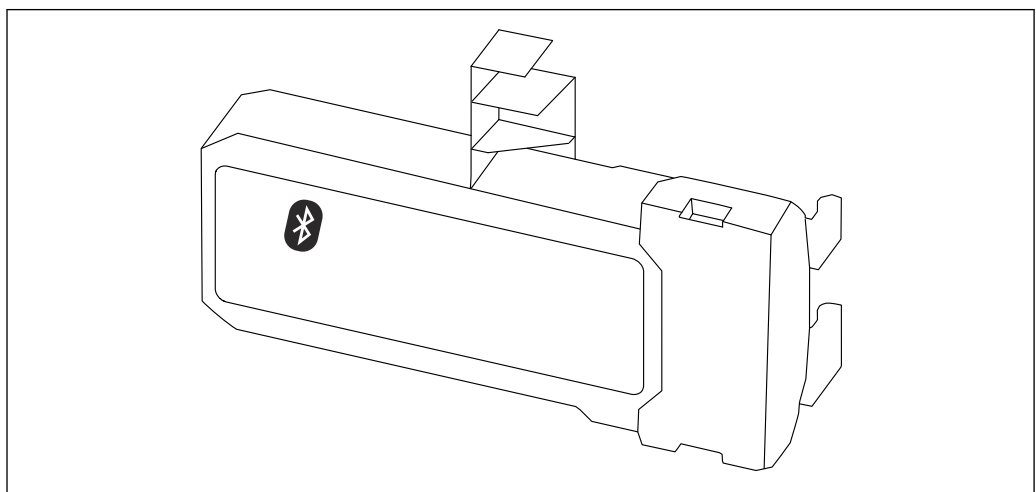

A0036493

Technical data

- Quick and easy setup with the SmartBlue app
- No additional tools or adapters needed
- Signal curve via SmartBlue (app)
- Encrypted single point-to-point data transmission (tested by Fraunhofer Institute) and password-protected communication via Bluetooth® wireless technology
- Range under reference conditions:
> 10 m (33 ft)
- When the Bluetooth module is used, the minimum supply voltage of the device increases by up to 3 V.

If retrofitting:

- Order number: 71377355
- The use of the Bluetooth module may be restricted depending on the transmitter approval. A device may only be retrofitted with the Bluetooth module if the option *NF* (Bluetooth module) is listed under *Optional specifications* in the Safety Instructions (XA) associated with the device.

 For details, see the "Special Documentation" SD02252F

Communication-specific accessories

Commubox FXA195 HART

For intrinsically safe HART communication with FieldCare via the USB interface

 For details, see "Technical Information" TI00404F

Commubox FXA291

Connects Endress+Hauser field devices with a CDI interface (= Endress+Hauser Common Data Interface) and the USB port of a computer or laptop

Order number: 51516983

 For details, see "Technical Information" TI00405C

HART Loop Converter HMX50

Is used to evaluate and convert dynamic HART process variables to analog current signals or limit values

Order number: 71063562

 For details, see "Technical Information" TI00429F and Operating Instructions BA00371F

WirelessHART adapter SWA70

- Is used for the wireless connection of field devices
- The WirelessHART adapter can be easily integrated into field devices and existing infrastructures, offers data protection and transmission safety and can be operated in parallel with other wireless networks

 For details, see Operating Instructions BA00061S

Fieldgate FXA42

Fieldgates enable communication between connected 4 to 20 mA, Modbus RS485 and Modbus TCP devices and SupplyCare Hosting or SupplyCare Enterprise. The signals are transmitted either via Ethernet TCP/IP, WLAN or mobile communications (UMTS). Advanced automation capabilities are available, such as an integrated Web-PLC, OpenVPN and other functions.

 For details, see "Technical Information" TI01297S and Operating Instructions BA01778S.

SupplyCare Enterprise SCE30B

Inventory management software that displays the level, volume, mass, temperature, pressure, density or other parameters of tanks. The parameters are recorded and transmitted by means of gateways like Fieldgate FXA42, Connect Sensor FXA30B or other gateway types. This Web-based software is installed on a local server and can also be visualized and operated with mobile terminals such as a smartphone or tablet.

 For details, see Technical Information TI01228S and Operating Instructions BA00055S

SupplyCare Hosting SCH30

Inventory management software that displays the level, volume, mass, temperature, pressure, density or other parameters of tanks. The parameters are recorded and transmitted by means of gateways like Fieldgate FXA42, Connect Sensor FXA30B or other gateway types.

SupplyCare Hosting is offered as a hosting service (Software as a Service, SaaS). In the Endress+Hauser portal, the user is provided with the data over the Internet.



For details, see Technical Information TI01229S and Operating Instructions BA00050S

Field Xpert SFX350

Field Xpert SFX350 is a mobile computer for commissioning and maintenance. It enables efficient device configuration and diagnostics for HART and FOUNDATION Fieldbus devices in the **non-Ex** area.



For details, see Operating Instructions BA01202S

Field Xpert SFX370

Field Xpert SFX370 is a mobile computer for commissioning and maintenance. It enables efficient device configuration and diagnostics for HART and FOUNDATION Fieldbus devices in the **non-Ex** area and the **Ex** area.



For details, see Operating Instructions BA01202S

Service-specific accessories**DeviceCare SFE100**

Configuration tool for HART, PROFIBUS and FOUNDATION Fieldbus field devices



Technical Information TI01134S

FieldCare SFE500

FDT-based plant asset management tool

It can configure all smart field units in your system and helps you manage them. By using the status information, it is also a simple but effective way of checking their status and condition.



Technical Information TI00028S

System components**Memograph M RSG45**

The Advanced Data Manager is a flexible and powerful system for organizing process values.

The Memograph M is used for electronic acquisition, display, recording, analysis, remote transmission and archiving of analog and digital input signals as well as calculated values.



Technical Information TI01180R and Operating Instructions BA01338R

RN42

Single-channel active barrier with wide-range power supply for safe electrical isolation of 4 to 20 mA standard signal circuits, HART transparent.



Technical Information TI01584K and Operating Instructions BA02090K

Documentation

The following document types are available in the Downloads area of the Endress+Hauser website (www.endress.com/downloads), depending on the device version:

Document type	Purpose and content of the document
Technical Information (TI)	Planning aid for your device The document contains all the technical data on the device and provides an overview of the accessories and other products that can be ordered for the device.
Brief Operating Instructions (KA)	Guide that takes you quickly to the 1st measured value The Brief Operating Instructions contain all the essential information from incoming acceptance to initial commissioning.
Operating Instructions (BA)	Your reference document The Operating Instructions contain all the information that is required in various phases of the life cycle of the device: from product identification, incoming acceptance and storage, to mounting, connection, operation and commissioning through to troubleshooting, maintenance and disposal.
Description of Device Parameters (GP)	Reference for your parameters The document provides a detailed explanation of each individual parameter. The description is aimed at those who work with the device over the entire life cycle and perform specific configurations.
Safety instructions (XA)	Depending on the approval, safety instructions for electrical equipment in hazardous areas are also supplied with the device. These are an integral part of the Operating Instructions.  The nameplate indicates which Safety Instructions (XA) apply to the device.
Supplementary device-dependent documentation (SD/FY)	Always comply strictly with the instructions in the relevant supplementary documentation. The supplementary documentation is a constituent part of the device documentation.



71685194

www.addresses.endress.com
