

# Operating Instructions

## L20222

Temperature transmitter  
with HART<sup>®</sup> protocol





## Table of contents

<b>1</b>	<b>About this document</b> .....	<b>4</b>	<b>8</b>	<b>Commissioning</b> .....	<b>29</b>
1.1	Document function .....	4	8.1	Function check .....	29
1.2	Safety instructions .....	4	8.2	Switching on the device .....	29
1.3	Symbols used .....	4	8.3	Protecting settings from unauthorized access .	30
1.4	Tool symbols .....	5	<b>9</b>	<b>Diagnostics and troubleshooting</b> ...	<b>31</b>
1.5	Registered trademarks .....	6	9.1	General troubleshooting .....	31
<b>2</b>	<b>Basic safety instructions</b> .....	<b>6</b>	9.2	Diagnostic information on local display .....	33
2.1	Requirements of the personnel .....	6	9.3	Diagnostic information via communication interface .....	33
2.2	Intended use .....	6	9.4	Diagnostic list .....	34
2.3	Workplace safety .....	6	9.5	Event logbook .....	34
2.4	Operational safety .....	6	9.6	Overview of diagnostic events .....	34
2.5	Product safety .....	7	<b>10</b>	<b>Maintenance and cleaning</b> .....	<b>36</b>
2.6	IT security .....	7	10.1	Cleaning of surfaces not in contact with the medium .....	36
<b>3</b>	<b>Incoming acceptance and product identification</b> .....	<b>7</b>	<b>11</b>	<b>Repair</b> .....	<b>37</b>
3.1	Incoming acceptance .....	7	11.1	General notes .....	37
3.2	Product identification .....	8	11.2	Spare parts .....	37
3.3	Storage and transport .....	8	11.3	Return .....	37
<b>4</b>	<b>Installation</b> .....	<b>9</b>	11.4	Disposal .....	37
4.1	Installation requirements .....	9	<b>12</b>	<b>Accessories</b> .....	<b>37</b>
4.2	Installing the device .....	9	<b>13</b>	<b>Technical data</b> .....	<b>38</b>
4.3	Post-installation check .....	14	13.1	Input .....	38
<b>5</b>	<b>Electrical connection</b> .....	<b>15</b>	13.2	Output .....	39
5.1	Connection requirements .....	15	13.3	Power supply .....	40
5.2	Quick wiring guide .....	16	13.4	Performance characteristics .....	41
5.3	Connecting the sensor .....	17	13.5	Ambient conditions .....	48
5.4	Connecting the transmitter .....	17	13.6	Mechanical construction .....	49
5.5	Special connection instructions .....	18	13.7	Certificates and approvals .....	53
5.6	Ensuring the degree of protection .....	19	<b>14</b>	<b>Operating menu and parameter description</b> .....	<b>55</b>
5.7	Post-connection check .....	19	14.1	Menu: Diagnostics .....	59
<b>6</b>	<b>Operation options</b> .....	<b>20</b>	14.2	Menu: Application .....	65
6.1	Overview of operation options .....	20	14.3	Menu: System .....	75
6.2	Structure and function of the operating menu .....	23	<b>Index</b> .....	<b>91</b>	
6.3	Access to the operating menu via the PC operating tool .....	25			
6.4	Access to the operating menu via the Wireless Field Device Configurator App .....	26			
<b>7</b>	<b>System integration</b> .....	<b>27</b>			
7.1	Overview of device description files .....	27			
7.2	Measured variables via HART protocol .....	27			
7.3	Supported HART commands .....	27			

# 1 About this document

## 1.1 Document function

These Operating Instructions contain all the information required in the various life cycle phases of the device: from product identification, incoming acceptance and storage, to installation, connection, operation and commissioning, through to troubleshooting, maintenance and disposal.

## 1.2 Safety instructions

When the device is used in hazardous areas, compliance with national regulations is mandatory. Separate Ex-specific documentation is provided for measuring systems that are used in hazardous areas. This documentation is an integral part of these Operating Instructions. The installation specifications, connection data and safety instructions contained therein must be strictly observed. Make sure that you use the right Ex-specific documentation for the right device with approval for use in hazardous areas.

## 1.3 Symbols used

### 1.3.1 Safety symbols

#### DANGER

This symbol alerts you to a dangerous situation. Failure to avoid this situation will result in serious or fatal injury.

#### WARNING

This symbol alerts you to a potentially dangerous situation. Failure to avoid this situation can result in serious or fatal injury.





#### CAUTION

This symbol alerts you to a potentially dangerous situation. Failure to avoid this situation can result in minor or medium injury.













#### NOTICE

This symbol alerts you to a potentially harmful situation. Failure to avoid this situation can result in damage to the product or something in its vicinity.

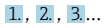

### 1.3.2 Electrical symbols

Symbol	Meaning
	Direct current
	Alternating current
	Direct current and alternating current
	<b>Ground connection</b> A grounded terminal which, as far as the operator is concerned, is grounded via a grounding system.
	<b>Potential equalization connection (PE: protective earth)</b> Ground terminals that must be connected to ground prior to establishing any other connections.  The ground terminals are located on the interior and exterior of the device: <ul style="list-style-type: none"> <li>▪ Interior ground terminal: potential equalization is connected to the supply network.</li> <li>▪ Exterior ground terminal: device is connected to the plant grounding system.</li> </ul>



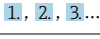

### 1.3.3 Symbols for certain types of information

Symbol	Meaning
	<b>Permitted</b> Procedures, processes or actions that are permitted.
	<b>Preferred</b> Procedures, processes or actions that are preferred.
	<b>Forbidden</b> Procedures, processes or actions that are forbidden.
	<b>Tip</b> Indicates additional information.
	Reference to documentation
	Reference to page
	Reference to graphic
	Notice or individual step to be observed
	Series of steps
	Result of a step
	Help in the event of a problem
	Visual inspection

### 1.3.4 Symbols in graphics

Symbol	Meaning	Symbol	Meaning
1, 2, 3,...	Item numbers		Series of steps
A, B, C, ...	Views	A-A, B-B, C-C, ...	Sections
	Hazardous area		Safe area (non-hazardous area)

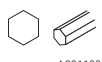
## 1.4 Tool symbols

Symbol	Meaning
 A0011220	Flat-blade screwdriver
 A0011219	Phillips head screwdriver
 A0011221	Allen key
 A0011222	Open-ended wrench
 A0013442	Torx screwdriver

## 1.5 Registered trademarks

### Bluetooth®

The *Bluetooth*® word mark and logos are registered trademarks owned by the Bluetooth SIG, Inc. and any use of such marks by Endress+Hauser is under license. Other trademarks and trade names are those of their respective owners.

### HART®

Registered trademark of the FieldComm Group, Austin, Texas, USA

## 2 Basic safety instructions

### 2.1 Requirements of the personnel

The personnel responsible for installation, commissioning, diagnostics and maintenance must fulfil the following requirements:

- ▶ Trained, qualified specialists: must have a relevant qualification for this specific function and task
- ▶ They must be authorized by the plant operator.
- ▶ They must be familiar with national regulations.
- ▶ Before beginning work, the specialist staff must have read and understood the instructions in the manuals and supplementary documentation as well as in the certificates (depending on the application).
- ▶ They must follow instructions and comply with general policies.

The operating personnel must fulfil the following requirements:

- ▶ They must be instructed and authorized according to the requirements of the task by the plant operator.
- ▶ They must follow the instructions in these Operating Instructions.

### 2.2 Intended use

The device is a universal and user-configurable temperature transmitter with one sensor input for resistance thermometers (RTD), thermocouples (TC), resistance and voltage transmitters. The head transmitter version of the device is intended for mounting in a terminal head (flat face) as per DIN EN 50446. It is also possible to mount the device on a DIN rail using the optional DIN rail clip. The device is also optionally available in a version suitable for DIN rail mounting as per IEC 60715 (TH35).

If the device is used in a manner not specified by the manufacturer, the protection provided by the device may be impaired.

The manufacturer is not liable for damage caused by improper or non-intended use.

### 2.3 Workplace safety

When working on and with the device:

- ▶ Wear the required personal protective equipment as per national regulations.

### 2.4 Operational safety

- ▶ Operate the device only if it is in proper technical condition, free from errors and faults.
- ▶ The operator is responsible for ensuring that the device is in good working order.

### Hazardous area

To eliminate a danger for persons or for the facility when the device is used in the hazardous area (e.g. explosion protection or safety instrumented system):

- ▶ Based on the technical data on the nameplate, check whether the ordered device is permitted for the intended use in the hazardous area. The nameplate can be found on the side of the transmitter housing.
- ▶ Observe the specifications in the separate supplementary documentation included as an integral part of these instructions.

### Electromagnetic compatibility

The measuring system complies with the general safety requirements as per EN 61010-1, the EMC requirements as per the IEC/EN 61326 series and the NAMUR recommendations NE 21.

#### NOTICE

- ▶ The device must be powered only by a power unit that operates using a limited-energy circuit in accordance with UL/EN/IEC 61010-1, Section 9.4 and the requirements in Table 18.

## 2.5 Product safety

This measuring device is designed in accordance with good engineering practice to meet state-of-the-art safety requirements, has been tested, and left the factory in a condition in which it is safe to operate.

It meets general safety standards and legal requirements. It also complies with the EU directives listed in the device-specific EU Declaration of Conformity. The manufacturer confirms this by affixing the CE mark to the device.

## 2.6 IT security

The manufacturer warranty is valid only if the product is installed and used as described in the Operating Instructions. The product is equipped with security mechanisms to protect it against any inadvertent changes to the settings.

IT security measures, which provide additional protection for the product and associated data transfer, must be implemented by the operators themselves in line with their security standards.

# 3 Incoming acceptance and product identification

## 3.1 Incoming acceptance

On receipt of the delivery:

1. Check the packaging for damage.
  - ↳ Report all damage immediately to the manufacturer.  
Do not install damaged components.
2. Check the scope of delivery using the delivery note.
3. Compare the data on the nameplate with the order specifications on the delivery note.

4. Check the technical documentation and all other necessary documents, e.g. certificates, to ensure they are complete.

 If one of the conditions is not satisfied, contact the manufacturer.

## 3.2 Product identification

### 3.2.1 Nameplate

#### Do you have the correct device?

The nameplate provides you with the following information on the device:

- Manufacturer identification, device designation
- Serial number
- Tag name (TAG) (optional)
- Technical values, e.g. supply voltage, current consumption, ambient temperature, communication-specific data (optional)
- Degree of protection
- Approvals with symbols

► Compare the information on the nameplate with the order.

### 3.2.2 Name and address of manufacturer

Name of manufacturer:	Endress+Hauser Wetzer GmbH + Co. KG
Address of manufacturer:	Obere Wank 1, D-87484 Nesselwang

## 3.3 Storage and transport

Storage temperature

Head transmitter	-50 to +100 °C (-58 to +212 °F)
DIN rail transmitter	-50 to +100 °C (-58 to +212 °F)

Maximum relative humidity: < 95 % as per IEC 60068-2-30

 Pack the device for storage and transportation in such a way that it is reliably protected against impact and external influences. The original packaging provides the best protection.

Avoid the following environmental influences during storage:

- Direct sunlight
- Vibration
- Aggressive media



## 4 Installation

### 4.1 Installation requirements

#### 4.1.1 Dimensions

The dimensions of the device are provided in the "Technical data" section .

#### 4.1.2 Installation point

- Head transmitter:
  - in the terminal head, flat face, as per DIN EN 50446, direct installation on insert with cable entry (middle hole 7 mm)
  - in the field housing, separately from the process
- DIN rail transmitter:  
Designed for mounting on a DIN rail (IEC 60715 TH35).

 It is also possible to mount the head transmitter on a DIN rail as per IEC 60715 using the DIN rail clip accessory.

Information about the conditions (such as the ambient temperature, degree of protection, climate class etc.) that must be present at the installation point so that the device can be mounted correctly is provided in the "Technical data" section →  48.

For use in hazardous areas, the limit values specified on the certificates and approvals must be observed (see Ex Safety Instructions).

#### NOTICE

**In cases where a DIN rail transmitter is installed and simultaneous thermocouple or mV measurements are performed, increased measurement errors may occur depending on the installation situation and ambient conditions.**

- ▶ If the DIN rail transmitter is mounted in series between other DIN rail devices (reference operating conditions: 24 V, 12 mA), deviations of up to + 2.9 °C may occur.

### 4.2 Installing the device

A Phillips head screwdriver is required to mount the head transmitter.

- Maximum torque for securing screws = 1 Nm (¾ foot-pound), screwdriver: Pozidriv Z2
- Maximum torque for screw terminals = 0.35 Nm (¼ foot-pound), screwdriver: Pozidriv Z1

### 4.2.1 Mounting the head transmitter

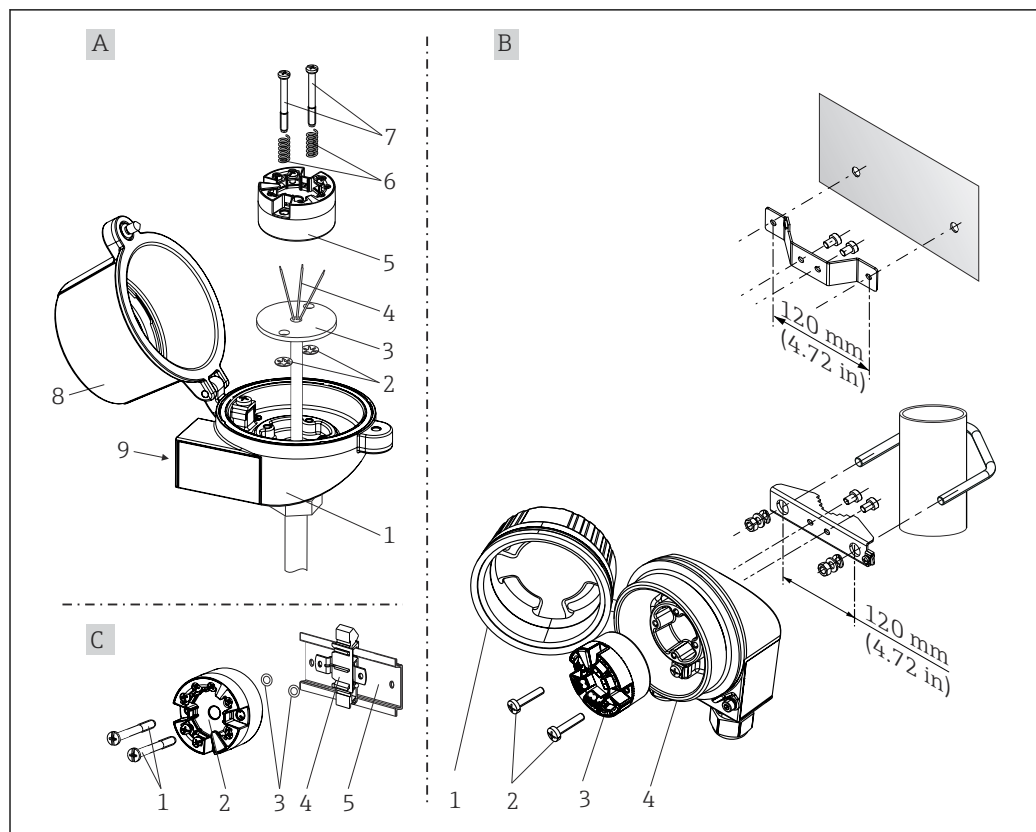

1 Head transmitter mounting (three versions)

A	Mounting in a terminal head (terminal head flat face as per DIN 43729)
1	Terminal head
2	Retaining rings
3	Insert
4	Connection wires
5	Head transmitter
6	Mounting springs
7	Mounting screws
8	Terminal head cover
9	Cable entry

Procedure for mounting in a terminal head, pos. A:

1. Open the terminal head cover (8) on the terminal head.
2. Guide the connection wires (4) of the insert (3) through the center hole in the head transmitter (5).
3. Fit the mounting springs (6) on the mounting screws (7).
4. Guide the mounting screws (7) through the side boreholes of the head transmitter and the insert (3). Then fix both mounting screws with the snap rings (2).
5. Then tighten the head transmitter (5) along with the insert (3) in the terminal head.
6. After wiring, close the terminal head cover (8) tightly again. → 15

<b>B</b>	<b>Mounting in a field housing</b>
1	Field housing cover
2	Mounting screws
3	Head transmitter
4	Field housing

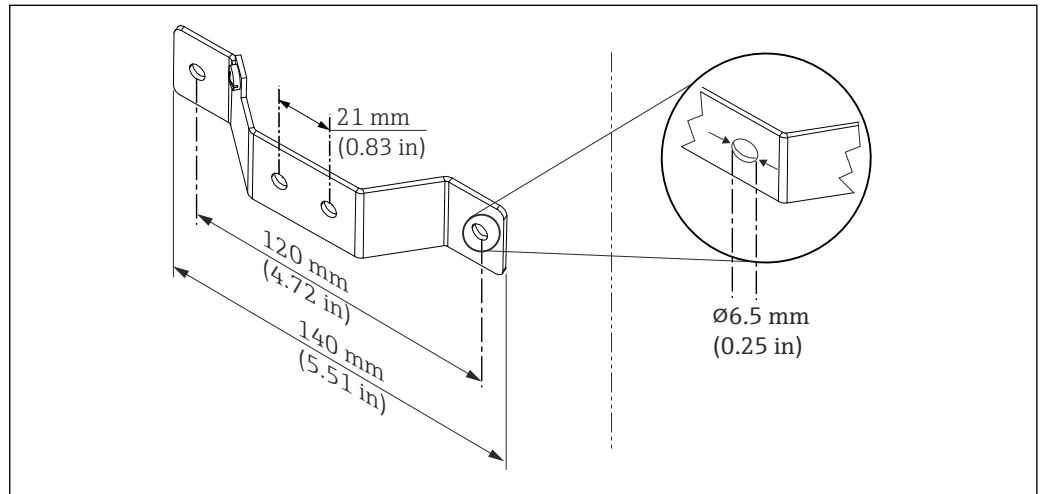

 2 Dimensions of angle bracket for wall mount (complete wall mounting set available as accessory)

Procedure for mounting in a field housing, pos. B:

1. Open the cover (1) of the field housing (4).
2. Guide the mounting screws (2) through the lateral bores in the head transmitter (3).
3. Screw the head transmitter to the field housing.
4. After wiring, close the field housing cover (1) again. →  15

<b>C</b>	<b>Mounting on DIN rail (DIN rail as per IEC 60715)</b>
1	Mounting screws
2	Head transmitter
3	Retaining rings
4	DIN rail clip
5	DIN rail

Procedure for mounting on a DIN rail, pos. C:

1. Press the DIN rail clip (4) onto the DIN rail (5) until it engages with a click.
2. Guide the mounting screws (1) through the lateral bores in the head transmitter (2). Then fix both mounting screws with the snap rings (3).
3. Screw the head transmitter (2) onto the DIN rail clip (4).

### Mounting for North America

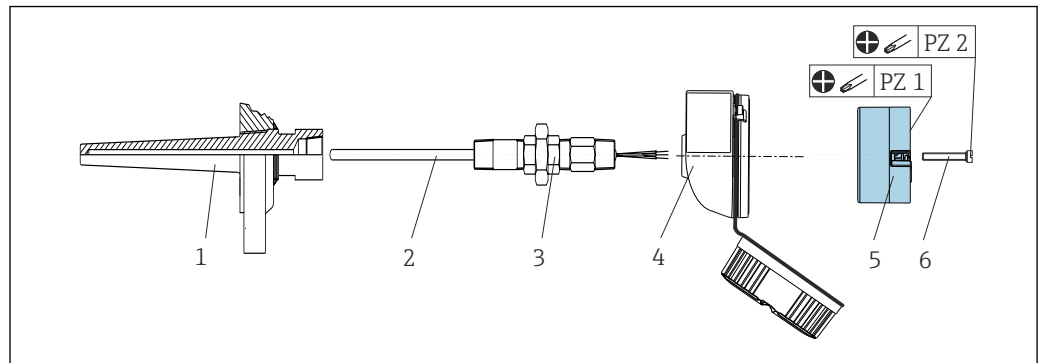

A0008520

#### 3 Head transmitter mounting

- 1 Thermowell
- 2 Insert
- 3 Adapter, coupling
- 4 Terminal head
- 5 Head transmitter
- 6 Mounting screws

Thermometer design with thermocouples or RTD sensors and head transmitter:

1. Fit the thermowell (1) on the process pipe or the container wall. Secure the thermowell according to the instructions before the process pressure is applied.
2. Fit the necessary neck tube nipples and adapter (3) on the thermowell.
3. Make sure sealing rings are installed if such rings are needed for harsh environmental conditions or special regulations.
4. Guide the mounting screws (6) through the lateral bores of the head transmitter (5).
5. Position the head transmitter (5) in the terminal head (4) in such a way that the bus cable (terminals 1 and 2) point to the cable entry.
6. Using a screwdriver, screw down the head transmitter (5) in the terminal head (4).
7. Guide the connection wires of the insert (3) through the lower cable entry of the terminal head (4) and through the middle hole in the head transmitter (5). Wire the connection wires up to the transmitter. → 16
8. Screw the terminal head (4), with the integrated and wired head transmitter, onto the ready-mounted nipple and adapter (3).

#### NOTICE

**The terminal head cover must be secured properly to meet the requirements for explosion protection.**

- ▶ After wiring, securely screw the terminal head cover back on.

### Mounting the display on the head transmitter

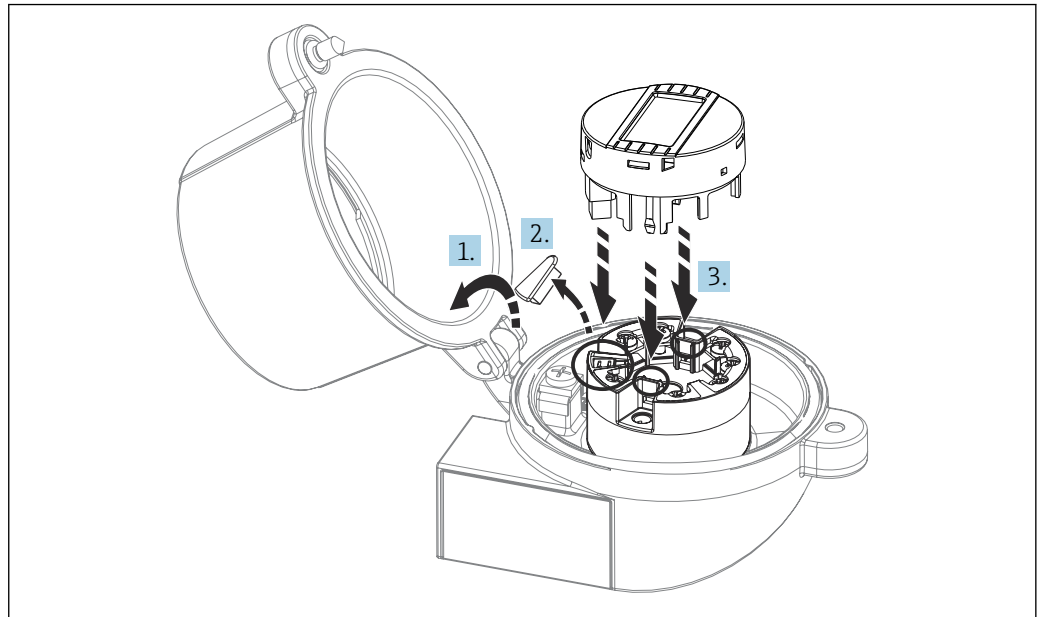

A0009852

#### 4 Mounting the display

1. Loosen the screw on the terminal head cover. Flip back the terminal head cover.
2. Remove the cover of the display connection area.
3. Fit the display module onto the mounted and wired head transmitter. The fastening pins must click securely into place on the head transmitter. After mounting, securely tighten the terminal head cover.

**i** The display can be used only with the appropriate terminal heads - cover with viewing window.

### 4.2.2 Mounting the DIN rail transmitter

#### NOTICE

#### Wrong orientation

Measurement deviates from the maximum measurement accuracy when a thermocouple is connected and the internal reference junction is used.

- Mount the device vertically and ensure it is correctly oriented.

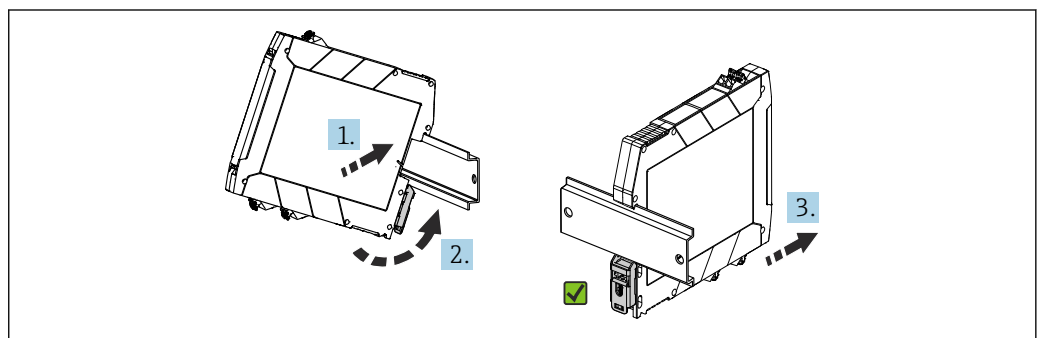

A0039678

#### 5 Mounting the DIN rail transmitter

1. Position the top DIN rail groove at the top end of the DIN rail.
2. Slide the bottom of the device over the bottom end of the DIN rail until you can hear the lower DIN rail clip click into place on the DIN rail.

3. Pull gently on the device to check if it is correctly mounted on the DIN rail. If it doesn't move, the DIN rail transmitter is correctly mounted.

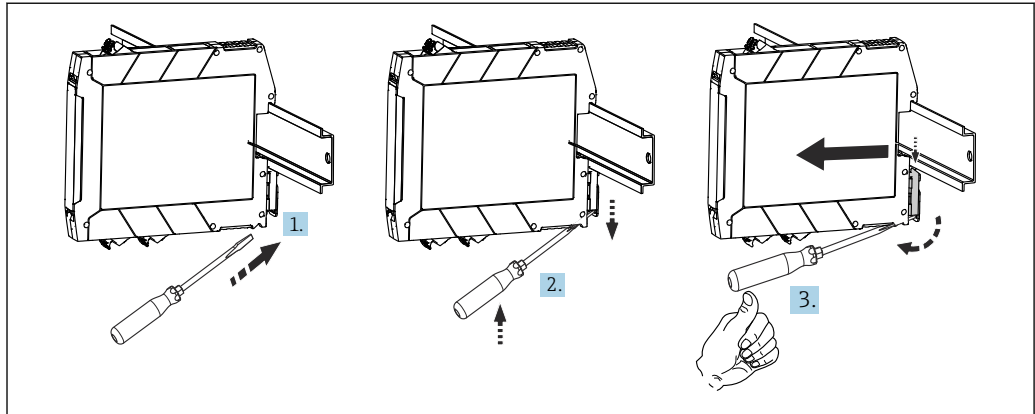

6 Dismantling the DIN rail transmitter

A0039696

Dismantling the DIN rail transmitter:

1. Insert a screwdriver into the tab of the DIN rail clip.
2. Use the screwdriver to pull down on the DIN rail clip as shown in the diagram.
3. Hold down the screwdriver to remove the device from the DIN rail.

### 4.3 Post-installation check

After installing the device, always perform the following checks:

Device condition and specifications	Notes
Is the device undamaged (visual inspection)?	-
Do the ambient conditions match the device specification (e.g. ambient temperature, measuring range, etc.)?	See the 'Technical data' section

## 5 Electrical connection

### ⚠ CAUTION

- ▶ Switch off the power supply before installing or connecting the device. Failure to observe this may result in the destruction of parts of the electronics.
- ▶ Do not occupy the display connection. An incorrect connection can destroy the electronics.

### NOTICE



**Do not overtighten the screw terminals, as this could damage the transmitter.**

- ▶ Maximum torque = 0.35 Nm ( $\frac{1}{4}$  lbf ft), screwdriver: Pozidriv PZ1.

### 5.1 Connection requirements

A Phillips head screwdriver is required to wire the head transmitter with screw terminals. A flat-blade screwdriver must be used for the DIN rail transmitter version with screw terminals. The push-in terminal version can be wired without any tools.

Proceed as follows to wire a head transmitter mounted in the terminal head or field housing:

1. Open the cable gland and the housing cover on the terminal head or the field housing.
2. Feed the cables through the opening in the cable gland.
3. Connect the cables as shown in →  16. If the head transmitter is fitted with push-in terminals, pay particular attention to the information in the "Connecting to push-in terminals" section. →  17
4. Tighten the cable gland again and close the housing cover.

In order to avoid connection errors always follow the instructions in the post-connection check section before commissioning!

## 5.2 Quick wiring guide

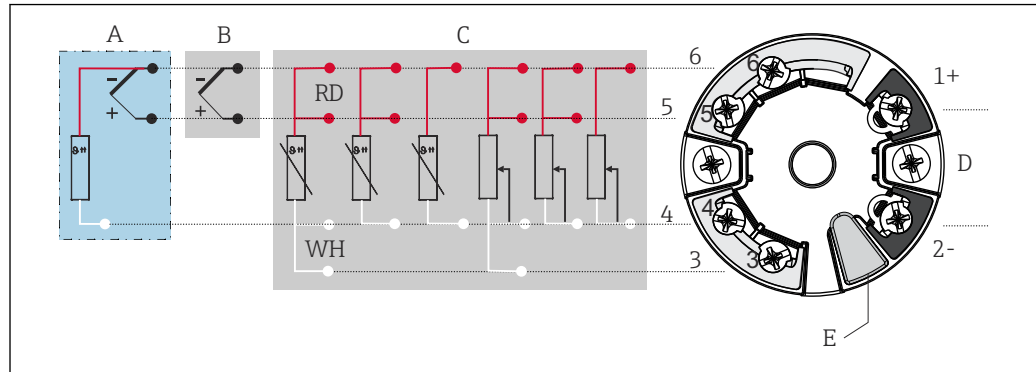

A0047635

**7** Assignment of terminal connections for head transmitter

- A Sensor input, TC and mV, external reference junction (CJ), Pt100
- B Sensor input, TC and mV, internal reference junction (CJ)
- C Sensor input, RTD and  $\Omega$ , 4-, 3- and 2-wire
- D Bus connection and power supply 4 to 20 mA
- E Display connection and CDI interface

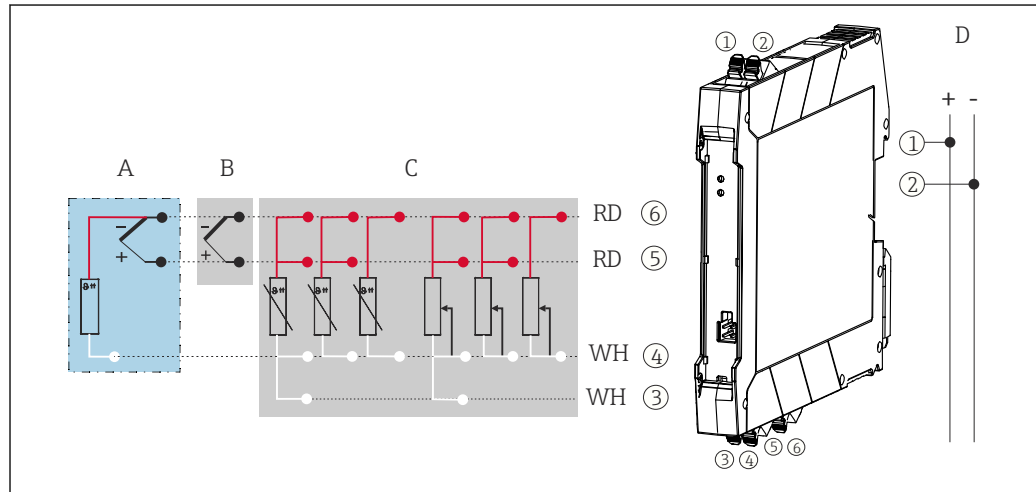

A0047638

**8** Assignment of terminal connections for DIN rail transmitter

- A Sensor input, TC and mV, external reference junction (CJ), Pt100
- B Sensor input, TC and mV, internal reference junction (CJ)
- C Sensor input, RTD and  $\Omega$ , 4-, 3- and 2-wire
- D Bus connection and power supply 4 to 20 mA

An unshielded installation cable is sufficient for using the analog signal. In case of increased EMC influences, the use of shielded cables is recommended. For the DIN rail transmitter, a shielded cable must be used for sensor cable lengths of 30 m (98.4 ft) or more.

A shielded cable is recommended for HART communication. Observe grounding concept of the plant. A minimum load of 250  $\Omega$  is required in the signal circuit in order to operate the HART transmitter via the HART protocol (terminals 1 and 2).

For a thermocouple measurement (TC), a Pt100 2-wire sensor can be connected to measure the reference junction temperature. This is connected to terminals 4 and 6.

### NOTICE

- ▶  ESD – Electrostatic discharge. Protect the terminals from electrostatic discharge. Failure to observe this may result in the destruction or malfunction of parts of the electronics.



## 5.3 Connecting the sensor

Terminal assignment of the sensor connections →  16.

### 5.3.1 Connecting to push-in terminals

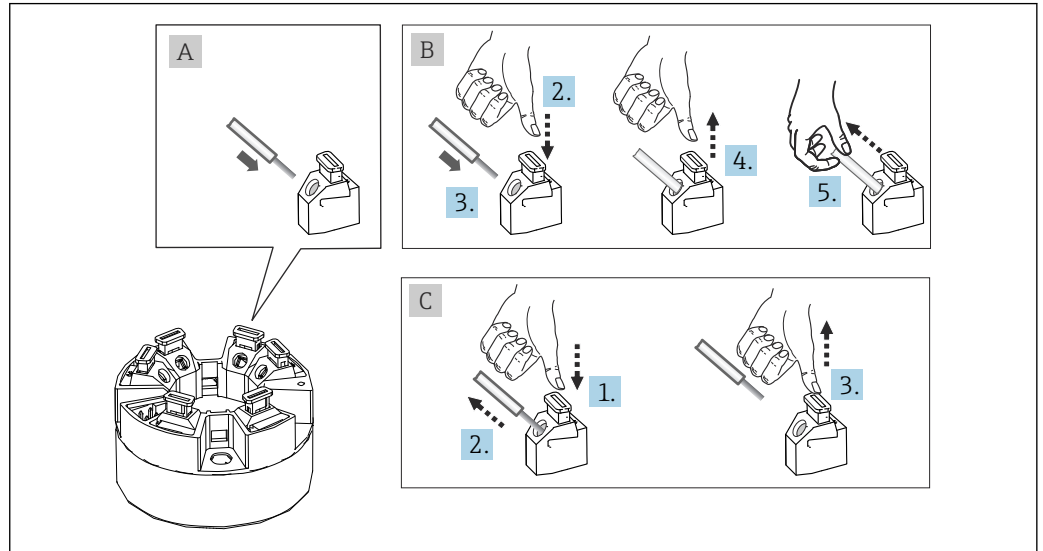

 9 Push-in terminal connection, using the example of a head transmitter

#### Pos. A, solid wire, fine-strand wire with ferrule:

1. Strip wire end. Minimum stripping length 10 mm (0.39 in).
2. Insert the wire end into the terminal.
3. Pull the wire gently to ensure it is connected correctly. Repeat starting from step 1 if necessary.

#### Fig. B, fine-strand wire without ferrule:

1. Strip wire end. Minimum stripping length 10 mm (0.39 in).
2. Press down on the lever opener.
3. Insert the wire end into the terminal.
4. Release lever opener.
5. Pull the wire gently to ensure it is connected correctly. Repeat starting from step 1 if necessary.

#### Pos. C, releasing the connection:

1. Press down on the lever opener.
2. Remove the wire from the terminal.
3. Release lever opener.

## 5.4 Connecting the transmitter

Also observe the general procedure on →  15.

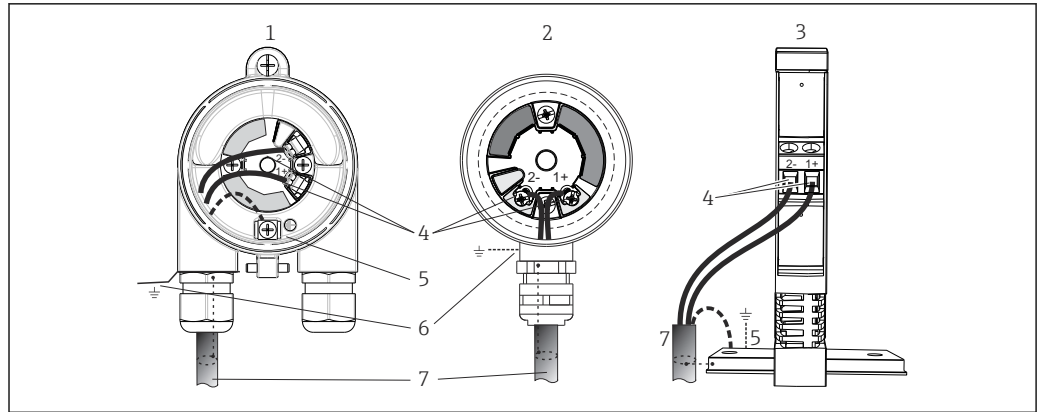

A0039698

**10** Connecting the signal cables and power supply

- 1 Head transmitter installed in field housing
- 2 Head transmitter installed in terminal head
- 3 DIN rail transmitter mounted on DIN rail
- 4 Terminals for power supply
- 5 Internal ground connection
- 6 External ground connection
- 7 Shielded signal cable

- i**
- The terminals for (1+ and 2-) are protected against reverse polarity.
  - Conductor cross-section:
    - max. 2.5 mm<sup>2</sup> (13 AWG) for screw terminals
    - max. 1.5 mm<sup>2</sup> (15 AWG) for push-in terminals Min. stripping length of wire 10 mm (0.39 in)

## 5.5 Special connection instructions

### Shielding and grounding

The specifications of the FieldComm Group must be observed when installing the HART transmitter.

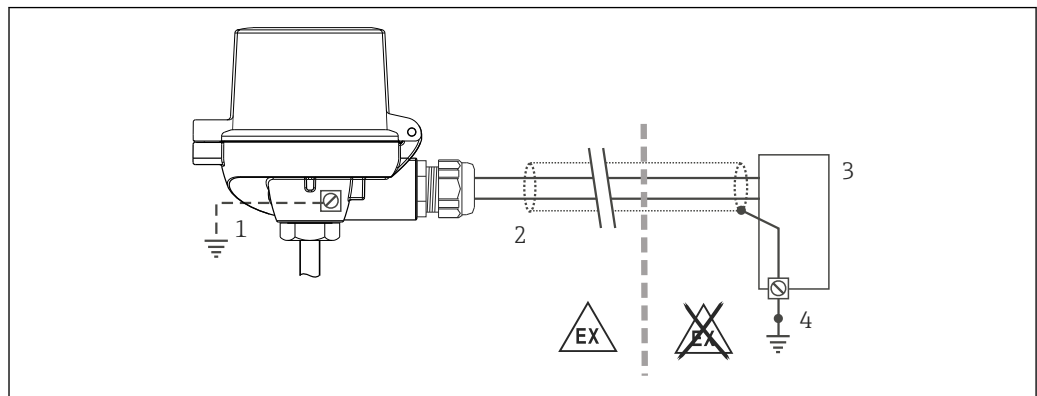





A0014463

**11** Shielding and grounding the signal cable at one end with HART communication

- 1 Optional grounding of the field device, isolated from cable shielding
- 2 Grounding of the cable shield at one end
- 3 Supply unit
- 4 Grounding point for HART communication cable shield

## 5.6 Ensuring the degree of protection

The device meets the requirements for IP67 protection. Compliance with the following points is mandatory following installation in the field or servicing in order to ensure that IP67 protection is maintained:

- The transmitter must be mounted in a terminal head with the appropriate degree of protection.
- The housing seals must be clean and undamaged when inserted into the sealing groove. The seals must be dried, cleaned or replaced if necessary.
- The connecting cables used must have the specified external diameter (e.g. M20x1.5, cable diameter 8 to 12 mm).
- Firmly tighten the cable gland. →  12,  19
- The cables must loop down before they enter the cable glands ("water trap"). This means that any moisture that may form cannot enter the gland. Install the device in such a way that the cable glands are not facing upwards. →  12,  19
- Replace unused cable glands with dummy plugs.
- Do not remove the grommet from the cable gland.

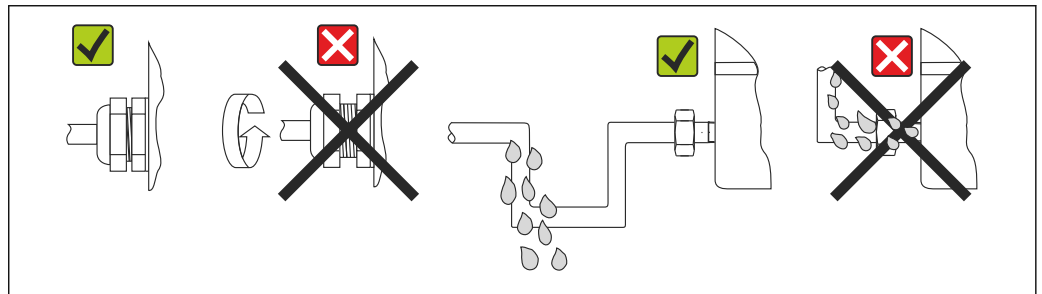

A0024523

 12 Connection tips to retain IP67 protection

## 5.7 Post-connection check

Device condition and specifications	Notes
Is the device or cable undamaged (visual check)?	--
Electrical connection	Notes
Does the supply voltage match the specifications on the nameplate?	<ul style="list-style-type: none"> <li>■ Head transmitter: <math>U = 10</math> to <math>36 V_{DC}</math></li> <li>■ DIN rail transmitter: <math>U = 11</math> to <math>36 V_{DC}</math></li> <li>■ Other values apply in the hazardous area; see the corresponding Ex Safety Instructions.</li> </ul>
Are the mounted cables relieved of tension?	--
Are the power supply and signal cables connected correctly?	→  16
Are all the screw terminals firmly tightened and have the push-in terminal connections been checked?	--
Are all the cable entries installed, tightened and leak-tight?	--
Are all housing covers installed and securely tightened?	--

## 6 Operation options

### 6.1 Overview of operation options

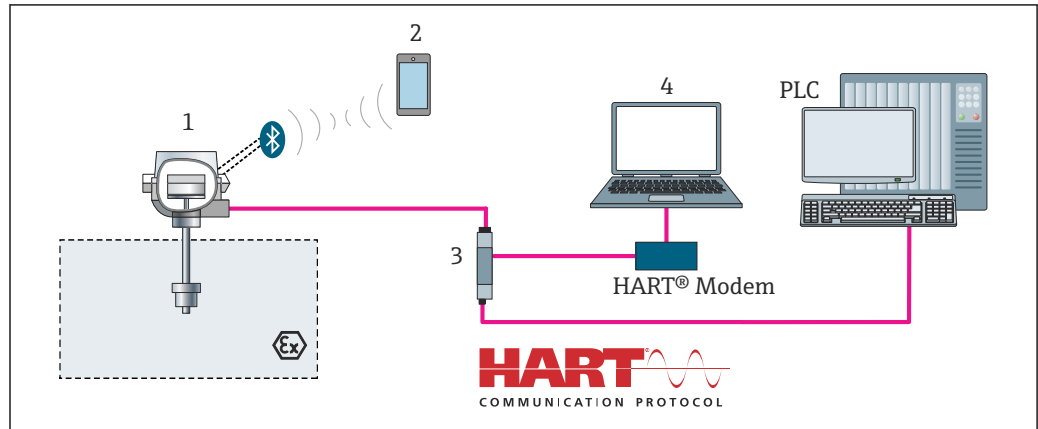

A0051229

13 Operation options for the transmitter via HART communication

- 1 Transmitter
- 2 Operation via Bluetooth
- 3 Active barrier
- 4 Configuration software

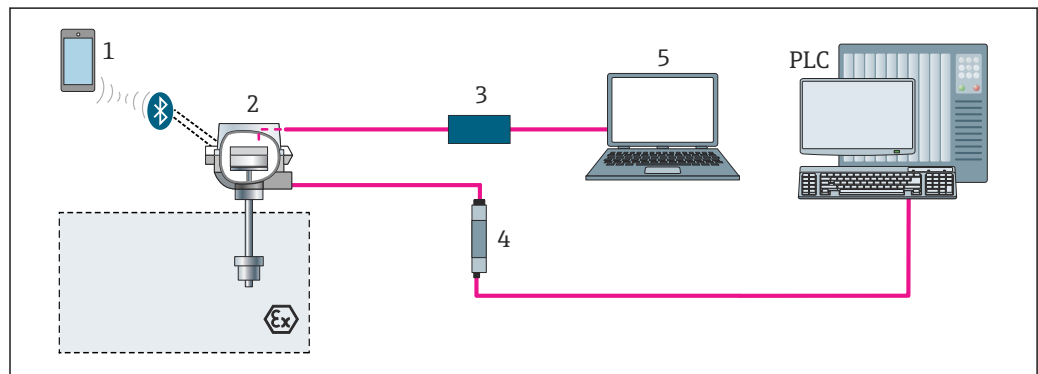

A0051230

14 Operation options for the transmitter via the CDI interface

- 1 Operation via Bluetooth
- 2 Transmitter
- 3 Configuration kit
- 4 Active barrier
- 5 Configuration software

**i** The transmitter's optional Bluetooth interface is only active if a display unit is not attached or the CDI interface is not used for device configuration.

### 6.1.1 Measured value display and operating elements

Option: display with transmitter

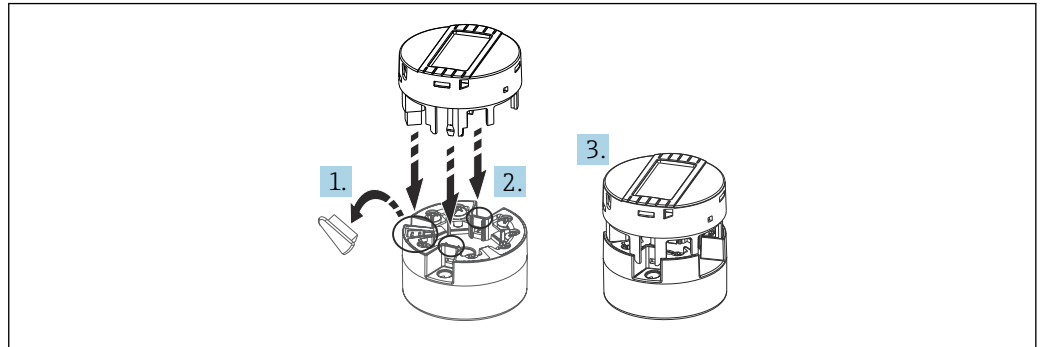

A0010227

15 Attach the display to the transmitter

#### Display elements

Head transmitter

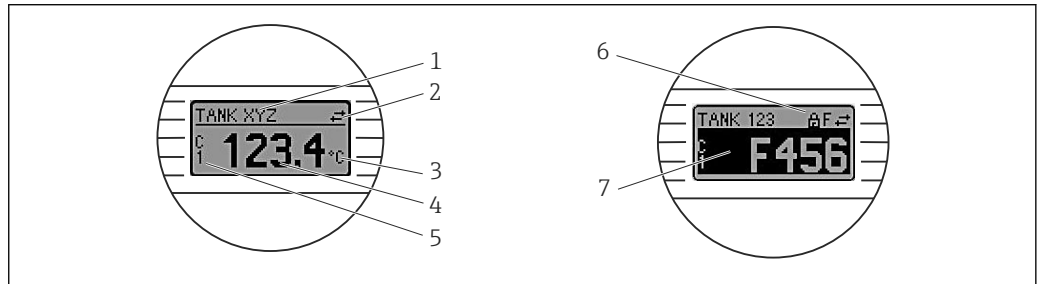

A0008549

16 Optional LC display for head transmitter

Item no.	Function	Description
1	Displays the TAG	TAG, 32 characters long.
2	'Communication' symbol	The communication symbol appears when read and write-accessing via the fieldbus protocol.
3	Unit display	Unit display for the measured value displayed.
4	Measured value display	Displays the current measured value.
5	Value/channel display DT, PV, I, %	e.g. PV for a measured value from channel 1 or DT for the device temperature
6	'Configuration locked' symbol	The 'configuration locked' symbol appears when configuration is locked via the hardware.
7	Status signals	
	Symbols	Meaning
	<b>F</b>	<b>Error message "Failure detected"</b> An operating error has occurred. The measured value is no longer valid. The display alternates between the error message and "- - -" (no valid measured value present), see "Diagnostics events" section → 33. Detailed information on the error messages can be found in the Operating Instructions.
	<b>C</b>	<b>"Service mode"</b> The device is in service mode (e.g. during a simulation).

Item no.	Function	Description
	<b>S</b>	<b>"Out of specification"</b> The device is being operated outside its technical specifications (e.g. during startup or cleaning processes).
	<b>M</b>	<b>"Maintenance required"</b> Maintenance is required. The measured value remains valid. The display alternates between the measured value and the status message.

*DIN rail transmitter*

*Two LEDs on the front indicate the device status.*

Type	Function and characteristic
Status LED (red)	When the device is operating without errors, the device status is displayed. This function can no longer be guaranteed in the event of an error. <ul style="list-style-type: none"> <li>▪ LED off: without diagnostic message</li> <li>▪ LED is lit: diagnostic display, category F</li> <li>▪ LED flashing: diagnostic display of categories C, S or M</li> </ul>
Power LED (green) 'ON'	When the device is operating without errors, the operating status is displayed. This function can no longer be guaranteed in the event of an error. <ul style="list-style-type: none"> <li>▪ LED off: Power failure or insufficient supply voltage</li> <li>▪ LED is lit: Supply voltage is OK (either via CDI or via supply voltage, terminals 1+, 2-)</li> </ul>

**i** The DIN rail transmitter version does not have an interface to the LC display and therefore does not have a local display either.

**Local operation**

You can make various hardware settings using miniature switches (DIP switches) on the rear of the optional display.

**i** Optionally, the display can be ordered with the head transmitter, or as an accessory for subsequent mounting.

**NOTICE**

▶ **ESD** - Electrostatic discharge Protect the terminals from electrostatic discharge. Failure to observe this may result in the destruction or malfunction of parts of the electronics.

	1: Connection to head transmitter
	2: DIP switches (1 - 64, SW/HW, ADDR and SIM = simulation mode) have <b>no function</b> for this head transmitter
	3: DIP switch (WRITE LOCK = write protection; DISPL. 180° = switch, turn the display monitor 180°)

A0014562

**17** Hardware settings via DIP switches

Procedure for setting the DIP switch:

1. Open the cover of the terminal head or field housing.
2. Remove the attached display from the head transmitter.

3. Configure the DIP switch on the rear of the display accordingly. In general: switch to ON = function enabled, switch to OFF = function disabled.
4. Fit the display onto the head transmitter in the correct position. The head transmitter accepts the settings within one second.
5. Secure the cover back onto the terminal head or field housing.

*Switching write protection on/off*

Write protection is switched on and off via a DIP switch on the rear of the optional attachable display. When write protection is active, parameters cannot be modified. A lock symbol on the display indicates that write protection is on. Write protection prevents any write access to the parameters. Write protection remains active even when the display is removed. To deactivate write protection, the display must be attached to the transmitter with the DIP switch switched off (WRITE LOCK = OFF). The transmitter adopts the setting during operation and does not need to be restarted.

*Turning the display*

The display can be rotated 180° using the "DISPL. 180°" DIP switch.

## 6.2 Structure and function of the operating menu

### 6.2.1 Structure of the operating menu

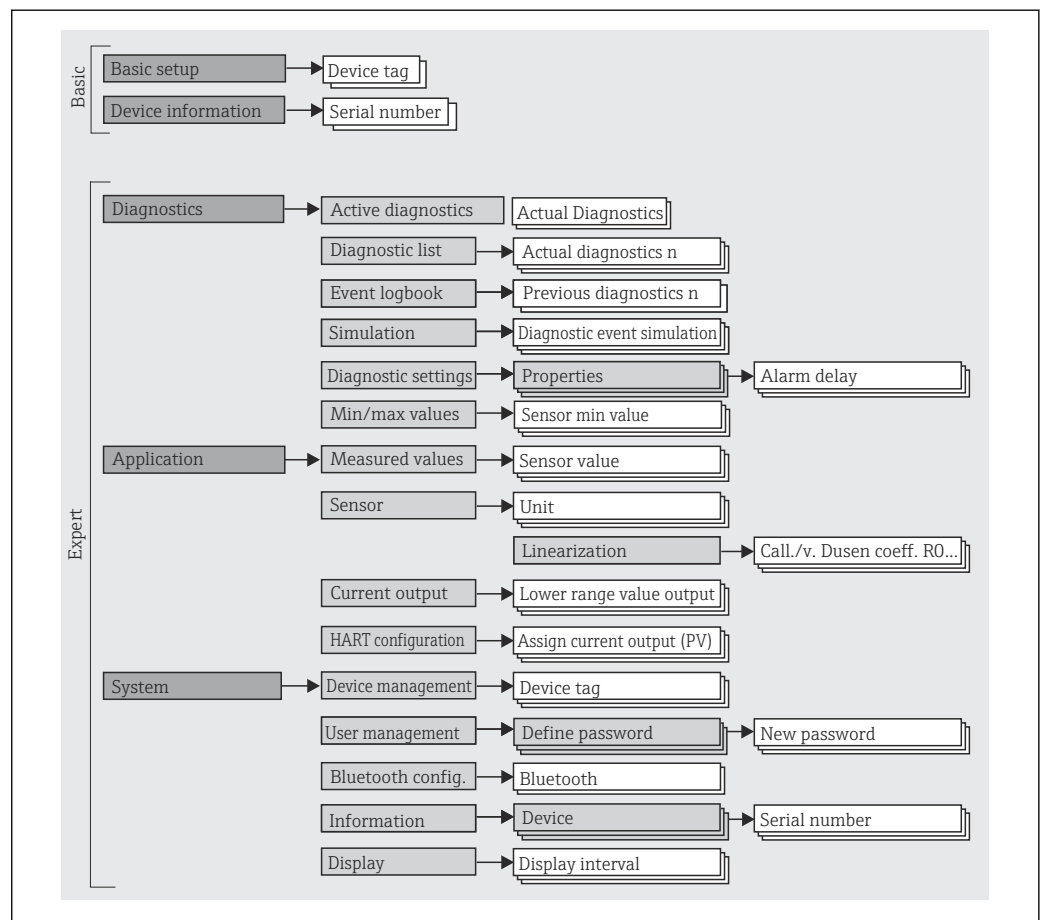

A0051676

## User roles

The role-based access concept consists of two hierarchical levels for the user and presents the various user roles with defined read/write authorizations derived from the NAMUR shell model.

### ■ Operator

The plant operator can only change settings that do not affect the application - and particularly the measuring path - and simple, application-specific functions that are used during operation. The operator is able to read all the parameters, however.

### ■ Maintenance

The **Maintenance** user role refers to configuration situations: commissioning and process adaptations as well as troubleshooting. It allows the user to configure and modify all available parameters. In contrast to the **Operator** user role, in the Maintenance role the user has read and write access to all the parameters.

### ■ Changing the user role

A user role - and therefore existing read and write authorization - is changed by selecting the desired user role (already pre-selected depending on the operating tool) and entering the correct password when subsequently prompted. When a user logs out, system access always returns to the lowest level in the hierarchy. A user is logged out either by actively selecting the logout function when operating the device or is logged out automatically if the device is not operated for a period of over 600 seconds. Irrespective of this, actions that are already in progress (e.g. active upload/download, data logging, etc.) continue to be executed in the background.

### ■ As-delivered state

The **Operator** user role is not enabled when the device is delivered from the factory, i.e. the **Maintenance** role is the lowest level in the hierarchy ex-works. This state makes it possible to commission the device and make other process adaptations without having to enter a password. Afterwards, a password can be assigned for the **Maintenance** user role to protect this configuration. The **Operator** user role is not visible when the device is delivered from the factory.

### ■ Password

The **Maintenance** user role can assign a password in order to restrict access to device functions. This activates the **Operator** user role, which is now the lowest hierarchy level where the user is not asked to enter a password. The password can only be changed or disabled in the **Maintenance** user role. A password can be defined at different points in the operation of the device:

In the menu: System → User management



## Submenus

Menu	Typical tasks	Content/meaning
"Diagnostics"	Troubleshooting: <ul style="list-style-type: none"> <li>▪ Diagnosing and eliminating process errors.</li> <li>▪ Error diagnostics in difficult cases.</li> <li>▪ Interpretation of device error messages and correcting associated errors.</li> </ul>	Contains all parameters for detecting and analyzing errors: <ul style="list-style-type: none"> <li>▪ <b>Diagnostic list</b> Contains up to 3 error messages currently pending</li> <li>▪ <b>Event logbook</b> Contains the last 10 error messages</li> <li>▪ <b>"Simulation" submenu</b> Used to simulate measured values, output values or diagnostic messages</li> <li>▪ <b>"Diagnostic settings" submenu</b> Contains all the parameters for configuring error events</li> <li>▪ <b>"Min/max values" submenu</b> Contains the minimum/maximum indicator and the reset option</li> </ul>
"Application"	Commissioning: <ul style="list-style-type: none"> <li>▪ Configuration of the measurement.</li> <li>▪ Configuration of data processing (scaling, linearization, etc.).</li> <li>▪ Configuration of the analog measured value output.</li> </ul> Tasks during operation: Reading measured values.	Contains all parameters for commissioning: <ul style="list-style-type: none"> <li>▪ <b>"Measured values" submenu</b> Contains all the current measured values</li> <li>▪ <b>"Sensor" submenu</b> Contains all the parameters for configuring the measurement</li> <li>▪ <b>"Output" submenu</b> Contains all the parameters for configuring the analog current output</li> <li>▪ <b>"HART configuration" submenu</b> Contains the settings and the most important parameters for HART communication</li> </ul>
"System"	Tasks that require detailed knowledge of the system administration of the device: <ul style="list-style-type: none"> <li>▪ Optimum adaptation of the measurement for system integration.</li> <li>▪ Detailed configuration of the communication interface.</li> <li>▪ User and access administration, password control</li> <li>▪ Information for device identification, HART infos and display configuration</li> </ul>	Contains all the higher-level device parameters that are assigned for system, device and user management, including Bluetooth configuration. <ul style="list-style-type: none"> <li>▪ <b>"Device management" submenu</b> Contains parameters for general device management</li> <li>▪ <b>"Bluetooth configuration" submenu (option)</b> Contains the function for enabling/disabling the Bluetooth interface</li> <li>▪ <b>"Device and user management" submenus</b> Parameters for access authorization, password assignment, etc.</li> <li>▪ <b>"Information" submenu</b> Contains all the parameters for the unique identification of the device</li> <li>▪ <b>"Display" submenu</b> Configuration of the display</li> </ul>

## 6.3 Access to the operating menu via the PC operating tool

### 6.3.1 Field Device Configurator (FDC) Tool

#### Range of functions



A0051704

The FDC Tool is a configuration tool that is available free of charge. The devices can be connected directly via a modem (point-to-point). DeviceCare is fast, easy and intuitive to use. It can run on a PC, laptop or tablet with a Windows operating system. For more information, please contact your supplier.

## 6.4 Access to the operating menu via the Wireless Field Device Configurator App

 <p>A0051704</p>	<p>The device, which is equipped with optional Bluetooth communication electronics, can be operated and configured via the Wireless Field Device Configurator (FDC) app. The connection is established via the Bluetooth interface.</p> <p>Prerequisite: A smartphone or tablet with the FDC app installed.</p> <p><i>Supported functions</i></p> <ul style="list-style-type: none"> <li>▪ Device selection in Live List and access to the device (login)</li> <li>▪ Configuration of the device</li> <li>▪ Access to measured values, device status and diagnostic information</li> </ul>
---	--

The FDC app is available for free download for Android devices (Google Playstore) and iOS devices (iTunes Apple Shop): *Field Device Configurator*

Directly to the app with the QR code:

			
---	---	--	---

A0051703

Download the FDC app:

1. Install and start the FDC app.
  - ↳ A Live List shows all the devices available.
2. Select the device from the Live List.
  - ↳ The Login dialog box opens.

Logging in:

3. Enter the user name: **admin**
4. Enter the initial password: serial number of the device.
5. Confirm your entry.
  - ↳ The device information opens.

 Navigate through the various items of information about the device: swipe the screen to the side.

- The range under reference conditions is:
  - 10 m (33 ft) when installed in the terminal head or field housing with a display window or DIN rail transmitter
  - 5 m (16.4 ft) when installed in the terminal head or field housing
- Incorrect operation by unauthorized persons is prevented by means of encrypted communication and password encryption
- The Bluetooth interface can be deactivated.

 The transmitter's optional Bluetooth interface is only active if a display unit is not attached or the CDI interface is not used for device configuration.

## 7 System integration

### 7.1 Overview of device description files

*Version data for the device*

Firmware version	01.01.zz	<ul style="list-style-type: none"> <li>▪ On the title page of the Operating Instructions</li> <li>▪ On the nameplate</li> <li>▪ <b>Firmware version</b> parameter System → Information → Device → Firmware version</li> </ul>
Manufacturer ID	0x11	<p><b>Manufacturer ID</b> parameter System → Information → HART info → Manufacturer ID</p>
Device type code	0x11D0	<p><b>Device type</b> parameter System → Information → HART info → Device type</p>
HART protocol revision	7	---
Device revision	1	<ul style="list-style-type: none"> <li>▪ On the transmitter nameplate</li> <li>▪ <b>Device revision</b> parameter System → Information → HART info → Device revision</li> </ul>

### 7.2 Measured variables via HART protocol

The following measured values are assigned to the device variables at the factory:

Device variable	Measured value
Primary device variable (PV)	Sensor 1
Secondary device variable (SV)	Device temperature
Tertiary device variable (TV)	Sensor 1
Quaternary device variable (QV)	Sensor 1

 It is possible to change the assignment of device variables to process variables in the menu **Expert → Communication → HART output**.

### 7.3 Supported HART commands

 The HART protocol enables the transfer of measuring data and device data between the HART master and the field device for configuration and diagnostics purposes. HART masters such as the handheld terminal or PC-based operating programs need device description files (DD = Device Descriptions, DTM) which are used to access all the information in a HART device. This information is transmitted exclusively via "commands".

There are three different types of command

- **Universal commands:**  
All HART devices support and use universal commands. These are associated with the following functionalities for example:
  - Recognition of HART devices
  - Reading digital measured values
- **Common practice commands:**  
Common practice commands offer functions which are supported and can be executed by many but not all field devices.
- **Device-specific commands:**  
These commands allow access to device-specific functions which are not HART standard. Such commands access individual field device information, among other things.

Command No.	Description
<b>Universal commands</b>	
0, Cmd0	Read unique identifier
1, Cmd001	Read primary variable
2, Cmd002	Read loop current and percent of range
3, Cmd003	Read dynamic variables and loop current
6, Cmd006	Write polling address
7, Cmd007	Read loop configuration
8, Cmd008	Read dynamic variable classifications
9, Cmd009	Read device variables with status
11, Cmd011	Read unique identifier associated with TAG
12, Cmd012	Read message
13, Cmd013	Read TAG, descriptor, date
14, Cmd014	Read primary variable transducer information
15, Cmd015	Read device information
16, Cmd016	Read final assembly number
17, Cmd017	Write message
18, Cmd018	Write TAG, descriptor, date
19, Cmd019	Write final assembly number
20, Cmd020	Read long TAG (32-byte TAG)
21, Cmd021	Read unique identifier associated with long TAG
22, Cmd022	Write long TAG (32-byte TAG)
38, Cmd038	Reset configuration changed flag
48, Cmd048	Read additional device status
<b>Common practice commands</b>	
33, Cmd033	Read device variables
34, Cmd034	Write primary variable damping value
35, Cmd035	Write primary variable range values
40, Cmd040	Enter/Exit fixed current mode
42, Cmd042	Perform device reset
44, Cmd044	Write primary variable units
45, Cmd045	Trim loop current zero
46, Cmd046	Trim loop current gain
50, Cmd050	Read dynamic variable assignments

Command No.	Description
54, Cmd054	Read device variable information
59, Cmd059	Write number of response preambles
72, Cmd072	Squawk
95, Cmd095	Read Device Communication Statistics
100, Cmd100	Write Primary Variable Alarm Code
516, Cmd516	Read Device Location
517, Cmd517	Write Device Location
518, Cmd518	Read Location Description
519, Cmd519	Write Location Description
520, Cmd520	Read Process Unit Tag
521, Cmd521	Write Process Unit Tag
523, Cmd523	Read Condensed Status Mapping Array
524, Cmd524	Write Condensed Status Mapping Array
525, Cmd525	Reset Condensed Status Mapping Array
526, Cmd526	Write Simulation Mode
527, Cmd527	Simulate Status Bit

## 8 Commissioning



### 8.1 Function check

Before commissioning the measuring point, make sure that all final checks have been carried out:

- "Post-mounting check" checklist →  14
- "Post-connection check" checklist →  19

### 8.2 Switching on the device

Once you have completed the post-connection checks, switch on the supply voltage. The transmitter performs a number of internal test functions after power-up. During this process, the following sequence of messages appears on the display:

Step	Indication
1	Text "Display" and firmware version of the display
2	Device name with firmware version, hardware version and device revision
3	Displays the sensor configuration (sensor element and type of connection) along with the configured measuring range
4a	Current measured value or
4b	Current status message   If the switch-on procedure is not successful, the relevant diagnostic event is displayed, depending on the cause. A detailed list of diagnostic events and the corresponding troubleshooting instructions can be found in the "Diagnostics and troubleshooting" section →  31.

The device works after approx. 7 seconds, including the attached display. Normal measuring mode commences as soon as the switch-on procedure is completed. Measured values and status values appear on the display.

 If the display is attached when the Bluetooth interface is activated, display initialization is performed twice and Bluetooth communication is disabled simultaneously.

## 8.3 Protecting settings from unauthorized access

### 8.3.1 Hardware locking

The device can be protected against unauthorized access by hardware locking. In the locking and access concept, hardware locking always has top priority. The device is write-protected if the lock symbol appears in the header of the measured value display. To unlock, switch the write protection switch on the back of the display to the "OFF" position (hardware write protection). →  22

### 8.3.2 Software locking

By assigning a password for the **Maintenance** user role, it is possible to restrict access authorization and protect the device against unauthorized access.

The parameters are also protected against modification by logging out of the **Maintenance** user role and switching to the **Operator** role. No lock symbol appears, however.

To disable the write protection, the user must log on with the **Maintenance** user role via the relevant operating tool.

 User role concept →  24

## 9 Diagnostics and troubleshooting

### 9.1 General troubleshooting

Always start troubleshooting with the checklists below if faults occur after startup or during operation. The checklists take you directly (via various queries) to the cause of the problem and the appropriate remedial measures.

 Due to its design, the device cannot be repaired. However, it is possible to send the device in for examination. See the information in the "Return" section.

#### General errors

Error	Possible cause	Remedial action
Device is not responding.	Supply voltage does not match the voltage specified on the nameplate.	Check the voltage at the transmitter directly using a voltmeter and correct.
	Connecting cables are not in contact with the terminals.	Check the contacting of the cables and terminals and correct if necessary.
	Electronics module is defective.	Replace the device.
Output current < 3.6 mA	Signal line is not wired correctly.	Check wiring.
	Electronics module is defective.	Replace the device.
HART communication does not work.	Missing or incorrectly installed communication resistor.	Install the communication resistor (250 Ω) correctly.
	HART modem is not properly connected.	Connect HART modem correctly.
	HART modem is not set to "HART".	Set HART modem selector switch to "HART".
Status LED is lit or flashing red (DIN rail transmitter only).	Diagnostic events as per NAMUR NE107 →  33	Check diagnostic events: <ul style="list-style-type: none"> <li>▪ LED is lit: diagnostic display, category F</li> <li>▪ LED flashing: diagnostic display of categories C, S or M</li> </ul>
Power LED is not lit green (DIN rail transmitter only).	Power failure or insufficient supply voltage	Check the supply voltage and check if wiring is correct.



#### Check display (optional in conjunction with head transmitter)

Error	Possible cause	Remedial action
Display is blank	No supply voltage	<ul style="list-style-type: none"> <li>▪ Check the supply voltage at the head transmitter, terminals + and -.</li> <li>▪ Ensure that the display module holders are correctly seated and that the display module is properly connected to the head transmitter; see Mounting section.</li> <li>▪ If possible, test the display module with other suitable head transmitters.</li> </ul>
	The display module is defective.	Replace the module.
	The electronics of the head transmitter is defective.	Replace the head transmitter.



Local error messages on the display
→  33



Faulty connection to the fieldbus host system		
Error	Possible cause	Remedial action
HART communication does not work.	Missing or incorrectly installed communication resistor.	Install the communication resistor (250 Ω) correctly.
	Commubox is connected incorrectly.	Connect Commubox correctly.



Error messages in the configuration software
→  33

#### Application errors without status messages for RTD sensor connection

Error	Possible cause	Remedial action
Measured value is incorrect/ inaccurate	Incorrect sensor orientation.	Install the sensor correctly.
	Heat conducted by sensor.	Observe the installation length of the sensor.
	Device programming is incorrect (number of wires).	Change the <b>Connection type</b> device function.
	Device programming is incorrect (scaling).	Change scaling.
	Incorrect RTD configured.	Change the <b>Sensor type</b> device function.
	Sensor connection.	Check that the sensor is connected correctly.
	The cable resistance of the sensor (2-wire) was not compensated.	Compensate the cable resistance.
	Offset incorrectly set.	Check offset.
Failure current ( $\leq 3.6$ mA or $\geq 21$ mA)	Sensor defective.	Check the sensor.
	RTD connected incorrectly.	Connect the connecting cables correctly (terminal diagram).
	Device programming is incorrect (e.g. number of wires).	Change the <b>Connection type</b> device function.
	Incorrect programming.	Incorrect sensor type set in the <b>Sensor type</b> device function. Set the correct sensor type.



#### Application errors without status messages for TC sensor connection

Error	Possible cause	Remedial action
Measured value is incorrect/ inaccurate	Incorrect sensor orientation.	Install the sensor correctly.
	Heat conducted by sensor.	Observe the installation length of the sensor.



Error	Possible cause	Remedial action
	Device programming is incorrect (scaling).	Change scaling.
	Incorrect thermocouple type (TC) configured.	Change the <b>Sensor type</b> device function.
	Incorrect reference junction set.	Set the correct reference junction .
	Interference via the thermocouple wire welded in the thermowell (interference voltage coupling).	Use a sensor where the thermocouple wire is not welded.
	Offset incorrectly set.	Check offset.
Failure current ( $\leq 3.6$ mA or $\geq 21$ mA)	Sensor defective.	Check the sensor.
	Sensor is connected incorrectly.	Connect the connecting cables correctly (terminal diagram).
	Incorrect programming.	Incorrect sensor type set in the <b>Sensor type</b> device function. Set the correct sensor type.

## 9.2 Diagnostic information on local display

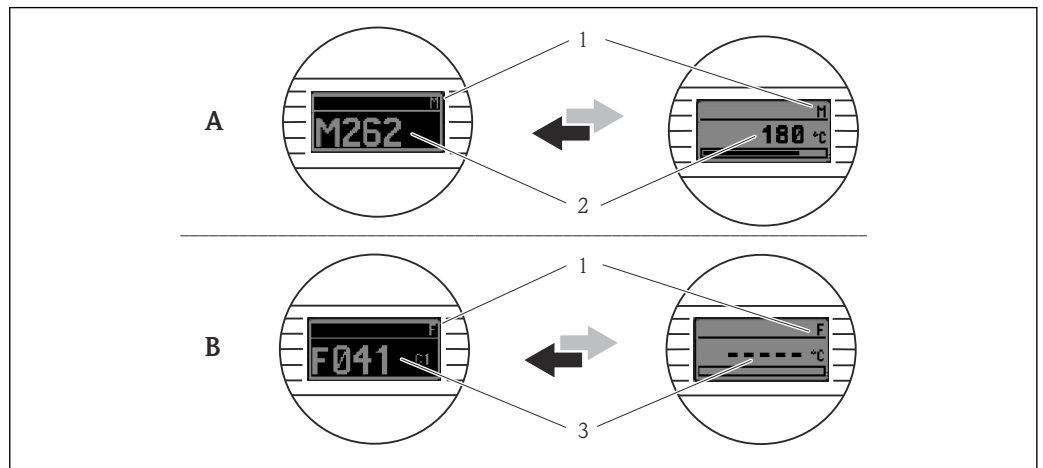

A0014837

- A Display in the event of a warning
- B Display in the event of an alarm
- 1 Status signal in the header
- 2 The display alternates between the primary measured value and the status - indicated by the appropriate letter (M, C or S) - plus the defined error number.
- 3 The display alternates between "- - -" (no valid measured value) and the status - indicated by the appropriate letter (F) - plus the defined error number.





## 9.3 Diagnostic information via communication interface

### NOTICE

Status signals and diagnostic behavior can be configured manually for certain diagnostic events. If a diagnostic event occurs, however, it is not guaranteed that the measured values are valid for the event and comply with the process for the status signals S and M and the diagnostic behavior: 'Warning' and Disabled'.

- Reset the status signal assignment to the factory setting.

*Status signals*

Letter/ symbol <sup>1)</sup>	Event category	Meaning
F 	Operating error	An operating error has occurred.
C 	Service mode	The device is in the service mode (e.g. during a simulation).
S 	Out of specification	The device is being operated outside its technical specifications (e.g. during startup or cleaning processes).
M 	Maintenance required	Maintenance is required.
N -	Not categorized	

1) As per NAMUR NE107

*Diagnostic behavior*

<b>Alarm</b>	Measurement is interrupted. The signal outputs assume the defined alarm condition. A diagnostic message is generated.
<b>Warning</b>	The device continues to measure. A diagnostic message is generated.
<b>Disabled</b>	The diagnosis is completely disabled even if the device is not recording a measured value.

## 9.4 Diagnostic list

If several diagnostic events are pending at the same time, only the diagnostic message with the highest priority is displayed. Additional pending diagnostic messages are shown in the **Diagnostic list** submenu. The following order of priority applies: F, C, S, M. If several diagnostic events with the same status signal are pending at the same time, the numerical order of the event number dictates the order of priority in which the events are displayed, e.g. F042 appears before F044 and before S044.

## 9.5 Event logbook

 Previous diagnostic messages are displayed in the **Event logbook** submenu. →  60

## 9.6 Overview of diagnostic events

Each diagnostic event is assigned a specific event behavior ex works. The user can change this assignment for certain diagnostic events.

*Example:*







Configuration examples	Diagnostic number	Settings		Device behavior			
		Status signal	Diagnostic behavior from the factory	Status signal (output via HART communication)	Current output	PV,status	Display
1. Default setting	047	S	Warning	S	Measured value	Measured value, UNCERTAIN	S047
2. Manual setting: status signal S changed to F	047	F	Warning	F	Measured value	Measured value, UNCERTAIN	F047

Configuration examples	Diagnostic number	Settings		Device behavior			
		Status signal	Diagnostic behavior from the factory	Status signal (output via HART communication)	Current output	PV,status	Display
3. Manual setting: <b>Warning</b> diagnostic behavior changed to <b>Alarm</b>	047	S	Alarm	S	Configured failure current	Measured value, BAD	S047
4. Manual setting: <b>Warning</b> changed to <b>Disabled</b>	047	S <sup>1)</sup>	Disabled	- <sup>2)</sup>	Last valid measured value <sup>3)</sup>	Last valid measured value, GOOD	S047

1) Setting is not relevant.

2) Status signal is not displayed.

3) The failure current is output if no valid measured value is available.

Diagnostic number	Short text	Remedial action	Status signal from the factory		Diagnostic behavior from the factory	
				Customizable <sup>1)</sup>		Not customizable
<b>Diagnostics for the sensor</b>						
041	Sensor interrupted	1. Check electrical wiring. 2. Replace sensor. 3. Check configuration of connection type.	F		Alarm	
042	Sensor corroded	1. Check sensor. 2. Replace sensor.	M		Warning	
043	Short-circuit	1. Check electrical connection. 2. Check sensor. 3. Replace sensor or cable.	F		Alarm	
047	Sensor limit reached, sensor n	1. Check sensor. 2. Check process conditions.	S		Warning	
145	Compensation reference junction	1. Check terminal temperature. 2. Check external reference measuring point.	F		Alarm	
<b>Diagnostics for the electronics</b>						
201	Electronics faulty	1. Restart device. 2. Replace electronics.	F		Alarm	
221	Reference sensor defective	Replace device.	M		Alarm	
<b>Diagnostics for the configuration</b>						
401	Factory reset active	Factory reset in progress, please wait.	C		Warning	
402	Initialization is active	Initialization in progress, please wait.	C		Warning	
410	Data transfer failed	1. Check connection. 2. Repeat data transfer.	F		Alarm	
411	Upload/download active	Upload/download in progress, please wait.	C		Warning	
435	Linearization incorrect	Check linearization.	F		Alarm	
485	Simulation of the process variable is active	Deactivate simulation.	C		Warning	

Diagnostic number	Short text	Remedial action	Status signal from the factory	✓	Diagnostic behavior from the factory	✓
				Customizable <sup>1)</sup>		Not customizable
491	Current output simulation	Deactivate simulation.	C	✓	Warning	✓
495	Diagnostic event simulation active	Deactivate simulation.	C	✓	Warning	✓
531	Factory calibration missing	1. Contact service organization. 2. Replace device.	F	✗	Alarm	✗
537	Configuration	1. Check device configuration 2. Upload and download new configuration. (In case of current output: check configuration of analog output.)	F	✗	Alarm	✗
582	Sensor diagnostics TC deactivated	Switch on diagnostics for thermocouple measurement	C	✗	Warning	✗
<b>Diagnostics for the process</b>						
801	Supply voltage too low <sup>3)</sup>	Increase supply voltage.	S	✓	Alarm	✗
825	Operating temperature	1. Check ambient temperature. 2. Check process temperature.	S	✓	Warning	✓
844	Process value out of specification	1. Check process value. 2. Check application. Check sensor. 3. Check scaling of analog output	S	✓	Warning	✓

1) Can be set to F, C, S, M, N

2) Can be set to 'Alarm', 'Warning' and 'Disabled'

3) With this diagnostic event, the device always outputs a "low" alarm status (output current  $\leq 3.6$  mA).

## 10 Maintenance and cleaning

No special maintenance work is required for the device.

### 10.1 Cleaning of surfaces not in contact with the medium

- Recommendation: Use a lint-free cloth that is either dry or slightly dampened using water.
- Do not use any sharp objects or aggressive cleaning agents that corrode the surfaces (displays, housing, for example) and seals.
- Do not use high-pressure steam.
- Observe the degree of protection of the device.

**i** The cleaning agent used must be compatible with the materials of the device configuration. Do not use cleaning agents with concentrated mineral acids, bases or organic solvents.

## 11 Repair

### 11.1 General notes

Due to its design, the device cannot be repaired.

### 11.2 Spare parts

Ask your supplier for information on the spare parts available.

Type
Standard - DIN mounting set (2 screws and springs, 4 shaft lock-down rings, 1 plug for the display interface)
US - M4 mounting set (2 screws and 1 plug for the display interface)
Connecting cable for service interface, 40 cm

### 11.3 Return

The requirements for safe device return can vary depending on the device type and national legislation. Please contact your supplier for further information.

### 11.4 Disposal



If required by the Directive 2012/19/EU on waste electrical and electronic equipment (WEEE), the product is marked with the depicted symbol in order to minimize the disposal of WEEE as unsorted municipal waste. Do not dispose of products bearing this marking as unsorted municipal waste. Instead, return them to the manufacturer for disposal under the applicable conditions.

## 12 Accessories

Various accessories, which can be ordered separately from your supplier, are available for the device. Contact your service organization for detailed information on the relevant order code. When ordering accessories, please quote the serial number of the device!

Accessories included in the scope of delivery:

- Brief Operating Instructions
- Supplementary ATEX documentation
- Mounting material for head transmitter, optional

Accessories
Attachable display unit
Field housing head transmitter (on request), aluminum, IP 66, dimensions B x H x D: 100 x 100 x 60 mm (3.94" x 3.94" x 2.36")
Adapter for DIN rail mounting, clip as per IEC 60715 (TH35)
Standard - DIN mounting set (2 screws + springs, 4 securing disks and 1 display connector cover)
US - M4 Mounting screws (2 M4 screws and 1 display connector cover)

## 13 Technical data

### 13.1 Input

Measured variable Temperature (temperature-linear transmission behavior), resistance and voltage.

Resistance thermometer (RTD) as per standard	Description	$\alpha$	Measuring range limits	Min. span
IEC 60751:2008	Pt100 (1) Pt200 (2) Pt500 (3) Pt1000 (4)	0.003851	-200 to +850 °C (-328 to +1562 °F) -200 to +850 °C (-328 to +1562 °F) -200 to +500 °C (-328 to +932 °F) -200 to +250 °C (-328 to +482 °F)	10 K (18 °F)
JIS C1604:1984	Pt100 (5)	0.003916	-200 to +510 °C (-328 to +950 °F)	10 K (18 °F)
DIN 43760 IPTS-68	Ni100 (6) Ni120 (7)	0.006180	-60 to +250 °C (-76 to +482 °F) -60 to +250 °C (-76 to +482 °F)	10 K (18 °F)
GOST 6651-94	Pt50 (8) Pt100 (9)	0.003910	-185 to +1100 °C (-301 to +2012 °F) -200 to +850 °C (-328 to +1562 °F)	10 K (18 °F)
OIML R84: 2003, GOST 6651-2009	Cu50 (10) Cu100 (11)	0.004280	-180 to +200 °C (-292 to +392 °F) -180 to +200 °C (-292 to +392 °F)	10 K (18 °F)
	Ni100 (12) Ni120 (13)	0.006170	-60 to +180 °C (-76 to +356 °F) -60 to +180 °C (-76 to +356 °F)	10 K (18 °F)
OIML R84: 2003, GOST 6651-94	Cu50 (14)	0.004260	-50 to +200 °C (-58 to +392 °F)	10 K (18 °F)
-	Pt100 (Callendar van Dusen) Nickel polynomial Copper polynomial	-	The measuring range limits are specified by entering the limit values that depend on the coefficients A to C and R0.	10 K (18 °F)
<ul style="list-style-type: none"> <li>■ Connection type: 2-wire, 3-wire or 4-wire connection, sensor current: ≤ 0.3 mA</li> <li>■ With 2-wire circuit, compensation of wire resistance possible (0 to 30 Ω)</li> <li>■ With 3-wire and 4-wire connection, sensor wire resistance up to max. 50 Ω per wire</li> </ul>				
Resistance transmitter	Resistance Ω		10 to 400 Ω 10 to 2000 Ω	10 Ω 10 Ω

Thermocouples as per standard	Description	Measuring range limits		Min. span
IEC 60584, Part 1 ASTM E230-3	Type A (W5Re-W20Re) (30)	0 to +2500 °C (+32 to +4532 °F)	Recommended temperature range: 0 to +2500 °C (+32 to +4532 °F)	50 K (90 °F)
	Type B (PtRh30-PtRh6) (31)	+40 to +1820 °C (+104 to +3308 °F)	+500 to +1820 °C (+932 to +3308 °F)	50 K (90 °F)
	Type E (NiCr-CuNi) (34)	-250 to +1000 °C (-482 to +1832 °F)	-150 to +1000 °C (-238 to +1832 °F)	50 K (90 °F)
	Type J (Fe-CuNi) (35)	-210 to +1200 °C (-346 to +2192 °F)	-150 to +1200 °C (-238 to +2192 °F)	50 K (90 °F)
	Type K (NiCr-Ni) (36)	-270 to +1372 °C (-454 to +2501 °F)	-150 to +1200 °C (-238 to +2192 °F)	50 K (90 °F)
	Type N (NiCrSi-NiSi) (37)	-270 to +1300 °C (-454 to +2372 °F)	-150 to +1300 °C (-238 to +2372 °F)	50 K (90 °F)
	Type R (PtRh13-Pt) (38)	-50 to +1768 °C (-58 to +3214 °F)	+200 to +1768 °C (+392 to +3214 °F)	50 K (90 °F)
	Type S (PtRh10-Pt) (39)	-50 to +1768 °C (-58 to +3214 °F)	+200 to +1768 °C (+392 to +3214 °F)	50 K (90 °F)
Type T (Cu-CuNi) (40)	-200 to +400 °C (-328 to +752 °F)	-150 to +400 °C (-238 to +752 °F)	50 K (90 °F)	
IEC 60584, Part 1 ASTM E230-3 ASTM E988-96	Type C (W5Re-W26Re) (32)	0 to +2315 °C (+32 to +4199 °F)	0 to +2000 °C (+32 to +3632 °F)	50 K (90 °F)
ASTM E988-96	Type D (W3Re-W25Re) (33)	0 to +2315 °C (+32 to +4199 °F)	0 to +2000 °C (+32 to +3632 °F)	50 K (90 °F)
DIN 43710	Type L (Fe-CuNi) (41)	-200 to +900 °C (-328 to +1652 °F)	-150 to +900 °C (-238 to +1652 °F)	50 K (90 °F)
	Type U (Cu-CuNi) (42)	-200 to +600 °C (-328 to +1112 °F)	-150 to +600 °C (-238 to +1112 °F)	50 K (90 °F)
GOST R8.585-2001	Type L (NiCr-CuNi) (43)	-200 to +800 °C (-328 to +1472 °F)	-200 to +800 °C (+328 to +1472 °F)	50 K (90 °F)

Thermocouples as per standard	Description	Measuring range limits	Min. span
	<ul style="list-style-type: none"> <li>Internal reference junction (Pt100)</li> <li>External preset value: configurable value -40 to +85 °C (-40 to +185 °F)</li> <li>Maximum sensor wire resistance 10 kΩ (If the sensor wire resistance is greater than 10 kΩ, an error message is output in accordance with NAMUR NE89.)</li> </ul>		
Voltage transmitter (mV)	Millivolt transmitter (mV)	-20 to +100 mV	5 mV

## 13.2 Output

Output signal	Analog output	4 to 20 mA, 20 to 4 mA (can be inverted)
	Signal encoding	FSK ±0.5 mA via current signal
	Data transmission rate	1200 baud
	Galvanic isolation	U = 2 kV AC for 1 minute (input/output)

### Failure information

#### Failure information as per NAMUR NE43:

Failure information is created if the measuring information is missing or not valid. A complete list of all the errors occurring in the measuring system is created.

Underranging	Linear decrease from 4.0 to 3.8 mA
Overranging	Linear increase from 20.0 to 20.5 mA
Failure e.g. sensor failure; sensor short-circuit	≤ 3.6 mA ("low") or ≥ 21 mA ("high"), can be selected The "high" alarm setting can be set between 21.5 mA and 23 mA, thus providing the flexibility needed to meet the requirements of various control systems.

### Load

Head transmitter: $R_{b \max} = (U_{b \max} - 10 \text{ V}) / 0.023 \text{ A}$ (current output)	<p style="text-align: right; font-size: small;">A0048539</p>
Din rail transmitter: $R_{b \max} = (U_{b \max} - 11 \text{ V}) / 0.023 \text{ A}$ (current output)	<p style="text-align: right; font-size: small;">A0055362</p>

Load in Ω.  $U_b$  = supply voltage in V DC

Linearization/transmission behavior Temperature-linear, resistance-linear, voltage-linear

Mains frequency filter 50/60 Hz

Filter 1st order digital filter: 0 to 120 s

Protocol-specific data

Manufacturer ID	17 (0x11)
Device type ID	0x11D0
HART specification	7
Device address in multi-drop mode	Software setting addresses 0 to 63
Device description files (DTM, DD)	Information and files available at: www.fieldcommgroup.org
HART load	Min. 250 Ω
HART device variables	<p><b>Measured value for primary value (PV)</b> Sensor (measured value)</p> <p><b>Measured values for SV, TV, QV (secondary, tertiary and quaternary variable)</b></p> <ul style="list-style-type: none"> <li>▪ SV: device temperature</li> <li>▪ TV: sensor (measured value)</li> <li>▪ QV: sensor (measured value)</li> </ul>
Supported functions	<ul style="list-style-type: none"> <li>▪ Squawk</li> <li>▪ Condensed status</li> </ul>

*Wireless HART data*

Minimum starting voltage	10 V <sub>DC</sub>
Starting current	3.58 mA
Starting time	7 s
Minimum operating voltage	10 V <sub>DC</sub>
Multidrop current	4.0 mA
Time for connection setup	9 s

Write protection for device parameters

- Hardware: Write protection for head transmitter on optional display using DIP switch
- Software: user role concept (password assignment)

Switch-on delay ≤ 7 s, until the first measured value signal is present at the current output. While switch-on delay =  $I_a \leq 3.8 \text{ mA}$

### 13.3 Power supply

Supply voltage

Values for non-hazardous areas, protected against polarity reversal:

- Head transmitter: 10 V ≤ V<sub>CC</sub> ≤ 36 V
- Din rail transmitter: 11 V ≤ V<sub>CC</sub> ≤ 36 V

Values for hazardous area; see Ex documentation.



Current consumption	<ul style="list-style-type: none"> <li>■ 3.6 to 23 mA</li> <li>■ Minimum current consumption 3.5 mA</li> <li>■ Current limit <math>\leq 23</math> mA</li> </ul>
---------------------	---

Terminals Choice of screw terminals or push-in terminals for sensor and power supply cables:

Terminal design	Cable design	Cable cross-section
Screw terminals	Rigid or flexible	$\leq 2.5$ mm <sup>2</sup> (14 AWG)
Push-in terminals (cable version, stripping length = min. 10 mm (0.39 in))	Rigid or flexible	0.2 to 1.5 mm <sup>2</sup> (24 to 16 AWG)
	Flexible with wire end ferrules with/without plastic ferrule	0.25 to 1.5 mm <sup>2</sup> (24 to 16 AWG)

 Ferrules must be used with push-in terminals and when using flexible cables with a cable cross-section of  $\leq 0.3$  mm<sup>2</sup>. Otherwise, the use of ferrules when connecting flexible cables to push-in terminals is not recommended.

## 13.4 Performance characteristics

Response time	Resistance thermometer (RTD) and resistance transmitter ( $\Omega$ measurement)	$\leq 1$ s
	Thermocouples (TC) and voltage transmitters (mV)	$\leq 1$ s
	Reference temperature	$\leq 1$ s

 When recording step responses, it must be taken into account that the times of the internal reference measuring point are added to the specified times where applicable.

Update time  $\leq 100$  ms

Reference conditions

- Calibration temperature:  $+25$  °C  $\pm 3$  K ( $77$  °F  $\pm 5.4$  °F)
- Supply voltage: 24 V DC
- 4-wire circuit for resistance adjustment

Maximum measurement error In accordance with DIN EN 60770 and the reference conditions specified above. The measurement error data corresponds to  $\pm 2 \sigma$  (Gaussian distribution). The data includes non-linearities and repeatability.

MV = measured value

LRV = lower range value of the sensor in question

MR = measuring range of the sensor in question

Typically

Standard	Description	Measuring range	Typical measurement error ( $\pm$ )	
Resistance thermometer (RTD) as per standard			Digital value <sup>1)</sup>	Value at current output
IEC 60751:2008	Pt100 (1)	0 to $+200$ °C ( $32$ to $+392$ °F)	0.07 °C (0.13 °F)	0.10 °C (0.18 °F)
IEC 60751:2008	Pt1000 (4)		0.05 °C (0.09 °F)	0.08 °C (0.14 °F)
GOST 6651-94	Pt100 (9)		0.06 °C (0.11 °F)	0.09 °C (0.16 °F)

Standard	Description	Measuring range	Typical measurement error (±)	
<b>Thermocouples (TC) as per standard</b>			Digital value <sup>1)</sup>	Value at current output
IEC 60584, Part 1	Type K (NiCr-Ni) (36)	0 to +800 °C (32 to +1 472 °F)	0.26 °C (0.47 °F)	0.35 °C (0.63 °F)
	Type R (PtRh13-Pt) (38)		0.46 °C (0.83 °F)	0.52 °C (0.94 °F)
	Type S (PtRh10-Pt) (39)		0.55 °C (0.99 °F)	0.60 °C (1.08 °F)

1) Measured value transmitted via HART

Measurement error for resistance thermometers (RTD) and resistance transmitters

Standard	Description	Measuring range	Measurement error (±)	
			Digital <sup>1)</sup>	D/A <sup>2)</sup>
			Based on measured value <sup>3)</sup>	
IEC 60751:2008	Pt100 (1)	-200 to +850 °C (-328 to +1 562 °F)	ME = ± (0.05 °C (0.09 °F) + 0.006% * (MV - LRV))	
	Pt200 (2)		ME = ± (0.08 °C (0.14 °F) + 0.011% * (MV - LRV))	
	Pt500 (3)	-200 to +510 °C (-328 to +950 °F)	ME = ± (0.035 °C (0.063 °F) + 0.008% * (MV - LRV))	
	Pt1000 (4)	-200 to +250 °C (-328 to +482 °F)	ME = ± (0.02 °C (0.04 °F) + 0.007% * (MV - LRV))	
JIS C1604:1984	Pt100 (5)	-200 to +510 °C (-328 to +950 °F)	ME = ± (0.045 °C (0.08 °F) + 0.006% * (MV - LRV))	
GOST 6651-94	Pt50 (8)	-185 to +1 100 °C (-301 to +2 012 °F)	ME = ± (0.08 °C (0.14 °F) + 0.008% * (MV - LRV))	
	Pt100 (9)	-200 to +850 °C (-328 to +1 562 °F)	ME = ± (0.045 °C (0.08 °F) + 0.006% * (MV - LRV))	
DIN 43760 IPTS-68	Ni100 (6)	-60 to +250 °C (-76 to +482 °F)	ME = ± (0.042 °C (0.07 °F) - 0.004% * (MV - LRV))	
	Ni120 (7)		ME = ± (0.04 °C (0.07 °F) - 0.004% * (MV - LRV))	
OIML R84: 2003 / GOST 6651-2009	Cu50 (10)	-180 to +200 °C (-292 to +392 °F)	ME = ± (0.08 °C (0.14 °F) + 0.006% * (MV - LRV))	
	Cu100 (11)	-180 to +200 °C (-292 to +392 °F)	ME = ± (0.04 °C (0.07 °F) + 0.003% * (MV - LRV))	
	Ni100 (12)	-60 to +180 °C (-76 to +356 °F)	ME = ± (0.04 °C (0.07 °F) - 0.004% * (MV - LRV))	
	Ni120 (13)		ME = ± (0.04 °C (0.07 °F) - 0.004% * (MV - LRV))	
OIML R84: 2003, GOST 6651-94	Cu50 (14)	-50 to +200 °C (-58 to +392 °F)	ME = ± (0.086 °C (0.004 °F) + 0.004% * (MV - LRV))	
<b>Resistance transmitter</b>	Resistance Ω	10 to 400 Ω	ME = ± 17 mΩ + 0.0032 % * MV	
		10 to 2 000 Ω	ME = ± 60 mΩ + 0.006 % * MV	

1) Measured value transmitted via HART

2) Percentages based on the configured measuring span of the analog output signal.

3) Deviations from maximum measurement error possible due to rounding.

## Measurement error for thermocouples (TC) and voltage transmitters

Standard	Description	Measuring range	Measurement error ( $\pm$ )	
			Digital <sup>1)</sup>	D/A <sup>2)</sup>
			Based on measured value <sup>3)</sup>	
IEC 60584-1 ASTM E230-3	Type A (30)	0 to +2 500 °C (+32 to +4 532 °F)	ME = $\pm$ (0.57 °C (1.03 °F) + 0.025% * (MV - LRV))	
	Type B (31)	+500 to +1 820 °C (+932 to +3 308 °F)	ME = $\pm$ (0.78 °C (1.4 °F) - 0.025% * (MV - LRV))	
IEC 60584-1 ASTM E230-3 ASTM E988-96	Type C (32)	0 to +2 000 °C (+32 to +3 632 °F)	ME = $\pm$ (0.28 °C (0.5 °F) + 0.011% * (MV - LRV))	
	Type D (33)		ME = $\pm$ (0.4 °C (0.72 °F) * (MV - LRV))	
IEC 60584-1 ASTM E230-3	Type E (34)	-150 to +1 000 °C (-238 to +1 832 °F)	ME = $\pm$ (0.13 °C (0.23 °F) - 0.001% * (MV - LRV))	
	Type J (35)	-150 to +1 200 °C (-238 to +2 192 °F)	ME = $\pm$ (0.17 °C (0.31 °F) * (MV - LRV))	
	Type K (36)		ME = $\pm$ (0.24 °C (0.43 °F) - 0.002% * (MV - LRV))	
	Type N (37)	-150 to +1 300 °C (-238 to +2 372 °F)	ME = $\pm$ (0.27 °C (0.49 °F) - 0.003% * (MV - LRV))	
	Type R (38)	+200 to +1 768 °C (+392 to +3 214 °F)	ME = $\pm$ (0.48 °C (0.86 °F) - 0.004% * (MV - LRV))	
	Type S (39)		ME = $\pm$ (0.54 °C (0.97 °F) - 0.002% * (MV - LRV))	
	Type T (40)	-150 to +400 °C (-238 to +752 °F)	ME = $\pm$ (0.24 °C (0.43 °F) - 0.02% * (MV - LRV))	
DIN 43710	Type L (41)	-150 to +900 °C (-238 to +1 652 °F)	ME = $\pm$ (0.2 °C (0.36 °F) - 0.002% * (MV - LRV))	
	Type U (42)	-150 to +600 °C (-238 to +1 112 °F)	ME = $\pm$ (0.27 °C (0.49 °F) - 0.019% * (MV - LRV))	
GOST R8.585-2001	Type L (43)	-200 to +800 °C (-328 to +1 472 °F)	ME = $\pm$ (2.2 °C (3.96 °F) - 0.005% * (MV - LRV))	
<b>Voltage transmitter (mV)</b>		-20 to +100 mV	ME = $\pm$ 10.0 $\mu$ V	

- 1) Measured value transmitted via HART
- 2) Percentages based on the configured measuring span of the analog output signal.
- 3) Deviations from maximum measurement error possible due to rounding.

Total measurement error of transmitter at current output =  $\sqrt{(\text{Measurement error digital}^2 + \text{Measurement error D/A}^2)}$

Sample calculation with Pt100, measuring range 0 to +200 °C (+32 to +392 °F), ambient temperature +25 °C (+77 °F), supply voltage 24 V:

Measurement error digital = 0.05 °C + 0.006% x (200 °C - (-200 °C)):	0.07 °C (0.126 °F)
Measurement error D/A = 0.03 % x 200 °C (360 °F)	0.06 °C (0.108 °F)
<b>Measurement error digital value (HART):</b>	0.07 °C (0.126 °F)
<b>Measurement error analog value (current output):</b> $\sqrt{(\text{measurement error digital}^2 + \text{measurement error D/A}^2)}$	0.10 °C (0.18 °F)

Sample calculation with Pt100, measuring range 0 to +200 °C (+32 to +392 °F), ambient temperature +35 °C (+95 °F), supply voltage 30 V:

Measurement error digital = 0.05 °C + 0.006% x (200 °C - (-200 °C)):	0.07 °C (0.126 °F)
Measurement error D/A = 0.03 % x 200 °C (360 °F)	0.06 °C (0.108 °F)
Influence of ambient temperature (digital) = (35 - 25) x (0.0013% x 200 °C - (-200 °C)), min. 0.003 °C	0.05 °C (0.09 °F)
Influence of ambient temperature (D/A) = (35 - 25) x (0.003% x 200 °C)	0.06 °C (0.108 °F)
Influence of supply voltage (digital) = (30 - 24) x (0.0007% x 200 °C - (-200 °C)), min. 0.005 °C	0.02 °C (0.036 °F)
Influence of supply voltage (D/A) = (30 - 24) x (0.003% x 200 °C)	0.04 °C (0.72 °F)
<b>Measurement error digital value (HART):</b> $\sqrt{(\text{Measurement error digital})^2 + \text{Influence of ambient temperature (digital)}^2 + \text{Influence of supply voltage (digital)}^2}$	<b>0.10 °C (0.18 °F)</b>
<b>Measurement error analog value (current output):</b> $\sqrt{(\text{Measurement error digital})^2 + \text{Measurement error D/A}^2 + \text{Influence of ambient temperature (digital)}^2 + \text{Influence of ambient temperature (D/A)}^2 + \text{Influence of supply voltage (digital)}^2 + \text{Influence of supply voltage (D/A)}^2}$	<b>0.13 °C (0.23 °F)</b>

The measurement error data corresponds to 2 σ (Gaussian distribution)

Physical input measuring range of sensors	
10 to 400 Ω	Cu50, Cu100, polynomial RTD, Pt50, Pt100, Ni100, Ni120
10 to 2 000 Ω	Pt200, Pt500, Pt1000
-20 to +100 mV	Thermocouples type: A, B, C, D, E, J, K, L, N, R, S, T, U

Sensor adjustment

**Sensor-transmitter matching**

RTD sensors are one of the most linear temperature measuring elements. Nevertheless, the output must be linearized. To significantly improve temperature measurement accuracy, the device allows the use of two methods:

- Callendar van Dusen coefficients (Pt100 resistance thermometer)

The Callendar van Dusen equation is described as:

$$R_T = R_0 [1 + AT + BT^2 + C(T - 100)T^3]$$

The coefficients A, B and C are used to match the sensor (platinum) and transmitter in order to improve the accuracy of the measuring system. The coefficients for a standard sensor are specified in IEC 751. If no standard sensor is available or if greater accuracy is required, the coefficients for each sensor can be determined specifically with the aid of sensor calibration.

- Linearization for copper/nickel resistance thermometers (RTD)

The polynomial equation for copper/nickel is as follows:

$$R_T = R_0 (1 + AT + BT^2)$$

The coefficients A and B are used for the linearization of nickel or copper resistance thermometers (RTD). The exact values of the coefficients derive from the calibration data and are specific to each sensor. The sensor-specific coefficients are then sent to the transmitter.

Sensor-transmitter-matching using one of the methods mentioned above significantly improves the temperature measurement accuracy of the entire system. This is because the transmitter uses the specific data pertaining to the connected sensor to calculate the measured temperature, instead of using the standardized sensor curve data.

**1-point adjustment (offset)**

Shifts the sensor value

Current output adjustment      Correction of the 4 or 20 mA current output value.

Operating influences      The measurement error data corresponds to 2  $\sigma$  (Gaussian distribution).*Influence of ambient temperature and supply voltage on operation for resistance thermometers (RTD) and resistance transmitters*

Description	Standard	Ambient temperature: Influence ( $\pm$ ) per 1 °C (1.8 °F) change		Supply voltage: Influence ( $\pm$ ) per V change	
		Digital <sup>1)</sup>	D/A <sup>2)</sup>	Digital <sup>1)</sup>	D/A <sup>2)</sup>
		Based on measured value		Based on measured value	
Pt100 (1)	IEC 60751:2008	0.0013% * (MV - LRV), at least 0.003 °C (0.005 °F)		0.0007% * (MV - LRV), at least 0.002 °C (0.004 °F)	
Pt200 (2)		$\leq 0.017$ °C (0.031 °F)		$\leq 0.009$ °C (0.016 °F)	
Pt500 (3)		0.0013% * (MV - LRV), at least 0.006 °C (0.011 °F)		0.0007% * (MV - LRV), at least 0.002 °C (0.004 °F)	
Pt1000 (4)		$\leq 0.005$ °C (0.009 °F)		$\leq 0.003$ °C (0.005 °F)	
Pt100 (5)	JIS C1604:1984	0.0013% * (MV - LRV), at least 0.003 °C (0.005 °F)		0.0007% * (MV - LRV), at least 0.001 °C (0.002 °F)	
Pt50 (8)	GOST 6651-94	0.0015% * (MV - LRV), at least 0.01 °C (0.018 °F)		0.0007% * (MV - LRV), at least 0.004 °C (0.007 °F)	
Pt100 (9)		0.0013% * (MV - LRV), at least 0.003 °C (0.005 °F)		0.0007% * (MV - LRV), at least 0.002 °C (0.004 °F)	
Ni100 (6)	DIN 43760 IPTS-68	$\leq 0.003$ °C (0.005 °F)		$\leq 0.001$ °C (0.002 °F)	
Ni120 (7)					
Cu50 (10)	OIML R84: 2003 / GOST 6651-2009	$\leq 0.005$ °C (0.009 °F)		$\leq 0.002$ °C (0.004 °F)	
Cu100 (11)		$\leq 0.004$ °C (0.007 °F)		$\leq 0.002$ °C (0.004 °F)	
Ni100 (12)		$\leq 0.003$ °C (0.005 °F)		$\leq 0.001$ °C (0.002 °F)	
Ni120 (13)					
Cu50 (14)	OIML R84: 2003 / GOST 6651-94	$\leq 0.005$ °C (0.009 °F)		$\leq 0.002$ °C (0.004 °F)	
<b>Resistance transmitter (<math>\Omega</math>)</b>					
10 to 400 $\Omega$		0.001% * MV, at least 1 m $\Omega$		0.0005% * MV, at least 1 m $\Omega$	
10 to 2000 $\Omega$		0.001% * MV, at least 10 m $\Omega$		0.0005% * MV, at least 5 m $\Omega$	

1) Measured value transmitted via HART

2) Percentages based on the configured measuring span of the analog output signal

*Influence of ambient temperature and supply voltage on operation for thermocouples (TC) and voltage transmitters*

Description	Standard	Ambient temperature: Influence ( $\pm$ ) per 1 °C (1.8 °F) change		Supply voltage: Influence ( $\pm$ ) per V change	
		Digital <sup>1)</sup>	D/A <sup>2)</sup>	Digital	D/A <sup>2)</sup>
		Based on measured value		Based on measured value	
Type A (30)	IEC 60584-1 ASTM E230-3	0.003% * (MV - LRV), at least 0.01 °C (0.018 °F)		0.0012% * (MV - LRV), at least 0.013 °C (0.023 °F)	

Description	Standard	Ambient temperature: Influence (±) per 1 °C (1.8 °F) change		Supply voltage: Influence (±) per V change	
		Digital <sup>1)</sup>	D/A <sup>2)</sup>	Digital	D/A <sup>2)</sup>
Type B (31)		≤ 0.04 °C (0.072 °F)		≤ 0.02 °C (0.036 °F)	
Type C (32)	IEC 60584-1 ASTM E230-3 ASTM E988-96	0.0021% * (MV - LRV), at least 0.01 °C (0.018 °F)		0.0012% * (MV - LRV), at least 0.013 °C (0.023 °F)	
Type D (33)	ASTM E988-96	0.0019% * (MV - LRV), at least 0.01 °C (0.018 °F)		0.0011% * (MV - LRV), at least 0.0 °C (0.0 °F)	
Type E (34)		0.0014% * (MV - LRV), at least 0.0 °C (0.0 °F)		0.0008% * (MV - LRV), at least 0.0 °C (0.0 °F)	
Type J (35)		0.0014% * (MV - LRV), at least 0.0 °C (0.0 °F)		0.0008% * MV, at least 0.0 °C (0.0 °F)	
Type K (36)		0.0015% * (MV - LRV), at least 0.0 °C (0.0 °F)		0.0009% * (MV - LRV), at least 0.0 °C (0.0 °F)	
Type N (37)	IEC 60584-1 ASTM E230-3	0.0014% * (MV - LRV), at least 0.02 °C (0.036 °F)		0.0008% * MV, at least 0.0 °C (0.0 °F)	
Type R (38)		≤ 0.03 °C (0.054 °F)		≤ 0.02 °C (0.036 °F)	
Type S (39)		≤ 0.03 °C (0.054 °F)		≤ 0.02 °C (0.036 °F)	
Type T (40)		≤ 0.01 °C (0.018 °F)	0.003 %	≤ 0.0 °C (0.0 °F)	0.003 %
Type L (41)		≤ 0.01 °C (0.018 °F)		≤ 0.01 °C (0.018 °F)	
Type U (42)	DIN 43710	≤ 0.01 °C (0.018 °F)		≤ 0.0 °C (0.0 °F)	
Type L (43)	GOST R8.585-2001	≤ 0.01 °C (0.018 °F)		≤ 0.01 °C (0.018 °F)	
<b>Voltage transmitter (mV)</b>					
-20 to 100 mV	-	0.0015% * MV	0.003 %	0.0008% * MV	0.003 %

- 1) Measured value transmitted via HART
- 2) Percentages based on the configured span of the analog output signal

MV = measured value

LRV = lower range value of the sensor in question

MR = measuring range of the sensor in question

Total measurement error of transmitter at current output =  $\sqrt{(\text{Measurement error digital}^2 + \text{Measurement error D/A}^2)}$

*Long-term drift, resistance thermometers (RTD) and resistance transmitters*

Description	Standard	Long-term drift (±) <sup>1)</sup>		
		after 1 year	after 3 years	after 5 years
		Based on measured value		
Pt100 (1)		≤ 0.007% * (MV - LRV) or 0.02 °C (0.04 °F)	≤ 0.0093% * (MV - LRV) or 0.03 °C (0.05 °F)	≤ 0.0102% * (MV - LRV) or 0.03 °C (0.05 °F)
Pt200 (2)		0.09 °C (0.17 °F)	0.12 °C (0.27 °F)	0.13 °C (0.24 °F)
Pt500 (3)	IEC 60751:2008	≤ 0.068% * (MV - LRV) or 0.03 °C (0.06 °F)	≤ 0.011% * (MV - LRV) or 0.03 °C (0.05 °F)	≤ 0.0124% * (MV - LRV) or 0.04 °C (0.07 °F)
Pt1000 (4)		≤ 0.0088% * (MV - LRV) or 0.02 °C (0.04 °F)	≤ 0.0114% * (MV - LRV) or 0.03 °C (0.05 °F)	≤ 0.013% * (MV - LRV) or 0.03 °C (0.05 °F)
Pt100 (5)	JIS C1604:1984	≤ 0.007% * (MV - LRV) or 0.02 °C (0.04 °F)	≤ 0.0093% * (MV - LRV) or 0.03 °C (0.05 °F)	≤ 0.0102% * (MV - LRV) or 0.03 °C (0.05 °F)
Pt50 (8)	GOST 6651-94	≤ 0.0076% * (MV - LRV) or 0.04 °C (0.08 °F)	≤ 0.01% * (MV - LRV) or 0.06 °C (0.11 °F)	≤ 0.011% * (MV - LRV) or 0.07 °C (0.12 °F)

Description	Standard	Long-term drift ( $\pm$ ) <sup>1)</sup>		
		$\leq 0.007\% * (MV - LRV)$ or 0.02 °C (0.04 °F)	$\leq 0.0093\% * (MV - LRV)$ or 0.03 °C (0.05 °F)	$\leq 0.0102\% * (MV - LRV)$ or 0.03 °C (0.05 °F)
Pt100 (9)				
Ni100 (6)	DIN 43760 IPTS-68	0.02 °C (0.04 °F)	0.02 °C (0.04 °F)	0.02 °C (0.04 °F)
Ni120 (7)				
Cu50 (10)	OIML R84: 2003 / GOST 6651-2009	0.04 °C (0.07 °F)	0.05 °C (0.09 °F)	0.05 °C (0.09 °F)
Cu100 (11)		0.02 °C (0.04 °F)	0.03 °C (0.05 °F)	0.04 °C (0.07 °F)
Ni100 (12)		0.02 °C (0.04 °F)	0.02 °C (0.04 °F)	0.02 °C (0.04 °F)
Ni120 (13)				
Cu50 (14)	OIML R84: 2003 / GOST 6651-94	0.04 °C (0.07 °F)	0.05 °C (0.09 °F)	0.05 °C (0.09 °F)
<b>Resistance transmitter</b>				
10 to 400 $\Omega$		$\leq 0.0055\% * MV$ or 7 m $\Omega$	$\leq 0.0073\% * MV$ or 10 m $\Omega$	$\leq 0.008\% * (MV - LRV)$ or 11 m $\Omega$
10 to 2000 $\Omega$		$\leq 0.007\% * (MV - LRV)$ or 47 m $\Omega$	$\leq 0.009\% * (MV - LRV)$ or 60 m $\Omega$	$\leq 0.0067\% * (MV - LRV)$ or 67 m $\Omega$

1) Whichever is greater

#### Long-term drift, thermocouples (TC) and voltage transmitters

Description	Standard	Long-term drift ( $\pm$ ) <sup>1)</sup>		
		after 1 year	after 3 years	after 5 years
		Based on measured value		
Type A (30)	IEC 60584-1 ASTM E230-3	$\leq 0.044\% * (MV - LRV)$ or 0.70 °C (1.26 °F)	$\leq 0.058\% * (MV - LRV)$ or 0.93 °C (1.67 °F)	$\leq 0.063\% * (MV - LRV)$ or 1.01 °C (1.82 °F)
Type B (31)		1.66 °C (2.99 °F)	2.19 °C (3.94 °F)	2.39 °C (4.30 °F)
Type C (32)	IEC 60584-1 ASTM E230-3 ASTM E988-96	0.70 °C (1.26 °F)	0.92 °C (1.66 °F)	1.00 °C (1.80 °F)
Type D (33)	ASTM E988-96	0.87 °C (1.57 °F)	1.15 °C (2.07 °F)	1.26 °C (2.27 °F)
Type E (34)	IEC 60584-1 ASTM E230-3	0.26 °C (0.47 °F)	0.34 °C (0.61 °F)	0.37 °C (0.67 °F)
Type J (35)		0.31 °C (0.56 °F)	0.41 °C (0.74 °F)	0.44 °C (0.79 °F)
Type K (36)		0.36 °C (0.65 °F)	0.47 °C (0.85 °F)	0.51 °C (0.92 °F)
Type N (37)		0.52 °C (0.94 °F)	0.69 °C (1.24 °F)	0.75 °C (1.35 °F)
Type R (38)		1.28 °C (2.30 °F)	1.69 °C (3.04 °F)	1.85 °C (3.33 °F)
Type S (39)		1.29 °C (2.32 °F)	1.70 °C (3.06 °F)	
Type T (40)		0.38 °C (0.68 °F)	0.50 °C (0.90 °F)	0.54 °C (0.97 °F)
Type L (41)		DIN 43710	0.25 °C (0.45 °F)	0.33 °C (0.59 °F)
Type U (42)	0.37 °C (0.67 °F)		0.49 °C (0.88 °F)	0.53 °C (0.95 °F)
Type L (43)	GOST R8.585-2001	0.31 °C (0.56 °F)	0.41 °C (0.74 °F)	0.44 °C (0.79 °F)
<b>Voltage transmitter (mV)</b>				
-20 to 100 mV		$\leq 0.025\% * MV$ or 8 $\mu V$	$\leq 0.033\% * MV$ or 11 $\mu V$	$\leq 0.036\% * MV$ or 12 $\mu V$

1) The larger value is valid

*Long-term drift analog output*

Long-term drift D/A <sup>1)</sup> (±)		
after 1 year	after 3 years	after 5 years
0.030%	0.036%	0.038%

1) Percentages based on the configured measuring span of the analog output signal.

Influence of the reference junction	Pt100 DIN IEC 60751 Cl. B (internal reference junction with thermocouples TC) If an external 2-wire Pt100 is used for the reference junction measurement, the measurement error caused by the transmitter is < 0.5 °C (0.9 °F). The measurement error of the sensor element also needs to be added.
-------------------------------------	--

### 13.5 Ambient conditions

Ambient temperature	<b>Head transmitter/DIN rail transmitter</b> -40 to +85 °C (-40 to +185 °F); for hazardous areas, see Ex documentation.
---------------------	---

Storage temperature	<b>Head transmitter</b> -50 to +100 °C (-58 to +212 °F)
	<b>DIN rail transmitter</b> -40 to +100 °C (-40 to +212 °F)

Operating altitude	Up to 4,000 m (4,374.5 yards) above sea level
--------------------	---

Humidity	<ul style="list-style-type: none"> <li>■ Condensation: <ul style="list-style-type: none"> <li>■ Head transmitter permitted</li> <li>■ DIN rail transmitter not permitted</li> </ul> </li> <li>■ Max. rel. humidity: 95% as per IEC 60068-2-30</li> </ul>
----------	--

Climate class	<ul style="list-style-type: none"> <li>■ Head transmitter: climate class C1 as per EN 60654-1</li> <li>■ DIN rail transmitter: climate class B2 as per IEC 60654-1</li> </ul>
---------------	---

Degree of protection	<ul style="list-style-type: none"> <li>■ Head transmitter with screw or push-in terminals: IP 20. In the installed state, it depends on the terminal head or field housing used.</li> <li>■ DIN rail transmitter: IP 20</li> </ul>
----------------------	--

Shock and vibration resistance	<p>Vibration resistance as per DNVGL-CG-0339: 2015 and DIN EN 60068-2-27</p> <ul style="list-style-type: none"> <li>■ Head transmitter: 2 to 100 Hz at 4g (increased vibration stress)</li> <li>■ DIN rail transmitter: 2 to 100 Hz at 0.7 g (general vibration stress)</li> </ul> <p>Shock resistance as per KTA 3505 (section 5.8.4 Shock test)</p>
--------------------------------	---

Electromagnetic compatibility (EMC)	<p><b>CE conformity</b></p> <p>Electromagnetic compatibility in accordance with all the relevant requirements of the IEC/EN 61326 series and NAMUR Recommendation EMC (NE21). For details, refer to the Declaration of Conformity. All tests were passed both with and without ongoing communication.</p> <p>Maximum measurement error &lt;1% of measuring range.</p> <p>Interference immunity as per IEC/EN 61326 series, industrial requirements</p>
-------------------------------------	--



Interference emission as per IEC/EN 61326 series, Class B equipment

Overvoltage category      Overvoltage category II

Pollution degree          Pollution degree 2

Protection class          Protection class III

## 13.6 Mechanical construction

Design, dimensions      Dimensions in mm (in)

*Head transmitter*

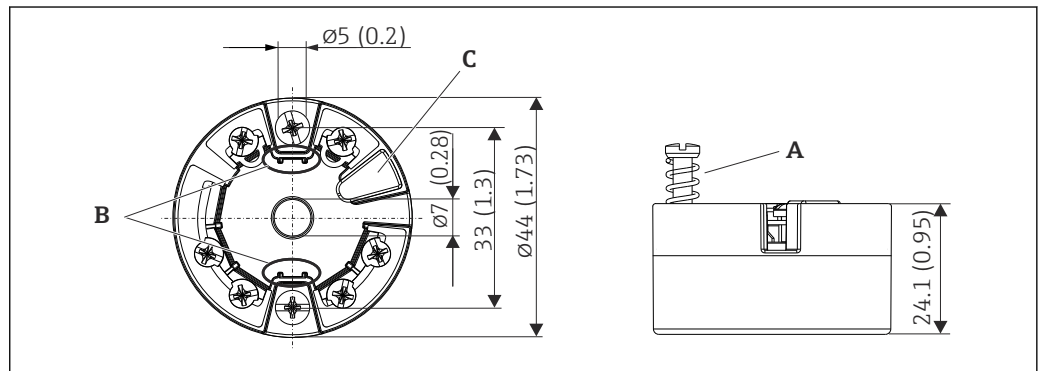

A0036303

▣ 18 Version with screw terminals

A Spring travel  $L \geq 5$  mm (not for US - M4 securing screws)

B Mounting elements for attachable measured value display TID10

C Interface for connecting measured value display or configuration tool

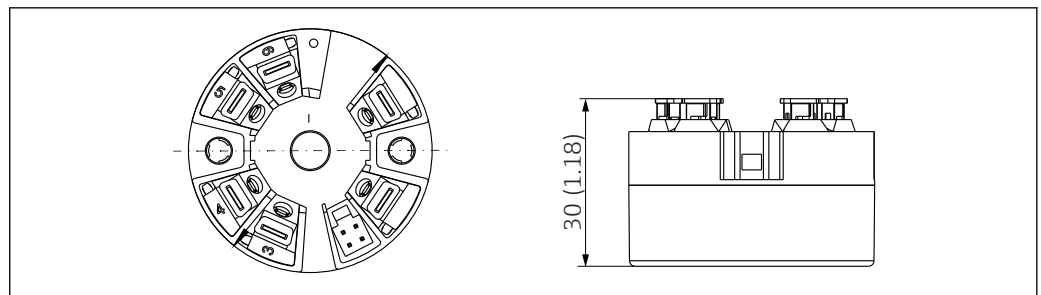

A0036304

▣ 19 Version with push-in terminals. Dimensions are identical to the version with screw terminals, apart from housing height.

*DIN rail device/version with power supply source at bottom*

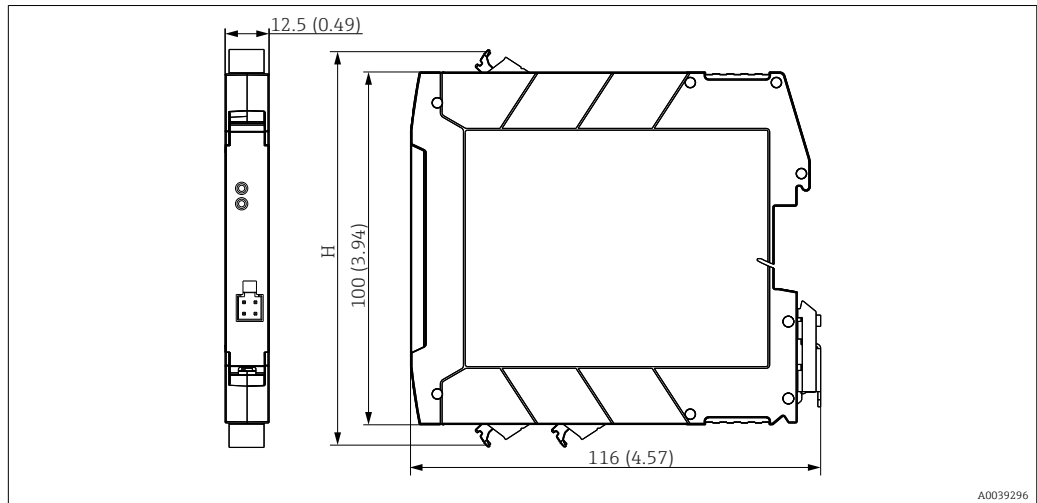

A0039296

Height of housing H varies depending on the terminal version:

- Screw terminals: H = 114 mm (4.49 in)
- Push-in terminals: H = 111.5 mm (4.39 in)

*DIN rail device/version with power supply source at top*

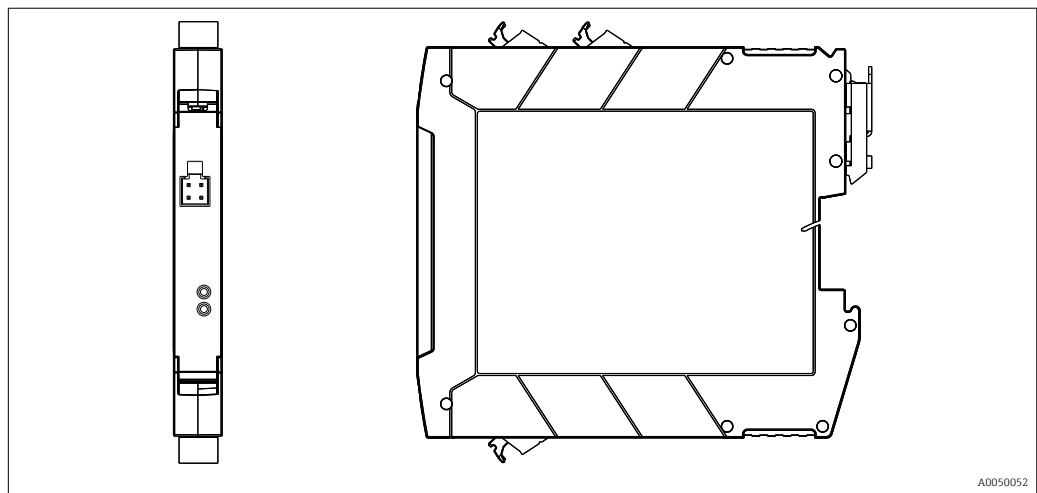

A0050052



**Field housing**

All field housings have an internal geometry in accordance with DIN EN 50446, Form B (flat face). Cable glands in the diagrams: M20x1.5

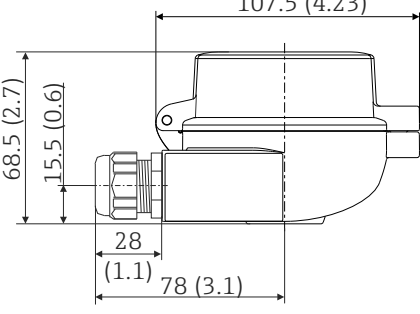
Maximum ambient temperatures for cable glands	
Type	Temperature range
Polyamide cable gland ½" NPT, M20x1.5 (non-Ex)	-40 to +100 °C (-40 to 212 °F)
Polyamide cable gland M20x1.5 (for dust ignition-proof area)	-20 to +95 °C (-4 to 203 °F)
Brass cable gland ½" NPT, M20x1.5 (for dust ignition-proof area)	-20 to +130 °C (-4 to +266 °F)

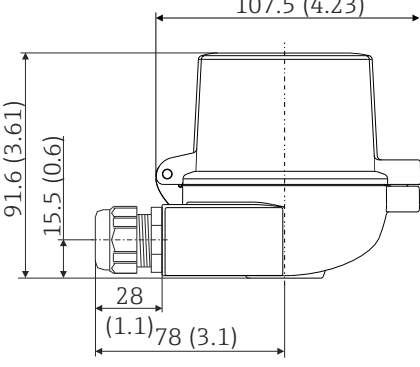
OTA30A	Specification
 <p style="text-align: right; font-size: small;">A0009820</p>	<ul style="list-style-type: none"> <li>▪ Two cable entries</li> <li>▪ Material: aluminum, polyester powder coated</li> <li>Seals: silicone</li> <li>▪ Degree of protection:                         <ul style="list-style-type: none"> <li>▪ IP66/68 (NEMA Type 4x encl.)</li> <li>▪ For ATEX: IP66/67</li> </ul> </li> <li>▪ Cable entry glands: ½" NPT and M20x1.5</li> <li>▪ Color: Gray</li> <li>▪ Weight: 330 g (11.64 oz)</li> </ul>

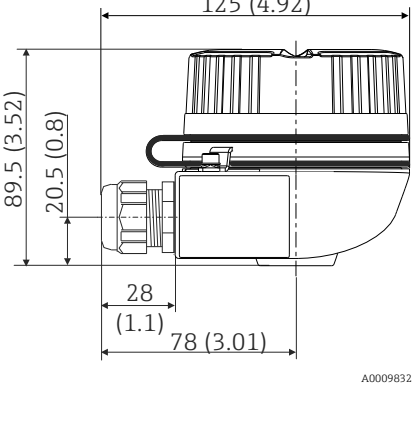
OTA30A with display window in cover	Specification
 <p style="text-align: right; font-size: small;">A0009821</p>	<ul style="list-style-type: none"> <li>▪ Two cable entries</li> <li>▪ Material: aluminum, polyester powder coated</li> <li>Seals: silicone</li> <li>▪ Degree of protection:                         <ul style="list-style-type: none"> <li>▪ IP66/68 (NEMA Type 4x encl.)</li> <li>▪ For ATEX: IP66/67</li> </ul> </li> <li>▪ Cable entry glands: ½" NPT and M20x1.5</li> <li>▪ Color: Gray</li> <li>▪ Weight: 420 g (14.81 oz)</li> <li>▪ Display window: single-pane safety glass according to DIN 8902</li> <li>▪ Display window in cover for head transmitter with TID10 display</li> </ul>

OTA30H	Specification
 <p style="text-align: right; font-size: small;">A0009832</p>	<ul style="list-style-type: none"> <li>▪ Flameproof (XP) version, explosion-protected, captive screw cap, with two cable entries</li> <li>▪ Degree of protection: IP 66/68, NEMA Type 4x Encl. Ex-version: IP 66/67</li> <li>▪ Material:                         <ul style="list-style-type: none"> <li>▪ Aluminum, with polyester powder coating</li> <li>▪ Stainless steel 316L without coating</li> <li>▪ Dry lubricant Klüber Syntheso Glep 1</li> </ul> </li> <li>▪ Cable entry glands: ½" NPT, M20x1.5</li> <li>▪ Color of aluminum head: Gray</li> <li>▪ Weight:                         <ul style="list-style-type: none"> <li>▪ Aluminum approx. 640 g (22.6 oz)</li> <li>▪ Stainless steel approx. 2 400 g (84.7 oz)</li> </ul> </li> </ul> <p>  When the housing cover is unscrewed: Before fastening, clean the threads in the cover and on the lower part of the housing and lubricate if necessary (recommended lubricant: Klüber Syntheso Glep 1).         </p>

OTA30H with display window in cover	Specification
	<ul style="list-style-type: none"> <li>■ Flameproof (XP) version, explosion-protected, captive screw cap, with two cable entries</li> <li>■ Degree of protection: IP 66/68, NEMA Type 4x Encl. Ex-version: IP 66/67</li> <li>■ Material:             <ul style="list-style-type: none"> <li>■ Aluminum with polyester powder coating</li> <li>■ Stainless steel 316L without coating</li> <li>■ Dry lubricant Klüber Syntheso Glep 1</li> </ul> </li> <li>■ Display window: single-pane safety glass according to DIN 8902</li> <li>■ Cable entry glands: ½" NPT, M20x1.5</li> <li>■ Color of aluminum head: Gray</li> <li>■ Weight:             <ul style="list-style-type: none"> <li>■ Aluminum approx. 860 g (30.33 oz)</li> <li>■ Stainless steel approx. 2 900 g (102.3 oz)</li> </ul> </li> <li>■ For display TID10</li> </ul> <p><b>i</b> When the housing cover is unscrewed: Before fastening, clean the threads in the cover and on the lower part of the housing and lubricate if necessary (recommended lubricant: Klüber Syntheso Glep 1).</p>

OTA30D	Specification
	<ul style="list-style-type: none"> <li>■ 2 cable entries</li> <li>■ Material: aluminum, polyester powder coated Seals: silicone</li> <li>■ Degree of protection:             <ul style="list-style-type: none"> <li>■ IP66/68 (NEMA Type 4x encl.)</li> <li>■ For ATEX: IP66/67</li> </ul> </li> <li>■ Cable entry glands: ½" NPT and M20x1.5</li> <li>■ Two head transmitters can be mounted. In the standard configuration one transmitter is mounted in the terminal head cover and an additional terminal block is installed directly on the insert.</li> <li>■ Color: Gray</li> <li>■ Weight: 390 g (13.75 oz)</li> </ul>

Weight

- Head transmitter: approx. 40 to 50 g (1.4 to 1.8 oz)
- DIN rail device: approx. 100 g (3.53 oz)
- Field housing: see specifications

Materials

All the materials used are RoHS-compliant.

- Housing: polycarbonate (PC)
- Terminals:
  - Screw terminals: nickel-plated brass and gold-plated or tin-plated contacts
  - Push-in terminals: tin-plated brass, contact springs 1.43 10, 301 (AISI)
- Potting compound:
  - Head transmitter: QSIL 553
  - DIN rail housing: Silgel612EH

Field housing: see specifications

## 13.7 Certificates and approvals

Currently available certificates and approvals for the product are available from the supplier.

HART certification	The temperature transmitter is registered by the FieldComm Group. The device meets the requirements of the FieldComm Group HART Specifications, Revision 7.
--------------------	---

Radio approval	The device has Bluetooth radio approval in accordance with the Radio Equipment Directive (RED) and the Federal Communications Commission (FCC) 15.247 for the USA.
----------------	--

Europe	
This device meets the requirements of the Radio Equipment Directive RED 2014/53/EU:	<ul style="list-style-type: none"> <li>▪ EN 300 328</li> <li>▪ EN 301 489-1</li> <li>▪ EN 301 489-17</li> </ul>

Canada and United States	
<p>English:</p> <p>This device complies with Part 15 of the FCC Rules and with Industry Canada license exempt RSS standard(s).</p> <p>Operation is subject to the following two conditions:</p> <ul style="list-style-type: none"> <li>▪ This device may not cause harmful interference, and</li> <li>▪ This device must accept any interference received, including interference that may cause undesired operation.</li> </ul> <p>Changes or modifications made to this equipment not expressly approved by the manufacturer may void the user's authorization to operate this equipment.</p> <p>This equipment has been tested and found to comply with the limits for a Class B digital device, pursuant to part 15 of the FCC Rules. These limits are designed to provide reasonable protection against harmful interference in a residential installation. This equipment generates, uses and can radiate radio frequency energy and, if not installed and used in accordance with the instructions, may cause harmful interference to radio communications. However, there is no guarantee that interference will not occur in a particular installation.</p> <p>If this equipment does cause harmful interference to radio or television reception, which can be determined by turning the equipment off and on, the user is encouraged to try to correct the interference by one or more of the following measures:</p> <ul style="list-style-type: none"> <li>▪ Reorient or relocate the receiving antenna.</li> <li>▪ Increase the separation between the equipment and receiver.</li> <li>▪ Connect the equipment into an outlet on a circuit different from that to which the receiver is connected.</li> <li>▪ Consult the dealer or an experienced radio/TV technician for help.</li> </ul> <p>This equipment complies with FCC and IC radiation exposure limits set forth for an uncontrolled environment. This equipment should be installed and operated with minimum distance 20cm between the radiator and your body.</p>	<p>Français:</p> <p>Le présent appareil est conforme aux CNR d'industrie Canada applicables aux appareils radio exempts de licence.</p> <p>L'exploitation est autorisée aux deux conditions suivantes :</p> <ul style="list-style-type: none"> <li>▪ L'appareil ne doit pas produire de brouillage, et</li> <li>▪ L'utilisateur de l'appareil doit accepter tout brouillage radioélectrique subi, même si le brouillage est susceptible d'en compromettre le fonctionnement.</li> </ul> <p>Les changements ou modifications apportées à cet appareil non expressément approuvée par le fabricant peut annuler l'autorisation de l'utilisateur d'opérer cet appareil.</p> <p>Déclaration d'exposition aux radiations: Cet équipement est conforme aux limites d'exposition aux rayonnements IC établies pour un environnement non contrôlé. Cet équipement doit être installé et utilisé avec un minimum de 20 cm de distance entre la source de rayonnement et votre corps.</p>

---

**MTTF**

- Without Bluetooth wireless technology: 168 years
- With Bluetooth wireless technology: 123 years



























The mean time to failure (MTTF) denotes the theoretically expected time until the device fails during normal operation. The term MTTF is used for systems that cannot be repaired, e.g. temperature transmitters.







## 14 Operating menu and parameter description







 The following tables list all the parameters in the Expert mode that are contained in the "Diagnostics, Application and System" operating menus. The page number refers to where a description of the parameter can be found.





Depending on the parameter configuration, not all submenus and parameters are available in every device. Information on this can be found in the parameter description under "Prerequisite".







This symbol  indicates how to navigate to the parameter using operating tools.







Diagnostics →	Actual diagnostics →	Actual diagnostics 1	→  59	
		Operating time	→  59	
Diagnostics →	Diagnostic list →	Actual diagnostics 1, 2, 3	→  59	
		Actual diag channel 1, 2, 3	→  59	
		Time stamp 1, 2, 3	→  60	
Diagnostics →	Event logbook →	Previous diagnostics n	→  60	
		Previous diag n channel	→  60	
		Time stamp n	→  61	
Diagnostics →	Simulation →	Diagnostic event simulation	→  61	
		Current output simulation	→  61	
		Value current output	→  61	
		Sensor simulation	→  62	
		Sensor simulation value	→  62	
Diagnostics →	Diagnostic settings →	Properties →	Alarm delay	→  62
			Limit corrosion detection	→  63
			Sensor line resistance	→  63
			Thermocouple diagnostic	→  63
			Diagnostic behavior →	→  63
			Sensor, electronics, process, configuration	
			Status signal →	→  64
			Sensor, electronics, process, configuration	
Diagnostics →	Min/max values →	Sensor min value	→  64	
		Sensor max value	→  64	
		Reset sensor min/max values	→  64	
		Device temperature min.	→  65	
		Device temperature max.	→  65	
		Reset device temp. min/max values	→  65	
Application →	Measured values →	Sensor value	→  65	
		Sensor raw value	→  65	







	Output current	→  65
	Percent of range	→  65
	Device temperature	→  65
	PV	→  66
	SV	→  66
	TV	→  67
	QV	→  67

<b>Application →</b>	<b>Sensor →</b>	Unit	→  67
		Sensor type	→  67
		Connection type	→  68
		2-wire compensation	→  68
		Reference junction	→  68
		RJ preset value	→  69
		Sensor offset	→  69



<b>Application →</b>	<b>Sensor →</b>	<b>Linearization →</b>	Call./v. Dusen coeff. R0, A, B, C	→  69
			Polynomial coeff. R0, A, B	→  70
			Sensor lower limit	→  70
			Sensor upper limit	→  71













<b>Application →</b>	<b>Current output →</b>	4mA value	→  71
		20mA value	→  71
		Failure mode	→  72
		Failure current	→  72
		Current trimming 4 mA	→  73
		Current trimming 20 mA	→  73
		Damping	→  73

<b>Application →</b>	<b>HART configuration →</b>	Assign current output (PV)	→  74
		Assign SV	→  74
		Assign TV	→  74
		Assign QV	→  74
		HART address	→  75
		No. of preambles	→  75



<b>System →</b>	<b>Device management →</b>	HART short tag	→  75
		Device tag	→  76
		Mains filter	→  76
		Locking status	→  76
		Device reset	→  76
		Configuration counter	→  77











	Configuration changed	→  77
	Reset configuration changed flag	→  77

<b>System →</b>	<b>User management →</b>	<b>Define password →</b>	New password	→  78
			Confirm new password	→  79
			Status password entry	→  79
		<b>Change user role →</b>	Password <sup>1)</sup>	→  79
			Status password entry	→  79
		<b>Reset password →</b>	Reset password	→  80
			Status password entry	→  80
		<b>Change password →</b>	Old password	→  81
			New password	→  81
			Confirm new password	→  81
			Status password entry	→  81
		<b>Delete password →</b>	Delete password	→  81







1) The required user role must first be selected here when operating the device via the Configuration app.





<b>System →</b>	<b>Bluetooth configuration →</b>	Bluetooth	→  81
		Change Bluetooth password <sup>1)</sup>	→  82







1) Function is only visible in the Configuration app









<b>System →</b>	<b>Information →</b>	<b>Device →</b>	Squawk	→  82
			Serial number	→  82
			Order code	→  83
			Firmware version	→  83
			Hardware revision	→  83
			Extended order code (n) <sup>1)</sup>	→  83
			Device name	→  83
			Manufacturer	→  84

1) n = 1, 2, 3

<b>System →</b>	<b>Information →</b>	<b>Device location →</b>	Latitude	→  84
			Longitude	→  84
			Altitude	→  84
			Location method	→  85
			Location description	→  85
			Process unit TAG	→  85

<b>System →</b>	<b>Information →</b>	<b>HART info →</b>	Device type	→  85
			Device revision	→  86
			HART revision	→  86
			HART descriptor	→  86

	HART message	→  86
	Hardware revision	→  87
	Software revision	→  87
	HART date code	→  87
	Manufacturer ID	→  87
	Device ID	→  88

<b>System</b> →	<b>Display</b> →	Display interval	→  88
		Format display	→  88
		Value 1 display	→  89
		Decimal places 1	→  89
		Value 2 display	→  89
		Decimal places 2	→  89
		Value 3 display	→  89
		Decimal places 3	→  89

## 14.1 Menu: Diagnostics

### 14.1.1 Submenu: Actual diagnostics

---

#### Actual diagnostics 1

---

<b>Navigation</b>	 Diagnostics → Actual diagnostics → Actual diagnostics 1
<b>Description</b>	Displays the current diagnostic message. If two or more messages occur simultaneously, the message with the highest priority is shown on the display.
<b>Additional information</b>	Example for display format: F041-Sensor interrupted

---

#### Operating time

---

<b>Navigation</b>	 Diagnostics → Actual diagnostics → Operating time
<b>Description</b>	Displays the length of time the device has been in operation.
<b>User interface</b>	Hours (h)

### 14.1.2 "Diagnostic list" submenu

 n = Number of diagnostic messages (n = 1 to 3)

---

#### Actual diagnostics n

---

<b>Navigation</b>	 Diagnostics → Actual diagnostics → Actual diagnostics n
<b>Description</b>	Displays the current diagnostic message. If two or more messages occur simultaneously, the message with the highest priority is shown on the display.
<b>Additional information</b>	Example for display format: F041-Sensor interrupted

---

#### Actual diag channel n

---

<b>Navigation</b>	 Diagnostics → Actual diagnostics → Actual diag channel n
<b>Description</b>	Displays the function module to which the diagnostic message refers.

---

<b>User interface</b>	<ul style="list-style-type: none"> <li>▪ Device</li> <li>▪ Sensor</li> <li>▪ Device temperature</li> <li>▪ Current output</li> <li>▪ Sensor RJ</li> </ul>
-----------------------	---

---

### Time stamp n

---

<b>Navigation</b>	 Diagnostics → Actual diagnostics → Time stamp n
<b>Description</b>	Displays the time stamp of the current diagnostic message in relation to the operating time.
<b>User interface</b>	Hours (h)

### 14.1.3 "Event logbook" submenu

 n = Number of diagnostic messages (n = 1 to 10). The last 10 messages are listed in chronological order.

---

### Previous diagnostics n

---

<b>Navigation</b>	 Diagnostics → Event logbook → Previous diagnostics n
<b>Description</b>	Displays the diagnostic messages that occurred in the past. The last 10 messages are listed in chronological order.
<b>User interface</b>	Symbol for event behavior and diagnostic event.
<b>Additional information</b>	Example for display format: F201-Electronics faulty

---

### Previous diag n channel

---

<b>Navigation</b>	 Diagnostics → Event logbook → Previous diag n channel
<b>Description</b>	Displays the function module to which the diagnostic message refers.
<b>User interface</b>	<ul style="list-style-type: none"> <li>▪ Device</li> <li>▪ Sensor</li> <li>▪ Device temperature</li> <li>▪ Current output</li> <li>▪ Sensor RJ</li> </ul>

---

**Time stamp n**

---



<b>Navigation</b>	 Diagnostics → Event logbook → Time stamp n
<b>Description</b>	Displays the time stamp of the current diagnostic message in relation to the operating time.
<b>User interface</b>	Hours (h)

### 14.1.4 "Simulation" submenu

---

**Diagnostic event simulation**



---

<b>Navigation</b>	 Diagnostics → Simulation → Diagnostic event simulation
<b>Description</b>	Switches diagnostic simulation on and off.
<b>Selection</b>	Enter one of the diagnostic events using the dropdown menu →  34. The assigned status signals and diagnostic behaviors are used in the simulation mode. Select 'Off' to quit the simulation. Example: x043 Short circuit
<b>Factory setting</b>	Off

---

**Current output simulation**

---

<b>Navigation</b>	 Diagnostics → Simulation → Current output simulation
<b>Description</b>	Use this function to switch simulation of the current output on and off. The status signal indicates a category "C" diagnostic message ("function check") while the simulation is running.
<b>Selection</b>	<ul style="list-style-type: none"> <li>■ Off</li> <li>■ On</li> </ul>
<b>Factory setting</b>	Off

---

**Value current output**

---

<b>Navigation</b>	 Diagnostics → Simulation → Value current output
-------------------	---

<b>Description</b>	Use this function to set a current value for the simulation. In this way, users can verify the correct adjustment of the current output and the correct function of downstream switching units.
<b>User entry</b>	3.58 to 23 mA
<b>Factory setting</b>	3.58 mA

---

### Sensor simulation

---

<b>Navigation</b>	 Diagnostics → Simulation → Sensor simulation
<b>Description</b>	Use this function to enable the simulation of the process variable. The simulation value of the process variable is defined in the <b>Sensor simulation value</b> parameter.
<b>Selection</b>	<ul style="list-style-type: none"> <li>■ Off</li> <li>■ On</li> </ul>
<b>Factory setting</b>	Off

---

### Sensor simulation value

---

<b>Navigation</b>	 Diagnostics → Simulation → Sensor simulation value
<b>Description</b>	Use this function to enter a simulation value for the process variable. Subsequent measured value processing and the signal output use this simulation value. In this way, users can verify whether the measuring device has been configured correctly.
<b>User entry</b>	$-1.0 \cdot 10^{20}$ to $+1.0 \cdot 10^{20}$ °C
<b>Factory setting</b>	0.00 °C

## 14.1.5 "Diagnostic settings" submenu

### Submenu: Properties

---

### Alarm delay

---

<b>Navigation</b>	 Diagnostics → Diagnostic settings → Properties → Alarm delay
<b>Description</b>	Use this function to set the delay time during which a diagnostics signal is suppressed before it is output.
<b>User entry</b>	0 to 5 s

**Factory setting** 2 s

---

### Limit corrosion detection

---

**Navigation**  Diagnostics → Diagnostic settings → Properties → Limit corrosion detection

**Prerequisite** A 4-wire RTD or TC must be selected as the sensor type or connection type. →  67

**Description** Use this function to enter the limit value for corrosion detection. If this value is exceeded, the device behaves as defined in the diagnostic settings.

**User entry** 5 to 10 000 Ω

**Factory setting**

- 50.0 Ω for 4-wire RTD connection type
- 5 000 Ω for TC connection type

---

### Sensor line resistance

---

**Navigation**  Diagnostics → Diagnostic settings → Properties → Sensor line resistance

**Prerequisite** A 4-wire RTD or TC must be selected as the sensor type or connection type. →  67

**Description** Displays the highest measured resistance value of the sensor lines.

**User interface**  $-1.0 \cdot 10^{20}$  to  $+1.0 \cdot 10^{20}$  Ω

---

### Thermocouple diagnostic

---

**Navigation**  Diagnostics → Diagnostic settings → Properties → Thermocouple diagnostic

**Description** Use this function to switch off the "Sensor corrosion" and "Sensor break" diagnostic functions during thermocouple measurement.

 This may be necessary in order to connect electronic simulators (e.g. calibrators) during a thermocouple measurement. The accuracy of the transmitter is not influenced by either the activation or deactivation of the thermocouple diagnostics function.

**Selection**



- On
- Off

**Factory setting** On

---

### Diagnostic behavior



---

<b>Navigation</b>	 Diagnostics → Diagnostic settings → Diagnostic behavior
<b>Description</b>	Each diagnostic event is assigned a certain diagnostic behavior. The user can change this assignment for certain diagnostic events. →  34
<b>Selection</b>	<ul style="list-style-type: none"> <li>■ Alarm</li> <li>■ Warning</li> <li>■ Disabled</li> </ul>
<b>Factory setting</b>	See the list of diagnostic events →  35

---

### Status signal

---

<b>Navigation</b>	 Diagnostics → Diagnostic settings → Status signal
<b>Description</b>	Each diagnostic event is assigned a certain status signal at the factory. The user can change this assignment for certain diagnostic events. →  34
<b>Selection</b>	<ul style="list-style-type: none"> <li>■ Failure (F)</li> <li>■ Function check (C)</li> <li>■ Out of specification (S)</li> <li>■ Maintenance required (M)</li> <li>■ No effect (N)</li> </ul>
<b>Factory setting</b>	See the list of diagnostic events →  34

### 14.1.6 "Min/max values" submenu

---

#### Sensor min value

---

<b>Navigation</b>	 Diagnostics → Min/max values → Sensor min value
<b>Description</b>	Displays the minimum temperature measured in the past at the sensor input (minimum indicator).

---

#### Sensor max value

---

<b>Navigation</b>	 Diagnostics → Min/max values → Sensor max value
<b>Description</b>	Displays the maximum temperature measured in the past at the sensor input (maximum indicator).

---

#### Reset sensor min/max values

---



---

<b>Navigation</b>	 Diagnostics → Min/max values → Reset sensor min/max values
<b>Description</b>	Resets the min/max values of the sensor to their default values.
<b>User entry</b>	Clicking the <b>Reset sensor min/max values</b> button activates the reset function. As a result of this action, the min/max values of the sensor only display the reset, temporary values.

---

### Device temperature min.

---

<b>Navigation</b>	 Diagnostics → Min/max values → Device temperature min.
<b>Description</b>	Displays the minimum electronics temperature measured in the past (minimum indicator).

---

### Device temperature max.

---

<b>Navigation</b>	 Diagnostics → Min/max values → Device temperature max.
<b>Description</b>	Displays the maximum electronics temperature measured in the past (maximum indicator).

---

### Reset device temp. min/max values

---

<b>Navigation</b>	 Diagnostics → Min/max values → Reset device temp. min/max values
<b>Description</b>	Resets the peakhold indicators for the minimum and maximum electronic temperatures measured.
<b>User entry</b>	Clicking the <b>Reset device temperature min/max values</b> button activates the reset function. As a result of this action, the min/max values for the device temperature only display the reset, temporary values.

## 14.2 Menu: Application

### 14.2.1 Submenu: Measured values

---

#### Sensor value

---

<b>Navigation</b>	 Application → Measured values → Sensor value
<b>Description</b>	Displays the current measured value at the sensor input.

---

**Sensor raw value**

---

**Navigation**  Application → Measured values → Sensor raw value

**Description** Displays the non-linearized mV/Ohm value at the specific sensor input.

---

**Output current**

---

**Navigation**  Application → Measured values → Output current

**Description** Displays the calculated output current in mA.

---

**Percent of range**

---

**Navigation**  Application → Measured values → Percent of range

**Description** Displays the measured value in percentage of the span

---

**Device temperature**

---

**Navigation**  Application → Measured values → Device temperature

**Description** Displays the current electronics temperature.

---

**PV**

---

**Navigation**  Application → Measured values → PV

**Description** Displays the primary device variable.

---

**SV**

---

**Navigation**  Application → Measured values → SV

**Description** Displays the secondary device variable.

---

**TV**

---

**Navigation**  Application → Measured values → TV

**Description** Displays the tertiary device variable.

---

**QV**

---

**Navigation**  Application → Measured values → QV

**Description** Displays the quaternary (fourth) device variable.

### 14.2.2 Submenu: Sensor

---

**Unit**

---

**Navigation**  Application → Sensor → Unit

**Description** Use this function to select the engineering unit for all the measured values.

**Selection**

- °C
- °F
- K
- Ω
- mV

**Factory setting** °C

**Additional information**  Please note: If another unit has been selected instead of the factory setting (°C), all the set temperature values are converted to correspond to the configured temperature unit.  
Example: 150 °C is set as the upper range value. Following the selection of °F as the engineering unit, the new (converted) upper range value = 302 °F.

---

**Sensor type**

---

**Navigation**  Application → Sensor → Sensor type

**Description** Use this function to select the sensor type for the sensor input.

 Please observe the terminal assignment when connecting the sensors. →  16

<b>Selection</b>	A list of all the possible sensor types is provided in the 'Technical data' section. →  38
<b>Factory setting</b>	Pt100 IEC751

---

### Connection type

---

<b>Navigation</b>	 Application → Sensor → Connection type
<b>Prerequisite</b>	An RTD sensor or a resistance transmitter must be specified as the sensor type.
<b>Description</b>	Use this function to select the connection type for the sensor.
<b>Selection</b>	2-wire, 3-wire, 4-wire
<b>Factory setting</b>	4-wire

---

### 2-wire compensation



---

<b>Navigation</b>	 Application → Sensor → 2-wire compensation
<b>Prerequisite</b>	An RTD sensor or a resistance transmitter with a <b>2-wire</b> connection type must be specified as the sensor type.
<b>Description</b>	Use this function to specify the resistance value for two-wire compensation in RTDs.
<b>User entry</b>	0 to 30 Ω
<b>Factory setting</b>	0 Ω

---

### Reference junction

---

<b>Navigation</b>	 Application → Sensor → Reference junction
<b>Prerequisite</b>	A thermocouple (TC) sensor must be selected as the sensor type.
<b>Description</b>	Use this function to select reference junction measurement for temperature compensation of thermocouples (TC).  If <b>Preset value</b> is selected, the compensation value is specified via the <b>RJ preset value</b> parameter.
<b>Selection</b>	<ul style="list-style-type: none"> <li>■ Internal measurement: the internal reference junction temperature is used.</li> <li>■ Fixed value: a fixed value is used.</li> <li>■ Measured value of external sensor: The measured value of an RTD Pt100 2-wire sensor which is connected to terminals 4 and 6 is used.</li> </ul>

---

**Factory setting**                      Internal measurement

---

### RJ preset value

---

**Navigation**                                  Application → Sensor → RJ preset value

**Prerequisite**                            The **Preset value** parameter must be set if the **Reference junction** option is selected.

**Description**                             Use this function to define the fixed preset value for temperature compensation.

**User entry**                                -58 to +360

**Factory setting**                         0,00

---

### Sensor offset

---

**Navigation**                                  Application → Sensor → Sensor offset

**Description**                             Use this function to set the zero point correction (offset) of the sensor measured value. The value indicated is added to the measured value.

**User entry**                                -18.0 to +18.0

**Factory setting**                         0,0

## 14.2.3 Submenu: Linearization

---

### Call./v. Dusen coeff. R0

---

**Navigation**                                  Application → Sensor → Linearization → Call./v. Dusen coeff. R0

**Prerequisite**                            The RTD platinum (Callendar/Van Dusen) option is enabled in the **Sensor type** parameter.

**Description**                             Use this function to set the R0 Value only for linearization with the Callendar/Van Dusen polynomial.

**User entry**                                10 to 2 000 Ω

**Factory setting**                         100.000 Ω

---

### Call./v. Dusen coeff. A, B and C

---

<b>Navigation</b>	 Application → Sensor → Linearization → Call./v. Dusen coeff. A, B and C
<b>Prerequisite</b>	The RTD platinum (Callendar/Van Dusen) option is enabled in the <b>Sensor type</b> parameter.
<b>Description</b>	Use this function to set the coefficients for sensor linearization based on the Callendar/Van Dusen method.
<b>User entry</b>	<ul style="list-style-type: none"> <li>■ A: 3.0e-003 to 4.0e-003</li> <li>■ B: -2.0e-006 to 2.0e-006</li> <li>■ C: -1.0e-009 to 1.0e-009</li> </ul>
<b>Factory setting</b>	<ul style="list-style-type: none"> <li>■ A: 3.90830e-003</li> <li>■ B: -5.77500e-007</li> <li>■ C: -4.18300e-012</li> </ul>

---

**Polynomial coeff. R0**



---

<b>Navigation</b>	 Application → Sensor → Linearization → Polynomial coeff. R0
<b>Prerequisite</b>	The RTD poly nickel or RTD copper polynomial option is enabled in the <b>Sensor type</b> parameter.
<b>Description</b>	Use this function to set the R0 Value only for linearization of nickel/copper sensors.
<b>User entry</b>	10 to 2 000 Ω
<b>Factory setting</b>	100.00 Ω

---

**Polynomial coeff. A, B**



---

<b>Navigation</b>	 Application → Sensor → Linearization → Polynomial coeff. Polynomial coeff. A, B
<b>Prerequisite</b>	The RTD poly nickel or RTD copper polynomial option is enabled in the <b>Sensor type</b> parameter.
<b>Description</b>	Use this function to set the coefficients for sensor linearization of copper/nickel resistance thermometers.
<b>User entry</b>	<ul style="list-style-type: none"> <li>■ Polynomial coeff. A: 4.0e-003 to 6.0e-003</li> <li>■ Polynomial coeff. B: -2.0e-005 to 2.0e-005</li> </ul>
<b>Factory setting</b>	Polynomial coeff. A = 5.49630e-003 Polynomial coeff. B = 6.75560e-006

---

**Sensor lower limit**



---

<b>Navigation</b>	 Application → Sensor → Linearization → Sensor lower limit
<b>Prerequisite</b>	The RTD platinum, RTD poly nickel or RTD copper polynomial option is enabled in the <b>Sensor type</b> parameter.
<b>Description</b>	Use this function to set the lower calculation limit for special sensor linearization.
<b>User entry</b>	Depends on the <b>sensor type</b> selected.
<b>Factory setting</b>	Depends on the <b>sensor type</b> selected.

---

### Sensor upper limit

---

<b>Navigation</b>	 Application → Sensor → Linearization → Sensor upper limit
<b>Prerequisite</b>	The RTD platinum, RTD poly nickel or RTD copper polynomial option is enabled in the <b>Sensor type</b> parameter.
<b>Description</b>	Use this function to set the upper calculation limit for special sensor linearization.
<b>User entry</b>	Depends on the <b>sensor type</b> selected.
<b>Factory setting</b>	Depends on the <b>sensor type</b> selected.

## 14.2.4 Submenu: Current output

---

### 4mA value

---

<b>Navigation</b>	 Application → Current output → 4mA value
<b>Description</b>	Use this function to assign a measured value to the current value 4 mA.
<b>Factory setting</b>	0 °C

---

### 20mA value

---

<b>Navigation</b>	 Application → Current output → 20mA value
<b>Description</b>	Use this function to assign a measured value to the current value 20 mA.
<b>Factory setting</b>	100 °C

**Failure mode**

<b>Navigation</b>	 Application → Current output → Failure mode
<b>Description</b>	Use this function to select the signal on alarm level of the current output in the event of an error.
<b>Selection</b>	<ul style="list-style-type: none"> <li>■ High alarm</li> <li>■ Low alarm</li> </ul>
<b>Factory setting</b>	Low alarm

**Failure current**

<b>Navigation</b>	 Application → Current output → Failure current
<b>Prerequisite</b>	The <b>High alarm</b> option is enabled in the "Failure mode" parameter.
<b>Description</b>	Use this function to set the value the current output adopts in an alarm condition.
<b>User entry</b>	21.5 to 23 mA
<b>Factory setting</b>	22.5 mA

**Adjustment of the analog output (4 and 20 mA current trimming)**

Current trimming is used to compensate the analog output (D/A conversion). Here, the output current of the transmitter can be adapted so that it suits the value expected at the higher-level system.

 Current trimming does not affect the digital HART value. This can cause the measured value shown on the locally installed display to differ marginally from the value displayed in the higher-level system.

*Procedure*

1. Start
↓
2. Install an accurate ammeter (more accurate than the transmitter) in the current loop.
↓
3. Switch on current output simulation and set the simulation value to 4 mA.
↓
4. Measure the loop current with the ammeter and make a note of the value.
↓
5. Set the simulation value to 20 mA.
↓
6. Measure the loop current with the ammeter and make a note of the value.
↓
7. Enter the current values determined as adjustment values in the <b>Current trimming 4 mA / 20 mA</b> parameters



↓
8. Deactivate simulation
↓
9. End

---

### Current trimming 4 mA

---

<b>Navigation</b>	 Application → Current output → Current trimming 4 mA
<b>Description</b>	Use this function to set the correction value for the current output at the start of the measuring range at 4 mA.
<b>User entry</b>	3.85 to 4.15 mA
<b>Factory setting</b>	4 mA
<b>Additional information</b>	The trimming only affects the current loop values from 3.8 to 20.5 mA. The failure mode with <b>Low Alarm</b> and <b>High Alarm</b> current values is not subject to trimming.

---

### Current trimming 20 mA

---

<b>Navigation</b>	 Application → Current output → Current trimming 20 mA
<b>Description</b>	Use this function to set the correction value for the current output at the end of the measuring range at 20 mA.
<b>User entry</b>	19.85 to 20.15 mA
<b>Factory setting</b>	20.000 mA
<b>Additional information</b>	The trimming only affects the current loop values from 3.8 to 20.5 mA. The failure mode with <b>Low Alarm</b> and <b>High Alarm</b> current values is not subject to trimming.

---

### Damping

---

<b>Navigation</b>	 Application → Current output → Damping
<b>Description</b>	Use this function to set the time constant for current output damping.
<b>User entry</b>	0 to 120 s
<b>Factory setting</b>	0 s

<b>Additional information</b>	The current output responds to fluctuations in the measured value with an exponential delay. The time constant of this delay is defined by this parameter. If a low time constant is entered, the current output responds quickly to the measured value. On the other hand, the response of the current output is delayed significantly if a high time constant is entered.
-------------------------------	---

### 14.2.5 Submenu: HART configuration

---

#### Assign current output (PV)

---

<b>Navigation</b>	 Application → HART configuration → Assign current output (PV)
<b>Description</b>	Use this function to assign the measured variables to the primary HART value (PV).
<b>User interface</b>	Sensor
<b>Factory setting</b>	Sensor (fixed assignment)

---

#### Assign SV

---

<b>Navigation</b>	 Application → HART configuration → Assign SV
<b>Description</b>	Use this function to assign the measured variable to the secondary HART value (SV).
<b>User interface</b>	Device temperature (fixed assignment)
<b>Factory setting</b>	Device temperature (fixed assignment)

---

#### Assign TV

---

<b>Navigation</b>	 Application → HART configuration → Assign TV
<b>Description</b>	Use this function to assign the measured variable to the tertiary HART value (TV).
<b>User interface</b>	Sensor (fixed assignment)
<b>Factory setting</b>	Sensor (fixed assignment)

---

#### Assign QV

---



<b>Navigation</b>	 Application → HART configuration → Assign QV
-------------------	--

<b>Description</b>	Use this function to assign the measured variable to the quaternary (fourth) HART value (QV).
<b>User interface</b>	Sensor (fixed assignment)
<b>Factory setting</b>	Sensor (fixed assignment)

---

## HART address

---

<b>Navigation</b>	 Application → HART configuration → HART address
<b>Description</b>	Use this function to define the HART address of the device.  It is not possible to write to the parameter. The HART address can be set in FDT/DTM-based operating tools, via the CommDTM. <sup>1)</sup>
	1) It cannot be set via the Configuration app, however.
<b>Factory setting</b>	0
<b>Additional information</b>	The measured value can only be transmitted via the current value if the address is set to "0". The current is fixed at 4.0 mA for all other addresses (Multidrop mode).

---

## No. of preambles

---

<b>Navigation</b>	 Application → HART configuration → No. of preambles
<b>Description</b>	Use this function to define the number of preambles in the HART telegram.
<b>User entry</b>	5 to 20
<b>Factory setting</b>	5

## 14.3 Menu: System

### 14.3.1 Submenu: Device management

---

## HART short tag

---

<b>Navigation</b>	 System → Device management → HART short tag
<b>Description</b>	Use this function to define a short tag for the measuring point.
<b>User entry</b>	Up to 8 alphanumeric characters (letters, numbers and special characters).

---

**Factory setting**                    8 x '?'

---

### Device tag

---

**Navigation**                     System → Device management → Device tag

**Description**                    Use this function to enter a unique name for the measuring point so it can be identified quickly within the plant.

**User entry**                    Max. 32 characters, such as letters, numbers or special characters (e.g. @, %, /)

**Factory setting**                Depends on the product root and serial number

---

### Mains filter

---

**Navigation**                     System → Device management → Mains filter

**Description**                    Use this function to select the mains filter for A/D conversion.

**Selection**

- 50 Hz
- 60 Hz

**Factory setting**                50 Hz

---

### Locking status

---

**Navigation**                     System → Device management → Locking status

**Description**                    Displays the device locking status. When write protection is activated, write access to the parameters is disabled.

**User interface**                Enabled or disabled check box: **Locked by hardware**

---

### Device reset

---

**Navigation**                     System → Device management → Device reset



**Description**                    Use this function to reset the device configuration - either entirely or in part - to a defined state.

<b>Selection</b>	<ul style="list-style-type: none"> <li>▪ <b>Not active</b> No action is executed and the user exits the parameter.</li> <li>▪ <b>To factory defaults</b> All the parameters are reset to the factory setting.</li> <li>▪ <b>To delivery settings</b> All the parameters are reset to the order configuration. The order configuration can differ from the factory setting if customer-specific parameter values were defined when the device was ordered.</li> <li>▪ <b>Restart device</b> The device is restarted but the device configuration remains unchanged.</li> </ul>
<b>Factory setting</b>	Not active

---

### Configuration counter

---

<b>Navigation</b>	 System → Device management → Configuration counter
<b>Description</b>	<p>Displays the counter reading for changes to device parameters.</p> <p> Static parameters, whose values change during optimization or configuration, cause this parameter to increase by 1. This supports parameter version management. If several parameters change, e. g. due to loading of parameters from the operating software etc. in the device, the counter can show a higher value. The counter cannot be reset and is also not reset to the default value when the device is reset. If the counter overflows, (16 bit), it starts again at 1.</p>

---

### Configuration changed

---

<b>Navigation</b>	 System → Device management → Configuration changed
<b>Description</b>	Displays whether the configuration of the device has been changed by a master (primary or secondary).

---

### Reset configuration changed flag

---

<b>Navigation</b>	 System → Device management → Reset configuration changed flag
<b>Description</b>	The <b>Configuration changed</b> information is reset by a master (primary or secondary).

## 14.3.2 User management submenu

Define password → Maintenance	New password
	Confirm new password
	Status password entry

<b>Change user role</b> → Operator	Password <sup>1)</sup>
	Status password entry
<b>Reset password</b> → Operator	Reset password
	Status password entry
<b>Change password</b> → Maintenance	Old password
	New password
	Confirm new password
	Status password entry
<b>Delete password</b> → Maintenance	Delete password

1) The required user role must be selected here when operating the device via the Configuration app.

Navigation in the submenu is supported by the following operating elements:

- **Back**  
Return to the previous page
- **Cancel**  
If Cancel is selected, the status before the submenu was started is restored

---

### Define password



---

<b>Navigation</b>	 System → User management → Define password
<b>Description</b>	Use this function to start password definition
<b>User entry</b>	Activate the button

---

### New password

---

<b>Navigation</b>	 System → User management → Define password → New password
<b>Description</b>	Use this function to enter a password for the <b>Maintenance</b> user role to gain access to the relevant functions.
<b>Additional information</b>	<p>If the factory setting is not changed, the device is set to the <b>Maintenance</b> user role. This means that the device's configuration data are not write-protected and can be edited at all times.</p> <p>Once a password has been defined, devices can be switched to the <b>Maintenance</b> user role if the correct password is entered in the <b>Password</b> parameter. A new password becomes valid once it has been verified after being entered in the <b>Confirm new password</b> parameter.</p> <p> The password must contain a minimum of 4 and a maximum of 16 characters and can consist of both letters and numbers. Leading and trailing spaces not used as part of the password. If you lose your password, please contact your supplier.</p>
<b>User entry</b>	..... (enter the password)

---

**Confirm new password**



---

<b>Navigation</b>	 System → User management → Define password → Confirm new password
<b>Description</b>	Use this function to confirm the new password that has been defined.
<b>Additional information</b>	A new password becomes valid once it has been verified after being entered in the <b>Confirm new password</b> parameter. The password must contain a minimum of 4 and a maximum of 16 characters and can consist of both letters and numbers. If you lose your password, please contact your supplier.
<b>User entry</b>	..... (enter the password)

---

**Status password entry**



---

<b>Navigation</b>	 System → User management → Define password → Status password entry
<b>Description</b>	Displays the status of the password verification. <ul style="list-style-type: none"> <li>■ Password accepted</li> <li>■ Wrong password</li> <li>■ Password rules violated</li> <li>■ Permission denied</li> <li>■ Incorrect input sequence</li> <li>■ Invalid user role</li> <li>■ Confirm PW mismatch</li> <li>■ Reset password accepted</li> </ul>

---

**Enter password**

---

<b>Navigation</b>	 System → User management → Enter password
<b>Prerequisite</b>	The <b>Operator</b> user role is active and a password has been defined.
<b>Description</b>	Use this function to enter a password for the selected user role to gain access to the functions of this role.
<b>User entry</b>	Enter the defined password.

---

**Status password entry**

---

<b>Navigation</b>	 System → User management → Enter password → Status password entry
-------------------	---

**Description** →  79

---

## Reset password

---

**Navigation**  System → User management → Reset password

**Prerequisite** The **Operator** user role is active and a password has already been defined.

**Description** Use this function to enter the reset code to reset the current password.

**⚠ CAUTION**

**Current password is lost.**

▶ Only use the reset code if you have lost the current password. Contact supplier.

**User entry** Activate the text box and enter the reset code.

---

## Status password entry

---

**Navigation**  System → User management → Reset password → Status password entry

**Description** →  79

---

## Logout

---

**Navigation**  System → User management → Logout

**Prerequisite** The **Maintenance** user role must be active.

**Description** The **Maintenance** user role is exited and the system switches to the **Operator** user role.

**User entry** Activate the button.

---



## Change password

---

**Navigation**  System → User management → Change password

**Prerequisite** The **Maintenance** user role must be active.





<b>Description</b>	<ul style="list-style-type: none"> <li>▪ Old password: Use this function to enter the current password to then be able to make changes to the existing password.</li> <li>▪ New password: →  77</li> <li>▪ Confirm new password: →  77</li> </ul>
<b>User entry</b>	<ul style="list-style-type: none"> <li>▪ ..... (enter the old password)</li> <li>▪ ..... (enter the new password)</li> <li>▪ ..... (confirm the new password)</li> </ul>

---

### Status password entry

---

<b>Navigation</b>	 System → User management → Change password → Status password entry
<b>Description</b>	→  79

---

### Delete password

---



<b>Navigation</b>	 System → User management → Delete password
<b>Prerequisite</b>	The <b>Maintenance</b> user role must be active.
<b>Description</b>	The password currently valid is deleted. The <b>Define password</b> button appears.
<b>User entry</b>	Activate the <b>Delete password</b> button.

## 14.3.3 Bluetooth configuration submenu

---

### Bluetooth

---

<b>Navigation</b>	 System → Bluetooth configuration → Bluetooth
<b>Description</b>	Use this function to enable or disable the Bluetooth function. <ul style="list-style-type: none"> <li>▪ Off: The Bluetooth interface is disabled immediately.</li> <li>▪ On: The Bluetooth interface is enabled and a connection to the device can be established.</li> </ul>  Bluetooth communication is only possible if the CDI and display interface is not used.
<b>Selection</b>	<ul style="list-style-type: none"> <li>▪ Off</li> <li>▪ On</li> </ul>
<b>Factory setting</b>	On

---

### Change Bluetooth password <sup>1)</sup>

---

1) Function is only visible in the Configuration app

<b>Navigation</b>	 System → Bluetooth configuration → Change Bluetooth password
<b>Description</b>	Use this function to change the Bluetooth password. This function is visible in the Configuration app only.
<b>Prerequisite</b>	The Bluetooth interface is enabled (ON) and a connection to the device is established.
<b>User entry</b>	Enter: <ul style="list-style-type: none"> <li>▪ User name</li> <li>▪ Current password</li> <li>▪ New password</li> <li>▪ Confirm new password</li> </ul> Press OK to confirm your entries.

## 14.3.4 Information submenu

### Device submenu

---

### Squawk

---

<b>Navigation</b>	 System → Information → Device → Squawk
<b>Description</b>	This function can be used locally to facilitate the identification of the device in the field. Once the Squawk function has been activated, all the segments flash on the display.
<b>Selection</b>	<ul style="list-style-type: none"> <li>▪ <b>Squawk once:</b> Display of device flashes for 60 seconds and then returns to normal operation.</li> <li>▪ <b>Squawk on:</b> Display of device flashes continuously.</li> <li>▪ <b>Squawk off:</b> Squawk is switched off and the display returns to normal operation.</li> </ul>
<b>User entry</b>	Activate the relevant button

---

### Serial number

---

<b>Navigation</b>	 System → Information → Device → Serial number
<b>Description</b>	Displays the serial number of the device. It can also be found on the nameplate.
<b>User interface</b>	Max. 11-digit character string comprising letters and numbers.

---

**Order code**

---

**Navigation**
 System → Information → Device → Order code
**Description**

Displays the order code of the device. It can also be found on the nameplate. The order code is generated from the extended order code, which defines all the device features of the product structure. In contrast, the device features cannot be read directly from the order code.

---

**Firmware version**

---

**Navigation**
 System → Information → Device → Firmware version
**Description**

Displays the device firmware version that is installed.

**User interface**

Max. 6-digit character string in the format xx.yy.zz

---

**Hardware revision**

---



**Navigation**
 System → Information → Device → Hardware revision
**Description**

Displays the hardware revision of the device.

---

**Extended order code (n)**

---

 n = Number of parts of the extended order code (n = 1 to 3)
**Navigation**
 System → Information → Device → Extended order code n
**Description**

Displays the first, second and/or third part of the extended order code. On account of length restrictions, the extended order code is split into a maximum of 3 parameters. The extended order code indicates the version of all the features of the product structure for the device and thus uniquely identifies the device. It can also be found on the nameplate.

- Uses of the extended order code
- To order an identical spare device.
- To check the ordered device features using the delivery note.

---

**Device name**

---

---

<b>Navigation</b>	 System → Information → Device → Device name
<b>Description</b>	Displays the device name. It can also be found on the nameplate.

---

### Manufacturer

---

<b>Navigation</b>	 System → Information → Device → Manufacturer
<b>Description</b>	Displays the name of the manufacturer.

### Device location submenu

---

### Latitude

---

<b>Navigation</b>	 System → Information → Device location → Latitude
<b>Description</b>	Use this function to enter the latitude coordinates that describe the device location.
<b>User entry</b>	-90.000 to +90.000 °
<b>Factory setting</b>	0

---

### Longitude

---

<b>Navigation</b>	 System → Information → Device location → Longitude
<b>Description</b>	Use this function to enter the longitude coordinates that describe the device location.
<b>User entry</b>	-180.000 to +180.000 °
<b>Factory setting</b>	0

---

### Altitude

---

<b>Navigation</b>	 System → Information → Device location → Altitude
<b>Description</b>	Use this function to enter the altitude data that describe the device location.
<b>User entry</b>	$-1.0 \cdot 10^{+20}$ to $+1.0 \cdot 10^{+20}$ m
<b>Factory setting</b>	0 m

---

**Location method**



---

<b>Navigation</b>	 System → Information → Device location → Location method
<b>Description</b>	Use this function to select the data format for specifying the geographic location. The codes for specifying the location are based on the US National Marine Electronics Association (NMEA) Standard NMEA 0183.
<b>Selection</b>	<ul style="list-style-type: none"> <li>■ No fix</li> <li>■ GPS or Standard Positioning Service (SPS) fix</li> <li>■ Differential PGS fix</li> <li>■ Precise positioning service (PPS)</li> <li>■ Real Time Kinetic (RTK) fixed solution</li> <li>■ Real Time Kinetic (RTK) float solution</li> <li>■ Estimated dead reckoning</li> <li>■ Manual input mode</li> <li>■ Simulation mode</li> </ul>
<b>Factory setting</b>	Manual input mode

---

**Location description**



---

<b>Navigation</b>	 System → Information → Device location → Location description
<b>Description</b>	Use this function to enter a description of the location so that the device can be located in the plant.
<b>User entry</b>	Up to 32 alphanumeric characters (letters, numbers and special characters)
<b>Factory setting</b>	32 x '?'

---

**Process unit tag**

---

<b>Navigation</b>	 System → Information → Device location → Process unit tag
<b>Description</b>	Use this function to enter the process unit in which the device is installed.
<b>User entry</b>	Up to 32 alphanumeric characters (letters, numbers and special characters)
<b>Factory setting</b>	32 x '?'

**HART info submenu**

---

**Device type**

---

---

<b>Navigation</b>	 System → Information → HART info → Device type
<b>Description</b>	Displays the device type with which the device is registered with the HART FieldComm Group. The device type is specified by the manufacturer. It is needed to assign the appropriate device description file (DD) to the device.
<b>User interface</b>	4-digit hexadecimal number
<b>Factory setting</b>	0x11D0

---

#### Device revision

---

<b>Navigation</b>	 System → Information → HART info → Device revision
<b>Description</b>	Displays the device revision with which the device is registered with the HART FieldComm Group. It is needed to assign the appropriate device description file (DD) to the device.
<b>User interface</b>	Revision in hexadecimal format
<b>Factory setting</b>	0x01

---

#### HART revision

---

<b>Navigation</b>	 System → Information → HART info → HART revision
<b>Description</b>	Displays the HART revision of the device

---

#### HART descriptor

---

<b>Navigation</b>	 System → Information → HART info → HART descriptor
<b>Description</b>	Use this function to define a description for the measuring point.
<b>User entry</b>	Up to 16 alphanumeric characters (uppercase letters, numbers and special characters)
<b>Factory setting</b>	16 x '?'

---

#### HART message

---

<b>Navigation</b>	 System → Information → HART info → HART message
-------------------	---

---

<b>Description</b>	Use this function to define a HART message which is sent via the HART protocol when requested by the master.
<b>User entry</b>	Up to 32 alphanumeric characters (uppercase letters, numbers and special characters)
<b>Factory setting</b>	32 x '?'

---

#### Hardware revision → 83

---

<b>Navigation</b>	 System → Information → HART info → Hardware revision
-------------------	--

---

#### Software revision

---

<b>Navigation</b>	 System → Information → HART info → Software revision
<b>Description</b>	Displays the software revision of the device.

---

#### HART date code

---

<b>Navigation</b>	 System → Information → HART info → HART date code
<b>Description</b>	Use this function to define date information for individual use.
<b>User entry</b>	Date in the format year-month-day (YYYY-MM-DD)
<b>Factory setting</b>	2010-01-01 <sup>1)</sup>

1) Also 01.01.2010 depending on the operating tool

---

#### Manufacturer ID

---

<b>Navigation</b>	 System → Information → HART info → Manufacturer ID
<b>Description</b>	Displays the manufacturer ID with which the device is registered with the HART FieldComm Group.
<b>User interface</b>	4-digit hexadecimal number
<b>Factory setting</b>	0x0011

---

**Device ID**

---



<b>Navigation</b>	 System → Information → HART info → Device ID
<b>Description</b>	A unique HART identifier is saved in the device ID and used by the control systems to identify the device. The device ID is also transmitted in command 0. The device ID is determined unambiguously from the serial number of the device.
<b>User interface</b>	ID generated for specific serial number

### 14.3.5 Submenu: Display

---

**Display interval**



---

<b>Navigation</b>	 System → Display → Display interval
<b>Description</b>	Set the display duration of the measured values on the local display if they are displayed in alternation. This type of change is only generated automatically if several measured values are specified. <ul style="list-style-type: none"> <li> The <b>Value 1 display - Value 3 display</b> parameters are used to specify which measured values are shown on the local display.</li> <li>The display format of the displayed measured values is specified using the <b>Format display</b> parameter.</li> </ul>
<b>User entry</b>	4 to 20 s
<b>Factory setting</b>	4 s

---

**Format display**



---

<b>Navigation</b>	 System → Display → Format display
<b>Description</b>	Use this function to select how the measured value is shown on the local display. The display format <b>Measured value</b> or <b>Measured value with bar graph</b> can be configured.
<b>Selection</b>	<ul style="list-style-type: none"> <li>▪ Value</li> <li>▪ Value + bar graph</li> </ul>
<b>Factory setting</b>	Value

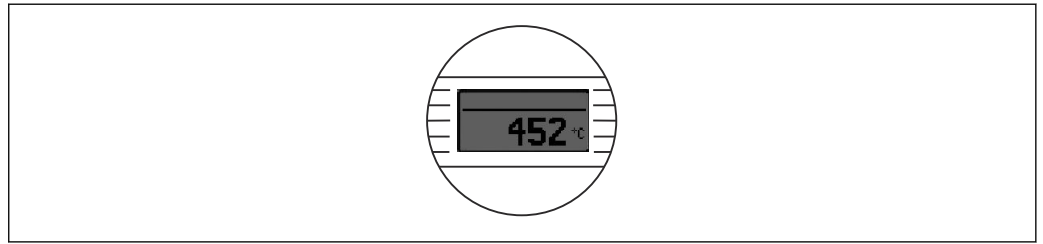

**Additional information***Value*

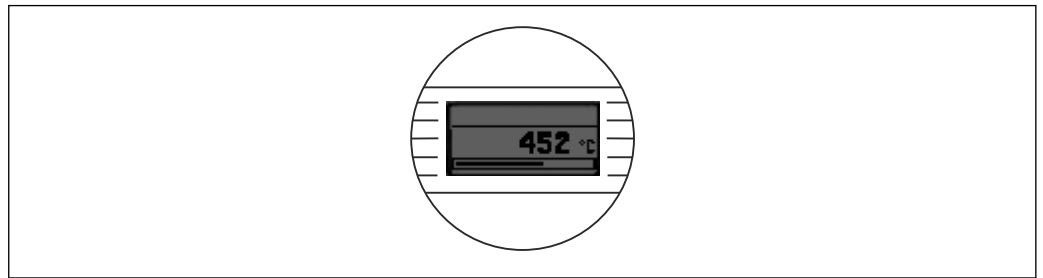
A0014564

*Value + bar graph*

A0014563

**Value 1 display** (Value 2 or 3 display)**Navigation**
 System → Display → Format display → Value 1 display (Value 2 or 3 display)
**Description**

Use this function to select a measured value that is shown on the local display.

 The **Format display** parameter is used to specify how the measured values are displayed.

**Selection**

- Process value
- Device temperature
- Output current
- Percent of range
- Off

**Factory setting**

Process value

**Decimal places 1** (decimal places 2 or 3)**Navigation**
 System → Display → Format display → Decimal places 1 (Decimal places 2 or 3)
**Prerequisite**

A measured value is defined in the parameter **Value 1 display** (Value 2 or 3 display).

**Description**

Use this function to select the number of decimal places for the display value. This setting does not affect the accuracy of the device for measuring or calculating the value.

 If **Automatic** is selected, the maximum possible number of decimal places is always shown on the display.

**Selection**

- x
- x.x
- x.xx
- x.xxx
- x.xxxx
- Automatic

**Factory setting**

Automatic

# Index

## 0 ... 9

2-wire compensation (parameter) . . . . .	68
4mA value (parameter) . . . . .	71
20mA value (parameter) . . . . .	71

## A

Actual diag channel n . . . . .	59
Actual diagnostics (submenu) . . . . .	59
Actual diagnostics 1 . . . . .	59
Actual diagnostics n . . . . .	59
Alarm delay (parameter) . . . . .	62
Altitude (parameter) . . . . .	84
Assign current output (PV) (parameter) . . . . .	74
Assign QV (parameter) . . . . .	74
Assign SV (parameter) . . . . .	74
Assign TV (parameter) . . . . .	74

## B

Bluetooth (parameter) . . . . .	81
Bluetooth configuration (submenu) . . . . .	81

## C

Call./v. Dusen coeff. A, B and C (parameter) . . . . .	69
Call./v. Dusen coeff. R0 (parameter) . . . . .	69
CE mark . . . . .	7
Change Bluetooth password (parameter) . . . . .	82
Change password (parameter) . . . . .	80
Configuration changed (parameter) . . . . .	77
Configuration counter (parameter) . . . . .	77
Confirm new password (parameter) . . . . .	79
Connection type (parameter) . . . . .	68
Current output (submenu) . . . . .	71
Current output simulation (parameter) . . . . .	61
Current trimming 4 mA (parameter) . . . . .	73
Current trimming 20 mA (parameter) . . . . .	73

## D

Damping (parameter) . . . . .	73
Decimal point (parameter) . . . . .	89
Declaration of Conformity . . . . .	7
Define password (parameter) . . . . .	78
Delete password (parameter) . . . . .	81
Device (submenu) . . . . .	82
Device ID . . . . .	88
Device location (submenu) . . . . .	84
Device management (submenu) . . . . .	75
Device name . . . . .	83
Device reset (parameter) . . . . .	76
Device revision . . . . .	86
Device tag (parameter) . . . . .	76
Device temperature . . . . .	66
Device temperature max. (parameter) . . . . .	65
Device temperature min. (parameter) . . . . .	65
Device type . . . . .	85
Device variables . . . . .	27
Diagnostic behavior (parameter) . . . . .	63
Diagnostic event simulation (parameter) . . . . .	61

## Diagnostic events

Diagnostic behavior . . . . .	34
Overview . . . . .	34
Status signals . . . . .	34
Diagnostic list (submenu) . . . . .	59
Diagnostic settings (submenu) . . . . .	62
Display (submenu) . . . . .	88
Display interval (parameter) . . . . .	88
Disposal . . . . .	37
Document	
Function . . . . .	4
Document function . . . . .	4

## E

Enter password (parameter) . . . . .	79
Event logbook (submenu) . . . . .	60

## F

Failure current (parameter) . . . . .	72
Failure mode (parameter) . . . . .	72
Firmware version . . . . .	83
Format display (parameter) . . . . .	88

## H

Hardware revision . . . . .	83, 87
HART address (parameter) . . . . .	75
HART configuration (submenu) . . . . .	74
HART date code (parameter) . . . . .	87
HART descriptor (parameter) . . . . .	86
HART info (submenu) . . . . .	85
HART message (parameter) . . . . .	86
HART revision . . . . .	86
HART short tag (parameter) . . . . .	75

## I

Information (submenu) . . . . .	82
Installation point	
DIN rail (DIN rail clip) . . . . .	9
Field housing . . . . .	9
Terminal head, flat face as per DIN 43729 . . . . .	9
Intended use . . . . .	6

## L

Latitude (parameter) . . . . .	84
Limit corrosion detection (parameter) . . . . .	63
Linearization (submenu) . . . . .	69
Location description (parameter) . . . . .	85
Location method (parameter) . . . . .	85
Locking status . . . . .	76
Logout (parameter) . . . . .	80
Longitude (parameter) . . . . .	84

## M

Mains filter (parameter) . . . . .	76
Manufacturer (parameter) . . . . .	84
Manufacturer ID (parameter) . . . . .	87
Measured values (submenu) . . . . .	65

Min/max values (submenu) . . . . .	64	SV . . . . .	66
<b>N</b>		System (menu) . . . . .	59, 65, 75
New password (parameter) . . . . .	78	<b>T</b>	
No. of preambles (parameter) . . . . .	75	Terminal assignment . . . . .	16
<b>O</b>		Thermocouple diagnostic (parameter) . . . . .	63
Operating time . . . . .	59	Time stamp n . . . . .	60, 61
Operation options		Troubleshooting	
On-site operation . . . . .	20	Application error with TC sensor connection . . . . .	32
Operating tool . . . . .	20	Application errors RTD sensor connection . . . . .	32
Overview . . . . .	20	Checking the display . . . . .	31
Wireless Field Device Configurator app . . . . .	26	General errors . . . . .	31
Order code . . . . .	83	TV . . . . .	67
Order code (parameter) . . . . .	83	<b>U</b>	
Output current . . . . .	66	Unit (parameter) . . . . .	67
<b>P</b>		User management (submenu) . . . . .	77
Percent of range . . . . .	66	<b>V</b>	
Polynomial coeff. A, B (parameter) . . . . .	70	Value current output (parameter) . . . . .	61
Polynomial coeff. RO (parameter) . . . . .	70	Value display (parameter) . . . . .	89
Previous diag n channel . . . . .	60	Version data for the device . . . . .	27
Previous diagnostics . . . . .	60	<b>W</b>	
Process unit tag (parameter) . . . . .	85	Wire without wire end ferrule . . . . .	17
Product safety . . . . .	7	Workplace safety . . . . .	6
Properties (submenu) . . . . .	62		
PV . . . . .	66		
<b>Q</b>			
QV . . . . .	67		
<b>R</b>			
Reference junction (parameter) . . . . .	68		
Reset configuration Changed flag (parameter) . . . . .	77		
Reset device temp. min/max values (parameter) . . . . .	65		
Reset password (parameter) . . . . .	80		
Reset sensor min/max values (parameter) . . . . .	64		
RJ preset value (parameter) . . . . .	69		
<b>S</b>			
Sensor (submenu) . . . . .	67		
Sensor line resistance (parameter) . . . . .	63		
Sensor lower limit (parameter) . . . . .	70		
Sensor max value (parameter) . . . . .	64		
Sensor min value (parameter) . . . . .	64		
Sensor offset (parameter) . . . . .	69		
Sensor raw value . . . . .	66		
Sensor simulation (parameter) . . . . .	62		
Sensor simulation value (parameter) . . . . .	62		
Sensor type (parameter) . . . . .	67		
Sensor upper limit (parameter) . . . . .	71		
Sensor value . . . . .	65		
Serial number . . . . .	82		
Simulation (submenu) . . . . .	61		
Software revision . . . . .	87		
Solid wire . . . . .	17		
Squawk (Assistant) . . . . .	82		
Status password entry (parameter) . . . . .	79, 80, 81		
Status signal (parameter) . . . . .	64		
Structure of the operating menu . . . . .	23		









71683049