

FLAWSIC600-XT

Custody transfer natural gas measurement with intelligent diagnostic functions

The perfect match

- Low measurement uncertainty in every application
- High measurement data reliability and availability
- The right ultrasonic gas flowmeter for every application – without compromise
- Simple device integration – even in compact systems
- Quick and easy commissioning and checking
- Cost-effective quantification of the H₂ content in natural gas



FLAWSIC600-XT: The perfect match

As the market leader for reliable and highly precise ultrasonic gas flow measuring instruments, the question we have to ask ourselves is this: How can we get even stronger? And the answer is actually rather simple – the way for us to improve is to listen attentively to the individual requirements of the people that use our products and adapt them accordingly.

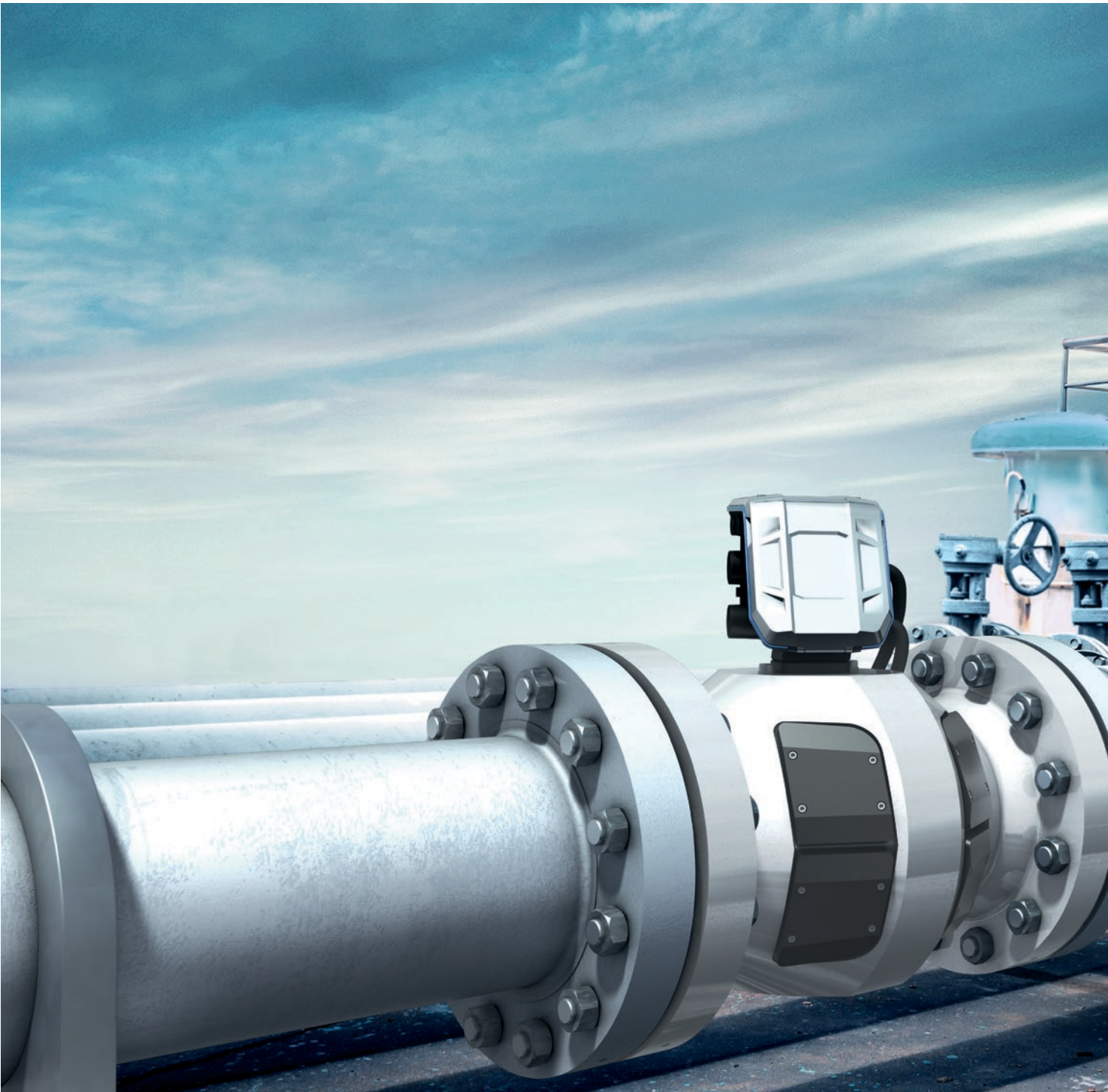

With four device versions available, FLOWSIC600-XT can take on any challenge – whether it is being used as a stand-alone or system solution – and delivers best measurement performance. Its trend-setting design houses some impressive and innovative internal features: i-diagnostics™ for smart application diagnostics with a built-in solution

wizard, and PowerIn Technology™, which continues to take measurements for up to three weeks in the event of a mains voltage failure. FLOWSIC600-XT features an ideal combination of maximum measurement accuracy, long-term stability, and unparalleled operational safety, yet is not at all complicated to use.



Measurement data reliability and availability

FLAWSIC600 flow measurement technology already provided absolute long-term stability in extreme ambient conditions, and now FLOWSIC600-XT combines the features of its predecessor with unprecedented usability. Throughout its entire service life, it meets every requirement for safe, stable, and custody transfer gas quantity measurement. Measurement and diagnostics data as well as status changes can be recorded permanently in six accessible data archives. FLOWSIC600-XT further ensures that measurements continue to be taken and data is stored even in the event of a mains voltage failure, thanks to PowerIn Technology™.

Simple device integration – even in compact systems

We are constantly further developing the ultrasonic technology. FLOWSIC600-XT boasts the best measurement technology available today, meaning it delivers highly precise measurement results.

It is MID certified and compliant with ISO 17089 and AGA9 and compatible with its predecessor FLOWSIC600. It can be integrated successfully into any system. Plus, the new FLOWSIC600-XT Forte meets the requirements of compact installations and is certified to OIML R 137 class 0.5.

Quick and easy device commissioning and checking

i-diagnostics™ helps make device commissioning and checking quick and easy. Furthermore i-diagnostics™ provides extended flowmeter and application diagnostics during operation. Should maintenance ever be required, the intelligent solution wizard provides support.

The built-in infrared interface means measured value and diagnostics data can be accessed in no time, making servicing quick and efficient.

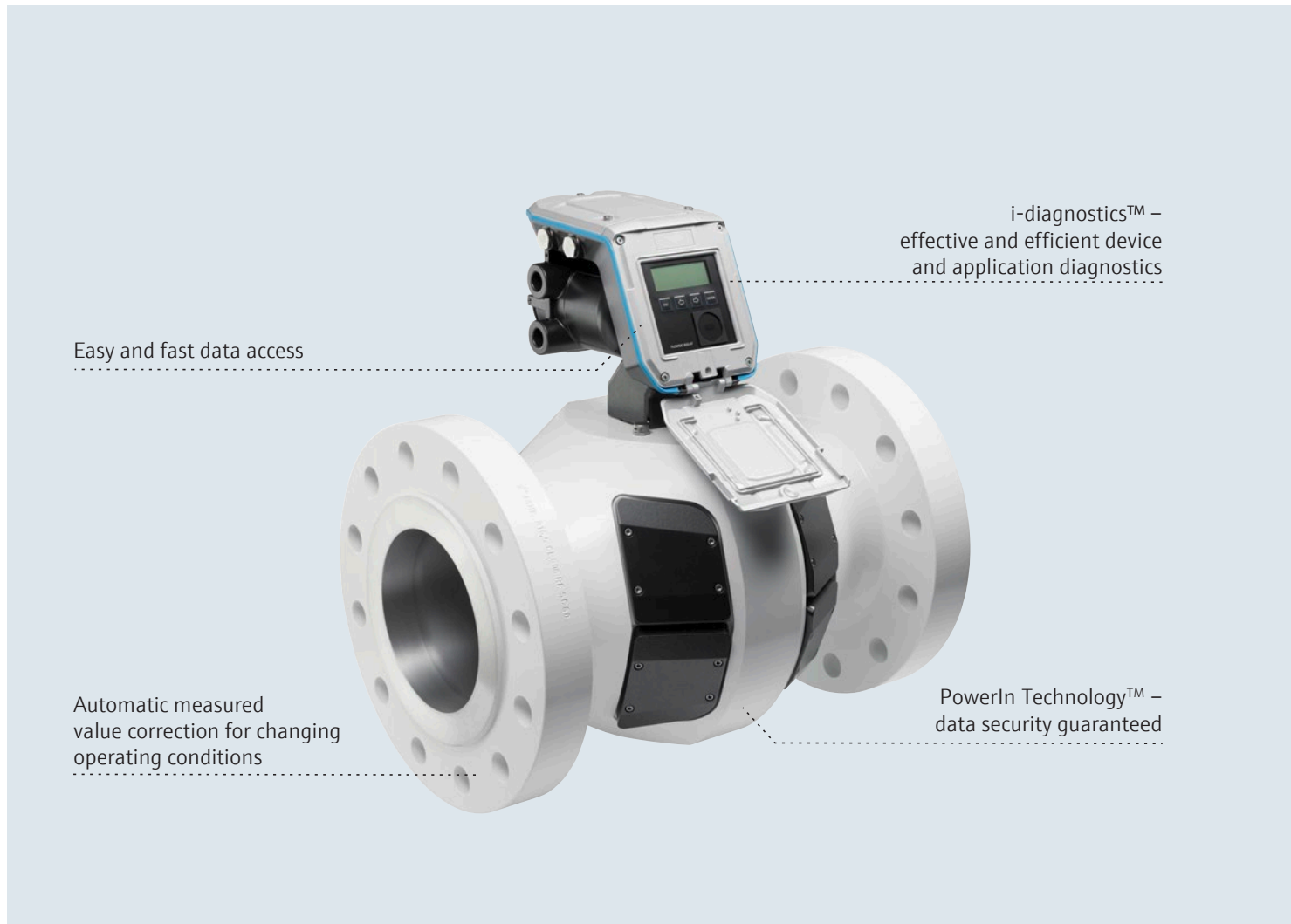

FLWSIC600-XT – Always the right gas flowmeter for your application

Every ultrasonic gas flowmeter of the FLOWVIC600-XT product family is designed for custody transfer gas flow measurement and satisfy the requirements of all current national and international standards. Four device variants are available, whereby every gas flowmeter satisfies very special performance requirements. The selection requirements on a gas flowmeter are not always the same. This performance-oriented classification of FLOWVIC600-XT,

-XT Forte, -XT 2plex and -XT Quatro is therefore helpful as the first step in focusing and solving tasks and meeting customer requirements in a unique manner. No matter which type you chose, every FLOWVIC600-XT can be easily installed into all custody transfer applications with a nominal width between 3 and 48 inches. Connection to all conventional flow computers on the market is also easy.

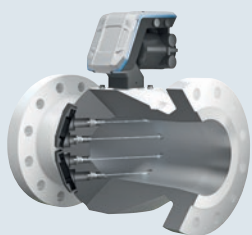

FLWSIC600-XT

FLWSIC600-XT is the proven all-rounder for all natural gas custody transfer applications. 15 years of field experience with FLOWVIC600 flowed into this 4-path technology.

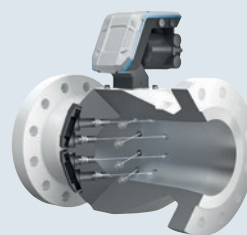

FLWSIC600-XT Forte

A lot of meter for so little space. FLOWVIC600-XT Forte offers 8 paths on two different path levels thereby delivering the highest measurement accuracy. It is automatically the first choice for installations in plants with short inlet and outlet zones.

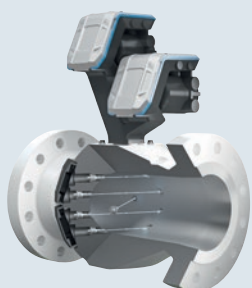

FLWSIC600-XT 2plex

The very compact FLOWVIC600-XT 2plex combines a gas flowmeter for custody transfer with a control measurement device, and features extended diagnostic functionality thanks to its additional independent measurement path.

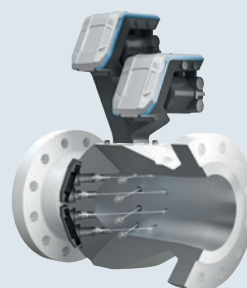

FLWSIC600-XT Quatro

For redundant measurements in custody transfer of natural gas, FLOWVIC600-XT Quatro combines two measurement devices in one – with an installation length equivalent to that of a single device.

Gas Quality Indicator (GQI)*

Today's gas market is served by a large number of different gas suppliers. With FLOWSIC600-XT, plant and network operators are prepared for this challenge. The gas flowmeter is not only officially approved for up to 30% hydrogen content in the natural gas (according to MID), it comes with a Gas Quality Indicator that allows the hydrogen content in the natural gas to be monitored. If the configured limit value is exceeded due to fluctuations in the gas qualities, FLOWSIC600-XT reports this automatically to a control

center. This enables changes in the hydrogen content and also the heating value to be detected in real time and substantial savings in time and costs to be achieved. The Gas Quality Indicator, which is based on the i-diagnostic™ technology, assists in optimizing the network balance. It thereby makes a significant contribution to guaranteeing the contractually agreed gas qualities when measuring the gas quality using a gas chromatograph or measuring the hydrogen content is not possible.



Measuring capability up to 30% hydrogen
in the natural gas

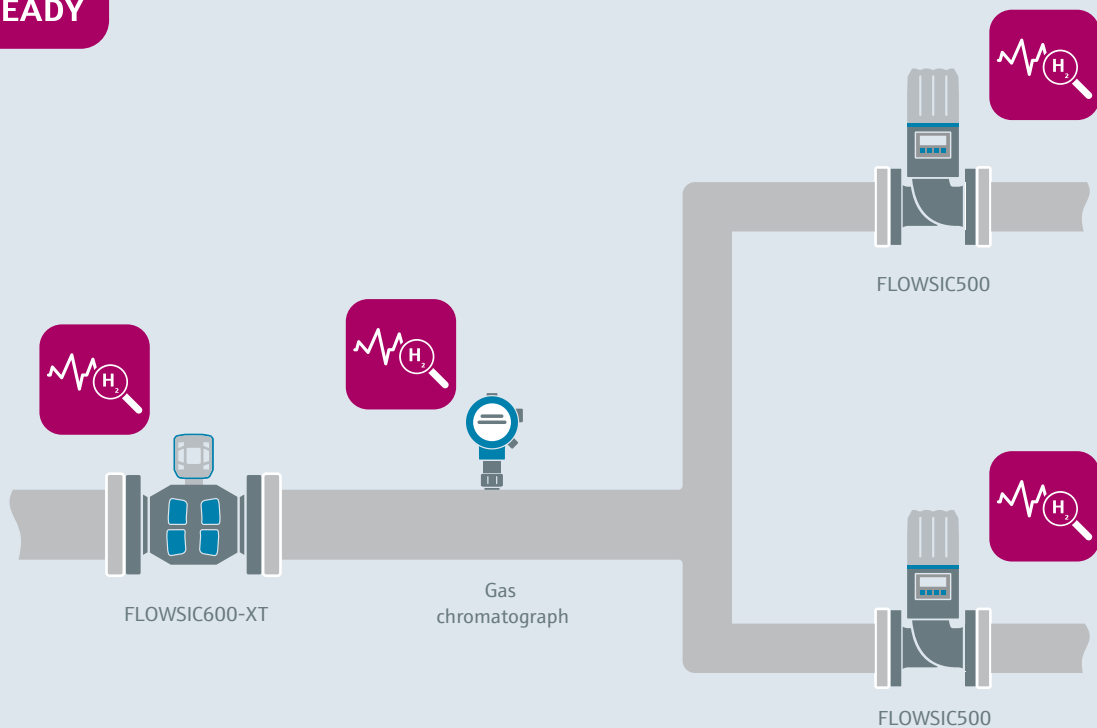

* Not yet available in all sales regions (as at 12/2024)

FLOWgate™ – The intuitively designed operating software

FLOWgate™ intelligently links the diagnostic data and presents them in a processed form. The quick status function provides immediate information about the current status of the application, and if a warning limit is reached, the solution wizard can be used to analyze the problem at the click of a button. In order to get a quick overview or analysis, each user can put together measured values and diagnostics parameters as required in the measure value overview, and then amend or save their overview.

FLOWgate™ provides online or offline access to FLOWSIC600-XT and therefore to all the measured value and diagnostic data at any time via a PC or a tablet. The graphic preparation of trend analyses simplifies evaluation of the measurement sequence and gives information about changes to the process. The report manager can be used to create compact diagnostic, maintenance and calibration reports at any time. Different assistance functions, such as for commissioning, considerably simplify device operation.

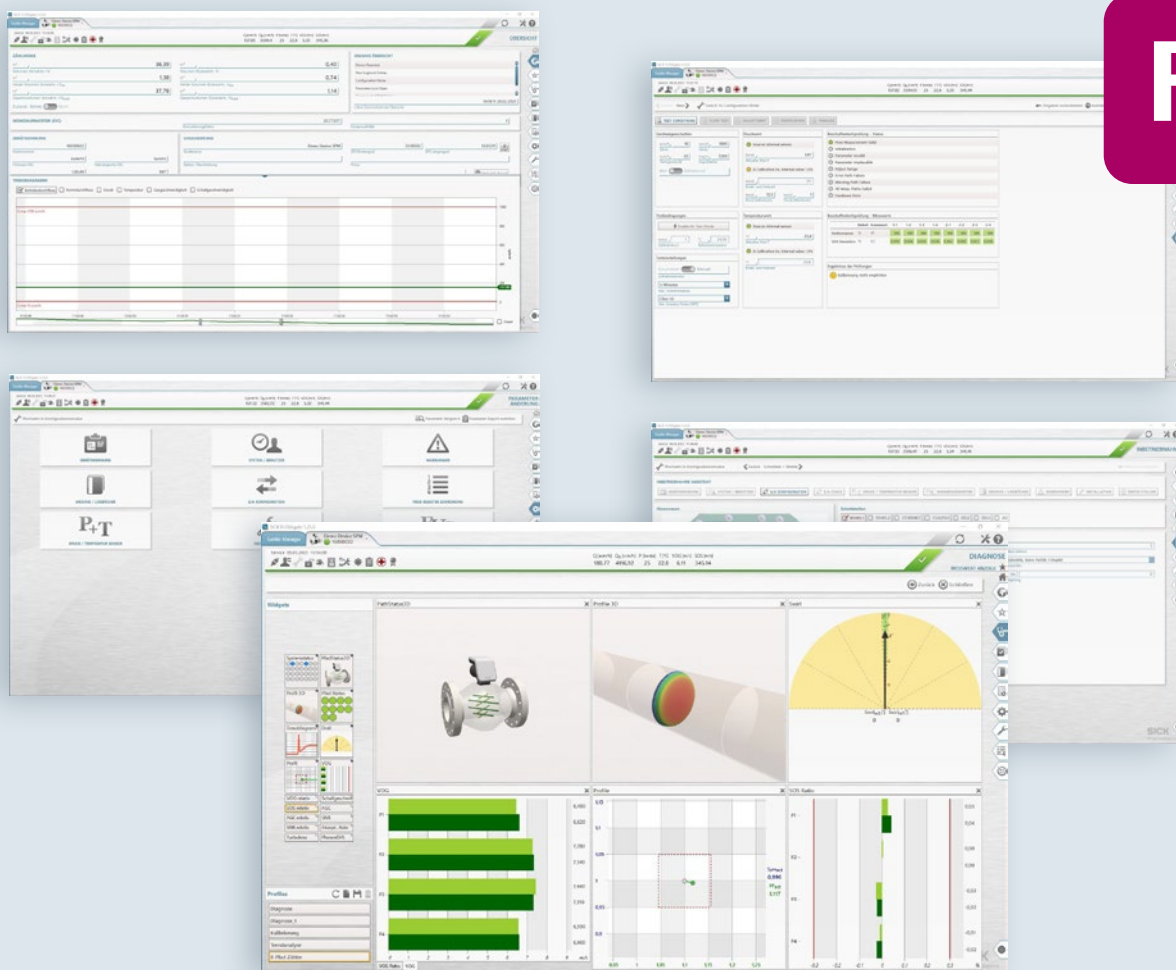

FLAWSIC600-XT: The Perfect Match



Product Description

As the successor to the successful FLOWSIC600, the FLOWSIC600-XT ultrasonic gas flow measuring instrument is setting new standards in its market segment. FLOWSIC600-XT is available in variants with 4, 4+1, 4+4, and 8 measurement paths to meet the requirements of every application, whether it is being used as a stand-alone or system solution. In addition to the OIML R 137 Class 1.0 requirements, FLOWSIC600-XT meets the requirements of Class 0.5 and AGA9 in their entirety.

At a glance

- User-friendly product family
- Automatic correction of pressure and temperature influences
- Available for all operating conditions
- PowerIn Technology™ for reliable backup operation
- Intelligent application diagnostics with i-diagnostics™
- Can be extended to include flow computers using connect-and-go technology
- Measuring capability up to 30% H₂ in the natural gas
- Gas Quality Indicator for quantifying the H₂ content

Your benefits

- Low measurement uncertainty in every application
- High measurement data reliability and availability
- The right ultrasonic gas flowmeter for every application – without compromise
- Simple device integration – even in compact systems
- Quick and easy commissioning and checking
- Cost-effective quantification of the H₂ content in natural gas

Fields of application

- Custody transfer measurement of natural gas with up to 30% H₂
- Transport and storage of gas
- Onshore and offshore applications
- Gas production applications with H₂S and CO₂ content



More Information online

For more information, enter the link or scan the QR code to get direct access to technical data, operating instructions, software, application examples, and much more.

www.endress.com/flowsic600-xt



Technical data

The precise device specifications and product performance data may vary and are dependent on the respective application and customer specifications.

FLAWSIC600-XT					
Measured values	Volumetric flow, a. c., volume a. c., gas velocity, speed of sound, optional volume correction via integrated EVC				
Number of measuring paths	4 4+1 (2plex) 4+4 (Quattro) 8 (Forte) 2				
Measurement principle	Ultrasonic transit time difference measurement				
Measuring medium	Natural gas (with up to 30% hydrogen), air, natural gases containing increased levels of CO ₂ , N ₂ , H ₂ S, O ₂				
Measuring ranges	<table border="0"> <tr> <td style="text-align: right; padding-right: 10px;">Q_{min}</td> <td>5 m³/h ... 1,000 m³/h (180 cf/h ... 35,300 cf/h)</td> </tr> <tr> <td style="text-align: right; padding-right: 10px;">Q_{max}</td> <td>1,000 m³/h ... 120,000 m³/h (35,000 cf/h ... 4,238,000 cf/h)</td> </tr> </table> Measuring ranges depend on nominal pipe size	Q_{min}	5 m ³ /h ... 1,000 m ³ /h (180 cf/h ... 35,300 cf/h)	Q_{max}	1,000 m ³ /h ... 120,000 m ³ /h (35,000 cf/h ... 4,238,000 cf/h)
Q_{min}	5 m ³ /h ... 1,000 m ³ /h (180 cf/h ... 35,300 cf/h)				
Q_{max}	1,000 m ³ /h ... 120,000 m ³ /h (35,000 cf/h ... 4,238,000 cf/h)				
Repeatability	≤ 0.05% of the measured value (typical) ≤ 0.1 % of the measured value for 2-path type				
Accuracy	Typical error limits $Q_t \dots Q_{max} \mid (Q_{min} \dots Q_t)$				
4-path and 8-path type	≤ ± 0.5% (±1.0%) Dry calibrated				
4-path and 8-path type	≤ ± 0.2% (± 0.5%) After flow calibration and adjustment with constant factor. Without uncertainty of the calibration test facility.				
4-path and 8-path type	≤ ± 0.1% (±0.2%) After flow calibration and adjustment using polynomial or piecewise correction. Without uncertainty of the calibration test facility.				
2-path type	≤ ±1.5% (± 3.0%) Dry calibrated				
2-path type	≤ ±0.5% (± 1%) After flow calibration and adjustment. Without uncertainty of the calibration test facility.				
Min. pipe requirements					
4-path type	According to OIML Class 1.0: with straight inlet zone of ≥ 10D or ≥ 5D with flow conditioner According to OIML Class 0.5: with straight inlet zone of ≥ 10D and flow conditioner				
8-path type	According to OIML Class 1.0: with straight inlet zone of ≥ 2D According to OIML Class 0.5: with straight inlet zone of ≥ 5D				
2-path type	According to OIML Class 1.5: with straight inlet zone of ≥ 50D or ≥ 20D with flow conditioner				
	For details, see the operating instructions				
Diagnostic functions					
i-diagnostics™	Integrated device diagnostics, and advanced intelligent device and application diagnostics via FLOWgate™ operating software				

Gas temperature		-46 °C ... +180 °C (-51 °F ... +356 °F) -196 °C ... +230 °C (-321 °F ... +446 °F) (with offset SPU)
Operating pressure		0 bar(g) ... 450 bar(g) (0 psi(g) ... 6527 psi(g))
Nominal pipe size		3" ... 56" / DN 80 ... DN 1400 2" ... 56" / DN 50 ... DN 1400 (2-path type)
Ambient temperature		-46 °C ... +70 °C (-51 °F ... +158 °F) -60 °C ... +70 °C (-76 °F ... +158 °F) (with electronics enclosure)
Storage temperature		-40 °C ... +70 °C (-40 °F ... +158 °F) -60 °C ... +70 °C (-76 °F ... +158 °F) (meter body only)
Ambient humidity		≤ 95%; relative humidity; non-condensing
Conformities		OIML R 137-1&2:2012 (class 0.5) OIML D 11:2013 ISO 17089-1 AGA Report No. 9 MID: 2014/32 / EU PED: 2014/68 / EU AMSE B16.5, B16.47A/B ATEX: 2014/34 / EU EMC: 2014/30 / EU GOST 8.611-2013 GOST 8.733-2011 CPA (JJG1030-2007) CPA: JJG1030-2007 PCEC: GB 3836.1-2010, GB 3836.2-2010, GB 3836.4-2010, GB/T 3836.22-2017
Ex approvals		
	IECEX	Ex db ia op is [ia Ga] IIA/IIC T4 Gb Ex db eb ia op is [ia Ga] IIA/IIC T4 Gb Ex ia op is IIA/IIC T4 Ga
	ATEX	II 2 (1) G Ex db ia op is [ia Ga] IIA/IIC T4 Gb II 2 (1) G Ex db eb ia op is [ia Ga] IIA/IIC T4 Gb II 1G Ex ia op is IIA/IIC T4 Ga
	NEC/CEC (US/CA)	Explosion-proof/non-explosive: Cl I, Div. 1 Group D, T4 Ex db ia [ia Ga] IIA T4 Gb / Cl I, Zone 1 AEx db ia op is [ia Ga] IIA T4 Gb Cl I, Div. 1 Groups B, C, D, T4 Ex db ia [iaGa] IIC T4 Gb / Cl I, Zone 1 AEx db ia op is [ia Ga] IIC T4 Gb Intrinsic safety: Cl I, Div. 1 Group D T4 Ex ia IIA T4 Ga / Cl I, Zone 0, AEx ia op is IIA T4 Ga Cl I, Div. 1 Groups A, B, C, D, T4 Ex ia IIC T4 Ga / Cl I, Zone 0, AEx ia op is IIC T4 Ga
Enclosure rating		IP66 / IP67
Analog outputs		1 output: 4 mA ... 20 mA, ≤ 250 Ω; active/passive, galvanically isolated
Digital outputs		4 outputs: 2 x status, 2 x pulse; ≤ 30 V, 50 mA; passive, galvanically isolated, open collector or conforming to NAMUR (DIN EN 60947-5-6), $f_{max} = 10$ kHz
Modbus		✓
Type of fieldbus integration		TCP RTU RS-485 (3x) ASCII RS-485 (3x)
Ethernet	Note	✓ Option
HART	Note	✓ HART master for connecting external pressure and temperature transmitter

Optical interface	Note	✓ Service interface (IR, according to IEC 62056-21)
Serial	Note	✓ Encoder
Operation		Via display and FLOWgate™ software
Dimensions (W x H x D)		See dimensional drawings and tables
Weight		See "Dimensions" table
Material in contact with media		Low temperature carbon steel, stainless steel, duplex steel
Electrical connection		
	Voltage	Galvanically isolated: 12 V DC ... 24 V DC Intrinsic safety: 6 V DC ... 16 V DC
		PowerIn Technology™ with backup battery (2,400 mAh, 10.8 V), optional
	Power consumption	0.45 W ... 2.45 W Depending on the selected electronics configuration
Integrated components		Integrated pressure sensor and temperature sensor for correcting pressure and temperature influences (option)

Volume correction

Correction method	PTZ (optionally integrated)
Compressibility	SGERG88 AGA 8 Gross method 1 AGA 8 Gross method 2 AGA NX-19 AGA NX-19 mod. NX-19 mod. (GOST) GOST 30319.2-2015 Fixed value
Data archives	1 diagnostic archive (6,000 entries) 2 configurable measuring period archives (6,000 entries each)
Log books	Event log book (1,000 entries) Parameter log book (200 entries) Metrology log book (50 entries)

Measuring ranges [metric]

Nominal size	Extended flow range according to MID and OIML Class 0.5 ¹				
	Extended MID minimum flow rate	Standard flow range according to MID			Non-MID maximum flow rate
		Standard MID minimum flow rate	MID transition flow rate	MID maximum flow rate	
		m ³ /h	m ³ /h	m ³ /h	
Extended Q _{min}	Standard Q _{min}	Q _t	Standard Q _{max}	Extended Q _{max}	
DN 80 (3")	5	8	40	650	1,000
DN 100 (4")	8	13	65	1,000	1,600
DN 150 (6")	16	20	100	2,500	3,000
DN 200 (8")	20	32	160	4,000	4,500
DN 250 (10")	25	50	240	6,500	7,000
DN 300 (12")	35	65	310	7,800	8,000
DN 350 (14")	45	80	420	10,000	10,000
DN 400 (16")	60	120	550	13,000	14,000
DN 450 (18")	100	130	700	16,000	17,000
DN 500 (20")	130	200	850	20,000	20,000
DN 550 (22")	150	260	1,000	24,000	24,000
DN 600 (24")	180	320	1,200	28,000	32,000
DN 650 (26")	240	450	1,400	32,000	35,000
DN 700 (28")	280	650	1,700	36,000	40,000
DN750 (30")	320	650	1,900	40,000	45,000
DN 800 (32")	360	800	2,200	43,000	50,000
DN 850 (34")	400	900	2,500	47,000	55,000
DN 900 (36")	450	1,000	2,800	51,000	66,000
DN 950 (38")	500	1,100	3,100	56,000	70,000
DN 1000 (40")	550	1,200	3,400	60,000	80,000
DN 1050 (42")	600	1,300	3,800	65,000	85,000
DN 1100 (44")	650	1,400	4,100	70,000	90,000
DN 1150 (46")	700	1,500	4,500	72,000	95,000
DN 1200 (48")	750	1,600	4,800	80,000	100,000
DN 1300 (52")	900	1,700	5,600	90,000	110,000
DN 1400 (56")	1,000	1,800	6,500	100,000	120,000

For an installation configuration with flow conditioner, the maximum allowed gas velocity in the pipe is limited to 40 m/s.

¹ Q_{min} values may vary (see OIML R137 certificate)

Measuring ranges [imperial²]

Nominal size	Extended flow range according to MID and OIML Class 0.5 ¹				
	Extended MID minimum flow rate	Standard flow range according to MID			
		Standard MID minimum flow rate	MID transition flow rate	MID maximum flow rate	Non-MID maximum flow rate
		cf/h	cf/h	cf/h	cf/h
Extended Q _{min}	Standard Q _{min}	Q _t	Standard Q _{max}	Extended Q _{max}	
3" (DN 80)	180	280	1,400	23,000	35,000
4" (DN 100)	290	460	2,300	35,300	56,000
6" (DN 150)	570	710	3,500	88,000	106,000
8" (DN 200)	710	1,130	5,700	141,300	159,000
10" (DN 250)	880	1,800	8,500	230,000	247,000
12" (DN 300)	1,200	2,300	10,900	276,000	283,000
14" (DN 350)	1,600	2,800	14,800	353,000	354,000
16" (DN 400)	2,100	4,200	19,400	459,000	495,000
18" (DN 450)	3,500	4,600	24,700	565,000	602,000
20" (DN 500)	4,600	7,100	30,000	706,000	708,000
22" (DN 550)	5,300	9,200	35,000	848,000	850,000
24" (DN 600)	6,400	11,300	42,000	989,000	1,133,000
26" (DN 650)	8,500	15,900	49,000	1,130,000	1,240,000
28" (DN 700)	9,900	23,000	60,000	1,271,000	1,420,000
30" (DN 750)	11,300	23,000	67,000	1,413,000	1,590,000
32" (DN 800)	12,700	28,300	78,000	1,519,000	1,770,000
34" (DN 850)	14,200	31,800	88,000	1,660,000	1,950,000
36" (DN 900)	15,900	35,300	99,000	1,801,000	2,337,000
38" (DN 950)	17,700	38,800	109,000	1,978,000	2,479,000
40" (DN 1000)	19,500	42,400	120,000	2,119,000	2,833,000
42" (DN 1050)	21,200	45,900	134,000	2,296,000	3,010,000
44" (DN 1100)	23,000	49,400	145,000	2,472,000	3,187,000
46" (DN 1150)	24,800	53,000	159,000	2,543,000	3,364,000
48" (DN 1200)	26,600	56,500	170,000	2,825,000	3,541,000
52" (DN 1300)	31,800	60,000	198,000	3,178,000	3,885,000
56" (DN 1400)	35,300	63,600	230,000	3,532,000	4,238,000

For an installation configuration with flow conditioner, the maximum allowed gas velocity in the pipe is limited to 131 ft/s

¹ Qmin values may vary (see OIML R137 certificate)

² Conversion of MID-approved values into imperial units (rounded)

Order information

Our regional sales organization will be glad to advise you on which device configuration is best for you.

Dimensional drawings

FLAWSIC600-XT and FLOWSIC600-XT Forte (dimensions in mm)

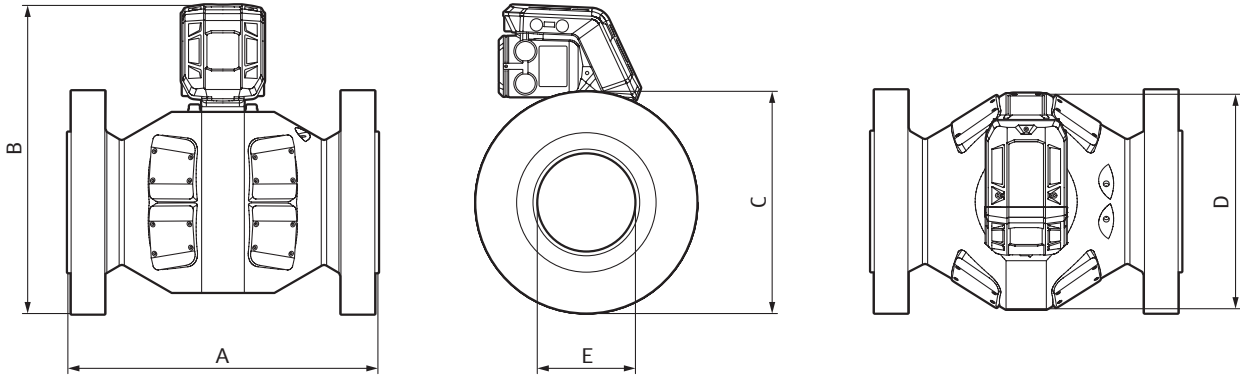

FLAWSIC600-XT 2plex and FLOWSIC600-XT Quatro

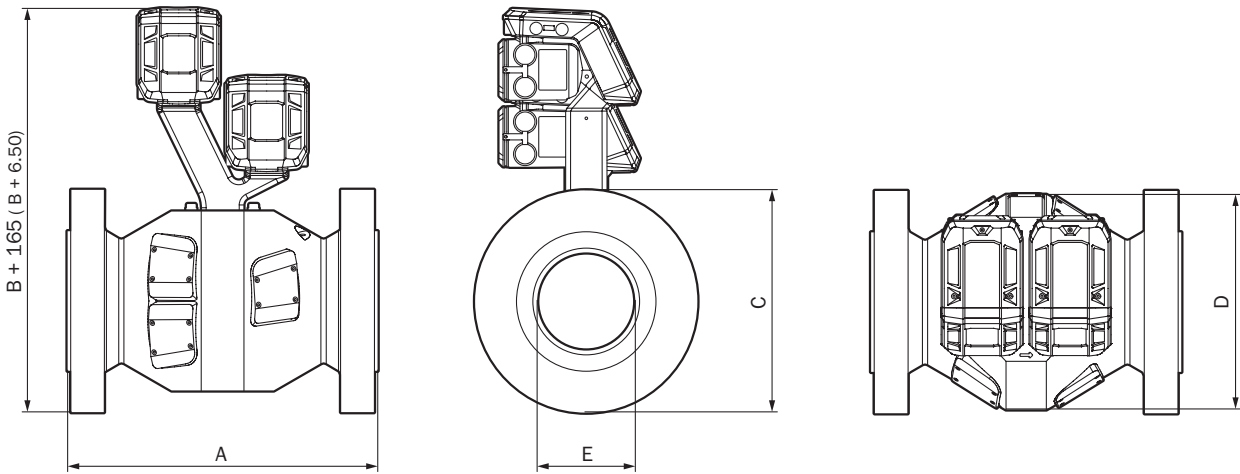

FLAWSIC600-XT: 3" type for up to Class 600 / PN100 pressure levels

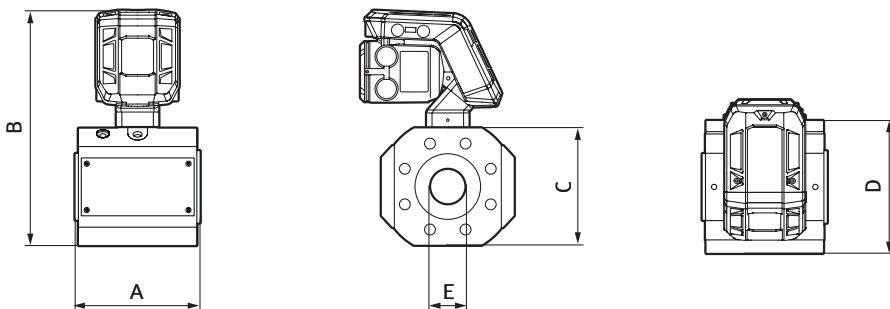

Dimensions [metric]

Nominal pipe size	Con- nection flange	Standard	Weight ¹⁾	Length (A)	Height ²⁾ (B)	Flange diameter (C)	Measur- ing range width (D)	Interior diameter (E)	
			kg	mm	mm	mm	mm	mm	
3"	Cl. 150	ANSI B16.5	75	240	454	190	205	73	
	Cl. 300		75		454				210
	Cl. 600		75		454				210
	Cl. 900		120		400				461
DN 80	PN 16	DIN 2633	75	240	454	200			
	PN 63	DIN 2636	75		454				215
	PN 100	DIN 2637	75		454				230
4"	Cl. 150	ANSI B16.5	100	300	490	230	248	95	
	Cl. 300		110		490				255
	Cl. 600		120		490				275
	Cl. 900		130		500				490
DN 100	PN 16	DIN 2633	110	300	490	220			
	PN 63	DIN 2636	120		490				250
	PN 100	DIN 2637	126		490				265
6"	Cl. 150	ANSI B16.5	128	450	510	280	330	142	
	Cl. 300		145		525				320
	Cl. 600		170		545				355
	Cl. 900		238		750				570
DN 150	PN 16	DIN 2633	140	450	510	285			
	PN 63	DIN 2636	162		525				345
	PN 100	DIN 2637	176		545				355
8"	Cl. 150	ANSI B16.5	255	600	617	345	415	190	
	Cl. 300		276		617				380
	Cl. 600		316		617				420
	Cl. 900		360		617				470
DN 200	PN 16	DIN 2633	260		617	340			
	PN 63	DIN 2636	298		617				415
	PN 100	DIN 2637	360		617				430
10"	Cl. 150	ANSI B16.5	377	750	691	405	420	235	
	Cl. 300		411		691				445
	Cl. 600		485		691				510
	Cl. 900		528		691				545
DN 250	PN 16	DIN 2633	383		691	405			
	PN 63	DIN 2636	434		691				470
	PN 100	DIN 2637	486		691				505

Nominal pipe size	Con- nection flange	Standard	Weight ¹⁾	Length (A)	Height ²⁾ (B)	Flange diameter (C)	Measur- ing range width (D)	Interior diameter (E)	
			kg	mm	mm	mm	mm	mm	
12"	Cl. 150	ANSI B16.5	445	900	728	485	500	270	
	Cl. 300		494		728				520
	Cl. 600		560		728				560
	Cl. 900		645		685				610
DN 300	PN 16	DIN 2633	441		728	460			
	PN 63	DIN 2636	509		728	530			
	PN 100	DIN 2637	585		638	585			
14"	Cl. 150	ANSI B16.5	475	1,050	642	535	540	315	
	Cl. 300		600		667				585
	Cl. 600		675		677				605
	Cl. 900		850		700				640
DN 350	PN 16	DIN 2633	475		635	520			
	PN 63	DIN 2636	625		675	600			
	PN 100	DIN 2637	750		705	655			
For all meters ≥ 16", an installation length of 3D is optionally available									
16"	Cl. 150	ANSI B16.5	672	762	844	595	610	360	
	Cl. 300		760		844				650
	Cl. 600		857		844				685
	Cl. 900		926		800				755
DN 400	PN 16	DIN 2633	658	762	844	580			
	PN 63	DIN 2636	794		844	670			
18"	Cl. 150	ANSI B16.5	660	820	754	635	620	405	
	Cl. 300		760		792				710
	Cl. 600		960		820				745
	Cl. 900		1,300		900				830
DN 450	Data on request								
20"	Cl. 150	ANSI B16.5	750	902	815	700	670	450	
	Cl. 300		930		853				775
	Cl. 600		1,080		872				815
	Cl. 900		1,500		1,000				892
DN 500	PN 16	DIN 2633	700	902	823	715			
22"	Data on request								
DN 550	Data on request								
24"	Cl. 150	ANSI B16.5	1,090	991	927	815	760	540	
	Cl. 300		1,390		978				915
	Cl. 600		1,615		990				940
	Cl. 900		2,100		1,200				1,040
DN 600	PN 16	DIN 2633	1,015	991	940	840			
26"	Cl. 150	ASME B16.47	1,475	1,050	965	870	828	585	
	Cl. 300		1,825		1,016				972
	Cl. 600		2,100		1,038				1,016
	Cl. 900		2,500		1,250				1,073

Nominal pipe size	Con- nection flange	Standard	Weight ¹⁾	Length (A)	Height ²⁾ (B)	Flange diameter (C)	Measur- ing range width (D)	Interior diameter (E)	
			kg	mm	mm	mm	mm	mm	
DN 650	Data on request								
28"	Cl. 150	ASME B16.47	1,950	1,100	1,027	927	862	630	
	Cl. 300		2,225		1,080				1,035
	Cl. 600		2,450		1,100				1,073
	Cl. 900		3,000		1,300				1,150
DN 700	Data on request								
30"	Cl. 150	ASME B16.47	2,195	1,150	1,080	985	902	675	
	Cl. 300		2,545		1,135				1,092
	Cl. 600		2,820		1,154				1,130
	Cl. 900		3,350		1,350				1,205
DN 750	Data on request								
32"	Cl. 150	ASME B16.47	2,485	1,200	1,145	1,061	979	720	
	Cl. 300		2,835		1,190				1,150
	Cl. 600		3,110		1,212				1,194
	Cl. 900		3,800		1,400				1,272
DN 800	Data on request								
34"	Data on request								
DN 850	Data on request								
36"	Cl. 150	ASME B16.47	3,125	1,250	1,250	1,169	1,082	810	
	Cl. 300		3,525		1,300				1,270
	Cl. 600		3,850		1,323				1,315
	Cl. 900		5,225		1,450				1,396
DN 900	Data on request								
38"	Cl. 150	ASME B16.47	3,800	1,300	1,310	1,238	1,160	855	
	Cl. 300		3,725		1,275				1,169
	Cl. 600		4,300		1,325				1,270
	Cl. 900		Data on request		1,421				1,461
DN 950	Data on request								
40"	Cl. 150	ASME B16.47	3,825	1,350	1,359	1,289	1,213	900	
	Cl. 300		4,125		1,334				1,239
	Cl. 600		4,675		1,375				1,321
	Cl. 900		Data on request		1,470				1,512
DN 1000	Data on request								
42"	Cl. 150	ASME B16.47	4,675	1,450	1,415	1,346	1,261	945	
	Cl. 300		4,650		1,386				1,289
	Cl. 600		5,450		1,444				1,404
	Cl. 900		Data on request		1,523				1,562
DN 1050	Data on request								
44"	Data on request								
DN 1100	Data on request								
46"	Data on request								
DN 1150	Data on request								

Nominal pipe size	Con- nection flange	Standard	Weight ¹⁾	Length (A)	Height ²⁾ (B)	Flange diameter (C)	Measur- ing range width (D)	Interior diameter (E)
			kg	mm	mm	mm	mm	mm
48"	Cl. 150	ASME B16.47	6,400	1,600	1,574	1,511	1,416	1,080
	Cl. 300		6,475		1,552	1,467		
	Cl. 600		7,850		1,615	1,594		
	Cl. 900		12,100		1,900	1,711		
DN 1200	Data on request							

¹ Devices with one measuring transducer, devices with two measuring transducers: weight + 7 kg

² Optional neck extension: B + 200 mm

Dimensions [imperial]

Nominal pipe size	Con- nection flange	Standard	Weight ¹⁾	Length (A)	Hight ²⁾ (B)	Flange diameter (C)	Width of measur- ing section (D)	Internal diameter (E)
			[lbs]	[inch]	[inch]	[inch]	[inch]	[inch]
3"	Cl. 150	ANSI B16.5	275.58	15.75	17.87	7.48	8.07	2.87
	Cl. 300		286.60		17.87	8.27		
	Cl. 600		286.60		17.87	8.27		
	Cl. 900		286.60		18.15	9.45		
DN 80	PN 16	DIN 2633	233.69		17.87	7.87		
	PN 63	DIN 2636	233.69		17.87	8.46		
	PN 100	DIN 2637	233.69		17.87	9.06		
4"	Cl. 150	ANSI B16.5	401.24	19.69	19.29	9.06	9.76	3.74
	Cl. 300		418.88		19.29	10.04		
	Cl. 600		440.93		19.29	10.83		
	Cl. 900		242.51		19.29	11.42		
DN 100	PN 16	DIN 2633	392.42		19.29	8.66		
	PN 63	DIN 2636	414.47		19.29	9.84		
	PN 100	DIN 2637	414.47		19.29	10.43		
6"	Cl. 150	ANSI B16.5	282.19	17.72	21.26	11.02	12.99	5.59
	Cl. 300		319.67		21.26	12.60		
	Cl. 600		374.79		21.26	13.98		
	Cl. 900		524.70		29.53	21.26		
DN 150	PN 16	DIN 2633	308.65	17.72	21.26	11.22		
	PN 63	DIN 2636	357.15		21.26	13.58		
	PN 100	DIN 2637	388.01		21.26	13.98		

Nominal pipe size	Con- nection flange	Standard	Weight ¹⁾	Length (A)	Hight ²⁾ (B)	Flange diameter (C)	Width of measur- ing sec- tion (D)	Internal diameter (E)
			[lbs]	[inch]	[inch]	[inch]	[inch]	[inch]
8"	Cl. 150	ANSI B16.5	562.18	23.62	24.29	13.58	16.34	7.48
	Cl. 300		608.48		24.29	14.96		
	Cl. 600		696.66		24.29	16.54		
	Cl. 900		793.66		24.29	18.50		
DN 200	PN 16	DIN 2633	573.20		24.29	13.39		
	PN 63	DIN 2636	656.98		24.29	16.34		
	PN 100	DIN 2637	793.66		24.29	16.93		
10"	Cl. 150	ANSI B16.5	831.14	29.53	27.20	15.94	16.54	9.25
	Cl. 300		906.10		27.20	17.52		
	Cl. 600		1069.24		27.20	20.08		
	Cl. 900		1164.04		27.20	21.46		
DN 250	PN 16	DIN 2633	844.37		27.20	15.94		
	PN 63	DIN 2636	956.81		27.20	18.50		
	PN 100	DIN 2637	1071.45		27.20	19.88		
12"	Cl. 150	ANSI B16.5	981.06	35.43	28.66	19.09	19.69	10.63
	Cl. 300		1089.08		28.66	20.47		
	Cl. 600		1234.59		28.66	22.05		
	Cl. 900		1424.98		26.97	24.02		
DN 300	PN 16	DIN 2633	972.24		28.66	18.11		
	PN 63	DIN 2636	1122.15		28.66	20.87		
	PN 100	DIN 2637	1289.70		25.12	23.03		
14"	Cl. 150	ANSI B16.5	1047.19	41.34	25.28	21.06	21.26	12.40
	Cl. 300		1322.77		26.26	23.03		
	Cl. 600		1488.12		26.65	23.82		
	Cl. 900		1873.93		27.56	25.20		
DN 350	PN 16	DIN 2633	1047.19		25.00	20.47		
	PN 63	DIN 2636	1377.89		26.57	23.62		
	PN 100	DIN 2637	1653.47		27.76	25.79		
Fore al meters ≥ 16" an installation length of 3D is optionally available								
16"	Cl. 150	ANSI B16.5	1418.50	30.00	33.23	23.43	24.02	14.17
	Cl. 300		1675.51		33.23	25.59		
	Cl. 600		1889.36		33.23	26.97		
	Cl. 900		2041.48		31.50	29.72		
DN 400	PN 16	DIN 2633	1450.64	30.00	33.23	22.83		
	PN 63	DIN 2636	1750.47		33.23	26.38		
18"	Cl. 150	ANSI B16.5	1455.05	32.28	29.69	25.00	24.41	16.34
	Cl. 300		1675.51		31.18	27.95		
	Cl. 600		2116.44		32.28	29.33		
	Cl. 900		2866.01		35.43	32.68		
DN 450	Data on request							

Nominal pipe size	Con- nection flange	Standard	Weight ¹⁾	Length (A)	Hight ²⁾ (B)	Flange diameter (C)	Width of measur- ing sec- tion (D)	Internal diameter (E)
			[lbs]	[inch]	[inch]	[inch]	[inch]	[inch]
20"	Cl. 150	ANSI B16.5	1653.47	35.51	32.09	27.56	26.38	17.72
	Cl. 300		2050.30		33.58	30.51		
	Cl. 600		2380.99		34.33	32.09		
	Cl. 900		3306.93		39.37	35.12		
DN 500	PN 16	DIN 2633	1543.23	35.51	32.40	28.15		
22"	Data on request							
DN 550	Data on request							
24"	Cl. 150	ANSI B16.5	2403.04	39.02	36.50	32.09	29.92	21.26
	Cl. 300		3064.42		38.50	36.02		
	Cl. 600		3560.46		38.98	37.01		
	Cl. 900		4629.70		47.24	40.94		
DN 600	PN 16	DIN 2633	2237.69	39.02	37.01	33.07		
26"	Cl. 150	ASME B16.47	3251.81	41.34	37.99	34.25	32.60	23.03
	Cl. 300		4023.43		40.00	38.27		
	Cl. 600		4629.70		40.87	40.00		
	Cl. 900		5511.55		49.21	42.24		
DN 650	Data on request							
28"	Cl. 150	ASME B16.47	4299.01	43.31	40.43	36.50	33.94	24.80
	Cl. 300		4905.28		42.52	40.75		
	Cl. 600		5401.32		43.31	42.24		
	Cl. 900		6613.86		51.18	45.28		
DN 700	Data on request							
30"	Cl. 150	ASME B16.47	4839.14	45.28	42.52	38.78	35.51	26.57
	Cl. 300		5610.76		44.69	42.99		
	Cl. 600		6217.03		45.43	44.49		
	Cl. 900		7385.48		53.15	47.44		
DN 750	Data on request							
32"	Cl. 150	ASME B16.47	5478.48	47.24	45.08	41.77	38.54	28.35
	Cl. 300		6250.10		46.85	45.28		
	Cl. 600		6856.37		47.72	47.01		
	Cl. 900		8377.56		55.15	50.08		
DN 800	Data on request							
34"	Data on request							
DN 850	Data on request							
36"	Cl. 150	ASME B16.47	6889.44	49.21	49.21	46.02	42.60	31.889
	Cl. 300		7771.29		51.18	50.00		
	Cl. 600		8487.79		52.09	51.77		
	Cl. 900		11519.14		57.09	54.96		
DN 900	Data on request							

Nominal pipe size	Con- nection flange	Standard	Weight ¹⁾	Length (A)	Hight ²⁾ (B)	Flange diameter (C)	Width of measur- ing sec- tion (D)	Internal diameter (E)
			[lbs]	[inch]	[inch]	[inch]	[inch]	[inch]
38"	Cl. 150	ASME B16.47	8377.56	51.10	51.57	48.74	45.67	33.66
	Cl. 300		8212.21		50.20	46.02		
	Cl. 600		9479.87		52.17	50.00		
	Cl. 900		Data on request		55.94	57.52		
DN 950	Data on request							
40"	Cl. 150	ASME B16.47	8432.67	53.15	53.50	50.75	47.76	35.43
	Cl. 300		9094.06		52.52	48.78		
	Cl. 600		10306.60		54.13	52.01		
	Cl. 900		Data on request		57.87	59.53		
DN 1000	Data on request							
42"	Cl. 150	ASME B16.47	10306.60	57.09	55.71	52.99	49.65	37.20
	Cl. 300		10251.48		54.57	50.75		
	Cl. 600		12015.18		56.85	55.28		
	Cl. 900		Data on request		59.96	61.50		
DN 1050	Data on request							
44"	Data on request							
DN 1100	Data on request							
46"	Data on request							
DN 1150	Data on request							
48"	Cl. 150	ASME B16.47	14109.57	62.99	61.97	59.49	55.75	42.52
	Cl. 300		14274.19		61.10	57.76		
	Cl. 600		17306.27		63.85	62.76		
	Cl. 900		26675.90		74.80	70.28		
DN 1200	Data on request							

¹ Devices with single SPU; devices with double SPU: weight + 7 kg (15.4 lbs)

² Optional neck extension: B + 200 mm (7.9 in)

Mounting instructions

Installation in the pipeline for unidirectional use (minimum requirements)

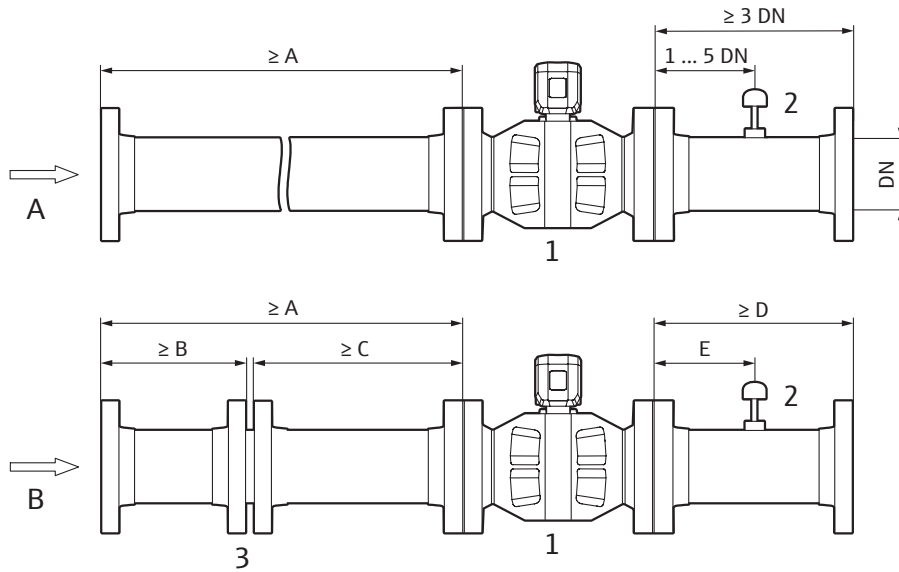

- 1 FLOWSIC600-XT
 2 Temperature measuring point
 3 Flow conditioner

Configuration A			Configuration B						
Number of measuring paths	OIML R 137	A	Number of measuring paths	OIML R 137 A ¹	A	B	C	D	E
4	Class 1.0	10 DN	4	Class 1.0	5 DN	2 DN	3 DN	3 DN	1 ... 5 DN
8	Class 1.0	2 DN	4	Class 0.5	10 DN	2 DN	8 DN	3 DN	1 ... 5 DN
8	Class 0.5	5 DN	8	Class 1.0	5 DN	2 DN	3 DN	3 DN	1 ... 5 DN
2	Class 1.5	50 DN	2	Class 1.5	20 DN	10 DN	10 DN	3 DN	1 ... 5 DN
Number of measuring paths	AGA Report 9, 4th Edition, 2022	A	Number of measuring paths	AGA Report 9 ²	A	B	C	D	E
4	"Metering package performance" according to § 6.3	10 DN	4	"Metering package performance" according to § 6.3	10 DN	5 DN	5 DN	3 DN	2 ... 5 DN
8	"Metering package performance" according to § 6.3	5 DN	8	"Metering package performance" according to § 6.3	5 DN	2 DN	3 DN	3 DN	2 ... 5 DN

¹ Minimum requirements with our flow conditioner (PTB type); Installation recommendations for other flow conditioners on request

² Minimum requirements with CPA50E, CPA55E or our flow conditioner (PTB type); installation recommendations for other flow conditioners on request

Installation in the pipeline for bidirectional use (minimum requirements)

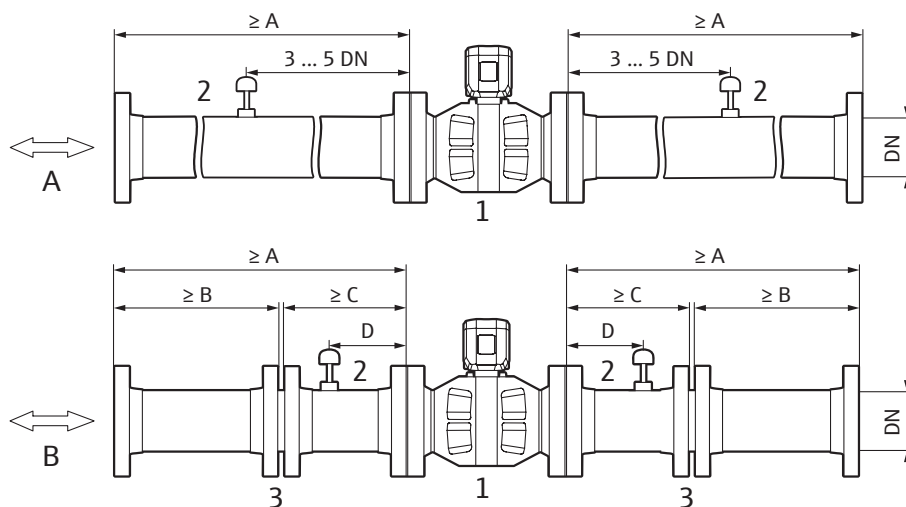

- 1 FLOWSIC600-XT
- 2 Alternative temperature measuring points
- 3 Flow conditioner

Configuration A			Configuration B					
Number of measuring paths	OIML R 137	A	Number of measuring paths	OIML R 137 A ¹	A	B	C ³	D
4	Class 1.0	10 DN	4	Class 1.0	5 DN	2 DN	3 DN	3 ... 5 DN
8	Class 1.0	5 DN	4	Class 0.5	10 DN	2 DN	8 DN	3 ... 5 DN
8	Class 0.5	5 DN	8	Class 1.0	5 DN	2 DN	3 DN	3 ... 5 DN
2	Class 1.5	50 DN	2	Class 1.5	20 DN	10 DN	10 DN	3 ... 5 DN
Number of measuring paths	AGA report 9, A 4th Edition, 2022	A	Number of measuring paths	AGA report 9, 4th Edition, 2022 ²	A	B	C ³	D ⁴
4	"Metering package performance" according to § 6.3	10 DN	4	"Metering package performance" according to § 6.3	10 DN	5 DN	5 DN	2 ... 5 DN
8	"Metering package performance" according to § 6.3	5 DN	8	"Metering package performance" according to § 6.3	6 DN	3 DN	3 DN	2 ... 5 DN

¹ Minimum requirements with our flow conditioner (PTB type); installation recommendations for other flow conditioners on request

² Minimum requirements with CPA50E, CPA55E or our flow conditioner (PTB type); installation recommendations for other flow conditioners on request

³ If C ≥ 5 DN, the temperature measuring point must be located in the pipe section C at a distance of 3 ... 5 DN

⁴ Measuring distances must be calibrated for the temperature measuring point with a thermowell installed

www.addresses.endress.com

Eco-friendly produced and printed on paper
from sustainable forestry.

IN 8029732 / EHS / EN / 04.00