

Safety Instructions

J22 TDLAS gas analyzer

ATEX/IECEX/UKEX Zone 1, cCSAus Class I, Division 1/Zone 1

Safety instructions for the J22 TDLAS gas analyzer in explosion-hazardous areas



Table of Contents

1	Introduction	4
1.1	Intended equipment use.....	4
1.2	Documentation.....	4
1.3	Manufacturer's certificates.....	4
1.4	Manufacturer address	5
2	General safety	6
2.1	Warnings	6
2.2	Symbols.....	6
2.3	U.S. export compliance	6
2.4	Labels	6
2.5	Personnel qualifications.....	8
2.6	Equipment training.....	8
2.7	Potential risks affecting personnel	9
2.8	Analyzer technical specifications	9
3	Installation.....	12
3.1	Lifting and moving the analyzer	12
3.2	Mounting the analyzer	12
3.3	Opening and closing the analyzer enclosure.....	14
3.4	Protective chassis and ground connections.....	14
3.5	Electrical wiring requirements	16
3.6	IS flow switch connection requirements.....	17
3.7	Connection values: signal circuits	18
3.8	Electrical circuit breakers.....	18
3.9	Connecting the gas supply	18
3.10	Sample system heater	18
4	Equipment operation.....	19
4.1	Operating controls	19
4.2	Commissioning.....	19
4.3	Decommissioning.....	19
5	Maintenance and service	20
5.1	Cleaning and decontamination	20
5.2	Troubleshooting and repairs.....	20
5.3	Spare parts.....	23
5.4	Service	23

1 Introduction

Endress+Hauser's J22 TDLAS gas analyzer is a laser-based extractive analyzer for measuring gas concentration. The technology employed is tunable diode laser absorption spectroscopy (TDLAS). Typical measurement ranges vary between 0 to 10 parts-per-million by volume (ppmv) and 0 to 100 % by volume.

1.1 Intended equipment use

The J22 TDLAS gas analyzer is intended for use as instructed in the documentation package provided with the equipment. This information should be read and referenced by anyone installing, operating, or having direct contact with the analyzer. Any use of the equipment in a manner not specified by Endress+Hauser could impair the protection provided by the equipment.

1.2 Documentation

All documentation is available:

- On the Endress+Hauser mobile app: www.endress.com/supporting-tools
- In the Downloads area of the Endress+Hauser website: www.endress.com/downloads

Each analyzer shipped from the factory is packaged with documents specific to the model that was purchased. This document is an integral part of the complete document package, which also includes:

Part Number	Document Type	Description
BA02152C	Operating Instruction	A complete overview of the operations required to install, commission, and maintain the device.
TI01607C	Technical Information	Provides technical data on the device with an overview of associated models available.
GP01198C	Description of device parameters	Reference for parameters, providing a detailed explanation of each individual parameter of the operating menu
SD03286C	Special Documentation	Description, guidelines, and procedure for validation of TDLAS gas analyzers.
EA01501C	Installation Instructions	Instructions for replacing measurement components for the J22 TDLAS gas analyzer.
EA01426C	Installation Instructions	Installation instructions for the J22 and JT33 TDLAS gas analyzer firmware upgrade.
EA01507C	Installation Instructions	Installation instructions for replacing the J22 and JT33 TDLAS gas analyzer electronics and display.

1.3 Manufacturer's certificates

cCSAus Certificate of Conformity

Certificate number: CSA21CA80053040

ATEX/IECEX Certificate of Conformity

Certificate number: CSANe 20ATEX1197X / IECEX SIR 20.0035X

UKEX Certificate of Conformity

Certificate number: CSAE 21UKEX1072X



J22 TDLAS Gas Analyzer, J22 TDLAS Gas Analyzer with SCS on Panel, J22 TDLAS Gas Analyzer with Enclosed SCS, J22 TDLAS Gas Analyzer with Enclosed SCS, with Heater	
ATEX/UKEX	IECEX
EN IEC 60079-0:2018 EN 60079-1:2014 + AC:2018-09 EN 60079-11:2012 EN 60079-28:2015 EN ISO 80079-36:2016+AC:2019 IEC TS 60079-40:2015	IEC 60079-0:2017 Ed. 7.0 IEC 60079-1:2014+COR1:2018 Ed. 7 IEC 60079-11:2011 Ed. 6.0 IEC 60079-28:2015 Ed. 2.0 ISO 80079-36:2016+COR1:2019 Ed. 1 IEC TS 60079-40:2015
cCSA	CSAus
CAN/CSA-C22.2 No. 60079-0:19 CSA C22.2 No. 60079-1:16 CAN/CSA-C22.2 No. 60079-11:14 CAN/CSA-C22.2 No. 60079-28:16 CSA C22.2 No. 30-M1986 (R2016) CSA C22.2 No. 60529:16 CSA C22.2 No. 94.2-15 CSA C22.2 No. 0-10 (R2015) CSA C22.2 No. 61010-1-12, UPD1:2015, UPD2:2016, AMD1:2018 CAN / CSA C22.2 No. 60079-40: 2015	ANSI/UL 60079-0-2019 Seventh Edition ANSI/UL 60079-1:2015 Seventh Edition ANSI/UL 60079-11:2013 Seventh Edition UL 60079-28 Second Edition UL 913 Eighth Edition FM 3600:2018 FM 3615:2018 ANSI/UL 50E:2015 UL 61010-1 Ed. 3, AMD1:2018 UL 122701:2017

1.4 Manufacturer address









Endress+Hauser
 11027 Arrow Route
 Rancho Cucamonga, CA 91730
 United States
www.endress.com

2 General safety

2.1 Warnings

Structure of Information	Meaning
 WARNING Causes (/consequences) If necessary, consequences of non-compliance (if applicable) ▶ Corrective action	This symbol alerts you to a dangerous situation. Failure to avoid the dangerous situation can result in a fatal or serious injury.
 CAUTION Causes (/consequences) If necessary, consequences of non-compliance (if applicable) ▶ Corrective action	This symbol alerts you to a dangerous situation. Failure to avoid this situation can result in minor or more serious injuries.
NOTICE Cause/situation If necessary, consequences of non-compliance (if applicable) ▶ Action/note	This symbol alerts you to situations which may result in damage to property.

2.2 Symbols

Symbol	Description
	The Laser Radiation symbol is used to alert the user to the danger of exposure to hazardous visible laser radiation when using the system. The laser is a class 3B radiation product.
	The High Voltage symbol that alerts people to the presence of electric potential large enough to cause injury or damage. In certain industries, high voltage refers to voltage above a certain threshold. Equipment and conductors that carry high voltage warrant special safety requirements and procedures.
	Protective Earth (PE). A terminal which is bonded to conductive parts of equipment for safety purposes and is intended to be connected to an external protective earthing system.
	The Ex mark signals to Authorities Having Jurisdiction and end-users in Europe that the product complies with the essential ATEX Directive for explosion protection.
	The UKCA Marking indicates conformity with health, safety, and environmental protection standards for products sold within the United Kingdom.
	The FCC mark indicates that the electromagnetic radiation from the device is below the limits specified by the Federal Communications Commission and the manufacturer has followed the requirements of the Supplier's Declaration of Conformity authorization procedures.
	The CSA Certification Mark indicates that the product was tested against and met the applicable North American standards requirements.
	The CE Marking indicates conformity with health, safety, and environmental protection standards for products sold within the European Economic Area (EEA).

2.3 U.S. export compliance

The policy of Endress+Hauser is strict compliance with U.S. export control laws as detailed in the website of the [Bureau of Industry and Security](#) at the U.S. Department of Commerce.

2.4 Labels

2.4.1 Nameplate

Analyzer-specific information, approvals, and warnings are listed on these labels in the blank areas shown below.

Warning: DO NOT OPEN IN AN EXPLOSIVE ATMOSPHERE is listed on all nameplates.

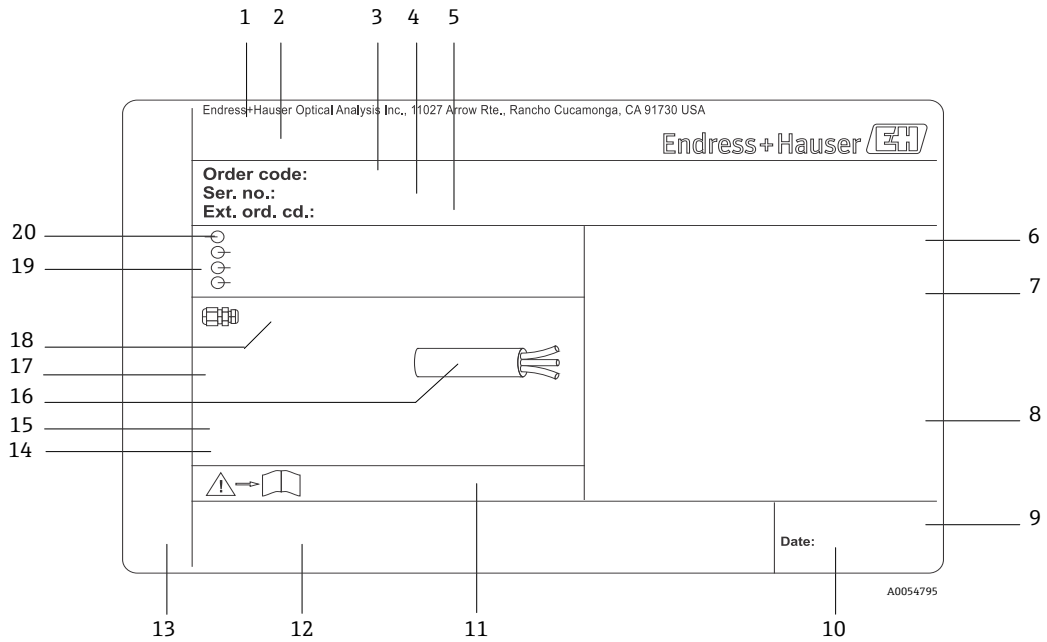

Figure 1. J22 TDLAS gas analyzer nameplate template

#	Description
1	Manufacturing name and location
2	Product name
3	Order code
4	Serial number (SN)
5	Extended order code
6	Degree of protection
7	Space for approvals for use in hazardous areas, certificate numbers, and warnings
8	Electrical connection data: available inputs and outputs
9	2-D matrix code (serial number)
10	Manufacturing date: year-month

#	Description
11	Document number of safety-related supplementary documentation
12	Space for approval markings (e.g., CE mark)
13	Space for degree of protection of connection and electronics compartment when used in hazardous areas
14	Space for additional information (special products)
15	Permitted temperature range for cable
16	Permitted ambient temperature (Ta)
17	Information on cable gland
18	Cable entry
19	Available inputs and outputs, supply voltage
20	Electrical connection data: supply voltage

2.4.2 Controller

POWER
 Nicht unter Spannung offen
 Do not open when energized
 Ne pas ouvrir sous tension

Terminate power prior to accessing equipment to prevent damage to the analyzer.

Warning: DO NOT OPEN IN
 EXPLOSIVE ATMOSPHERE
 Attention: NE PAS OUVRIR EN
 ATMOSPHERE EXPLOSIVE

Use caution before opening the analyzer enclosure to avoid injury.

2.4.3 Laser safety

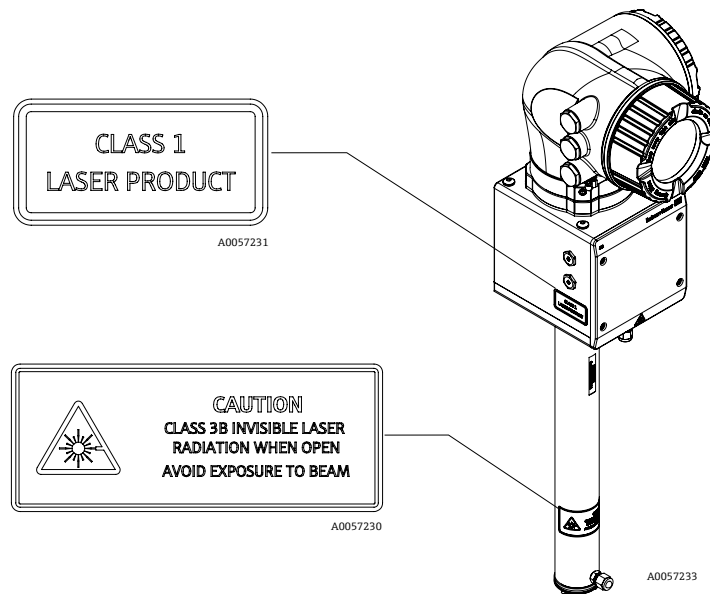

Fig 2. Location of laser safety labels

2.5 Personnel qualifications

Personnel must meet the following conditions for mounting, electrical installation, commissioning and maintenance of the device. This includes, but is not limited to:

- Be suitably qualified for their role and the tasks they perform
- Be trained in explosion protection
- Be familiar with national and local regulations and guidelines (e.g., CEC, NEC and/or ATEX/IECEX/UKEX)
- Be familiar with lockout/tagout procedures, toxic gas monitoring protocols and personal protective equipment (PPE) requirements

2.5.1 General

- Adhere to all warning labels to prevent damage to the unit.
- Do not operate the device outside the specified electrical, thermal and mechanical parameters.
- Only use the device in media to which the wetted materials have sufficient durability.
- Modifications to the device can affect the explosion protection and must be carried out by staff authorized to perform such work by Endress+Hauser.
- Only open the controller cover if the following conditions are met:
 - An explosive atmosphere is not present.
 - All device technical data is observed (see nameplate).
 - The optional stainless steel label tag is not bonded to earth. The maximum average capacitance of the tag determined by measurement is maximum 30 pF. This must be considered by the user to determine suitability of the equipment in a specific application.
- In potentially explosive atmospheres:
 - Do not disconnect any electrical connections while the equipment is energized.
 - Do not open the connection compartment cover when energized or the area is known to be hazardous.
- Install the controller circuit wiring according to the Canadian Electrical Code (CEC) respective National Electrical Code (NEC) using threaded conduit or other wiring methods in accordance with articles 501 to 505, and/or IEC 60079-14.
- Install the device according to the manufacturer's instructions and regulations.
- The flameproof joints of this equipment are other than the minimums specified in IEC/EN 60079-1 and must not be repaired by the user.

⚠ WARNING

Substitution of components is not permitted.

- ▶ Substitution of components may impair intrinsic safety.

2.6 Equipment training

Refer to local service providers for installation and operational training of the J22 TDLAS gas analyzer.

2.7 Potential risks affecting personnel

This section addresses the appropriate actions to undertake when faced with hazardous situations during or before service of the analyzer. It is not possible to list all potential hazards within this document. The user is responsible for identifying and mitigating any potential hazards present when servicing the analyzer.

NOTICE

- ▶ Technicians are expected to be trained and follow all safety protocols that have been established by the customer in accordance with the area hazard classification to service or operate the analyzer. This may include, but is not limited to, toxic and flammable gas monitoring protocols, lockout/tagout procedures, the use of PPE requirements, hot work permits and other precautions that address safety concerns related to the use and operation of process equipment located in hazardous areas.

2.7.1 Electrocuting hazard

1. Shut off power at the main disconnect external to the analyzer.

WARNING

- ▶ Complete this action before performing any service that requires working near the main input power or disconnecting any wiring or other electrical components.
2. Only use tools with a safety rating for protection against accidental contact with voltage up to 1000V (IEC 900, ASTF-F1505-04, VDE 0682/201).

2.7.2 Laser safety

The J22 TDLAS gas analyzer is a Class 1 laser product, which poses no threat to equipment operators. The laser internal to the analyzer controller is classified Class 3B and could cause eye damage if the beam is viewed directly.

WARNING





- ▶ Before servicing, shut off all power to the analyzer.

2.8 Analyzer technical specifications



Technical specifications are provided in the following tables that outline recommended equipment settings, ratings, and physical specifications.

Electrical and communications		
Input voltages	100 to 240 VAC, tolerance $\pm 10\%$, 50/60 Hz, 10W ¹ 24 VDC tolerance $\pm 20\%$, 10W UM = 250 VAC Heater 100 to 240, VAC tolerance $\pm 10\%$ 50/60 Hz, 80W	
Output type	Modbus RS485 or Modbus TCP over Ethernet (IO1)	U _N = 30 VDC U _M = 250 VAC N = nominal M = maximum
	Relay Output (IO2 and/or IO3)	U _N = 30 VDC U _M = 250 VAC I _N = 100 mA DC/500 mA AC
	Configurable IO Current 4-20 mA Input/Output (Passive/Active) (IO2 and/or IO3)	U _N = 30 VDC U _M = 250 VAC
	Intrinsically Safe Output (Flow Switch)	U _o = ± 5.88 V I _o = 4.53 mA P _o = 6.6 mW C _o = 43 μ F L _o = 1.74 H

¹ Transient over-voltages according to Over Voltage Category II.

Application data	
Environmental temperature range	Storage (analyzer and analyzer on panel): -40 °C to 60 °C (-40 °F to 140 °F) Storage (analyzer with enclosed sample conditioning system): -30 °C to 60 °C (-22 °F to 140 °F) Operation: -20 °C to 60 °C (-4 °F to +140 °F)
Environmental relative humidity	80 % to temperatures up to 31 °C decreasing linearly to 50 % RH at 40 °C
Environment: pollution degree	Rated Type 4X and IP66 for outdoor use and considered pollution degree 2 internally
Altitude	Up to 2000 m
Sample inlet pressure (SCS)	140 to 310 kPaG (20 to 45 psi)
Measurement ranges (H ₂ O)	0 to 500 ppmv (0 to 24 lb/mm scf) 0 to 2000 ppmv (0 to 95 lb/mm scf) 0 to 6000 ppmv (0 to 284 lb/mm scf)
Sample cell operating pressure range	Application dependent 800 to 1200 mbara (standard) 800 to 1700 mbara (optional)
Sample cell tested pressure range	-25 to 689 kPa (-7.25 to 100 psig)
Sample process temperature	-20 °C to 60 °C (-4 °F to 140 °F)
Sample flow rate	0.5 to 1.0 slpm (1 to 2 scfh)
Bypass flow rate	0.5 to 1.0 slpm (1 to 2 scfh)
Process seal	Dual Seal without Annunciation
Application data	
Primary process seal 1 ²	UV Grade Fuse Silica Glass
Primary process seal 2 ²	Primary Process Seal 2 ²
Secondary process seal ²	Elastosil RT 622
Area classification	
J22 TDLAS gas analyzer	cCSAus: Ex db ia [ia Ga] op is IIC T4 Gb Class I, Zone 1, AEx db ia [ia Ga] op is IIC T4 Gb Class I, Division 1, Groups A, B, C, D, T4 Tambient = -20 °C to 60 °C  II 2G ATEX/IECEX/UKEX:  II 2G Ex db ia [ia Ga] ib op is IIC T4 Gb Tambient = -20 °C to 60 °C
J22 TDLAS gas analyzer with sample conditioning system on panel	cCSAus: Ex db ia op is IIC T4 Gb Class I, Zone 1, AEx db ia op is IIC T4 Gb Class I, Division 1, Groups A, B, C, D, T4 Tambient = -20 °C to 60 °C  II 2G ATEX/IECEX/UKEX:  II 2G Ex db ia ib op is h IIC T4 Gb Tambient = -20 °C to 60 °C

² See [J22 Analyzer Seals](#) → .

J22 TDLAS gas analyzer with enclosed sample conditioning system	<p>cCSAus: Ex db ia op is IIC T4 Gb Class I, Zone 1, AEx db ia op is IIC T4 Gb Class I, Division 1, Groups A, B, C, D, T4 Tambient = -20 °C to 60 °C</p> <p>ATEX/IECEX/UKEX:  II 2G Ex db ia ib op is h IIC T4 Gb Tambient = -20 °C to 60 °C</p>
J22 TDLAS gas analyzer with enclosed sample conditioning system, with heater	<p>cCSAus: Ex db ia op is IIC T3 Gb Class I, Zone 1, AEx db ia op is IIC T3 Gb Class I, Division 1, Groups B, C, D, T3 Tambient = -20 °C to 60 °C</p> <p>ATEX/IECEX/UKEX:  II 2G Ex db ia ib op is h IIC T3 Gb Tambient = -20 °C to 60 °C</p>
Ingress protection	Type 4X, IP66

2.8.1 J22 Analyzer Seals

The optical head of the analyzer interfaces with the process medium through a lens and pressure transducer in the cell tube assembly. The lens and pressure transducer are considered to be the primary seals of the equipment. The ISEM interface module assembly provides separation between the transmitter head and optical head, which is considered to be the analyzer's secondary seal. Although the J22 contains other seals to prevent the migration of process medium into the electrical wiring system, if either of the primary seals fail only the ISEM interface module assembly is considered a secondary seal.

The J22 analyzer transmitter housing is certified for Class I, Division 1 with a factory-sealed terminal compartment which eliminates the need for external seals. The factory seal is only required when used in -40 °C (-40 °F) or lower ambient temperatures.

All optical heads for J22 analyzers systems were assessed as "Dual Seal without Annunciation" devices. Refer to the markings on the label for the maximum working pressures.

J22 gas analyzers with enclosed sample conditioning system with an optional heater require a suitable equipment certified seal to be installed within 5 cm (2 in) of the outer enclosure wall of the heating circuit.

For Class I Zone 1, installation seals are required within 5 cm (2 in) of the analyzer transmitter housing. If the J22 analyzer includes a heated enclosure, a suitable equipment certified seal must be installed within 5 cm (2 in) of the outer enclosure wall of the heating circuit as well.

2.8.2 Electrostatic discharge

The coating and the adhesive label are nonconducting and may generate an ignition capable level of electrostatic discharge under certain extreme conditions. The user should ensure that the equipment is not installed in a location where it may be subjected to external conditions, such as high-pressure steam, which may cause a buildup of electrostatic charges on nonconducting surfaces. To clean the equipment, use only a damp cloth.

2.8.3 Chemical compatibility

Never use vinyl acetate or acetone or other organic solvents to clean the analyzer housing or labels.

3 Installation

⚠ CAUTION

The safety of the analyzer is the responsibility of the installer and the organization they represent.

- ▶ Use appropriate protective safety equipment as recommended by local safety codes and practices (e.g., hard hat, steel-toe shoes, gloves, etc.) and exercise caution particularly when installing equipment at a height (i.e., one (1) meter above ground).

3.1 Lifting and moving the analyzer

The analyzer should be lifted or moved by a minimum of two individuals.

Never lift the analyzer by the controller enclosure or conduit runs, cable glands, cables, tubing or any other part protruding through the enclosure wall or edge of the panel or enclosure. Always carry the load using the following points/method shown under *Mounting the analyzer* → .

3.2 Mounting the analyzer

Mounting the J22 is based on the style of analyzer. When ordered without a sample conditioning system, the J22 may be specified with an optional mounting plate for installation. When specified with a sample conditioning system the analyzer may be wall or post-mounted.

When mounting the analyzer, be sure to position the instrument so that it is not difficult to operate adjacent devices. Refer to the layout diagrams mounting dimensions and additional instructions in the *J22 TDLAS gas analyzer Operating Instructions* (BA02152C).

3.2.1 Wall mounting

Tools and hardware

- Mounting hardware
- Spring nuts
- Machine screws and nuts to fit the size of the mounting hole

NOTICE

The J22 analyzer is designed for operation within the specified ambient temperature range. Intense sun exposure in some areas may impact the temperature inside the analyzer controller.

- ▶ Installing a sunshade or canopy over the analyzer for outdoor installations in cases where the rated temperature range could be exceeded is recommended.
- ▶ Hardware used for mounting the J22 TDLAS gas analyzer must be able to support four times the weight of the instrument. Depending on your configuration, the analyzer weight can be approximately 16 kg (36 lb) to 43 kg (95 lb).

To install the J22 on a wall

1. Install the bottom two mounting bolts to the mounting frame or wall. Do not fully tighten the bolts. Leave approximately 10 mm (3/8 in) gap to slide the analyzer mounting tabs onto the bottom bolts.
2. Lift the analyzer vertically at the points shown in the figure below.

⚠ CAUTION

- ▶ Distribute the weight evenly among personnel to avoid injury.

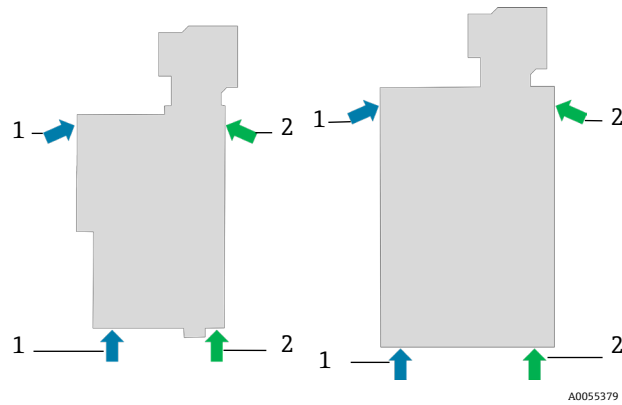

Fig 3. J22 lifting positions for panel (left) and enclosure (right) installations

#	Description
1	Person 1 hand positions
2	Person 2 hand positions

3. Lift the analyzer onto the bottom bolts and slide the slotted bottom mounting tabs over the bolts. Allow the two bottom bolts to take the weight of the analyzer while stabilizing in a vertical orientation.

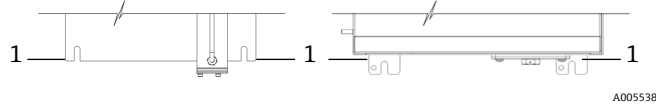

Fig 4. J22 slotted tab locations (1) for panel (left) and enclosure (right) mounts

4. Tilt the analyzer and push it towards the mounting frame or wall while aligning the two top bolts.
5. While one person exerts the necessary pressure to hold the analyzer to the frame or wall, the second person secures the two top bolts.
6. Tighten all four bolts.

3.2.2 Plate mounting

The plate mounting option is designed for users who will install the J22 analyzer within their own enclosure. The J22 should be installed vertically with the analyzer controller exposed to the exterior of the enclosure.

Tools and hardware

- Mounting hardware (supplied with plate)
- Gasket (supplied with plate)

To install the J22 on a plate

1. Refer to mounting plate dimensions in the *J22 TDLAS gas analyzer Operating Instructions (BA02152C)* to provide a proper cutout in the user-supplied enclosure.
2. Lower the analyzer through the enclosure hole so the plate aligns with the gasket.
3. Secure the analyzer in place with eight M6 x 1.0 screws and corresponding nuts. Tighten to a minimum 13 Nm (115 lbf-in).

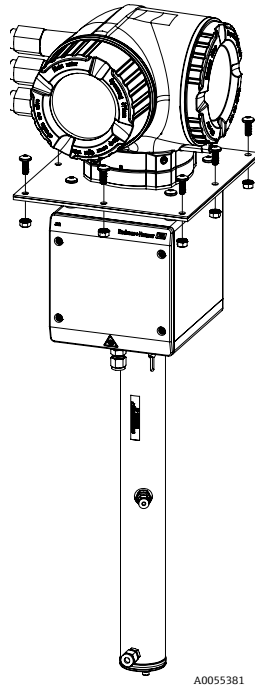

Fig 5. J22 plate mounting bracket and hardware

3.3 Opening and closing the analyzer enclosure

⚠ WARNING

Hazardous voltage and risk of electric shock.

- ▶ Failure to properly ground the analyzer may create a high-voltage shock hazard.

3.4 Protective chassis and ground connections

Before connecting any electrical signal or power, the protective and chassis grounds must be connected.

- Protective and chassis grounds must be of equal or greater size than any other current-carrying conductors, including the heater located in the sample conditioning system
- Protective and chassis grounds to remain connected until all other wiring is removed
- Protective grounding wire current carrying capacity must be at minimum the same as the main supply
- Earth bonding/chassis ground must be at least 6 mm² (10 AWG)

3.4.1 Protective ground cable

- Analyzer: 2.1 mm² (14 AWG)
- Enclosure: 6 mm² (10 AWG)

The grounding impedance must be less than 1 Ω.

3.4.2 Ground connections

Analyzer

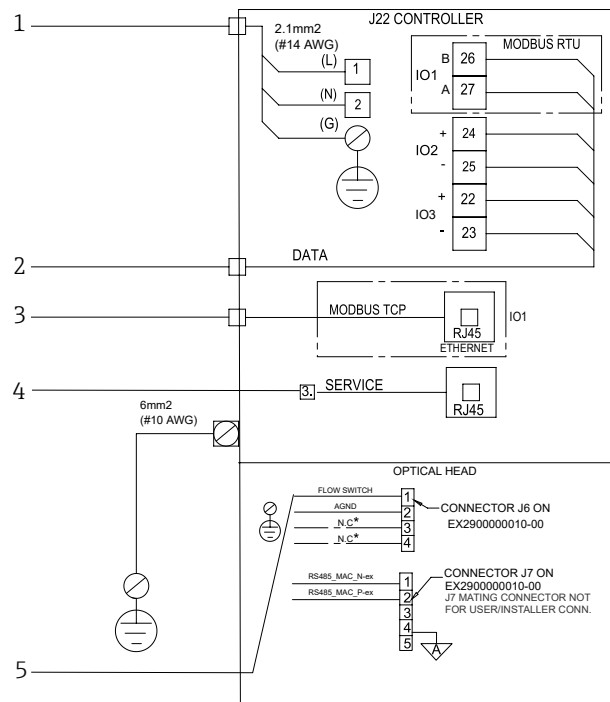

A0055382

Fig 6. J22 analyzer electrical connections

#	Description	#	Description
1	AC 100 to 240 VAC ±10 %; DC 24 VDC ±20 %	4	Connection to the Service port must only be permitted temporarily by trained personnel for test, repair or overhaul of the equipment, and if the area where the equipment is installed is known to be non-hazardous
2	IO options: Modbus RTU, 4-20 mA/Status out, Relay	5	Flow switch connection
3	10/100 Ethernet (optional), Network option Modbus TCP		

Enclosure, sample conditioning system

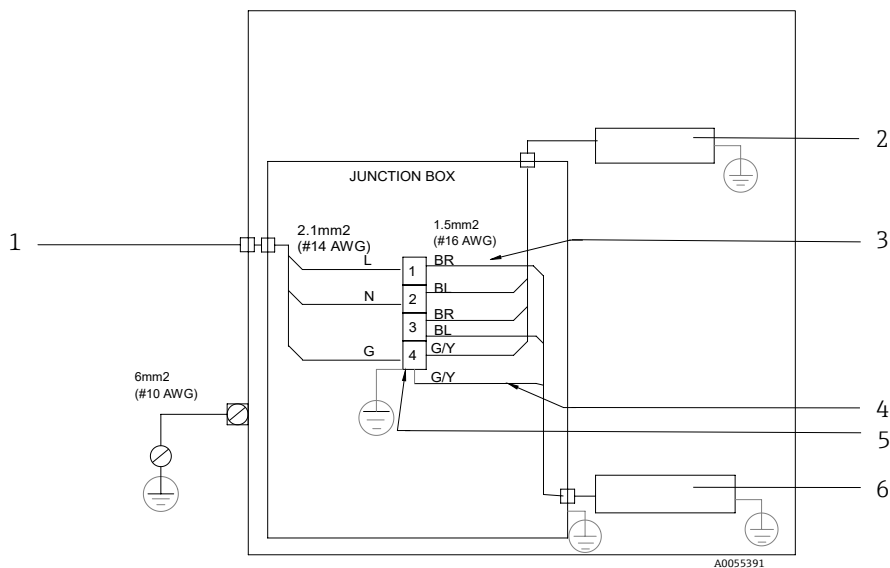

A0055391

Fig 7. J22 SCS enclosure electrical connections

#	Description
1	100 to 240 VAC \pm 10 %, 50/60 HZ; main power
2	Heater
3	Blue wire is used in thermostat phase, no ground wire
4	Ground wire is not installed for CSA thermostat. Only applies to ATEX version.
5	Use copper wire only

#	Description
6	Thermostat
BL	Blue wire
BR	Brown wire
G/Y	Green/yellow wire

3.5 Electrical wiring requirements

NOTICE

The installer is responsible for complying with all local installation codes.

- ▶ Field wiring (power and signal) must be accomplished using wiring methods approved for hazardous locations as per the Canadian Electrical Code (CEC) Appendix J, the National Electric Code (NEC) Article 501 or 505 and IEC 60079-14.
- ▶ Use copper conductors only.
- ▶ For models of the J22 TDLAS gas analyzer with SCS mounted within an enclosure, the inner sheath of the supply cable for the heater circuit must be sheathed with thermoplastic, thermosetting, or elastometric material. It must be circular and compact. Any bedding or sheath must be extruded. Fillers, if any, must be non-hygroscopic.
- ▶ The minimum length of the cable must exceed 3 m (9.8 ft).

3.5.1 Wire temperature rating and torque

- -40 to 105 °C (-40 to 221 °F)
- Terminal block screw torque: 1.2 Nm (10 lbf-in)

3.5.2 Cable entries

After installing all interconnecting wiring or cabling, make sure any remaining conduit or cable entries are plugged with certified accessories according to the intended use of the product.

Thread lubricant must be applied on all conduit hub threaded connections. Using Syntheses Glep1 or equivalent lubricant on all conduit screw thread is recommended.

NOTICE

- ▶ Conduit seals and glands specific to the application should be used where appropriate in compliance with local regulations.
- ▶ Models of the J22 TDLAS gas analyzer with enclosed SCS featuring an optional heater, a suitable equipment seal must be installed within 5 cm (2 in) of the outer enclosure wall of the heating circuit.

The J22 TDLAS gas analyzer transmitter enclosure approved for Class I Division 1 is identified as a factory seal device; installation of an additional seal is not required. In Class I Zone1 installations, seals are required within 5 cm (2 in) of the controller and heater connections.

3.5.3 Threaded entries

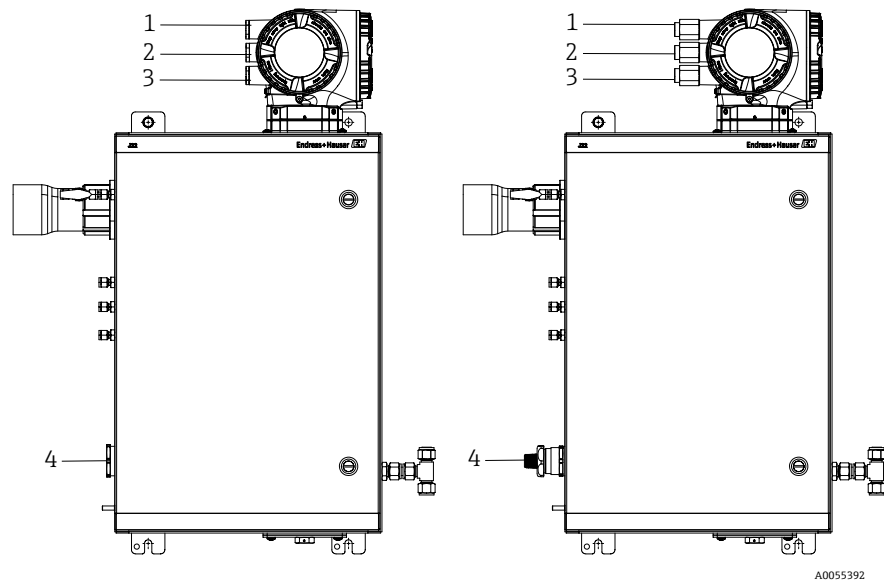

Fig 8. J22 threaded entries for enclosure for ATEX (left) and imperial (right) connections

Cable Entry	Description	ATEX, IECEx, INMETRO	Optional imperial connections
1	Controller power	M20 x 1.5	½" NPTF
2	Modbus output	M20 x 1.5	½" NPTF
3	(2) Configurable IO (IO2, IO3)	M20 x 1.5	½" NPTF
4	Heater power	M25 x 1.5	½" NPTM

Threaded entry locations for the panel configuration are the same as shown for the enclosed sample system above.

3.5.4 Cables type

The standard ANSI/TIA/EIA-568-B.2 Annex specifies CAT5 as the minimum used for Ethernet/IP. CAT5e and CAT 6 are recommended.

3.6 IS flow switch connection requirements

The J22 TDLAS gas analyzer can be offered with a variable flow meter equipped with an optional mechanical display and reed contact to measure the volume flow of flammable and non-flammable gases. See electrical parameters in *Analyzer Technical Specifications* →

3.6.1 Conditions of use

Installation must be in accordance with the National Electric Code NFPA 70, Article 500 to 505, ANSI/ISA-RP 12.06.01, IEC 60079-14 and Canadian Electrical Code (CEC) Appendix J for Canada.

The maximum temperature of terminals, cable glands and wires should be greater than 60 °C (140 °F) dependent of ambient and product temperature. The variable area flow meter with coated parts must be installed and maintained such that the risk of electrostatic discharge is minimized.

3.7 Connection values: signal circuits

3.7.1 Terminal assignment

Input supply voltage		Input/output 1		Input/output 2		Input/output 3	
1 (+)	2 (-)	26 (B)	27 (A)	24 (+)	25 (-)	22 (+)	23 (-)
		Modbus RS485 only ³		Device-specific terminal assignment: refer to adhesive label on terminal cover			

3.7.2 Safety-related values

Refer to *Analyzer technical specifications* → .

3.7.3 Modbus interface cable specification

Cable type	A
Characteristic impedance	135 to 165Ω at a measuring frequency of 3 to 20 MHz
Cable capacitance	< 30 pF/m
Wire cross-section	> 0.34 mm ² (22 AWG)
Cable type	Twisted pairs
Loop resistance	≤ 110Ω/km

3.8 Electrical circuit breakers

The main electronic assembly must be protected by an overcurrent protection rated for 10 amp or less.

NOTICE

The breaker must not interrupt the protective earth conductor.

- ▶ If the breaker in the customer-provided power distribution panel or switch is the primary means of disconnecting the power from the analyzer, locate the analyzer so that the power distribution panel is in close proximity to the equipment and within easy reach of the operator.

3.9 Connecting the gas supply

Consult the layout and flow diagrams in the system drawings in the Operator's Manual for supply and return port locations. All work must be performed by technicians qualified in pneumatic tubing.

⚠ WARNING

Process samples may contain hazardous material in potentially flammable or toxic concentrations.

- ▶ Personnel should have a thorough knowledge and understanding of the physical properties and safety precautions for the sample contents before connecting the gas supply.

3.10 Sample system heater

The purpose of the optional heater is to maintain the temperature of the sample system to avoid condensation in cold weather.

Manufacturer	Intertec
Power	AC 100 to 240 V tolerance ±10 %, 50/60 Hz, 80W
Ingress Protection	IP 68

³ Terminals 26 and 27 are replaced by an RJ45 connector for Modbus TCP/IP.

4 Equipment operation

CAUTION

- ▶ The safety of the analyzer is the responsibility of the installer and the organization they represent.
- ▶ Mounting hardware used for wall-mounting the J22 must be able to support four times the weight of the analyzer. Depending on your configuration, analyzer weight can range from approximately 19 kg (40 lb) to 43 kg (95 lb).

4.1 Operating controls

The J22 is operated using the optical touch pad. Basic operating parameters are provided in the *Operating Instructions* (BA02152C).

4.2 Commissioning

1. Power the system on.
2. Set flow rates and pressure for system as specified in the system drawings provided in the *Operating Instructions*.
3. Ensure sample vent has an unrestricted connection to atmosphere or flare, as specified.

NOTICE

- ▶ The temperature of the process medium must be within the ambient temperature rating of the equipment.
- ▶ Do not exceed specified pressure setting or equipment damage may occur.

4.3 Decommissioning

4.3.1 Intermittent operation

If the analyzer will be stored or shut down for a short time period, follow the instructions for isolating the measurement cell and sample conditioning system (SCS).

1. Purge the system:
 - a. Shut off the process gas flow.
 - b. Allow all residual gas to dissipate from the lines.
 - c. Connect a nitrogen (N₂) purge supply, regulated to the specified sample supply pressure, to the sample supply port.
 - d. Confirm that any valves controlling the sample flow effluent to the low-pressure flare or atmospheric vent are open.
 - e. Turn on the purge supply to purge the system and clear any residual process gases.
 - f. Turn off the purge supply.
 - g. Allow all residual gas to dissipate from the lines.
 - h. Close all valves controlling the sample flow effluent to the low-pressure flare or atmospheric vent.
2. Disconnect electrical connections to the system:
 - a. Disconnect power to the system.

CAUTION

- ▶ Confirm the power source is disconnected at the switch or circuit breaker. Make sure the switch or breaker is in the "OFF" position and locked with a padlock.
- b. Confirm all digital/analog signals are turned off at the location from which they are being monitored.
 - c. Disconnect the phase and neutral wires from the analyzer.
 - d. Disconnect the protective ground wire from the analyzer system.
3. Disconnect all tubing and signal connections.
 4. Cap all inlets and outlets to prevent foreign material such as dust or water from entering the system.
 5. Ensure the analyzer is free from dust, oils or any foreign material. Follow instructions found in "To clean the J22 exterior".
 6. Pack the equipment in the original packaging in which it was shipped, if available. If the original packaging material is no longer available, the equipment should be adequately secured (to prevent excessive shock or vibration).
 7. If returning the analyzer to the factory, complete the Decontamination Form provided by Endress+Hauser and attach to the outside of the shipping package as instructed before shipping. Refer to *Service* → .

5 Maintenance and service

Any repairs carried out by the customer or on behalf of the customer must be recorded in a site dossier and kept available for inspectors. For more information on system repairs and replacements, see the *Operating Instructions* (BA02152C).

WARNING

Process samples may contain hazardous material in potentially flammable or toxic concentrations.

- ▶ Personnel should have a thorough knowledge and understanding of the physical properties and safety precautions for the sample contents before connecting the gas supply.

5.1 Cleaning and decontamination

To clean the J22 exterior

The housing should be cleaned only with a damp cloth to avoid electrostatic discharge.

NOTICE



- ▶ Never use vinyl acetate, acetone, or other organic solvents to clean the analyzer housing or labels.

5.2 Troubleshooting and repairs

5.2.1 Cleaning the cell mirror

If contamination makes its way into the cell and accumulates on the internal optics, a **DC spectrum power range exceeded** fault results. If mirror contamination is suspected, contact Service before attempting to clean the mirrors. If advised to do so, use the following procedure. Carefully review the notices and warnings below.

NOTICE

- ▶ This procedure should be used **ONLY** when necessary and is not part of routine maintenance. To avoid compromising the system warranty, contact Service →  before cleaning mirrors.
- ▶ Do NOT clean the top mirror. If the top mirror is visibly contaminated or scratched in the clean area (see mirror figure below), refer to Service → .
- ▶ Cell assembly mirror cleaning should only be performed when there is a small amount of contamination. Otherwise, refer to Service → .
- ▶ Careful marking of the mirror orientation is critical to restoring system performance upon reassembly after cleaning.
- ▶ Always handle the optical assembly by the edge of the mount. Never touch coated surfaces of the mirror.
- ▶ Pressurized gas duster products are not recommended for cleaning components. The propellant may deposit liquid droplets onto the optic surface.
- ▶ Never rub an optical surface, especially with dry tissues, as this can mar or scratch the coated surface.
- ▶ This procedure should be used **ONLY** when necessary and is not part of routine maintenance.

WARNING



INVISIBLE LASER RADIATION

The sample cell assembly contains a low power, 35 mW maximum, CW Class 3B invisible laser with a wavelength between 750 to 3000 nm.

- ▶ Never open the sample cell flanges or the optical assembly unless the power is turned off.

WARNING

Process samples may contain hazardous material in potentially flammable and toxic concentrations.

- ▶ Personnel should have a thorough knowledge and understanding of the physical properties and safety precautions for the sample contents before operating the SCS.
- ▶ All valves, regulators, and switches should be operated in accordance with site lockout/tagout procedures.

The procedure for cleaning the cell assembly mirror is broken into 3 parts:

- Purging the SCS and removing the mirror assembly
- Cleaning the cell assembly mirror
- Replacing the mirror assembly and components

For analyzers without an Endress-provided sample conditioning system (SCS), refer to instructions provided with your sampling system and follow only the procedure for cleaning the cell assembly mirror.

Tools and materials

- Lens cleaning cloth (Cole-Parmer® EW-33677-00 Texwipe TX1009 Low-Particulate Wipes or equivalent)
- Reagent-grade isopropyl alcohol (Cole-Parmer® EW-88361-80 or equivalent)
- Small drop dispenser bottle (Nalgene® FEP drop-dispenser bottle or equivalent)
- Acetone-impenetrable gloves (Honeywell North CE412W Chemsoft Nitrile gloves or equivalent)

- Hemostat (Fisherbrand™ 13-812-24 Rochester-Pean Serrated Forceps or equivalent)
- Bulb blower or dry compressed air/nitrogen
- Torque wrench
- 3 mm Hex driver
- Non-outgassing grease
- Flashlight

To purge the SCS and remove the mirror assembly

1. Power down the analyzer.
2. Isolate the SCS from the process sample tap.
3. If possible, purge the system with nitrogen for 10 minutes.
4. On the underside of the SCS enclosure, remove the plate covering the measurement cell located inside the enclosure and set aside. Retain screws.

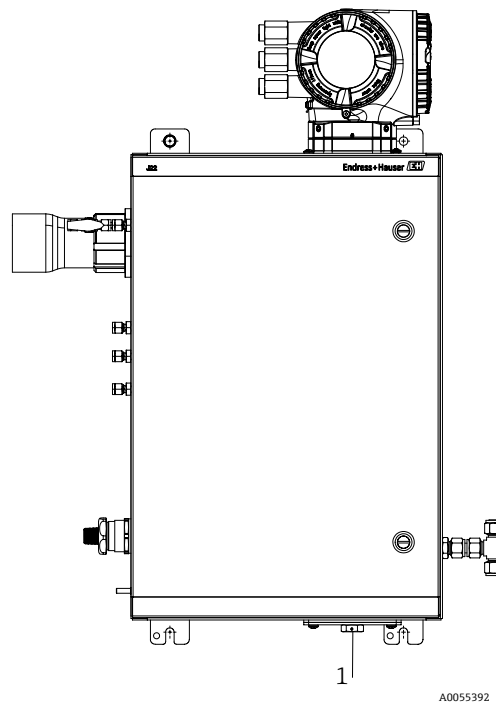

Fig 9. Measurement cell plate location (1)

5. Gently remove the mirror assembly from the cell by removing the 4 socket head cap screws and set the mirror on a clean, stable and flat surface.

To clean the cell assembly mirror

1. Examine the top window inside the sample cell. Ensure there is no contamination on the top window.
2. Using a bulb blower or dry compressed air/nitrogen, remove dust and other large particles of debris.
3. Put on clean acetone-impenetrable gloves.
4. Double fold a clean sheet of lens cleaning cloth and clamp near and along the fold with the hemostats or fingers to form a “brush.”
5. Place a few drops of isopropyl alcohol onto the mirror and rotate the mirror to spread the liquid evenly across the mirror surface.
6. With gentle, uniform pressure, wipe the mirror from one edge to the other with the cleaning cloth only once and only in one direction to remove the contamination. Discard the cloth.
7. Repeat with a clean sheet of lens cleaning cloth to remove the streak left by the first wipe.
8. Repeat step 6, if necessary, until there is no visible contamination in the required clean area of the mirror. In the figure below, the shaded ring shows the area of the mirror that must be clean and free of scratches.
If the mirror is not clean and free of scratches in the required area, replace the mirror assembly.

To replace the mirror assembly and components

1. Replace the O-ring and ensure it is properly seated.
2. Add a very thin layer of non-outgassing grease to the O-ring.
3. Carefully replace the mirror assembly onto the cell (it is not necessary to maintain the original orientation).
4. Tighten the socket head cap screws evenly with a torque wrench to 3.5 Nm (30 lbf-in).
5. Replace the plate on the outside of the SCS enclosure. Disregard this step for analyzers without an enclosed SCS.

5.2.2 Replacing the membrane separator filter

Make sure that a membrane separator filter is operating normally. If liquid enters the cell and accumulates on the internal optics, a **DC spectrum power range exceeded** fault will result.

To replace the membrane separator filter

1. Close the sample supply valve.
2. Unscrew the cap from the membrane separator.
3. Determine if the membrane filter is dry or if liquid/contaminants are present. Follow the appropriate steps below.

If the membrane filter is dry

6. Check if there are any contaminants or discoloring of the white membrane. If yes, the filter should be replaced.
7. Remove the O-ring and replace the membrane filter.
8. Replace the O-ring on top of the membrane filter.
9. Place the cap back onto the membrane separator and tighten.
10. Check upstream of the membrane for liquid contamination and clean and dry out before reopening the sample supply valve.

If liquid or contaminants are detected on the filter

3. Drain any liquids and clean with isopropyl alcohol.
4. Clean any liquids or contaminants from the base of the membrane separator.
5. Replace the filter and the O-ring.
6. Place the cap onto the membrane separator and hand tighten.
7. Check upstream of the membrane for liquid contamination and clean and dry out before reopening the sample supply valve.

5.2.3 Enclosure purge (optional)

The optional enclosure purge is typically elected when the sample gas contains high concentrations of H₂S. When maintenance of the J22 is required, follow one of the two methods described below prior to opening the enclosure door.

To purge the enclosure with a gas sensor

⚠ WARNING

- ▶ Ensure an appropriate sensor is used based on the toxic components in the process gas stream.
1. Allow the sample gas to continue flowing through the system.
 2. Open the tee fitting cap on the exhaust port on the lower right side of the enclosure and insert a sensor to determine if there is H₂S inside the enclosure.
 3. If no hazardous gas is detected, proceed with opening the enclosure door.
 4. If hazardous gas is detected, follow the instructions below for purging the enclosure.

To purge the enclosure without a gas sensor

1. Turn off the sample gas to the system.
2. Connect the purge gas to the purge inlet on the upper right side of the enclosure.
3. Open the exhaust on the bottom right side of the enclosure and connect a piece of tubing that vents to safe area.
4. Input the purge gas at 5 liters per minute (0.176 cfm).
5. Operate the purge for 22 minutes.

5.2.4 Sample system purge (optional)

1. Shut off gas to the analyzer.
2. Ensure the vent and bypass, if present, are open.
3. Connect the purge gas to 'sample purge in' port.
4. Switch the gas select valve from 'sample in' to 'purge in'.
5. Set the flow rate to 1 liter per minute and run the purge for at least 10 minutes for safety.

5.2.5 Repair verification

When repairs have been completed correctly, alarms will clear from the system.

⚠ CAUTION

Residual risk. Some capacitors may remain charged with high voltage in the case of a single fault.

- ▶ Allow 10 minutes before controller covers are opened.

5.2.6 Power termination covers

Confirm the termination cover is closed before initiating operation or after a repair event. Should the cover become damaged, it must be replaced to avoid potential safety risk.

5.3 Spare parts

All parts required for operation of the J22 TDLAS gas analyzer must be supplied by Endress+Hauser or an authorized agent. Refer to the *J22 TDLAS gas analyzer Operating Instructions* (BA02152C) for a complete list of available spare parts.

5.4 Service

For Service, refer to our website (<https://www.endress.com/contact>) for the list of local sales channels in your area.

www.addresses.endress.com
