

# Operating Instructions Off-Loading Flow Computer SBC600

Precision and efficiency in off-loading operations



## Revision history

Product version	Operating Instructions	Changes
5.00.xx	BA01909S/04/EN/01.18	Initial version
5.01.xx	BA01909S/04/EN/02.23	Appendix section: messages and Modbus data register specification amended.
5.02.xx	BA01909S/04/EN/03.24	Adjustments in the following sections: <ul style="list-style-type: none"> <li>▪ Section 4.2.1: Nameplate</li> <li>▪ Sections 7.2.1, 7.3.1, 7.3.2 and 7.3.7: Screenshots updated.</li> <li>▪ Section 8: Figure revised.</li> <li>▪ Section 10.1: Adjustments</li> <li>▪ Section 10.2: New structure, new sub-section 10.2.2, screenshot updated</li> <li>▪ Section 10.4: New structure, new sub-section 10.4.2, screenshot updated</li> <li>▪ Section 15.1: Messages list</li> <li>▪ Section 15.3.2: Modbus data register specification</li> <li>▪ Section 1.6 and Section 15.4: Windows XP is no longer supported</li> </ul>
5.03.xx	BA01909S/04/EN/04.24	Adjustments in the following sections: <ul style="list-style-type: none"> <li>▪ Section 15.1: Messages list</li> <li>▪ Section 15.3.2: Modbus data register specification</li> </ul>

## Table of contents

<b>1</b>	<b>About this document</b> . . . . .	<b>5</b>	7.2	Navigation . . . . .	20
1.1	Document function . . . . .	5	7.2.1	General screen layout . . . . .	20
1.2	Symbols . . . . .	5	7.3	Display screens and buttons . . . . .	20
1.2.1	Safety symbols . . . . .	5	7.3.1	Batch Control screen . . . . .	20
1.2.2	Symbols for certain types of information . . . . .	5	7.3.2	System Overview screen . . . . .	21
1.2.3	Electrical symbols . . . . .	6	7.3.3	Parameter screen . . . . .	22
1.2.4	Software symbols . . . . .	6	7.3.4	Settings screens . . . . .	23
1.3	Acronyms used . . . . .	6	7.3.5	Trends screen . . . . .	24
1.4	Valid versions . . . . .	7	7.3.6	Batch History screen . . . . .	25
1.5	Registered trademarks . . . . .	7	7.3.7	Batch History Details screen . . . . .	25
			7.3.8	Messages screen . . . . .	26
			7.3.9	Administration screen . . . . .	26
<b>2</b>	<b>Basic safety instructions</b> . . . . .	<b>8</b>	7.3.10	Diagnostic Information screen . . . . .	27
2.1	Requirements for personnel . . . . .	8	7.3.11	Messages Historical screen . . . . .	27
2.2	Designated use . . . . .	8	7.3.12	ZERO Verification screen . . . . .	28
2.3	Workplace safety . . . . .	8	7.3.13	Audit Trail screen . . . . .	29
2.4	Operational safety . . . . .	9	7.3.14	Show Keyboard button . . . . .	30
2.5	Product safety . . . . .	9	7.3.15	Display Off button . . . . .	30
2.6	IT security . . . . .	9	7.4	Valve control . . . . .	30
			7.5	Metering profiles . . . . .	31
			7.5.1	Metering profiles from the HMI operating panel . . . . .	31
<b>3</b>	<b>Product description</b> . . . . .	<b>10</b>	7.6	Special functions . . . . .	33
3.1	Product design . . . . .	10	7.6.1	Air Index warning . . . . .	33
3.1.1	System overview . . . . .	10			
3.1.2	Using the Off-Loading Flow Computer . . . . .	11	<b>8</b>	<b>System integration</b> . . . . .	<b>35</b>
3.1.3	Modifications to the Off-Loading Flow Computer . . . . .	11	<b>9</b>	<b>Commissioning</b> . . . . .	<b>36</b>
<b>4</b>	<b>Incoming acceptance and product identification</b> . . . . .	<b>12</b>	9.1	Change date and time . . . . .	36
4.1	Incoming acceptance . . . . .	12	9.2	Exporting the settings . . . . .	37
4.2	Product identification . . . . .	12	9.3	BMC Service Tool . . . . .	37
4.2.1	Control unit and operator terminal . . . . .	12	9.4	User administration . . . . .	37
4.2.2	Endress+Hauser system . . . . .	12	9.4.1	User levels . . . . .	38
4.3	Storage and transport . . . . .	13	9.4.2	Log in/log out . . . . .	38
			9.4.3	Access authorization . . . . .	38
<b>5</b>	<b>Installation</b> . . . . .	<b>14</b>	9.5	Relay outputs . . . . .	39
<b>6</b>	<b>Electrical connection</b> . . . . .	<b>17</b>	9.5.1	System status . . . . .	39
6.1	Connection conditions . . . . .	17	9.5.2	Custom warnings . . . . .	40
6.1.1	Required tools . . . . .	17	9.6	Modbus TCP Gateway (optional) . . . . .	40
6.1.2	Connecting cable . . . . .	17	<b>10</b>	<b>Operation</b> . . . . .	<b>41</b>
6.1.3	Ethernet connection . . . . .	17	10.1	Totalizing the transferred quantity . . . . .	41
6.1.4	Cable entries and distribution box . . . . .	17	10.2	Preparing for an off-loading operation . . . . .	41
6.2	Special connection instructions . . . . .	17	10.2.1	Manual operation . . . . .	41
			10.2.2	Operation via Modbus . . . . .	44
<b>7</b>	<b>Operation options</b> . . . . .	<b>19</b>	10.3	Editing the list of suppliers . . . . .	44
7.1	Starting up and shutting down . . . . .	19	10.4	Completing an off-loading operation . . . . .	45
7.1.1	Starting up . . . . .	19	10.4.1	Manual operation . . . . .	46
7.1.2	Shutting down . . . . .	19	10.4.2	Operation via Modbus . . . . .	47
			<b>11</b>	<b>Diagnostics and troubleshooting</b> . . . . .	<b>48</b>
			11.1	System status . . . . .	48

11.2	Messages . . . . .	48
11.2.1	Message categories . . . . .	48
11.2.2	Displaying currently active messages . . . . .	48
11.2.3	Acknowledge messages . . . . .	49
11.2.4	List of messages . . . . .	49
11.3	Ticket printer . . . . .	49
11.4	Broken wire signal . . . . .	49
11.5	Power failure . . . . .	50
11.6	Batch result too high . . . . .	50
<b>12</b>	<b>Maintenance . . . . .</b>	<b>51</b>
12.1	Ticket printer . . . . .	51
12.1.1	Replacing the paper roll . . . . .	51
12.1.2	Inserting the paper roll . . . . .	51
12.1.3	Cleaning . . . . .	52
12.1.4	Service and replacement . . . . .	53
12.2	Display on operating panel . . . . .	53
12.3	Cabinet fan . . . . .	53
12.4	System maintenance . . . . .	53
<b>13</b>	<b>Repair . . . . .</b>	<b>54</b>
13.1	General notes . . . . .	54
13.2	Spare parts and services . . . . .	54
<b>14</b>	<b>Technical data . . . . .</b>	<b>55</b>
14.1	Power supply . . . . .	55
14.2	Input/output . . . . .	55
14.3	Environment . . . . .	55
<b>15</b>	<b>Appendix . . . . .</b>	<b>56</b>
15.1	Messages list . . . . .	56
15.2	Sealing/locking . . . . .	65
15.2.1	Sealing program settings . . . . .	65
15.2.2	Sealing cabinets . . . . .	66
15.2.3	USB ports . . . . .	67
15.3	Interface specification . . . . .	68
15.3.1	Modbus TCP . . . . .	68
15.3.2	Modbus data register specification . . . . .	70
15.4	Information on the third-party software used . . . . .	79
15.4.1	Rockwell Factory Talk View – Site Edition and RSLinx . . . . .	79
15.4.2	Microsoft(R) Windows(R) Embedded Standard 7 . . . . .	80
15.4.3	MICROSOFT SQL SERVER 2008 R2 EXPRESS . . . . .	81
15.4.4	Comfort on-screen keyboard . . . . .	81

# 1 About this document

## 1.1 Document function

These Operating Instructions contain all the information required in the various life cycle phases of the device: from product identification, incoming acceptance and storage, to installation, connection, operation and commissioning, through to troubleshooting, maintenance and disposal.

## 1.2 Symbols

### 1.2.1 Safety symbols

#### **DANGER**

This symbol alerts you to a dangerous situation. Failure to avoid this situation will result in serious or fatal injury.

#### **WARNING**

This symbol alerts you to a potentially dangerous situation. Failure to avoid this situation can result in serious or fatal injury.













#### **CAUTION**

This symbol alerts you to a potentially dangerous situation. Failure to avoid this situation can result in minor or medium injury.





#### **NOTICE**

This symbol alerts you to a potentially harmful situation. Failure to avoid this situation can result in damage to the product or something in its vicinity.













### 1.2.2 Symbols for certain types of information

Symbol	Meaning
	<b>Permitted</b> Procedures, processes or actions that are permitted.
	<b>Preferred</b> Procedures, processes or actions that are preferred.
	<b>Forbidden</b> Procedures, processes or actions that are forbidden.
	<b>Tip</b> Indicates additional information.
	Reference to documentation
	Reference to page
	Reference to graphic
	Notice or individual step to be observed
	Series of steps
	Result of a step
	Help in the event of a problem
	Visual inspection

### 1.2.3 Electrical symbols

Symbol	Meaning
	Direct current
	Alternating current
	Direct current and alternating current
	<b>Ground connection</b> A grounded terminal which, as far as the operator is concerned, is grounded via a grounding system.
	<b>Potential equalization connection (PE: protective earth)</b> Ground terminals that must be connected to ground prior to establishing any other connections.  The ground terminals are located on the interior and exterior of the device: <ul style="list-style-type: none"> <li>▪ Interior ground terminal: potential equalization is connected to the supply network.</li> <li>▪ Exterior ground terminal: device is connected to the plant grounding system.</li> </ul>

### 1.2.4 Software symbols

Symbol	Meaning
	Error message
	Warning
	New message, not acknowledged
	Acknowledged message, but message is still active
	Acknowledged message, no longer active (cause has been rectified)
	<b>Acknowledged message:</b> Press this button to acknowledge the selected message.
	<b>Print:</b> Press this button to print out the list of messages (only if a printer is connected).
	<b>Refresh:</b> Press this button to update the list of messages.
	<b>Add:</b> This button is used to add more suppliers.
	<b>Pen:</b> This button is used to edit the selected entry.
	This button is used to delete the selected entry.
	This button is used to delete the last letter or digit.
	This button is used to delete the entire text.

## 1.3 Acronyms used

Acronyms	Meaning
API	American Petroleum Institute
BTN	Off-Loading Ticket Number
EMC	Electromagnetic Compatibility
GEP	Good Engineering Practices

Acronyms	Meaning
GMP	Good Manufacturing Practices
GMT/UTC	Greenwich Mean Time/Coordinated Universal Time
HMI	Human Machine Interface - software visualization application
IPA	Isopropyl Alcohol (isopropanol)
NIST	US National Institute of Standards and Technology
PLC	Programmable Logic Controller (PLC)
RTD	Resistance Temperature Detector
SBC600	Off-Loading Flow Computer
TCP	Transmission Control Protocol
UPS	Uninterruptible Power Supply
ZV	Zero Verification

## 1.4 Valid versions

*This user manual applies to the following versions:*

Component	Version
PLC program <sup>1)</sup>	From V5.02.xx
HMI program <sup>1)</sup>	From V5.02.xx
Hardware platform <sup>1)</sup>	From V1.02.xx

1) It applies to all types of cabinet installation (systems with just one or two cabinets)

## 1.5 Registered trademarks

FactoryTalk®, RSLinx®, Studio 5000™ and all other Rockwell Software® products are registered trademarks of Rockwell Automation.

Microsoft®, Windows 7®, Internet Explorer® and the Microsoft logo are registered trademarks of the Microsoft Corporation.

All other brand and product names are trademarks or registered trademarks of the companies and organizations in question.

## 2 Basic safety instructions

When installing, commissioning, diagnosing and maintaining the Off-Loading Flow Computer or other individual devices in the Off-Loading Metering System, it is absolutely essential to observe the safety instructions provided in the Operating Instructions for the specific devices and in the associated device documentation.

### 2.1 Requirements for personnel

The staff responsible for installation, commissioning, diagnosis and maintenance must meet the following requirements:

- They must be suitably qualified experts who have been trained by Endress+Hauser, or they must be experts from the Endress+Hauser service organization.
- The staff must be authorized by the ship owner/operator.
- The staff must be familiar with regional/national requirements and regulations.
- Prior to commencing work, the staff must have read and understood the instructions in these Operating Instructions and in the supplementary documentation and certificates (depending on the application).
- The staff must follow the instructions and comply with the basic requirements.

Operating personnel must meet the following requirements:

- The operating staff must be instructed and authorized according to the requirements of the task by the facility's owner/operator.
- The operating staff must follow the instructions contained in this manual.

### 2.2 Designated use

This user manual is aimed at **operators** and **supervisors** working with the Off-Loading Flow Computer. The functionalities described in this manual apply to users at **supervisor** level. Access for **operator** level users is slightly restricted.

The SBC600 has been designed for use with Endress+Hauser Promass Coriolis flowmeters, sizes DN80 to DN350. Any other use is considered to be non-designated use. The manufacturer is not liable for damage resulting from non-designated use; in such instances the user bears full responsibility. Designated use entails compliance with the operating and maintenance requirements specified by the manufacturer.

The SBC600 must be installed in a safe environment (not in hazardous areas or Ex zones).

The SBC600 must be installed in a dry, air-conditioned room.

### 2.3 Workplace safety

When working on or with components of the Off-Loading Flow Computer:

Always use personal protective equipment in accordance with regional/national requirements and specifications.

When working with wet hands on or with devices:

The wearing of gloves is recommended, as otherwise there is an increased risk of electric shock



## 2.4 Operational safety

- Operate the SBC600 and the complete Off-Loading Metering System in proper technical condition and fail-safe condition only
- The operator is responsible for the trouble-free operation of the complete Off-Loading Metering System including the SBC600 and the devices
- Repairs must only be performed by certified Endress+Hauser specialists
- Unauthorized modifications to the Off-Loading Flow Computer or the use of devices that are not permitted can lead to unforeseeable dangers:  
If modifications are nevertheless required, please contact the manufacturer
- Ensure continued operational safety and reliability:
  - Only carry out repairs if they are expressly permitted by the manufacturer
  - Observe all regional/national regulations regarding the repair of electrical devices.
  - Use only original spare parts and accessories from Endress+Hauser

## 2.5 Product safety

### Endress+Hauser components

The Off-Loading Flow Computer has been developed and certified in accordance with the company's product development standard. This includes the mechanical and electrical design, performance testing and impact assessment of environmental sustainability (e.g. climate, vibration, EMC) in accordance with the requirements of the OIML R117 standard.

### Program (software)

The application software was written by Endress+Hauser using the specified tools. We have adhered to the GMP and GEP as described in an Endress+Hauser standard for writing application software.

The software has been developed following a V-model based standardized process and has been certified to WELMEC 7.2.

## 2.6 IT security

We only provide a warranty if the device is installed and used as described in the Operating Instructions. The device is equipped with security mechanisms to protect it against any inadvertent changes to the device settings.

IT security measures in line with operators' security standards and designed to provide additional protection for the device and device data transfer must be implemented by the operators themselves.



The operator is responsible for data backup.

## 3 Product description

The principle functions of the Off-Loading Flow Computer are:

The main tasks of the Off-Loading Flow Computer include the recording and visualization of the off-loading data of all the devices involved. The Computer then creates off-loading metering tickets and metering profiles from these data.

Combined with the complete metering system for off-loading operations, the SBC600 provides the following functionalities:

- Continuous, bidirectional mass flow measurement using Coriolis flowmeters
- Compensation of entrained air
- Totalization of the quantity of transferred fuel
- Batch data storage
- Off-loading metering ticket printout
- Metering profiles
- Density display
- Volume display
- Fluid temperature measurement
- Line packing optimization using control valve (loading only)

### 3.1 Product design

The Off-Loading Flow Computer SBC600 is designed to create and issue off-loading metering tickets and metering profiles when connected to the relevant system components (devices). The system provides user-friendly, step-by-step procedures for measuring, monitoring and tracking off-loading operations.

Optionally, these data can be forwarded to the customer via a Modbus connection.

The SBC600 can be supplied with a choice of three cabinet configurations:

- Single cabinet with the PLC and HMI in the same cabinet (control unit) for wall mounting
- Two cabinets with the PLC (control unit) and HMI (operator terminal) in separate cabinets for wall mounting
- Two cabinets with the PLC (control unit) in one cabinet for wall mounting and the HMI (operator terminal) in a desk panel

This user manual applies for all the versions listed above.

#### 3.1.1 System overview

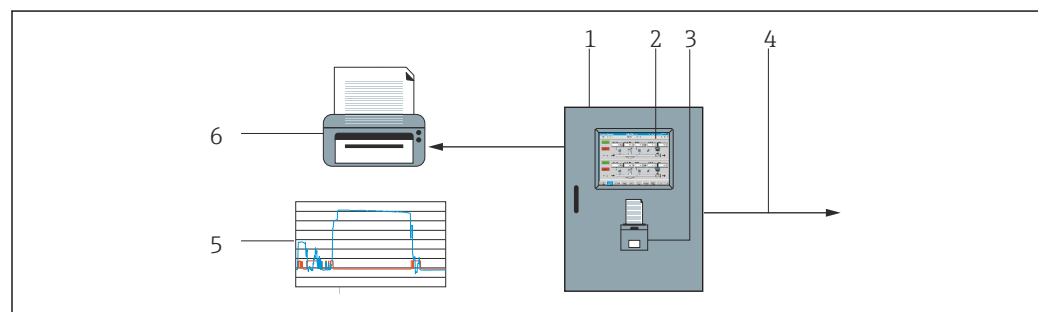

**1** Overview of the Off-Loading Flow Computer

- 1 Control unit and operator terminal of the Off-Loading Flow Computer SBC600
- 2 Integrated human-machine interface (HMI)
- 3 Integrated printer for off-loading metering tickets (BMT)
- 4 Modbus TCP (optional)
- 5 Metering profile
- 6 External printer to print out metering profiles (optional)

A complete Off-Loading Metering System is depicted in the picture below to provide a better understanding of the functionality of the SBC600.

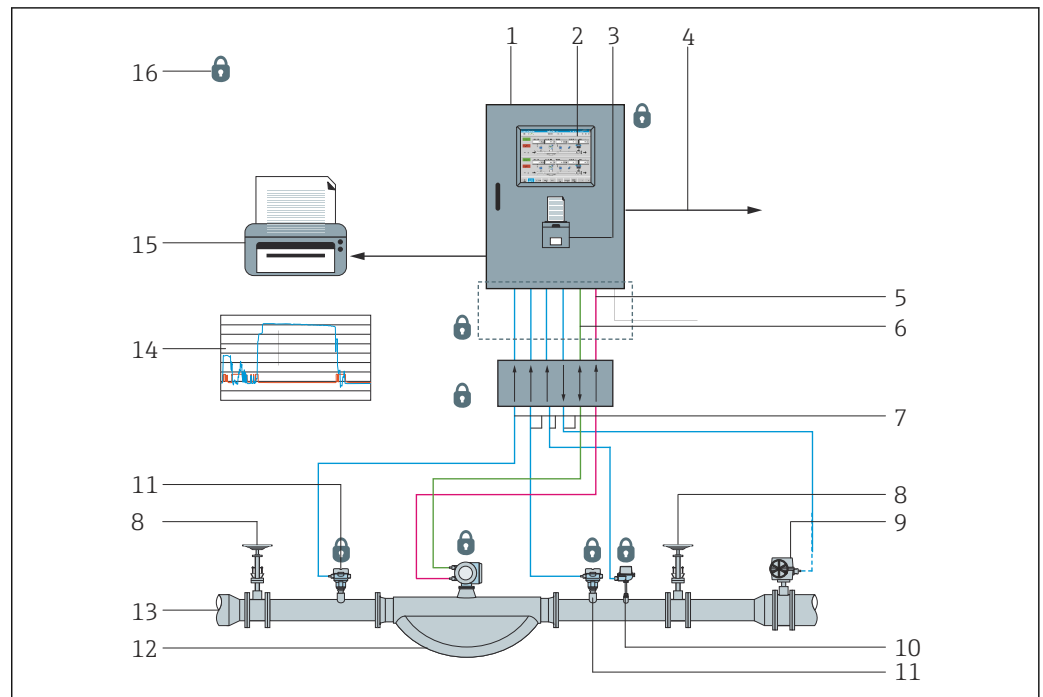

2 System design of the Off-Loading Metering System

- 1 Off-Loading Flow Computer SBC600
- 2 Integrated human-machine interface (HMI)
- 3 Integrated printers for off-loading metering tickets (BMT)
- 4 Modbus TCP (optional)
- 5 DC 24 V pulse
- 6 Modbus RTU
- 7 4 to 20 mA
- 8 Shut-off valve
- 9 Control valve
- 10 Temperature
- 11 Pressure
- 12 Flow
- 13 Metering line
- 14 Metering profile
- 15 External printer to print out metering profiles (optional)
- 16 Sealed system components

### 3.1.2 Using the Off-Loading Flow Computer

The Off-Loading Flow Computer may only be used if it has no technical defects and only in accordance with its designated use and in accordance with the instructions specified in this user manual. The SBC600 may be operated only by safety-conscious and suitably trained personnel who are fully aware of the risks involved.

### 3.1.3 Modifications to the Off-Loading Flow Computer

As it is a modular, high-precision measuring system, only suitably trained and qualified personal may make changes to the system. Modifications to the design of the hardware or software may be undertaken only by Endress+Hauser Process Solutions prior to the implementation of updates or upgrades.

All modifications must comply with the applicable certificate of the calibration authority. Otherwise, the certificate will lose its validity.

Contact your local Endress+Hauser Sales Center for more support.

## 4 Incoming acceptance and product identification

### 4.1 Incoming acceptance

Upon receipt of goods, check the following:

- Examine the packaging and contents for damage
- Check the delivery to ensure it is complete and matches the order

The documentation is included in the scope of delivery of the Off-Loading Flow Computer and comprises:

- These Operating Instructions for the Off-Loading Flow Computer SBC600
- Wiring diagram of the Off-Loading Flow Computer SBC600

### 4.2 Product identification

#### 4.2.1 Control unit and operator terminal

The control unit and the operator terminal can be identified using the nameplate which is located on every cabinet. The operator terminal can be accommodated in a separate cabinet or integrated in the cabinet of the control unit. The control unit nameplate is always attached. The operator terminal nameplate is only attached if an optional operator terminal is provided.

#### 4.2.2 Endress+Hauser system

You can identify the components in the following ways:

- Nameplate data
- Extended order code with breakdown of the device features on the delivery note
- Enter the serial number from the nameplate into *Device Viewer* ([www.endress.com/deviceviewer](http://www.endress.com/deviceviewer)): All the information on the system/device is displayed.
- Enter the serial number from the nameplate into the *Endress+Hauser Operations app* or use the *Endress+Hauser Operations app* to scan the 2-D matrix code (QR code) on the nameplate

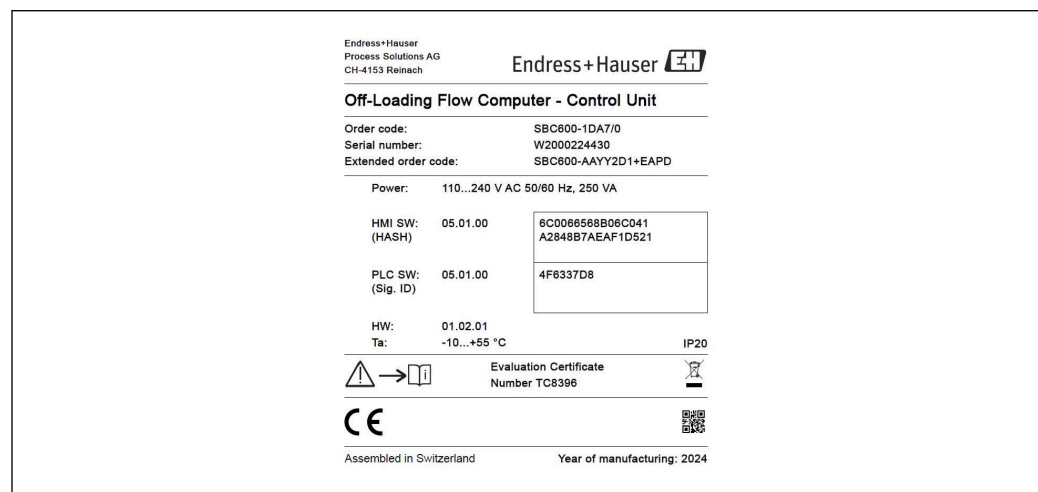

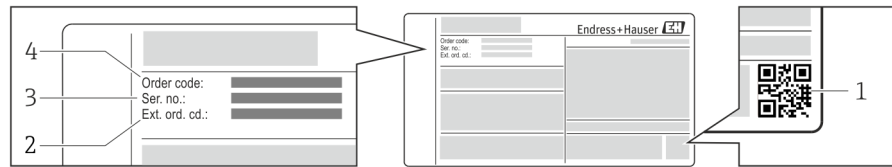

- 1 2-D matrix code (QR code)
- 2 Extended order code (Ext. ord. cd.)
- 3 Serial number (ser. no.)
- 4 Order code

An overview of the associated documentation is provided in the following:

- **Device Viewer:** Enter serial number from nameplate  
[www.endress.com/deviceviewer](http://www.endress.com/deviceviewer)
- The download area of the Endress+Hauser website  
[www.endress.com/downloads](http://www.endress.com/downloads)

### 4.3 Storage and transport

- The cabinet is packed in such a way that it is fully protected against shock when in storage and during transportation. The original packaging offers the best protection
- The permitted storage temperature is  $-20$  to  $+60$  °C ( $-4$  to  $140$  °F), preferably  $+20$  °C ( $68$  °F).
- When transporting the cabinet protect it from direct sunshine to avoid excessively high surface temperatures
- Store the cabinet packaged in a dry place
- Transport the cabinet to its final destination in the transportation box in which it was delivered

## 5 Installation

The SBC600 is supplied with brackets for wall mounting and must be mounted on a stable wall using suitable mounting equipment.

See below for an example of a system with an individual cabinet with installed mounting brackets and details of the mounting brackets.

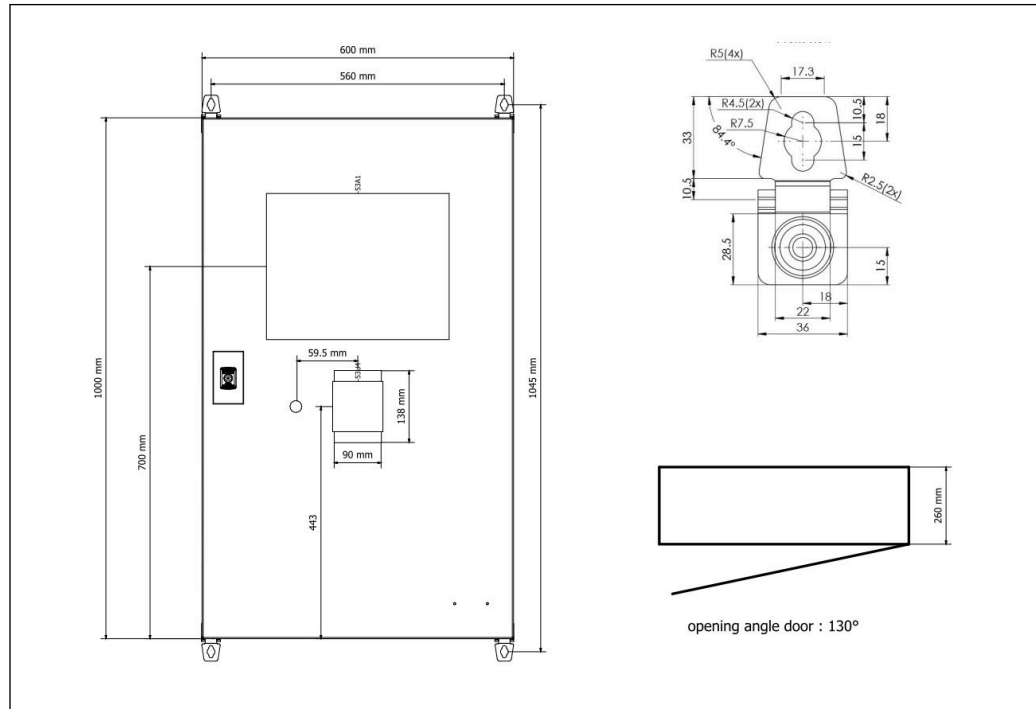

3 Single cabinet with the PLC and HMI in the same cabinet (control unit) for wall mounting.

**Two cabinets with the PLC (control unit) and HMI (operator terminal) in separate cabinets for wall mounting:**

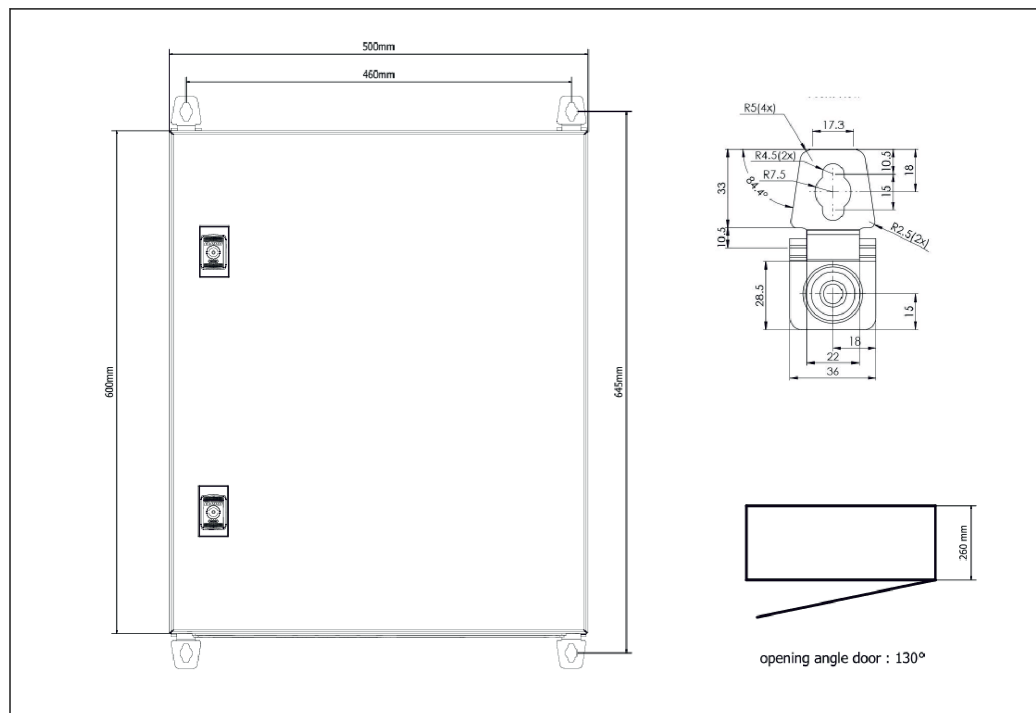

4 PLC (control unit) in a cabinet

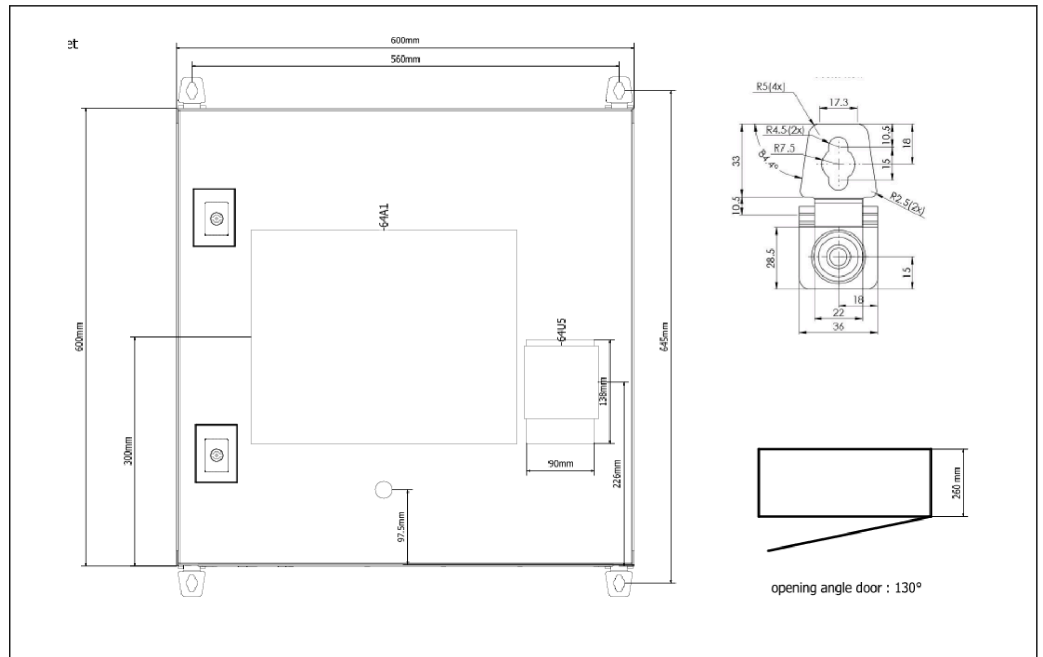

5 HMI (operator terminal) separately in one cabinet for wall mounting

Two cabinets with the PLC (control unit) in one cabinet for wall mounting and the HMI (operator terminal) in a desk panel:

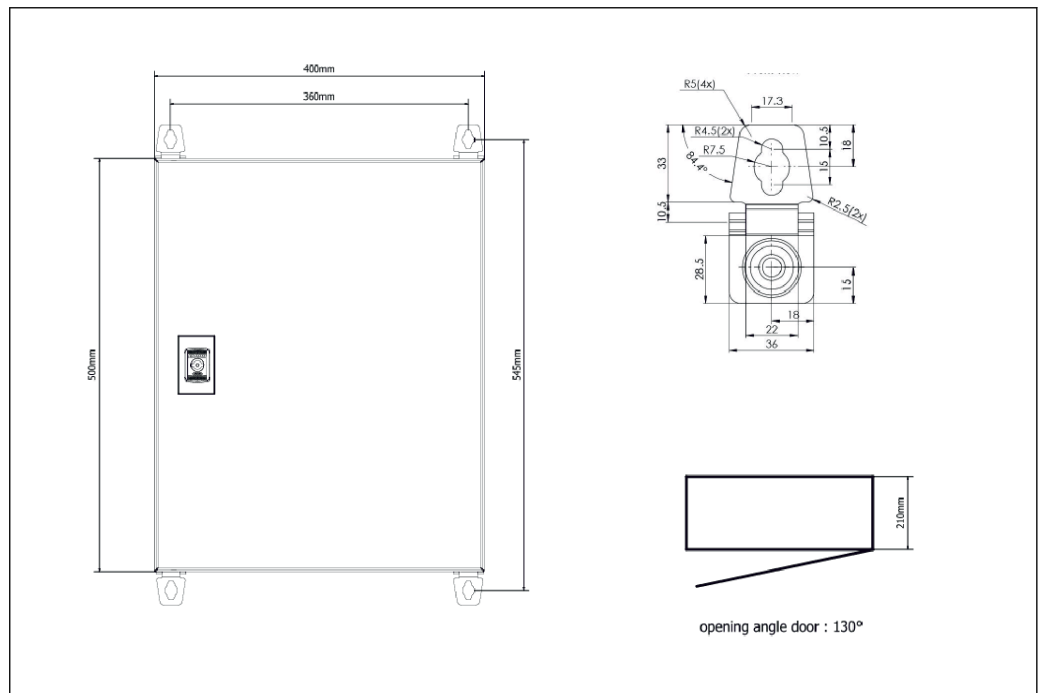

6 PLC (control unit) in a cabinet for wall mounting

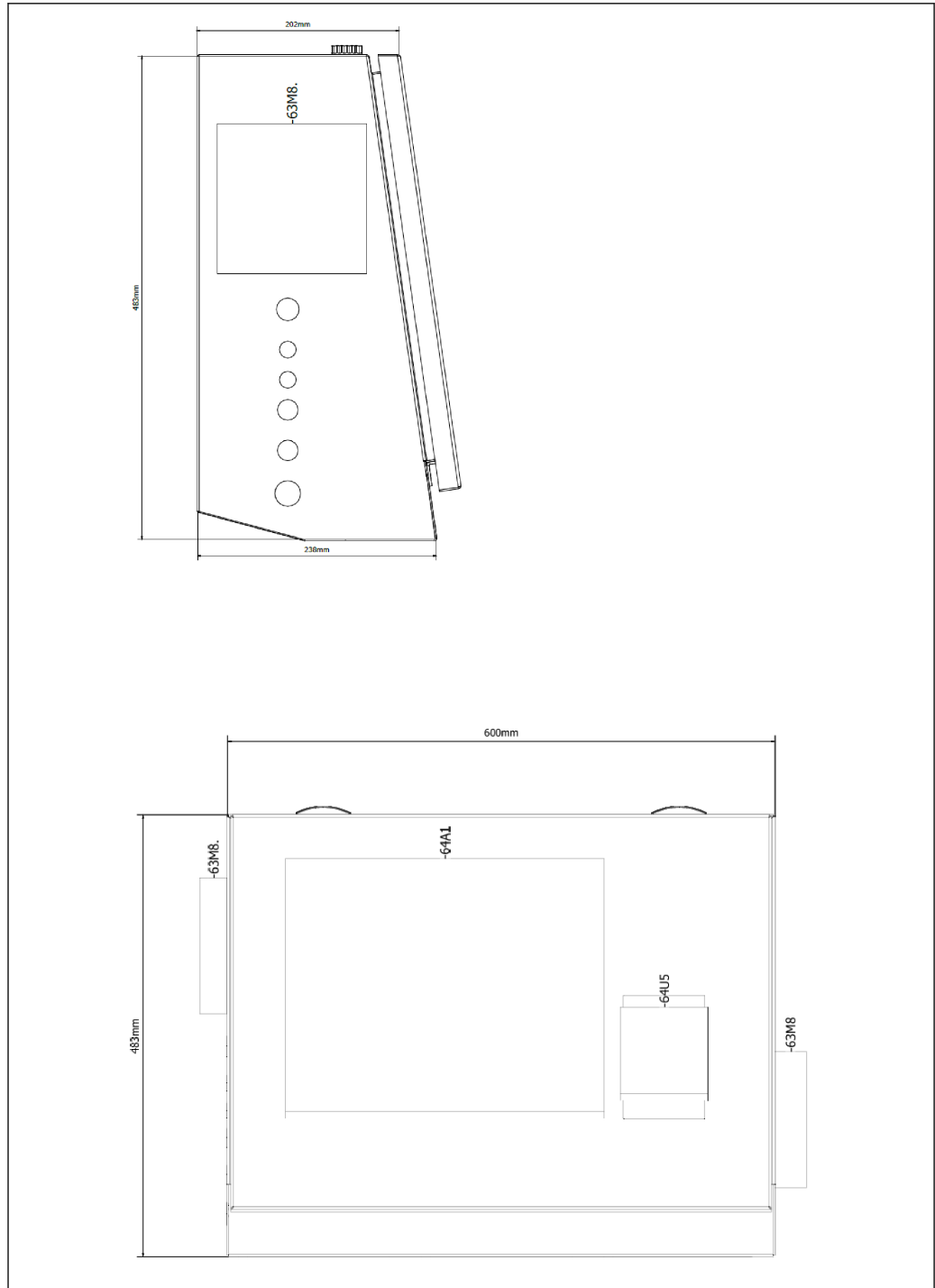

7 HMI (operator terminal) in a desk panel



## 6 Electrical connection

### 6.1 Connection conditions

#### 6.1.1 Required tools

- For cable entries: use suitable tools
- For securing clamp (stainless steel housing): 8 mm wrench
- Wire stripper
- When using standard cables: use a crimper for wire end ferrules
- Crimper for keystone jack and plug cat. 6A
- Universal measuring device for cable testing

#### 6.1.2 Connecting cable

##### **WARNING**

**As the cabinet is installed in a maritime environment,** the connecting cables and cable entries must meet special requirements.

- ▶ The requirements in these Operating Instructions must be met.

All network and signal cables used must be approved for use in the maritime industry in accordance with the latest technology and generally recognized rules of technology:

- All cables laid must be specifically designed for use in the maritime industry. In addition, they must meet requirements relating to ship class and have other necessary approvals.
- The use of armored cables is recommended, and these should be laid in fixed or flexible conduits to protect them from mechanical damage.
- All signal cables must be grounded. If multi-core cables are used, the individual signal cables must be grounded individually.
- All Ethernet connection cables must be Cable Type S/FTP Category 7 (individual pairs with braided shield and overall cable with foil shield).
- Required wire cross-sections:
  - Signal cable: 0.75 mm<sup>2</sup>
  - Power cable for AC: 1.5 mm<sup>2</sup>

#### 6.1.3 Ethernet connection

The RJ-45 Ethernet connections of the Ethernet cables must meet the following specifications: Keystone jack cat. 6A

#### 6.1.4 Cable entries and distribution box

The cable entries must meet all safety requirements applicable at the place of installation. These may include:

- Protection against climatic conditions
- Protection against corrosion
- Sealing off of any unused cable entries using dummy plugs.

 Additional use of a sealing compound to seal off connection seams or joints is common practice and has proven to be effective.

## 6.2 Special connection instructions

### Wiring the cabinet

The pressure sensors and the RTD assembly are powered directly via the Off-Loading Flow Computer (SBC600). The Coriolis mass flowmeter and the control valve are powered separately. Suitable circuit breakers must be provided for these devices.

**NOTICE**

**If the circuit breakers were installed in this cabinet, it would only be possible to access them by breaking the seal.**

- ▶ The circuit breakers may not be installed in the cabinets of the Off-Loading Flow Computer (SBC600) as these cabinets are sealed.

For the SBC600 and associated devices, the use of an uninterruptible power supply (UPS) is recommended. For the required power ratings, see **Section 14**. →  55

## 7 Operation options

### 7.1 Starting up and shutting down

#### 7.1.1 Starting up

The Off-Loading Flow Computer application starts automatically as soon as power is supplied to the system. It can take up to 5 minutes for the operating panel to start up. The **operator** user is automatically logged onto the Off-Loading Flow Computer after startup.

#### 7.1.2 Shutting down

The Off-Loading Flow Computer application can be shut down using the **Shutdown** button:



In the pop-up window that follows, select **CANCEL** to return to the previous screen, **RESTART** to restart the Off-Loading Flow Computer application, **SHUT DOWN** to shut down the PC or **LOG OFF** to log off the current **user** (for administration purposes only).

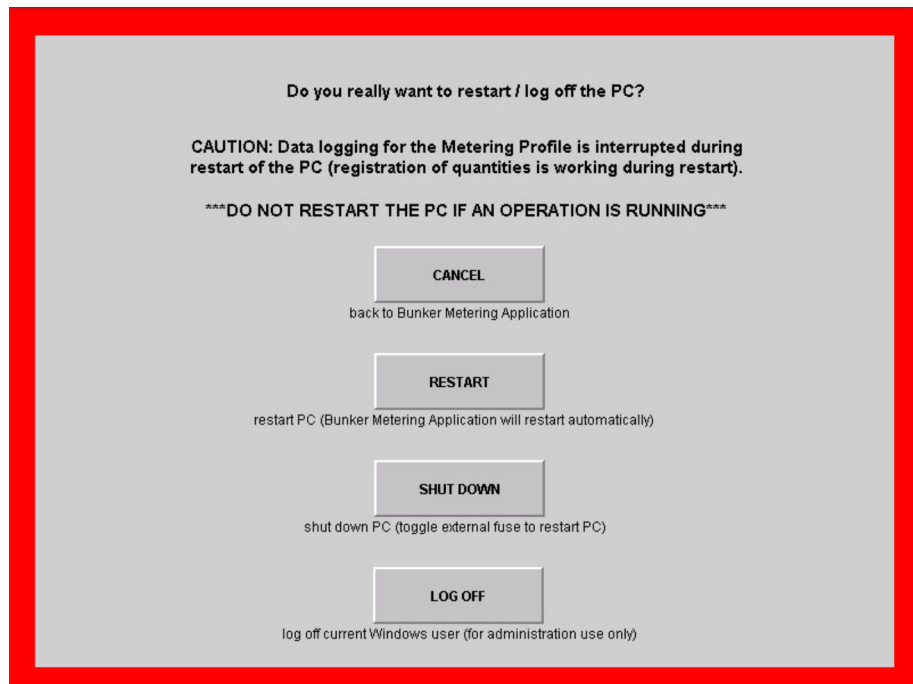

#### NOTICE

If the application is shut down during an off-loading operation/batch, this will result in inconsistent data in the metering profile.

- ▶ Do not restart during an off-loading operation/batch.



The Off-Loading Flow Computer stops all data logging if the application is shut down. If the PC is shut down, it can only be restarted by switching the main fuse.

## 7.2 Navigation

 Some of the following functionalities are only visible for the **supervisor**.

### 7.2.1 General screen layout

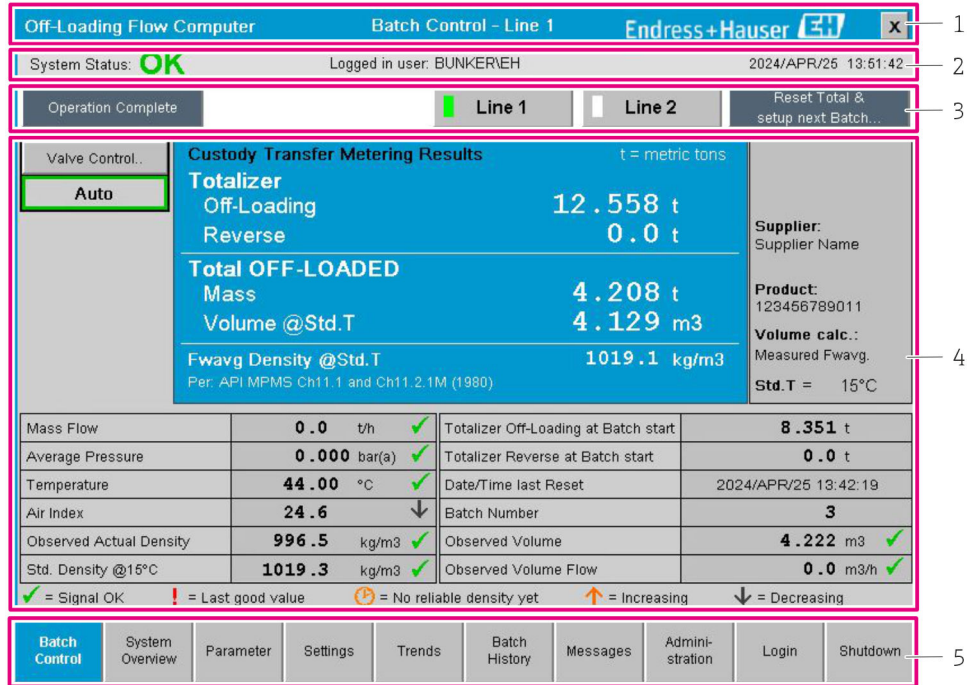

The screenshot shows the 'Batch Control - Line 1' screen. At the top, the header (1) displays 'Off-Loading Flow Computer', 'Batch Control - Line 1', and the 'Endress+Hauser' logo. Below this, the system status bar (2) shows 'System Status: OK', 'Logged in user: BUNKERIEH', and '2024/APR/26 13:51:42'. A function bar (3) includes 'Operation Complete', 'Line 1' (selected), 'Line 2', and 'Reset Total & setup next Batch...'. The main body (4) features a 'Custody Transfer Metering Results' section with 'Totalizer' data (Off-Loading: 12.558 t, Reverse: 0.0 t), 'Total OFF-LOADED' (Mass: 4.208 t, Volume @Std.T: 4.129 m3), and 'Fwavg Density @Std.T: 1019.1 kg/m3'. A table below shows various process parameters like Mass Flow, Average Pressure, and Temperature, along with their current values and status indicators. The bottom navigation bar (5) contains buttons for 'Batch Control', 'System Overview', 'Parameter', 'Settings', 'Trends', 'Batch History', 'Messages', 'Administration', 'Login', and 'Shutdown'.

 8 Main page

- 1 Header: Contains the system description (Off-Loading Flow Computer), the identification of the current screen and the Endress+Hauser logo. Clicking the logo opens the Diagnostic Information screen.
- 2 System Status bar: Displays the system status, the user currently logged in and the current date and time.
- 3 Function bar: Comprises function buttons or options for navigating within the display screen (depending on the user that is currently logged in).
- 4 Screen body: The content depends on the particular screen.
- 5 Navigation bar: For navigating between screens (depending on the user that is currently logged in). The screen that is currently selected is indicated by a blue button background.

## 7.3 Display screens and buttons

### 7.3.1 Batch Control screen

An off-loading operation is handled in the **Batch Control** screen:

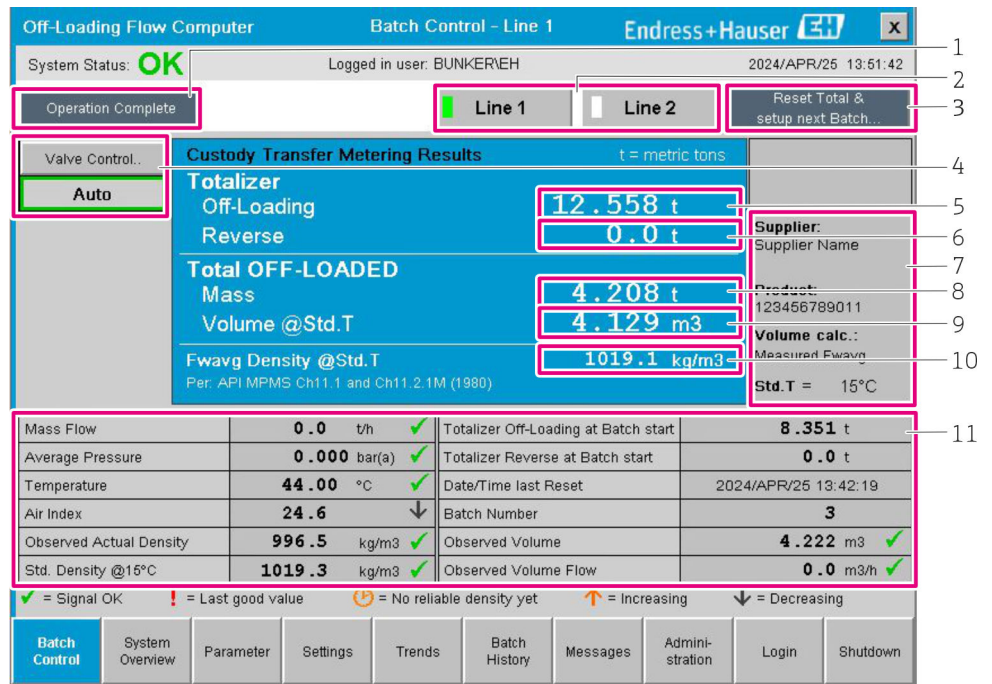

9 Batch Control screen

- 1 Operation Complete button, see Section 10.4 → 45
- 2 Line selection: Only visible on two-line systems
- 3 Reset Total button, preparation for an off-loading operation (reset totalizer to 0) or Reset Total & Product Select if volume measurement is enabled (reset totalizer to 0 and select product), see Section 10.2 → 41
- 4 Valve Control button with status indicator, see Section 7.5
- 5 Off-Loading totalizer, non-resettable
- 6 Reverse totalizer, non-resettable
- 7 Supplier currently selected, selected product, density and std. temperature, only visible if volume measurement is enabled
- 8 Resettable totalizer
- 9 Resettable totalizer in volume based on std. density at std. temperature, only visible if volume measurement is enabled
- 10 Current density at std. temperature, only visible if volume measurement is enabled
- 11 Parameter section: Overview of the parameters related to the off-loading operation

**NOTICE**

**If too much data is recorded under one batch,**

it might not be possible to create a metering profile (time-out error message).

- ▶ The **Reset Totalizer** function must be executed before the start of an off-loading operation even if the resettable totalizer already shows **0**. This ensures that the correct off-loading operation start time is recorded and that the metering profile does not contain unnecessary data.

### 7.3.2 System Overview screen

The **System Overview** screen provides an overview of the system:

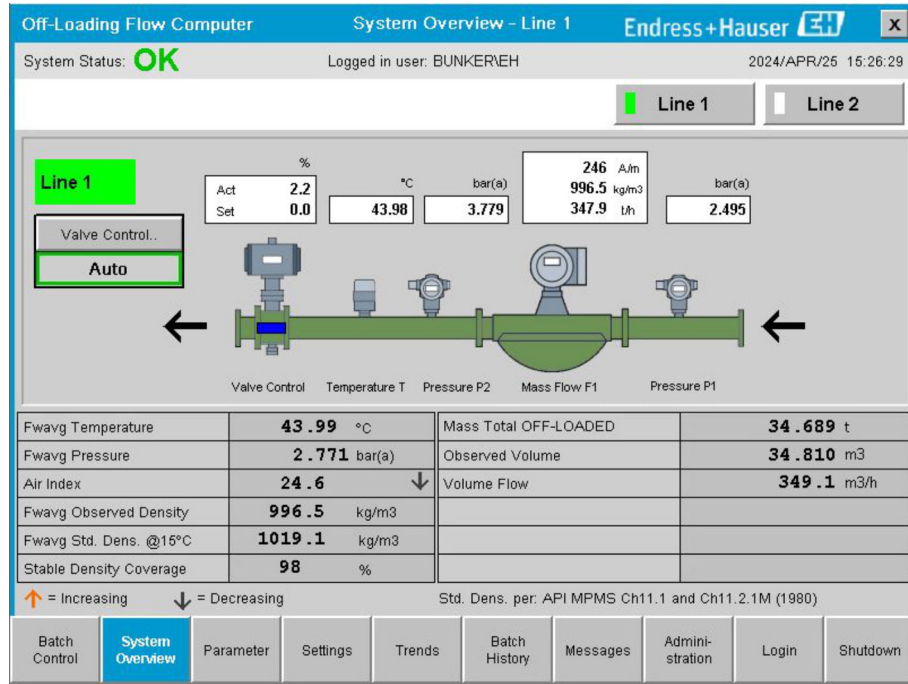

10 System Overview screen

- If a sensor is in a fault state, the corresponding value field flashes red
- Clicking the **Valve Control** value field opens the pop-up window for the control valve
- The color of the pipe changes to green as soon as flow is detected

### 7.3.3 Parameter screen

The **Parameter** screen (supervisor) contains additional data that are not displayed in the **Batch Control** or **System Overview** screens:



11 Parameters screen (supervisor)

- Different parameter tables can be displayed with the buttons in the **Function bar**
- The current state of the parameter value is displayed in the column on the far right

### 7.3.4 Settings screens

The **Settings – Alarming** (supervisor) screen is used to set the alarm settings for process values. The **Settings – Products** (supervisor) screen is only displayed if volume measurement is enabled. This screen is used to define and assign the products and the associated fluid groups.

#### Settings – Alarming screen

The **Settings – Alarming** (supervisor) screen is used to set the alarm settings for process values. Alarms can be enabled and disabled. All alarms are disabled by default. The enabled alarms are displayed. See also **Section 11.2** → 48. The two customer-specific relay outputs can be configured with the process value required for alarm output. See also **Section 9.4** → 37.

The screen is displayed in the graphic below:

Alarming		Line1: HFO				Line2: MGO				
Alarm-Triggers	Unit	Range	Limit	Alarm Enable	Relay 1	Relay 2	Limit	Alarm Enable	Relay 1	Relay 2
None (Disable Relay)				<input type="checkbox"/>	<input checked="" type="radio"/>	<input checked="" type="radio"/>		<input type="checkbox"/>	<input checked="" type="radio"/>	<input checked="" type="radio"/>
Flowrate mass F	t/h	Low High	0 1500	<input type="checkbox"/>	<input checked="" type="radio"/>	<input type="radio"/>	0 1500	<input type="checkbox"/>	<input checked="" type="radio"/>	<input type="radio"/>
Temperature T	°C	Low High	0 80	<input type="checkbox"/>	<input type="radio"/>	<input type="radio"/>	0 80	<input type="checkbox"/>	<input type="radio"/>	<input type="radio"/>
Pressure P1	bar(a)	Low High	0.0 10.0	<input type="checkbox"/>	<input type="radio"/>	<input type="radio"/>	0.0 10.0	<input type="checkbox"/>	<input type="radio"/>	<input type="radio"/>
Pressure P2	bar(a)	Low High	0.0 10.0	<input type="checkbox"/>	<input type="radio"/>	<input type="radio"/>	0.0 10.0	<input type="checkbox"/>	<input type="radio"/>	<input type="radio"/>
Std. Density @15°C	kg/m3	Low High	0.0 1100.0	<input type="checkbox"/>	<input type="radio"/>	<input type="radio"/>	0.0 1100.0	<input type="checkbox"/>	<input type="radio"/>	<input type="radio"/>
Observed Density	kg/m3	Low High	0.0 1100.0	<input type="checkbox"/>	<input type="radio"/>	<input type="radio"/>	0.0 1100.0	<input type="checkbox"/>	<input type="radio"/>	<input type="radio"/>
Air Index Warning	-	High	1500	<input type="checkbox"/>	<input type="radio"/>	<input type="radio"/>	1500	<input type="checkbox"/>	<input type="radio"/>	<input type="radio"/>

12 Settings – Alarming (supervisor) screen

#### Settings – Products screen

The **Settings – Products** (supervisor) screen is only displayed if volume measurement is enabled. On this screen, the products are assigned to a fluid group and can be given a customized name. The visibility of the products and a default product can be selected per line. The values for the selected fluid group are displayed in the lower part of the screen.

The screen is displayed in the graphic below:

**Bunker Metering Computer Settings** Endress+Hauser

System Status: **OK** Logged in user: supervisor 2018/FEB/23 14:40:58

Alarming | **Products**

Products Name	Fluid Type	Lab Std. Density kg/m3	HFO Show	HFO Default	MGO Show	MGO Default
CustProd1	Crude	840.0	<input checked="" type="checkbox"/>	<input type="radio"/>	<input checked="" type="checkbox"/>	<input checked="" type="radio"/>
CustProd2	Gasoline	701.0	<input checked="" type="checkbox"/>	<input checked="" type="radio"/>	<input type="checkbox"/>	<input type="radio"/>
CustProd3	Trans. area	775.0	<input checked="" type="checkbox"/>	<input type="radio"/>	<input type="checkbox"/>	<input type="radio"/>
CustProd4	Jet group	800.0	<input checked="" type="checkbox"/>	<input type="radio"/>	<input type="checkbox"/>	<input type="radio"/>
CustProd5	Fuel oil	950.0	<input checked="" type="checkbox"/>	<input type="radio"/>	<input type="checkbox"/>	<input type="radio"/>
CustProd6	Gasoline	700.0	<input checked="" type="checkbox"/>	<input type="radio"/>	<input type="checkbox"/>	<input type="radio"/>
CustProd7	Trans. area	775.0	<input checked="" type="checkbox"/>	<input type="radio"/>	<input type="checkbox"/>	<input type="radio"/>
CustProd8	Jet group	800.0	<input checked="" type="checkbox"/>	<input type="radio"/>	<input type="checkbox"/>	<input type="radio"/>

**Fluid Type** Gasoline (Source: API MPMS Ch11.1 and Ch11.2.1M (1980))

- Density Min. and Max. for valid Range: 653.0 770.0 kg/m3

- Default Std. Density @15°C: 700.0 kg/m3

- Coef. K0,K1,K2 for API Density calc.: 346.443000 0.438800 0.000000

Batch Control | System Overview | Parameter | **Settings** | Trends | Batch History | Messages | Administration | Login | Shutdown

13 Settings - Products (supervisor) screen

### 7.3.5 Trends screen

The **Trends** screen displays values in graphical form:

**Bunker Metering Computer Trends - HFO** Endress+Hauser

System Status: **OK** Logged in user: supervisor 2016/05/12 09:55:39

HFO | MGO

Historical Trends Line 1 Thursday, May 12, 2016

8:55:39 AM 9:07:39 9:19:39 9:31:39 9:43:39 9:55:39 AM

Caption	9:55:39 AM	Min	Max	Units
Temperature T1	23.64	0.00	100.00	°C
Pressure P1	1.30	0.00	10.00	Bar(a)
Pressure P2	6.24	0.00	10.00	Bar(a)
Mass Rate	-353.76	-1,000.00	1,000.00	th
Air Index	24.57	0.00	10,000.00	-
Std. Density (@15°C)	1,002.21	0.00	1,100.00	kg/m3

Batch Control | System Overview | Parameter | Settings | **Trends** | Batch History | Messages | Administration | Login | Shutdown

14 Trends screen

- If a separate **external data logger** is used, only the real-time trends are displayed on the **Trends** screen. This means that the **Trends** screen is empty when it is invoked and data logging only starts when the **Trends** screen is active.
- The following values are displayed: Temperature T1, Pressure P1, Pressure P2, Mass Rate, Air Index and Standard Density (@ 15 °C/15 °C).



The data of the last hour are shown by default. This time frame can be adjusted using the buttons:

	Show oldest data
	Go back 60 minutes
	Go back 30 minutes
	Pause/resume data refresh (if data refresh is not interrupted, the data are updated every 2 seconds)
	Go forward 30 minutes
	Go forward 60 minutes
	Show latest data

### 7.3.6 Batch History screen

The **Batch History** screen shows the data of the last 50 off-loading operations (including in-transit operations which do not show a totalized quantity of 0.0 T):

Batch Number	Date/Time @ Batch Start	Date/Time @ Batch End	Operation Mode	Total DELIVERED
000000001	2016/MAY/12 09:40:45	2016/MAY/12 09:56:48	Loading	70.691 t
000000000	2016/MAY/12 09:13:01	2016/MAY/12 09:40:45	Delivery	1.627 t
000000000				t
000000000				t
000000000				t
000000000				t
000000000				t
000000000				t
000000000				t
000000000				t

15 Batch History screen

- Clicking a data row opens the corresponding **Batch History Details** window
- Navigate up and down with the arrow buttons to the right side of the batch history table
- **Metering profiles** for the batches can be opened using the button in the function bar, see **Section 7.6**.

### 7.3.7 Batch History Details screen

The **Batch History Details** screen shows the detailed data of the selected off-loading operation:

16 Batch History Details screen

### 7.3.8 Messages screen

The **Messages** screen shows all the messages that are currently active:

17 Messages screen

More detailed information on the messages is provided in **Section 11.2.** → 48

### 7.3.9 Administration screen

The functions of the **Administration** screen are described in **Section 9.** → 36

### 7.3.10 Diagnostic Information screen

The **Diagnostic Information** screen contains diagnostics-related information. This information is helpful when troubleshooting and should be sent to Endress+Hauser for all kinds of service requests. For more information on the **Diagnostic Information** screen, see **Section 9** → 36

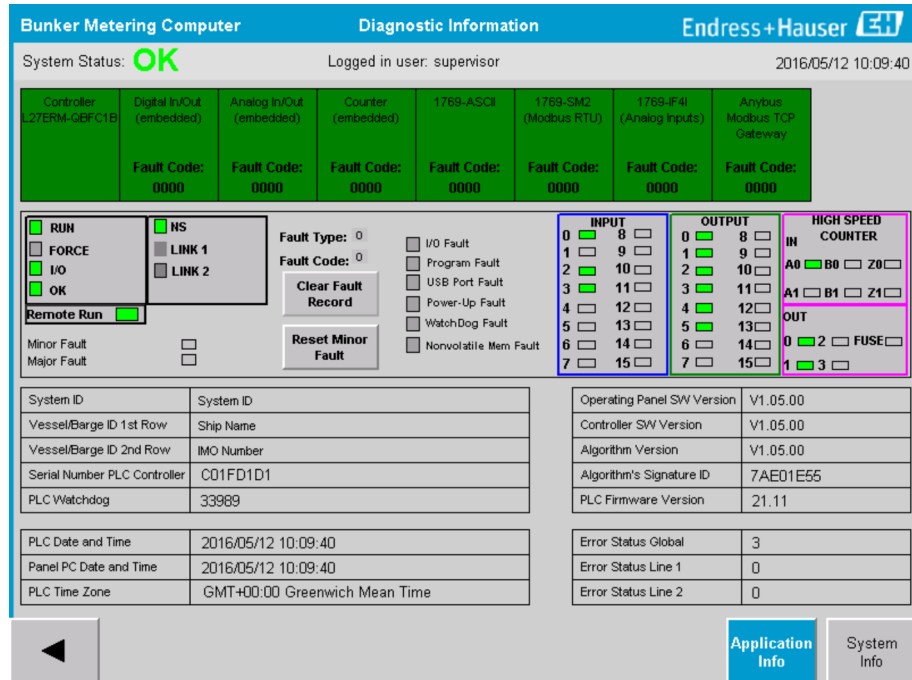

18 Diagnostic Information screen

### 7.3.11 Messages Historical screen

The **Messages Historical** screen (supervisor) can be opened from the **Administration** screen by clicking the **Messages Historical** button. For more information on the **Messages Historical** screen, see **Section 9** → 36

All the messages that are no longer active (past messages) are displayed here:

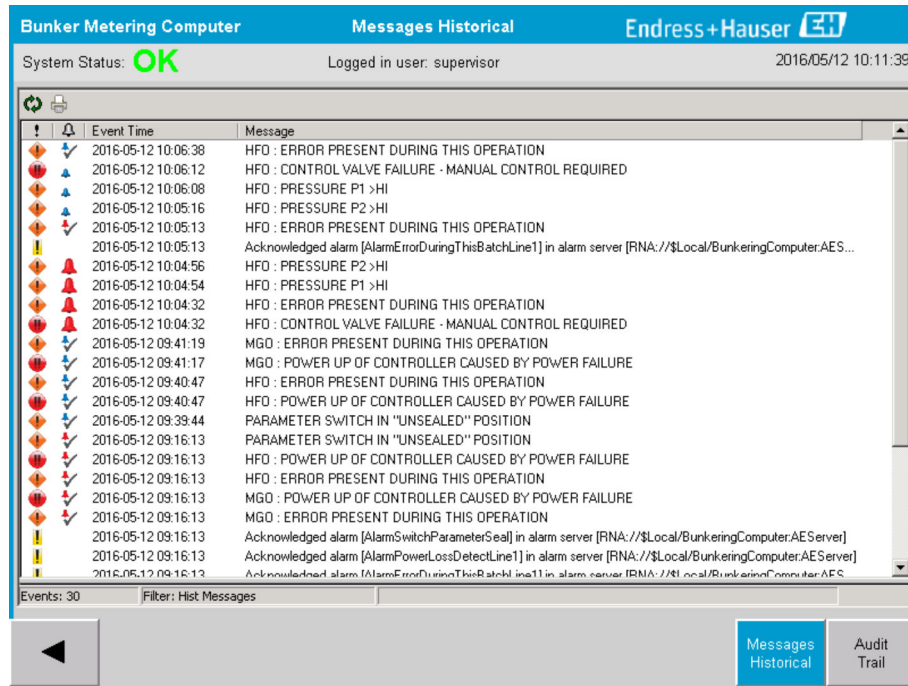

19 Messages Historical screen (supervisor)

### 7.3.12 ZERO Verification screen

**Zero Verification** (supervisor) is an important part of the subsequent verification which a metering installation undergoes and is used to verify that the zero value stored in the flowmeter meets the requirements during periodical inspections/recalibrations. The Zero Verification process is described in a separate document for the given installation and must be followed closely.

The Off-Loading Flow Computer functionality described below supports this process. The deviation between the stored zero value and the observed zero point shift is calculated and must be within an acceptable range. The **ZERO Verification** function can be accessed via the **Administration** page. For more information on the **ZERO Verification** screen, see **Section 9** → 36

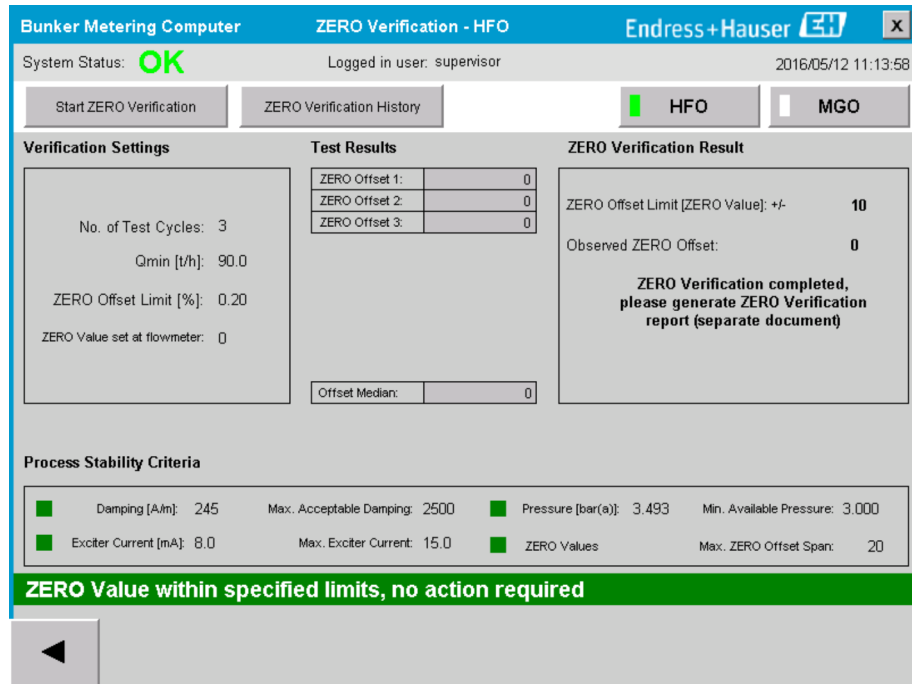

20 ZERO Verification screen (supervisor)

- ▶ **Process Stability Criteria:** A zero verification process can only be started if process conditions are within the limits (marked green). These limits are set during commissioning and can only be modified by Endress+Hauser. Click the **Start ZERO Verification** button.
  - ↳ The verification process starts with the values specified under **Verification Settings**.  
 Measurement: Intermediate result of the zero point shift for every measuring cycle. Once the specified number of cycles has been performed, the median value is determined.  
 If the zero verification process is concluded successfully, the result is displayed under **ZERO Verification Result**. The following results are possible:

Status	Color	Text on the HMI	Limit values
Good	Green	ZERO Value within specified limits, no action required	The zero point deviation is within the range of ± the maximum value
Adjustment	Yellow	ZERO Value shall be adjusted. Please contact the supervisor for further steps	The zero point deviation is within the range of ± the maximum value and 2 * ± the max. value
Inspection	Red	ZERO Value needs inspection. Please contact Endress+Hauser service for further steps	The zero deviation is greater than 2 * ± the maximum value

The last 10 zero verification processes can be viewed:

- ▶ Click the **ZERO Verification History** button.
  - ↳ The **Zero Verification History** screen opens.

### 7.3.13 Audit Trail screen

The **Audit Trail** screen (supervisor) shows all the process-related changes made in the system. For more information on the **Audit Trail** screen, see **Section 9** → 36

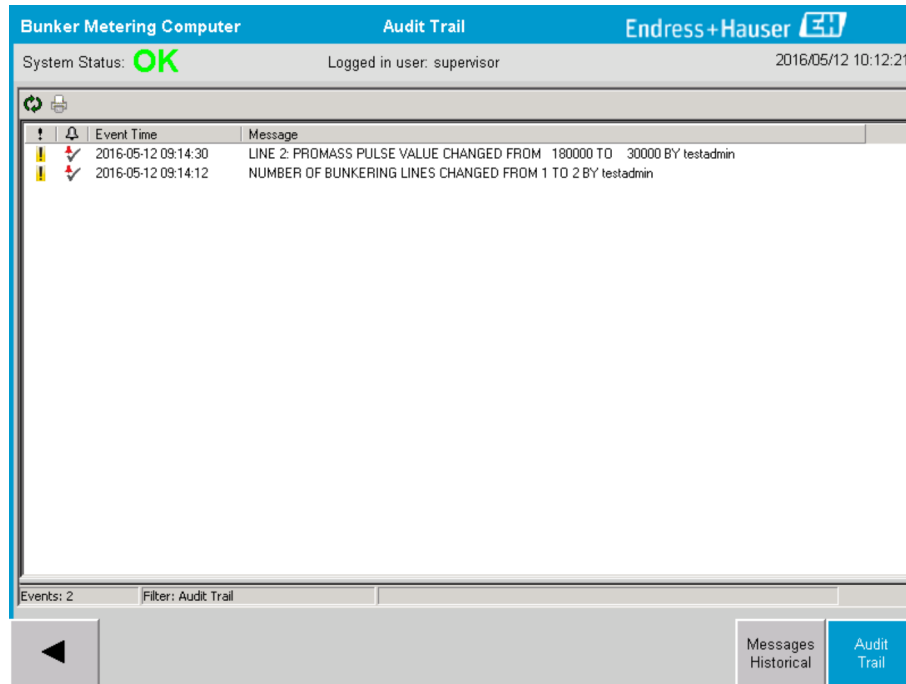

21 Audit Trail screen (supervisor)

To switch to the **Audit Trail** screen:

- ▶ Click the **Audit Trail** button in the **Administration** screen.

**i** Each time a parameter value is changed (and it is part of the audit trail), the old and the new value are displayed along with a date/time stamp and the name of the user who performed the parameter change.

### 7.3.14 Show Keyboard button

Pressing the **Show Keyboard** button (supervisor) will cause a virtual keyboard to be displayed. This keyboard can be used if the touch screen functionality is not sufficient.

### 7.3.15 Display Off button

The **Display Off** button (supervisor) only switches off the screen (system/measurements continue running in the background). For more information on the **Display Off** button, see **Section 9** → 36

## 7.4 Valve control

A control valve is installed in many applications to ensure that the pipe is filled quickly and remains filled during the off-loading operation. This is achieved by maintaining a certain pressure at the outlet side of the measuring device. There are three possible operation modes for the control valve:

- **Automatic Control:** The Off-Loading Flow Computer controls the valve automatically using the set point
- **Manual Control:** The control valve can be operated manually by selecting the required open/closed position from 0–100% in the **Valve Control** window on the Off-Loading Flow Computer. This window opens when you touch **Valve Control**
- **Manual operation:** The control valve is normally equipped with a hand-wheel for emergency manual override or manual operation in the event of a malfunction. Please refer to the control valve manual for more detailed information.

During **Loading** and **Delivery** operations, the control valve is normally in **Automatic Control** mode. During **loading operations**, the control valve actively controls the pressure while it remains completely open during **delivery operations**. The control valve can be switched to Manual Control at any time.

### **⚠ DANGER**

**Incorrect valve operation can result in high pressure ratings,** which can cause serious damage and/or serious injury during loading and delivery.

- ▶ Only operate the control valve in **Manual Control** mode if this is absolutely essential; proceed with extreme care here.

If a valve error or valve failure occurs, the control valve automatically switches to **Manual Control** mode. Manual operation might be necessary depending on the cause of the problem. The **Valve Control** button and the **Valve Control** window are orange in Manual Control mode, and blue in **Automatic Control** mode.

The screenshot displays the Bunker Metering Computer HMI interface. The main window shows system status as 'OK' and 'Operation Complete'. A 'Valve Control' window is open, showing 'Back Pressure Control Valve - MGO' in 'Automatic' mode. The window includes a PID Controller Settings section with a graph of ACT (Actual) and SET (Setpoint) values, and a table of parameters.

Parameter	Value	Unit
P	2	
I	65	
D	10	
Actual value (ACT)	0.000	bar(a)
Setpoint (SET)	1.300	bar(a)
Man. Controller Output		%
Controller Output (CV)	0	%
Controller Start Value	045	%
Mass Rate Thres. for Auto Mode	0000.1	t/h
Delay Time for Auto Mode	001	s

Current Operating Mode: **AUTOMATIC**

## 7.5 Metering profiles

The Off-Loading Flow Computer has the functionality to create a metering profile for each off-loading operation performed.

Two different configurations are possible:

- **Standard option:** Use the database of the Off-Loading Flow Computer and create the metering profiles directly from the operating panel.
- **Alternative:** Use an external data logger. The data is then stored on this separate external unit and can be downloaded from there.

One of the two options is set up by Endress+Hauser during system commissioning.

### 7.5.1 Metering profiles from the HMI operating panel

If the **Metering Profile** function is enabled on the operating panel (only if no external data logger is used), both **operator** and **supervisor** users can create metering profiles for the off-loading operations performed. The function can be accessed via the **function bar** in the **Batch History** screen:



The **operator** user can access the **Standard Metering Profile** function. The **supervisor** user can also use the **Extended Metering Profile** function. The **Standard Metering Profile** contains information on **Mass Flow, Air Index, Damping** and **Standard Density**. The **Extended Metering Profile Expert** contains additional information on temperature and pressures during off-loading.

Both buttons open the **Off-Loading Metering Profile** window that contains a list of all the off-loading operations recorded. By default, only the last 25 metering profiles are displayed. If necessary, older metering profiles can be loaded from the drop-down list at the bottom of the application for metering profiles:

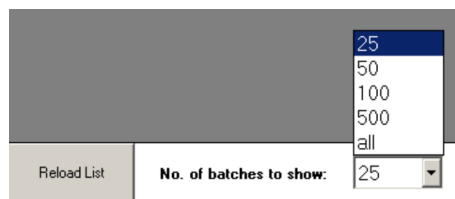

**Bunker Metering Profile**

Line 1	Bunker Ticket No.	Operation Mode	Batch Mode	Mass Total	Start Time	End Time
3		Delivery	Mass in Air	16.607	2015/08/13 12:20	2015/08/13 12:23
2		Delivery	Mass in Air	143.183	2015/08/13 12:01	2015/08/13 12:20
1		Delivery	Mass in Air	20.380	2015/08/13 11:58	2015/08/13 12:01
0		Unknown	Unknown	Unknown		2015/08/10 13:46

Version 1.2.0.1

Reload List    No. of batches to show: 25    Generate Report    Exit

1. Select a batch from the list.
2. Click the **Generate Report** button.
  - ↳ The metering profile report is generated.
3. Click the **Exit** button.

The generated metering profile report appears in a separate window.



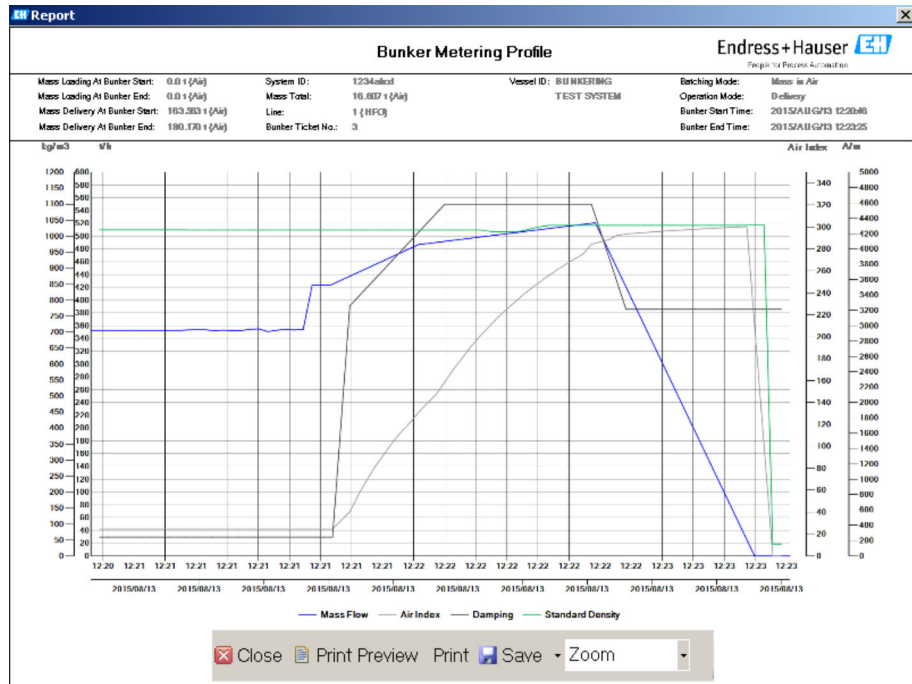

- i
  - Click the **Save** button to save the metering profile report as a PDF or Excel file on a connected data storage drive. Once the required file format has been selected, the user can enter a file name for the file to be saved.
  - If a more in-depth analysis of the off-loading operation data is required, the data can be exported to a CSV file using the CSV function. This file can then be exported and sent to an Endress+Hauser specialist.

## 7.6 Special functions

### 7.6.1 Air Index warning

The Air Index (AI) is a parameter which is normally used for ascertaining whether a batch is within the specified accuracy limits. In addition, it can also give the operator(s) information at any time as to whether the off-loading operation is within the acceptable limits. The aim of the Air Index warning function is to improve the overall conditions during an off-loading operation.

The off-loading operation normally starts with an empty piping system and a correspondingly high Air Index. This period is bridged with a delay time before a warning that the Air Index is too high is issued. The warning is disabled as soon as the Air Index value drops below the limit value for a reduced standard delay time and is enabled again as soon as it exceeds this limit for the same period.

The value and status are shown in the **Batch Control** screen:

Mass Flow:	694.5	T/h (Air)	good	Totalizer Loading at Batch Start	0.0	T (Air)
Pressure P2:	0.000	Bar(a)	good	Totalizer Delivery at Batch Start	415.254	T (Air)
Temperature:	22.5	°C	good	Date/Time last Reset	2014/APR/29 17:17:46	
Fwavg Temperature:	22.5	°C				
Flowing Density:	953.6	kg/m3	good			
Air Index:	1823.9		decreasing	Batch Number	000000003	

The Air Index warning is listed in the **Messages** screen:



## 8 System integration

The Off-Loading Flow Computer is always in measuring mode and therefore continuously totalizes the quantity of fuel flowing through the measurement section.

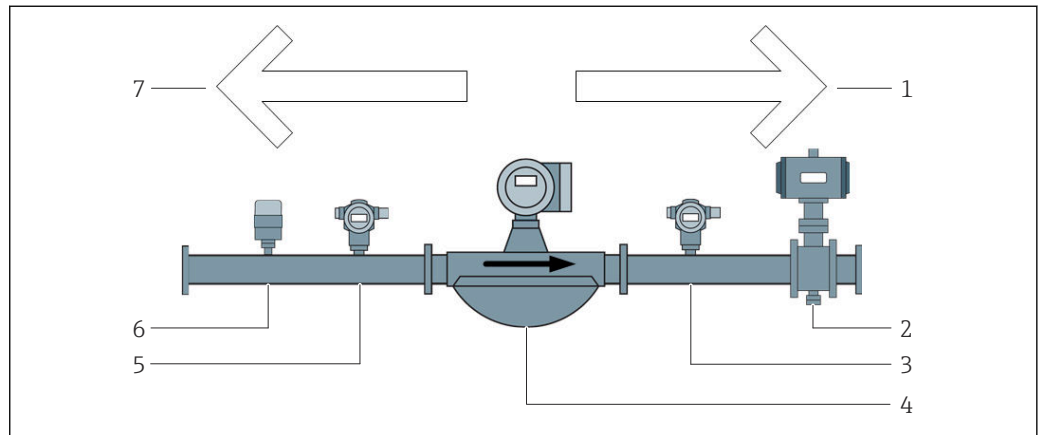

22 Installation

- 1 Off-Loading = positive flow rate
- 2 Control valve
- 3 Pressure P2
- 4 Coriolis flowmeter
- 5 Pressure P1
- 6 Temperature T1
- 7 Reverse = negative flow rate

## 9 Commissioning

### 9.1 Change date and time

The system time can be changed via the function to **edit the date and time** by clicking the **Change Date and Time** button.

#### NOTICE

If the date and time settings are changed while an off-loading operation is running, this can cause inconsistencies in the batch data and in the database.

- ▶ Do not change the date and time settings while an off-loading operation is running.

#### NOTICE

If the date, time or time zone settings are changed the database might no longer be synchronized.

- ▶ Restart the Off-Loading Flow Computer panel after changing the date and time or time zone settings in order to synchronize the database with the correct date and time settings.

#### NOTICE

If the application is shut down during an off-loading operation or batch, this can result in inconsistent data in the metering profile.

- ▶ Do not restart during an off-loading operation or batch.

Part	Identifier	Version/Checksum
Operating Panel	Version	5.00.00
Controller (PLC)	Version	5.00.00
HMI Program (L)	Checksum	DC244D023BC6F46C3B451D45A9587434
Sealed Algorithm (L)	Version	5.00.00
Sealed Algorithm (L)	Signature ID.	0

Settings	Destination	Checksum
Supplier Names	USB drive	-
Sealed only	USB drive	3E57DB19BD265066C0C3E5029CAF4815
All	USB drive	-

23 Administration screen (supervisor)

Only the date and time can be changed on the **Administration** screen. If the time zone settings need to be changed, this must be done using the Windows functions for setting the date and time. The default setting for the time zone is UTC. The time zone is set to the local time zone during commissioning.

## 9.2 Exporting the settings

The current system settings can be exported onto a USB stick. It is possible to export either all the settings or only the settings that are relevant for custody transfer (sealed).

### Exporting the settings

1. Select the **Administration** view.
  - ↳ The **Administration** view is displayed.

Part	Identifier	Version/Checksum
Operating Panel	Version	5.00.00
Controller (PLC)	Version	5.00.00
HMI Program (L)	Checksum	DC244D023BC6F46C3B451D45A9587434
Sealed Algorithm (L)	Version	5.00.00
Sealed Algorithm (L)	Signature ID	0

Settings	Destination	Checksum
Supplier Names	USB drive	-
Sealed only	USB drive	3E57DB19BD265066C0C3E5029CAF4815
All	USB drive	-

2. Connect the USB stick to the system.
3. Wait until the system recognizes the USB stick. This takes approx. 1 minute.
4. Click the corresponding **Export** button to export the desired **Settings**.
  - ↳ A window appears.
5. Click the **OK** button.
  - ↳ The settings are exported to the USB stick.

## 9.3 BMC Service Tool

 For details on the **BMC Service Tool** screen (**supervisor**), see the separate **BMC Service Tool** document.

## 9.4 User administration

A user administration system is available which is used to set up access authorization for the Off-Loading Flow Computer. Specific functions described in this user manual for setting up access authorization are available only to higher-level users (**supervisor**).

### 9.4.1 User levels

The following user levels are available:

User name	Password
operator	operator (default)
supervisor	supervisor

The **operator** user is logged in automatically when the system starts up. When the **supervisor** user logs out, the **operator** user is automatically logged in.

The password for the **supervisor** user can be changed by clicking the **Change Password** button.

#### NOTICE

If the password for the supervisor has been forgotten, it cannot be reset by the user.

- ▶ Only Endress+Hauser service staff can reset a password (this can be done onsite only, a manual reset of the password is not possible).

### 9.4.2 Log in/log out

Users can only log in via the **Login** screen. The current user can only be logged out and the password changed in the **Administration** screen.

The screenshot shows the Administration screen with the following data:

Part	Identifier	Version/Checksum
Operating Panel	Version	5.00.00
Controller (PLC)	Version	5.00.00
HMI Program (L)	Checksum	DC244D023BC6F46C3B451D45A9587434
Sealed Algorithm (L)	Version	5.00.00
Sealed Algorithm (L)	Signature ID	0

Settings	Destination	Checksum
Supplier Names	USB drive	-
Sealed only	USB drive	3E57DB19BD265066C0C3E5029CAF4815
All	USB drive	-

24 Administration screen (supervisor)

### 9.4.3 Access authorization

User-specific access authorizations are listed in the following table:

Display screens	operator	supervisor
Batch Control	<input checked="" type="checkbox"/>	<input checked="" type="checkbox"/>
System Overview	<input checked="" type="checkbox"/>	<input checked="" type="checkbox"/>
Parameter	<input checked="" type="checkbox"/>	<input checked="" type="checkbox"/>

Display screens	operator	supervisor
Settings	<input checked="" type="checkbox"/>	<input checked="" type="checkbox"/>
<b>Trends</b> screen	<input checked="" type="checkbox"/>	<input checked="" type="checkbox"/>
Batch History	<input checked="" type="checkbox"/>	<input checked="" type="checkbox"/>
Messages	<input checked="" type="checkbox"/>	<input checked="" type="checkbox"/>
Administration	<input checked="" type="checkbox"/>	<input checked="" type="checkbox"/>
Messages Historical	<input checked="" type="checkbox"/>	<input checked="" type="checkbox"/>
Audit Trail	<input checked="" type="checkbox"/>	<input checked="" type="checkbox"/>
ZERO Verification	<input checked="" type="checkbox"/>	<input checked="" type="checkbox"/>
Custom Relay Output Config.	<input checked="" type="checkbox"/>	<input checked="" type="checkbox"/>
Diagnostic Information	<input checked="" type="checkbox"/>	<input checked="" type="checkbox"/>

Operation	operator	supervisor
Run the <b>Operation Complete</b> function	<input checked="" type="checkbox"/>	<input checked="" type="checkbox"/>
Run the <b>Reset Total</b> function	<input checked="" type="checkbox"/>	<input checked="" type="checkbox"/>
Manual valve control	<input checked="" type="checkbox"/>	<input checked="" type="checkbox"/>
Show and print out metering profiles	<input checked="" type="checkbox"/>	<input checked="" type="checkbox"/>
Show and print out <b>Extended Metering Profiles</b>	<input checked="" type="checkbox"/>	<input checked="" type="checkbox"/>
Display and acknowledge messages	<input checked="" type="checkbox"/>	<input checked="" type="checkbox"/>

Administration	operator	supervisor
Change the password for the <b>supervisor</b> user	<input checked="" type="checkbox"/>	<input checked="" type="checkbox"/>
End the application	<input checked="" type="checkbox"/>	<input checked="" type="checkbox"/>
Change settings for date and time	<input checked="" type="checkbox"/>	<input checked="" type="checkbox"/>
Show Windows keyboard	<input checked="" type="checkbox"/>	<input checked="" type="checkbox"/>

Settings	operator	supervisor
Change settings for control valve	<input checked="" type="checkbox"/>	<input checked="" type="checkbox"/>
Change PID settings for control valve	<input checked="" type="checkbox"/>	<input checked="" type="checkbox"/>
Change alarm limits	<input checked="" type="checkbox"/>	<input checked="" type="checkbox"/>

## 9.5 Relay outputs

Floating relay output contacts are available that allow easy access to overall system status information and other warnings. More information on the wiring scheme can be found in the wiring diagram.

### 9.5.1 System status

Two floating contacts are available for outputting the system status (for more information on the system status, see **Section 11.1** →  48):

Function	Relay contact open	Relay contact closed
System status WARNING	System status WARNING - active	System status WARNING - not active
System status is ERROR	System status ERROR - active	System status ERROR - not active

If both floating contacts are closed, then the system status is **OK** (fail safe operation).

### 9.5.2 Custom warnings

Two floating contacts are available for user-configurable warnings. These warnings are configured via the **Settings** screen.

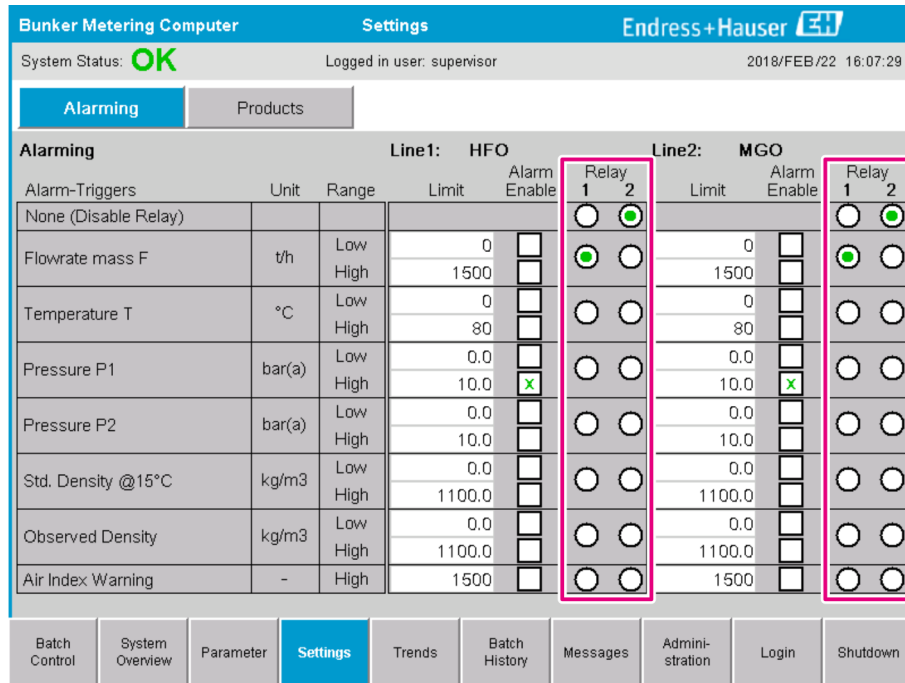



The following warnings are available:

Function	Relay contact open	Relay contact closed
Flowrate mass F	At least one message relating to <b>Flowrate mass F</b> is active	No message relating to <b>Flowrate mass F</b> is active
Temperature T	At least one message relating to <b>Temperature T</b> is active	No message relating to <b>Temperature T</b> is active
Pressure P1	At least one message relating to <b>Pressure P1</b> is active	No message relating to <b>Pressure P1</b> is active
Pressure P2	At least one message relating to <b>Pressure P2</b> is active	No message relating to <b>Pressure P2</b> is active
Std. Density @ 15 °C	At least one message relating to <b>15 °CStd. Density @</b> is active	No message relating to <b>15 °CStd. Density @</b> is active
Observed Density	At least one message relating to <b>Observed Density</b> is active	No message relating to <b>Observed Density</b> is active
Air Index Warning	At least one message relating to <b>Air Index Warning</b> is active	No message relating to <b>Air Index Warning</b> is active

### 9.6 Modbus TCP Gateway (optional)

This gateway is optional and is used to connect the Off-Loading Flow Computer to other information systems. It is necessary to check whether it is permitted to connect to other systems under the custody transfer regulations.

 For more information, please refer to: →  68



## 10 Operation

### 10.1 Totalizing the transferred quantity

The transferred quantity is calculated using the two non-resettable totalizers, the **Totalizer Off-Loading** and the **Totalizer Reverse**. Depending on the mode of operation of the Off-Loading Flow Computer, only one of the two totalizers is displayed. The transferred quantity **Total Off-Loading** or **Total Reverse** is calculated from the value that these two totalizers display at the start and at the end of an off-loading operation. This totalizer can be set to zero.

### 10.2 Preparing for an off-loading operation

Because of the application, an unread quantity can be totalized during transit (in-transit quantity).

To start a new off-loading operation, the resettable totalizer must be set to zero. When resetting, the system also saves the correct start time of the off-loading operation. You can reset the totalizer either manually via the user interface or remotely via Modbus.

#### NOTICE

**Recording too much data under one batch.**

It might not be possible to create a metering profile (time-out error message).

- ▶ The **Reset Totalizer** function must be executed before the start of an off-loading operation even if the resettable totalizer already shows 0. This ensures that the correct off-loading operation start time is recorded and that the metering profile does not contain unnecessary data.

#### 10.2.1 Manual operation

Proceed as follows to start a new off-loading operation:

1. Make sure the system is ready for the operation. To do so, check the system status, see [Section 11.1](#) →  48.

2. Select the **Batch Control** screen.
  - ↳ The **Batch Control** screen is displayed.

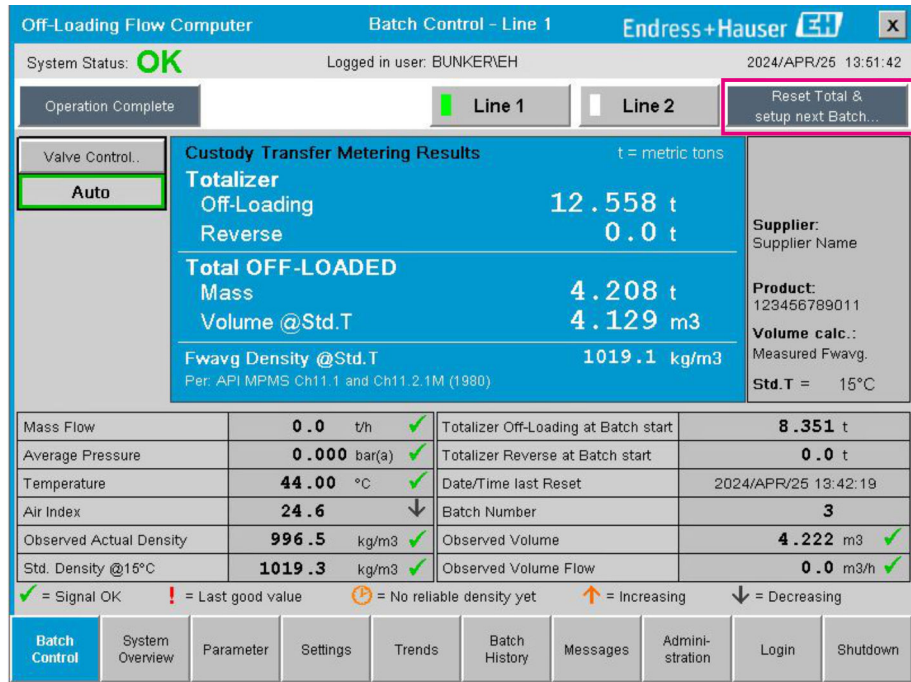

Further course of action if volume measurement has not been enabled.

3. In the **Batch Control** screen, click on the **Reset Total** button.
  - ↳ The following window appears:

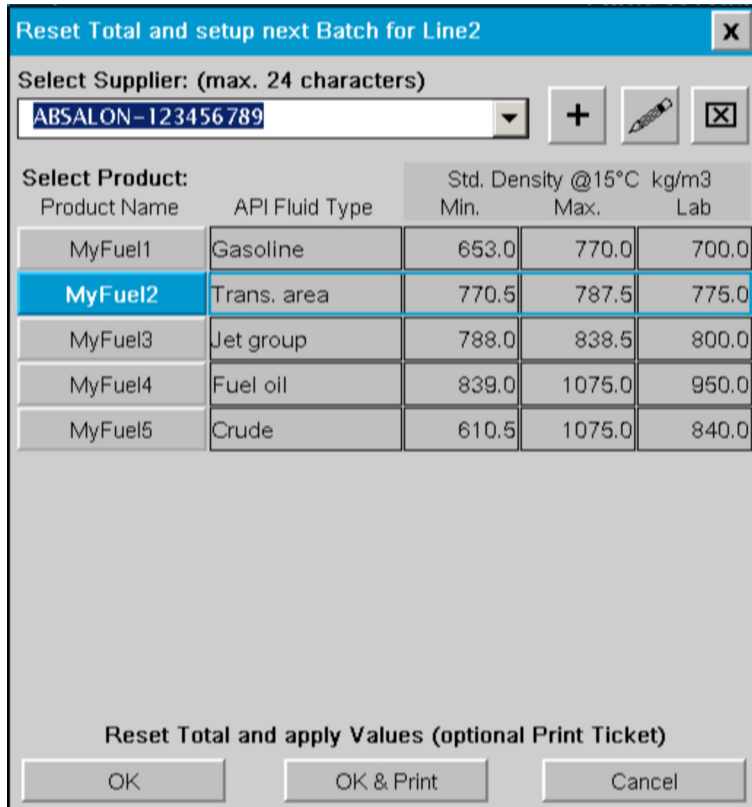

4. Select the supplier and product for the impending off-loading operation.

5. Depending on your requirements, click on the **OK & Print**, **OK** or **Cancel** button.
  - ↳ **OK & Print:** An in-transit metering ticket is printed and the totalizer is reset to "0".
  - OK:** No in-transit metering ticket is printed but the totalizer is reset to "0".
  - Cancel:** The window closes. The totalizer is **not** reset to "0".

**Further course of action if volume measurement has been enabled.**

3. In the **Batch Control** screen, click on the **Reset Total** button.
  - ↳ The following window appears:

**Reset Total and setup next Batch for Line 1**

Select Supplier: (max. 24 characters)  
 BEATRIX-3434343434

Select Product:



Product Name	API Fluid Type	Std. Density @15°C kg/m3		
		Min.	Max.	Lab
MyFuel1	Gasoline	653.0	770.0	700.0
MyFuel2	Trans. area	770.5	787.5	775.0
<b>MyFuel3</b>	<b>Jet group</b>	<b>788.0</b>	<b>838.5</b>	<b>800.0</b>
MyFuel4	Fuel oil	839.0	1075.0	950.0

Select Density to be used for Volume calculations:  
 Fixed Lab Std. Density @15°C  
 Measured Fwavg Std. Density @15°C

**Reset Total and apply Values (optional Print Ticket)**

OK      OK & Print      Cancel

4. Select the supplier and product for the impending off-loading operation.
5. Check the std. density at std. temperature to be used for the selected product and change it if necessary.
6. If the laboratory density is to be used for the entire off-loading operation, select the "Fixed Lab Std. Density" option.

7. Depending on your requirements, click on the **OK & Print**, **OK** or **Cancel** button.
- ↳ **OK & Print:** An in-transit metering ticket is printed and the totalizer is reset to "0".
  - OK:** No in-transit metering ticket is printed but the totalizer is reset to "0".
  - Cancel:** The window closes. The totalizer is **not** reset to "0".
- i** If the "Measured Fwavg Std. Density @Std. Temperature" option is selected, the laboratory density entered is used at the start of the off-loading operation. This laboratory density is used until the system can determine a reliable density. In the **Batch Control** screen, the status "No reliable density yet" is displayed for the relevant values for as long as this is the case.
- i**
- The totalizer **Total Off-Loading / Reverse** is now reset to 0. The Off-Loading Flow Computer is now ready for a new off-loading operation.
  - If an error occurs during printing, the error can be rectified and printing can be started again or canceled, see **Section 12.1** →  51
  - Only one original copy of the in-transit metering ticket can be printed per batch even if the printout was incomplete (e.g. not enough paper in the printer). Once the original in-transit metering ticket has been printed, only duplicate tickets can be printed out. The tickets are marked accordingly.
  - Make sure that sufficient printer paper of the right paper quality is always available, see **Section 12.1.4** →  53





### 10.2.2 Operation via Modbus

Preparing for an off-loading operation via the following Modbus data register:

- 30238 / 30239
- 40007 / 40009
- 40008 / 40010

**i** Modbus data register specification: →  70

### 10.3 Editing the list of suppliers

- i** Use the  button to add more suppliers.
- Use the  button to edit the selected entry.
- Use the  button to delete the selected entry.
- Use the  to delete the last letter or digit.
- Use the  button to delete the entire text.
- The entry is confirmed by selecting **Enter** or discarded by selecting **Cancel**.

1.

**Reset Total and setup next Batch for Line1**

Select Supplier: (max. 24 characters)  
 BEATRIX-3434343434

Product Name	API Fluid Type	Std. Density @15°C kg/m3		
		Min.	Max.	Lab
MyFuel1	Gasoline	653.0	770.0	700.0
MyFuel2	Trans. area	770.5	787.5	775.0
<b>MyFuel3</b>	Jet group	788.0	838.5	<b>800.0</b>
MyFuel4	Fuel oil	839.0	1075.0	950.0

Select Density to be used for Volume calculations:  
 Fixed Lab Std. Density @15°C  
 Measured Fwavg Std. Density @15°C

Reset Total and apply Values (optional Print Ticket)

OK OK & Print Cancel

Click the button.

↳ The **Edit Supplier Name** window appears.

Off-Loading Flow Computer Batch Control - Line1 Endress+Hauser

System Status: OK Reset Total and setup next Batch for Line1

18/MAY/31 08:58:18

Operat Select Supplier: (max. 24 characters) Reset Total & setup next Batch...

Valve BEATRIX-3434343434

Q W E R T Y U I O P 7 8 9  
 A S D F G H J K L 4 5 6  
 Z X C V B N M - Enter 1 2 3  
 Cancel Space 0 .

Supplier: BEATRIX-343434  
 343434  
 Product: MyFuel3  
 Density: Measured Fwavg.  
 Std. T = 15°C

Mass Flow 0.059 t  
 Average Pressure 83.615 t  
 Temperature  
 Air Index 1  
 Observed Actual Dens 0.0 m3 ✓  
 Std. Density @15°C 0.0 m3/h ✓  
 ✓ = Signal OK

Select Density to be used for Volume calculations:  
 Fixed Lab Std. Density @15°C  
 Measured Fwavg Std. Density @15°C

Reset Total and apply Values (optional Print Ticket)

Batch Control System Overview History Station Login Shutdown

OK OK & Print Cancel

2. Edit the supplier and click **Enter**.

The supplier has been changed.

## 10.4 Completing an off-loading operation

You can complete the off-loading operation either manually via the user interface or remotely via Modbus.



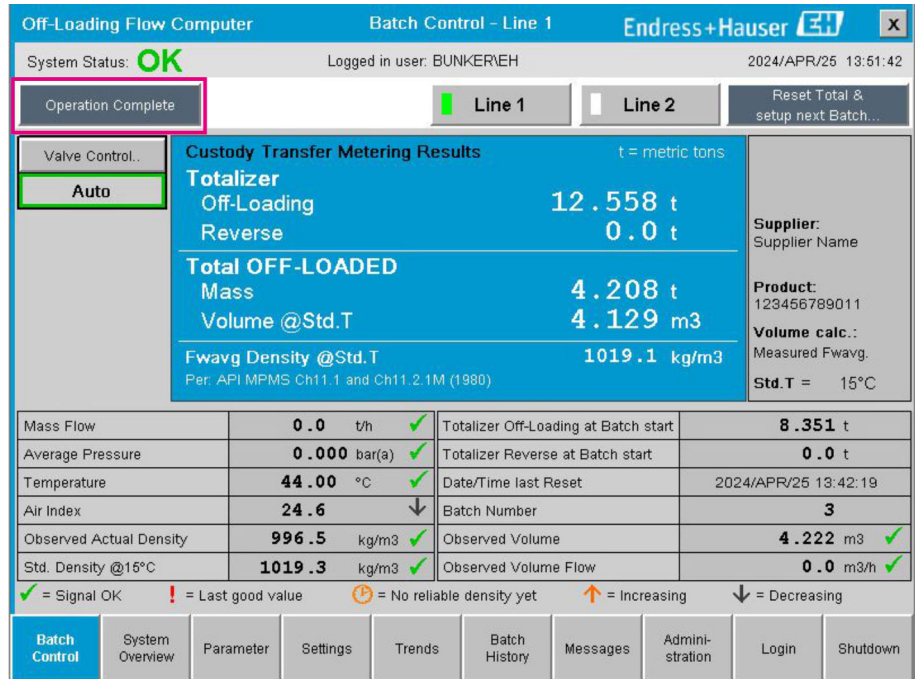

### 10.4.1 Manual operation

1. Select the **Batch Control** screen.
  - ↳ The **Batch Control** screen is displayed.

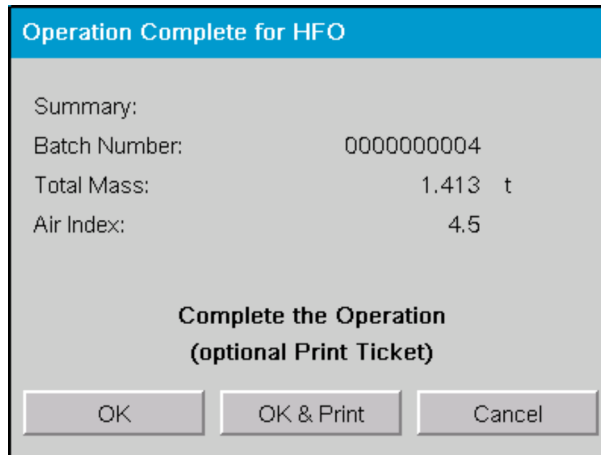

2. If an off-loading operation is complete, click the **Operation Complete** button.
  - ↳ The following window appears. A summary of the batch is displayed.



3. Depending on your requirements, either click on the **OK & Print**, **OK** or **Cancel** button to confirm completion of the current off-loading operation.
  - ↳ **OK & Print:** An off-loading metering ticket is printed and the totalizer is reset to "0".
  - OK:** No off-loading metering ticket is printed but the totalizer is reset to "0".
  - Cancel:** The window closes. The totalizer is **not** reset to "0".
- 
  - If an error occurs during printing, the error can be rectified and printing can be started again or canceled, see **Section 12.1** →  51
  - Only one original copy of the off-loading metering ticket can be printed per batch even if the printout was incomplete (e.g. not enough paper in the printer). Once the original off-loading metering ticket has been printed, only duplicate tickets can be printed. The tickets are marked accordingly.
  - Make sure that sufficient printer paper of the right paper quality is always available, see **Section 12.1.4** →  53
-  The Off-Loading Flow Computer measures, saves and calculates the volumes delivered with high accuracy. All the values indicated on the off-loading metering ticket are also calculated with high accuracy but are rounded off to just three decimal places. If the volume delivered is calculated manually on the basis of these rounded off values, the result can deviate from the result calculated by the Off-Loading Flow Computer.

### 10.4.2 Operation via Modbus

Completing an off-loading operation via the following Modbus data register:

- 30238 / 30239
- 40007 / 40009

 Modbus data register specification: →  70

# 11 Diagnostics and troubleshooting

## 11.1 System status

The overall system status can be one of three categories:

OK	Green	No active error message
WARNING	Yellow	At least one error message in the WARNING category is active but NO error messages in the ERROR category are active
ERROR	Red	At least one error message in the ERROR category is active

## 11.2 Messages













### 11.2.1 Message categories

Messages are divided into two categories:

WARNING	Yellow	An abnormal condition which is not process-critical has been detected.
ERROR	Red	An abnormal condition which is process-critical has been detected. Every message in the <b>Error</b> (alarm) category causes the information <b>Alarms: Yes</b> to appear on the off-loading metering ticket

### 11.2.2 Displaying currently active messages

The error messages that are currently active are listed in the **Messages** screen. Each error contains the time the event occurred and a message text. The following messages are possible:

Warning, not acknowledged	  2015/08/13 12:31:03	New warning
Warning, not acknowledged, resolved	  2015/08/13 14:56:55	Warning which is not active anymore but has not yet been acknowledged
Warning, acknowledged	  2015/08/17 06:57:05	Warning which is still active but has already been acknowledged
Error message, not acknowledged	  2015/08/13 12:31:03	New error message
Error message, not acknowledged, resolved	  2015/08/14 13:25:07	Error message which is not active anymore but has not yet been acknowledged
Error message, acknowledged	  2015/08/17 06:57:06	Error message which is still active but has already been acknowledged



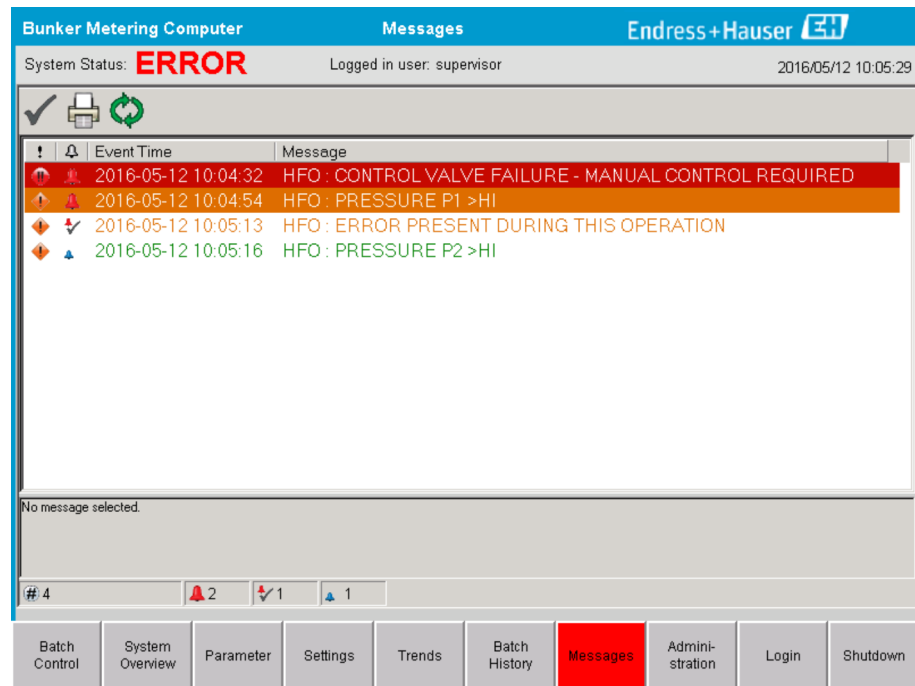

### 11.2.3 Acknowledge messages

Each message must be acknowledged, even if the condition which led to the message is no longer present and the message is therefore no longer active.

- ▶ Select the message in question from the list and click the **Acknowledge** button. Alternatively, double-click the message.

### 11.2.4 List of messages

 An overview of all the possible messages is provided in **Section 15.1**.

## 11.3 Ticket printer

If an error occurs during printing, the ticket printer displays the word "Error" and an error message. If the printer has run out of paper, the message "Error: Out of Paper" is displayed. New printer paper has to be inserted if this message appears, see **Section 12.1.1**.

→  51

 If an error occurs during printing, the error can be rectified and printing can be started again or canceled.

The paper roll must be replaced if the markings (red stripes) indicating the end of the paper roll are visible. **Section 12.1.1** →  51

## 11.4 Broken wire signal

 If messages indicating a wire break are displayed, an authorized electrician must check the wiring of the device using the wiring diagram supplied with the system.

## 11.5 Power failure

If a power failure has occurred, the system displays the following messages after restart:

- LINE 1: POWER UP OF CONTROLLER
- LINE 2: POWER UP OF CONTROLLER (optional)
- CONNECTION BETWEEN HMI AND PLC INTERRUPTED

These messages must be acknowledged before you can continue with the next batch. A **Reset Total** (see **Section 10.2** ) must be performed before the next off-loading operation to ensure that the new measurement is not added to the previous measurement.

## 11.6 Batch result too high

If the result displayed by the Off-Loading Flow Computer after an off-loading operation is higher than other reference measurements, it is necessary to check whether the resettable totalizer (batch totalizer) was reset to zero via the **Reset Total** button before the start of the off-loading operation (see **Section 10.2** ).

## 12 Maintenance

### 12.1 Ticket printer

#### 12.1.1 Replacing the paper roll

The printer is designed for a paper width of  $57.5 \pm 0.5$  mm, and a paper weight of 60 g/m<sup>2</sup>. Other types of paper might not be suitable. See **Section 12.1.4** →  53 for ordering information.

#### 12.1.2 Inserting the paper roll

Use paper rolls which are coated on the outside with a width of  $57.5 \pm 0.5$  mm and a maximum winding diameter of 60 mm for GPT-4344. Standard paper: paper type: GPR-T01-057-031-007-060A (available from Endress+Hauser – order number: 71293016)

1.



Unwind 10 cm of paper from the roll, making sure that the rest of the roll remains wound tightly.

2.



Press the lever inside the lid slightly upwards. The print roll is lifted out of the printer mechanism along with the lid.

↳ The printer cover can now be opened.

3.



Insert the new paper roll into the paper compartment, ensuring that the outside faces toward the printer mechanism. This is the only printable side.

4.



Apply some pressure to close the lid.

- ↳ The cover snaps into place with an audible click. The paper can be torn off at the tear-off edge without having to reopen the cover or without the paper sliding through the print head.

### 12.1.3 Cleaning

**i** After larger print jobs, it may be necessary to clean the print head, the sensor and platen roller depending on the paper quality and unfavorable environmental conditions. This is particularly true if some areas are no longer printed correctly.

Never use sharp objects to clean the printer, as this could damage the print head.

1. Open the cover of the paper feed and remove the paper roll.
2. Using a small brush (e.g. cotton bud) remove any dirt particles on the paper sensor and the tear-off edge.
3. Blow forcefully into the paper feed compartment in order to remove larger dust particles.
4. Soak a cleaning swab in isopropanol (IPA) and clean the print head. A cleaning pen or cleaning card can also be used.
5. Clean stubborn dirt with a soaked cleaning swab also.

### 12.1.4 Service and replacement

Printer paper or a new printer can be ordered from Endress+Hauser. For more information on spare parts, please contact your Endress+Hauser Sales Center.

 Standard paper: paper type: GPR-T01-057-031-007-060A (available from Endress+Hauser – order number: 71293016)

Printer: special version (available from Endress+Hauser - order number: 71293014)

## 12.2 Display on operating panel

### Cleaning the display:

1. Disconnect the power supply to the computer directly at the power source.
2. Clean the display using a mild soap or a mild cleaning agent and a clean sponge or a soft cloth.
3. To avoid water marks, dry the display with a leather cloth or a moist cellulose sponge.

-  If the computer has a touch display and the computer is switched on during cleaning, objects on the display may be activated while the devices are being cleaned.
- The use of abrasive cleaners or solutions can damage the display window. Do not scrub the display or use brushes to clean it.

## 12.3 Cabinet fan

The filter mat of the cabinet fan must be checked periodically. Where necessary, the filter mat must be cleaned or replaced with the following type of mat: Rittal filter mats SK 3322.700.

## 12.4 System maintenance

It is advisable to have the Off-Loading Metering System regularly serviced by the system supplier.

For more information, please contact your Endress+Hauser Sales Center at [www.address.endress.com](http://www.address.endress.com)

## 13 Repair

### 13.1 General notes

- Replace the following entirely in the event of an error:
  - All inexpensive components
- Use only original spare parts
- Observe all the applicable standards, regional/national laws, certificates and the sealing of the SBC600
- Document all repairs and enter them in the W@M Lifecycle Management database
- Repairs may be carried out only by Endress+Hauser service employees or by suitably trained customer staff

### 13.2 Spare parts and services

Please contact your Endress+Hauser Sales Center at: [www.addresses.endress.com](http://www.addresses.endress.com)

## 14 Technical data

The SBC600 can be supplied with a choice of three cabinet configurations:

- Single cabinet with the PLC and HMI in the same cabinet (control unit) for wall mounting
- Two cabinets with the PLC (control unit) and HMI (operator terminal) in separate cabinets for wall mounting
- Two cabinets with the PLC (control unit) in one cabinet for wall mounting and the HMI (operator terminal) in a desk panel

Unless otherwise specified, the following technical data apply for all cabinet configurations.

### 14.1 Power supply

Control unit:	220 to 240 VAC, 50 to 60 Hz, 250 VA
Operator terminal:	220 to 240 VAC, 50 to 60 Hz, 120 VA

### 14.2 Input/output

Flowmeter:	Pulse 24 VDC, Modbus RTU
Temperature:	Current signal 4 to 20 mA
Pressure:	2x current signal 4 to 20 mA
Control valve:	1x control signal 4 to 20 mA, 1x feedback signal 4 to 20 mA

### 14.3 Environment

*Operating environment for cabinets of the Off-Loading Flow Computer:*

Ambient temperature range:	-10 to 55 °C
Relative humidity:	25 to 75 %

## 15 Appendix

### 15.1 Messages list

Message number	Message text	Delay time	Message category	Cause	Visual system reaction	Function system reaction	Application	Recommended action
1	COMMUNICATION BETWEEN HMI AND PLC INTERRUPTED	10 s	Alarm	Communication error with PLC	Message	-	Global	Check Ethernet communication cable between operating panel and control unit (only possible if housing open).
2	PARAMETER SWITCH IN UNSEALED POSITION	0 s	Warning	Custody transfer switch has been set to unsealed position	Message	Custody transfer switch can be changed	Global	Set custody transfer parameter switch to <b>Sealed</b> position.
3	CONTROL CABINET DOOR OPENED	0 s	Warning	Cabinet door has been opened	Message	-	Global	Close cabinet door.
4	POWER SUPPLY 1 POWER FAILURE	5 s	Warning	Power unit 1 power failure	Message	-	Global	Check power supply.
5	POWER SUPPLY 2 POWER FAILURE	5 s	Warning	Power unit 2 power failure	Message	-	Global	Check power supply.
6	COMMUNICATION ERROR WITH EXTERNAL DATA LOGGER	10 s	Warning	Communication error with external data logger	Message	-	Global	Check serial communication cable between control unit and external data logger (only possible if housing open).
7	I/O MODULE FAULT - SEE DIAGNOSTIC INFORMATION FOR DETAILS	0 s	Alarm	Hardware error	Message	-	Global	Check connection between the PLC and the I/O modules.
8	MODBUS GATEWAY I/O FAULT	10 s	Warning	Hardware error Module is missing	Message	-	Global	Check connection between PLC and Anybus Modbus gateway.
9	CONTROLLER MAJOR FAULT - SEE DIAGNOSTIC INFO	0 s	Alarm	Software error	Message	-	Global	See Diagnostic Information screen: contact Endress+Hauser
101	LINE 1: MASS FLOW F1 <LO	5 s	Warning	Mass flow lower than LO limit	Message	-	Line 1	Check process conditions.



Message number	Message text	Delay time	Message category	Cause	Visual system reaction	Function system reaction	Application	Recommended action
102	LINE 1: MASS FLOW F1 >HI	5 s	Warning	Mass flow higher than HI limit	Message	-	Line 1	Check process conditions.
103	LINE 1: TEMPERAT URE T1 <LO	5 s	Warning	Temperature lower than LO limit	Message	-	Line 1	Check process conditions.
104	LINE 1: TEMPERAT URE T1 >HI	5 s	Warning	Temperature higher than HI limit	Message	-	Line 1	Check process conditions.
105	LINE 1: TEMPERAT URE T1 - DEVICE ERROR	5 s	Alarm	Temperature T1 device error or signal cable wire break	Message	Continuous measurement	Line 1	Check device or sensor signal cable.
106	LINE 1: PRESSURE P1 <LO	5 s	Warning	Pressure P1 lower than LO limit	Message	-	Line 1	Check process conditions.
107	LINE 1: PRESSURE P1 >HI	5 s	Warning	Pressure P1 higher than HI limit	Message	-	Line 1	Check process conditions.
108	LINE 1: PRESSURE P1 - DEVICE ERROR	5 s	Alarm	Pressure P1 device error or signal cable wire break	Message	<ul style="list-style-type: none"> <li>▪ Continuous measurement</li> <li>▪ VFR operating mode not available</li> <li>▪ Barge installation: Control valve operating mode changes if a switch is made from automatic to manual in the loading mode</li> </ul>	Line 1	Check device or sensor signal cable.
109	LINE 1: PRESSURE P2 <LO	5 s	Warning	Pressure P2 lower than LO limit	Message	-	Line 1	Check process conditions.
110	LINE 1: PRESSURE P2 >HI	5 s	Warning	Pressure P2 higher than HI limit	Message	-	Line 1	Check process conditions.

Message number	Message text	Delay time	Message category	Cause	Visual system reaction	Function system reaction	Application	Recommended action
111	LINE 1: PRESSURE P2 - DEVICE ERROR	5 s	Alarm	Pressure P2 device error or signal cable wire break	Message	<ul style="list-style-type: none"> <li>▪ Continuous measurement</li> <li>▪ VFR operating mode not available</li> <li>▪ Barge installation: Control valve operating mode changes if a switch is made from automatic to manual in the loading mode</li> </ul>	Line 1	Check device or sensor signal cable.
112	LINE 1: CONTROL VALVE FEEDBACK - BROKEN WIRE	5 s	Warning	Valve message: wire break/ short-circuit	<ul style="list-style-type: none"> <li>▪ Message</li> <li>▪ System shows the last valid value</li> </ul>	-	Line 1	Check control valve wiring of feedback signal.
113	LINE 1: CONTROL VALVE FAILURE - MANUAL CONTROL REQUIRED	5 s	Alarm	Difference detected in valve control and feedback signal	Message	<ul style="list-style-type: none"> <li>▪ Continuous measurement</li> <li>▪ Control valve operating mode changes from automatic to manual</li> </ul>	Line 1	Check the wiring and proper operation of the control valve. If the valve does not respond, manual control using the hand-wheel is necessary!
114	LINE 1: MODBUS - COMMUNIC ATION FAILURE TO FLOWMETE R	10 s	Alarm	Modbus connection to flowmeter interrupted	<ul style="list-style-type: none"> <li>▪ Message</li> <li>▪ System shows the last valid value</li> </ul>	<ul style="list-style-type: none"> <li>▪ Continuous measurement</li> <li>▪ System switches to the VFR measuring mode (if available)</li> </ul>	Line 1	Check Modbus signal cable of flowmeter. Primary measuring mode inaccurate. Auxiliary measurement takes over.

Message number	Message text	Delay time	Message category	Cause	Visual system reaction	Function system reaction	Application	Recommended action
115	LINE 1: FLOWMETER PULSE LINE FAILURE	5 s	Alarm	Broken wire of pulse signal (deviation compared with the flow value transmitted via Modbus for more than 5 seconds, loading or delivery active, Promass Status =1. The deviation can be configured.)	Message	<ul style="list-style-type: none"> <li>▪ Continuous measurement</li> <li>▪ System totalizes with Modbus flow value</li> </ul>	Line 1	Check pulse line cable of flowmeter. Modbus process values are taken into account.
116	LINE 1: FLOWMETER FAILURE	5 s	Alarm	Modbus connection of flowmeter and pulse signal failed	<ul style="list-style-type: none"> <li>▪ Message</li> <li>▪ System shows the last valid value (Modbus)</li> </ul>	<ul style="list-style-type: none"> <li>▪ Continuous measurement</li> <li>▪ System switches to the VFR measuring mode (if available)</li> </ul>	Line 1	Check Modbus and pulse line cable of flowmeter. Auxiliary measurement takes over.
117	LINE 1: POWER UP OF CONTROLLER CAUSED BY POWER FAILURE	0 s	Alarm		Controller power failure	Alarm, power failure indicated on BMT	Line 1	Message is automatically hidden when next batch starts. After startup, the system automatically continues with the measurements.
118	LINE 1: VFR MEASURING MODE NOT AVAILABLE	5 s	Alarm	Broken wire detected at P1 and/or P2	Message	System does not switch to the VFR measuring mode	Line 1	Check signal cable of sensors P1 and P2. Not possible to switch to auxiliary measuring mode.
119	LINE 1: FLOWMETER MEASURING MODE NOT AVAILABLE	5 s	Alarm	Modbus communication error to flowmeter or flowmeter status not OK	Message	System does not switch flowmeter to measuring mode	Line 1	Check Modbus and pulse line cable, or status of flowmeter. Auxiliary measurement takes over.
120	LINE 1: NO MEASURING MODE AVAILABLE	5 s	Alarm	VFR measuring mode and flowmeter measuring mode cannot be accessed	Message	System shows the last valid value. Totalization can be stopped manually.	Line 1	See additional detailed messages.

Message number	Message text	Delay time	Message category	Cause	Visual system reaction	Function system reaction	Application	Recommended action
121	LINE 1: AIR INDEX IS ABOVE CRITICAL VALUE	See settings	Warning	<b>Air Index</b> is higher than EU 0.5% limit	Message	None	Line 1	Too much air in the bunker pipe/off-loading pipe.
122	LINE 1: WARNING: AIR INDEX HIGH, TAKE STEPS FOR REDUCTION OF ENTRAINED AIR	0 s	Warning	<b>Air Index</b> is higher than Air Index limit (adjustable)	Message	None	Line 1	Too much air in the bunker pipe/off-loading pipe.
123	LINE 1: STANDARD DENSITY OUT OF RANGE (LOW LIMIT)	10 s	Warning	<b>Standard Density</b> lower than lower limit (adjustable)	Message	None	Line 1	Check process conditions.
124	LINE 1: STANDARD DENSITY OUT OF RANGE (HIGH LIMIT)	10 s	Warning	<b>Standard Density</b> higher than upper limit (adjustable)	Message	None	Line 1	Check process conditions.
125	LINE 1: OBSERVED DENSITY OUT OF RANGE (LOW LIMIT)	10 s	Warning	<b>Observed Density</b> lower than lower limit (adjustable)	Message	None	Line 1	Check process conditions.
126	LINE 1: OBSERVED DENSITY OUT OF RANGE (HIGH LIMIT)	10 s	Warning	<b>Observed Density</b> higher than upper limit (adjustable)	Message	None	Line 1	Check process conditions.
127	LINE 1: PRESSURE P1 >HIHI (ACKNOWLEDGMENT REQUIRED!)	1 s	Alarm	Pressure P1 higher than HIHI limit	Message	Control valve fully opened in manual mode	Line 1	Reduce the pressure immediately (reduce pump speed, open valve). The valve only returns to the automatic control mode if this message has been acknowledged.

Message number	Message text	Delay time	Message category	Cause	Visual system reaction	Function system reaction	Application	Recommended action
128	LINE 1: PRESSURE P2 >HIHI (ACKNOWLEDGEMENT REQUIRED!)	1 s	Alarm	Pressure P2 higher than HIHI limit	Message	Control valve fully opened in manual mode	Line 1	Reduce the pressure immediately (reduce pump speed, open valve). The valve only returns to the automatic control mode if this message has been acknowledged.
129	LINE 1: ERROR PRESENT DURING THIS OPERATION	0 s	Warning	At least 1 message with Level Alarm active during this operation	Message	None	Line 1	The message is hidden automatically when the next <b>Reset Total</b> or <b>Operation Complete</b> is performed.
131	LINE 1: PROMASS CUSTODY TRANSFER LOGBOOK FULL	0 s	Alarm	Custody transfer logbook of the Promass 300 is full	Message	None	Line 1	1. Deactivate custody transfer mode 2. Delete custody transfer logbook (all 30 entries) 3. Activate custody transfer mode.
132	LINE1: PROMASS STATUS	0 s	Alarm	Promass status not ok	Message	<ul style="list-style-type: none"> <li>▪ Continuous measurement</li> <li>▪ System switches to the VFR measuring mode (if available)</li> </ul>	Line1	Check the Promass status and rectify the problem according to the Operating Instructions of the Promass.
201	LINE 2: MASS FLOW F1 <LO	5 s	Warning	Mass flow lower than LO limit	Message	-	Line 2	Check process conditions.
202	LINE 2: MASS FLOW F1 >HI	5 s	Warning	Mass flow higher than HI limit	Message	-	Line 2	Check process conditions.
203	LINE 2: TEMPERAT URE T1 <LO	5 s	Warning	Temperature lower than LO limit	Message	-	Line 2	Check process conditions.
204	LINE 2: TEMPERAT URE T1 >HI	5 s	Warning	Temperature higher than HI limit	Message	-	Line 2	Check process conditions.
205	LINE 2: TEMPERAT URE T1 - DEVICE ERROR	5 s	Alarm	Temperature T1 device error or signal cable wire break	Message	Continuous measurement	Line 2	Check device or sensor signal cable.
206	LINE 2: PRESSURE P1 <LO	5 s	Warning	Pressure P1 lower than LO limit	Message	-	Line 2	Check process conditions.

Message number	Message text	Delay time	Message category	Cause	Visual system reaction	Function system reaction	Application	Recommended action
207	LINE 2: PRESSURE P1 >HI	5 s	Warning	Pressure P1 lower than HI limit	Message	-	Line 2	Check process conditions.
208	LINE 2: PRESSURE P1 - DEVICE ERROR	5 s	Alarm	Pressure P1 device error or signal cable wire break	Message	<ul style="list-style-type: none"> <li>■ Continuous measurement</li> <li>■ VFR operating mode not available</li> <li>■ Barge installation: Control valve operating mode changes if a switch is made from automatic to manual in the loading mode</li> </ul>	Line 2	Check device or sensor signal cable.
209	LINE 2: PRESSURE P2 <LO	5 s	Warning	Pressure P2 lower than LO limit	Message	-	Line 2	Check process conditions.
210	LINE 2: PRESSURE P2 >HI	5 s	Warning	Pressure P2 higher than HI limit	Message	-	Line 2	Check process conditions.
211	LINE 2: PRESSURE P2 - DEVICE ERROR	5 s	Alarm	Pressure P2 device error or signal cable wire break	Message	<ul style="list-style-type: none"> <li>■ Continuous measurement</li> <li>■ VFR operating mode not available</li> <li>■ Vessel installation: Control valve operating mode changes if a switch is made from automatic to manual in the loading mode</li> </ul>	Line 2	Check device or sensor signal cable.
212	LINE 2: CONTROL VALVE FEEDBACK – BROKEN WIRE	5 s	Warning	Valve message: wire break/ short-circuit	<ul style="list-style-type: none"> <li>■ Message</li> <li>■ System shows the last valid value</li> </ul>	--	Line 2	Check control valve wiring of feedback signal.
213	LINE 2: CONTROL VALVE FAILURE - MANUAL CONTROL REQUIRED	5 s	Alarm	Difference detected in valve control and feedback signal	Message	<ul style="list-style-type: none"> <li>■ Continuous measurement</li> <li>■ Control valve operating mode changes from automatic to manual</li> </ul>	Line 2	Check the wiring and proper operation of the control valve. If the valve does not respond, manual control using the hand-wheel is necessary!

Message number	Message text	Delay time	Message category	Cause	Visual system reaction	Function system reaction	Application	Recommended action
214	LINE 2: MODBUS – COMMUNIC ATION FAILURE TO FLOWMETER	10 s	Alarm	Modbus connection to flowmeter interrupted	<ul style="list-style-type: none"> <li>▪ Message</li> <li>▪ System shows the last valid value</li> </ul>	<ul style="list-style-type: none"> <li>▪ Continuous measurement</li> <li>▪ System switches to the VFR measuring mode (if available)</li> </ul>	Line 2	Check Modbus signal cable of flowmeter. Primary measuring mode inaccurate. Auxiliary measurement takes over.
215	LINE 2: FLOWMETER PULSE LINE FAILURE	5 s	Alarm	Broken wire of pulse signal (deviation compared with the flow value transmitted via Modbus for more than 5 seconds, loading or delivery active, Promass Status =1. The deviation can be configured.)	Message	<ul style="list-style-type: none"> <li>▪ Continuous measurement</li> <li>▪ System totalizes with Modbus flow value</li> </ul>	Line 2	Check pulse line cable of flowmeter. Modbus process values are taken into account.
216	LINE 2: FLOWMETER FAILURE	5 s	Alarm	Modbus connection of flowmeter and pulse signal failed	<ul style="list-style-type: none"> <li>▪ Message</li> <li>▪ System shows the last valid value (Modbus)</li> </ul>	<ul style="list-style-type: none"> <li>▪ Continuous measurement</li> <li>▪ System switches to the VFR measuring mode (if available)</li> </ul>	Line 2	Check Modbus and pulse line cable of flowmeter. Auxiliary measurement takes over.
217	LINE 2: POWER UP OF CONTROLLE R CAUSED BY POWER FAILURE	0 s	Alarm		Controller power failure	Alarm, power failure indicated on BMT	Line 2	Message is automatically hidden when next batch starts. After startup, the system automatically continues with the measurements.
218	LINE 2: VFR MEASURING MODE NOT AVAILABLE	5 s	Alarm	Broken wire detected at P1 and/or P2	Message	System does not switch to the VFR measuring mode	Line 2	Check signal cable of sensors P1 and P2. Not possible to switch to auxiliary measuring mode.

Message number	Message text	Delay time	Message category	Cause	Visual system reaction	Function system reaction	Application	Recommended action
219	LINE 2: FLOWMETER MEASURING MODE NOT AVAILABLE	5 s	Alarm	Modbus communication error to flowmeter or flowmeter status not OK	Message	System does not switch flowmeter to measuring mode	Line 2	Check Modbus and pulse line cable, or status of flowmeter. Auxiliary measurement takes over.
220	LINE 2: NO MEASURING MODE AVAILABLE	5 s	Alarm	VFR measuring mode and flowmeter measuring mode cannot be accessed	Message	System shows the last valid value. Totalization can be stopped manually.	Line 2	See additional detailed messages.
221	LINE 2: AIR INDEX IS ABOVE CRITICAL VALUE	See settings	Warning	<b>Air Index</b> is higher than EU 0.5% limit	Message	None	Line 2	Too much air in the bunker pipe/off-loading pipe.
222	LINE 2: WARNING: AIR INDEX HIGH, TAKE STEPS FOR REDUCTION OF ENTRAINED AIR	0 s	Warning	<b>Air Index</b> is higher than Air Index limit (adjustable)	Message	None	Line 2	Too much air in the bunker pipe/off-loading pipe.
223	LINE 2: STANDARD DENSITY OUT OF RANGE (LOW LIMIT)	10 s	Warning	<b>Standard Density</b> lower than lower limit (adjustable)	Message	None	Line 2	Check process conditions.
224	LINE 2: STANDARD DENSITY OUT OF RANGE (HIGH LIMIT)	10 s	Warning	<b>Standard Density</b> higher than upper limit (adjustable)	Message	None	Line 2	Check process conditions.
225	LINE 2: OBSERVED DENSITY OUT OF RANGE (LOW LIMIT)	10 s	Warning	<b>Observed Density</b> lower than lower limit (adjustable)	Message	None	Line 2	Check process conditions.
226	LINE 2: OBSERVED DENSITY OUT OF RANGE (HIGH LIMIT)	10 s	Warning	<b>Observed Density</b> higher than upper limit (adjustable)	Message	None	Line 2	Check process conditions.



Message number	Message text	Delay time	Message category	Cause	Visual system reaction	Function system reaction	Application	Recommended action
227	LINE 2: PRESSURE P1 >HIHI (ACKNOWLEDGEMENT REQUIRED!)	1 s	Alarm	Pressure P1 higher than HIHI limit	Message	Control valve fully opened in manual mode	Line 2	Reduce the pressure immediately (reduce pump speed, open valve). The valve only returns to the automatic control mode if this message has been acknowledged.
228	LINE 2: PRESSURE P2 >HIHI (ACKNOWLEDGEMENT REQUIRED!)	1 s	Alarm	Pressure P2 higher than HIHI limit	Message	Control valve fully opened in manual mode	Line 2	Reduce the pressure immediately (reduce pump speed, open valve). The valve only returns to the automatic control mode if this message has been acknowledged.
229	LINE 2: ERROR PRESENT DURING THIS OPERATION	0 s	Warning	At least 1 message with Level Alarm active during this operation	Message	None	Line 2	The message is hidden automatically when the next <b>Reset Total</b> or <b>Operation Complete</b> is performed.
231	LINE 2: PROMASS CUSTODY TRANSFER LOGBOOK FULL	0 s	Alarm	Custody transfer logbook of the Promass 300 is full	Message	None	Line 2	1. Deactivate custody transfer mode 2. Delete custody transfer logbook (all 30 entries) 3. Activate custody transfer mode.
232	LINE 2: PROMASS STATUS	0 s	Alarm	Promass status not ok	Message	<ul style="list-style-type: none"> <li>▪ Continuous measurement</li> <li>▪ System switches to the VFR measuring mode (if available)</li> </ul>	Line 2	Check the Promass status and rectify the problem according to the Operating Instructions of the Promass.

## 15.2 Sealing/locking

### 15.2.1 Sealing program settings

The settings of the SBC600 are sealed by a hardware switch inside the control cabinet. If this switch is set to **Sealed**, it is not possible to modify any settings that are relevant for custody transfer. If the switch is set to **Unsealed**, an error message appears on the HMI.

### 15.2.2 Sealing cabinets

The cable entries of the system cabinets must be protected against unauthorized access. The plates with the cable entries are secured with sealing screws. These screws must be sealed as shown in the figure below:



25 Location of the cable entries



26 Screws sealed with sealing wire

After commissioning the system, the door locks can be sealed as shown in the figure below:

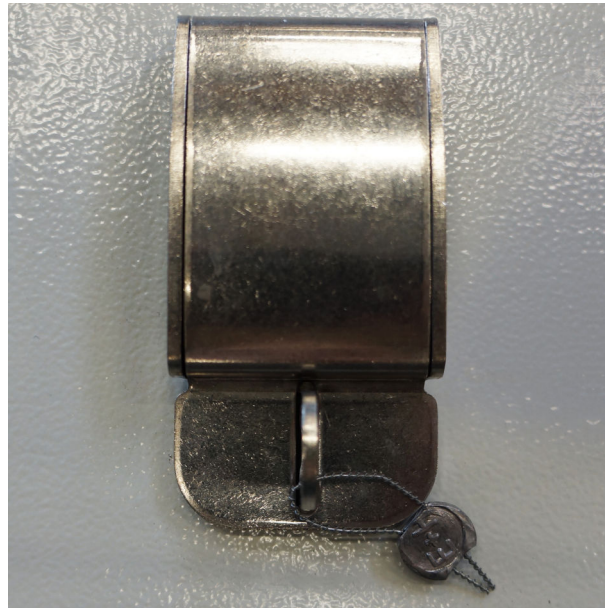

### 15.2.3 USB ports

If all access to the system is prohibited, the USB ports on the operating panel must be sealed as shown in the figures below.

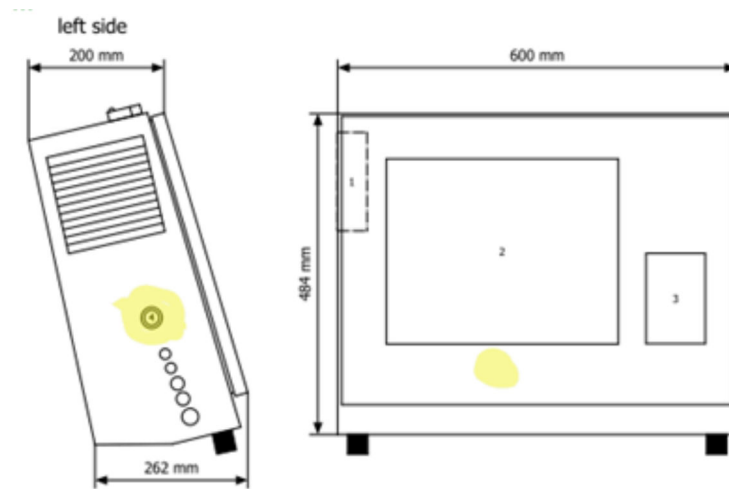

27 Location of the USB port



28 USB port sealed with sealing wire

## 15.3 Interface specification

This section describes the Modbus TCP interface between the SBC600 and the external system. Modbus is compatible with all versions of the SBC600 software that have installed an Anybus Modbus TCP Gateway. Not all SBC600 software versions have all the values. The SBC600 application version must be known before the TCP interface is implemented.

### 15.3.1 Modbus TCP

#### IP default settings

IP address:	10.126.97.48
Subnet mask:	255.255.255.0
Port:	502

The IP configuration of the Anybus Modbus TCP network interface can be edited using the IPconfig tool. The IPconfig tool can be downloaded from [www.anybus.com](http://www.anybus.com).

#### Definitions

The SBC600 acts as a Modbus server/slave, while the third-party system is the Modbus client/master. The register addresses indicated in this document are 1-based in accordance with the Modbus data model.

#### Modbus function codes

The following Modbus function codes are supported:

Function code	Function name	Meaning
04	Read Input Registers (3xxxx)	Read interrelated registers 1-125
06	Write Single Register (4xxxx)	Write 1 register

#### Floating-point number

Floating point number as per IEEE 754:

Byte 3	Byte 2	Byte 1	Byte 0
SEEEEEEE	EMMMMMMM	MMMMMMMM	MMMMMMMM

S = sign  
 E = exponent  
 M = mantissa

Byte transmission sequence (little endian):

1.	2.	3.	4.
Byte 0	Byte 1	Byte 2	Byte 3

Byte transmission sequence (big endian):

1.	2.	3.	4.
Byte 1	Byte 0	Byte 3	Byte 2

### String values

Examples of string values (system ID, register 30215, max. 20 characters) with the value "abcd 1234":

Register 30224			Register 30219		Register 30218		Register 30217		Register 30216		Register 30215	
Byte 19	Byte 18	...	Byte 9	Byte 8	Byte 7	Byte 6	Byte 5	Byte 4	Byte 3	Byte 2	Byte 1	Byte 0
"NUL" <sup>1)</sup>	"NUL"	...	"NUL"	"4"	"3"	"2"	"1"	" "	"d"	"c"	"b"	"a"
0x00	0x00	...	0x00	0x34	0x33	0x32	0x31	0x20	0x64	0x63	0x62	0x61

1) Bytes that are not used are populated with "NUL" and ignored by the target system.

Byte transmission sequence (little endian):

1.	2.	...	19.	20.
Byte 0	Byte 1	...	Byte 18	Byte 19

Byte transmission sequence (big endian):

1.	2.	...	19.	20.
Byte 1	Byte 0	...	Byte 19	Byte 18

### Integer values (16-bit)

Byte transmission sequence (little endian):

1.	2.
Byte 0	Byte 1

Byte transmission sequence (big endian):

1.	2.
Byte 1	Byte 0

**Integer values (32-bit)***Byte transmission sequence (little endian):*

1.	2.	3.	4.
Byte 0	Byte 1	Byte 2	Byte 3

*Byte transmission sequence (big endian):*

1.	2.	3.	4.
Byte 1	Byte 0	Byte 3	Byte 2

**15.3.2 Modbus data register specification**

The following data does not refer to a specific SBC600 line.

**Global data***Modbus watchdog*

Modbus register:	40001	Watchdog signal received from the master.
Register count value:	1	
Data type:	Integer (16-bit signed)	
Access:	Write	
SBC600 software version:	All	

*Modbus watchdog*

Modbus register:	30001	The watchdog signal received from the master is sent back to the client (copied from the Write tag to the Read tag). The client should check the watchdog signal for uninterrupted communication.
Register count value:	1	
Data type:	Integer (16-bit signed)	
Access:	Read	
SBC600 software version:	All	

*Vessel ID 1<sup>st</sup> line*

Modbus register:	30002	User-configurable vessel ID (1st text line). Can be used for IMO number.
Register count value:	10	
Data type:	String (20)	
Access:	Read	
SBC600 software version:	All	

*Vessel ID 2<sup>nd</sup> line*

Modbus register:	30205	User-configurable vessel ID (2nd text line).
Register count value:	10	
Data type:	String (20)	
Access:	Read	
SBC600 software version:	All	

*System ID*

Modbus register:	30215	SBC600 system ID (not customizable).
Register count value:	10	
Data type:	String (20)	
Access:	Read	
SBC600 software version:	All	

*SBC600 error status - global*

Modbus register:	30012	Bitwise SBC600 error status as per the following table (for message numbers, see the Operating Instructions).		
Register count value:	1			
Data type:	Integer			
Access:	Read			
Bit 0:	-	No active error message	(1=no error)	All software versions
Bit 1:	-	No warning active	(1=no warning)	All software versions
Bit 2:	001	COMMUNICATION BETWEEN HMI AND PLC INTERRUPTED	(1=active)	All software versions
Bit 3:	002	PARAMETER SWITCH IN <b>UNSEALED</b> POSITION	(1=active)	All software versions
Bit 4:	003	CONTROL CABINET DOOR OPENED	(1=active)	All software versions
Bit 5:	004	POWER SUPPLY 1 POWER FAILURE	(1=active)	All software versions
Bit 6:	005	POWER SUPPLY 2 POWER FAILURE	(1=active)	All software versions
Bit 7:	006	COMMUNICATION ERROR WITH EXTERNAL DATA LOGGER	(1=active)	All software versions
Bit 8:	007	I/O MODULE FAULT - SEE DIAGNOSTIC INFORMATION FOR DETAILS	(1=active)	V1.04.00 and higher
Bit 9:	008	MODBUS GATEWAY I/O FAULT	(1=active)	V1.04.00 and higher
Bit 10:	009	CONTROLLER MAJOR FAULT - SEE DIAGNOSTIC INFO	(1=active)	V1.05.00 and higher

**Line-specific SBC600 data**

The following data apply specifically to the SBC600 line.

*SBC600 error status - line-specific*

Modbus register:	Line 1: 30014, 30015 Line 2: 30069, 30070	Bitwise SBC600 error status as per the following table (for message numbers, see the Operating Instructions).		
Register count value:	2			
Data type:	Integer			
Access:	Read			
<b>Register 1:</b>				
Bit 0:	101/201	MASS FLOW F1 < LO	(1=active)	All software versions
Bit 1:	102/202	MASS FLOW F1 > HI	(1=active)	All software versions

Bit 2:	103/203	TEMPERATURE T1 < LO	(1=active)	All software versions
Bit 3:	104/204	TEMPERATURE T1 > HI	(1=active)	All software versions
Bit 4:	105/205	TEMPERATURE T1 - DEVICE ERROR	(1=active)	All software versions
Bit 5:	106/206	PRESSURE P1 < LO	(1=active)	All software versions
Bit 6:	107/207	PRESSURE P1 > HI	(1=active)	All software versions
Bit 7:	108/208	PRESSURE P1 - DEVICE ERROR	(1=active)	All software versions
Bit 8:	109/209	PRESSURE P2 < LO	(1=active)	All software versions
Bit 9:	110/210	PRESSURE P2 > HI	(1=active)	All software versions
Bit 10:	111/211	PRESSURE P2 - DEVICE ERROR	(1=active)	All software versions
Bit 11:	112/212	CONTROL VALVE FEEDBACK - BROKEN WIRE	(1=active)	All software versions
Bit 12:	113/213	CONTROL VALVE FAILURE - MANUAL CONTROL REQUIRED	(1=active)	All software versions
Bit 13:	114/214	MODBUS - COMMUNICATION FAILURE TO FLOWMETER	(1=active)	All software versions
Bit 14:	115/215	FLOWMETER PULSE LINE FAILURE	(1=active)	All software versions
Bit 15:	116/216	FLOWMETER FAILURE	(1=active)	All software versions
<b>Register 2:</b>				
Bit 0:	117/217	POWER UP OF CONTROLLER CAUSED BY POWER FAILURE	(1=active)	All software versions
Bit 1:	118/218	VFR MEASURING MODE NOT AVAILABLE	(1=active)	All software versions
Bit 2:	119/219	FLOWMETER MEASURING MODE NOT AVAILABLE	(1=active)	All software versions
Bit 3:	120/220	NO MEASURING MODE AVAILABLE	(1=active)	All software versions
Bit 4:	121/221	AIR INDEX IS ABOVE CRITICAL VALUE	(1=active)	All software versions
Bit 5:	127/227	PRESSURE P1 > HIHI (ACKNOWLEDGEMENT REQUIRED!)	(1=active)	V1.04.00 and higher
Bit 6:	128/228	PRESSURE P2 > HIHI (ACKNOWLEDGEMENT REQUIRED!)	(1=active)	V1.04.00 and higher
Bit 7:	122/222	WARNING: AIR INDEX HIGH, TAKE STEPS FOR REDUCTION OF ENTRAINED AIR	(1=active)	V1.04.00 and higher
Bit 8:	123/223	STANDARD DENSITY OUT OF RANGE (LOW LIMIT)	(1=active)	V1.04.00 and higher
Bit 9:	124/224	STANDARD DENSITY OUT OF RANGE (HIGH LIMIT)	(1=active)	V1.04.00 and higher
Bit 10:	125/225	OBSERVED DENSITY OUT OF RANGE (LOW LIMIT)	(1=active)	V1.04.00 and higher
Bit 11:	126/226	OBSERVED DENSITY OUT OF RANGE (HIGH LIMIT)	(1=active)	V1.04.00 and higher
Bit 12:	129/229	ERROR PRESENT DURING THIS OPERATION	(1=active)	V1.04.00 and higher
Bit 13:	131/231	PROMASS CUSTODY TRANSFER LOGBOOK FULL	(1=active)	V5.01.00 and higher
Bit 14:	132/232	PROMASS STATUS WARNING	(1=active)	V5.01.00 and higher

*Mass Flow*

Modbus register:	Line 1: 30016 Line 2: 30071	Current mass flow in [t/h]
Register count value:	2	



Data type:	Float	
Access:	Read	
SBC600 software version:	All	

*Air Index*

Modbus register:	Line 1: 30018 Line 2: 30073	Air index for current operation
Register count value:	2	
Data type:	Float	
Access:	Read	
SBC600 software version:	All	

*Tube Damping*

Modbus register:	Line 1: 30020 Line 2: 30075	Tube damping of the Promass in [A/m]. If invalid, the value is displayed as <b>-9999</b> .
Register count value:	2	
Data type:	Float	
Access:	Read	
SBC600 software version:	All	

*Temperature T1*

Modbus register:	Line 1: 30022 Line 2: 30077	Temperature T1 in [°C]. If invalid, the value is displayed as <b>-9999</b> .
Register count value:	2	
Data type:	Float	
Access:	Read	
SBC600 software version:	All	

*Pressure P1*

Modbus register:	Line 1: 30024 Line 2: 30079	Pressure P1 in [bar (a)]. If invalid, the value is displayed as <b>-9999</b> .
Register count value:	2	
Data type:	Float	
Access:	Read	
SBC600 software version:	All	

*Pressure P2*

Modbus register:	Line 1: 30026 Line 2: 30081	Pressure P2 in [bar (a)]. If invalid, the value is displayed as <b>-9999</b> .
Register count value:	2	
Data type:	Float	
Access:	Read	
SBC600 software version:	All	

*Flowing Density*

Modbus register:	Line 1: 30028 Line 2: 30083	Flow density of the Promass in [kg/m <sup>3</sup> ]. If invalid, the value is displayed as <b>-9999</b> .
Register count value:	2	
Data type:	Float	
Access:	Read	
SBC600 software version:	All	

*Exciter Current*

Modbus register:	Line 1: 30030 Line 2: 30085	Exciter current of the Promass in [mA]. If invalid, the value is displayed as <b>-9999</b> .
Register count value:	2	
Data type:	Float	
Access:	Read	
SBC600 software version:	All	

*Total Quantity (Off-Loading / Reverse)*

Modbus register:	Line 1: 30032 Line 2: 30087	Total quantity in [t] for the current operation. The value is displayed with 3 decimal places.
Register count value:	10	
Data type:	String (20)	
Access:	Read	
SBC600 software version:	All	

*Total Quantity (Off-Loading / Reverse) [FLOAT]*

Modbus register:	Line 1: 30132 Line 2: 30134	Total quantity in [t] for the current operation.  The accuracy of this value is limited. The number of decimal places displayed depends on the totalizer value. For maximum accuracy, use the string value (register 30032/30087).
Register count value:	2	
Data type:	Float	
Access:	Read	
SBC600 software version:	V1.05.00 and higher	

*Total Volume (Off-Loading / Reverse)*

Modbus register:	Line 1: 30042 Line 2: 30097	Total volume in [m <sup>3</sup> ] for the current operation. The value is displayed with 3 decimal places.
Register count value:	10	
Data type:	String (20)	
Access:	Read	
SBC600 software version:	All	

*Total Volume (Off-Loading / Reverse) at std. t*

Modbus register:	Line 1: 30136 Line 2: 30146	Total volume in [m <sup>3</sup> ] at standard temperature for the current operation. The value is displayed with 3 decimal places.
Register count value:	10	

Data type:	String (20)	
Access:	Read	
SBC600 software version:	V1.06 and higher	

*Date – Time last Reset*

Modbus register:	Line 1: 30052 Line 2: 30107	Date and time at which the operator clicked the <b>Operation Complete</b> or <b>Reset Total</b> button. Format: YYYY/MMM/DD hh:mm:ss
Register count value:	10	
Data type:	String (20)	
Access:	Read	
SBC600 software version:	All	

*Promass Error Status*

Modbus register:	Line 1: 30062 Line 2: 30117	Promass error code. For error codes, see the Promass manual 1 = no error
Register count value:	1	
Data type:	Integer (16-bit signed)	
Access:	Read	
SBC600 software version:	All	

*Control Valve Feedback*

Modbus register:	Line 1: 30063 Line 2: 30118	Feedback from the back-pressure control valve in [%]. If invalid, the value is displayed as <b>-9999</b> .
Register count value:	2	
Data type:	Float	
Access:	Read	
SBC600 software version:	All	

*Batch Number*

Modbus register:	Line 1: 30065 Line 2: 30120	Current batch number.
Register count value:	2	
Data type:	Double integer (32-bit signed)	
Access:	Read	
SBC600 software version:	All	

*Operating Mode*

Modbus register:	Line 1: 30067 Line 2: 30122	Current BMC operating mode (flow direction) <ul style="list-style-type: none"> <li>▪ 1 = REVERSE Direction "Terminal &gt; Vessel"</li> <li>▪ 2 = OFF-LOADING Direction "Vessel &gt; Terminal"</li> </ul>
Register count value:	1	
Data type:	Integer (16-bit signed)	

Access:	Read	
SBC600 software version:	All	

*Batch Mode*

Modbus register:	Line 1: 30068 Line 2: 30123	Current batch mode (mass unit). <ul style="list-style-type: none"> <li>■ 1 = MASS (VACUUM)</li> <li>■ 2 = MASS (IN AIR)</li> </ul>
Register count value:	1	
Data type:	Integer (16-bit signed)	
Access:	Read	
SBC600 software version:	V1.00.00 - V1.05.xx	

*Batch Mode*

Modbus register:	Line 1: 30068 Line 2: 30123	Current batch mode. 4 digits (digit 4   digit 3   digit 2   digit 1) Digit 1: Batch mode <ul style="list-style-type: none"> <li>■ 1 = MASS (VACUUM)</li> <li>■ 2 = MASS (IN AIR)</li> </ul> Digit 2: Std. temp. 0 = V15 Digit 3: Std. density <ul style="list-style-type: none"> <li>■ 0 = Fwavg.</li> <li>■ 1 = Fixed lab</li> <li>■ 2 = Default (lab)</li> </ul> Digit 4: Fluid group <ul style="list-style-type: none"> <li>■ 1 = Crude</li> <li>■ 2 = Gasoline</li> <li>■ 3 = Trans. area</li> <li>■ 4 = Jet group</li> <li>■ 5 = Fuel oil</li> <li>■ 6 to 8 = Free fill 1 to 3</li> </ul>
Register count value:	1	
Data type:	Integer (16-bit signed)	
Access:	Read	
SBC600 software version:	V1.06.00 and higher	

*Operating Status*

Modbus register:	Line 1: 30226 Line 2: 30227	Current operating status. The operating status is defined by the <b>Operation Complete</b> or <b>Reset Total</b> buttons in the <b>Batch Control</b> screen. <ul style="list-style-type: none"> <li>■ 0 = NO OPERATION (<b>Operation Complete</b> button last clicked)</li> <li>■ 1 = OPERATION RUNNING (<b>Reset Total</b> button last clicked)</li> </ul>
Register count value:	1	
Data type:	Integer (16-bit signed)	
Access:	Read	
SBC600 software version:	V1.00.00 - V1.04.02	

*Operating Status*

Modbus register:	Line 1: 30226 Line 2: 30225	Current operating status. The operating status is defined by the <b>Operation Complete</b> or <b>Reset Total</b> buttons in the <b>Batch Control</b> screen. <ul style="list-style-type: none"> <li>■ 0 = NO OPERATION (<b>Operation Complete</b> button last clicked)</li> <li>■ 1 = OPERATION RUNNING (<b>Reset Total</b> button last clicked)</li> </ul>
Register count value:	1	
Data type:	Integer (16-bit signed)	
Access:	Read	
SBC600 software version:	V1.05.00 and higher	

*Standard Density at std. t*

Modbus register:	Line 1: 30227 Line 2: 30231	Standard density for the current operation.
Register count value:	2	
Data type:	Float	
Access:	Read	
SBC600 software version:	V1.04.00 and higher	

*Observed Density*

Modbus register:	Line 1: 30229 Line 2: 30233	Observed density for the current operation.
Register count value:	2	
Data type:	Float	
Access:	Read	
SBC600 software version:	V1.04.00 and higher	

*Fwavg. Standard Density bei Std. T*

Modbus register:	Line 1: 30124 Line 2: 30128	Average flow-weighted standard density for the current operation.
Register count value:	2	
Data type:	Float	
Access:	Read	
SBC600 software version:	V1.05.00 and higher	

*Fwavg. Observed Density*

Modbus register:	Line 1: 30126 Line 2: 30130	Average flow-weighted observed density for the current operation.
Register count value:	2	
Data type:	Float	
Access:	Read	
SBC600 software version:	V1.05.00 and higher	

*Fixed Lab Standard Density*

Modbus register:	Line 1: 30156 Line 2: 30158	Fixed laboratory standard density for the current operation.
Register count value:	2	
Data type:	Float	
Access:	Read	
SBC600 software version:	V1.06.00 and higher	

*Non-resettable Mass Totalizer Off-Loading*

Modbus register:	Line 1: 30160 Line 2: 30170	Non-resettable mass totalizer (off-loading totalizer) in [t] or [t(air)] depending on the configured system settings. The value is displayed with 3 decimal places.
Register count value:	10	

Data type:	String (20)	
Access:	Read	
SBC600 software version:	V5.01.00 and higher	

#### *Non-resettable Mass Totalizer Reverse*

Modbus register:	Line 1: 30180 Line 2: 30190	Non-resettable mass totalizer (reverse totalizer) in [t] or [t(air)] depending on the configured system settings. The value is displayed with 3 decimal places.
Register count value:	10	
Data type:	String (20)	
Access:	Read	
SBC600 software version:	V5.01.00 and higher	

#### *Trigger Time Synchronization*

Modbus register:	40005	Trigger to set the time of the operator terminal (HMI) to the target time. Target time: See register 40006. Bit 0: The rising edge sets the time of the operator terminal to the target time Feedback on successful synchronization of the time is provided via register 30237.  The time and date of the PLC are synchronized to the time and date of the operator terminal once an hour.
Register count value:	1	
Data type:	Integer (16-bit signed)	
Access:	Write	
SBC600 software version:	V5.02.00 and higher	

#### *Target Time for Time Synchronization*

Modbus register:	40006	Enter the target time to which the operator terminal (HMI) is set by a rising edge of bit 0 of register 40005. Enter the time as an integer in the following format: <ul style="list-style-type: none"> <li>▪ Minutes (mm) as a decimal value from 0 to 59 (xxhhmm)</li> <li>▪ Hours (hh) as a decimal value from 1 to 22 (xxhhxx)</li> </ul> Examples: <ul style="list-style-type: none"> <li>▪ 215 (decimal) = 02:15</li> <li>▪ 1612 (decimal) = 16:12</li> </ul>  <ul style="list-style-type: none"> <li>▪ Synchronization is not performed if the target time is entered in an incorrect format.</li> <li>▪ Synchronization is not performed if the deviation is greater than <math>\pm 5</math> minutes. You must correct the time and date via the HMI.</li> <li>▪ Daylight saving time should not be enabled in the PLC and on the HMI.</li> </ul>
Register count value:	1	
Data type:	Integer (16-bit signed)	
Access:	Write	
SBC600 software version:	V5.02.00 and higher	

*Feedback Time Synchronization*

Modbus register:	30237	Feedback if the time synchronization was successful, see register 40005 and 40006. Bit 0: The synchronization of the time was successful if the signal was set to "1" for 5 seconds.
Register count value:	1	
Data type:	Integer (16-bit signed)	
Access:	Read	
SBC600 software version:	V5.02.00 and higher	

*Enable Remote Batch Operation Control*

Modbus register:	Line 1: 30238 Line 2: 30239	Parameter to activate the "Remote Batch Operation Control" function. Bit 0: <b>Operation Complete</b> or <b>Reset Total &amp; Setup Next Batch</b> enabled. See register 40007/40009. The <b>Operation Complete</b> and <b>Reset Total &amp; Setup Next Batch</b> functions are only available via Modbus if the corresponding bit is set to "1".
Register count value:	1	
Data type:	Integer (16-bit signed)	
Access:	Read	
SBC600 software version:	V5.02.00 and higher	

*Remote Batch Operation Control*

Modbus register:	Line 1: 40007 Line 2: 40009	Parameter to control the <b>Batch Operation</b> function remotely. <ul style="list-style-type: none"> <li>▪ Bit 0 (rising edge): Operation Complete</li> <li>▪ Bit 1 (rising edge): Reset Total &amp; Setup Next batch</li> <li>▪ Bit 8: Printing of the off-loading metering ticket for <b>Operation Complete</b> enabled.</li> <li>▪ Bit 9: Printing of the in-transit metering ticket for <b>Reset Total &amp; Setup Next Batch</b> enabled.</li> </ul>
Register count value:	1	
Data type:	Integer (16-bit signed)	
Access:	Write	
SBC600 software version:	V5.02.00 and higher	

*Product Selection*

Modbus register:	Line 1: 40008 Line 2: 40010	Select product number for the <b>Reset Total &amp; Setup Next Batch</b> function. To select the corresponding product, you must enter <b>1 to 8</b> and activate the corresponding product for the line on the SBC600 operator terminal. In all other cases, the product set at the factory is selected.
Register count value:	1	
Data type:	Integer (16-bit signed)	
Access:	Write	
SBC600 software version:	V5.02.00 and higher	

## 15.4 Information on the third-party software used

### 15.4.1 Rockwell Factory Talk View – Site Edition and RSLinx

Copyright (c) 2012 Rockwell Automation, Inc. All Rights Reserved.

#### Limited warranty

The Software is warranted for ninety days after its initial delivery to you. It will substantially conform with its Documentation supplied by Rockwell Automation at the

time of initial delivery of the Software. Defective media will be replaced without charge if returned during the warranty period. This warranty shall be void if you attempt to modify the Software in any way. Rockwell Automation makes no representation or warranty, express or implied, that the operation of the Software will be uninterrupted or error free, or that the functions contained in the Software will meet or satisfy your intended use or requirements. Complete responsibility for decisions made or actions taken based on information obtained using the Software is given over to the user.

To the maximum extent permitted by law the foregoing limited warranty is in lieu of all other warranties, express or implied, and Rockwell Automation disclaims any and all implied warranties or conditions, including (without limitation) any warranty of title, noninfringement of third party rights, merchantability or fitness for a particular purpose or any warranty under UCITA. Some jurisdictions do not allow the exclusion of implied warranties, so the above exclusion may not apply to you. This warranty gives you specific legal rights, and you may also have other rights which vary from jurisdiction to jurisdiction.

#### **Limitation of liability**

To the maximum extent permitted by applicable law, in no event shall Rockwell Automation or its third party licensors be liable for any special, incidental, indirect, punitive, or consequential damages whatsoever (including, but not limited to, damages for loss of profits or confidential or other information, for business interruption, for lost savings, for loss of privacy, and for any other pecuniary or other loss whatsoever) arising out of or in any way related to the use of or inability to use the software, even if Rockwell Automation or its reseller have been advised of the possibility of such damages.

Some jurisdictions do not allow the limitation or exclusion of liability for incidental or consequential damages, so the above limitation may not apply to you. Rockwell Automation's maximum cumulative liability relative to all claims and liabilities, including that with respect to direct damages and obligations under any indemnity, whether or not insured, will not exceed the cost of the software giving rise to the claim or liability. All of these disclaimers and limitations of remedies and/or liability will apply regardless of any other contrary provision of this EULA or any other agreement between you and Rockwell Automation and regardless of the form of action, whether in contract, tort or otherwise, and further will extend to the benefit of Rockwell Automation's vendors, appointed distributors and other authorized resellers as third-party beneficiaries.

You may obtain a copy of the License at: <http://www.rockwellautomation.com/>

### **15.4.2 Microsoft(R) Windows(R) Embedded Standard 7**

Copyright (c) 2010 Microsoft Corporation. All Rights Reserved.

#### **Liability limitations**

You can recover from Microsoft and its affiliates only direct damages up to two hundred fifty U.S. Dollars (U.S. \$250.00). You cannot recover any other damages, including consequential, lost profits, special, indirect or incidental damages.

This limitation applies to:

- anything related to the software, services, content (including code) on third party internet sites, or third party programs, and
- claims for breach of contract, breach of warranty, guarantee or condition, strict liability, negligence, or other tort to the extent permitted by applicable law.

It also applies even if Microsoft should have been aware of the possibility of the damages. The above limitation may not apply to you because your country may not allow the exclusion or limitation of incidental, consequential or other damages.

You may obtain a copy of the License at: [http://www.microsoftstore.com/store/msusa/en\\_US/DisplayHelpEULAPage](http://www.microsoftstore.com/store/msusa/en_US/DisplayHelpEULAPage)



### 15.4.3 MICROSOFT SQL SERVER 2008 R2 EXPRESS

Copyright (c) 2010 Microsoft Corporation. All Rights Reserved.

#### **Disclaimer of warranty**

The software is licensed as-is. You bear the risk of using it. Microsoft gives no express warranties, guarantees or conditions. You may have additional consumer rights under your local laws which this agreement cannot change. To the extent permitted under your local laws, Microsoft excludes the implied warranties of merchantability, fitness for a particular purpose and non-infringement.

#### **Limitation on and exclusion of remedies and damages**

You can recover from Microsoft and its suppliers only direct damages up to U.S. \$5.00. You cannot recover any other damages, including consequential, lost profits, special, indirect or incidental damages.

You may obtain a copy of the License at: [http://www.microsoftstore.com/store/msusa/en\\_US/DisplayHelpEULAPage](http://www.microsoftstore.com/store/msusa/en_US/DisplayHelpEULAPage)

### 15.4.4 Comfort on-screen keyboard

Copyright (c) 2006-2015 Comfort Software Group. All rights reserved.

#### **Limited warranty**

If you follow the instructions, the software will perform substantially as described in the COMFORTSOFTWARE materials that you receive in or with the software.

Term of warranty; warranty recipient; length of any implied warranties. The limited warranty covers the software for one year after acquired by the first user. If you receive supplements, updates, or replacement software during that year, they will be covered for the remainder of the warranty or 30 days, whichever is longer. If the first user transfers the software, the remainder of the warranty will apply to the recipient. To the extent permitted by law, any implied warranties, guarantees or conditions last only during the term of the limited warranty. Some states do not allow limitations on how long an implied warranty lasts, so these limitations may not apply to you. They also might not apply to you because some countries may not allow limitations on how long an implied warranty, guarantee or condition lasts.

#### **Exclusions from warranty**

This warranty does not cover problems caused by your acts (or failures to act), the acts of others, or events beyond COMFORTSOFTWARE's reasonable control.

#### **Remedy for breach of warranty**

COMFORTSOFTWARE will repair or replace the software at no charge. If COMFORTSOFTWARE cannot repair or replace it, COMFORTSOFTWARE will refund the amount shown on your receipt for the software. It will also repair or replace supplements, updates and replacement software at no charge. If COMFORTSOFTWARE cannot repair or replace them, it will refund the amount you paid for them, if any. You must uninstall the software and return any media and other associated materials to COMFORTSOFTWARE with proof of purchase to obtain a refund. These are your only remedies for breach of the limited warranty.

#### **Consumer rights not affected**

You may have additional consumer rights under your local laws, which this agreement cannot change.

**Warranty procedures**

You need proof of purchase for warranty service. For warranty service or information about how to obtain a refund for software, contact COMFORTSOFTWARE at <http://www.comfort-software.com/>.

**No other warranties**

The limited warranty is the only direct warranty from COMFORTSOFTWARE. COMFORTSOFTWARE gives no other express warranties, guarantees or conditions. Where allowed by your local laws, COMFORTSOFTWARE excludes implied warranties of merchantability, fitness for a particular purpose and non-infringement. If your local laws give you any implied warranties, guarantees or conditions, despite this exclusion, your remedies are described in the Remedy for Breach of Warranty clause above, to the extent permitted by your local laws.

**Limitation on and exclusion of damages for breach of warranty**

The Limitation on and Exclusion of Damages clause above applies to breaches of this limited warranty. This warranty gives you specific legal rights, and you may also have other rights which vary from state to state. You may also have other rights which vary from country to country.

You may obtain a copy of the License at: <http://www.comfort-software.com/>





71685354

[www.addresses.endress.com](http://www.addresses.endress.com)

---