

Operating Instructions

Raman Rxn2





Table of Contents





1 About this document.....	4		
1.1 Warnings.....	4		
1.2 Symbols on the device.....	4		
1.3 U.S. export compliance	4		
1.4 List of abbreviations.....	5		
2 Basic safety instructions	7		
2.1 Requirements for the personnel.....	7		
2.2 Intended use.....	7		
2.3 Workplace safety	7		
2.4 Operational safety.....	7		
2.5 Product safety	8		
2.6 IT security	8		
3 Product description	9		
3.1 The Raman Rxn2 analyzer.....	9		
3.2 Raman RunTime software overview.....	10		
3.3 Product design.....	11		
3.4 Probe connectors.....	13		
4 Incoming product acceptance and identification	14		
4.1 Incoming acceptance.....	14		
4.2 Scope of delivery	15		
4.3 Certificates and approvals	15		
5 Installation	16		
5.1 Site requirements.....	16		
5.2 Initial analyzer setup	17		
6 Electrical and I/O connections	24		
		6.1 Overview of rear panel electrical and I/O connections.....	24
7 Commissioning.....	25		
7.1 Connectivity	25		
7.2 Electrical and I/O connections	25		
7.3 Interior of the Raman Rxn2.....	32		
7.4 Raman Rxn2 hardware components.....	33		
8 Operation.....	36		
8.1 Raman RunTime embedded software	36		
8.2 Initial Raman RunTime setup.....	36		
8.3 Calibration and verification.....	37		
9 Diagnostics and troubleshooting.....	39		
9.1 Warnings and errors	39		
9.2 Raman Rxn2 system and power loss.....	41		
10 Maintenance	42		
10.1 Optimization	42		
10.2 Real-time clock backup battery replacement ...	43		
10.3 Servicing the Raman Rxn2 analyzer	46		
11 Repair	49		
11.1 Servicing and spare parts	49		
12 Technical data.....	50		
12.1 Specifications.....	50		
12.2 Certifications.....	51		
13 Supplementary documentation	51		
14 Index.....	53		

1 About this document

1.1 Warnings

Structure of Information	Meaning
 WARNING Causes (/consequences) Consequences of noncompliance (if applicable) ▶ Corrective action	This symbol alerts you to a dangerous situation. Failure to avoid the dangerous situation can result in a fatal or serious injury.
 CAUTION Causes (/consequences) Consequences of noncompliance (if applicable) ▶ Corrective action	This symbol alerts you to a dangerous situation. Failure to avoid this situation can result in minor or more serious injuries.
NOTICE Cause/situation Consequences of noncompliance (if applicable) ▶ Action/note	This symbol alerts you to situations which may result in damage to property.

1.2 Symbols on the device

Symbol	Description
	The Laser Radiation symbol is used to alert the user to the danger of exposure to hazardous visible laser radiation when using the Raman Rxn2 system.
	The High Voltage symbol that alerts people to the presence of electric potential large enough to cause injury or damage. In certain industries, high voltage refers to voltage above a certain threshold. Equipment and conductors that carry high voltage warrant special safety requirements and procedures.
	The CSA Certification Mark indicates that the product was tested against and met the applicable North American standards requirements.
	The WEEE symbol indicates that the product should not be discarded as unsorted waste but must be sent to separate collection facilities for recovery and recycling.
	The CE Marking indicates conformity with health, safety, and environmental protection standards for products sold within the European economic area (EEA).

1.3 U.S. export compliance

The policy of Endress+Hauser is strict compliance with U.S. export control laws as detailed on the website of the [Bureau of Industry and Security](#) at the U.S. Department of Commerce.

1.4 List of abbreviations

Term	Description
AC	alternating current
ALT	alternate
ANSI	American National Standards Institute
ATX	advanced technology extended
ATEX	atmosphere explosible
AWG	American wire gauge
°C	Celsius
CAL	calibration
CDRH	Center for Devices and Radiological Health
CFR	Code of Federal Regulations
cm	centimeter
COLL	collection
CSM	calibration switching module
CSV	comma separated value
DC	direct current
EMC	electromagnetic compatibility
EO	electro-optical
EPL	equipment protection level
EU	European Union
EXC	excitation
°F	Fahrenheit
FC	ferrule connector
GLP	good laboratory practice
GMP	good manufacturing practice
HCA	Raman calibration accessory
Hz	hertz
IEC	International Electrotechnical Commission
INTLK	interlock
IP	internet protocol
IPA	isopropyl alcohol
IR	infrared
IS	intrinsically safe
LED	light emitting diode
LVD	low voltage directive
mm	millimeter
MT	mechanical transfer
mW	milliwatt

Term	Description
NA	numerical aperture
NAT	network address translation
nm	nanometer
OPC	Open Platform Communications
OPC UA	OPC Unified Architecture
PAT	process analytical technology
PCM	power control module
PDF	portable document format
p/n	part number
QbD	quality by design
RTU	remote terminal unit
SPC	spectrum
TCP	transmission control protocol
UPS	uninterruptible power supply
USB	universal serial bus
V	volt
W	watt
WEEE	waste electrical and electronic equipment

2 Basic safety instructions

Read this section carefully to avoid danger to individuals or the facility. Additional laser safety information and hazardous area certification and safety instructions are contained in the *Raman Rxn2 Safety Instructions (XA02700C)*. See *Supplementary documentation* → .

2.1 Requirements for the personnel

- Installation, commissioning, operation, and maintenance of the measuring system may be carried out only by specially trained technical personnel.
- Technical personnel must be authorized by the plant operator to carry out the specified activities.
- Electrical connections may be performed only by an electrical technician.
- Technical personnel must have read and understood these Operating Instructions and must follow the instructions contained herein.
- Faults at the measuring point may only be rectified by authorized trained personnel. Repairs not described in this document must be carried out only directly at the manufacturer's site or by the service organization.

2.2 Intended use

The Raman Rxn2 analyzer is designed for use in chemical composition measurements of solids, liquids, or turbid media in a laboratory or process development environment.

The Raman Rxn2 is particularly suited for use in the following applications:

- Endpoint monitoring of chemical reactions
- Crystallinity monitoring of solid materials
- Critical process parameter monitoring and control in upstream cell culture or fermentation bioprocesses
- Molecular structure and composition of plant-based proteins, dairy solids, and cell-based foods
- Small molecule pharmaceutical polymorph identification and monitoring

Use of the device for any purpose other than that described poses a threat to the safety of people and of the entire measuring system and is not permitted.

2.3 Workplace safety

- Do not use the Raman Rxn2 for anything other than its intended use.
- Do not drape the power cord over counters or on hot surfaces, or in areas where damage to the integrity of the power cord may occur.
- Do not open the enclosure of the Raman Rxn2.
- Do not look directly into the laser beam.
- Do not allow emitted laser light to reflect off mirrored or shiny surfaces in an uncontrolled way.
- Minimize the presence of shiny surfaces in the working area and always use a laser beam block to prevent uncontrolled transmission of the laser light.
- Do not leave unused probes uncapped or unblocked while they are still attached to the analyzer.

2.4 Operational safety

Before commissioning the entire measuring point:

1. Verify that all connections are correct.
2. Ensure that electrical cables and optical fiber connections are not damaged.
3. Do not operate damaged products. Protect them against unintentional operation.
4. Label damaged products as defective.

During operation:

1. If faults cannot be rectified, products must be taken out of service and protected against unintentional operation.
2. Keep the door closed when not carrying out service and maintenance work.

⚠ CAUTION

Activities while the analyzer is in operation introduce risk of exposure to hazardous materials.

- ▶ Follow standard procedures for limiting exposure to chemical or biological materials.
- ▶ Follow workplace policies on personal protective equipment including wearing protective clothing, goggles and gloves and limiting physical access to analyzer location.
- ▶ Clean any spills following the appropriate site policies and cleaning procedures.

⚠ CAUTION

There is risk of injury from the analyzer door stop mechanism.

- ▶ If the enclosure needs to be open, always open the analyzer door fully to ensure the analyzer door stop engages properly.

2.5 Product safety

The product is designed to meet local safety requirements for the intended application, and has been tested accordingly, leaving the factory in a condition in which it is safe to operate. All applicable regulations and international standards have been observed. Devices connected to the analyzer must also comply with the applicable safety standards, and users should follow the probe-specific product safety instructions.

2.6 IT security

Our warranty is valid only if the device is installed and used as described in the Operating Instructions. The device is equipped with security mechanisms to protect it against any inadvertent changes to the settings.

IT security measures, which provide additional protection for the device and associated data transfer, must be implemented by the operators themselves in line with their security standards.

3 Product description

3.1 The Raman Rxn2 analyzer

The Raman Rxn2 analyzer, powered by Kaiser Raman technology, is a for-purpose embedded system with built-in Raman RunTime control software. Raman spectroscopy provides the chemical specificity of mid-infrared (IR) spectroscopy and the sampling simplicity of near-IR spectroscopy. By operating in the visible or near-IR spectral region, Raman spectroscopy allows vibrational spectra to be collected *in situ*, using fiber-coupled probes, without sample purging, and without the use of specialty sampling devices.

There are four possible configurations of the Raman Rxn2 analyzer: single-channel, four-channel, hybrid, and starter. All Raman Rxn2 analyzers employ a unique self-monitoring system to ensure the validity of each analysis. The analyzer is capable of two-point self-calibration in extreme environments and utilizes self-diagnostics and spectral correction methods when system calibration is unnecessary. The analyzer's precision is essential for robust chemometric analyses and calibration transfer between instruments. The Raman Rxn2 suite of analyzers allows for remote fiber-optic connections to probe sampling points for installation flexibility. And all configurations of the Raman Rxn2 analyzer are designed for use with the Endress+Hauser line of Raman fiber-optic probes and optics. An ergonomic mobile cart, including built-in probe and optic storage, is available as an option for all Raman Rxn2 configurations.

3.1.1 The Raman Rxn2 single-channel and four-channel configurations

The Raman Rxn2 single-channel configuration offers one fiber-optic sampling probe connector for the accurate measurement, collection, monitoring, and analysis of a single sample. The Raman Rxn2 four-channel configuration provides four fiber-optic sampling probe connectors. Raman Rxn2 single-channel or four-channel configurations are available with a 532 nm, 785 nm, or 993 nm excitation wavelength laser.

Both the Raman Rxn2 single-channel and four-channel configurations are designed for use in an analytical or process development laboratory for routine sample measurements, quality assurance, or process development applications in life sciences, chemical, and food and beverage industries. The four-channel Raman Rxn2 was designed for customers who need to support process development activities so that they can monitor multiple vessels. The ability to follow several different reactions at the same time can quickly build process knowledge and simplify technology transfer from a laboratory into a process environment.

With the Raman RunTime software embedded into the analyzer, the Raman Rxn2 single-channel and four-channel analyzers meet the needs of both good laboratory practice (GLP) and good manufacturing practice (GMP) governed areas within the pharmaceutical industry for process analytical technology (PAT) and quality by design (QbD) applications.

3.1.2 The Raman Rxn2 hybrid configuration

The Raman Rxn2 hybrid configuration is unique because it contains connectors for an Rxn-20 large volumetric probe and a second, alternate (ALT) backscattered probe. The Raman Rxn2 hybrid configuration is only available with a 785 nm excitation wavelength laser.

The two different probe types enable a variety of applications for solids, liquids, and turbid media. A backscattered immersion probe is the preferred approach for measuring liquids because of its short focus, optical window, and bubble-shedding design. The Rxn-20 probe is optimized for large volumetric measurements, enabling focus-free, non-contact representative measurements of solids or turbid media. The hybrid configuration provides maximal sampling flexibility for laboratory, quality control, and process development purposes.

With the Raman RunTime software embedded into the analyzer, the Raman Rxn2 hybrid configuration meets the needs of both good laboratory practice (GLP) and good manufacturing practice (GMP) governed areas within the pharmaceutical industry for process analytical technology (PAT) and quality by design (QbD) applications.

3.1.3 The Raman Rxn2 starter configuration

The standard Raman Rxn2 starter configuration is the analyzer with a single Rxn-10 Raman spectroscopic probe. There is an optional upgrade to configure the analyzer with up to four channels, and the analyzer is compatible with the full range of Endress+Hauser liquid or bioprocessing probes. The Raman Rxn2 starter configuration is only available with a 785 nm excitation wavelength.

The Raman Rxn2 starter configuration is designed for cart-portable or benchtop uses such as material quality, reaction monitoring, basic science research, quality assurance, and unknowns identification. The variety of non-contact or immersion optics compatible with the Rxn-10 probe provides sampling flexibility to support a variety of applications.

3.2 Raman RunTime software overview

Raman RunTime embedded software is the control platform for the suite of Raman Rxn analyzers. Raman RunTime software is intended for easy integration with standard multivariate analysis and automation platforms to enable a real-time, *in situ* process monitoring and control solution. Raman RunTime presents an OPC and Modbus interface, which provides clients with analyzer data as well as analyzer control functions. Raman RunTime is fully embedded into Raman Rxn analyzers. Refer to the *Raman RunTime Operating Instructions (BA02180C)* for descriptions of analyzer operations including analyzer operation, calibration, data models, and error reports.

3.3 Product design

3.3.1 Front panel

On the front panel of the instrument are the standard user interfaces. These include the main **ON/OFF** power switch, the laser **ON/OFF** key switch, light emitting diode (LED) indicators, and a universal serial bus (USB) 3.0 port.

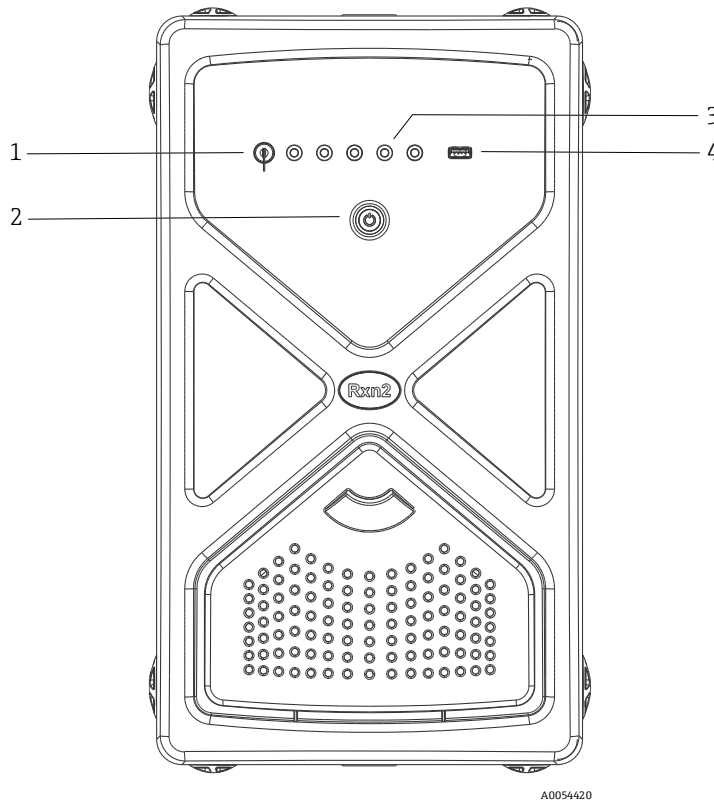

Figure 1: Front panel of a Raman Rxn2 four-channel analyzer

#	Name	Description
1	Laser key switch	The laser key switch turns the laser on and off. The Red LED indicator adjacent to the laser key switch indicates the laser power status. To activate turn the key to the ON position.
2	Main power switch	The main power switch turns the instrument on and off, which includes the laser regardless of the position of the laser key switch. The Power push button incorporates a Blue LED in the shape of a power symbol, which indicates the system power status. The Power push button will communicate error conditions using blink codes when embedded software is not able to communicate them. To turn the instrument on, press and release the Power button once. To turn a responsive instrument off, shut down using Raman RunTime. If the instrument is unresponsive, it may be powered down using a long 10 second press and hold of the Power button.
3	Probe connection status indicators	The bank of Yellow LED indicators between the laser key and USB 3.0 port indicates the physical connection status of the probes. While the Raman Rxn2 four-channel configuration front panel has four LED indicators, the front panel of the Raman Rxn2 hybrid configuration has only two LED indicators, and the front panel of the Raman Rxn2 single-channel configuration has only one LED indicator.
4	USB 3.0 port	The USB 3.0 port is intended to obtain diagnostic exports from the instrument using a USB flash drive.

3.3.2 Rear panel

On the rear panel of the instrument are standard input/output (I/O) ports. These include touchscreen, USB, Ethernet, serial, and video ports.

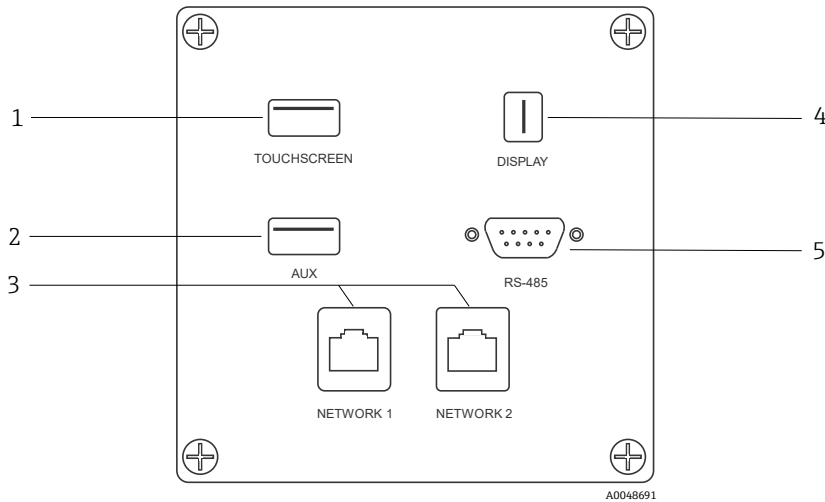

Figure 2: Rear external circuit input/output panel of a Raman Rxn embedded analyzer

#	Name	Description
1	Touchscreen USB port	USB 2.0 port used to connect to the touchscreen.
2	USB port (auxiliary)	USB 2.0 backup port. Reserved for future use.
3	Ethernet port (2)	Ethernet ports for the network connection.
4	Touchscreen video port	Touchscreen video port for connection to local touchscreen display (if needed).
5	RS-485 serial port	RS-485 serial port, half-duplex. Provides automation data via Modbus remote terminal unit (RTU). Port settings configurable in Raman RunTime.

3.3.3 Rear panel: Rxn2 single-channel and four-channel configurations

All normal system input/output (I/O) is located at the rear of the base unit. This includes:

- EO fiber connector/electrical connections for up to four remotely installed probes for the four-channel Raman Rxn2 analyzer (single-channel analyzers have only one probe connection). The electrical connection contained within the fiber optics is an intrinsically safe interlock loop which will turn off the laser in case of fiber breakage.
- Four remote interlock connections for the four-channel Raman Rxn2 analyzer (only one for the single-channel configuration), each intrinsically safe and in series with the fiber breakage detection loops described in previous bullet.
- Two TCP/IP Ethernet ports for OPC and Modbus automation as well as remote control
- One serial RS-485 port for Modbus automation.
- One mini-DisplayPort for local display (if needed)
- Two USB 2.0 Type A ports, one for local touchscreen (if needed) and one reserved for future use
- AC power inlet, C13 plug required. See *Specifications* →

NOTICE

Handle probes and cables with care.

- ▶ Fiber cables should NOT be kinked and should be routed to maintain the minimum bend radius of 152.4 mm (6 in).
- ▶ Permanent damage to the cables may result if they are bent beyond the minimum radius.

3.3.4 Rear panel: Rxn2 hybrid configuration

All normal system I/O is located at the rear of Raman Rxn hybrid analyzers. This includes:

- Fiber-optic connectors/electrical connection for one remotely installed Rxn-20 probe. The electrical connection contained within the fiber optics is an intrinsically safe interlock loop which will turn off the laser for the Rxn-20 probe in case of fiber breakage. All connections are protected by a cover secured to the rear panel with two socket head cap screws.
- EO fiber connector/electrical connection for one remotely installed ALT probe. The electrical connection contained within the fiber optics is an intrinsically safe interlock loop which will turn off the laser for the alternate probe in case of fiber breakage.
- Two remote interlock connections for the Rxn-20 and ALT probes, each intrinsically safe and in series with the fiber breakage detection loops described in previous bullets.
- Two TCP/IP Ethernet ports for OPC and Modbus automation as well as remote control
- One serial RS-485 port for Modbus automation
- One mini DisplayPort for local display, if needed
- Two USB 2.0 Type A ports, one for local touchscreen (if needed) and one reserved for future use
- AC power inlet, C13 plug required. See *Specifications* → .

NOTICE

Handle probes and cables with care.

- ▶ Fiber cables should NOT be kinked and should be routed to maintain the minimum bend radius of 152.4 mm (6 in).
- ▶ Permanent damage to the cables may result if they are bent beyond the minimum radius.

3.4 Probe connectors

The probes are connected to the base unit at the connection panel located on the rear of the base unit.

For single-channel or four-channel Raman Rxn2 configurations, as well as the alternate (ALT) probe channel of the Raman Rxn2 hybrid configuration, each channel employs a single robust electro-optical (EO) connector which contains excitation and collection fiber optics as well as an electrical laser interlock loop. The interlock contained within the probe fiber optics is a low voltage and current loop designed to detect fiber cable breakage and will turn laser emission off for that channel in the event of a break. Ensure the latch is engaged after inserting EO fiber connector.

For the Rxn-20 channel of the Raman Rxn2 hybrid instrument, the main fiber-optic bundle is furcated into three FC fiber-optic connectors and one electrical interlock loop connector. The FC fiber-optic connections are used for laser excitation, Raman scatter collection, and auto-calibration. The interlock loop contained within the probe fiber optic is a low voltage and current loop designed to detect fiber cable breakage and will turn laser emission off for the Rxn-20 probe in the event of breakage.

4 Incoming product acceptance and identification

4.1 Incoming acceptance

1. Verify that the packaging is undamaged. Notify the supplier of any damage to the packaging. Keep the damaged packaging until the issue has been resolved.
2. Verify that the contents are undamaged. Notify the supplier of any damage to the delivery contents. Keep the damaged goods until the issue has been resolved.
3. Check that the delivery is complete and nothing is missing. Compare the shipping documents with your order.
4. Pack the product for storage and transportation in such a way that it is protected against impact and moisture. The original packaging offers the best protection. Make sure to comply with the permitted ambient conditions.

If you have any questions, refer to our website (<https://endress.com/contact>) for the list of local sales channels in your area.

NOTICE

Incorrect transportation can damage the analyzer.

- ▶ Always use a lifting truck or a forklift to transport the analyzer.

4.1.1 Nameplate

The nameplate located on the rear of the analyzer provides the following information about your device:

- Manufacturer contact information
- Laser radiation notice
- Electric shock notice
- Model number
- Serial number
- Wavelength
- Maximum power
- Build month
- Build year
- Patent information
- Certification information

Compare the information on the nameplate with the order.

4.1.2 Identifying the product

The order code and serial number of your product can be found in the following locations:

- On the nameplate
- In the delivery papers

4.1.3 Manufacturer address

Endress+Hauser
371 Parkland Plaza
Ann Arbor, MI 48103 USA

4.2 Scope of delivery

The scope of delivery comprises:

- Raman Rxn2 analyzer in the configuration ordered
- *Raman Rxn2 Operating Instructions*
- *Raman RunTime Operating Instructions*
- Raman Rxn2 Certificate of Product Performance
- Local declarations of conformity, if applicable
- Certificates for hazardous zone use, if applicable
- Raman Rxn2 optional accessories, if applicable

If you have any questions regarding the items delivered, or if anything appears to be missing, refer to our website (<https://endress.com/contact>) for the list of local sales channels in your area.

4.3 Certificates and approvals

The Raman Rxn family of base analyzer units are CE-marked as being compliant with the laser performance requirements of [U.S. 21 CFR, Chapter I, Subchapter \(J\)](#), the low-voltage directive (LVD), the electromagnetic compatibility (EMC) directive, and the applicable laser eye and skin safety standards as indicated below.

- 21 CFR 1040
- LVD 2014/35/EU
- EMC Directive 2014/30/EU
- IEC 60825-1

The Raman Rxn2 base unit has been certified for installation in a nonhazardous area with output into explosive atmospheres under various standards.

The Raman Rxn2 must be installed following all federal, state, and local codes required for the region of installation. Many regions around the world require specific certificates of type review such as IECEx or ATEX before they can be used in the region. See *Certifications* →  to view specific certification approvals for the Raman Rxn2.

5 Installation

5.1 Site requirements

The base unit enclosure contains all functional components of the analyzer. The enclosure is designed for orientation in either the vertical tower position or the horizontal desktop position. The air flow through the base unit draws air in from the front of the unit and exhausts at the rear of the unit. To limit inlet air obstruction, at least 152.4 mm (6 in) of clearance must be maintained at the front of the unit. To limit exhaust air obstruction, the rear of the base unit must have 152.4 mm (6 in) of clearance to the nearest obstruction.

5.1.1 Electrical power

The supply voltage should be regulated and free of voltage spikes. It is recommended, but not required, that an uninterruptible power supply (UPS) is used with the analyzer to prevent potential data loss due to instrument power cycling in response to mains power loss. A UPS capable of providing the analyzer's maximum power consumption, but at least the typical running power of the Raman Rxn2 is highly recommended. See the technical data for the *Base unit* →  for details on power consumption.

For a Raman Rxn2 analyzer, the location selected must have 4 voltage power outlets, 1 for each of the following:

- Base unit
- Touchscreen monitor
- Optional power meter or the Raman calibration accessory (HCA)

Alternatively, these components may be plugged into a power strip on 1 outlet.

5.1.2 Location

The Raman Rxn2 analyzer can be located on a level surface such as a laboratory benchtop or an equipment cart. In addition, the location selected should be:

- Free of moisture, dust, and corrosive vapors
- Isolated from excess vibrations
- Protected from direct sunlight

5.1.3 Ventilation

The location selected should allow for adequate ventilation to both the front and rear of the base unit. A minimum space of 152.4 mm (6 in) must be provided in both the front and rear of the base unit for proper inlet and outlet air movement.

5.1.4 Temperature

The Raman Rxn2 base unit and touchscreen monitor are designed to operate within a temperature range of 15 to 30 °C (59 to 86 °F). In any installation case, care must be taken to keep the instrument inlet air and surrounding air within this temperature range.

5.1.5 Relative humidity

The Raman Rxn2 base unit and touchscreen monitor are designed to operate within an ambient relative humidity range of 20 to 80 %, non-condensing.

5.2 Initial analyzer setup

5.2.1 Installation of Raman Rxn2 analyzer

In some cases, Endress+Hauser requires that installation and initial analyzer setup is performed by trained service personnel from Endress+Hauser or its affiliated channel partners. This section provides only a basic overview of the analyzer setup process and does not facilitate a full onsite installation or IQ/OQ. For IQ/OQ, a trained representative from Endress+Hauser or one of its authorized representatives must be present for both initial inspection and installation of the Raman Rxn2 analyzer. Before the installation, refer to *Site requirements* →  to prepare the site.

5.2.2 Connecting the touchscreen monitor

Connect a touchscreen monitor to the **Display** and **Touchscreen USB** ports on the back of the instrument.

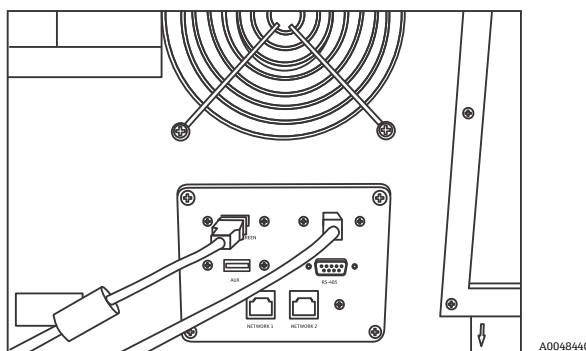

Figure 3: Touchscreen display connections

5.2.3 Connecting a probe

5.2.3.1 For single-channel, four-channel, and starter configurations

Raman Rxn2 single-channel, four-channel, starter, and hybrid (ALT channel only) configurations utilize a unique fiber-optic connector with integrated electrical laser interlock loop. The EO fiber connector on the Raman Rxn2 analyzer is referred to as the 'device-side' connector. The EO fiber connector on the probe fiber cable is referred to as the 'cable-side' connector. The instrument device-side connector uses an integrated spring-loaded cap that will protect the internal fibers from contamination.

1. Remove cover from probe fiber cable-side connector.

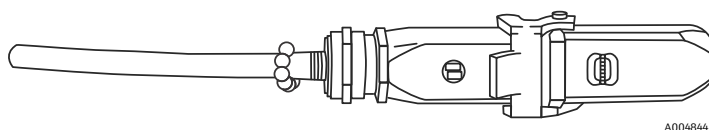
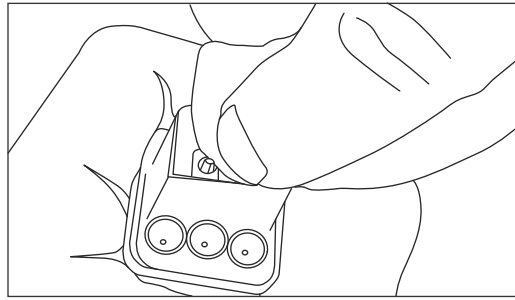

Figure 4: Electro-optical fiber connection with cover

2. Clean fiber tips of cable-side connector prior to installation if cleanliness of fiber tips is unknown.
 - First use a lens wipe very lightly saturated with a solvent, such as reagent grade acetone or 100 % isopropyl alcohol (IPA) followed by a final clean with a 1.25 mm fiber cleaning tool. Do not use the same wipe for both fiber tips.
 - Swipe the fiber tip once with the damp portion of the wipe, then swipe once more with a dry portion of the same wipe. Repeat for both fiber tips.



A0048442

Figure 5: Cleaning electro-optical fiber connection

3. Next, use an IBC 1.25 mm ferrule cleaner with the bulkhead adapter attached to do a final clean of the center of the ferrule where the fiber resides. Press together until a click is heard and repeat once.

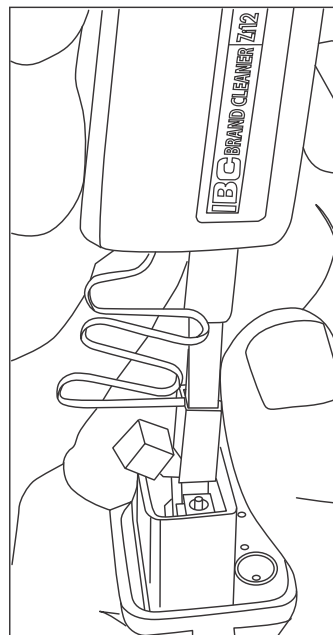

A0048443

Figure 6: Final clean of electro-optical fiber connector fiber tips

4. Release the latch and open the spring-loaded cap on the Raman Rxn2 analyzer device-side connector. Insert the cable-side connector into the instrument device-side connector fully and engage latch to secure. The connectors are polarized and can only be inserted one way. The slotted head screws on the face of both connectors should be facing out.

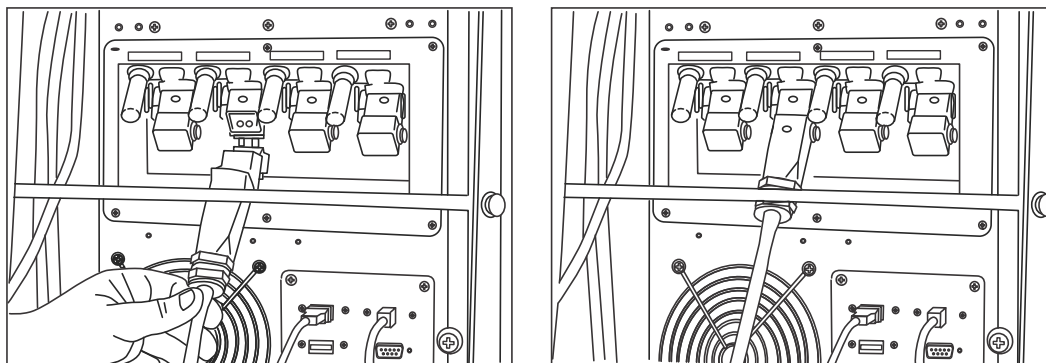

A0048444

Figure 7: Connecting an electro-optical fiber cable to a Raman Rxn2 four-channel analyzer

5. Repeat for each probe.

CAUTION

- ▶ Unused probes that are attached to the Raman Rxn2 analyzer should ALWAYS be capped to prevent stray ambient light from entering the probe. Stray ambient light, whether from an uncapped probe or through incomplete light shielding of the sample, may produce undesirable spectral interferences and result in calibration failure or inaccuracy.

WARNING

- ▶ Probes attached to the Raman Rxn2 analyzer should always be capped or pointed away from people toward a diffuse target if not installed in a sample chamber.
6. For each EO fiber cable, restrain the probe EO fiber-optic cable using the strain relief bar located at the rear of the instrument. For Rxn-20 probe, use the fiber guide and strain relief bar at the rear of the instrument.

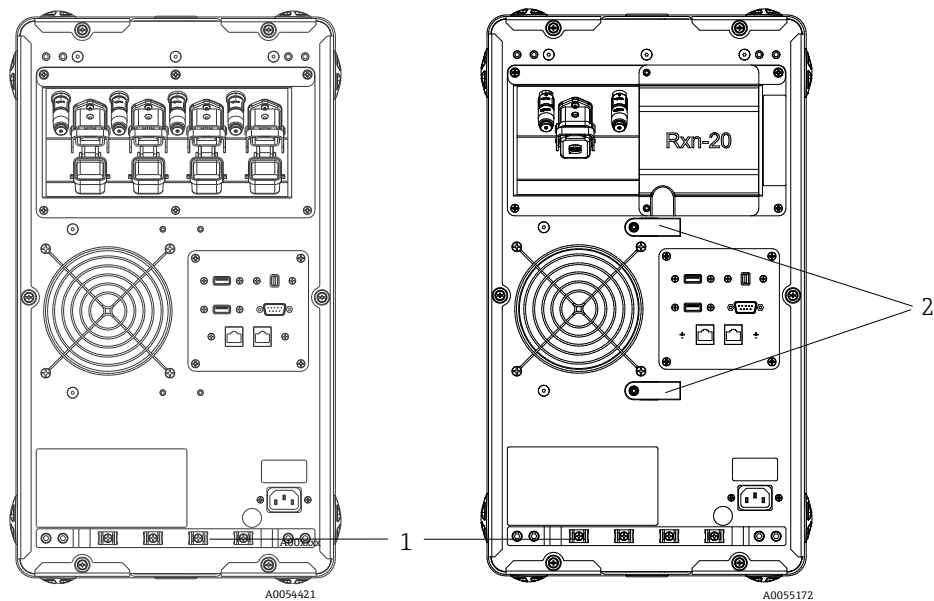

Figure 8: EO fiber strain relief bar on Raman Rxn2 multichannel (left) and Raman Rxn2 hybrid (right)

#	Description
1	Strain relief bar
2	Fiber guide

CAUTION

- ▶ When installing the probe *in situ*, the user must provide strain relief to the EO fiber-optic cable at the probe installation location.

5.2.3.2 For hybrid configurations

The ALT channel utilizes an EO cable with an integrated electrical laser interlock loop, and the process of connecting the ALT channel is described in the previous section. The Rxn-20 channel of the Raman Rxn2 hybrid configuration has four connections points: fiber electrical interlock, excitation, collection, and calibration. The excitation and calibration connections utilize FC style fiber connectors, while the collection connection utilizes a mechanical transfer (MT) style fiber connector. A remote interlock connector is also provided for the Rxn-20 channel and is located adjacent to the fiber electrical interlock connection. The Rxn-20 excitation, collection, and calibration fibers are fragile, and care must be taken to properly route and restrain the fibers using the following procedures.

To connect a probe to the Rxn-20 channel:

1. Remove the Rxn Rxn-20 plastic cover by unscrewing the two socket head cap screws using the 7/64" ball driver included with the instrument. This will reveal the individual connectors for the Rxn-20 channel.

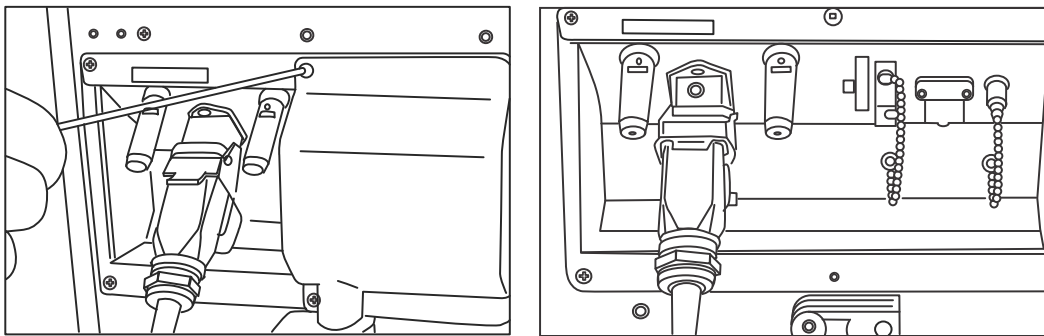

A0048445

Figure 9: Rxn-20 channel cover on rear of Raman Rxn2 hybrid configuration (left) and connectors for Rxn-20 channel (right)

2. On the cable-side connectors, clean **ONLY** the excitation and calibration fiber tips prior to installation if cleanliness of these fiber tips is unknown.
 - First use a lens wipe very lightly saturated with a solvent, such as reagent grade acetone or 100 % IPA followed by a final clean with a 2.5 mm fiber cleaning tool. Do not use the same wipe for both fiber tips.
 - Swipe the fiber tip once with the damp portion of the wipe, then swipe once more with a dry portion of the same wipe. Repeat for both fiber tips.
3. Employ the two strain reliefs on the rear of Raman Rxn2 hybrid configuration (using the 7/64" ball driver) to secure the fiber cable assembly.

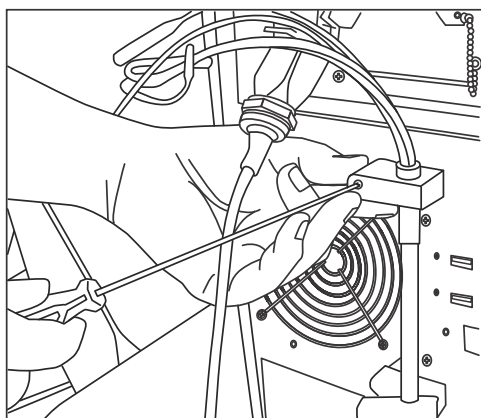

A0048446

Figure 10: Employing strain reliefs to secure the fiber assembly for the Rxn-20 channel

4. Remove the threaded cap from the calibration (CAL) port.
5. Connect the clean calibration fiber to the CAL port, aligning the key on the fiber connector with the notch on the CAL port connector. The fiber should be routed in a helical pattern as shown below to avoid kinks.

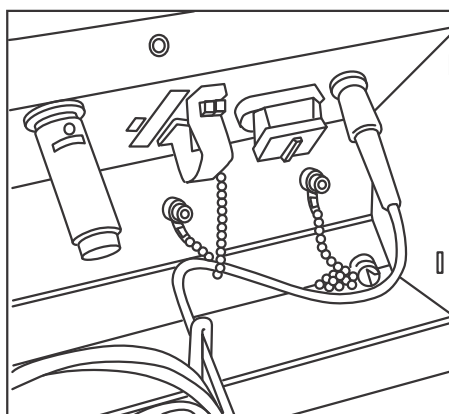

A0048453

Figure 11: Proper connection and routing of the calibration fiber

- Remove the rubber cap from the MT style collection fiber connector. Lift and hold the cover of the collection (COLL) port as the fiber is connected. Align the white dot on the MT style fiber connector with the white mark on the COLL port and insert the fiber connector until it clicks into place. The fiber should be routed in a helical pattern as shown below to avoid kinks.

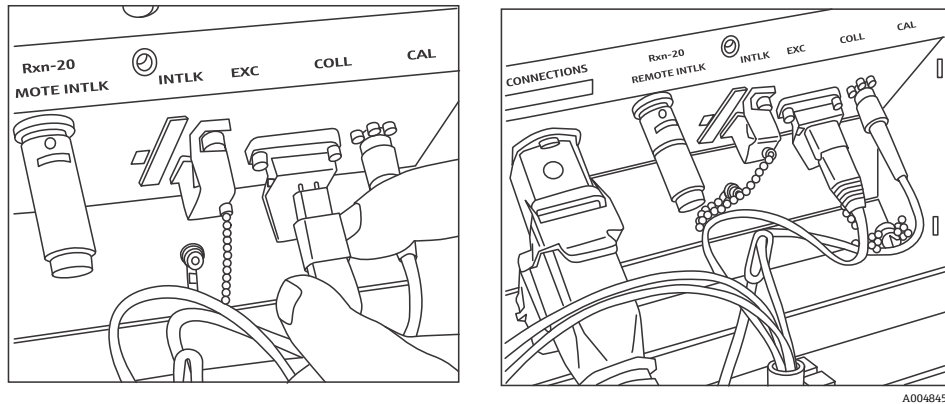

Figure 12: Proper connection and routing of the collection fiber

- Remove the excitation fiber clamp by loosening the clamp screw with a 3/32" ball driver (provided with analyzer) and sliding it out of the way.
- Remove the threaded cap from the excitation (EXC) port.

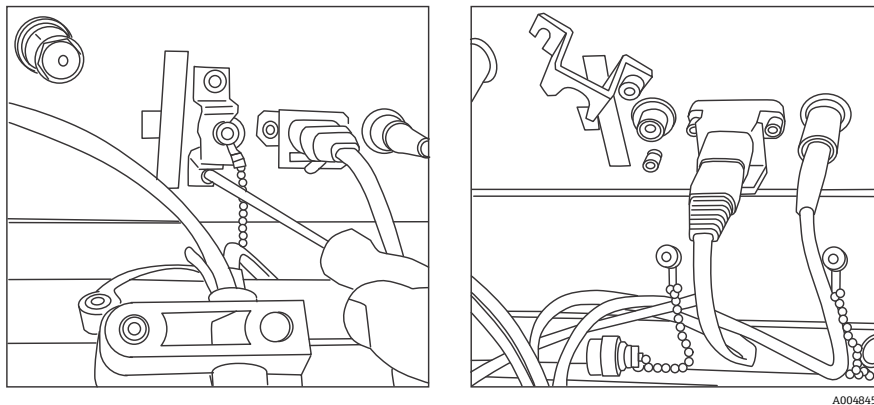

Figure 13: Proper removal of the excitation fiber clamp and threaded cap from the excitation port

- Connect the clean excitation fiber to the EXC port on the connection panel, aligning the key on the fiber connector with the notch on the EXC port connector. The fiber should be routed in a helical pattern to avoid kinks.

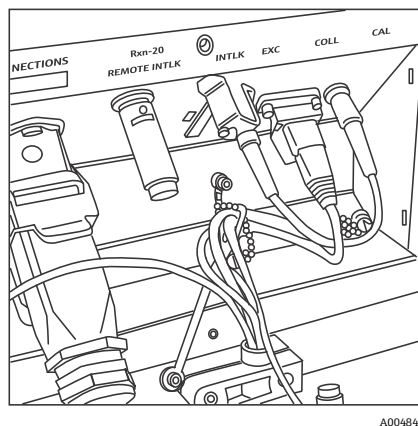

Figure 14: Proper connection and routing of the excitation fiber

- Re-install the excitation fiber safety clamp using a 3/32" ball driver.
- Connect the fiber electrical interlock connector to the interlock (INTLK) port. Route cable behind fiber connections.

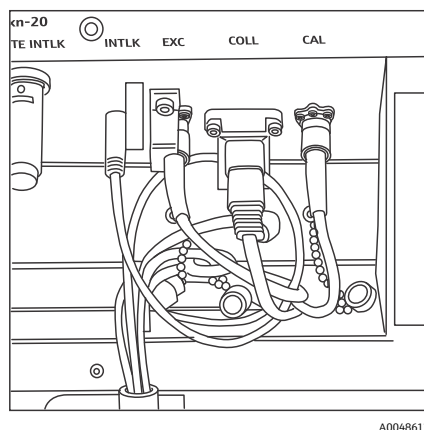

Figure 15: Proper connection of interlock connector and fiber routing

12. Replace the Rxn-20 plastic cover, ensuring that no fibers are caught between the cover and connection panel flange. Replace and tighten the two socket head cap screws to hold cover in place using a 7/64" ball driver.

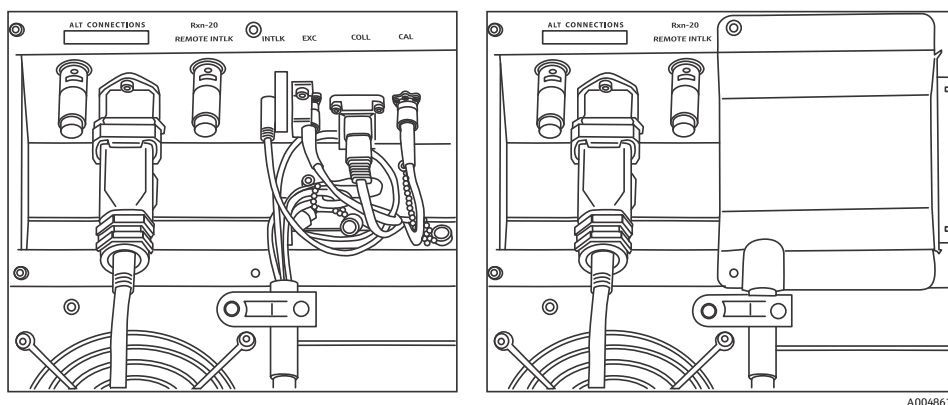

Figure 16: Before (left) and after (right) reattaching the Rxn-20 channel cover

CAUTION

- ▶ Unused probes that are attached to the Raman Rxn2 analyzer should ALWAYS be capped to prevent stray ambient light from entering the probe. Stray ambient light, whether from an uncapped probe or through incomplete light shielding of the sample, may produce undesirable spectral interferences and result in calibration failure or inaccuracy.

WARNING

- ▶ The beam emerging from the Rxn-20 probe is hazardous to the eye. Always secure the probe so that it is pointing safely away from any personnel. Never handle the probe freely when it is operational.

5.2.4 Turning on the Raman Rxn2 analyzer

Press and release the **Power** button and turn the laser key switch to the **ON** position. The **Power** button blinks once per second until Raman RunTime launches. The Laser Enable LED illuminates **Red** and the power switch illuminates a solid **Blue**.

See *Front panel* → for more information about the **Power** button.

5.2.5 Turning off the Raman Rxn2 analyzer

Turning off the analyzer

There are two ways to properly turn off the Raman Rxn2 analyzer. One of these two methods should always be used to turn off the analyzer unless it is unresponsive:

- **Turning off the analyzer: method one.** In Raman RunTime, navigate to **Options > System > General** and click **Shut Down**. The analyzer turns off after about 5 seconds.
- **Turning off the analyzer: method two (hardware option).** Click and hold the **Push** button power switch until it starts to blink (2 seconds). Release the **Push** button. The analyzer turns off after about 5 seconds.

Performing a hard shutdown

To perform a hard shutdown, there are two methods that can be used. Both hard shutdown options involve analyzer hardware and are not options selected from Raman RunTime. They should only be used if Raman RunTime is unresponsive:

- **Performing a hard shutdown: method one.** Click and hold the **Push** button power switch for at least 12 seconds until the analyzer powers down. Then release the **Push** button. After 2 seconds, the power switch begins to blink; ignore and continue to hold down the **Power** button until analyzer powers down. Release the button.
- **Performing a hard shutdown: method two.** Unplug the analyzer.

See the *Raman RunTime Operating Instructions (BA02180C)* for more information.

6 Electrical and I/O connections

6.1 Overview of rear panel electrical and I/O connections

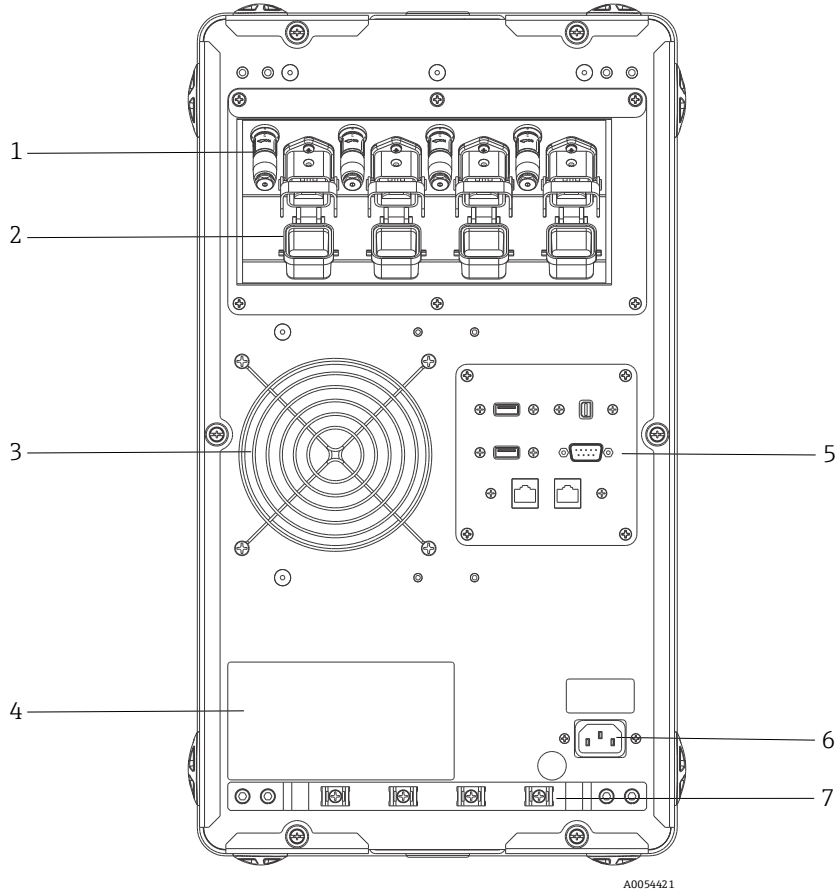

Figure 17: Rear panel of Raman Rxn2 four-channel analyzer

#	Name	Description
1	Remote interlock connectors	Safety feature. To interrupt the laser, remove the black plug.
2	EO fiber connector	Provides fiber-optic laser radiation output, fiber-optic Raman collection and electrical laser interlock loop for each instrument channel. The electrical laser interlock loop is intrinsically safe and is governed by Endress+Hauser drawing 4002396. Match 3 prongs on probe to 3 plugs on EO. Pull latch down to secure probe in place. Laser radiation may NOT exit a channel whose EO fiber connector is removed because removing the EO connector also interrupts the laser interlock loop for that channel.
3	Air exhaust	Air exhaust fan and outlet.
4	CDRH product label	Product information about the Raman Rxn2 analyzer.
5	Analyzer ports	Touchscreen USB port, USB port, Ethernet ports, RS-485 serial port, and touchscreen video port.
6	AC inlet AC 100 to 240 V 50/60 Hz	Power socket outlet that provides AC power to the base unit. Ground pin on this connector serves as the protective conductor terminal.
7	Strain relief	EO fiber cable strain relief mounting location.

7 Commissioning

7.1 Connectivity

Raman RunTime provides network-connected clients with analyzer data as well as analyzer control functions. Raman RunTime supports Modbus and OPC connectivity. OPC UA is the recommended protocol because it allows transfer of large data (full spectral data and diagnostics) and is a more reliable connection than OPC Classic. However, legacy support for OPC Classic (DCOM, also called OPC DA) clients is also built in.

The Raman Rxn2 system must be connected to a network for OPC functionality. Network settings can be viewed and configured in **Options > System > Network**.

7.2 Electrical and I/O connections

An I/O panel is located at the center of the rear panel, which provides several extra low-voltage, non-intrinsically safe external circuits:

- **Touchscreen.** Type A USB 2.0 for connection to a local touchscreen display. This is not required for the instrument to operate as all operation parameters may be set through the instrument's automation interfaces. A touchscreen kit, which includes the interface cable for this connection, is available for purchase from Endress+Hauser under p/n 70187807.
- **Display.** Mini DisplayPort for video connection to a local touchscreen display. This is not required for the instrument to operate as all operation parameters may be set through the instrument's automation interfaces. This port does NOT support DP++; therefore, an active adapter is needed if connecting to a display without native DisplayPort. A touchscreen kit, which includes the interface cable for this connection, is available for purchase from Endress+Hauser under p/n 70187807.
- **Aux.** Type A USB 2.0 reserved for future use.
- **RS-485.** DB9 which provides a half-duplex serial RS-485, two-wire plus ground, Modbus RTU automation interface. Pin 2 is Data+, Pin 3 is Data-, Pin 5 is ground. All other pins are inactive.

Recommended wiring is commercially available shielded, 2 twisted pair, 22 American wire gauge (AWG), terminated with a DB9 receptacle and back shell kit. Endress+Hauser recommends Carol C1352A cable, TE Connectivity 5-747905-2 receptacle and 1991253-9 back shell kit. Cable and connector/back shell of equivalent specifications may be substituted. One pair is used for Data+ and Data- and one of the wires from the second pair is used for ground. It is not recommended to use the shield as a signal ground. No provision for connecting the shield drain is provided at the Raman Rxn2. The shield may be connected to earth at the device on the opposite end of the cable attached to the Raman Rxn2.

- **Network 1.** 10/100/1000 RJ45 Ethernet interface. Provides remote control option and automation data via OPC UA, OPC Classic and Modbus TCP. Use standard Ethernet cabling.
- **Network 2.** Same as Network 1. Both interfaces may be used at the same time.

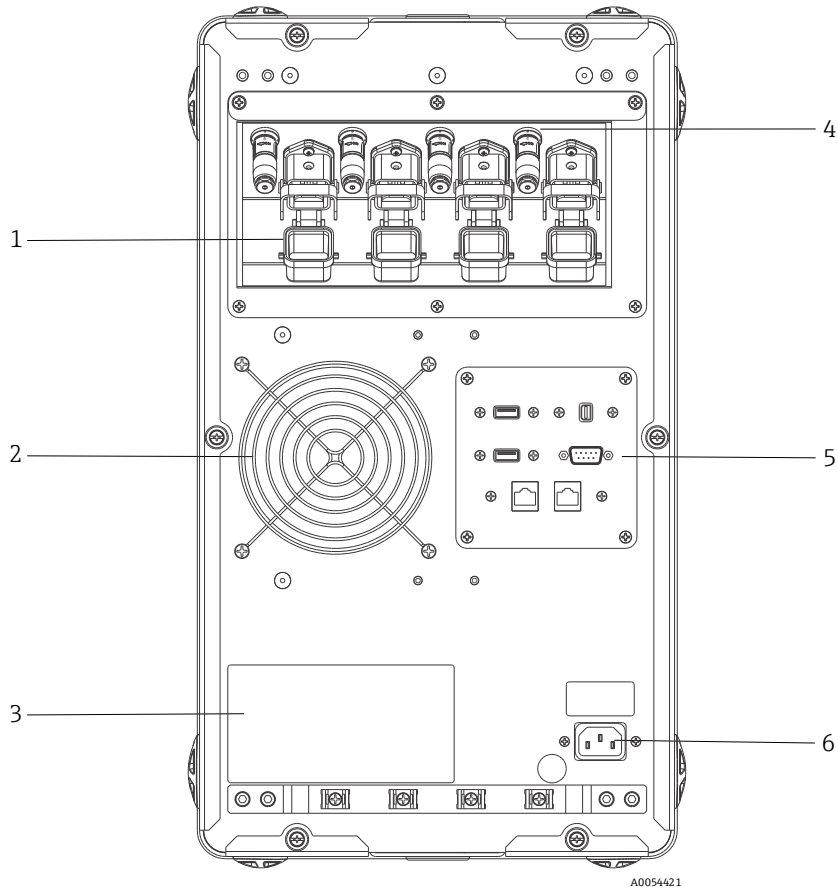

Figure 18: Rear panel on a Raman Rxn2 four-channel analyzer

#	Description
1	Electro-optical (EO) fiber connection
2	Air exhaust
3	CDRH certification label
4	Remote interlock connector
5	External circuit I/O panel
6	AC inlet: AC 100 to 240 V, 50/60 Hz

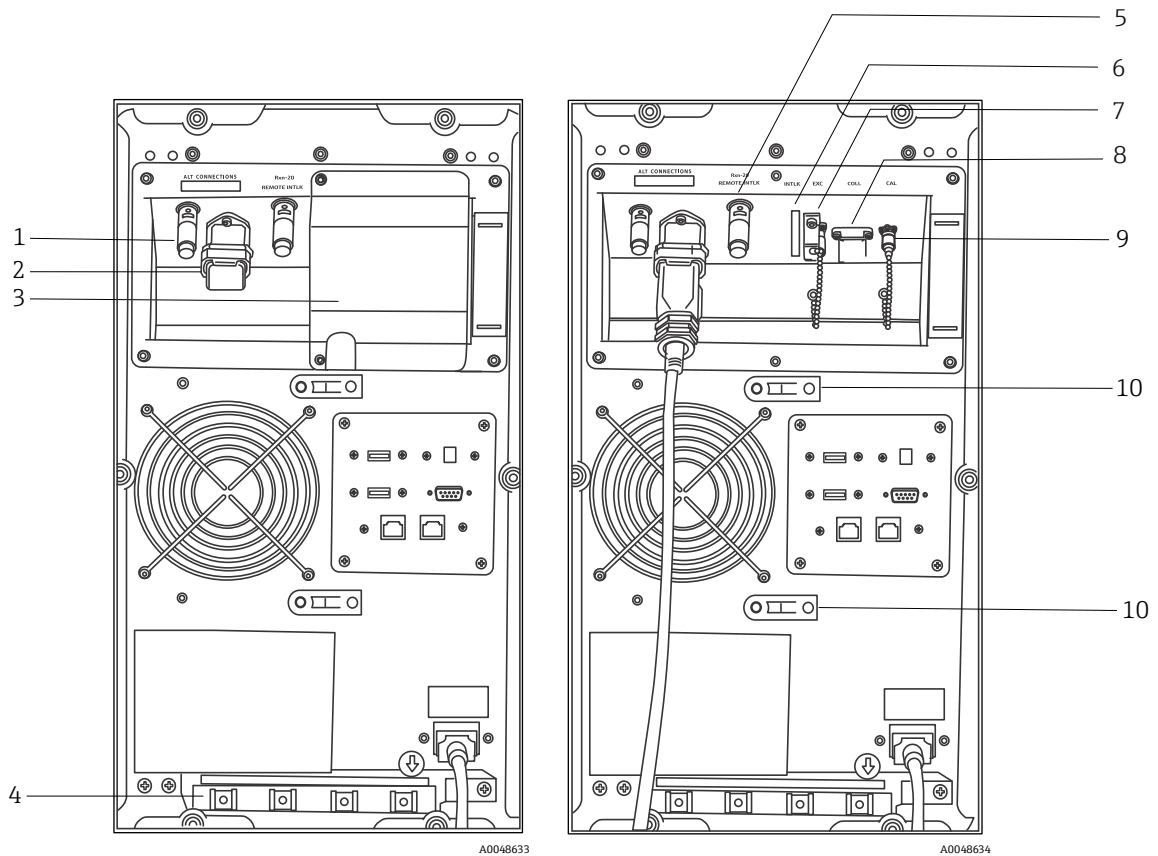

Figure 19: Rear panel of Raman Rxn2 hybrid configuration with Rxn-20 channel cover attached (left) and removed (right)

#	Description
1	Remote interlock connector (ALT channel)
2	EO fiber connection (ALT channel)
3	Rxn-20 channel cover
4	EO fiber cable strain relief (ALT channel)
5	Remote interlock connector (Rxn-20 channel)

#	Description
6	Interlock connector (Rxn-20 channel)
7	Excitation port (Rxn-20 channel)
8	Collection port (Rxn-20 channel)
9	Calibration port (Rxn-20 channel)
10	Fiber cable assembly strain relief (Rxn-20 channel)

7.2.1 Power and grounding

The Raman Rxn2 has a standard IEC-320 C-14 inlet for power at the rear of the instrument. Any power cord with an IEC-320 C-13 plug will connect to the base unit. The Raman Rxn2 accepts AC power from 100 to 240 V and 50/60 Hz. For U.S. applications, a power cord is supplied. For non-U.S. applications, the user must supply a power cable that meets local/national standards.

Also included on the rear of the instrument is a functional earth terminal for additional grounding if required. Primary grounding occurs through the IEC power inlet plug ground terminal which should be connected to the building grounding system.

Do not position the Raman Rxn2 in a way that makes it difficult to remove the mains cord. Only use adequately rated power cables with the Raman Rxn2 system.

7.2.2.3 Raman Rxn2 hybrid configuration

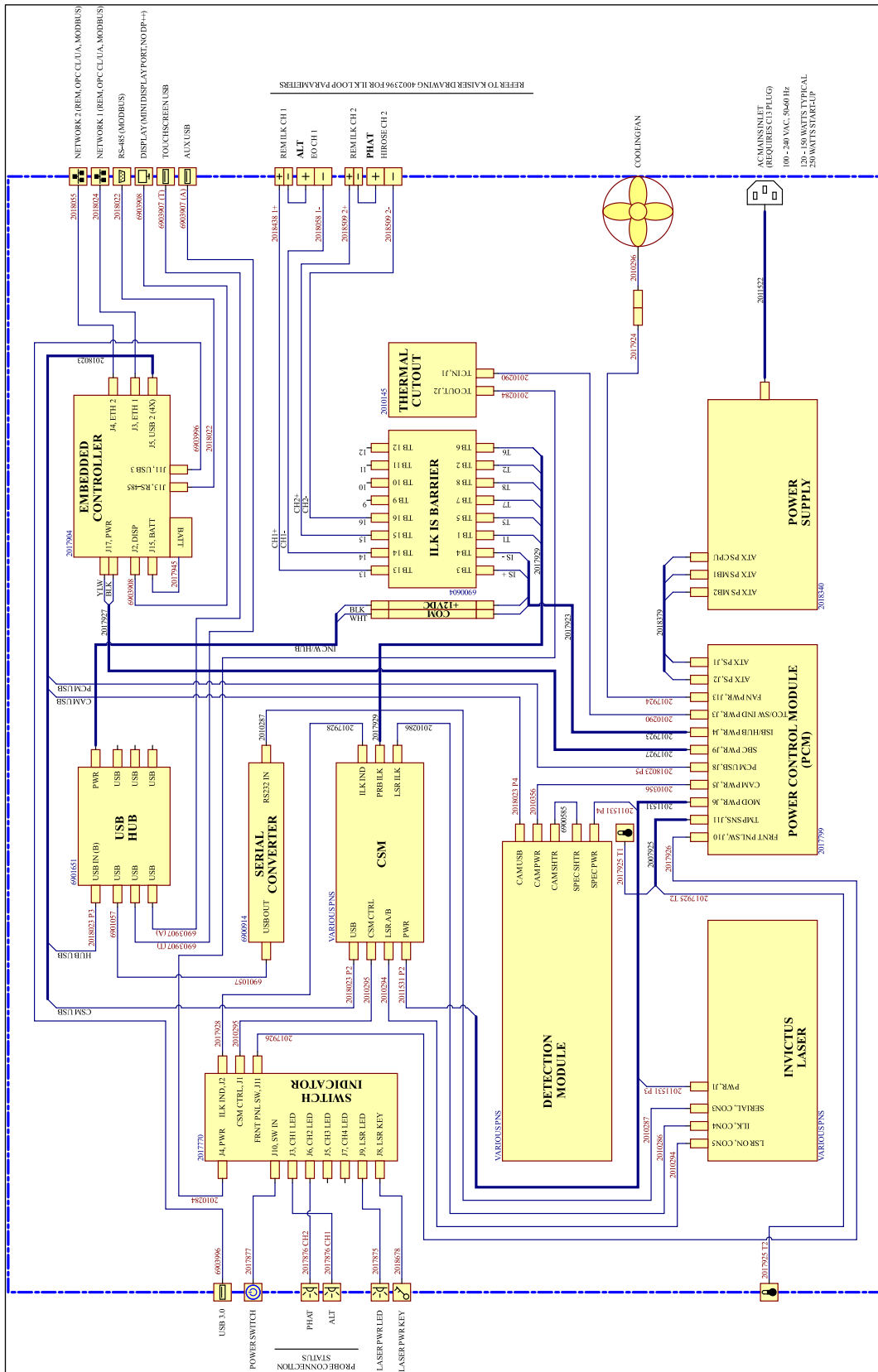

A0054424

Figure 22: Raman Rxn2 hybrid configuration

7.2.3 Hazardous area installation drawing

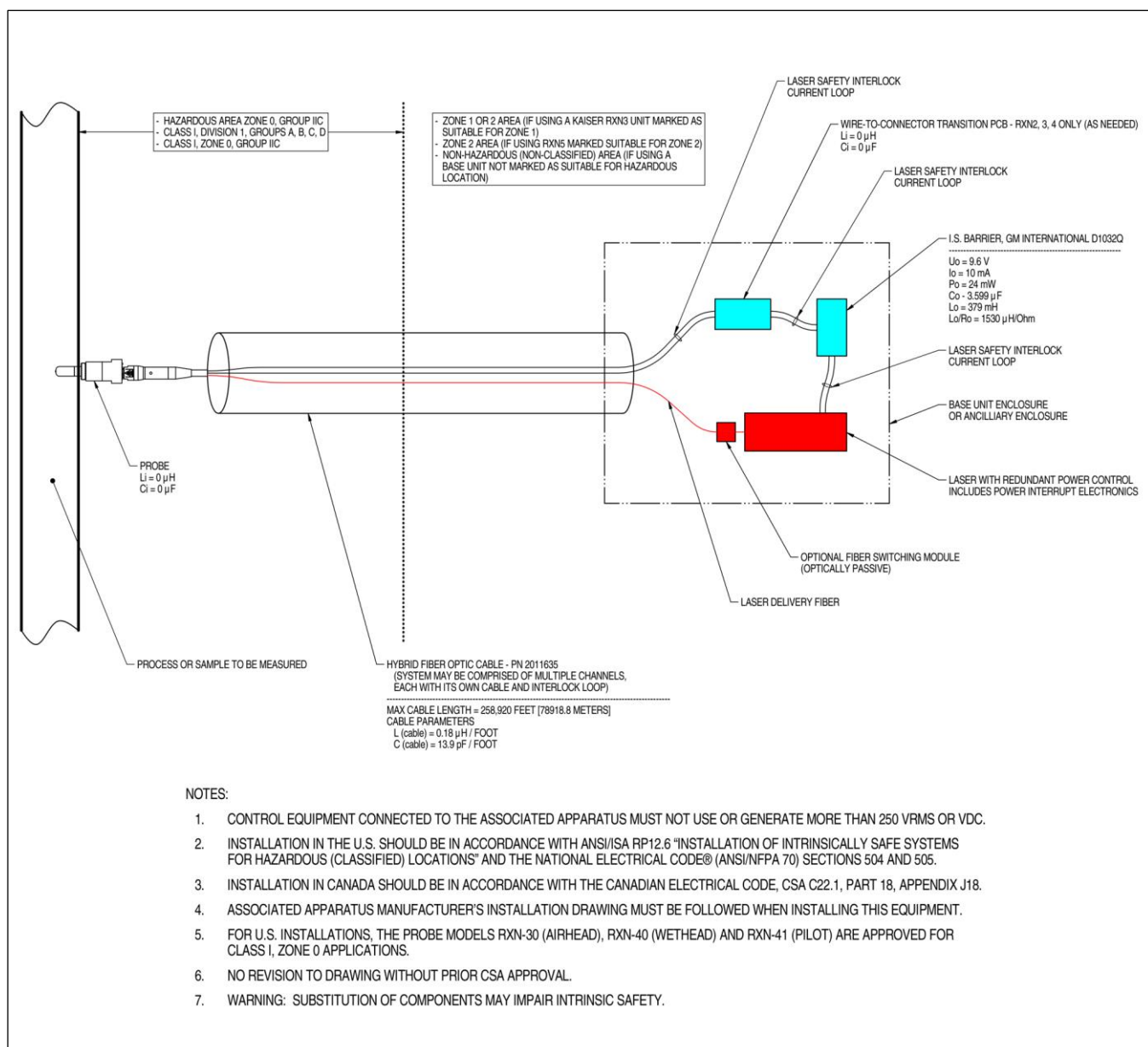

A0049010

Figure 23: Hazardous area installation drawing (4002396 X6)

7.2.4 Remote laser interlock connectors

Adjacent to each instrument probe connector resides a remote interlock connector. This connector allows integrators to access the analyzer's individual channel interlock circuit, and connect external switching devices, such as the emergency stop button and door switch, as additional means to stop laser radiation for each channel. This connector is in series with the associated channel's probe connector interlock loop. The output of this connector is intrinsically safe. Connection of external devices, including cabling, to this connector are governed by drawing 4002396.

The instrument ships with shorting plugs installed in each channel's remote interlock connector. Should field wiring be required for an external switch, a remote interlock pigtail may be purchased to facilitate connection to field wiring using *p/n 70189075 (single pigtail)* or *p/n 70189076 (four pigtails)*. Replacement shorting plugs may be purchased using *p/n 70193450*.

If one emergency switch is required to interrupt all four channels of a four-channel instrument simultaneously, a 4-pole switch shall be used. The four separate interlock loops are electrically isolated and may NOT be tied together electrically. Endress+Hauser recommends IDEC XN1E-BV404MR for a 4PST-NC emergency stop button switch.

Refer to drawing 3000095 for remote interlock connection details.

7.3 Interior of the Raman Rxn2

The interior of the Raman Rxn2 with the cover removed is shown below. The internal components are common among all configurations.

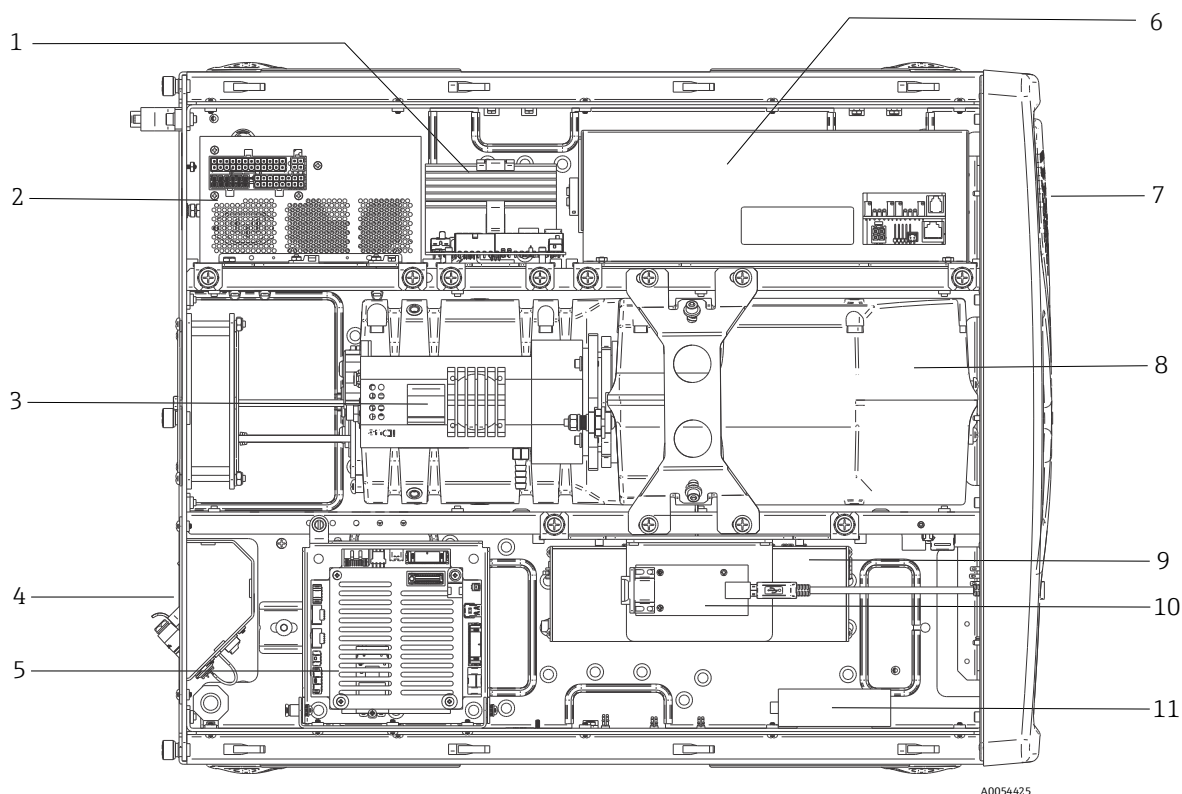

Figure 24: The interior of the Raman Rxn2 analyzer

#	Description
1	Power control module (PCM)
2	Power supply
3	Internal temperature sensor
4	Excitation and collection fiber optics
5	Embedded controller
6	Laser module
7	Air inlet with incorporated ambient temperature sensor
8	Spectrograph module
9	CSM module
10	Serial converter
11	USB hub

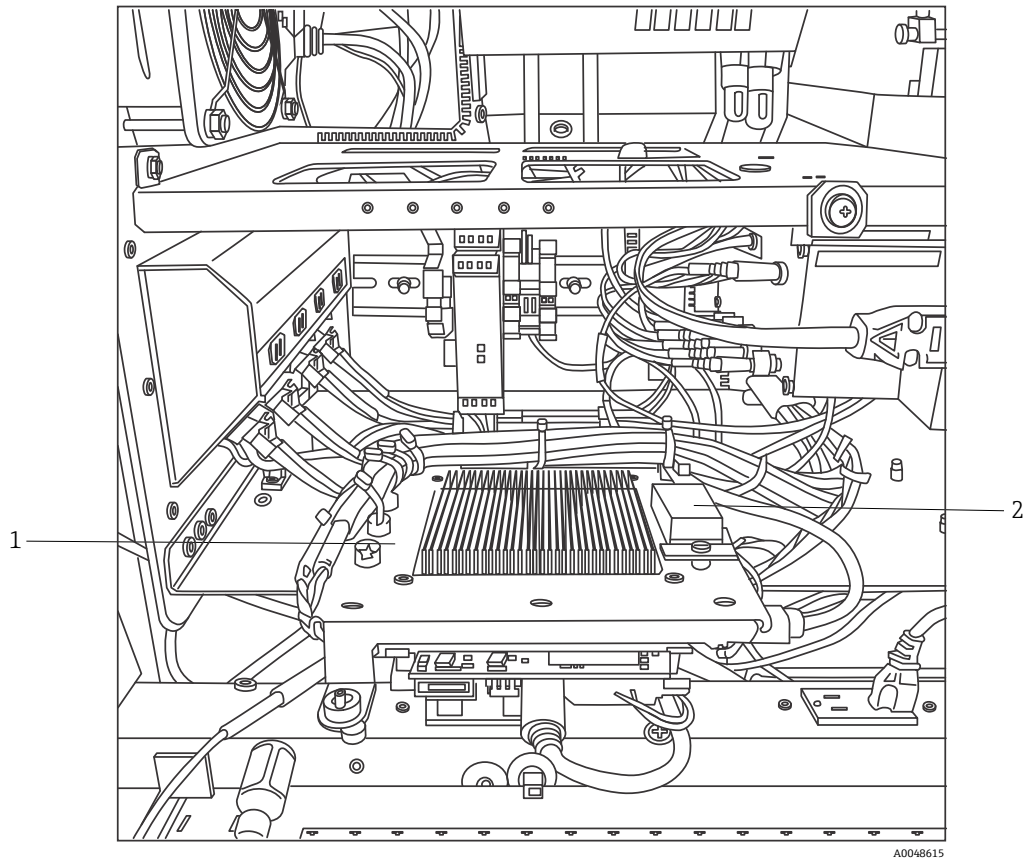

Figure 25: Embedded controller locked in service position

#	Description
1	Interlock IS barrier
2	Embedded controller backup battery

7.4 Raman Rxn2 hardware components

7.4.1 Laser

The laser used in the Raman Rxn2 is a special version of Endress+Hauser’s Class 3B laser. It has a lockable injector that requires no routine adjustment.

The laser can be turned on and off using the LASER ENABLE switch on the front of the base unit at any time while the Raman Rxn2 is operating.

7.4.1.1 Laser apertures

Apertures for laser emission are found in the following places on and within the Raman Rxn2:

- Probe head
- Connection panel
- Calibration module
- Laser

7.4.1.2 Laser interlock circuit

If an interlock in a fiber cable breaks, the laser output for that channel is disabled. Other channels with intact fiber interlocks will continue to have the laser available to them.

For laser output to occur on a channel, a probe and remote interlock shorting plug, Endress+Hauser p/n 70193450, must be installed to their respective connectors.

Auxiliary interlock laser emission indicators are located on the probes. See the specific probe operating instructions for more information.

7.4.2 Spectrograph

The spectrograph includes the optical elements used to filter out the Rayleigh scatter and focus the Raman scatter onto the detector. The spectrograph assembly (which includes the detector) in the Raman Rxn2 is contained in a sealed assembly and has no user-serviceable parts.

7.4.3 Calibration switching module

The calibration switching module (CSM) is a key component of the Raman Rxn2. Using high-reliability switches, it routes the several channels and performs automatic wavelength calibration with a neon source and laser wavelength calibration with an internal Raman shift standard. It also contains a software-controllable shutter for the laser.

The neon lamp provides a broad spectrum of lines for wavelength calibration across the Raman spectrum. The neon lamp also is not susceptible to spectral shift with changes in temperature or pressure as are calibration protocols that rely on Raman bands.

The calibration can be performed on the internal neon lamp without reconfiguring the analyzer to accommodate an external calibration unit. The internal Raman shift standard allows the laser wavelength to be tracked.

Because the calibration light source is internal to the Raman Rxn2, it is susceptible to interference from stray light entering the connected probes. Prevent stray light from entering any probe connected to the base unit by covering the ends of any attached probes that are not being used.

Refer to the Software operation chapter of the *Raman RunTime Operating Instructions (BA02180C)* for more information on calibrating the Raman Rxn2 analyzer.

7.4.4 Fuses

There are no fuses to replace on the Raman Rxn2. The Raman Rxn2 is powered by a special adapted advanced technology extended (ATX) power supply, which has no external fuses. If a short circuit were to occur inside the Raman Rxn2 it would be on the DC output side of the power supply. In this event, the power supply would turn itself off and the user must manually reset the power by removing the plug for 5 minutes after the source of the short circuit is resolved.

7.4.5 Mobile cart accessory option

An ergonomic mobile cart/trolley is available as an option for all Raman Rxn2 configurations. The Raman Rxn2 with mobile cart model includes the Raman Rxn2 embedded analyzer, built-in probe and optic storage, a routine-analysis sample compartment, and fiber storage. For connecting main power to the mobile cart, an integrated internationally approved pigtailed power cord is provided.

The pigtail incorporates a standard IEC-320 C-14 inlet to which any standard and locally approved power cord with an IEC-320 C-13 plug may be attached to provide mains power to the cart accessory. The mobile cart accepts AC power from 100 to 240 V and 50/60 Hz. Internal to the mobile cart, all mains power is distributed to the Raman Rxn2 base unit, touchscreen monitor and optional calibration accessory using an internationally approved power distribution strip with internationally approved cordage.

For mobile cart options sold within the continental United States, an approved 3 m (39.4 in) power cord is provided with the mobile cart for attachment to mains power. For mobile cart options sold outside the continental United States, a power cord is NOT included. It is the responsibility of the end user or local distributor to provide a locally approved power cord for attachment to mains power.

See the *Raman Rxn Mobile Cart Operating Instructions (BA02175C)* for more information.

7.4.6 Air filter

The Raman Rxn2 incorporates a tacked polyester spun air filter element to reduce dust intake into the base unit. The air filter is accessed by a magnetically secured access panel on the front of the instrument. The air filter should be cleaned with compressed air once every month or if the embedded software is reporting an internal over-temperature error (if ambient temperature is within specification). In extremely dusty conditions, the air filter should be cleaned more often. The air filter has a blue tacky side which should be oriented toward the outside of the base unit.

If a replacement air filter (p/n 70207492) is needed, refer to our website (<https://endress.com/contact>) for the list of local sales channels in your area.

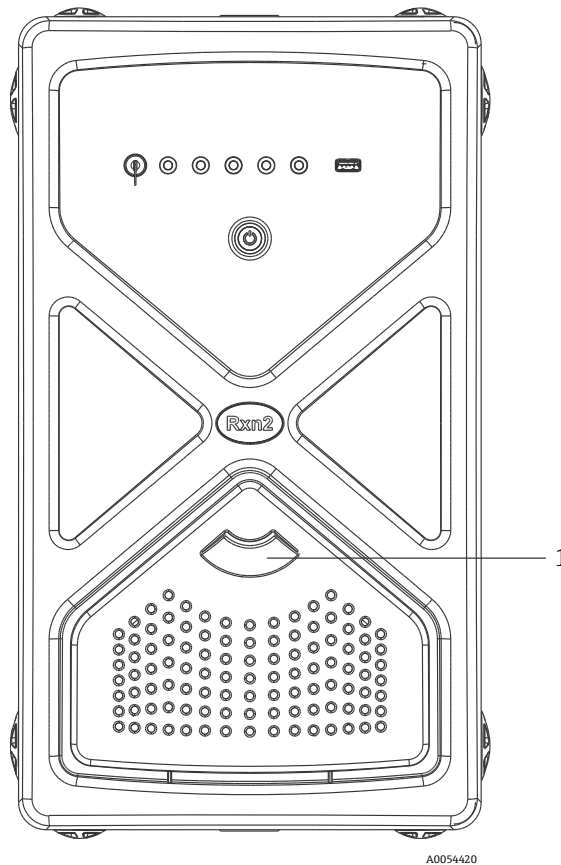

A0054420

Figure 26: Pull (1) for access to air filter

8 Operation

WARNING

- ▶ Whenever the Raman Rxn2 analyzer main power switch and laser key are turned **ON**, any attached probes should be shuttered or covered, or remain immersed in the sample to be measured.

8.1 Raman RunTime embedded software

Raman RunTime is the embedded control software installed on all the Raman Rxn2 analyzers. It is intended for easy integration with standard multivariate analysis and automation platforms to enable a real-time, *in situ* process monitoring and control solution. Raman RunTime presents an OPC and Modbus interface which provides clients with analyzer data as well as analyzer control functions. Please refer to the *Raman RunTime Operating Instructions (BA02180C)* for complete instructions on configuring and using the Raman Rxn2 with Raman RunTime.

8.2 Initial Raman RunTime setup

To perform initial Raman RunTime software setup, follow the instructions below.

1. Customize the analyzer name. The default name is “Raman Analyzer”:
 - From the Raman RunTime dashboard, navigate to **Options > System > General**.
 - Click the **Instrument Name** field.
 - Enter a custom name, for example, Raman Rxn2-785 SBAAAF12000, then click **Apply**. The analyzer name is how the system is identified in diagnostic exports and within calibration reports.
2. (Optional) Calibrate the touch screen:
 - From the dashboard, navigate to **Options > System > General > Calibrate Touch Screen**.
 - Follow the on-screen prompts. To achieve better calibration, use the edge of your fingernail when following on screen prompts and touching the requested touch points.
3. Customize the identity for communication protocols, and customize network settings:
 - Navigate to **Options > System > Network**.
 - Click the **Hostname** field.
 - Enter a custom name and click **Apply**. This is a critical step because the hostname is how the Raman Rxn system is identified through communication protocols.
If using DHCP, the IP address is obtained automatically.
 - (Optional) Enter the static IP information, as applicable, then click **Apply**.
4. Set the date and time:
 - From the dashboard, navigate to **Options > System > Date & Time**.
 - Specify the time, date, and time zone, or
 - Enable **Time Synchronization**. Provide a time server address on the local network.
 - Click **Apply**.
 - ▶ If setting the date and time manually, ensure the time zone is set up correctly before proceeding to other adjustments.
 - ▶ This is another critical step because spectral acquisition and resulting files and communication protocols are managed by the system’s date/time.

5. Specify names for each probe/quadrant such as Probe 1, Probe 2:
 - From the dashboard, click the title bar of the probe you wish to name. The stream or probe detail view displays.
 - Select the **Settings Tab** and click **Name**.
 - Enter the name of the probe and click **Apply**.
 - Let the system stabilize for at least two hours before proceeding to calibration.
6. Refer to the *Raman RunTime Operating Instructions (BA02180C)* for initial calibration and verification instructions.

8.3 Calibration and verification

Reliable, transferable calibration is important for comparing data acquired at various times or with different analyzers. Different instruments analyzing the same sample can generate nearly identical spectra if they are properly calibrated. The Raman RunTime software package includes an automatic calibration wizard that guides you through a procedure to automatically calibrate the wavelength and intensity axes and the wavelength of the laser.

After the initial calibration during installation, the Calibrate Periodically function is usually sufficient to maintain the wavelength and laser calibration of the Raman Rxn2.

A summary of the recommended calibration and verification sequence is as follows:

1. Internal calibration
2. Probe calibration
3. Probe verification

8.3.1 Internal calibration

Raman Rxn2 analyzers have internal calibration standards for spectrograph and laser wavelength. The internal calibration options are:

- **Automatic.** If the instrument is already calibrated, this setting compares the current analyzer response to calibration specifications and applies an algorithmic correction if it is minorly out of specification. This setting also recalibrates if the spectrograph wavelength, laser wavelength, or both are out of specification. If the analyzer is uncalibrated, this performs an alignment calibration, followed by a full wavelength calibration and full laser wavelength calibration.
- **Recalibrate X Axis.** Forces full wavelength and laser calibrations without first checking whether the analyzer is within spec.
- **Recalibrate All.** This setting causes the alignment calibration to be repeated prior to performing full spectrograph wavelength and laser wavelength calibrations. Note that when **Recalibrate All** completes, the intensity calibrations and verifications of all probes are invalidated.

Refer to the Calibration and verification section of the *Raman RunTime Operating Instructions (BA02180C)* for steps to perform or set periodic internal calibrations.

8.3.2 Probe calibration

The sensitivity of the Raman Rxn2 varies with wavelength due to variations in the throughput of the optics and the quantum efficiency of the CCD. The probe calibration function in Raman RunTime can be used to remove the effects of this variation from measured spectra.

Probe calibration for Raman Rxn2 analyzers can be performed using a probe-specific calibration kit or the HCA Raman calibration accessory. Refer to the applicable probe or optics manual to determine the appropriate calibration accessory. Refer to the calibration accessory manual for details on how to calibrate the specific analyzer/probe combination. Each channel must be probe-calibrated separately.

Probe calibration can be performed during active experiments, for example when a probe needs to be set up while another probe is active. When a probe calibration is triggered, any acquisitions currently in progress are aborted automatically, and the calibration proceeds. Upon completion of the calibration, active probes automatically resume normal operation.

8.3.3 Probe verification

The probe verification wizard may be used to verify that the Raman Rxn2 is performing within specifications. Probe verification acquires a Raman spectrum of a standard Raman sample, usually 70 % IPA or cyclohexane, and analyzes the resultant spectrum for peak positions, peak area ratios and Raman signal strength. The peak position verification confirms that the spectrograph and laser wavelength calibrations are within specification. The peak area ratio verification confirms that the probe intensity calibrations are within specification. The signal strength verification confirms that the instrument's signal-to-noise ratio is within specification. A report is generated showing the results of the verification steps along with a Pass/Fail indication.

This step is not required to collect a Raman spectrum, but it is highly recommended. Refer to the applicable probe or optics manual to determine the appropriate verification accessory, acceptable reference samples, and for information about how to verify the specific analyzer/probe combination.



9 Diagnostics and troubleshooting

Raman RunTime provides diagnostic information to help determine troubleshooting required on the analyzer. Refer to the System warnings and errors section of the *Raman RunTime Operating Instructions (BA02180C)* for additional information.

9.1 Warnings and errors

9.1.1 System status

The **Status** button in the middle of the main view Status bar displays the current state of the system.

Symbol	Description
	When the system is fully calibrated and operating as expected, the Status button in the middle of the main view status bar reads OK and appears Green .
	If a system warning is encountered, the Status button changes to Yellow . Warnings should be acknowledged but immediate action may not be necessary. Click the Status button to view details of the warning. The most common warning occurs when all the channels are not occupied. The button pulses continuously until the problem is resolved. Click the Status button to view details about the warning.
	If a system error is encountered, the Status button changes to Red . An error requires immediate action to restore system performance. Click the Status button to view details about the error.

9.1.2 Uncalibrated channels

In some cases, users may choose not to utilize all available channels on a Raman Rxn2 analyzer. These unused/uncalibrated channels may result in warnings generated, thereby putting the whole system in a warning state. To resolve these erroneous warnings about unused channels not being calibrated, the user can individually turn off unused probes/channels in the **Options > Calibration** screen and select the **ON/OFF** marker beneath each probe's number.

If a system error is encountered, the **Status** button changes to **Red**.

1. Click the **Red** status indicator to view details about the warning or error.
2. In the event the analyzer stops communication with the interface, go to **Options**, select **System**, choose **Restart** and the analyzer reboots. This re-establishes camera/interface communication.

9.1.3 Low laser power

To check laser environment data, go to the **Options > Diagnostics > Environment** tab.

If low laser power is suspected due to low signal in the Raman spectra, check the Laser Power diagnostic as highlighted in the figure below. The laser power should register within 10 mW of the laser power setpoint.

Laser diode current increases over time due to normal diode aging. Raman RunTime provides a warning when laser diode current reaches 80 % of its current limit, and an error when it reaches 90 % of its limit. In each state Raman RunTime recommends service of the laser module. When the laser diode current reaches its limit, the laser is in a failure state and laser power gradually starts decreasing. For Technical Service, refer to our website (<https://endress.com/contact>) for the list of local sales channels in your area.

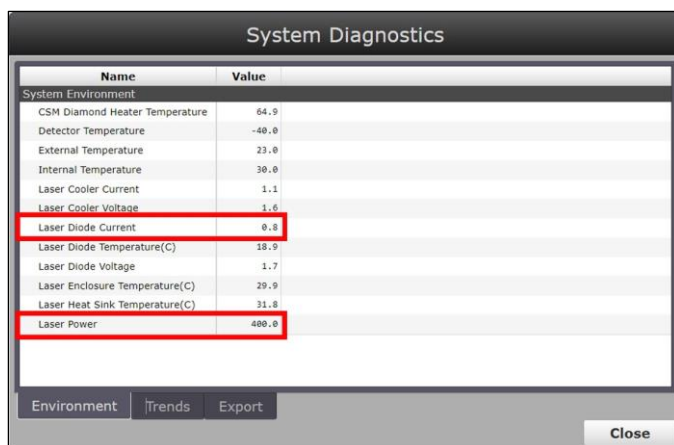

A0049222

Figure 27: Environment tab to view laser diode current and laser power

9.1.4 ON/OFF button flashing

The ON/OFF button emits a flashing blink code to communicate a problem when the software is unavailable.

Sign	Problem	Solution
2 blinks in quick succession followed by a solid long pause.	Indicates problem with main power supply. Could indicate power has been interrupted. Flashing ceases when reserve power is depleted if it is not replenished.	Check the security of the power cord and its connection. If there is no facility power outage, problem could be with power unit and a replacement is necessary. Call service.
3 blinks in quick succession followed by a solid long pause	Indicates the system has detected a problem with the main power supply and has attempted to restore normal power supply operation without success.	There is likely a problem with the main power supply and a replacement is necessary. Call service. Operation may be temporarily restored with the following procedure: Unplug the power cord from the instrument until the power button stops blinking, then reconnect the power cord. If the instrument powers up normally, continue to use while waiting for the replacement power supply.
6 blinks in quick succession	It is too hot inside the instrument. The device is rated for an environment up to 35 °C (95 °F). Instrument shuts down its power source when it is too hot.	Check ambient temperature in the environment around the instrument. If the temperature does not exceed the rated limit, call service.

9.1.5 Quick reference troubleshooting

Diagnostic Title	Solution
Probe is not emitting laser	Check whether the probe is connected properly. Confirm that laser key is turned ON and indicator light is lit. Inspect whether the shutter switch is in the ON position. Examine whether the remote unlock connector is present on specific channel.
Raman RunTime is frozen and not responding	Reboot device by holding the ON/OFF button on the front of the device for 12 seconds until it powers down. Release power button. Depress power button momentarily to power the device back up.
Raman RunTime reports a detector temperature warning	Camera hasn't had time to cool down. The camera usually needs 20 to 25 minutes from when it powered up to cool down to the proper temperature.
The probe fiber is broken	A broken fiber cable will open the interlock and turn the laser off. For Technical Service, refer to our website (https://endress.com/contact) for the list of local sales channels in your area.
The laser has failed	Check Options > Diagnostics for a reading on the laser's current and power. For Technical Service, refer to our website (https://endress.com/contact) for the list of local sales channels in your area.
Raman RunTime will not initialize	Follow instructions in the Restore section of the Recovery Console to restore an export file already saved that contains settings, calibrations, and verification data.

9.2 Raman Rxn2 system and power loss

The instrument retains its last known power state in non-volatile memory. Should power be interrupted to the instrument at any time, the instrument will recall its last known power state and return to that power state once power is restored. For example, if the instrument was ON when power was interrupted, it will power on automatically once power is restored. If the laser was ON and the laser key is also in the ON position as well, then the laser will turn on. In the unlikely event of this occurring, this represents a possible laser exposure hazard. While power is interrupted, if the instrument was ON at the time of power loss, the power switch will flash a two-blink error code for 30 to 60 seconds, indicating that power has been lost.

10 Maintenance

10.1 Optimization

If you move the Raman Rxn2, it may be necessary to re-optimize its performance. First, re-verify its performance using Raman RunTime and compare the results for the current to the previous verification. If the signal intensity has dropped significantly, you may benefit from following the optimization guidelines below.

10.1.1 Sample position

If the sample has been moved from the focal point of the probe, less Raman scattering is recovered by the probe and transmitted to the spectrograph. This is the easiest area to check first.

Perform the following procedure in a darkened room:

1. Click **Focus** on the Stream Detail View.
2. Watch as the signal increases and decreases in response to the sample movement in front of the probe.
3. Be aware of any potential laser light reflected off the sample container during this procedure.

WARNING

- ▶ The Raman Rxn2 uses a Class 3B laser as defined in [ANSI Z136.1: Safe Use of Lasers](#). Direct eye contact with the output beam from the laser will cause severe damage and possible blindness. Always be aware of the initial direction and possible reflection or scattering paths of the laser.
- ▶ Refer to the *Raman Rxn2 Safety Instructions* and the probe-specific safety instructions for additional laser safety information.

10.1.2 Cleaning the lens or window

If the lens or window on the probe/optic is contaminated by the process, dust, or fingerprints, it needs to be cleaned. Refer to the applicable probe or optics manual for cleaning instructions.

10.1.3 Detector camera alignment

If the Raman Rxn2 spectrograph internal optics have shifted, the detector camera alignment may need to be changed.

CAUTION

- ▶ The CCD camera alignment is set at the factory and rarely needs to be altered in the field. Alignment should be performed only by experienced personnel.

Prior to performing a camera alignment operation, it is important to ensure that no stray light is entering any of the probes that are attached to the Raman Rxn2. Alignment is performed with an internal white light source, and stray light entering on any of the attached probes can interfere with the alignment light source.

To perform the camera alignment:

1. Navigate to **Options > Calibration**.
2. Click **Calibrate** under the Internal Calibration section then select **Recalibrate All** from the Calibration Mode drop-down list. Click **Calibrate**.

All probe calibrations and verifications are invalidated after Recalibrate All and need to be re-performed. See *Calibration and verification* →  for additional instructions.

10.2 Real-time clock backup battery replacement

The Raman Rxn2 analyzer contains a AA-sized SAFT LS 14500 3.6V Li-SOCl₂ cell type battery. Replacement of the battery is intended to be done only when the analyzer is disconnected from power and fiber optic cables.

- Test the replacement battery using a battery test meter prior to installing the battery.
- Make sure you disconnect the power for at least 10 seconds, or after all capacities inside have been drained.

⚠ WARNING

Controller assembly contains a battery manufacturer/type: SAFT LS 14500 3.6V Li-SOCl₂. Replacement batteries must be identical. Failure to observe this warning will invalidate the governing certificates.

1. Remove the cover.
 - Lay the Raman Rxn2 on a benchtop horizontally in the orientation shown with the cooling fan screen toward the top.

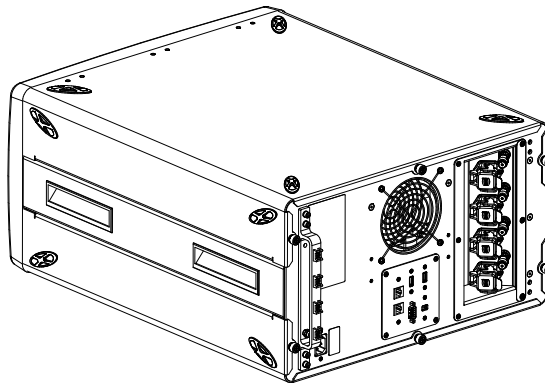

Figure 28: Raman Rxn2 on a benchtop horizontally

A0055212

- Loosen 3 captive thumbscrews at rear of Raman Rxn2 top cover.

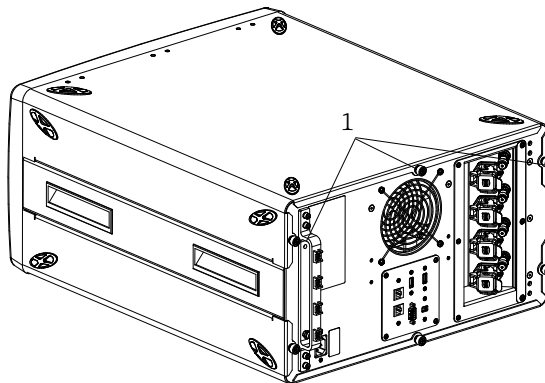

Figure 29: Raman Rxn2 captive thumbscrews (1)

A0055212

- Slide cover toward the rear approximately 6.4 mm (0.25 in) until it stops to disengage clips that secure cover to the black side rails.

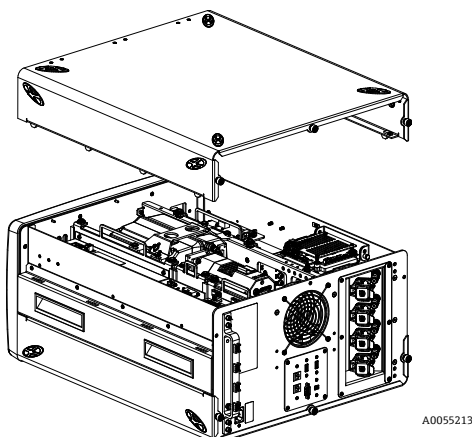

Figure 30: Raman Rxn2 slide cover toward the rear

- Locate the embedded controller plate.

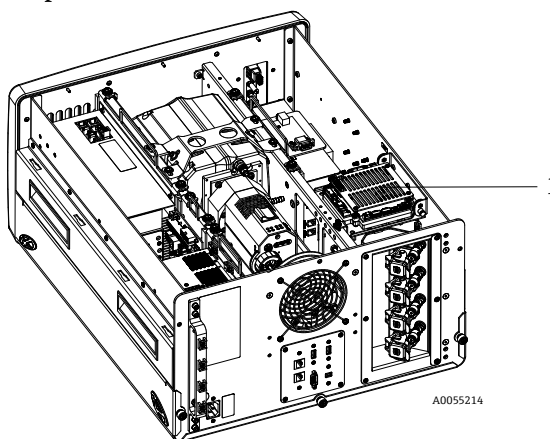

Figure 31: Rear overview with controller plate in normal position (1)

- Loosen the captive screw securing the embedded controller plate.

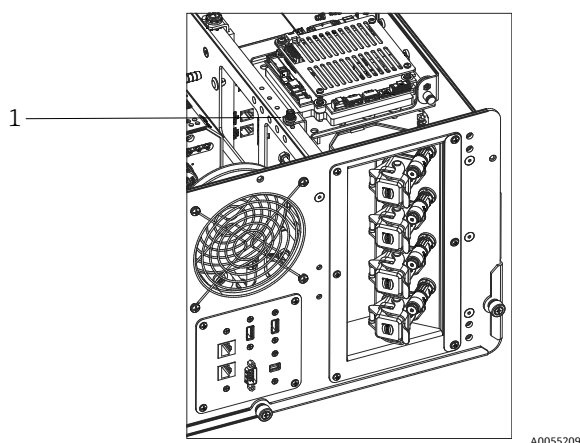

Figure 32: Captive screws securing the embedded controller (1)

- Pull on the locking pin (1) and lift by the captive screw (2) on the controller plate to rotate the controller plate 90 degrees. Release the locking pin to lock the controller plate in the up position.
 - The SAFT battery is now visible and accessible.

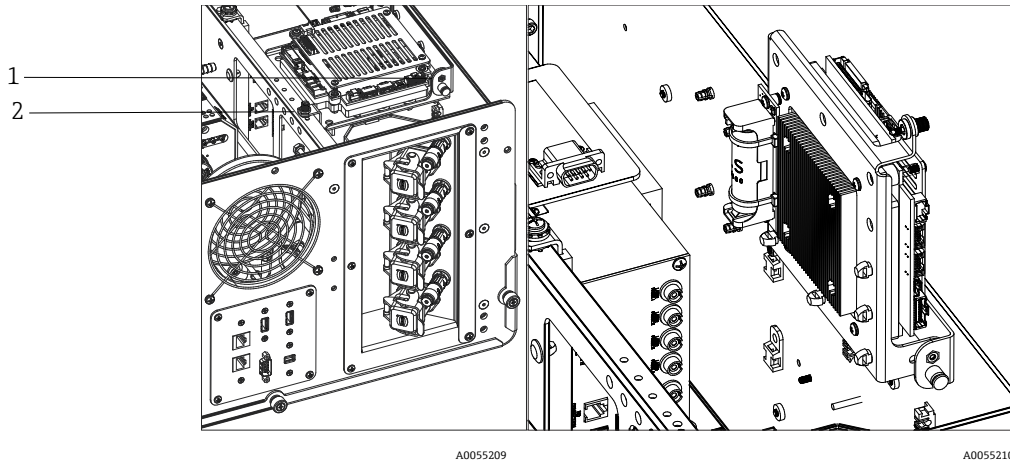

Figure 33: Rear overview with controller plate in the open position

6. Remove the 2 cable ties holding the battery in the polarized holder.

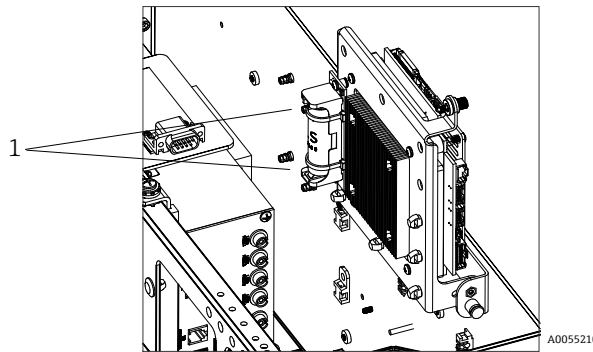

Figure 34: Remove cable ties holding the battery

7. Remove battery.
8. Replace ONLY with a new AA-sized SAFT LS 14500 3.6V Li-SOCI2 cell type battery by inserting it in the polarized holder in the correct orientation.
9. Secure the new battery in the polarized holder with 2 new small cable ties.

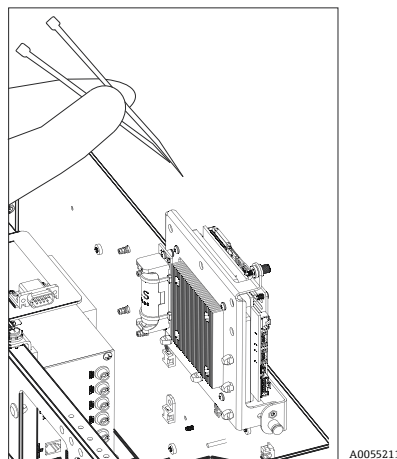

Figure 35: Secure the new battery with cable ties

10. Flip controller down and tighten the hand screw back into rail.
11. Replace cover.

- Set the cover on top of the Raman Rxn2, ensuring the front of the cover is flush with the rear of the front face plate and holes in the side of the cover are aligned with the threads that accept the cover fasteners.
- Loosen 3 captive thumbscrews previously removed to secure the cover.

10.3 Servicing the Raman Rxn2 analyzer

Some of the service procedures require removal of the protective cover. Special precautions are therefore necessary to deal with the added optical and electrical hazards that are present during service operations.

⚠ WARNING

General users should not open the Raman Rxn2 enclosure due to potential exposure to hazardous laser radiation or high voltages.

- ▶ Only qualified personnel familiar with high voltage electronics should open the system enclosure to perform necessary maintenance or service.

Raman RunTime also provides diagnostic information to help determine service required on the analyzer. Refer to the System warnings and errors section of the *Raman RunTime Operating Instructions (BA02180C)* for additional information.

For Technical Service, refer to our website (<https://endress.com/contact>) for the list of local sales channels in your area.

Symptom	Possible cause	Description (if applicable)	Troubleshooting
Raman spectra contains non-random noise	The intensity calibration file is no longer valid	The intensity calibration file is a map of the total instrument response of the system (CCD quantum efficiency, grating and lens efficiencies, etc.). If the spectrograph focal plane shifts with respect to the CCD detector, then the intensity calibration map is no longer correct. An incorrect intensity calibration file will not remove pixel-to-pixel sensitivity variation, which is as high as 3 % for some CCD chips. Shifting of the spectrograph focal plane on the CCD detector can result from adjusting the Raman Rxn2 spectrograph alignment, mechanical shock applied to the Raman Rxn2 or substantial ambient temperature shifts.	Recalibrate the intensity axis.
	The intensity per pixel per accumulation exceeded the half-well potential of CCD pixels during the creation of the intensity calibration file	Non-linearity reduces the effectiveness of the intensity calibration file at correcting the CCD pixel-to-pixel sensitivity variation	Recalibrate the intensity axis.
Intensities in Raman spectra show non-linear behavior or Raman peak shapes are distorted	The signal from the CCD can become slightly non-linear as the photo-generated charge approaches the full-well potential.	This can cause non-linear behavior and peak distortion in Raman spectra.	Repeat the data acquisition using a shorter data acquisition time and perhaps more accumulations (which adds intensities in the embedded software rather than on the CCD chip).

Symptom	Possible cause	Description (if applicable)	Troubleshooting
	The intensity calibration file is invalid.	If the intensity calibration was made using a light source that did not evenly illuminate the entire collection lens of the spectrograph, then any experiment that does not reproduce the exact uneven illumination at the time of the intensity calibration will not have the same instrument response and therefore will not be properly corrected.	Recalibrate the intensity axis.
Raman RunTime reports a detector temperature warning	The camera has not had time to cool down.	The camera usually requires 15 to 20 minutes from the time it is powered up until it has cooled down to the proper temperature.	Allow time for cool down.
Several sharp artifact peaks appear in all Raman spectra	The room lights are introducing an emission line spectrum into the spectrograph.	Turn off any fluorescent lights during future experiments. Cover reactor with aluminum or other light-blocking material to prevent light entering.	
The number of intensity counts from verification is significantly less than specification	The sample is not in the focal plane of the fiber-optic probe.	Adjust the position of the sample with respect to the probe focus.	
	The fiber-optic cable is not attached correctly to the Raman Rxn2 base unit.	Check fibers for proper engagement and that they are latched.	
	The laser power reaching the sample is too low.	Measure the laser power at the sample and compare it to the normal power for your configuration. Contact Technical Service.	
Spectrum sits on top of a broad featureless halo	Probe tip may be fouled.	Pull probe from process and clean the probe per the appropriate service manual instructions. Contact Technical Service.	
No laser light reaches the sample	The laser is not on.	Check to see if the laser key is in place and the indicator is lit.	
	The laser is not lasing.	Contact Technical Service.	
	The internal power plug has disconnected from the laser.	Open the Raman Rxn2 base unit enclosure. The computer-style power cord should be firmly plugged into its socket on the laser.	
	The fiber-optic cable is not attached correctly to the Raman Rxn2 base unit.	Check hybrid fibers for proper engagement and that they are latched.	
	The laser injector is misaligned.	Contact Technical Service.	
	The remote interlock connector shorting plug is unplugged.	Make sure the remote interlock connector shorting plugs for all channels are installed. Make sure the corresponding front panel interlock indicators are illuminated.	
	The probe fiber is broken.	The interlock cuts power to the system if the cable is broken. Contact Technical Service.	
	The Calibration Switching Module has failed.	Contact Technical Service.	
	The laser has failed.	Check Options > Diagnostics for laser diode current and power.	

Symptom	Possible cause	Description (if applicable)	Troubleshooting
Raman RunTime indicates an excessive number of tracks found during Recalibrate All	Stray light from connected probes are entering spectrograph during camera alignment.	Cover all connected probe optics to prevent any stray light from entering the spectrograph.	
Raman RunTime indicates a failure during wavelength calibration	Stray light from connected probes is entering spectrograph during calibration.	Wavelength calibration is performed with a light source internal to the Raman Rxn2 base unit. If stray light from connected probes can enter the spectrograph, it may interfere with the internal calibration lamp.	Cover all unused but connected probe optics to prevent any stray light from entering the spectrograph. Also, ensure that probes being used for sampling are protected from stray light.
Raman RunTime indicates internal temperature error	The filter needs attention.	Clean or replace the filter.	
	The ambient temperature is above 35 °C (95 °F).	Lower the ambient temperature to a temperature within the specified ambient temperature range.	

11 Repair

11.1 Servicing and spare parts

The two main user-serviceable or replaceable parts are the disposable air filter and the laser. Part numbers for these items are listed in the table below. The laser assembly has been designed for easy replacement and this is typically accomplished by the customer. Optionally, an Endress+Hauser service engineer can install the laser during a contracted service visit.

NOTICE

- ▶ The performance of procedures (including service), the use of controls, or the adjusting of the instrument other than as specified in the manual will void the warranty.

The following table provides a list of common parts that may be ordered and installed.

Part Number	Description
70207492	One packet of replacement air filters for a Raman Rxn2 analyzer (quantity 5 filters)
70187742	Embedded NIR 785 nm diode laser for Raman Rxn2 features: <ul style="list-style-type: none"> ▪ Laser wavelength: 785 nm ▪ > 125 mW of 785 nm laser power delivered to the probe* ▪ Integrated holographic laser bandpass filter ▪ Universal laser injector assembly ▪ 1-year unlimited hours warranty *Using standard multi-mode optical fiber
70199182	Embedded 532 nm frequency doubled diode-pumped Nd:YAG laser for Raman Rxn2 analyzer features: <ul style="list-style-type: none"> ▪ Laser wavelength: 532 nm ▪ Diode-pumped Nd:YAG laser ▪ 150 mW laser head output ▪ 1-year/5000 hours warranty ▪ > 80 mW of 532 nm laser power delivered to the probe* *Using standard multi-mode optical fiber
70187743	Embedded NIR 993 nm diode laser for Raman Rxn2 analyzer features: <ul style="list-style-type: none"> ▪ Laser wavelength: 993 m ▪ > 150 mW of 993 nm laser power delivered to the probe* ▪ Integrated holographic laser bandpass filter ▪ Universal laser injector assembly ▪ 1-year unlimited hours warranty *Using standard multi-mode optical fiber

For Technical Service, refer to our website (<https://endress.com/contact>) for the list of local sales channels in your area.

12 Technical data

12.1 Specifications

Raman Rxn2 analyzers may be configured to operate with one of several different laser wavelengths. Currently, Raman Rxn2 analyzers may be equipped with a 532 nm, 785 nm, or 993 nm laser as standard.

12.1.1 Base unit

Item	Description
Operating temperature	15 to 30 °C (59 to 86 °F)
Storage temperature	-15 to 50 °C (5 to 122 °F)
Relative humidity	20 to 80 %, non-condensing
Warm-up time	120 minutes
Operating voltage	100 to 240 V, 50 to 60 Hz, ±10 %
Transient over-voltages	Over-voltage category 2
Power consumption	400 W (maximum) 250 W (typical startup) 120 W (typical running)
Benchtop model dimensions (width x height x depth)	279 x 483 x 592 mm (10.99 x 19.02 x 23.31 in)
Cart model dimensions (width x height x depth)	685 x 1022 to tabletop x 753 mm 26.97 x 40.24 to tabletop x 29.65 in
Weight	
base unit	32 kg (71 lbs)
cart model	93 kg (205 lbs)
Sound level (from operator's perspective)	58.9 dB, A-weighted
IEC 60529 rating	IP20
Altitude	Up to 2000 m
Pollution degree	2

12.1.2 Spectrograph

Item	Description
Type	Proprietary axial transmissive
Aperture ratio	$f/1.8$
Focal length	85 mm
Grating (1 or 4 channels, 532 nm, 785 nm)	HoloPlex transmissive (Raman Rxn2-785 hybrid analyzers use HoloSpec transmissive)
Grating (1 or 4 channels, 993 nm)	HoloSpec transmissive
Spectral coverage (532 nm)	150 to 4350 cm^{-1}
Spectral coverage (785 nm)	150 to 3425 cm^{-1}
Spectral coverage: Raman Rxn2 hybrid configuration (785 nm)	175 to 1890 cm^{-1}
Spectral coverage (993 nm)	200 to 2400 cm^{-1}
Slit	50 μm fixed
Spectral resolution (532 nm)	5 cm^{-1} average
Spectral resolution (785 nm)	4 cm^{-1} average
Spectral resolution (993 nm)	6 cm^{-1} average

12.1.3 Laser

Item	Description
532 nm Excitation wavelength Maximum power output Warranty	532 nm 120 mW 1 year or 5000 hours
785 nm Excitation wavelength Maximum power output Warranty	785 nm 400 mW unlimited hours for 1 year
993 nm Excitation wavelength Maximum power output Warranty	993 nm 400 mW unlimited hours for 1 year



12.1.4 Probes

Analyzer configuration	Probe compatibility
Raman Rxn2 single-channel, four-channel, and starter	Compatible with: Rxn-10 probe equipped with immersion or non-contact optics Endress+Hauser liquid phase Raman probes Endress+Hauser bioprocessing Raman probes
Raman Rxn2 hybrid	Compatible with: Rxn-20 probe and 1 other ALT probe including: <ul style="list-style-type: none"> Rxn-10 probe equipped with immersion or non-contact optics Endress+Hauser liquid phase Raman probes Endress+Hauser bioprocessing Raman probes

12.2 Certifications

Raman Rxn2 analyzers carry certifications for installation in a general-purpose zone with output into hazardous areas. For more specific information on the hazardous area rating for field measurements, refer to the Operating Instructions for the installed probe.

Certification: base unit (fiber-optic and interlock outputs only)

Certification	Marking	Temperature (ambient)
IECEX	Ex [ia Ga] [op sh Gb] IIC	5 to 35 °C (41 to 95 °F)
ATEX	 II (2)(1) G Ex [ia Ga] [op sh Gb] IIC	5 to 35 °C (41 to 95 °F)
North America	Class I, Division 1, Groups A, B, C and D or [Ex ia] Class I, Division 1, Groups A, B, C, and D: [Ex ia Ga] IIC Class I, Division 2, Groups A, B, C and D: [Ex ia Ga] [op sh Gb] IIC	5 to 35 °C (41 to 95 °F)
UKCA	 II (2)(1) G Ex [ia Ga] [op sh Gb] IIC	5 to 35 °C (41 to 95 °F)
JPEX	Ex [ia Ga] [op sh Gb] IIC	5 to 35 °C (41 to 95 °F)

13 Supplementary documentation

All documentation is available:

- On the media device supplied (not included in the delivery for all device versions)
- On the Endress+Hauser Operations App for smartphone
- In the Downloads area of the Endress+Hauser website: <https://endress.com/downloads>

Part Number	Document Type	Document Title
BA02175C	Operating Instructions	Raman Rxn Mobile Cart Operating Instructions
BA02180C	Operating Instructions	Raman RunTime Operating Instructions
KA01544C	Brief Operating Instructions	Raman Rxn2 Brief Operating Instructions
XA02700C	Safety Instructions	Raman Rxn2 Safety Instructions
TI01608C	Technical Information	Raman Rxn2 Technical Information

14 Index

- abbreviations, 5
- air
 - filter, 35
- analyzer
 - additional documents, 52
 - air filter, 35
 - battery maintenance, 43
 - four-channel, 9
 - front panel, 11
 - hybrid, 9
 - interior, 32
 - laser, 33
 - location, 16
 - power, 11
 - power down, 22
 - power loss, 41
 - power up, 22
 - rear panel, 12, 13
 - service, 46
 - single-channel, 9
 - status, 39
- battery, 43
- calibration
 - CSM, 34
 - internal, 37
 - probe, 37
- camera
 - alignment, 42
- certification
 - hazardous area, 31, 51
- certifications, 51
- commissioning, 25
- connectivity, 25
- electrical
 - block diagram, 28
 - connection, 24
- export
 - compliance, 4
- focus, 42
- four-channel
 - rear panel, 12
- fuses, 34
 - DC, 34
- hazardous area, 31
- hybrid
 - rear panel, 13
- i/o panel, 25
- interlock connector, 31
- laser, 33
 - apertures, 33
 - interlock circuit, 34
 - low power, 39
- location, 16
- mini DisplayPort, 25
- mobile cart, 34
- on/off button flashing, 40
- power, 16
 - AC, 27
 - grounding, 27
- probe
 - window cleaning, 42
- Raman RunTime
 - overview, 10
- relative humidity, 16
- remote
 - interlock connector, 31
- sample position, 42
- security
 - IT, 8
- single-channel
 - rear panel, 12
- software
 - Raman RunTime, 10, 36
- spare parts, 49
- specifications
 - base unit, 50
 - dimensions, 50
 - humidity, 50
 - laser, 51
 - operating voltage, 50
 - power consumption, 50
 - spectrograph, 50
 - temperature, 50
 - warm-up time, 50
 - weight, 50
- spectral coverage, 50
- spectral resolution, 51
- spectrograph, 34
 - aperture ratio, 50
 - focal length, 50
- symbols, 4
- technical data, 50
- temperature, 16
- touchscreen, 17, 25
- troubleshooting, 40
- us export compliance, 4
- ventilation, 16
- verification
 - probe, 38
- warnings and errors, 39

www.addresses.endress.com
