

Technical Information

Proservo NMS80

Tank Gauging



Application

Proservo NMS8x Series intelligent tank gauges are designed for high accuracy liquid level measurement in storage and process applications. They fulfill the exacting demands of tank inventory management, inventory control, custody transfer, loss control, total cost saving, and safe operation.

Typical areas of application

- Precise level, interface, and density measurement of oil (fuels), petrochemical, chemical, and alcohol
- Tank mounted intelligence makes NMS8x ideal for single or multi-task installation, covering a wide range of measurement functions including Liquid level, Interface level, Spot density, Density profile, Tank bottom, and Water dip and integrating a wide range of tank sensor measurement functions including Water level, Temperature, and Pressure.

Your benefits

- SIL2/3 certified as per IEC 61508 (Min, Max, Continuous level)
- SIL2 by single channel, SIL3 by dual channel (homogeneous or diverse redundancy)
- Measures liquid level to an accuracy of +/- 0.4 mm (0.016 in)
- Measurement of up to 2 interface levels and density of up to 3 liquid phases
- Liquid density profiling of up to 50 points throughout the tank or upper layer, configurable
- Wetted parts are completely separated from the electronic circuit
- Tank top mounting with 3" flange
- Wide range of output signals including V1, Modbus RS 485, and HART protocol
- Material and pressure rating of the wetted parts can be selected
- Suitable for atmospheric and high pressure applications up to 6 bar/600 kPa/ 87 psi
- Integration of e.g. temperature, water level, pressure, overfill prevention sensor
- Direct connection of spot or average temperature sensor
- Robust IP66/68, NEMA Type 4X/6P enclosure, stainless steel or aluminum
- Operation and display in a wide variety of local languages
- Easy commissioning, maintenance, and diagnostics via FieldCare

Table of contents

Document information	3	Viscosity	44
Symbols	3	Maximum displacer movement speed	44
Function and system design	5	Custody transfer approval	45
Measuring principle	5	Mechanical construction	46
Integration of tank sensors	6	Dimensions	46
Measuring system	14	Weight	47
Input/output	16	Materials	47
Level measurement	16	Parts according to NACE standard	48
HART Ex ia/IS active input	17	Operability	49
I/O modules	18	Operating concept	49
Power supply	27	Operating options	49
Terminal assignment	27	Local operation	49
Supply voltage	28	Remote operation	50
Power consumption	28	Operation via service interface	51
Sources for gauge commands	28	Certificates and approvals	52
Cable entries	31	CE mark	52
Cable specification	31	RCM marking	52
Overvoltage protection	31	Ex approval	52
Overvoltage category	31	Single seal according to ANSI/ISA 12.27.01	52
Pollution degree	31	Functional Safety (SIL)	52
Performance characteristics	32	WHG	52
Reference operating conditions	32	Weight & Measure approval	52
Measured value resolution	32	CRN approval	53
Maximum measured error	32	Test, certificate	53
Hysteresis	33	Other standards and guidelines	53
Repeatability	33	Calibration	54
Linearity	33	Ordering information	55
Long-term drift	33	Calibration certificate	55
Influence of ambient temperature	33	Marking	55
Influence of medium temperature	33	Shipping condition	55
Influence of medium pressure	33	Application packages	57
Effect of gas phase	33	Advanced tank measurement methods	57
Installation	34	Accessories	62
Requirements	34	Device-specific accessories	62
Environment	42	Communication-specific accessories	67
Ambient temperature range	42	Service-specific accessories	67
Classification of environmental conditions according to DIN EN 60721-3-4	42	System components	67
Storage temperature	42	Documentation	68
Humidity	42	Technical Information (TI)	68
Degree of protection	42	Brief Operating Instructions (KA)	68
Shock resistance	42	Operating Instructions (BA)	68
Vibration resistance	42	Description of Device Parameters (GP)	68
Electromagnetic compatibility (EMC)	42	Safety Instructions (XA)	68
Maximum use altitude	42	Installation instructions (EA)	68
Process	43	Registered trademarks	69
Process temperature range	43		
Process pressure range	43		
Medium density	44		
Medium density difference for interface measurement	44		

Document information

Symbols

Safety symbols

 **DANGER**

This symbol alerts you to a dangerous situation. Failure to avoid this situation will result in serious or fatal injury.

 **WARNING**

This symbol alerts you to a dangerous situation. Failure to avoid this situation can result in serious or fatal injury.

 **CAUTION**

This symbol alerts you to a dangerous situation. Failure to avoid this situation can result in minor or medium injury.

 **NOTICE**

This symbol contains information on procedures and other facts which do not result in personal injury.

Electrical symbols



Alternating current



Direct current and alternating current



Direct current



Ground connection

A grounded terminal which, as far as the operator is concerned, is grounded via a grounding system.

 **Protective earth (PE)**

Ground terminals that must be connected to ground prior to establishing any other connections.

The ground terminals are located on the interior and exterior of the device:

- Interior ground terminal: protective earth is connected to the mains supply.
- Exterior ground terminal: device is connected to the plant grounding system.

Tool symbols



Phillips head screwdriver



Flat blade screwdriver



Torx screwdriver



Allen key



Open-ended wrench

Symbols for certain types of information and graphics

 **Permitted**

Procedures, processes or actions that are permitted

 **Preferred**

Procedures, processes or actions that are preferred

 **Forbidden**

Procedures, processes or actions that are forbidden

 **Tip**

Indicates additional information



Reference to documentation



Reference to graphic



Notice or individual step to be observed

1., 2., 3.

Series of steps



Result of a step



Visual inspection



Operation via operating tool



Write-protected parameter

1, 2, 3, ...

Item numbers

A, B, C, ...

Views



Safety instructions

Observe the safety instructions contained in the associated Operating Instructions



Temperature resistance of the connection cables

Specifies the minimum value of the temperature resistance of the connection cables

Function and system design

Measuring principle

NMS8x is an intelligent tank gauge for measuring liquid levels with high precision. The system is based on the principle of gauging displacement.

A small displacer is accurately positioned in a liquid medium using a stepping motor. The displacer is then suspended on a measuring wire which is wound onto a finely grooved wire drum. NMS8x counts the rotations of the wire drum and to calculate the traveling distance of the wire and obtain the liquid level change.

The drum is driven via coupling magnets that are completely separated by the drum housing. Outer magnets are connected to the wire drum, with inner magnets connected to the drive motor. As the inner magnets turn, their magnetic attraction causes the outer magnets to turn, as well, causing the entire drum assembly to turn. The change of the apparent weight of the displacer on the wire creates torque on the outer magnets generating change of magnetic flux. These changes generated in the drum assembly are detected by a unique electromagnetic transducer on the inner magnets. The transducer transmits the weigh signal to a CPU using a non contact principle (patented). The drive motor is actuated to keep the weigh signal constant at set value defined by the operating command.

When the displacer is lowered and touches a liquid, the apparent weight of the displacer is reduced by liquid buoyancy force, which is measured by a temperature-compensated magnetic transducer. As a result, the torque in the magnetic coupling changes, and this is measured by six hall sensors. A signal indicating the weight of the displacer is sent to the motor control circuit. As the liquid levels rise and fall, the displacer position is adjusted by the drive motor. The rotation of the wire drum is continuously evaluated to determine the level value using a magnetic rotary encoder. In addition to gauging the level, NMS8x can measure the interfaces between up to three liquid phases, and the tank bottom, as well as spot and profile densities.

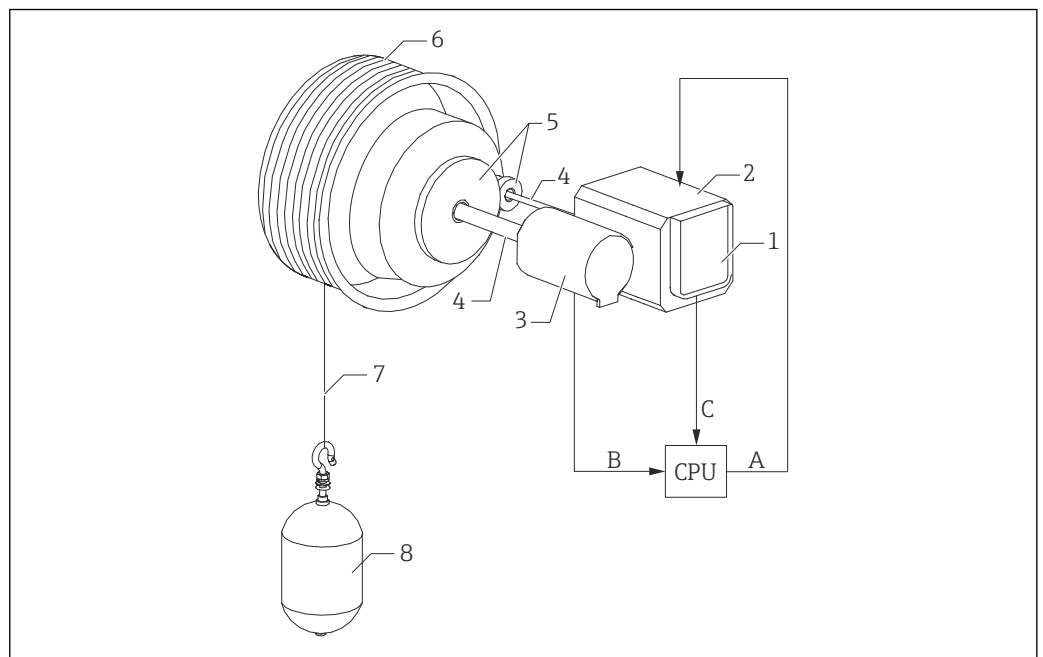

A0026724

1 Operating principle

- A Displacer position data
- B Weight data
- C Wire drum rotation data
- 1 Encoder
- 2 Motor
- 3 Rotary transformer
- 4 Shafts
- 5 Gears
- 6 Wire drum
- 7 Measuring wire
- 8 Displacer

Integration of tank sensors

In addition to measuring the level, interfaces, tank bottom, and density, the device can also be used to integrate of tank sensors into tank inventory systems. All measured and calculated system values can be displayed on the built-in display. They can be transferred to an inventory control system via a field communication protocol.

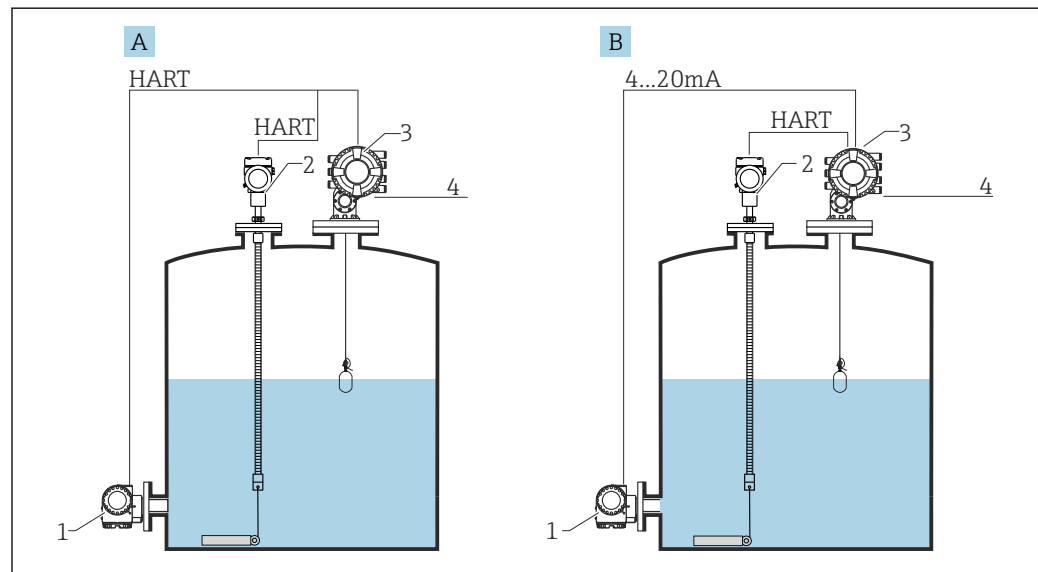

2 Measuring system for NMS80/NMS81

A HART multidrop mode

B HART and analog mode

1 Pressure transmitter

2 Average temperature transmitter (NMT81)

3 Proservo NMS8x

4 Field protocol transmits data to an inventory control system

Typical values measured by the sensors are:

- Level
- Spot temperature
- Average temperature
- Water level
- Pressure
- Secondary level value (for critical applications)

Major applications

The number of measuring functions and output options, as well as the compact design, enables NMS8x to be installed in a wide range of applications at minimal cost.

Petroleum industry

From oil production to storage at an oil depot, there exists an extensive need to measure and manage a wide variety of products. Remote tank gauging by NMS8x combined with an inventory management system is an ideal way to measure and manage tank contents.

Chemical industry

A wide choice of options for the wetted parts ensures chemical compatibility and long product life.

Power plant

Fuel oil levels are major applications where precise measurement is required to ensure safe operation.

Typical tank installation

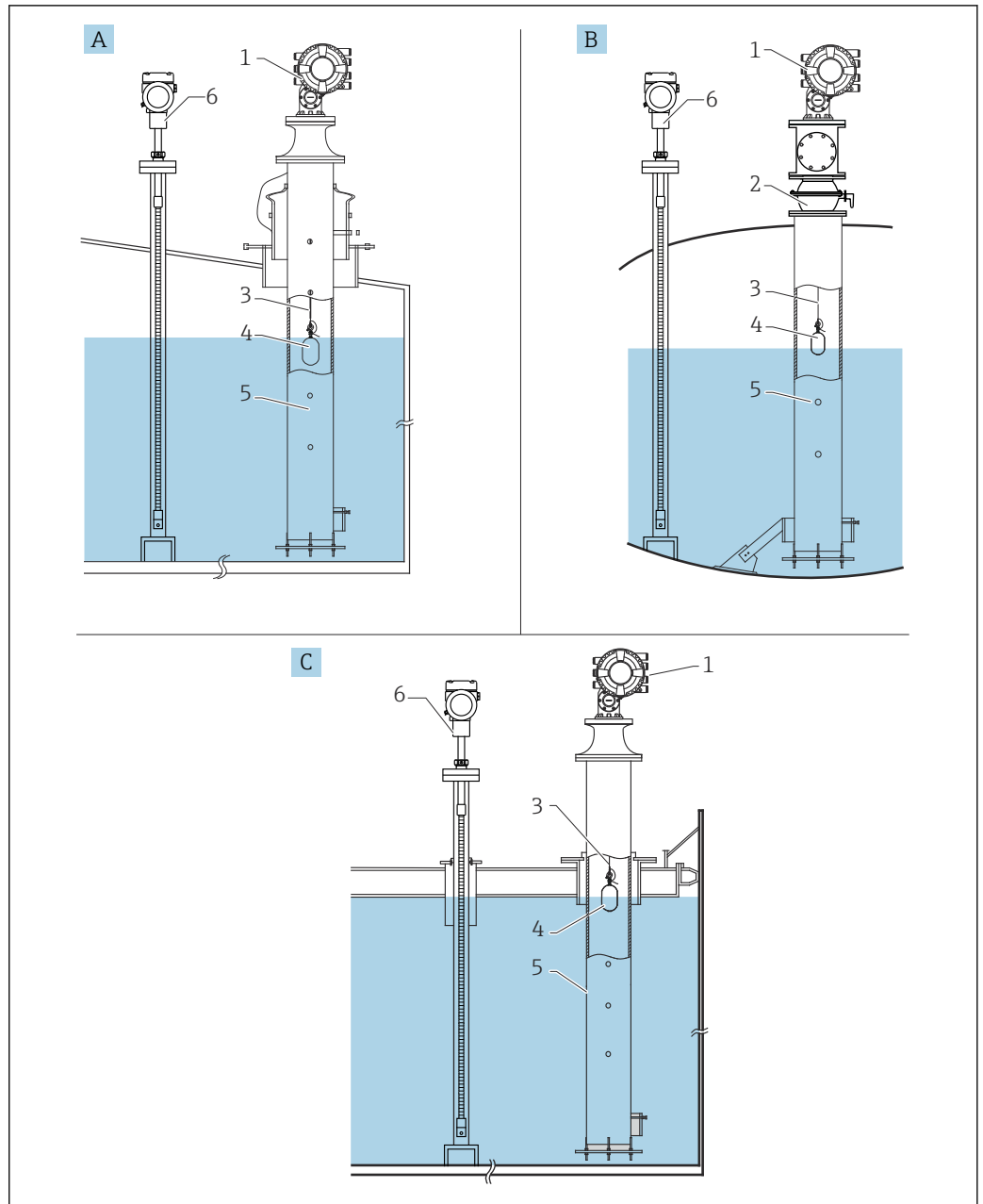

A0026725

3 Typical tank installation

- A Fixed roof tank
- B High pressure tank
- C Floating roof tank with stilling well
- 1 NMS8x
- 2 Ball valve
- 3 Measuring wire
- 4 Displacer
- 5 Stilling well
- 6 Prothermo NMT81

i When installing NMS8x to a floating roof tank, be sure to use a stilling well to protect the measuring wire. Otherwise the wire may break due to an external shock.

Application

NMS8x is primarily a highly accurate level measurement gauging instrument with the added ability to measure density. The following level measurements are supported: liquid surface level and interface level(s) between different liquids, as well as finding tank floor or datum plate. The following density measurements are supported: single-point (spot measurements), as well as profile measurements of all liquid(s) in a tank.

The choice of the most suitable displacer depends on the liquid conditions and measurement functions. These can be classified as follows:

- Continuous measurement value, e.g. level, interface
- One-time measurement value, e.g. spot density, tank profile, interface profile, manual profile

Measurement terminology

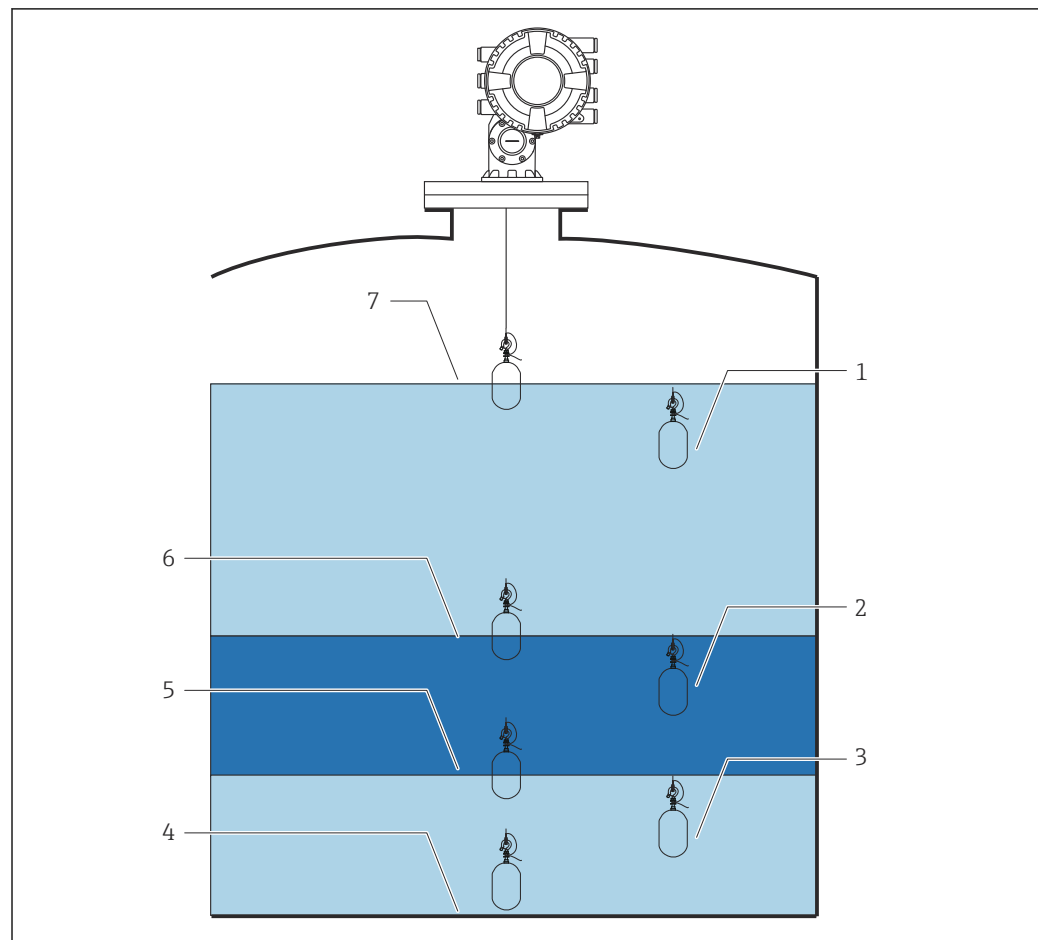

A0026727

4 NMS8x with standard level, I/F x 2, Tank bottom and spot density x 3 measurement

- 1 Upper density
- 2 Middle density
- 3 Lower density
- 4 Tank bottom
- 5 Lower I/F
- 6 Upper I/F
- 7 Level

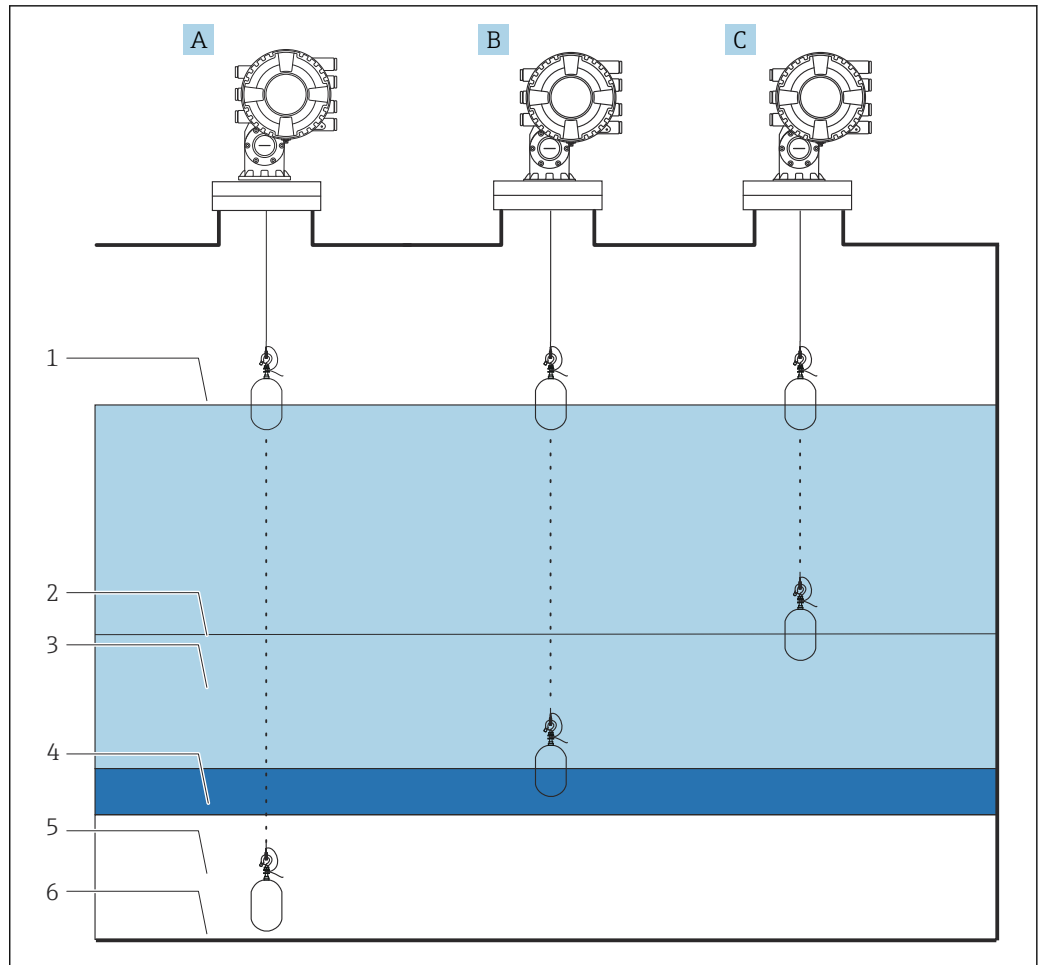

A0026728

5 Density Profile measurement

- A Tank profile: density profiling throughout tank
- B Interface profile: density profiling withing upper phase
- C Manual profile: density profiling from a specific position to level
- 1 Level
- 2 Manual profile level
- 3 Upper phase (oil)
- 4 Middle phase (emulsion)
- 5 Lower phase (water)
- 6 Tank bottom

Displacer selection guide

A wide variety of displacers are available to suit different application. Proper displacer selection ensures optimal performance and longevity. The following guidelines will assist you in selecting the most suitable displacer for your application.

Displacer types

The following NMS8x displacers are available.

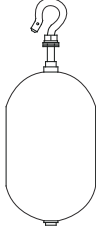
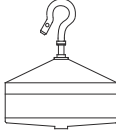
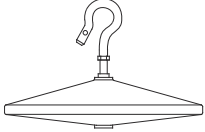
30 mm (1.18 in)	50 mm (1.97 in)	70 mm (2.76 in)	110 mm (4.33 in)
316L/PTFE	316L/AlloyC276/PTFE	316L	316L
			

Displacer dimensions

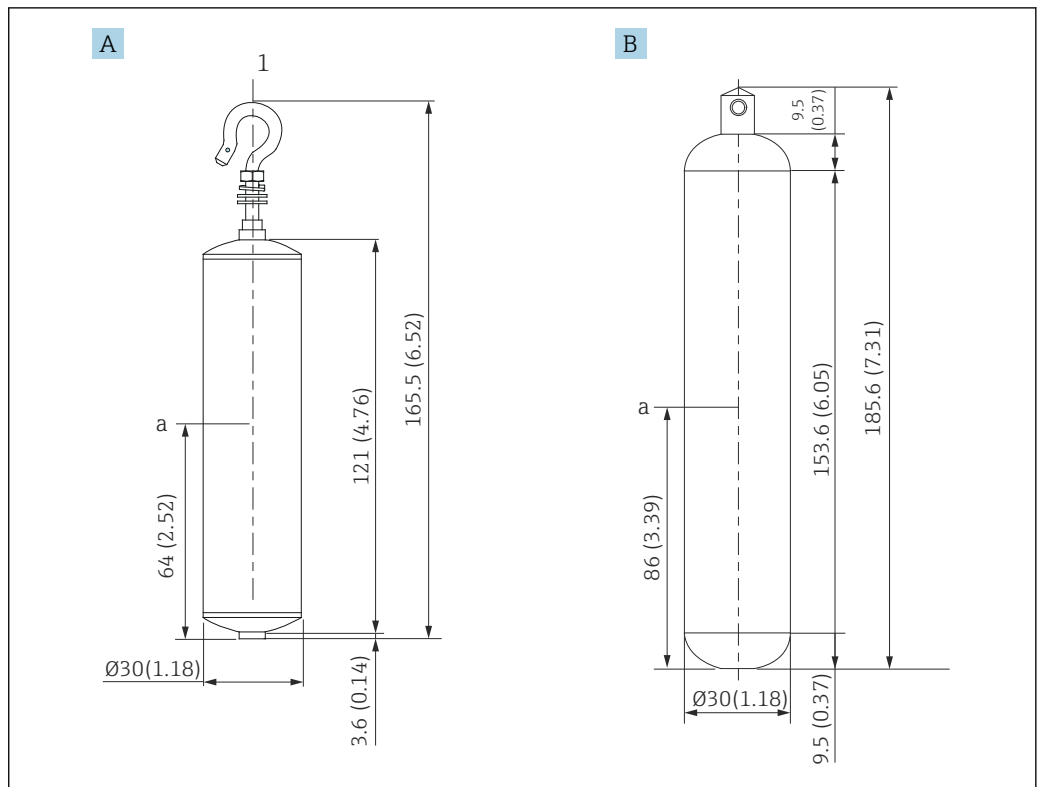

A0029579

- A Ø30 mm (1.18 in) 316L cylindrical displacer
- B Ø30 mm (1.18 in) PTFE cylindrical displacer
- a Immersion point

Item	Ø30 mm (1.18 in) 316L cylindrical displacer	Ø30 mm (1.18 in) PTFE cylindrical displacer
Weight (g)	261	250
Volume (ml)	84.3	118
Balance volume (ml)	41.7	59

i The weight, volume, and balance volume are individually determined by each displacer and also might vary depending on the values stated above.

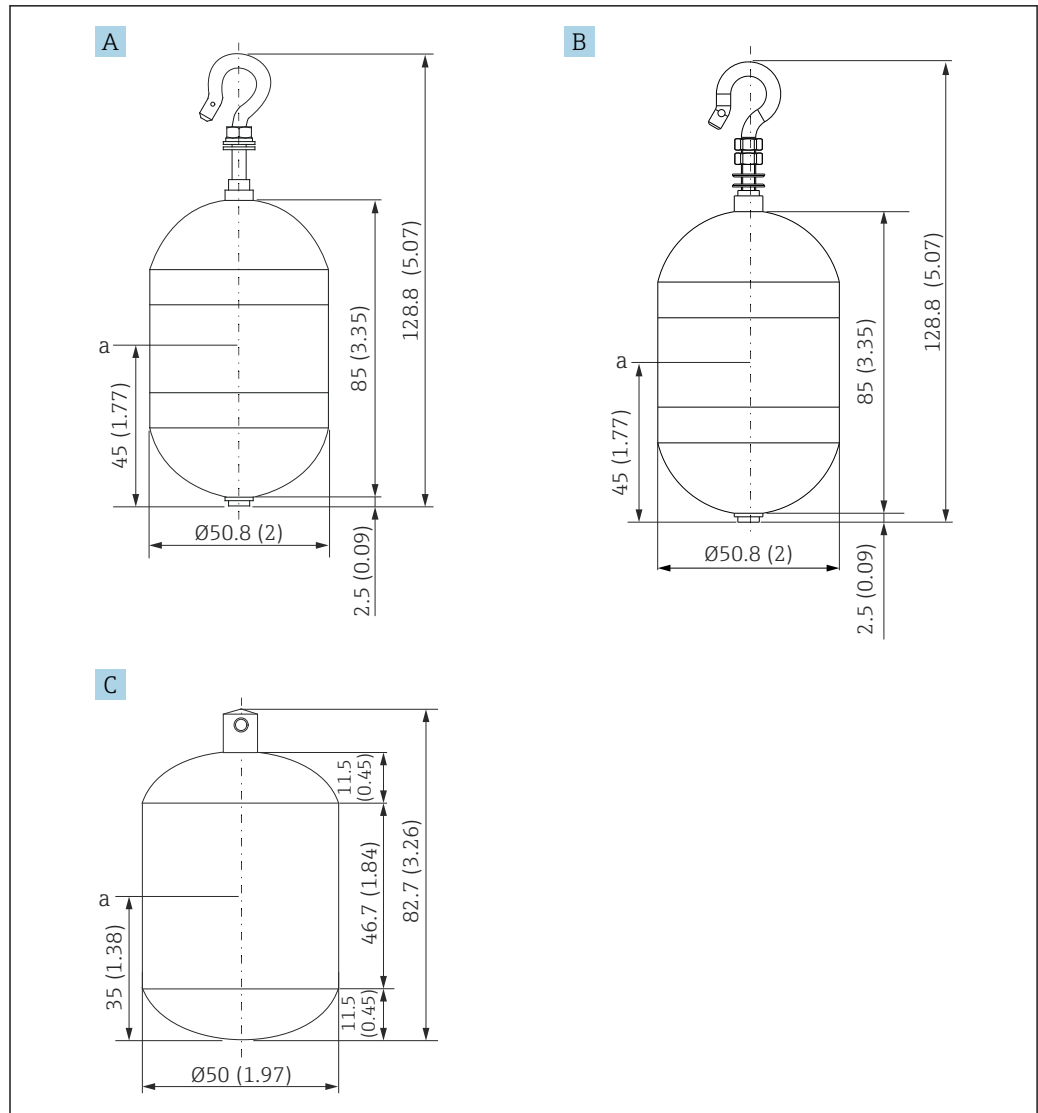

A0029580

- A $\varnothing 50$ mm (1.97 in) 316L cylindrical displacer
- B $\varnothing 50$ mm (1.97 in) AlloyC276 cylindrical displacer
- C $\varnothing 50$ mm (1.97 in) Conductive PTFE cylindrical displacer (Black)
- a Immersion point

Item	$\varnothing 50$ mm (1.97 in) 316L cylindrical displacer	$\varnothing 50$ mm (1.97 in) AlloyC276 cylindrical displacer	$\varnothing 50$ mm (1.97 in) PTFE cylindrical displacer
Weight (g)	253	253	250
Volume (ml)	143	143	118
Balance volume (ml)	70.7	70.7	59

i The weight, volume, and balance volume are individually determined by each displacer and also might vary depending on the values stated above.

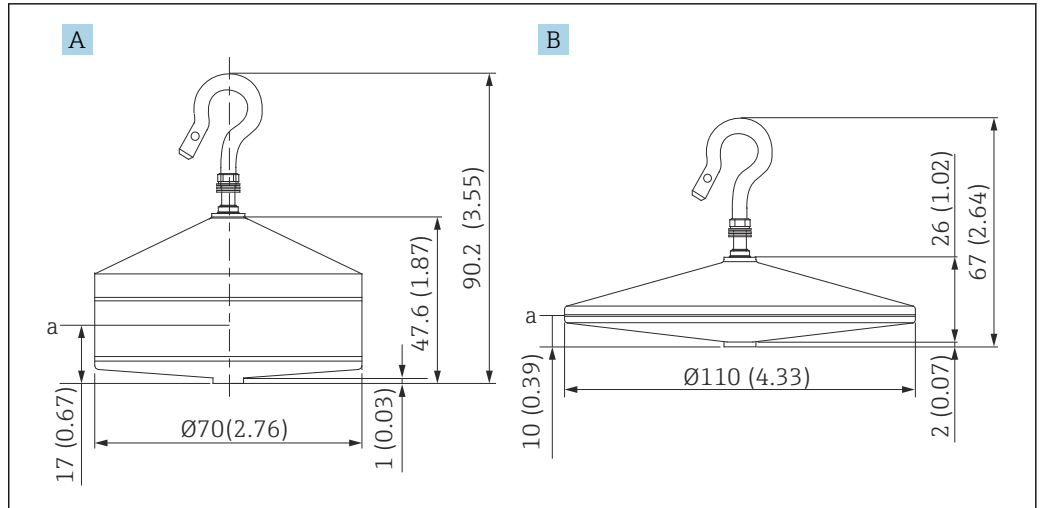

A0029582

A Ø70 mm (2.76 in) 316L conical displacer
 B Ø110 mm (4.33 in) 316L conical displacer
 a Immersion point

Item	Ø70 mm (2.76 in) 316L conical displacer	Ø110 mm (4.33 in) 316L conical displacer
Weight (g)	245	223
Volume (ml)	124	108
Balance volume (ml)	52.8	36.3

i The weight, volume, and balance volume are individually determined by each displacer and also might vary depending on the values stated above.

Recommended displacer by application

Application	Product level	Interface level	Density
Viscous liquid	50 mm (1.97 in) PTFE	Not Recommended	Not Recommended
Black oil (e.g. crude oil, heavy oil)	50 mm (1.97 in) 316L 50 mm (1.97 in) PTFE	50 mm (1.97 in) 316L 50 mm (1.97 in) PTFE	50 mm (1.97 in) 316L 50 mm (1.97 in) PTFE
White oil (e.g. gasoline, diesel, heating oil)	50 mm (1.97 in) or 70 mm (2.76 in) 316L	50 mm (1.97 in) or 70 mm (2.76 in) 316L	50 mm (1.97 in) or 70 mm (2.76 in) 316L
Liquefied gas, LPG/LNG	50 mm (1.97 in) or 70 mm (2.76 in) 316L	50 mm (1.97 in) or 70 mm (2.76 in) 316L	50 mm (1.97 in) or 70 mm (2.76 in) 316L
Corrosive liquid	50 mm (1.97 in) AlloyC276 50 mm (1.97 in) PTFE	50 mm (1.97 in) AlloyC276 50 mm (1.97 in) PTFE	50 mm (1.97 in) AlloyC276 50 mm (1.97 in) PTFE

Product level

In general, larger diameter displacers have better accuracy under similar conditions.

Interface level(s)

Cylindrical-shaped displacers, with rounded top and bottom, reduce resistance while moving through liquid(s). This provides smoother movement and faster interface measurements compared to flat-faced displacers, particularly in density profile measurements that span the full tank height.

i In order to move a displacer down through liquids, the displacer density (weight divided by volume) must be higher than the liquid density.

Tank bottom and datum plate level

70 mm (2.76 in) and 50 mm (1.97 in) displacers reduce resistance while moving through liquids. This provides smoother movement and faster interface measurements.

Density

Since the density is the calculated result of two measurements, a displacer with higher volume will usually yield the most accurate density measurement. In most cases we recommend our 50 mm (1.97 in) diameter displacer for density measurement.

For non-viscous applications (e.g. white oil, LPG/LNG), the 70 mm (2.76 in) displacer also works very well.

Level and density

When an application calls for equal emphasis on measuring both level and density, the 50 mm (1.97 in) and the 70 mm (2.76 in) diameter displacers will give the best all-around performance.

Custody transfer

The 50 mm (1.97 in) displacer or larger is the choice for requirements per NMI.

The 110 mm (4.33 in), conical 316L displacer is the choice for requirements per PTB.

Material compatibility

Displacers are available in three different standard materials. Material compatibility should be confirmed to ensure safe operation and optimal NMS8x performance.

316L

For NMS80 and NMS81, stainless steel is a highly versatile industrial material that provides good compatibility with a wide range of chemicals, including most white and black oils.

AlloyC276

This high-performance material is harder than 316L, and provides excellent resistance to many of the harshest corrosive chemical applications.

PTFE

One of the most well-known and versatile polymer materials, this high-performance material has one of the lowest friction coefficients. It provides excellent performance in viscous/sticky liquids, and also has excellent chemical resistance to a wide range of corrosives.

Process connection size

The process connection defines the tank process entry, and may affect the displacer size. The standard NMS8x process connections start at 3"/DN80 and fit most tank gauging applications. Accordingly, most applications can be covered with one of the 50mm or 70mm displacer options. Smaller diameter displacers are available when the process connection is smaller.



When the 110 mm (4.33 in) diameter custody transfer approval (PTB) displacer is selected, a separate calibration and maintenance chamber is recommended between the NMS8x and tank process connection.

Measuring system

- From single tank level measurement to the largest oil refinery applications, Endress+Hauser tank gauging devices are an integral part of tank farm management solutions. A wide variety of data output protocols are available for seamless integration into many commonly used systems.
- A primary example is Tankvision from Endress+Hauser. Tankvision is a scalable system offering local tank management for multiple loops via Modbus or V1 protocols. Accumulated data is available to DCS and other plant management systems via a Host Link.

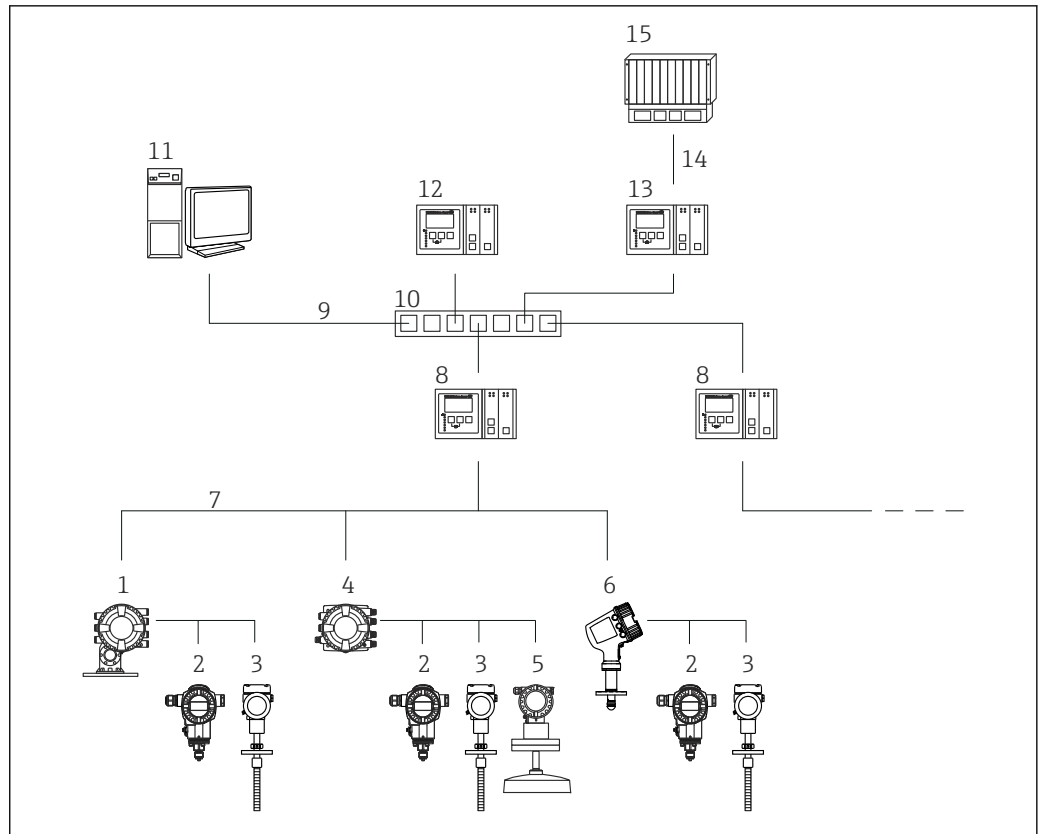

A0027700

6 Integration of tank gauging devices into an inventory management system (typical example)

- 1 Proservo NMS8x
- 2 Pressure transmitter (e.g. Cerabar)
- 3 Temperature transmitter (e.g. Prothermo)
- 4 Tankside Monitor NRF81
- 5 Micropilot S FMR5xx
- 6 Micropilot NMR8x
- 7 Field protocol (e.g. Modbus, V1)
- 8 Tankvision Tank Scanner NXA820
- 9 Ethernet
- 10 Ethernet switch
- 11 Internet Browser
- 12 Tankvision Data Concentrator NXA821
- 13 Tankvision Host Link NXA822
- 14 Modbus
- 15 DCS or PLC

Input/output

Level measurement

Measured variable



Proservo is primarily a highly accurate level measurement gauging instrument, with the added ability to measure interfaces and densities. The following level measurements are supported: liquid surface level and interface level(s) between different liquids, as well as finding tank bottom or datum plate. The following density measurements are supported: single-point (called "spot" measurements), as well as profile measurements of all liquid(s) in a tank.

Measuring range

- Level and interface: Max.36 m (118 ft)(longer range is possible as special product)
- Density: 0.430 to 2.000 g/cm³

The level and interface measuring range depend on the measuring wire and material compatibility to measured medium. Measuring wires are available in three different standard materials. Material compatibility should be confirmed to ensure safe operation and optimal measuring performance.

Measuring range	Material
16 m (52.49 ft)	PFA > 316L
22 m (73.33 ft)	AlloyC276
28 m (93.33 ft), 36 m (118 ft)	316L

-  For devices with custody calibration (10 points) with option ITA or ITC of ordering feature 150 "Accuracy, Weight + Measure Approval": Maximum measuring range : 40 m (131 ft)
-  If the application exceeds the range listed above, contact Endress+Hauser for technically special products / solutions.

HART Ex ia/IS active input

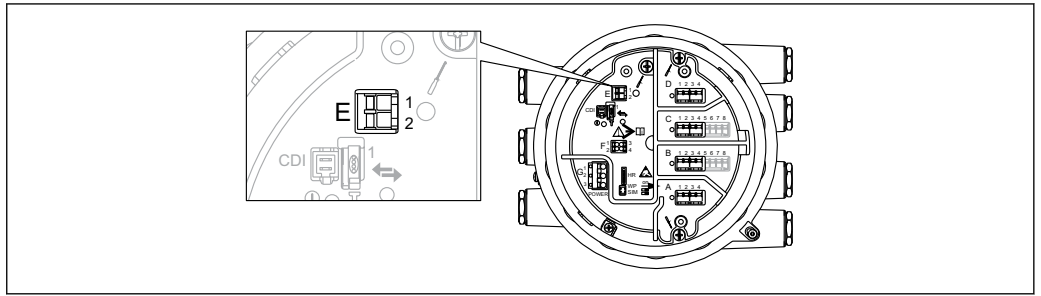

A0027364

 7 HART Ex ia/IS active input

E1 HART +

E2 HART -

The device has a HART Ex ia/IS active input. Additional features are provided if the following Endress+Hauser devices are connected:

Prothermo NMT

The measured level is transmitted to the Prothermo. Prothermo uses this level to calculate the average temperature of the product.

Technical data

- Transmitter power supply voltage
23.0 V - $380 \Omega \cdot I_{load}$
- Maximum load
500 Ω including signal line
- Maximum current of all connected devices
24 mA



The HART Ex ia/IS active input is available by default. It needs not to be chosen explicitly when ordering a device.

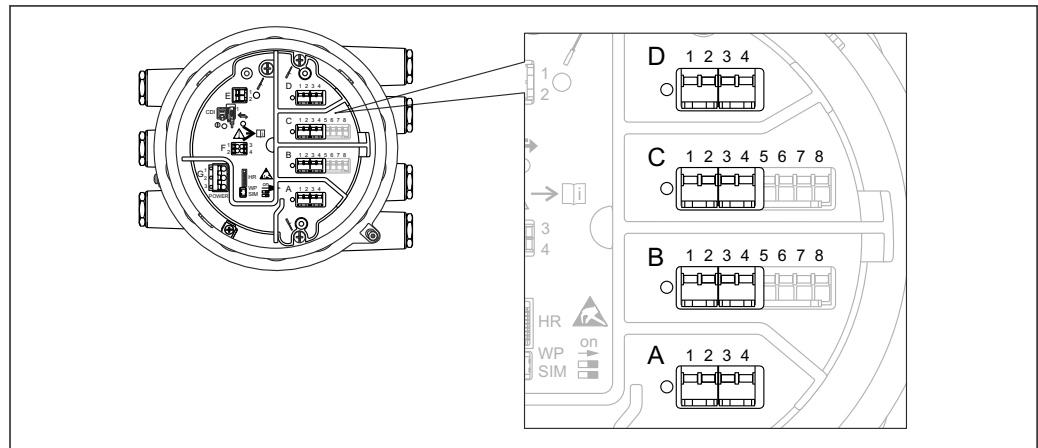

A0027363

8 Position of the I/O modules in the terminal compartment

The terminal compartment contains up to four I/O modules, depending on the order code.

- Modules with four terminals can be in any of these slots.
- Modules with eight terminals can be in slot B or C.

i The exact assignment of the modules to the slots is dependent on the device version. For a detailed description refer to the Operating Instructions of the device in question.

- i** The following restrictions apply when selecting the modules:
- The device may contain a maximum of four I/O modules.
 - A maximum of two I/O modules with 8 terminals is possible.

Ordering feature 040: "Primary Output"

NMx8x - xxxx <u>XX</u> xx xx ... 040			
O ¹⁾	N ²⁾	T ³⁾	S ⁴⁾
Modbus RS485 ⁵⁾			
A1	1	4	→ 21
V1 ⁵⁾			
B1	1	4	→ 22
4-20mA HART Ex d/XP ⁵⁾			
E1	1	8	→ 24
4-20mA HART Ex i/IS ⁵⁾			
H1	1	8	→ 24
WM550 ⁵⁾			
C1	1	4	→ 23

- 1) Option
- 2) Number of I/O modules
- 3) Number of terminals
- 4) Technical data
- 5) Type of I/O module

Ordering feature 050: "Secondary I/O Analogue"

NMx8x - xxxx xx <u>XX</u> xx ... 050	
---	--









Ordering feature 050: "Secondary I/O Analogue"



- Type of I/O module:
1 x "Ex d/XP 4-20mA HART + RTD input"
 - Option
A1
 - Number of I/O modules
1
 - Number of terminals
1 x 8
 - Technical data → ⓘ 24
- Type of I/O module:
2 x "Ex d/XP 4-20mA HART + RTD input"
 - Option
A2
 - Number of I/O modules
2
 - Number of terminals
2 x 8
 - Technical data → ⓘ 24
- Type of I/O module:
1 x "Ex i/IS 4-20mA HART+ RTD input"
 - Option
B1
 - Number of I/O modules
1
 - Number of terminals
1 x 8
 - Technical data → ⓘ 24
- Type of I/O module:
2 x "Ex i/IS 4-20mA HART+ RTD input"
 - Option
B2
 - Number of I/O modules
2
 - Number of terminals
2 x 8
 - Technical data → ⓘ 24
- Type of I/O module:
1 x "Ex i/IS 4-20mA HART + RTD input"
1 x "Ex d/XP 4-20mA HART + RTD input"
 - Option
C2
 - Number of I/O modules
2
 - Number of terminals
2 x 8
 - Technical data → ⓘ 24
- Type of I/O module:
none
 - Option
X0
 - Number of I/O modules
0
 - Number of terminals
0
 - Technical data -

Ordering feature 060: "Secondary I/O Digital Ex d/XP"

NMx8x - xxxx xx xx <u>XX</u> ... 060

Ordering feature 060: "Secondary I/O Digital Ex d/XP"

- Type of I/O module:
1 x "2x relay + 2x discrete I/O"
 - Option
A1
 - Number of I/O modules
1
 - Number of terminals
1 x 4
 - Technical data →  26
- Type of I/O module:
2 x "2x relay + 2x discrete I/O"
 - Option
A2
 - Number of I/O modules
2
 - Number of terminals
2 x 4
 - Technical data →  26
- Type of I/O module:
3 x "2x relay + 2x discrete I/O"
 - Option
A3
 - Number of I/O modules
3
 - Number of terminals
3 x 4
 - Technical data →  26
- Type of I/O module:
1x "Modbus RS485"
 - Option
B1
 - Number of I/O modules
1
 - Number of terminals
3 x 4
 - Technical data →  21
- Type of I/O module:
1x "2x relay + 2x discrete I/O"
 - Option
B2
 - Number of I/O modules
2
 - Number of terminals
2 x 4
 - Technical data
→  21
→  26
- Type of I/O module:
1x "Modbus RS485"
2 x "2x relay + 2x discrete I/O"
 - Option
B3
 - Number of I/O modules
3
 - Number of terminals
3 x 4
 - Technical data
→  21
→  26

- Type of I/O module:
1 x "WM550"
 - Option
E1
 - Number of I/O modules
1
 - Number of terminals
1 x 4
 - Technical data →  23
- Type of I/O module:
1 x "WM550"
1 x "2x relay + 2x discrete I/O"
 - Option
E2
 - Number of I/O modules
2
 - Number of terminals
2 x 4
 - Technical data →  23
- Type of I/O module:
1 x "WM550"
2 x "2x relay + 2x discrete I/O"
 - Option
E3
 - Number of I/O modules
3
 - Number of terminals
3 x 4
 - Technical data →  23
- Type of I/O module:
none
 - Option
X0
 - Number of I/O modules
0
 - Number of terminals
0
 - Technical data -

"Modbus RS485": Technical data

Number of units
Maximum 15 instruments per loop

Baud rate: Selectable

- 600 bit/s
- 1 200 bit/s
- 2 400 bit/s
- 4 800 bit/s
- 9 600 bit/s
- 19 200 bit/s

Parity: Selectable

- Odd
- Even
- None

Cable
3-wire, with screening

The screening must be connected inside the housing

Termination resistors

To be set as required in specific environments

Topology

Serial bus

Transmission distance

Maximum 1 200 m (3 900 ft)

Instrument address

Each transmitter has an individual bus address configured in the software of the transmitter

Isolation

Bus inputs are electrically isolated from the other electronics

Error on alarm

Error message classified according to NAMUR NE 107

"V1": Technical data

Number of units

Maximum 10 instruments per loop

Baud rate: Selectable

3 300 bit/s

Cable

- 2-wire twisted pair, screening recommended

- 2-wire, unshielded

Termination resistors

Not required

Topology

- Serial bus

- Tree structure

Transmission distance

Maximum 6 000 m (19 700 ft)

Instrument address

Each transmitter has an individual bus address configured in the software of the transmitter

Isolation

Serial communication circuit isolated from other circuits

Error on alarm

Error message classified according to NAMUR NE 107

WM550: Technical data

Number of units

Maximum 15 ¹⁾ instruments per loop

Baud rate: Selectable

- 600 bit/s
- 1 200 bit/s
- 2 400 bit/s
- 4 800 bit/s

Cable

- 2-wire twisted pair, unshielded (recommended)
- 2-wire, shielded or unshielded

Topology

Current loop or 2 redundant current loops (requires 2 I/O modules WM550)

Transmission distance

Maximum 7 000 m (22 967 ft)

Instrument address

Each transmitter has an individual bus address configured in the software of the transmitter

Isolation

Serial communication circuit isolated from other circuits

Error on alarm

Error message classified according to NAMUR NE 107

1) The maximum number of devices depends on the maximum output voltage of the master and the voltage drop of slaves. For NXA820 with Nxx8x devices, a maximum number of 12 devices is guaranteed

"4-20mA HART" I/O module (Ex d/XP or Ex i/IS): Technical data**General data**

Number of units

Maximum 6 instruments per loop

Baud rate: Selectable

1 200 bit/s

Cable

- 2-wire twisted pair, screened
- Core cross section: 0.2 to 2.5 mm² (24 to 13 AWG)

Topology

- Serial bus
- Tree structure

Transmission distance

Maximum 1 200 m (3 900 ft)

Instrument address

Each transmitter on a signal loop has an individual bus address. This is defined within the transmitter software and / or auxiliary configuration environment such as host system or Field Communicator 475.

Isolation

Bus inputs are electrically isolated from the other electronics

Input data

Input operating modes

- 4..20mA input (1 external device)
- HART master+4..20mA input (1 external device)
- HART master (up to 6 external devices)

Internal load (to ground)

400 Ω

Measuring range

0 to 26 mA

Accuracy

±15 µA (after linearization and calibration)

Connection of a Prothermo NMT

The measured level is transmitted to the Prothermo. Prothermo uses this level to calculate the average temperature of the product.

Connection of a RTD temperature probe

2-, 3- or 4-wire connection

Output data

Output operating modes

- 4..20mA output
- HART slave +4..20mA output

Output current

3 to 24 mA

Accuracy

±15 µA (after linearization and calibration)

Error on alarm

HART error message classified according to NAMUR NE 107

Data for passive usage (input or output)

- Minimum terminal voltage
10.4 V²⁾
- Maximum terminal voltage
29 V²⁾

2) Observing these values is mandatory in order to ensure correct measured value information.

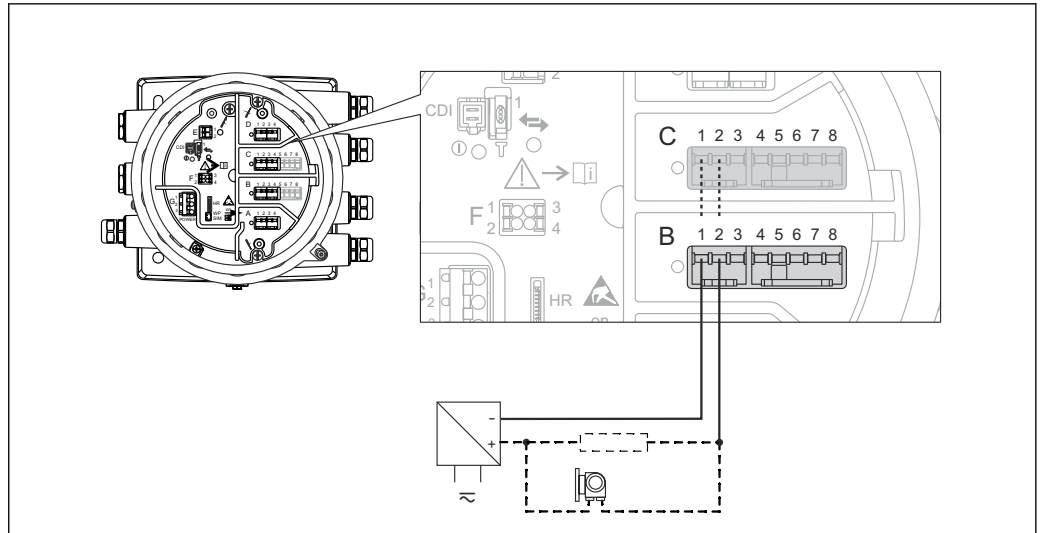

A0033030

9 Passive input or output: Use terminals 1 and 2

Data for active usage (input or output)

- Transmitter power supply voltage (Ex d/XP)
18.5 V - $360 \Omega \cdot I_{load}$
- Transmitter power supply voltage (Ex i/IS)
20.0 V - $360 \Omega \cdot I_{load}$
- Output load
max. 500 Ω including signal line ³⁾

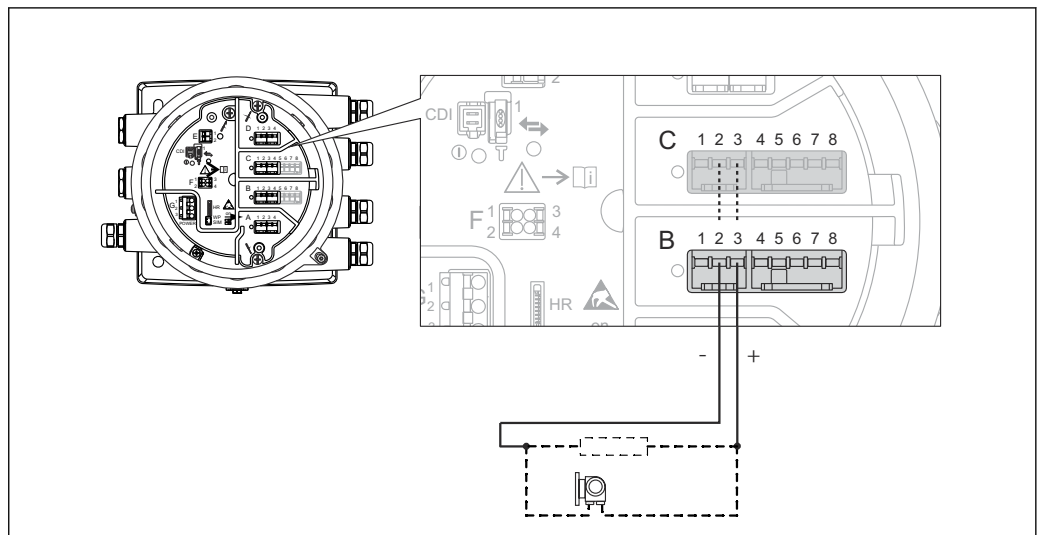

A0033031

10 Active input or output: Use terminals 2 and 3

3) Observing this value is mandatory in order to ensure correct measured value information.

"Digital I/O module": Technical data**Output**

- Relay switching power for resistive load
 - 30 V_{DC} @ 2 A
 - 250 V_{DC} @ 0.1 A
 - 250 V_{AC} @ 2 A
- Relay type
 - normally open;
 - can be set to "normally closed" by a software option ⁴⁾

Input

- Maximum pick-up voltage
 - 250 V_{AC}
 - 250 V_{DC}
- Minimum pick-up voltage
 - 25 V_{AC}
 - 5 V_{DC}
- Current consumption at maximum voltage
 - ≤ 1 mA (DC)
 - ≤ 2 mA (AC)

4) In case of a power supply failure, the switching state is always "open", irrespective of the selected software option.

Power supply

Terminal assignment

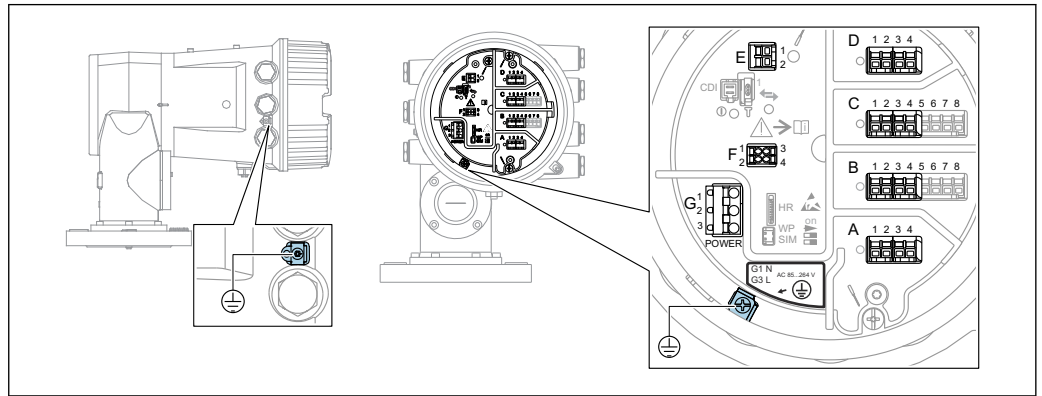

11 Terminal compartment (typical example) and ground terminals

i Housing thread

The threads of the electronics and connection compartment can be coated with an anti-friction coating.

The following applies for all housing materials:

✗ Do not lubricate the housing threads.

Terminal area A/B/C/D (slots for I/O modules)

Module: Up to four I/O modules, depending on the order code

- Modules with four terminals can be in any of these slots.
- Modules with eight terminals can be in slot B or C.



The exact assignment of the modules to the slots is dependent on the device version. For a detailed description refer to the Operating Instructions of the device in question.

Terminal area E

Module: HART Ex i/IS interface

- E1: H+
- E2: H-

Terminal area F

Remote display

- F1: V_{CC} (connect to terminal 81 of the remote display)
- F2: Signal B (connect to terminal 84 of the remote display)
- F3: Signal A (connect to terminal 83 of the remote display)
- F4: Gnd (connect to terminal 82 of the remote display)

Terminal area G (for High voltage AC power supply and Low voltage AC power supply)

- G1: N
- G2: not connected
- G3: L

Terminal area G (for Low voltage DC power supply)

- G1: L-
- G2: not connected
- G3: L+

Terminal area: Protective ground

Module: Protective ground connection (M4 screw)



12 Terminal area: Protective ground

Remote display and operating module DKX001

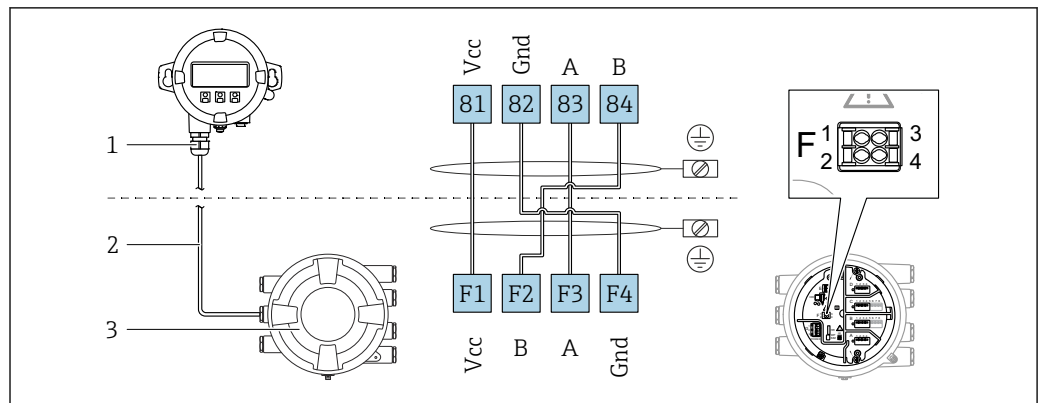

13 Connection of the remote display and operating module DKX001 to the Tank Gauging device (NMR8x, NMS8x or NRF8x)

- 1 Remote display and operating module
- 2 Connecting cable
- 3 Tank Gauging device (NMR8x, NMS8x or NRF8x)

i The remote display and operating module DKX001 is available as an accessory. For details refer to SD01763D.

- i**
 - The measured value is indicated on the DKX001 and on the local display and operating module simultaneously.
 - The operating menu cannot be accessed on both modules at the same time. If the operating menu is entered in one of these modules, the other module is automatically locked. This locking remains active until the menu is closed in the first module (back to measured value display).

Supply voltage

High voltage AC power supply:

Operational value:
 $100 \text{ to } 240 \text{ V}_{AC} (-15\% + 10\%) = 85 \text{ to } 264 \text{ V}_{AC}, 50/60 \text{ Hz}$

Low voltage AC power supply:

Operational value:
 $65 \text{ V}_{AC} (-20\% + 15\%) = 52 \text{ to } 75 \text{ V}_{AC}, 50/60 \text{ Hz}$

Low voltage DC power supply:

Operational value:
 $24 \text{ to } 55 \text{ V}_{DC} (-20\% + 15\%) = 19 \text{ to } 64 \text{ V}_{DC}$

Power consumption

Maximum power varies depending on the configuration of the modules. The value shows maximum apparent power, select the applicable cables accordingly. The actual consumed effective power is 12 W.

High voltage AC power supply:

28.8 VA

Low voltage AC power supply:

21.6 VA

Low voltage DC power supply:

13.4 W

Sources for gauge commands

Gauge commands can be sent via various sources.

- Displays or CDI (e.g. FieldCare)
- Digital input (e.g. switch)
- Fieldbus (Modbus, V1, HART)

The last received gauge command via any sources will be executed as usual.

i During calibration, gauge commands are not accepted from any sources.

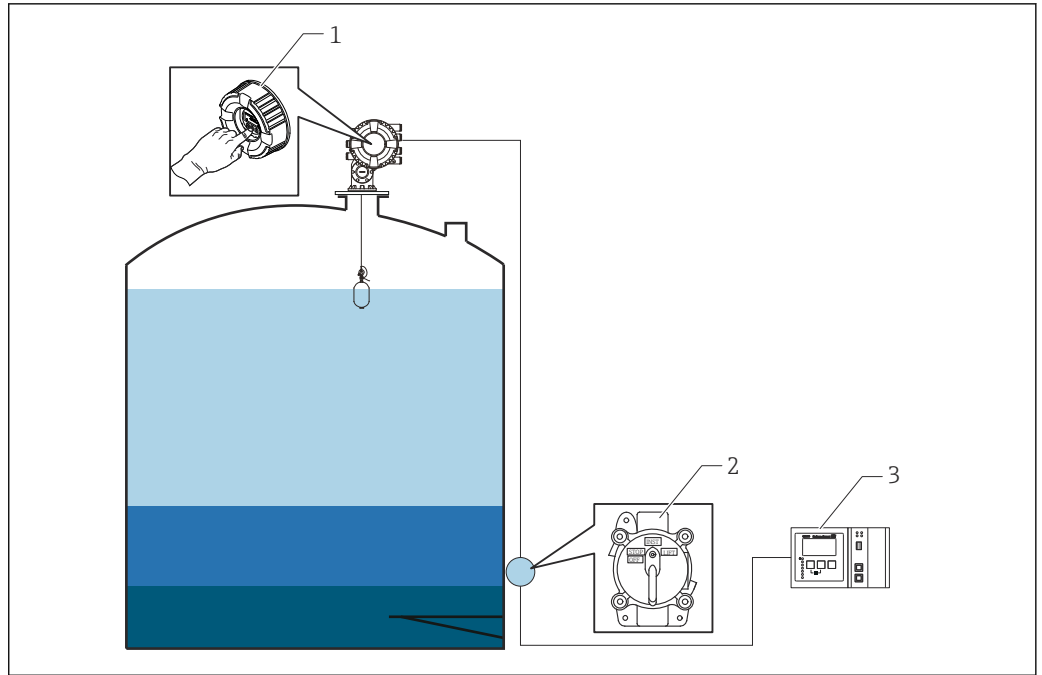

A0029538

- 1 Display operation
- 2 Digital input (e.g. switch)
- 3 Tankvision

Gauge command priorities

The priority of the gauge command for NMS8x is very simple. The last received gauge command via any sources will be executed to take of the former gauge command. However the priority varies depending on the devices. When replacing the device with the NMS8x, check the priorities shown below.

NOTICE

Undesired gauge command will be executed.

If the setting is not changed, an undesired gauge command will be executed (e.g. Level command via Fieldbus would overwrite Stop command for maintenance.).

- ▶ If the system has been automatically or semi-automatically programmed for operation, maintenance or other purposes, the setting should be changed corresponding to use.

Proservo NMS8x

By display		From digital input		From Fieldbus	
Command	Priority	Command	Priority	Command	Priority
Level	1	Level	1	Level	1
Interface	1	Interface	1	Interface	1
Tank bottom	1	Tank bottom	1	Tank bottom	1
Spot density	1	Spot density	1	Spot density	1
Profile density	1	Profile density	1	Profile density	1
Up	1	Up	1	Up	1
Stop	1	Stop	1	Stop	1

Proservo NMS5/NMS7

By display		From NRF560		From digital input		From Fieldbus	
Command	Priority	Command	Priority	Command	Priority	Command	Priority
Level	4	Level	4	Level	4	Level	4
Interface	2	Interface	3	Interface	1	Interface	4
Tank bottom	2	Tank bottom	3	N/A	N/A	Tank bottom	4
Spot density	2	Spot density	3	N/A	N/A	Spot density	4
Profile density	2	Profile density	3	N/A	N/A	Profile density	4
Up	2	Up	3	Up	1	Up	4
Stop	2	Stop	3	Stop	1	Stop	4

Servo level gauge TGM5

By display		From NRF560		From DRM9700		From digital input		From Fieldbus	
Command	Priority	Command	Priority	Command	Priority	Command	Priority	Command	Priority
Level	4	Level	4	Level	4	Level	4	Level	4
Interface	2	Interface	3	N/A	N/A	N/A	N/A	Interface	4
Tank bottom	2	Tank bottom	3	N/A	N/A	N/A	N/A	Tank bottom	4
Spot density	2	Spot density	3	N/A	N/A	N/A	N/A	Spot density	4
Profile density	2	Profile density	3	N/A	N/A	N/A	N/A	Profile density	4
Up	2	Up	3	Up	1	Up	1	Up	4
Stop	2	Stop	3	N/A	N/A	Stop	1	Stop	4

Servo level gauge TGM4000

By display		From DRM9700		From digital input		From Fieldbus	
Command	Priority	Command	Priority	Command	Priority	Command	Priority
Level	4	Level	4	Level	4	Level	4
Interface	2	Interface	1	N/A	N/A	Interface	4
Tank bottom	2	N/A	N/A	N/A	N/A	Tank bottom	4
Spot density	2	N/A	N/A	N/A	N/A	Spot density	4
Profile density	2	N/A	N/A	N/A	N/A	Profile density	4
Up	2	Up	1	Up	1	Up	4
Stop	2	Stop	N/A	Stop	1	Stop	4

Cable entries

Ordering feature 090 "Electrical Connection" ¹⁾	Cable entries (with blind plugs) ²⁾
A	7 x thread M20
B	7 x thread M25
C	7 x thread G1/2
D	7 x thread G3/4
E	7 x thread NPT1/2
F	7 x thread NPT3/4

- 1) Position 090 of the order code, e.g. NMx8x-xxxxxxxxxxxxxA...
- 2) The entries NOT having I/O modules inside will be directly assembled with 316L blind plugs without adapters. For details of module positions, refer to the chapter for "Slots for I/O modules" in Operating Instructions.

 For the following devices with JPN Ex approval, cable glands are attached to the device (see position 010 of the order code). These cable glands must be used.
Proservo NMS80-JC...

Cable specification

Terminals

Wire cross section 0.2 to 2.5 mm² (24 to 13 AWG)

Use for terminals with function: Signal and power supply

- Spring terminals (NMx8x-xx1...)
- Screw terminals (NMx8x-xx2...)

Wire cross section max. 2.5 mm² (13 AWG)

Use for terminals with function: Ground terminal in the terminal compartment

Wire cross section max. 4 mm² (11 AWG)

Use for terminals with function: Ground terminal at the housing

Power supply line

Standard device cable is sufficient for the power line.

HART communication line

- Standard device cable is sufficient if only the analog signal is used.
- Shielded cable is recommended if using the HART protocol. Observe the grounding concept of the plant.

Modbus communication line

- Observe the cable conditions from the TIA-485-A, Telecommunications Industry Association.
- Additional conditions: Use shielded cable.

V1 communication line

- 2-wire twisted pair, screened or unshielded cable
- Resistance in one cable: ≤ 120 Ω
- Capacitance between lines: ≤ 0.3 μF

WM550 communication line

- 2-wire twisted pair, unshielded cable
- Cross section minimum 0.5 mm² (20 AWG)
- Maximum total cable resistance: ≤ 250 Ω
- Cable with low capacitance

Overvoltage protection

On the communication and power lines; according to IEC 60060-1 /DIN 60079-14:
10 kA, 8/20 μs, 10 pulses according to IEC 60060-1 / DIN 60079-14

Overvoltage category

Overvoltage category II

Pollution degree

Pollution degree 2

Performance characteristics

Reference operating conditions According to OIML R85

Measured value resolution	Level and interface	≤ 0.1 mm (0.004 in)
	Density	≤ 0.001 g/cm ³

Maximum measured error	Level	±0.4 mm (±0.016 in)	Reference condition Accuracy of NMI approved calibration rig at Endress +Hauser Yamanashi according to the combination of the order code is as per the table below.
	Interface	±2 mm (±0.08 in)	Reference condition <ul style="list-style-type: none"> Standard displacer 70 mm (2.76 in) Density difference 0.2 g/cm₃ or more (min. detectable density difference for interface measurement is 0.1 g/cm₃) Max. performance selected in feat.150
	Tank bottom	±2 mm (±0.08 in)	Reference condition <ul style="list-style-type: none"> Standard displacer 70 mm (2.76 in) Flat datum plate or flat tank bottom Max. performance selected in feat.150
	Density	±0.003 g/cm ³	Reference condition <ul style="list-style-type: none"> Standard displacer 50 mm (1.97 in) or 70 mm (2.76 in) Density calibration (offset) Max. performance selected in feat.150

The following values are valid for a level measurement distance up to 40 m (133.33 ft).

Ordering feature 150	Weight and measure approval	Displacer (ordering feature 120)			
		1AA, 2AA	1AC, 2AC, 3AC, 4AC, 5AC	1BE, 4AE	1BJ
		Ø30 mm (1.18 in)	Ø50 mm (1.97 in)	Ø70 mm (2.76 in)	Ø110 mm (4.33 in)
Accuracy					
ICR	Standard version, w/o calibration certificate	±2.5 mm (±0.1 in)	±1 mm (±0.04 in)	±1 mm (±0.04 in)	±1 mm (±0.04 in)
ICW	Standard version, 3-point calibration certificate	±2.5 mm (±0.1 in)	±1 mm (±0.04 in)	±1 mm (±0.04 in)	±1 mm (±0.04 in)
ICX	Standard version, 5-point calibration certificate	±2.5 mm (±0.1 in)	±1 mm (±0.04 in)	±1 mm (±0.04 in)	±1 mm (±0.04 in)
ITA	Maximum performance, 10-point calibration certificate	N/A	±0.6 mm (±0.024 in)	±0.4 mm (±0.016 in)	±0.4 mm (±0.016 in)
ITC	Standard version, 10-point calibration certificate	N/A	±1 mm (±0.04 in)	±1 mm (±0.04 in)	±1 mm (±0.04 in)
LTA	Maximum Performance, LNE type approval acc. to OIML R85, API 3.1B, ISO4266, factory calib. certificate	N/A	±0.6 mm (±0.024 in)	±0.4 mm (±0.016 in)	±0.4 mm (±0.016 in)
LTC	Custody transfer, LNE type approval acc. to OIML R85, API 3.1B, ISO4266, factory calib. certificate	N/A	±1 mm (±0.04 in)	±1 mm (±0.04 in)	±1 mm (±0.04 in)

Ordering feature 150	Weight and measure approval	Displacer (ordering feature 120)			
		1AA, 2AA	1AC, 2AC, 3AC, 4AC, 5AC	1BE, 4AE	1BJ
		Ø30 mm (1.18 in)	Ø50 mm (1.97 in)	Ø70 mm (2.76 in)	Ø110 mm (4.33 in)
Accuracy					
NTA	Maximum performance, NMi type approval acc. OIML R85, API 3.1B, ISO 4266, factory calibration certificate	N/A	±0.6 mm (±0.024 in)	±0.4 mm (±0.016 in)	±0.4 mm (±0.016 in)
NTC	Custody transfer type approval acc. NMi OIML R85, API 3.1B, ISO4266, factory calibration certificate	N/A	±1 mm (±0.04 in)	±1 mm (±0.04 in)	±1 mm (±0.04 in)
PTA	Maximum performance, PTB type approval factory calibration certificate	N/A	N/A	±0.4 mm (±0.016 in)	±0.4 mm (±0.016 in)
PTC	Custody transfer type approval per PTB, factory calibration certificate	N/A	N/A	±1 mm (±0.04 in)	±1 mm (±0.04 in)

Hysteresis Within the specified accuracy (+/- 1 mm (0.039 in)) according to OIML R85 (2008)
It can be reduced by non hysteresis measurement mode.

Repeatability 0.1 mm (0.004 in)

Linearity Within maximum measured error

Long-term drift Within the specified error of measurement

Influence of ambient temperature Within the specified accuracy according to OIML R85 (2008)

Influence of medium temperature None (Displacer principle is not influenced by medium temperature.)

Influence of medium pressure No influence of medium pressure to the measuring principle.







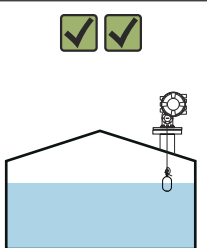
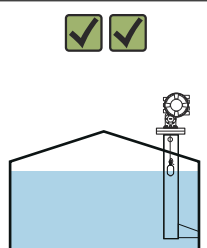
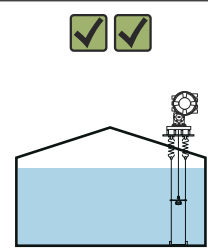

Effect of gas phase No effect of gas phase to the measuring principle.

Installation

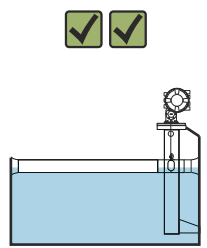
Requirements

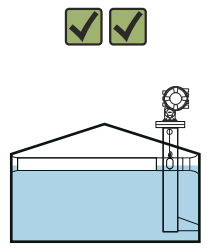
Type of tanks

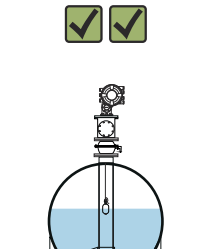
Depending on the type of tank and application, different installation procedures are recommended for NMS8x.

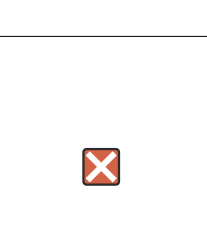
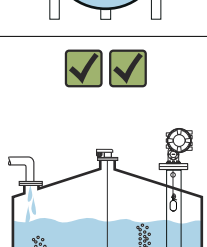
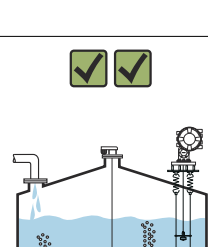
Type of tanks	Without guide system	With stilling well	With guide wires
Fixed roof tank			
Floating roof tank			
Covered floating roof tank			
Pressurized or bullet tank			
Tank with agitator or heavy turbulence			



- A stilling well is required in a floating roof tank and a covered floating roof tank.
- Guide wires cannot be installed in a floating roof tank. When the measuring wire is exposed to free space, it may break due to an external shock.
- Installing guide wires is not allowed in pressurized tanks because the wires would prevent closing the valve for replacing the wire, wire drum, or displacer. NMS8x installation position is important for applications without the guide wire system in order to prevent the measuring wire from being broken.

Mounting with a stilling well

The stilling well diameter that is required to protect the measuring wire without disturbing its operation varies depending on the tank height. The stilling well could either be of constant diameter, or narrower at its upper part and wider at its lower part. The following figure shows two examples of the latter case, namely a concentric stilling well and an asymmetric stilling well.

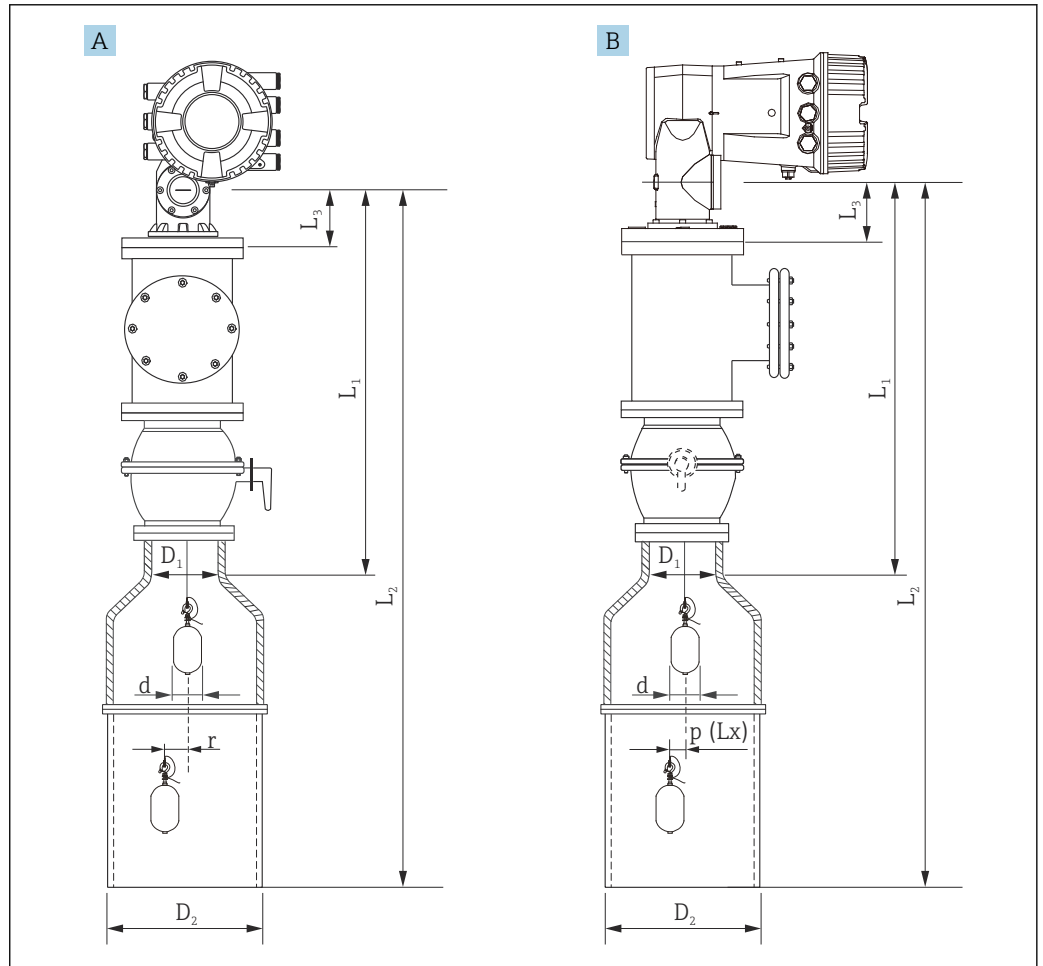

A0029577

14 Mounting with concentric stilling well

A Front view

B Side view

L_1 Length from the center of the calibration window to the upper part of the stilling well

L_2 Length from the center of the calibration window to the bottom of the stilling well

L_3 Length from the center of the calibration window to the bottom of the flange

D_1 Diameter of upper part of stilling well

D_2 Diameter of stilling well

d Diameter of displacer

p Longitudinal wire position from the center of the flange

(Lx)

r Radial direction offset

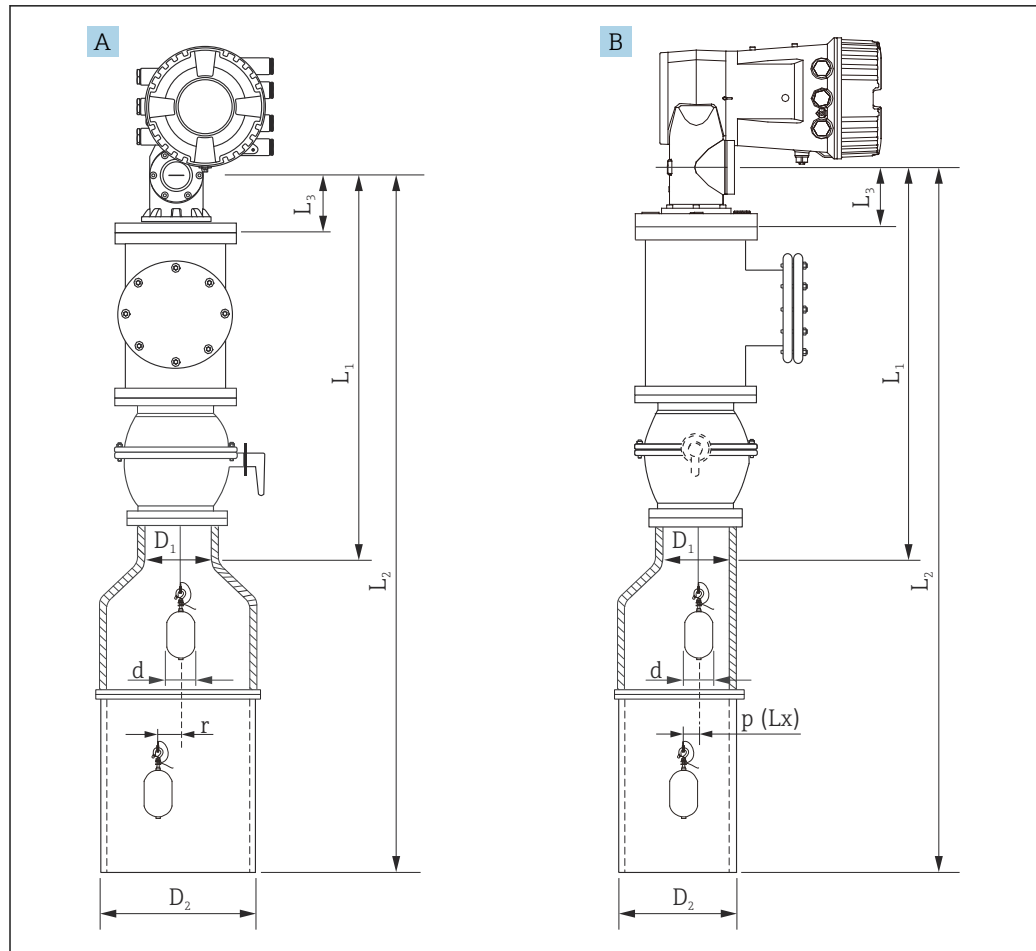

A0029576

15 Mounting with asymmetric stilling well

A Front view

B Side view

L_1 Length from the center of the calibration window to the upper part of the stilling well

L_2 Length from the center of the calibration window to the bottom of the stilling well

L_3 Length from the center of the calibration window to the bottom of the flange

D_1 Diameter of upper part of stilling well

D_2 Diameter of stilling well

d Diameter of displacer

p Longitudinal wire position from the center of the flange

(Lx)

r Radial direction offset

- i** L_3 : length from center of the calibration window to the bottom of the flange built-in NMS8x (77 mm (3.03 in) + flange thickness).
For JIS 10K 150A RF, the flange thickness is 22 mm (0.87 in).
- When using an asymmetric stilling well, take into account the lateral shift of the displacer and follow the NMS8x mounting direction as shown in the figure.
- To calculate the required stilling well diameters, the formula below should be used. The following tables contain the necessary parameters in order to calculate the dimensions of the stilling well. Be sure to have appropriate dimensions of the stilling well according to each dimension in the table.
- The radial direction offset (r) is required for only the 47 m (154.20 ft) and 55 m (180.45 ft) wire drum. For all other drums, the offset is 0 mm/in.

Feature: 110	Description (Measuring range; Wire; Diameter)	NMS80	NMS81	NMS83	r
G1	47 m (154.20 ft); 316L; 0.15 mm (0.00591 in)		<input checked="" type="checkbox"/>		6 mm (0.24 in)
H1	55 m (180.45 ft); 316L 0.15 mm (0.00591 in)		<input checked="" type="checkbox"/>		6 mm (0.24 in)

Feature: 120	Description (Displacer material; Type)	NMS80	NMS81	NMS83	d
1AA	316L; 30 mm (1.18 in) cylindrical	<input checked="" type="checkbox"/>	<input checked="" type="checkbox"/>		30 mm (1.18 in)
1AC	316L; 50 mm (1.97 in) cylindrical	<input checked="" type="checkbox"/>	<input checked="" type="checkbox"/>		50 mm (1.97 in)
1BE	316L; 70 mm (2.76 in) conical	<input checked="" type="checkbox"/>	<input checked="" type="checkbox"/>		70 mm (2.76 in)
1BJ	316L; 110 mm (4.33 in) conical	<input checked="" type="checkbox"/>	<input checked="" type="checkbox"/>		110 mm (4.33 in)
2AA	PTFE; 30 mm (1.18 in) cylindrical	<input checked="" type="checkbox"/>	<input checked="" type="checkbox"/>		30 mm (1.18 in)
2AC	PTFE; 50 mm (1.97 in) cylindrical	<input checked="" type="checkbox"/>	<input checked="" type="checkbox"/>		50 mm (1.97 in)
3AC	AlloyC276; 50 mm (1.97 in) cylindrical	<input checked="" type="checkbox"/>	<input checked="" type="checkbox"/>		50 mm (1.97 in)
4AC	316L polished; 50 mm (1.97 in) cylindrical			<input checked="" type="checkbox"/>	50 mm (1.97 in)
4AE	316L polished; 70 mm (2.76 in) conical			<input checked="" type="checkbox"/>	70 mm (2.76 in)
5AC	PTFE; 50 mm (1.97 in) cylindrical, hygienic white			<input checked="" type="checkbox"/>	50 mm (1.97 in)

Parameter	Description
d	Diameter of displacer
p(Lx)	Longitudinal wire position from the center of the flange The value can be determined by using following graph.
r	Radial direction offset
s	Safety factor recommended: 5 mm (0.197 in)

The following graph shows the lateral shift of the displacer depending on the measured distance for the different wire drums.

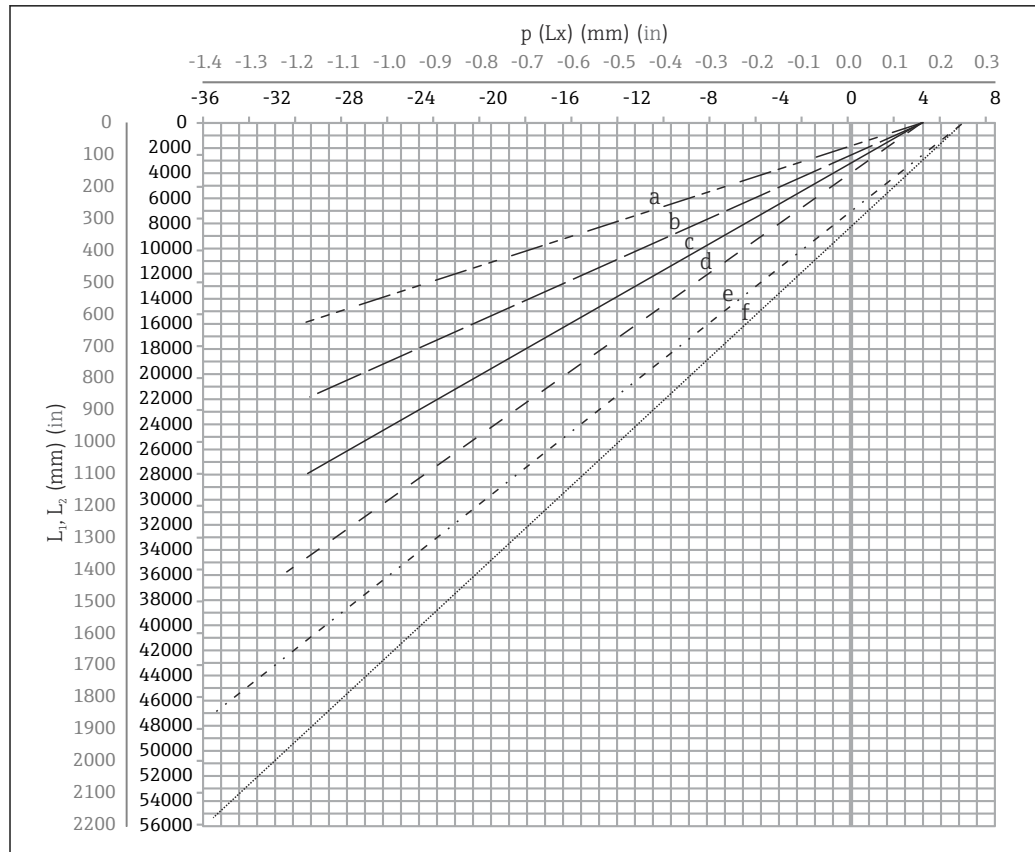

A0027997

16 Lateral shift of displacer according to measurement range

- a 16 m (A3) (NMS80/NMS81/NMS83)
- b 22 m (C2) (NMS80/NMS81/NMS83)
- c 28 m (D1) (NMS80/NMS81)
- d 36 m (F1) (NMS80/NMS81)
- e 47 m (G1) (NMS81)
- f 55 m (H1) (NMS81)

Upper diameter of stilling well

The dimension of D_1 has to be the largest value of the dimensions D_{1a} , D_{1b} , D_{1c} , and D_{1d} according to the following formula.

D ₁ Dimension (Example)	D _{1x} Dimension		Description	Formula
	Example	Parameter		
>68.1 mm (2.68 in)	68.1 mm (2.68 in)	D _{1a}	D ₁ dimension when the displacer is at the center of the calibration window	$= 2 \times (p(0) + d/2 + s)$
	65.6 mm (2.58 in)	D _{1b}	D ₁ dimension when the displacer is at the upper part of the stilling well	$= 2 \times (p(L_1) + d/2 + s)$

D ₁ Dimension (Example)	D _{1x} Dimension		Description	Formula
	Example	Parameter		
	50.9 mm (2.00 in)	D _{1c}	D ₁ dimension when the displacer is at the bottom of the stilling well	$= 2 \times (p (L_2) + s)$
		D _{1d}	D ₁ dimension when the radial direction offset is considered. This calculation is used only with the 47 m (154.20 ft) wire drum (G1 in Feature110) and 55 m (180.45 ft) (H1 in feature 110)	$= 2 \times (d/2 + r + s)$

 Example: L₁ = 1 000 mm, L₂ = 20 000 mm, d = 50 mm, s = 5.0, 28 m drum

Lower diameter of stilling well

The dimension of D₂ has to be the larger value of the dimensions D₁ and D_{2b}.

See the table below.

Concentric pipe

D ₂ Dimension (Example)	D _{2x} Dimension		Description	Formula
	Example	Parameter		
>100.9 mm (3.97 in)	68.1 mm (2.68 in)	D ₁	Calculated D ₁ value	
	100.9 mm (3.97 in)	D _{2b}	D ₂ dimension when the displacer is in L ₂ length	$= 2 \times (p (L_2) + d/2 + s)$

 Example: L₂ = 20 000 mm, d = 50 mm, s = 5.0, 28 m drum

Asymmetric pipe

D ₂ Dimension (Example)	D _{2x} Dimension		Description	Formula
	Example	Parameter		
>84.5 mm (3.33 in)	68.1 mm (2.68 in)	D ₁	Calculated D ₁ value	
	84.5 mm (3.33 in)	D _{2b}	D ₂ dimension that the displacer can pass through (nth groove)	$= p (L_2) + d/2 + s + D_1/2$

 Example: L₂ = 20 000 mm, d = 50 mm, s = 5.0, 28 m drum

Recommendations for NMS8x mounting with a stilling well

 Follow the recommendations for mounting NMS8x with a stilling well.

- Keep the pipe connection welds smooth.
- When drilling holes into the pipe, keep the interior surface of the holes clear of metal chips and burrs.
- Coat or paint the interior surface of the pipe to prevent corrosion.
- Keep the pipe as vertical as possible. Check using a plumb bob.
- Install the asymmetric pipe under the valve and align the centers of the NMS8x and the valve.
- Set the center of the lower part of the asymmetric pipe in the direction of the lateral motion.
- Observe the recommendations as per API MPMS chapter 3.1B.
- Confirm grounding between NMS8x and the tank nozzle.

Mounting with guide wires

It is also possible to guide the displacer with guide wires to prevent swinging.

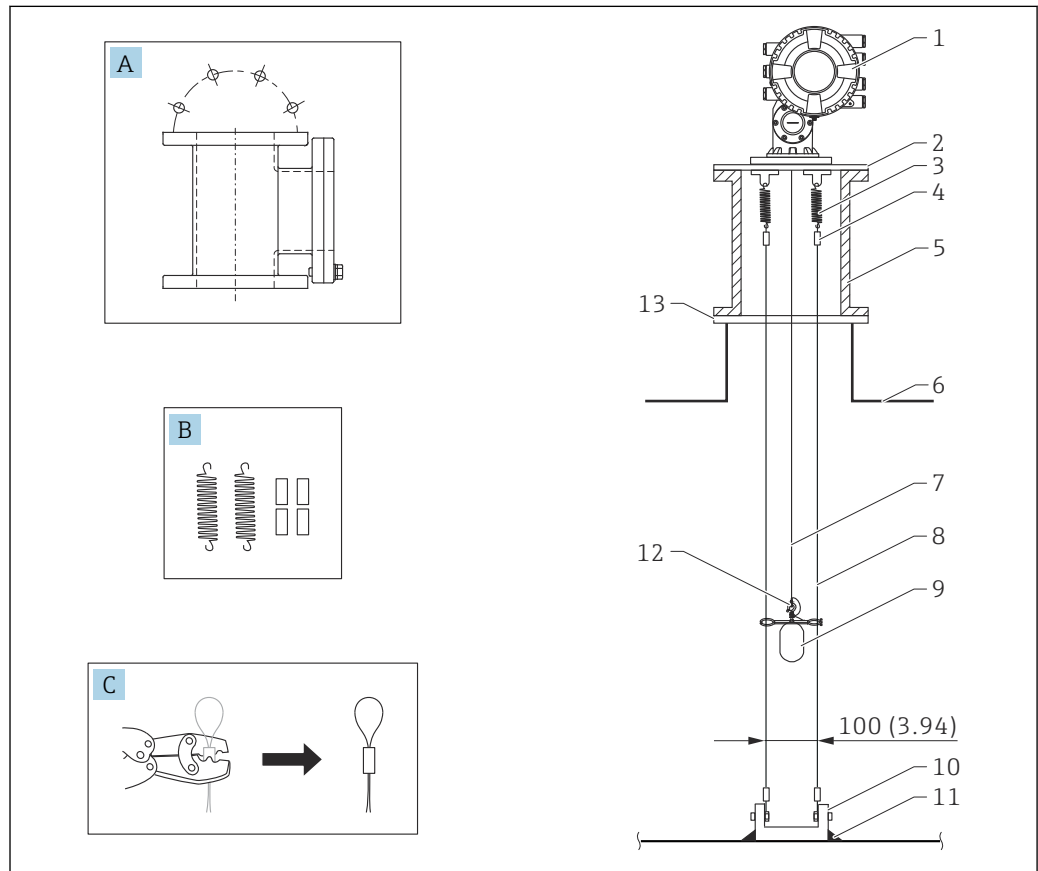

A0026819

17 Guide wire; dimensions mm (in)

No.	Description
A	Maintenance chamber
B	Spring and sleeve
C	Crimp tool and guide wire sleeve
1	NMS8x
2	3 to 6" Reducer plate (incl. guide wire option)
3	Spring, 304 (incl. guide wire option)
4	Sleeve, 316 (incl. guide wire option)
5	Maintenance chamber
6	Tank
7	Measuring wire
8	Guide wire, 316 (incl. guide wire option)
9	Displacer with rings (incl. guide wire option)
10	Anchor hook plate, 304 (incl. guide wire option) <ul style="list-style-type: none"> ▪ 100 mm (3.94 in) for D50 mm (1.97 in) ▪ 110 mm (4.33 in) for D70 mm (2.76 in)
11	Welding point
12	Wire ring, 316L
13	Flange

Guide ring dimension

The dimension of the guide ring is shown below.

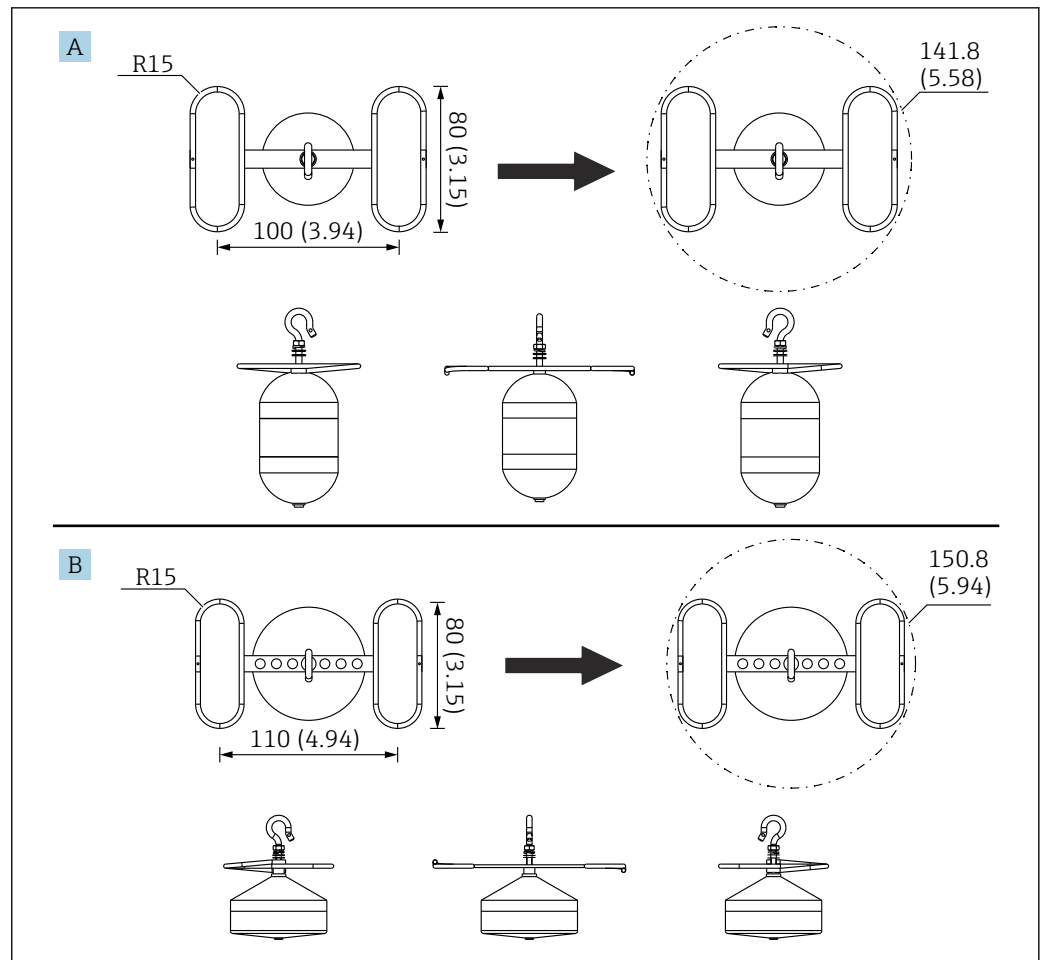

A0055638

18 Guide ring

A Ø50 mm (1.97 in) 316L cylindrical displacer

B Ø70 mm (2.76 in) 316L conical displacer

Environment

Ambient temperature range	Device	-40 to +60 °C (-40 to +140 °F)
	Display module	-20 to +70 °C (-4 to +158 °F)  The readability of the display may be impaired at temperatures outside this temperature range.
Classification of environmental conditions according to DIN EN 60721-3-4	4M4	
Storage temperature	-50 to +80 °C (-58 to +176 °F)	
Humidity	≤ 95 %	
Degree of protection	<ul style="list-style-type: none"> ▪ IP66/68 according to DIN EN 60529 ▪ Type 6P/4X according to NEMA 250 	
Shock resistance	<ul style="list-style-type: none"> ▪ 10 g (11 ms) according to IEC 60721-3-4 (1995) ▪ Classification according to IEC 60721-3-4: 4M4 (1995) <p>The test condition shows it without displacer.</p>	
Vibration resistance	<ul style="list-style-type: none"> ▪ 9 to 200 Hz, 1g (10m/s²) according to IEC 60721-3-4 (1995) ▪ Classification according to IEC 60721-3-4: 4M4 (1995) <p>The test condition shows it without displacer.</p>	
Electromagnetic compatibility (EMC)	<ul style="list-style-type: none"> ▪ Transient emissions according to DIN EN 61326, class B ▪ Interference resistance according to DIN EN 61326, Appendix A (Industry use) and NAMUR recommendation NE21 	
Maximum use altitude	2 000 m (6 561.68 ft) above sea level	

Process

Process temperature range -200 to +200 °C (-328 to 392 °F)

i If the application exceeds the range listed above, contact Endress+Hauser for technically special products / solutions.

Process sealing

A1	HNBR	-30 to 150 °C (-22 to 302 °F)
B1	FKM	-40 to 200 °C (-40 to 392 °F)
C1	CR Chloropren	-30 to 100 °C (-34 to 212 °F)
D1	PTFE (Wire drum FKM)	<ul style="list-style-type: none"> ▪ PTFE: -100 to 200 °C (-148 to 392 °F) ▪ Wire drum FKM: -40 to 200 °C (-49 to 392 °F)
E1	VMQ silicone	-45 to 200 °C (-49 to 392 °F)

i A temperature difference exists between the liquid in the tank and the NMS8x on the tank nozzle due to the distance from each other. Also, the process sealing temperature of NMS8x does not show the temperature for the liquid temperature. The process sealing temperature shows the temperature of the gas that reaches inside the housing of the NMS8x. In most cases, the gas temperature is the same as the ambient temperature. If there are any temperature differences between the process sealing and the gas, install a pipe or chamber between the NMS8x and the tank nozzle to adjust the temperature or cover the tank with a heat insulating material to control the temperature.

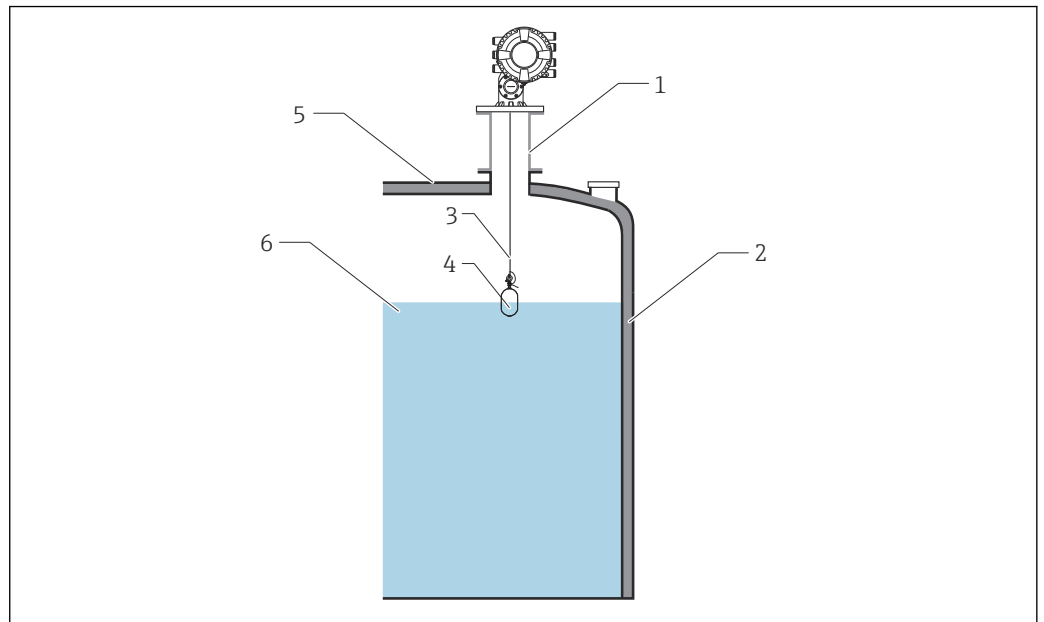

19 Process sealing

- 1 Chamber or pipe for adjusting temperature
- 2 Heat insulating material
- 3 Measuring wire
- 4 Displacer
- 5 Tank wall
- 6 High or low temperature liquid

Process pressure range

Housing type	Process pressure range
Aluminum	0 to 6 bar (600 kPa/87 psi)

Medium density 0.430 to 2.000 g/cm³ (27 to 125 lb/ft³)

-  If the application exceeds the range listed above, contact Endress+Hauser for technically special products / solutions.
- When moving a displacer down into the liquid at the point of the interface or density measurement, see the table below.

Diameter [mm]	Material	Weight [g]	Volume [ml]	Minimum density range [g/cm ³]	Maximum density range [g/cm ³]
30	316L	261	84.3	0.237	2.266
30	PTFE	250	118	0.169	1.525
50	316L/AlloyC276	253	143	0.140	1.280
50	PTFE	250	118	0.169	1.525
70	316L	245	124	0.161	1.411
110	316L	223	108	0.185	1.417

Medium density difference for interface measurement 0.1 g/cm³ (6.24 lb/ft³)

Viscosity 0 to 5 000 mPa·s

Maximum displacer movement speed Approx. 2 200 mm (86.61 in) / min

-  The displacer speed will be slow down in the area in front of 30 mm in order to stop at the proper position according to the low stop setting which has been specified.

Custody transfer approval

As a prerequisite for custody transfer approval, the device ordered must show either option ITA, ITB, ITC or ITD on ordering feature 150 "Accuracy, Weight + Measure approval".

Options of ordering feature 590 "Additional Approval"

- **LK**
NMI witnessed initial verification accuracy, Weight + Measure approval
- **LL**
PTB witnessed initial verification accuracy, Weight + Measure approval
- **LN**
LNE witnessed initial verification accuracy, Weight + Measure approval
- **LO**
*NMI type approval
- **LP**
*PTB type approval
- **LQ**
*LNE type approval
- **LT**
METAS, custody transfer
- **LU**
BEV, custody transfer



- Depending on the displacer (ordering feature 120) some of these versions will not be available.
- Proservo NMS8x that are certified for Custody Transfer applications are calibrated on a certified production rig. The production rig reference standard is a laser tracker with an absolute accuracy of ± 0.010 mm and a resolution of 0.0002 mm. Calibration is performed at 10 equally-spaced measuring points over the full measuring range (up to 40 m (131 ft)). Additionally, hysteresis is checked at three points.
- The Maximum Permissible Error (MPE) is 0.4 mm (0.016 in) for maximum performance models, and ± 1 mm (± 0.04 in) for custody transfer models. The resultant factory calibration certificate is included in the scope of delivery along with the respective type approval certificate.
- Ten-point calibration which is tested in accordance with ISO/IEC 17025, certified by Japan Accreditation Board (JAB) of ILAC MRA, according to the international reference standard (étalon)

Mechanical construction

Dimensions

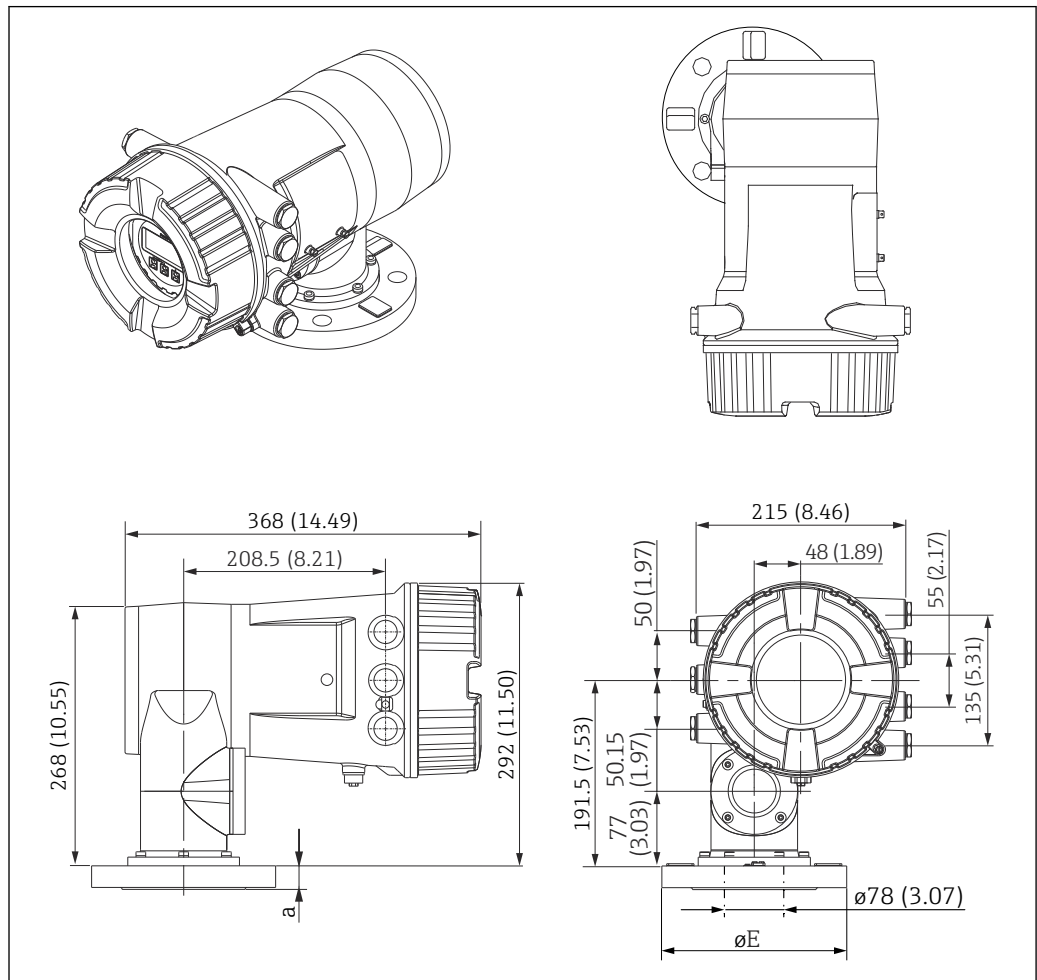

A0029578

Flanges according to ASME B16.5. Pressure rating 150 lbs¹⁾

D ²⁾	E ³⁾		
	3"	6"	8"
a	23.9 mm (0.94 in)	25.4 mm (1 in)	28.4 mm (1.12 in)
øE	ø190 mm (7.5 in)	ø279 mm (10.98 in)	ø343 mm (13.5 in)

- 1) Ordering feature 140 (position AFA, AHA, and AJA of the order code)
- 2) Dimension
- 3) Nominal diameter

Flanges according to EN1092-1, Pressure rating PN10/16¹⁾

D ²⁾	E ³⁾
	DN80
a	20 mm (0.79 in)
øE	ø200 mm (7.87 in)

- 1) Ordering feature 140 (position GSA of the order code)
- 2) Dimension
- 3) Nominal diameter

Flanges according to JIS B2220, Pressure rating 10 K¹⁾

D ²⁾	E ³⁾		
	80A RF	80A FF	150A RF
a	22 mm (0.87 in)	22 mm (0.87 in)	26 mm (1.02 in)
φE	φ185 mm (7.28 in)	φ185 mm (7.28 in)	φ280 mm (11 in)

- 1) Ordering feature 140 (position PFA, PHA, and P5A of the order code)
- 2) Dimension
- 3) Nominal diameter

Flanges according to JPI 7S-15, Pressure rating 150 lbs¹⁾

D ²⁾	E ³⁾
	80A RF
a	24.3 mm (0.96 in)
φE	φ190 mm (7.48 in)

- 1) Ordering feature 140 (position QFA of the order code)
- 2) Dimension
- 3) Nominal diameter

Weight

- Approx. 15 kg (33.0 lb) with NPS 3" Cl. 150, DN80PN10/16, 10K80A flange
- Approx. 20 kg (44.1 lb) with NPS 6" Cl. 150 flange
- Approx. 24 kg (52.9 lb) with NPS 8" Cl. 150 flange

 The weights vary depending on the selected options.

Materials

Material of housing

Transmitter + process Alu, coated

- Feature
070
- Option
AB

Materials of measuring wire

Ordering feature 110, various options

O ¹⁾	W ²⁾
A3	16 m (52.49 ft); PFA >316L; 0.4 mm (0.016 in)
C2	22 m (73.33 ft); AlloyC276; 0.2 mm (0.008 in)
D1	28 m (93.33 ft); 316L; 0.15 mm (0.006 in)
F1	36 m (120 ft); 316L; 0.15 mm (0.006 in)

- 1) Option
- 2) Wire descriptions

 The material of the wire drum is SUS316L.

Material of process connection (flange)

NPS 3" Cl.150 RF, Aluminum flange ASME B16.5
 Option of ordering feature 140 ("Process Connection")
 AFA

NPS 6" Cl.150 RF, Aluminum flange ASME B16.5

Option of ordering feature 140 ("Process Connection")
AHA

DN80 PN10/16 B1, Aluminum flange EN1092-1

Option of ordering feature 140 ("Process Connection")
GSA

10K 80A RF, Aluminum flange JIS B2220

Option of ordering feature 140 ("Process Connection")
PFA

10K 150A RF, Aluminum flange JIS B2220

Option of ordering feature 140 ("Process Connection")
PHA

10K 80A FF, Aluminum flange JIS B2220

Option of ordering feature 140 ("Process Connection")
P5A

80A 150lbs RF, Aluminum flange JPI 7S-15

Option of ordering feature 140 ("Process Connection")
QFA

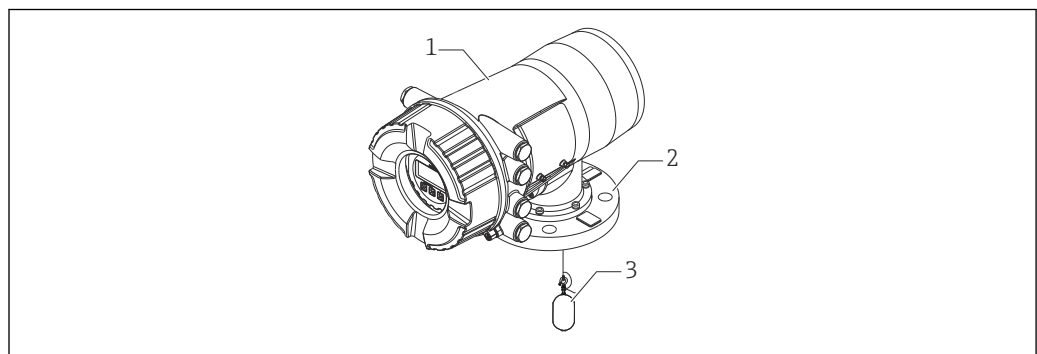

A0029583

- 1 Housing
- 2 Flange
- 3 Measuring wire

Parts according to NACE standard

In accordance with NACE MR 0175 and NACE MR 0103, the following parts highlighted in blue are available as NACE standard materials. For further information of standards, → 53

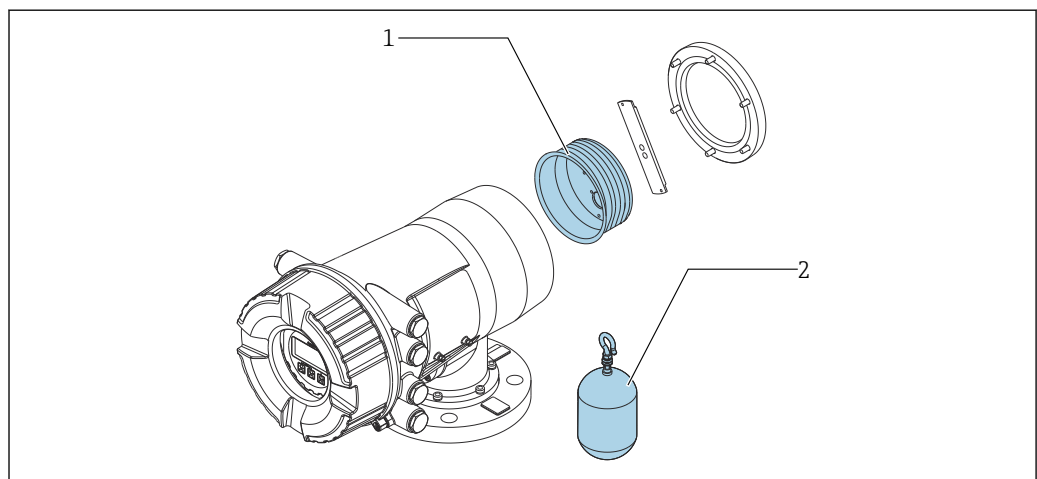

A0050788

20 Parts according to NACE standard

- 1 Wire drum (28 m (91.86 ft))
- 2 Displacer (50 mm (1.97 in), 70 mm (2.76 in) / 50 mm (1.97 in) with guide ring, 70 mm (2.76 in) with guide ring)

Operability

Operating concept

Operator-oriented menu structure for user-specific tasks

- Commissioning
- Operation
- Diagnostics
- Expert level

Operating languages

- English
- Chinese
- German
- Japanese
- Spanish

 Feature 500 of the product structure determines which of these languages is preset on delivery.

Quick and safe commissioning

- Guided menus ("Make-it-run" wizards) for applications
- Menu guidance with brief explanations of the individual parameter functions

Reliable operation

Standardized operation at the device and in the operating tools

Efficient diagnostics increase measurement reliability

- Remedy information is integrated in plain text
- Diverse simulation options

Operating options

- Local display; operation via the local display is possible without opening the device.
- Tank Gauging system
- Plant Asset Management tool (e.g. FieldCare); connected via
 - HART
 - Service port (CDI)

Local operation

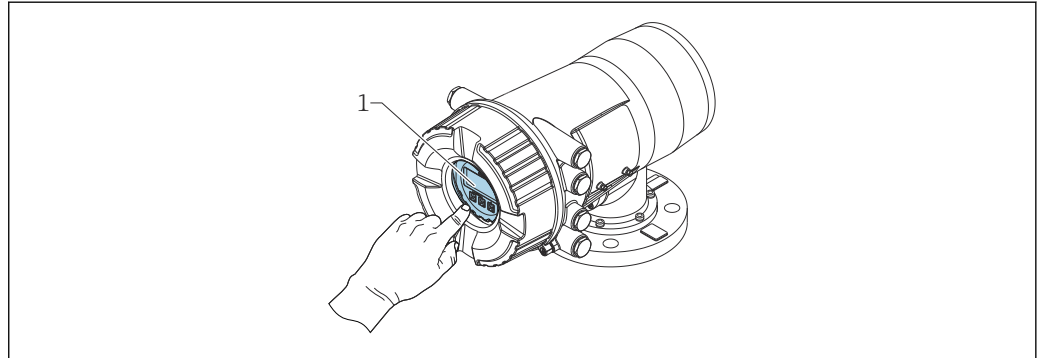

A0029584



 21 NMS80 Display

1 Display

Display elements

- 4-line display
 - White background lighting; switches to red in event of device errors
 - Format for displaying measured variables and status variables can be individually configured
 - Permitted ambient temperature for the display: -20 to +70 °C (-4 to +158 °F)
- The readability of the display may be impaired at temperatures outside the temperature range.

Operating elements

- External operation via touch control; 3 optical keys: , , 
- Operating elements also accessible in various hazardous areas

Remote display and operating module DKX001

The display and operating elements correspond to those of the display module.

Depending on the installation location, the remote display module DKX001 provides better access to the operating elements than the display on the device.

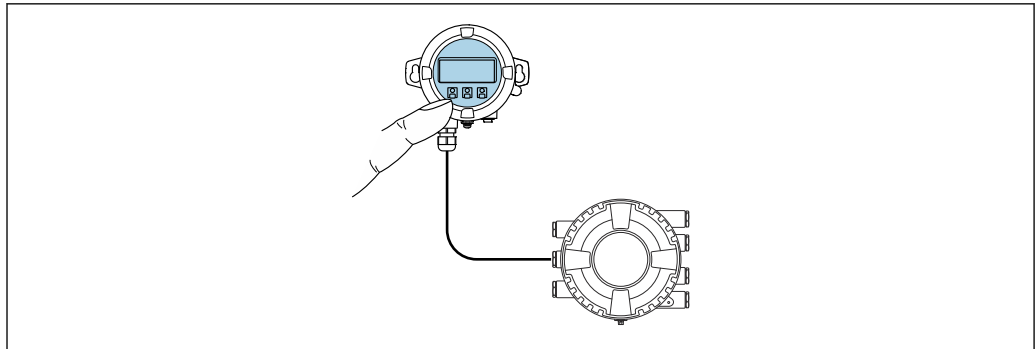

A0042197

22 Operation via remote display and operating module DKX001

i The remote display and operating module DKX001 is available as an accessory. For details refer to SD01763D.

- i**
 - The measured value is indicated on the DKX001 and on the local display and operating module simultaneously.
 - The operating menu cannot be accessed on both modules at the same time. If the operating menu is entered in one of these modules, the other module is automatically locked. This locking remains active until the menu is closed in the first module (back to measured value display).

The housing material of the display and operating module DKX001 can be selected in the order code. There are 2 options : alu and stainless steel.

Remote operation

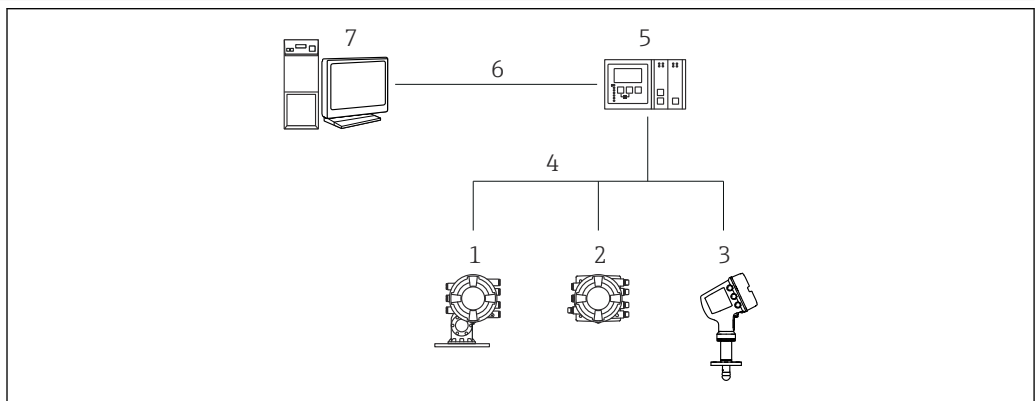

A0025621

23 Remote operation of Tank Gauging devices

- 1 Proservo NMS8x
- 2 Tankside Monitor NRF81
- 3 Micropilot NMR8x
- 4 Field protocol (e.g. Modbus, V1)
- 5 Tankvision Tank Scanner NXA820
- 6 Ethernet
- 7 Computer with operating tool (e.g. FieldCare)

Operation via service interface

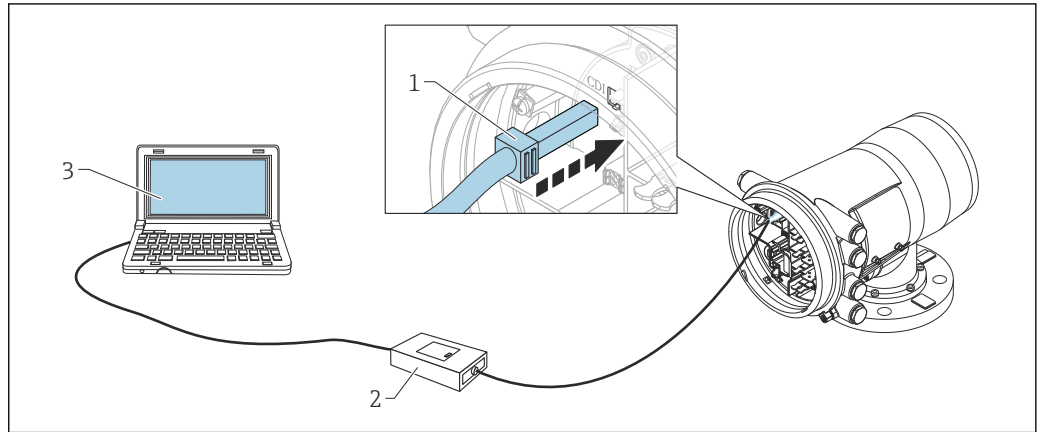

A0030161



24 Operation via service interface

- 1 Service interface (CDI = Endress+Hauser Common Data Interface)
- 2 Commubox FXA291
- 3 Computer with "FieldCare" operating tool and "CDI Communication FXA291" COM DTM

Certificates and approvals

Current certificates and approvals for the product are available at www.endress.com on the relevant product page:

1. Select the product using the filters and search field.
2. Open the product page.
3. Select **Downloads**.

CE mark	<p>The measuring system meets the legal requirements of the applicable EU guidelines. These are listed in the corresponding EU Declaration of Conformity together with the standards applied.</p> <p>Endress+Hauser confirms successful testing of the device by affixing to it the CE mark.</p>
RCM marking	<p>The supplied product or measuring system meets the ACMA (Australian Communications and Media Authority) requirements for network integrity, interoperability, performance characteristics as well as health and safety regulations. Here, especially the regulatory arrangements for electromagnetic compatibility are met. The products bear the RCM marking on the nameplate.</p> <div style="text-align: center; border: 1px solid black; width: 100px; height: 100px; margin: 10px auto;">  </div> <p style="text-align: right; font-size: small;">A0029561</p>
Ex approval	<p>Certificates are available online for the following approval types.</p> <ul style="list-style-type: none"> ▪ AEx ▪ ATEX ▪ EAC Ex ▪ FM C/US ▪ IEC Ex ▪ INMETRO Ex ▪ JPN Ex ▪ KC Ex ▪ NEPSI <p> Currently available certificates and approvals can be called up via the product configurator.</p> <p>Additional safety instructions must be followed for use in hazardous areas. Please refer to the separate "Safety Instructions" (XA) document included in the delivery. Reference to the applicable XA can be found on the nameplate.</p> <p> The separate documentation "Safety Instructions" (XA) containing all the relevant explosion protection data is available from your Endress+Hauser Sales Center.</p>
Single seal according to ANSI/ISA 12.27.01	<p>The devices have been designed according to ANSI/ISA 12.27.01 as single seal devices, allowing the user to waive the use and save the cost of installing external secondary process seals in the conduit as required by the process sealing sections of ANSI/NFPA 70 (NEC) and CSA 22.1 (CEC) These instruments comply with the North-American installation practice and provide a very safe and cost-saving installation for pressurized applications with hazardous fluids.</p> <p>Further information can be found in the Safety Instructions (XA) of the relevant devices.</p>
Functional Safety (SIL)	<p>Use for level monitoring (MIN, MAX, range) up to SIL 2/3 according to IEC 61508:2010.</p> <p>For details refer to the "Functional Safety Manual": FY01099G</p>
WHG	DIBt: Z-65.16-589
Weight & Measure approval	<ul style="list-style-type: none"> ▪ OIML R85 (2008) ▪ NMi ▪ PTB

- PAC
- LNE
- WELMEC

 The device has a sealable locking switch according to the Weight & Measure requirements. This switch locks all software parameters related to the measurement. The switching status is indicated on the display and via the communication protocol.

CRN approval

Some device versions have a CRN approval. Devices are CRN approved if the following two conditions are met:

- The CRN approval is selected (Product structure: Feature 590 "Additional Approval", option LD "CRN")
- The device has a CRN approved process connection according to the following table:

Feature 140: Process Connection	Meaning
AFA	NPS 3" Cl.150 RF, aluminum flange ASME B16.5
AHA	NPS 6" Cl.150 RF, aluminum flange ASME B16.5
AJA	NPS 8" Cl.150 RF, aluminum flange ASME B16.5

-  ■ Process connections without CRN approval are not included in this table.
 ■ CRN approved devices are marked with the registration number OF18152.5C on the nameplate.

Test, certificate

Ordering feature 580 "Test, Certificate"	Designation
JA	3.1 Material certificate, wetted metallic parts, EN10204-3.1 inspection certificate
KE	Pressure test, internal procedure, inspection certificate
KF	Air tightness test, internal procedure, inspection certificate
KO	Liquid penetrant test JIS B 8266 (PT), wetted/pressurized seams, test report
KS	Welding documentation, wetted/pressurized seams

Other standards and guidelines

Industry standards

- Directive 2011/65/EU: "Restriction of Hazardous Substances" (RoHS)
- Directive 2014/32/EC: "Measuring Instruments Directive" (MID)
- IEC61508: "Functional Safety of Electrical/Electronic/Programmable Electronic Safety-related Systems" (SIL)
- NACE MR 0175, NACE MR 0103: "Sulfide stress cracking resistant metallic materials for oilfield equipment"
- API Recommended Practice 2350: "Overfill Protection for Storage Tanks in Petroleum Facilities"
- API MPMS: "Manual of Petroleum Measurement Standards"
- EN 1127: "Explosive atmospheres - Explosion prevention and protection"
- IEC 60079: "Equipment protection"
- EN 1092: "Flanges and their joints"
- EN 13463: "Non-electrical equipment for use in potentially explosive atmospheres"
- TIA-485-A: "Electrical Characteristics of Generators and Receivers for Use in Balanced Digital Multipoint Systems "
- IEC61511: "Functional safety - Safety instrumented systems for the process industry sector"
- IEEE 754: "Standard for Binary Floating-Point Arithmetic for microprocessor systems "
- ISO4266: "Petroleum and liquid petroleum products - measurement of level and temperature in storage tanks by automatic methods"
- ISO6578: "Refrigerated hydrocarbon liquids - Static measurement - Calculation procedure"
- ISO 11223: "Petroleum and liquid petroleum products - Determination of volume, density and mass of the contents of vertical cylindrical tanks by Hybrid Tank Measurement Systems"
- ISO15169: "Petroleum and liquid petroleum products - Direct static measurement - Measurement of content of vertical storage tanks by hydrostatic tank gauging"
- JIS K2250: "Petroleum Measurement Tables"
- JIS B 8273: "Bolted flange for pressure vessels"

- G.I.I.G.N.L.: "LNG Custody transfer handbook"
- NAMUR NE043: "Standardization of the Signal Level for the Failure Information of Digital Transmitters"
- NAMUR NE107: "Self-Monitoring and Diagnosis of Field Devices"

Metrological standards

- OIML R85 (2008) "Requirements for ambient temperature low $-25\text{ }^{\circ}\text{C}$ ($-13\text{ }^{\circ}\text{F}$) and ambient temperature high $+55\text{ }^{\circ}\text{C}$ ($+131\text{ }^{\circ}\text{F}$)
- "Mess- und Eichverordnung" (Calibration regulations for the Federal Republic of Germany)
- Directive 2014/32/EC of the European Parliament and of the Council of 26 February 2014 on measuring instruments
- PTB-A-5.01: "Automatic level measuring devices for stationary storage containers"

Calibration

Calibrations with certificates are available by options.

- 3- or 5-point level calibration by factory traceable to an international reference standard (étalon)
- 10-point level calibration by factory traceable to an international reference standard (étalon)
- 10-point level calibration by laboratory traceable to an international reference standard (étalon) conformed to ISO/IEC 17025 accredited by JAB, Japan Accreditation Board, of ILAC MRA

Ordering information

Detailed ordering information is available from your nearest sales organization www.addresses.endress.com or in the Product Configurator at www.endress.com:

1. Select the product using the filters and search field.
2. Open the product page.
3. Select **Configuration**.



Product Configurator - the tool for individual product configuration

- Up-to-the-minute configuration data
- Depending on the device: Direct input of measuring point-specific information such as measuring range or operating language
- Automatic verification of exclusion criteria
- Automatic creation of the order code and its breakdown in PDF or Excel output format
- Ability to order directly in the Endress+Hauser Online Shop

Calibration certificate

A calibration certificate is included if one of the following options is selected in ordering feature 150 ("Accuracy, Weight + Measure Approval").

Option ¹⁾	Meaning	Number of calibration points
ICW	Standard version, 3-point calibration certificate	3
ICX	Standard version, 5-point calibration certificate	5
ITA	Maximum performance, 10-point calibration certificate	10
ITB	Maximum performance, 10-point, extended range, acc. to OIML R85, API 3.1B, ISO4266, factory calibration certificate	10
ITC	Standard version, 10-point calibration certificate	10
ITD	Standard version, 10-point, extended range, acc. to OIML R85, API 3.1B, ISO4266, factory calibration certificate	10

- 1) Option of ordering feature 150 "Accuracy, Weight + Measure Approval", Positions 21 to 23 of the order code



- The calibration points are evenly spaced and spread over the selected calibration range.
- The calibration points are checked under reference conditions.

Marking

Option of ordering feature 895 "Marking"	Meaning
Z1	Tagging (TAG)
Z2	Bus address

Optionally, the device can be ordered with a specific tagging and/or bus address according to the table above. When the respective option is selected, the tag or bus address must be defined in an additional specification.

Shipping condition

To enable turnkey operation and commission, NMS8x is shipped in all-in-one condition except for the following specifications.

- 316L 30 mm (1.18 in) displacer
- 316L 110 mm (4.33 in) displacer
- PTFE 30 mm (1.18 in) displacer

- PTFE 50 mm (1.97 in) displacer
- Guide wire assembly
- Cleaned from oil + grease option

Application packages

Advanced tank measurement methods The device software provides the following tank measurement methods:

- Direct level measurement → 57
- Hybrid tank measurement system (HTMS) → 58
- Hydrostatic tank shell correction (HyTD) → 59
- Thermal tank shell correction (CTSh) → 59

Direct level measurement

If no advanced tank measurement methods have been selected, level and temperature are measured directly.

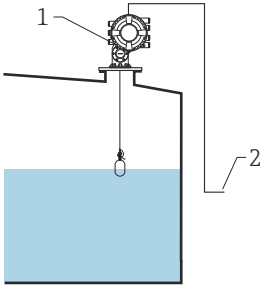
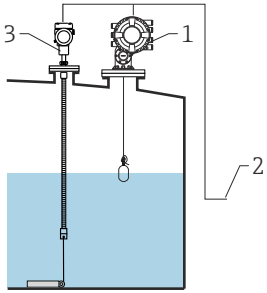

Direct level measurement modes

Measuring mode	Installation example	Measured variables	Calculated variables
Level only	 <p style="text-align: right; font-size: small;">A0026820</p> <p>1 NMS8x 2 To inventory management system</p>	<ul style="list-style-type: none"> ▪ Level 	None
Level + temperature	 <p style="text-align: right; font-size: small;">A0026829</p> <p>1 NMS8x 2 To inventory management system 3 Temperature (spot or average)</p>	<ul style="list-style-type: none"> ▪ Level ▪ Temperature (spot or average) 	None

Hybrid tank measurement system (HTMS)

HTMS uses level and pressure measurements to calculate the contents of the tank and (optionally) the density of the medium.

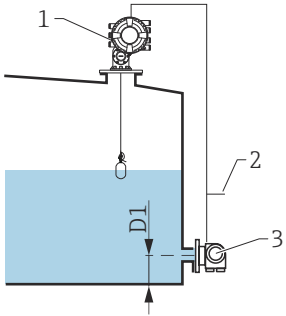
HTMS measuring modes

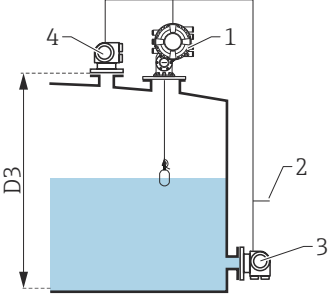
Measuring mode	Installation example	Measured variables	Calculated variables
<p>HTMS + P1</p> <p> This mode should be used in atmospheric (i.e. non-pressurized) tanks</p>	 <p style="text-align: right; font-size: small;">A0026830</p> <p>1 NMS8x 2 To inventory management system 3 Pressure transmitter (bottom)</p>	<ul style="list-style-type: none"> ■ Level ■ Bottom pressure (at position D1) 	<p>Density of the medium</p>
<p>HTMS + P1 + P3</p> <p> This mode should be used in non- atmospheric (i.e. pressurized) tanks</p>	 <p style="text-align: right; font-size: small;">A0026831</p> <p>1 NMS8x 2 To inventory management system 3 Pressure transmitter (bottom) 4 Pressure transmitter (top)</p>	<ul style="list-style-type: none"> ■ Level ■ Bottom pressure (at position D1) ■ Top pressure (at position D3) 	<p>Density of the medium</p>

Hydrostatic tank shell correction (HyTD)

The hydrostatic tank shell correction can be used to compensate for vertical movement of the Gauge Reference Height due to bulging of the tank shell caused by the hydrostatic pressure exerted by the liquid stored in the tank. The compensation is based on a linear approximation obtained from manual hand dips at several levels distributed over the full range of the tank.

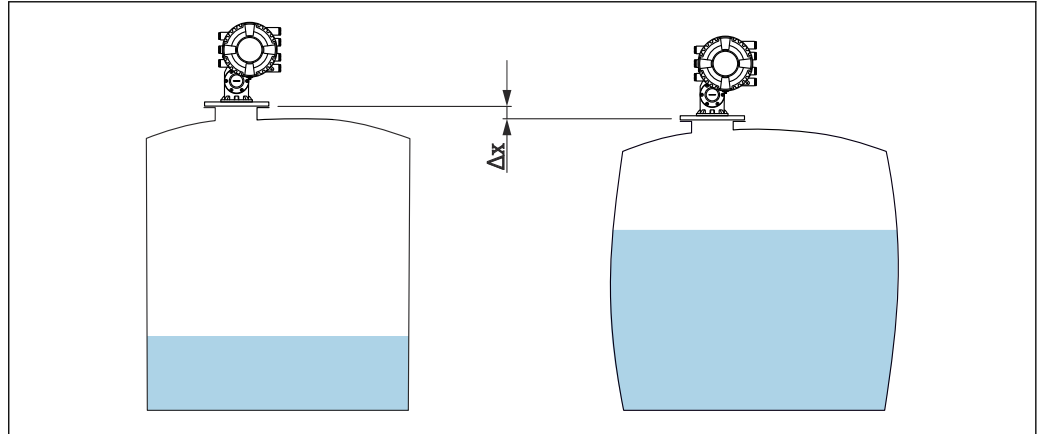

25 Movement Δx of the tank reference height due to the bulging of the tank shell caused by hydrostatic pressure

Thermal tank shell correction (CTSh)

The thermal tank shell correction can be used to compensate for vertical movement of the Gauge Reference Height due to temperature effects on the tank shell or stilling well. The calculation is based on the thermal expansion coefficients of steel and on insulation factors for both the dry and wetted part of the tank shell.

- i
 This correction is recommended for any tank gauge operating at conditions deviating considerably from the conditions during calibration and for extremely high tanks. For refrigerated, cryogenic and heated applications this correction is highly recommended.
- Wire length can also be corrected with the parameters related to CTSh.

Level reference check (LRC)

For tanks where a manual dipping cannot be performed the level gauge can be verified by means of the LRC function.

If the measured level value is not verified by the LRC function applied, the device will issue an error message regarding the measured level.

- i
 This reference check is recommended for liquefied gas applications.

LRC with reference level

The radar device compares its own level reading with the level reading of another level gauge (e.g. Proservo NMS8x). Based on a configurable deviation value (**Allowed difference** parameter), a continuous check is performed.

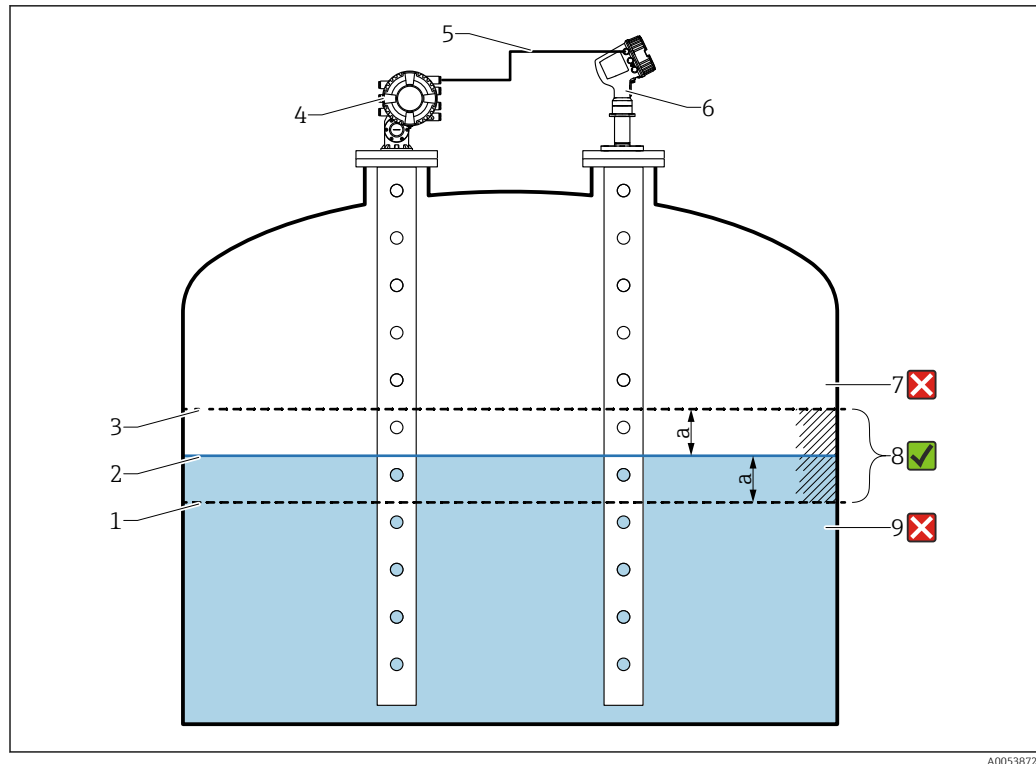

26 Application example with Proservo NMS8x

- 1 Lower limit of deviation value "a" as configured in radar level gauge
- 2 Reference value: Measured level as provided by level gauge Proservo NMS8x
- 3 Upper limit of deviation
- 4 Proservo NMS8x provides the reference value
- 5 Level gauges are interconnected via HART interface
- 6 Radar level gauge with configured deviation value "a" for "Allowed difference" parameter
- 7 The measured level is greater than reference value plus deviation value "a": Level value is not verified
- 8 The measured level is within or equal to the limits defined by the deviation value "a": Level value is verified
- 9 The measured level is less than reference value minus deviation value "a": Level value is not verified

Properties

- Frequency: The reference check is performed continuously every 60 seconds.
- Tolerance: Via the **Check fail threshold** parameter, a configurable number of failures is allowed before the status switches to failed.
- Connection: The level reference device is connected via an optional HART I/O board.
See ordering feature 050: "Secondary I/O Analogue".

LRC with reference switch

A level switch (e.g. Liquiphant FTLx) can be mounted within the tank. The check can be performed continuously, each time the level switch is activated or deactivated. The measured level should remain within a configurable deviation.

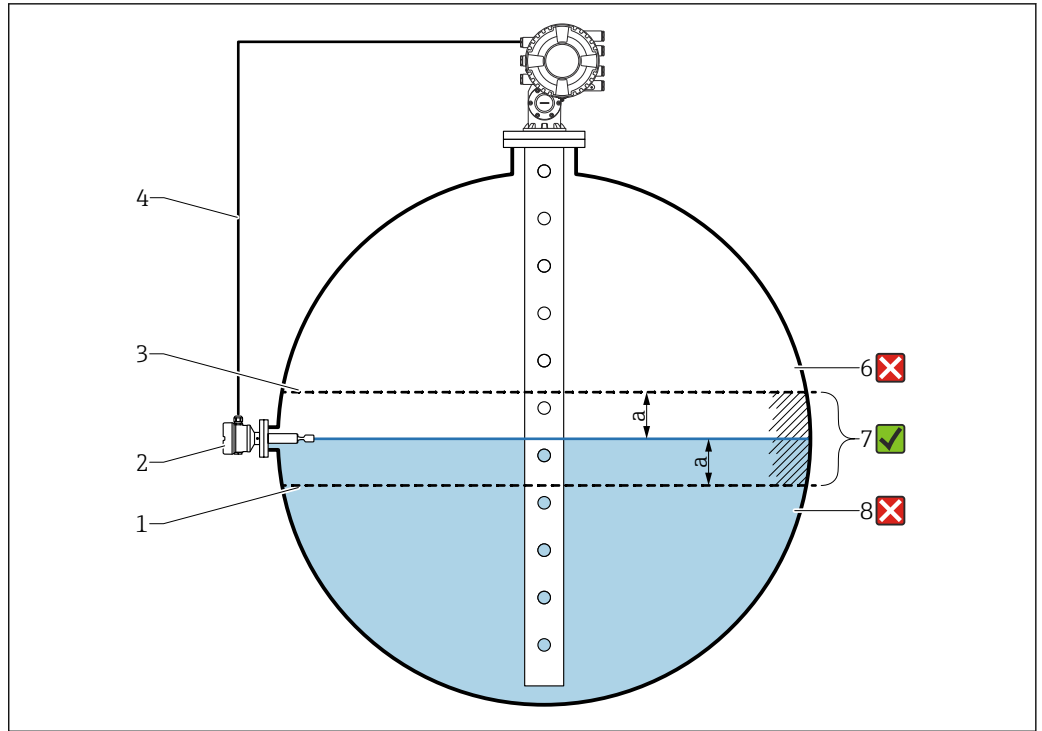

A0054210

27 Application example with level switch

- 1 Lower limit of deviation value "a" as configured in radar level gauge
- 2 Reference value: The switching point of an installed level switch represents the reference value for verification
- 3 Upper limit of deviation
- 4 Level switch and level gauge are interconnected via a digital I/O board
- 5 Radar level gauge with configured deviation value "a" for "Allowed difference" parameter
- 6 The measured level is greater than reference value plus deviation value "a": Level value is not verified
- 7 The measured level is within or equal to the limits defined by the deviation value "a": Level value is verified
- 8 The measured level is less than reference value minus deviation value "a": Level value is not verified

Properties

- Modes: The device can be set to monitor the switching point while filling or draining the tank.
- Connection: The level switch is connected via a digital I/O board.
See ordering feature 060: "Secondary I/O Digital Ex d/XP".

Accessories

Device-specific accessories

Weather protection cover

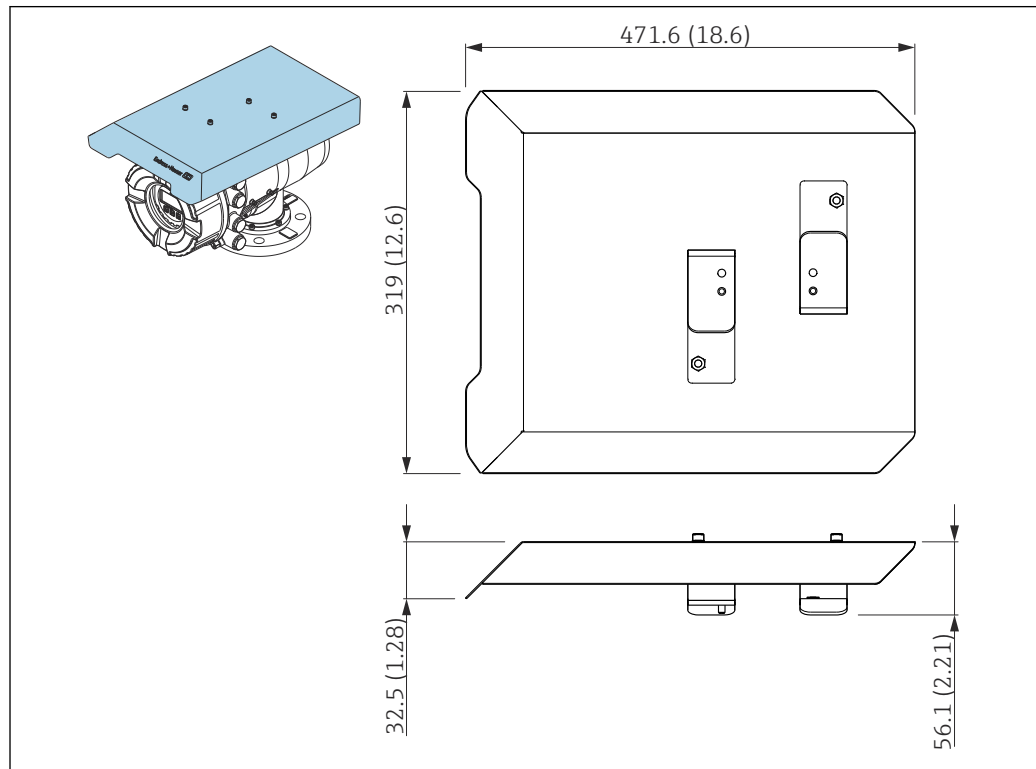

A0029585

28 Weather protection cover; dimensions: mm (in)

Materials

- Protection cover and mounting brackets

Material
316L (1.4404)

- Screws and washers

Material
A4

- The weather protection cover can be ordered together with the device:
Ordering feature 620 "Accessory Enclosed", option PA "Weather Protection Cover")
 - It can also be ordered as an accessory:
Order code: 71305035 (for NMS8x)

Maintenance chamber

A maintenance chamber is recommended for use with tank level gauges in order to allow maintenance (removing the 70 mm (2.76 in) displacer or larger), while the tank is in service. Contact your Endress+Hauser Sales Center if necessary.

Ball valve

Ball valves are recommended for use with tank level gauges in order to allow maintenance such as removing displacers while tank is in service. Contact your Endress+Hauser Sales Center if necessary.

Control switch

A control switch is used for field mounted tank gauges. This provides additional gauge operation contact switching in order to control the gauge's operation, such as hoisting up the displacer. Contact your Endress+Hauser Sales Center if necessary.

Relief valve and pressure gauge

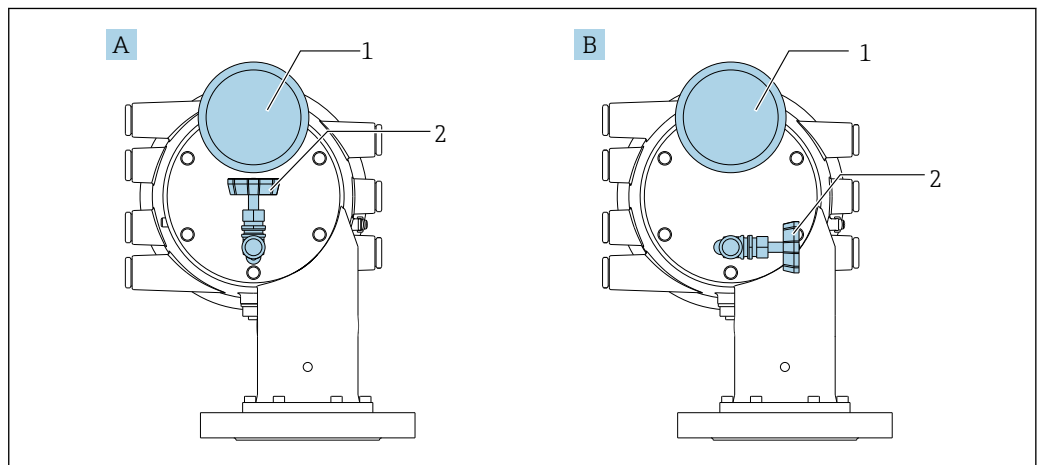

A0029104

29 Mounting position of relief valve and pressure gauge

- A Standard version
- B 90°-degree rotation (optional)
- 1 Pressure gauge
- 2 Relief valve

Relief valve

A relief valve is used to release pressure inside the housing of NMS8x before maintenance.

Process temperature: -20 to 150 °C (-4 to 302 °F)

 Contact your Endress+Hauser Sales Center when applying pressure in an ammonia atmosphere.

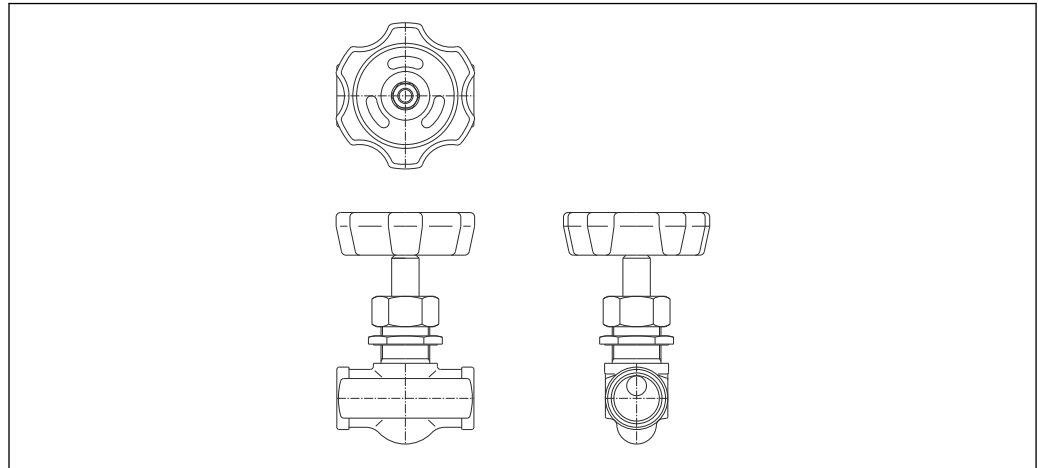

A0028881

 30 Relief valve

Pressure gauge

A pressure gauge is used to check process pressure inside the housing. The range of the scale for the pressure gauge varies depending on the pressure.

- Low pressure: 0 to 1 MPa
- High pressure: 0 to 4 MPa

Process temperature: -5 to 45 °C (23 to 113 °F)

 Contact your Endress+Hauser Sales Center when applying pressure in an ammonia atmosphere.

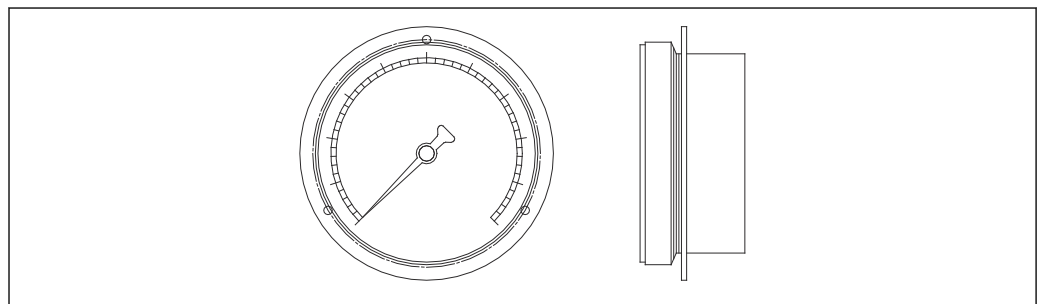

A0028882

 31 Pressure gauge

Cleaning nozzle and gas purging nozzle

A cleaning nozzle used for washing inside housing is especially recommended for F&B or alcohol applications.

A gas purging nozzle used for purging gas inside the housing is especially recommended for a nitrogen blanket for petrochemical or chemical applications.

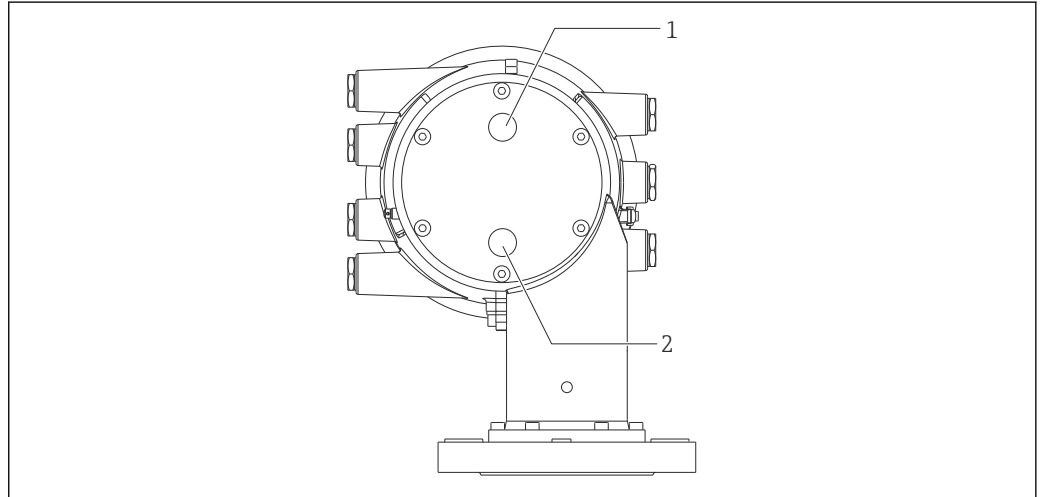

A0030103

32 Holes for cleaning nozzle and gas purging nozzle

- 1 Cleaning nozzle
- 2 Gas purging nozzle

Other combinations for relief valve, pressure gauge, cleaning nozzle, and gas purging nozzle

Cleaning nozzle and relief valve

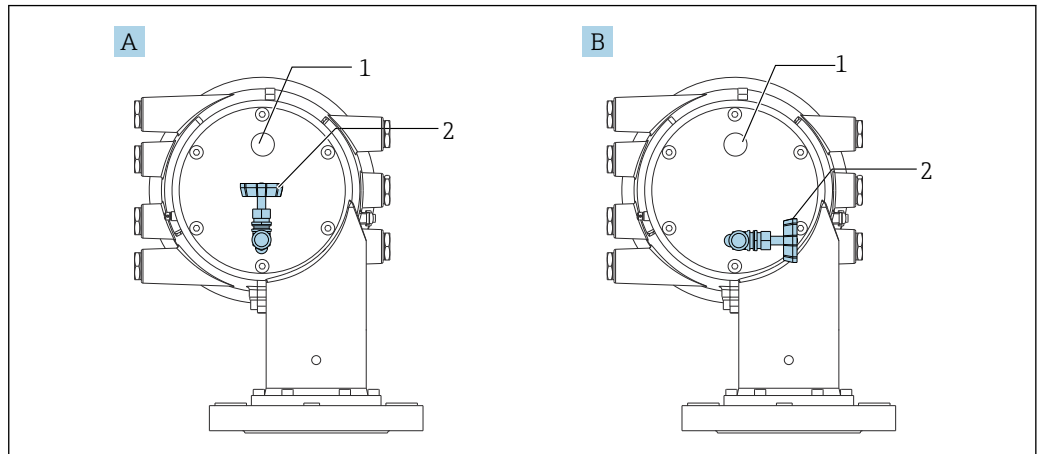

A0051205

33 Cleaning nozzle and relief valve

- A Standard version
- B 90°-degree rotation (optional)
- 1 Cleaning nozzle
- 2 Relief valve

Pressure gauge and gas purging nozzle

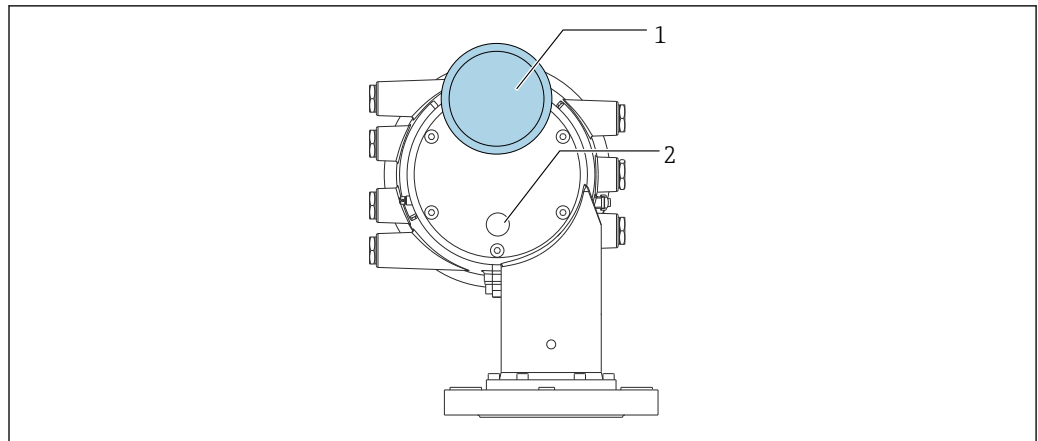

A0051270

 34 *Pressure gauge and gas purging nozzle*

- 1 *Pressure gauge*
- 2 *Gas purging nozzle*

Communication-specific accessories
WirelessHART adapter SWA70

- Is used for the wireless connection of field devices
- The WirelessHART adapter can be easily integrated into field devices and existing infrastructures, offers data protection and transmission safety and can be operated in parallel with other wireless networks



For details, see Operating Instructions BA00061S

Gauge Emulator, Modbus to BPM

- Using the protocol converter, it is possible to integrate a field device into a host system even if the field device does not know the communication protocol of the host system. Eliminates vendor lock-in for field devices.
- Field communication protocol (field device): Modbus RS485
- Host communication protocol (host system): Enraf BPM
- 1 measuring device per Gauge Emulator
- Separate power supply: 100 to 240 V_{AC}, 50 to 60 Hz, 0.375 A, 15 W
- Several approvals for the hazardous area

Gauge Emulator, Modbus to TRL/2

- Using the protocol converter, it is possible to integrate a field device into a host system even if the field device does not know the communication protocol of the host system. Eliminates vendor lock-in for field devices.
- Field communication protocol (field device): Modbus RS485
- Host communication protocol (host system): Saab TRL/2
- 1 measuring device per Gauge Emulator
- Separate power supply: 100 to 240 V_{AC}, 50 to 60 Hz, 0.375 A, 15 W
- Several approvals for the hazardous area

Service-specific accessories
Commubox FXA195 HART

For intrinsically safe HART communication with FieldCare via the USB interface



For details, see "Technical Information" TI00404F

Commubox FXA291

Connects Endress+Hauser field devices with a CDI interface (= Endress+Hauser Common Data Interface) and the USB port of a computer or laptop

Order number: 51516983



For details, see "Technical Information" TI00405C

DeviceCare SFE100

Configuration tool for HART, PROFIBUS and FOUNDATION Fieldbus field devices

DeviceCare is available for download at www.software-products.endress.com. You need to register in the Endress+Hauser software portal to download the application.



Technical Information TI01134S

FieldCare SFE500

FDT-based plant asset management tool

It can configure all smart field units in your system and helps you manage them. By using the status information, it is also a simple but effective way of checking their status and condition.



Technical Information TI00028S

System components
RIA15

Compact process display unit with very low voltage drop for universal use to display 4 to 20 mA/HART signals



Technical Information TI01043K

Tankvision Tank Scanner NXA820 / Tankvision Data Concentrator NXA821 / Tankvision Host Link NXA822

Inventory Management System with completely integrated software for operation via standard web browser



Technical Information TI00419G

Documentation

The following documentation types are available in the Downloads area of the Endress+Hauser website (www.endress.com/downloads):

-  For an overview of the scope of the associated Technical Documentation, refer to the following:
- *Device Viewer* (www.endress.com/deviceviewer): Enter the serial number from the nameplate
 - *Endress+Hauser Operations app*: Enter serial number from nameplate or scan matrix code on nameplate.

Technical Information (TI)	<p>Planning aid The document contains all the technical data on the device and provides an overview of the accessories and other products that can be ordered for the device.</p>
Brief Operating Instructions (KA)	<p>Guide that takes you quickly to the 1st measured value The Brief Operating Instructions contain all the essential information from incoming acceptance to initial commissioning.</p>
Operating Instructions (BA)	<p>The Operating Instructions contain all the information that is required in various phases of the life cycle of the device: from product identification, incoming acceptance and storage, to mounting, connection, operation and commissioning through to troubleshooting, maintenance and disposal.</p> <p>It also contains a detailed explanation of each individual parameter in the operating menu (except the Expert menu). The description is aimed at those who work with the device over the entire life cycle and perform specific configurations.</p>
Description of Device Parameters (GP)	<p>The Description of Device Parameters provides a detailed explanation of each individual parameter in the 2nd part of the operating menu: the Expert menu. It contains all the device parameters and allows direct access to the parameters by entering a specific code. The description is aimed at those who work with the device over the entire life cycle and perform specific configurations.</p>
Safety Instructions (XA)	<p>Depending on the approval, the following Safety Instructions (XA) are supplied with the device. They are an integral part of the Operating Instructions.</p> <p> The nameplate indicates the Safety Instructions (XA) that are relevant to the device.</p>
Installation instructions (EA)	<p>Installation Instruction are used to replace a faulty unit with a functioning unit of the same type.</p>

Registered trademarks

Modbus[®]

Registered trademark of SCHNEIDER AUTOMATION, INC.



71682617

www.addresses.endress.com
