

Brief Operating Instructions

Proservo NMS80

Tank Gauging



These Instructions are Brief Operating Instructions; they are not a substitute for the Operating Instructions pertaining to the device.

Detailed information about the device can be found in the Operating Instructions and the other documentation:

Available for all device versions via:

- Internet: www.endress.com/deviceviewer
- Smart phone/tablet: *Endress+Hauser Operations App*



A0023555

Table of contents

1	About this document	4
1.1	Symbols	4
1.2	Documentation	6
2	Basic safety instructions	7
2.1	Requirements for the personnel	7
2.2	Intended use	7
2.3	Workplace safety	7
2.4	Operational safety	8
2.5	Product safety	8
3	Product description	9
3.1	Product design	9
4	Incoming acceptance and product identification	10
4.1	Incoming acceptance	10
4.2	Product identification	10
4.3	Storage and transport	10
5	Installation	12
5.1	Requirements	12
5.2	Mounting of the device	16
6	Electrical connection	29
6.1	Terminal assignment	29
6.2	Connecting requirements	44
6.3	Ensuring the degree of protection	45
7	Commissioning	46
7.1	Operating methods	46
7.2	Terms related to tank measurement	49
7.3	Initial settings	50
7.4	Calibration	53
7.5	Configuration of the inputs	62
7.6	Linking measured values to tank variables	70
7.7	Configuration of the alarms (limit evaluation)	71
7.8	Configuration of the signal output	72

1 About this document

1.1 Symbols

1.1.1 Safety symbols

DANGER

This symbol alerts you to a dangerous situation. Failure to avoid this situation will result in serious or fatal injury.

WARNING

This symbol alerts you to a dangerous situation. Failure to avoid this situation can result in serious or fatal injury.

CAUTION

This symbol alerts you to a dangerous situation. Failure to avoid this situation can result in minor or medium injury.

NOTICE

This symbol contains information on procedures and other facts which do not result in personal injury.

1.1.2 Electrical symbols



Alternating current



Direct current and alternating current



Direct current



Ground connection

A grounded terminal which, as far as the operator is concerned, is grounded via a grounding system.

Protective earth (PE)

Ground terminals that must be connected to ground prior to establishing any other connections.

The ground terminals are located on the interior and exterior of the device:

- Interior ground terminal: protective earth is connected to the mains supply.
- Exterior ground terminal: device is connected to the plant grounding system.

1.1.3 Tool symbols



Phillips head screwdriver



Flat blade screwdriver



Torx screwdriver



Allen key



Open-ended wrench

1.1.4 Symbols for certain types of information and graphics

Permitted

Procedures, processes or actions that are permitted

Preferred

Procedures, processes or actions that are preferred

Forbidden

Procedures, processes or actions that are forbidden

Tip

Indicates additional information



Reference to documentation



Reference to graphic



Notice or individual step to be observed



Series of steps



Result of a step



Visual inspection



Operation via operating tool



Write-protected parameter

1, 2, 3, ...

Item numbers

A, B, C, ...

Views



Safety instructions

Observe the safety instructions contained in the associated Operating Instructions



Temperature resistance of the connection cables

Specifies the minimum value of the temperature resistance of the connection cables

1.2 Documentation

The following documentation types are available in the Downloads area of the Endress+Hauser website (www.endress.com/downloads):

 For an overview of the scope of the associated Technical Documentation, refer to the following:

- *Device Viewer* (www.endress.com/deviceviewer): Enter the serial number from the nameplate
- *Endress+Hauser Operations app*: Enter serial number from nameplate or scan matrix code on nameplate.

1.2.1 Technical Information (TI)

Planning aid

The document contains all the technical data on the device and provides an overview of the accessories and other products that can be ordered for the device.

1.2.2 Brief Operating Instructions (KA)

Guide that takes you quickly to the 1st measured value

The Brief Operating Instructions contain all the essential information from incoming acceptance to initial commissioning.

1.2.3 Operating Instructions (BA)

The Operating Instructions contain all the information that is required in various phases of the life cycle of the device: from product identification, incoming acceptance and storage, to mounting, connection, operation and commissioning through to troubleshooting, maintenance and disposal.

It also contains a detailed explanation of each individual parameter in the operating menu (except the **Expert** menu). The description is aimed at those who work with the device over the entire life cycle and perform specific configurations.

1.2.4 Description of Device Parameters (GP)

The Description of Device Parameters provides a detailed explanation of each individual parameter in the 2nd part of the operating menu: the **Expert** menu. It contains all the device parameters and allows direct access to the parameters by entering a specific code. The description is aimed at those who work with the device over the entire life cycle and perform specific configurations.

1.2.5 Safety Instructions (XA)

Depending on the approval, the following Safety Instructions (XA) are supplied with the device. They are an integral part of the Operating Instructions.

 The nameplate indicates the Safety Instructions (XA) that are relevant to the device.

1.2.6 Installation instructions (EA)

Installation Instruction are used to replace a faulty unit with a functioning unit of the same type.

2 Basic safety instructions

2.1 Requirements for the personnel

The personnel must fulfill the following requirements for its tasks:

- ▶ Trained, qualified specialists must have a relevant qualification for this specific function and task.
- ▶ Are authorized by the plant owner/operator.
- ▶ Are familiar with federal/national regulations.
- ▶ Before starting work, read and understand the instructions in the manual and supplementary documentation as well as the certificates (depending on the application).
- ▶ Follow instructions and comply with basic conditions.

2.2 Intended use

Application and measured materials

Depending on the version ordered, the measuring device can also measure potentially explosive, flammable, poisonous and oxidizing media.

Measuring devices for use in hazardous areas, in hygienic applications or in applications where there is an increased risk due to process pressure, are labeled accordingly on the nameplate.

To ensure that the measuring device remains in proper condition for the operation time:

- ▶ Only use the measuring device in full compliance with the data on the nameplate and the general conditions listed in the Operating Instructions and supplementary documentation.
- ▶ Check the nameplate to verify if the device ordered can be put to its intended use in the approval-related area (e.g. explosion protection, pressure vessel safety).
- ▶ Use the measuring device only for media against which the process-wetted materials are adequately resistant.
- ▶ If the measuring device is not operated at atmospheric temperature, compliance with the relevant basic conditions specified in the associated device documentation is absolutely essential.
- ▶ Protect the measuring device permanently against corrosion from environmental influences.
- ▶ Observe the limit values in the "Technical Information".

The manufacturer is not liable for damage caused by improper or non-designated use.

Residual risk

During operation the sensor may assume a temperature near the temperature of the measured material.

Danger of burns due to heated surfaces!

- ▶ For high process temperatures: Install protection against contact in order to prevent burns.

2.3 Workplace safety

For work on and with the device:

- ▶ Wear the required personal protective equipment according to federal/national regulations.

2.4 Operational safety

Risk of injury!

- ▶ Operate the device only if it is in proper technical condition, free from errors and faults.
- ▶ The operator is responsible for interference-free operation of the device.

Hazardous area

To eliminate danger to persons or the facility when the device is used in the hazardous area (e.g. explosion protection):

- ▶ Check the nameplate to verify if the device ordered can be put to its intended use in the hazardous area.
- ▶ Observe the specifications in the separate supplementary documentation that is an integral part of these instructions.

2.5 Product safety

This measuring device is designed in accordance with good engineering practice to meet state-of-the-art safety requirements, has been tested, and left the factory in a condition in which it is safe to operate. It meets the general safety standards and legal requirements.

NOTICE

Loss of degree of protection by opening of the device in humid environments

- ▶ If the device is opened in a humid environment, the degree of protection indicated on the nameplate is no longer valid. This may also impair the safe operation of the device.

2.5.1 CE mark

The measuring system meets the legal requirements of the applicable EU directives. These are listed in the corresponding EU Declaration of Conformity together with the standards applied.

The manufacturer confirms successful testing of the device by affixing to it the CE mark.

2.5.2 EAC conformity

The measuring system meets the legal requirements of the applicable EAC guidelines. These are listed in the corresponding EAC Declaration of Conformity along with the standards applied.

The manufacturer confirms successful testing of the device by affixing to it the EAC mark.

3 Product description

3.1 Product design

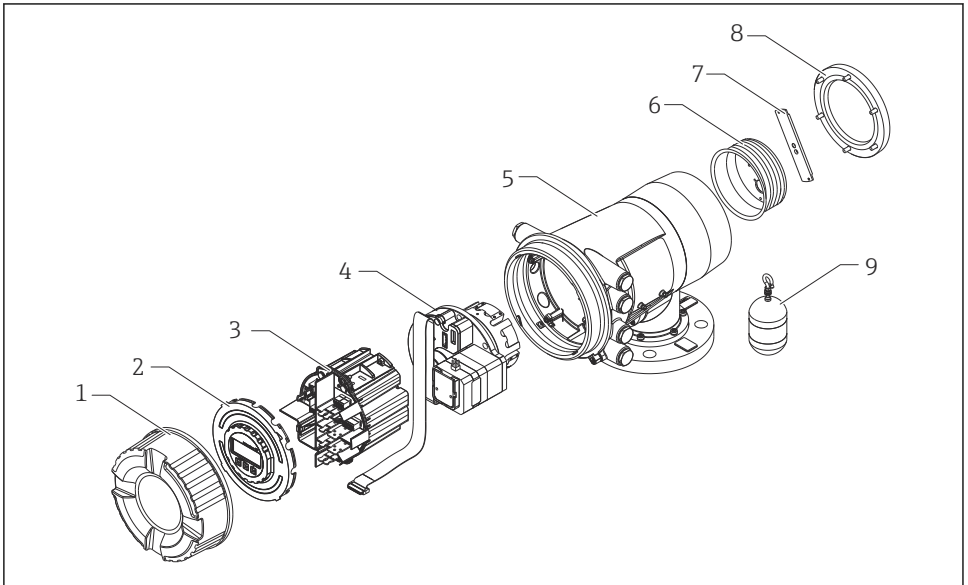

A0030105

 1 Configuration of NMS80

- 1 Front cover
- 2 Display
- 3 Modules
- 4 Sensor unit (detector unit and cable)
- 5 Housing
- 6 Wire drum
- 7 Bracket
- 8 Housing cover
- 9 Displacer

4 Incoming acceptance and product identification

4.1 Incoming acceptance

Upon receipt of the goods check the following:

- Are the order codes on the delivery note and the product sticker identical?
- Are the goods undamaged?
- Do the nameplate data match the ordering information on the delivery note?
- If required (see nameplate): Are the Safety Instructions (XA) enclosed?



If one of these conditions is not satisfied, contact your Endress+Hauser Sales Center.

4.2 Product identification

The following options are available for identification of the device:

- Nameplate specifications
- Enter the serial number from the nameplate in the *Device Viewer* (www.endress.com/deviceviewer): all the information about the device and an overview of the Technical Documentation supplied with the device are displayed.
- Enter the serial number on the nameplate into the *Endress+Hauser Operations App* or scan the 2-D matrix code (QR code) on the nameplate with the *Endress+Hauser Operations App*: all the information about the device and the technical documentation pertaining to the device is displayed.



For an overview of the scope of the associated Technical Documentation, refer to the following:

- *Device Viewer* (www.endress.com/deviceviewer): Enter the serial number from the nameplate
- *Endress+Hauser Operations app*: Enter serial number from nameplate or scan matrix code on nameplate.

4.2.1 Manufacturer address

Endress+Hauser Yamanashi Co., Ltd.

406-0846

862-1 Mitsukunugi, Sakaigawa-cho, Fuefuki-shi, Yamanashi

4.3 Storage and transport

4.3.1 Storage conditions

- Storage temperature: -50 to +80 °C (-58 to +176 °F)
- Store the device in its original packaging.

4.3.2 Transport

 CAUTION**Risk of injury**

- ▶ Transport the measuring device to the measuring point in its original packaging.
- ▶ Take into account the mass center of the device in order to avoid unintended tilting.
- ▶ Comply with the safety instructions, transport conditions for devices over 18 kg (39.6 lb) (IEC 61010).

5 Installation

5.1 Requirements

5.1.1 Mounting without a guide system

NMS8x is mounted on a nozzle of the tank roof without a guide system. Sufficient clearance inside the nozzle is necessary to allow the displacer to move without hitting the inner walls.

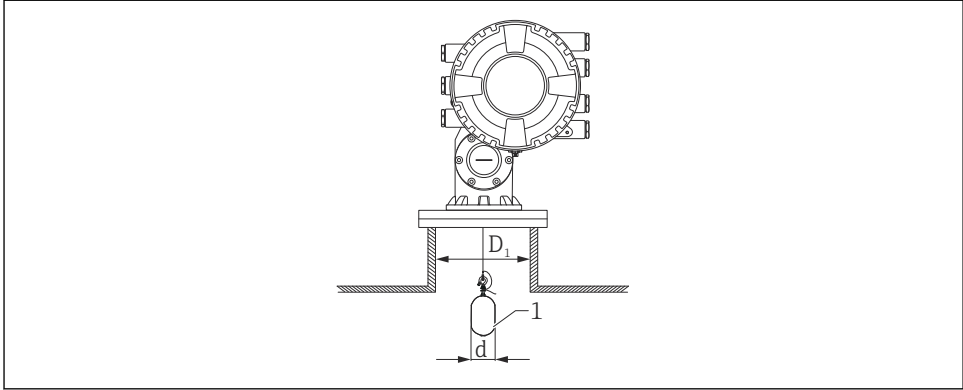

A0026734

2 No guide system

D_1 Inner diameter of the tank nozzle

d Diameter of the displacer

1 Displacer

5.1.2 Mounting with guide wires

It is also possible to guide the displacer with guide wires to prevent swinging.

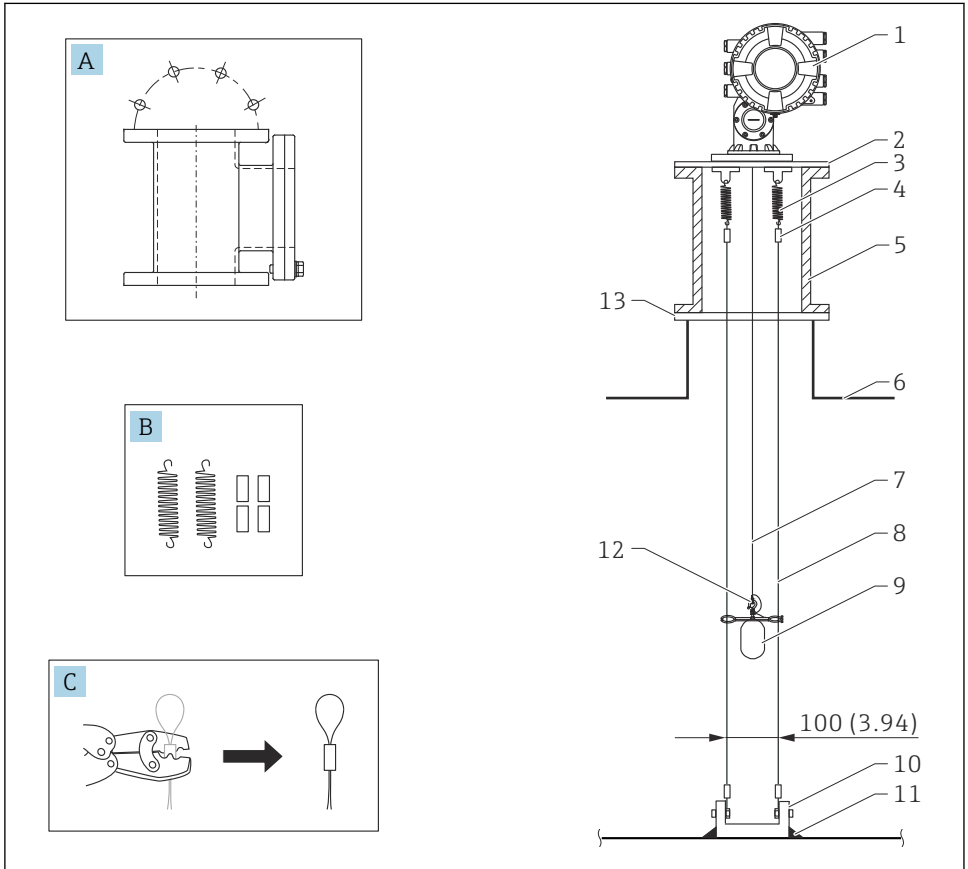

A0026819

3 Guide wire; dimensions mm (in)

No.	Description
A	Maintenance chamber
B	Spring and sleeve
C	Crimp tool and guide wire sleeve
1	NMS8x
2	3 to 6" Reducer plate (incl. guide wire option)
3	Spring, 304 (incl. guide wire option)

No.	Description
4	Sleeve,316 (incl. guide wire option)
5	Maintenance chamber
6	Tank
7	Measuring wire
8	Guide wire, 316 (incl. guide wire option)
9	Displacer with rings (incl. guide wire option)
10	Anchor hook plate, 304 (incl. guide wire option) <ul style="list-style-type: none"><li data-bbox="236 456 577 480">■ 100 mm (3.94 in) for D50 mm (1.97 in)<li data-bbox="236 480 577 504">■ 110 mm (4.33 in) for D70 mm (2.76 in)
11	Welding point
12	Wire ring, 316L
13	Flange

5.1.3 Guide ring dimension

The dimension of the guide ring is shown below.

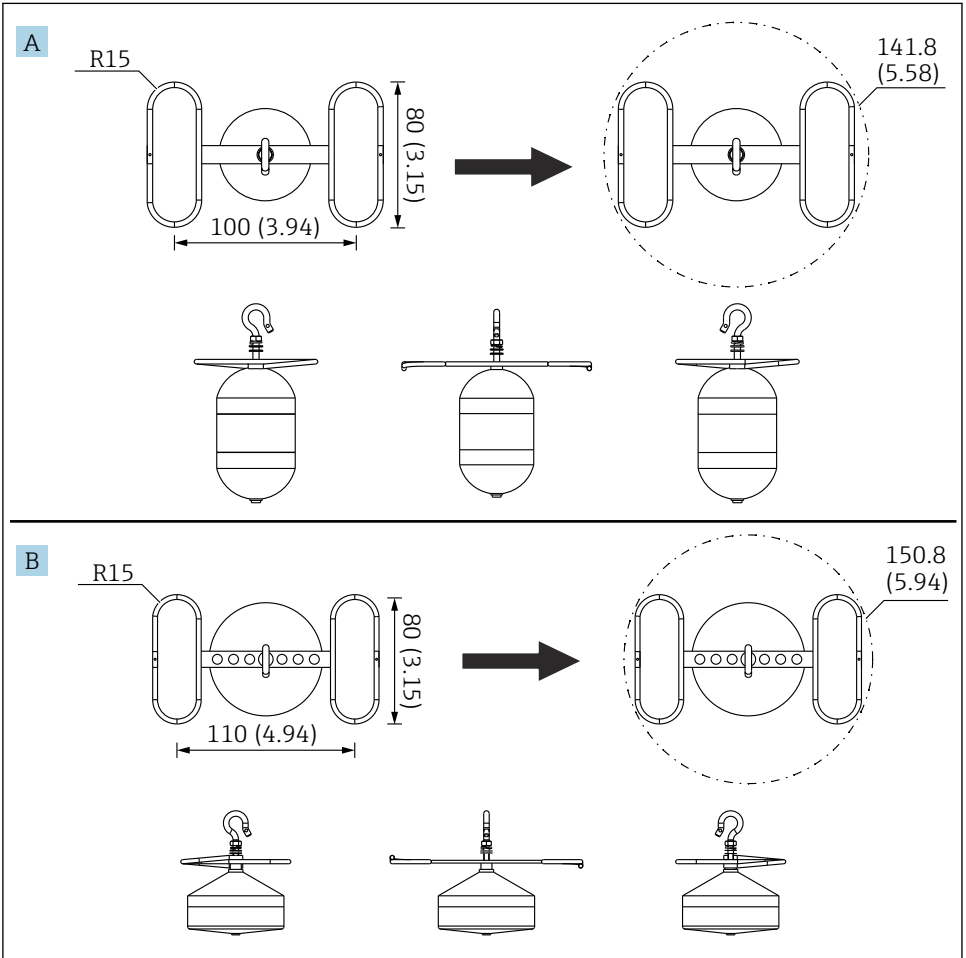

A0055638

4 Guide ring

A $\varnothing 50$ mm (1.97 in) 316L cylindrical displacer

B $\varnothing 70$ mm (2.76 in) 316L conical displacer

5.2 Mounting of the device

The NMS8x is delivered in two different packing styles depending on the mounting method of the displacer.

- For the all-in-one method, the displacer is mounted on the measuring wire of NMS8x.
- For the displacer shipped separately method, it is necessary to install the displacer on the measuring wire inside NMS8x.

5.2.1 Available installations

The following installation procedures are available for NMS8x.

- Mounting without guide system
- Mounting with stilling well
- Mounting with guide wire

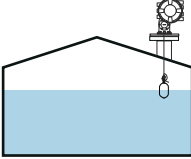
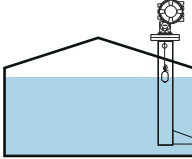
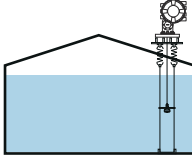
Mounting options	Without guide system (Free-space mounting)	With stilling well	With guide wire
Type of tanks			
Type of installations	<ul style="list-style-type: none"> ■ All-in one ■ Displacer shipped separately ■ Displacer installation through calibration window 	<ul style="list-style-type: none"> ■ All-in one ■ Displacer shipped separately ■ Displacer installation through calibration window 	Displacer shipped separately

5.2.2 Verification of displacer and wire drum

Prior to installation of NMS8x, confirm that the serial numbers of displacer and the wire drum match with those printed to the label attached on the housing.

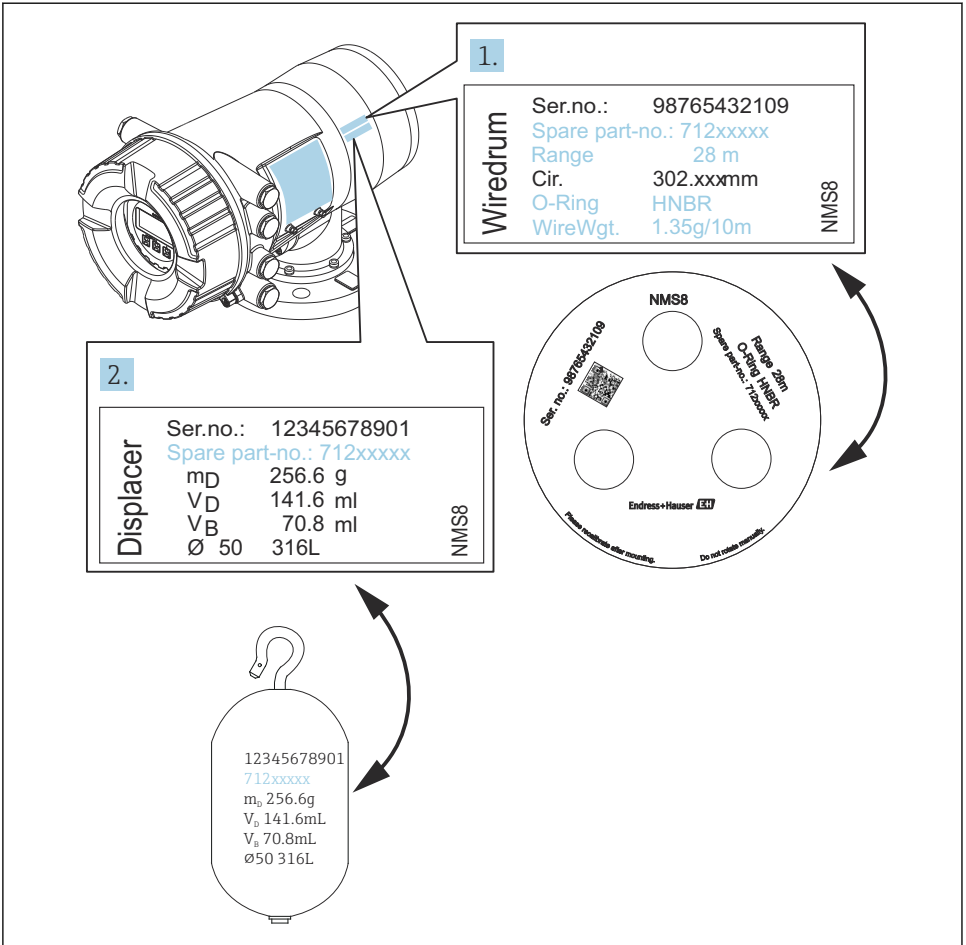

A0030106

5 Verification of displacer and wire drum

5.2.3 Installation for all-in-one method

The device can be delivered by all-in-one method.

i Displacer is shipped separately according to the following specifications.

- 316L 30 mm (1.18 in) displacer
- 316L 110 mm (4.33 in) displacer
- PTFE 30 mm (1.18 in) displacer
- PTFE 50 mm (1.97 in) displacer
- Guide wire assembly
- Cleaned from oil + grease option

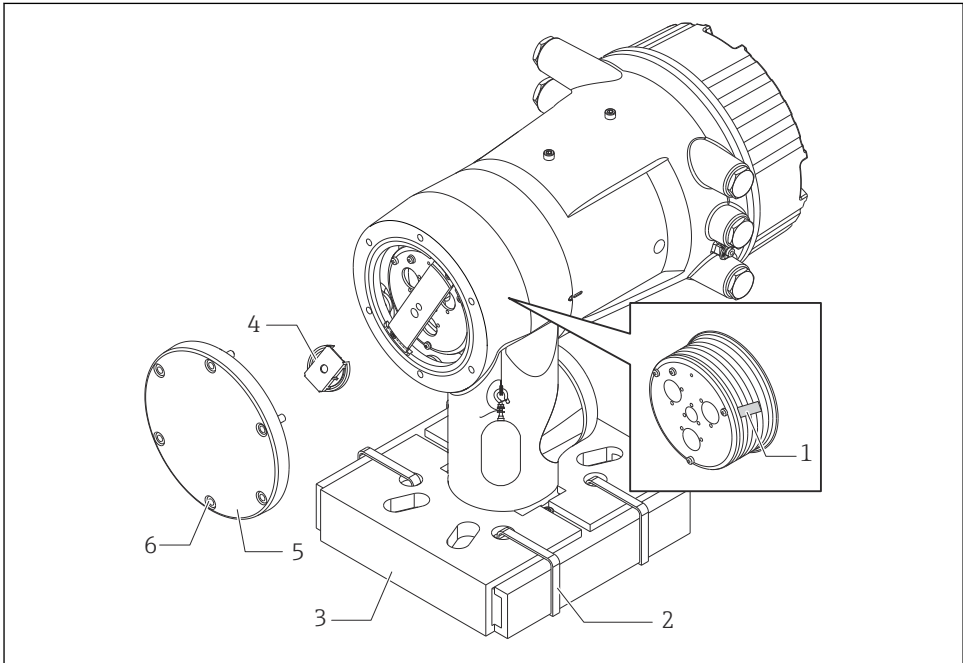

A0030108

6 Removing packing materials



- 1 Tape
- 2 Fixing band
- 3 Displacer holder
- 4 Wire drum stopper
- 5 Drum housing cover
- 6 Screws and bolts

Procedures	Notes
<ol style="list-style-type: none"> 1. Hold the gauge so that it stays horizontal against the flange. 2. Cut the fixing bands [2]. 3. Remove the displacer holder [3] and packing material of the displacer. 	<ul style="list-style-type: none"> ▪ Perform these steps before mounting NMS8x on the nozzle. ▪ Do not tilt NMS8x after removing the displacer holder.
<ol style="list-style-type: none"> 4. Mount NMS8x on the nozzle. 	<ul style="list-style-type: none"> ▪ Make sure that the measuring wire hangs vertically. ▪ Confirm that there are no kinks or other defects in the measuring wire.
<ol style="list-style-type: none"> 5. Remove screws and M6 bolts [6] (M10 bolts for stainless steel housing) to remove the drum housing cover [5]. 6. Loosen two screws and remove the wire drum stopper [4]. 	<p>Be sure not to lose the O-ring and the fixing bolts for the cover of the drum housing.</p>
<ol style="list-style-type: none"> 7. Remove the tape [1] from the wire drum carefully. 	<ul style="list-style-type: none"> ▪ Remove the tape by hand to avoid damaging the wire drum. ▪ Make sure that the measuring wire is wound so that it fits correctly in the grooves.
<ol style="list-style-type: none"> 8. Mount the drum housing cover. 	<p>Confirm that the O-ring is in the drum housing cover.</p>
<ol style="list-style-type: none"> 9. Turn on the power of NMS8x. 	<p> Sensor, reference, and drum calibration steps are not required because they are all performed prior to delivery.</p>

5.2.4 Installation for displacer shipped separately method

It is necessary to remove the wire drum from NMS8x, remove the tape on the wire drum, mount the wire drum in the drum housing, and install the displacer on the measuring wire.

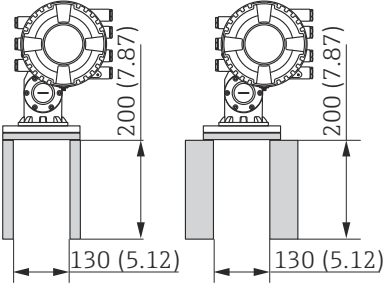
Use blocks or a pedestal to secure NMS8x and provide an environment where electrical power can be supplied to NMS8x.

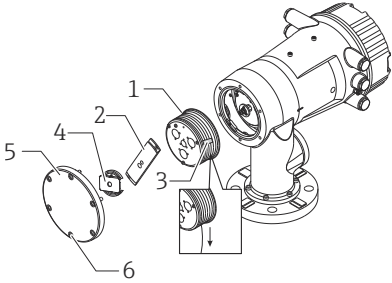
Procedures	Figures
<ol style="list-style-type: none"> 1. Secure NMS8x on the blocks or pedestal. 2. Confirm that there is enough space under NMS8x. <p> Be careful not to drop NMS8x.</p>	 <p style="text-align: center;">Dimensions mm (in)</p>
<ol style="list-style-type: none"> 3. Remove screws and M6 bolts [6] (M10 bolts for stainless steel housing). 4. Remove the wire drum cover [5], wire drum stopper [4], and the bracket [2]. 5. Remove the wire drum [1] from the drum housing. 6. Remove the tape [3] on the wire drum. 7. Unwind the measuring wire approximately 250 mm (9.84 in) so that the wire ring is positioned under the flange. 8. Mount the wire drum on NMS8x. 9. Mount the bracket. <p> <ul style="list-style-type: none"> ▪ Take special care to not hit the wire drum against the housing due to strong magnet force. ▪ Handle the measuring wire with care. It may kink. ▪ Be sure that the wire is wound correctly in the grooves. </p>	 <p style="text-align: right; font-size: small;">A0030109</p>

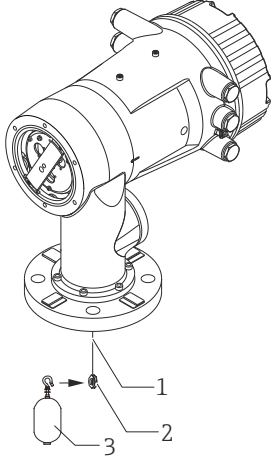
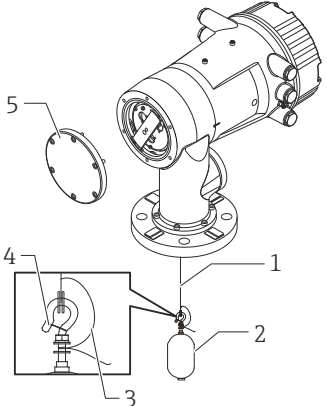
Procedures	Figures
<p>10. Hook the displacer [3] on the ring [2].</p> <p>i</p> <ul style="list-style-type: none"> ▪ Be sure that the wire is wound correctly in the grooves. ▪ If not, remove the displacer and the wire drum, and repeat step 7. 	 <p style="text-align: right;">A0030110</p>
<p>11. Turn on the power of NMS8x.</p> <p>12. Perform sensor calibration</p> <p>13. Secure the displacer [2] to the measuring wire [1] using the securing wire [4].</p> <p>14. Install the ground wire [3] of the displacer (for details of displacer ground wire installation → 26).</p> <p>15. Perform reference calibration.</p> <p>16. Turn off the power.</p> <p>17. Mount the wire drum cover [5].</p> <p>i</p> <ul style="list-style-type: none"> ▪ For sensor calibration, → 55 ▪ For reference calibration, → 58. 	 <p style="text-align: right;">A0030111</p>

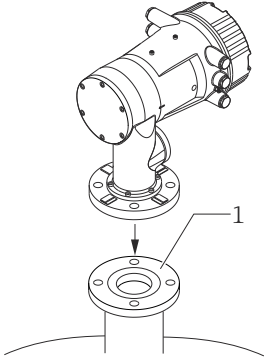



Procedures	Figures
<p>18. Mount NMS8x on the tank nozzle [1].</p> <p>19. Confirm that the displacer does not touch the inner wall of the nozzle.</p> <p>20. Turn on the power.</p> <p>21. Perform drum calibration.</p> <p>i For drum calibration, → 📖 59</p>	 <p>A technical line drawing illustrating the installation of the NMS8x sensor. The sensor, a cylindrical device with a mounting bracket, is positioned above a circular flange. A callout line labeled '1' points to the nozzle assembly below the flange. Below the flange is another nozzle assembly, which is the tank nozzle to be mounted. The drawing shows the sensor's position relative to the nozzle and the flange.</p> <p>A0030112</p>

5.2.5 Installation through the calibration window



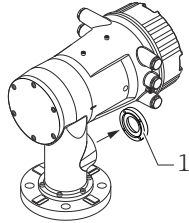

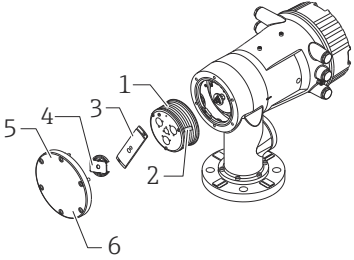

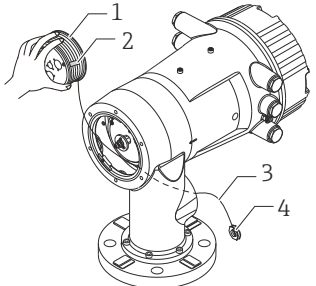
In the case of a 50 mm (1.97 in) diameter displacer, the displacer can be installed through the calibration window.

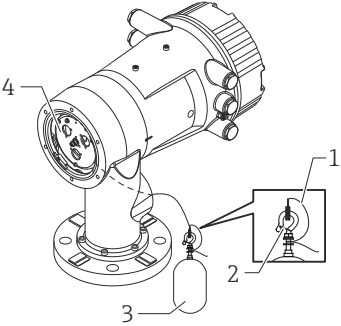
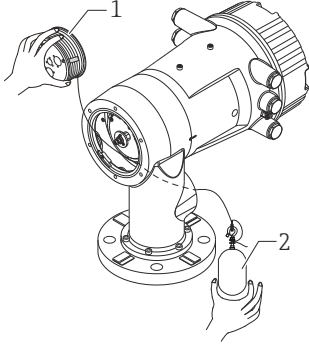
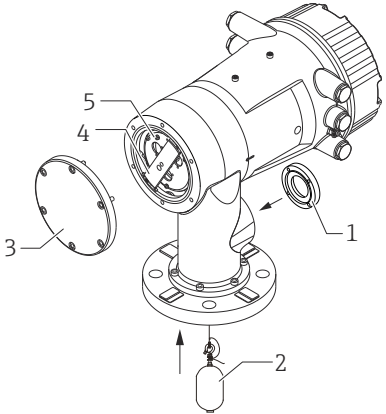

It is only possible to install the following displacers through the calibration window:
50 mm SUS, 50 mm alloy C, 50 mm PTFE

Procedures	Figures
<p>1. Remove the calibration window cover [1].</p>	 <p style="text-align: right;">A0030113</p>
<p>2. Remove M6 bolts and screws [6] (M10 bolts for stainless steel housing).</p> <p>3. Remove the cover [5], wire drum stopper [4], and the bracket [3].</p> <p>4. Remove the wire drum [1] from the drum housing.</p> <p>5. Remove the tape [2] that is securing the wire.</p> <p> Handle the measuring wire with care. It may kink.</p>	 <p style="text-align: right;">A0030114</p>
<p>6. Holding the wire drum [1] with one hand, unwind the measuring wire [3] approximately 500 mm (19.69 in).</p> <p>7. Secure the wire [3] temporarily with the tape [2].</p> <p>8. Insert the wire ring [4] into the drum housing.</p> <p>9. Pull the wire ring out through the calibration window.</p> <p> Handle the measuring wire with care.</p>	 <p style="text-align: right;">A0030115</p>

Procedures	Figures
<p>10. Insert the wire drum [4] temporarily into the drum housing.</p> <p>11. Hook the displacer [3] on the wire ring.</p> <p>12. Secure the displacer to the measuring wire using the securing wire [2].</p> <p>13. Install the ground wire [1] for the displacer (for details of displacer ground wire installation → 26).</p> <p>i Take special care to not hit the wire drum against the housing due to strong magnet force.</p> <p>▪ Handle the measuring wire with care. It may kink.</p>	 <p style="text-align: right;">A0030116</p>
<p>14. Remove the wire drum from the drum housing and unwind the measuring wire approximately 500 mm (19.69 in).</p> <p>15. Hold the wire drum [1] up and place the displacer [2] into the calibration window.</p> <p>16. Hold the displacer at the center of the calibration window.</p> <p>17. Hold the other hand (wire drum) up to add tension to the measuring wire in order not to drop the displacer rapidly.</p>	 <p style="text-align: right;">A0030117</p>
<p>18. Let go of the displacer [2].</p> <p>19. Remove the tape from the wire drum [5].</p> <p>20. Insert the wire drum into the drum housing.</p> <p>21. Mount the bracket [4].</p> <p>i Be sure that the wire is wound correctly in the grooves.</p> <p>22. Turn on the power of NMS8x and move the displacer up using the Move displacer wizard → 54 until the wire ring can be seen in the calibration window.</p> <p>i Confirm that there are no kinks or other defects in the measuring wire.</p> <p>▪ Confirm that the displacer does not touch the inner wall of the nozzle.</p> <p>23. Perform sensor calibration.</p>	 <p style="text-align: right;">A0030118</p>

Procedures	Figures
<p> For sensor calibration, →  55</p> <p>24. Perform reference calibration.</p> <p> For reference calibration, →  58.</p> <p>25. Mount the drum housing cover [3] and the calibration window cover [1].</p> <p>26. Perform drum calibration.</p> <p> For drum calibration, →  59</p>	

Displacer ground wire installation

Depending on the application and Ex requirements, electrical grounding of the displacer is required. There are different procedures depending on the displacer type, which are described below.

 For details of displacer installation →  16

Standard displacer installation

1. Mount the displacer [3] on the wire ring [1].
2. Wind the securing wire [4] on the wire hook.
3. Wind the ground wire [2] between the washers [5] twice.
 - ↳ If grounding is not required for non-explosion-proof applications, skip this step.
4. Secure the nut [6] with a wrench [7].

This completes the displacer installation procedure.

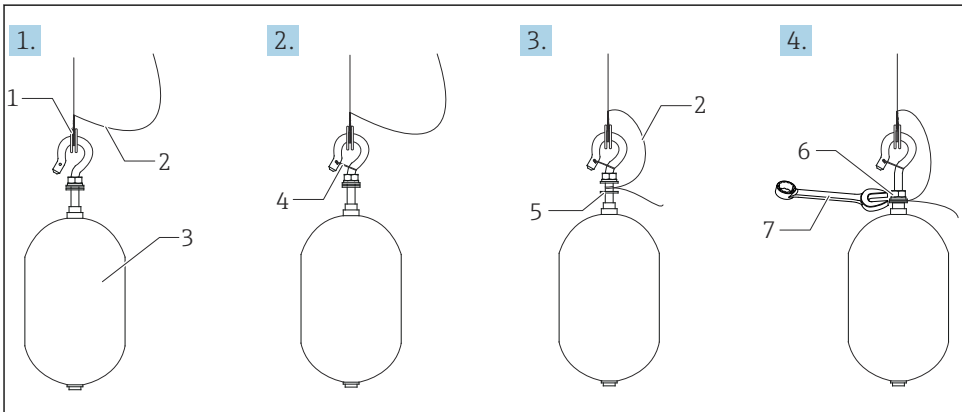

7 Displacer installation

- 1 Wire ring
- 2 Ground wire
- 3 Displacer
- 4 Securing wire
- 5 Washer
- 6 Nut
- 7 Wrench

PTFE displacer installation

1. Remove the screw [1] using a flathead screwdriver.
2. Mount the displacer [4] on the Teflon ring [2].

3. Remove the PFA covered wire approximately 3.5 to 4.0 mm (0.14 to 0.16 in) for conductivity.
 - ↳ **PTFE wire:** Install the ground wire [6] onto the displacer from the wire insertion slot [3] until the ground wire touches to the wall of the screw hole [5].
 - SUS wire:** Install the ground wire [6] onto the displacer from the wire insertion slot [3] until the ground wire touches to the wall of the screw hole [5]. Then install the ground wire 10 mm (0.39 in) farther.
4. Install the ground wire [6] onto the displacer from the wire insertion slot [3] until the ground wire contacts to the wall of the screw hole [5].
5. Tighten the screw [1].
 - ↳ Hold the ground wire with finger tips so that the wire does not come out from the slot.
6. Lift the displacer using a screwdriver and confirm that the ground wire does not come out from the slot.

This completes the PTFE displacer installation.

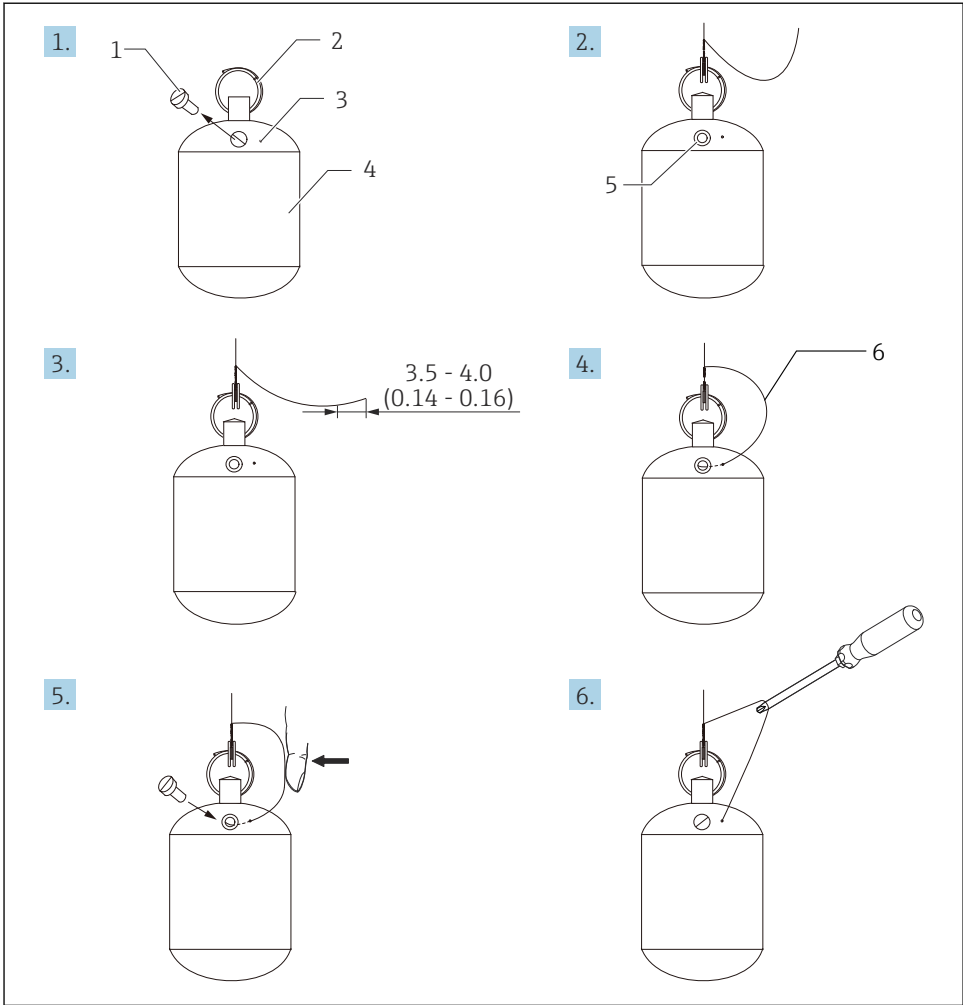

A0028696

8 PTFE displacer installation; dimensions mm (in)

- 1 Screw
- 2 PFA covered ring
- 3 Wire insertion slot
- 4 Displacer
- 5 Screw hole
- 6 Ground wire

6 Electrical connection

6.1 Terminal assignment

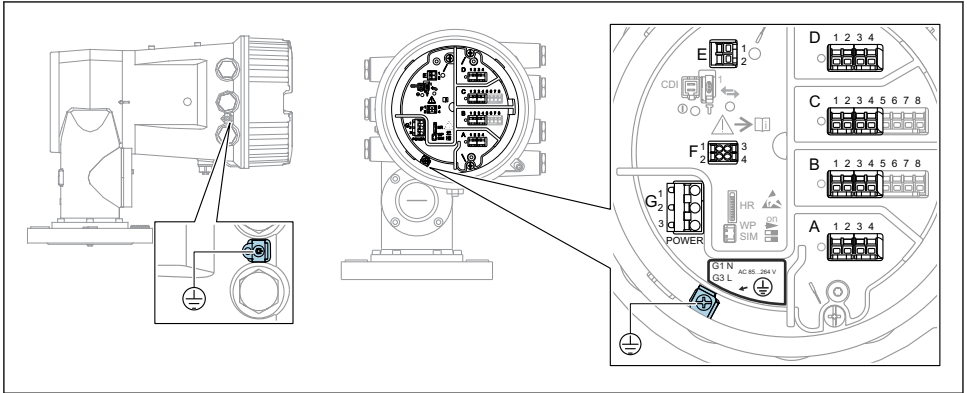

A0026905

 9 Terminal compartment (typical example) and ground terminals



Housing thread

The threads of the electronics and connection compartment can be coated with an anti-friction coating.

The following applies for all housing materials:

 **Do not lubricate the housing threads.**

Terminal area A/B/C/D (slots for I/O modules)

Module: Up to four I/O modules, depending on the order code

- Modules with four terminals can be in any of these slots.
- Modules with eight terminals can be in slot B or C.



The exact assignment of the modules to the slots is dependent on the device version
→  34.

Terminal area E

Module: HART Ex i/IS interface

- E1: H+
- E2: H-

Terminal area F

Remote display

- F1: V_{CC} (connect to terminal 81 of the remote display)
- F2: Signal B (connect to terminal 84 of the remote display)
- F3: Signal A (connect to terminal 83 of the remote display)
- F4: Gnd (connect to terminal 82 of the remote display)

Terminal area G (for High voltage AC power supply and Low voltage AC power supply)

- G1: N
- G2: not connected
- G3: L

Terminal area G (for Low voltage DC power supply)

- G1: L-
- G2: not connected
- G3: L+

Terminal area: Protective ground

Module: Protective ground connection (M4 screw)



A0018339

10 Terminal area: Protective ground

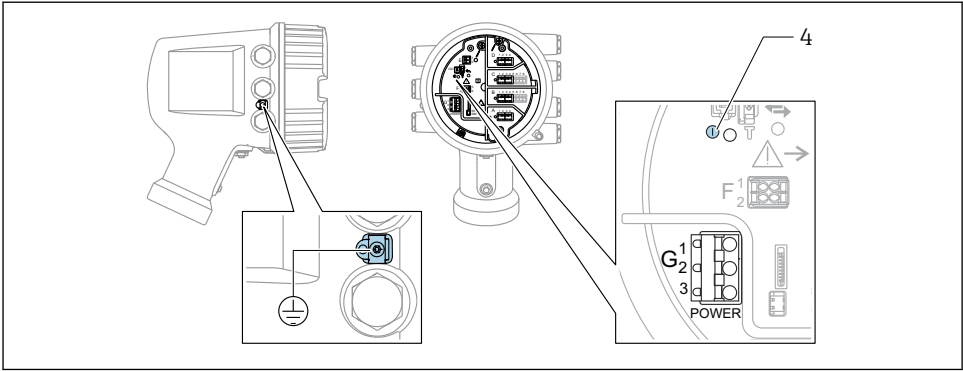
6.1.1 Power supply

A0033413

- G1 N
- G2 not connected
- G3 L
- 4 Green LED: indicates power supply



The supply voltage is also indicated on the nameplate.

Supply voltage**High voltage AC power supply:**

Operational value:

100 to 240 V_{AC} (- 15 % + 10 %) = 85 to 264 V_{AC}, 50/60 Hz

Low voltage AC power supply:

Operational value:

 $65 V_{AC} (-20\% + 15\%) = 52 \text{ to } 75 V_{AC}, 50/60 \text{ Hz}$ **Low voltage DC power supply:**

Operational value:

 $24 \text{ to } 55 V_{DC} (-20\% + 15\%) = 19 \text{ to } 64 V_{DC}$ **Power consumption**

Maximum power varies depending on the configuration of the modules. The value shows maximum apparent power, select the applicable cables accordingly. The actual consumed effective power is 12 W.

High voltage AC power supply:

28.8 VA

Low voltage AC power supply:

21.6 VA

Low voltage DC power supply:

13.4 W

6.1.2 Remote display and operating module DKX001

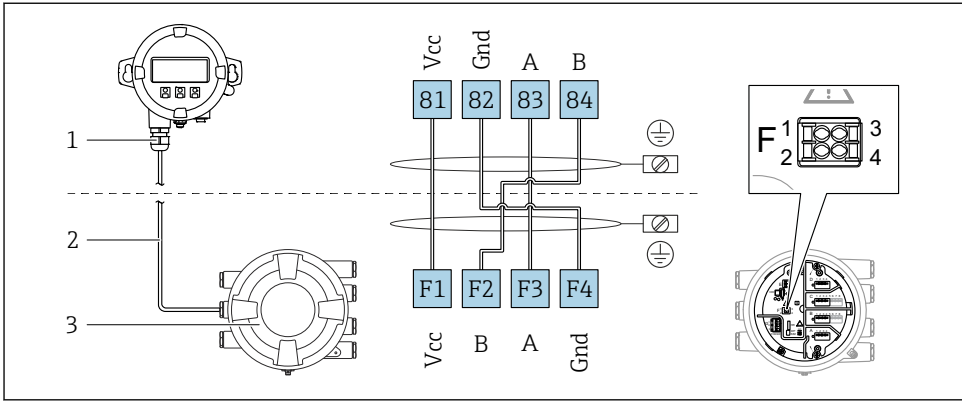

A0037025

11 Connection of the remote display and operating module DKX001 to the Tank Gauging device (NMR8x, NMS8x or NRF8x)

- 1 Remote display and operating module
- 2 Connecting cable
- 3 Tank Gauging device (NMR8x, NMS8x or NRF8x)

i The remote display and operating module DKX001 is available as an accessory. For details refer to SDO1763D.

- i**
 - The measured value is indicated on the DKX001 and on the local display and operating module simultaneously.
 - The operating menu cannot be accessed on both modules at the same time. If the operating menu is entered in one of these modules, the other module is automatically locked. This locking remains active until the menu is closed in the first module (back to measured value display).

6.1.3 HART Ex i/IS interface

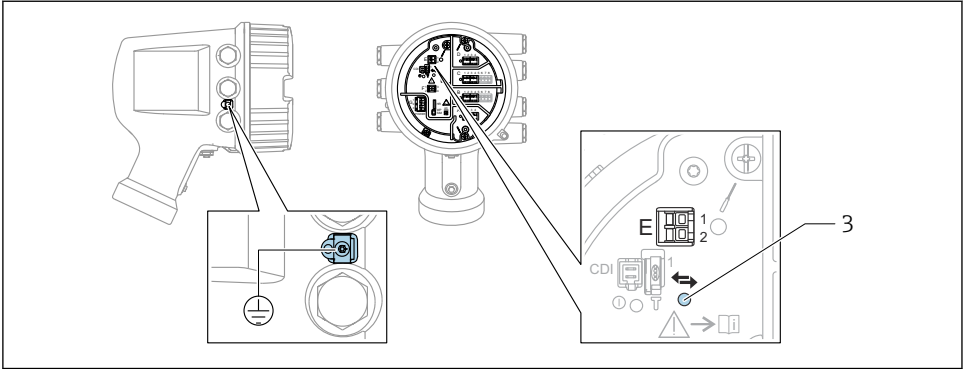

A0033414

E1 H+

E2 H-

3 Orange LED: indicates data communication



This interface always operates as the main HART master for connected HART slave transmitters. The Analog I/O modules, on the other hand, can be configured as a HART master or slave → [37](#) → [40](#).

6.1.4 Slots for I/O modules

The terminal compartment contains four slots (A, B, C and D) for I/O modules. Depending on the device version (ordering features 040, 050 and 060) these slots contain different I/O modules. The slot assignment for the device at hand is indicated on a label attached to the back cover of the display module.

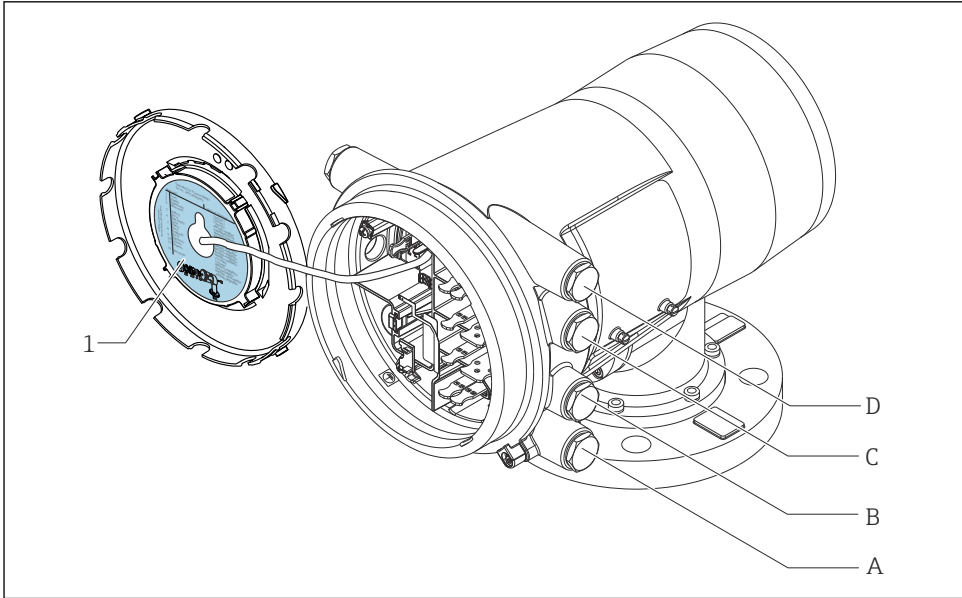

A0030119

- 1 Label showing (among other things) the modules in the slots A to D.
- A Cable entry for slot A
- B Cable entry for slot B
- C Cable entry for slot C
- D Cable entry for slot D

6.1.5 Terminals of the "Modbus" module, "V1" module or "WM550" module

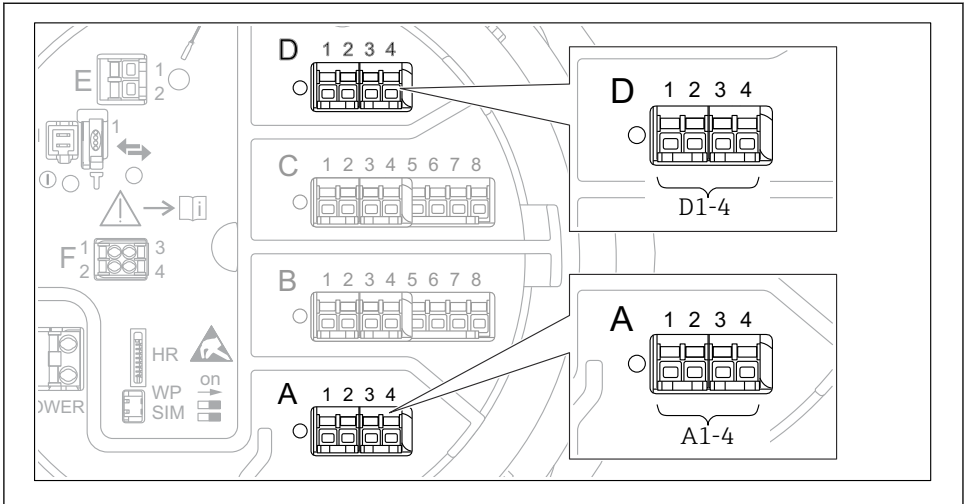

A0031200

12 Designation of the "Modbus", "V1" or "WM550" modules (examples); depending on the device version these modules may also be in slot B or C.

Depending on the device version, the "Modbus" and/or "V1" or "WM550" module may be in different slots of the terminal compartment. In the operating menu the "Modbus" and "V1" or "WM550" interfaces are designated by the respective slot and the terminals within this slot: **A1-4, B1-4, C1-4, D1-4**.

Terminals of the "Modbus" module

Designation of the module in the operating menu: **Modbus X1-4**; (X = A, B, C or D)

- X1¹⁾
 - Terminal name: S
 - Description: Cable shielding connected via a capacitor to EARTH
- X2¹⁾
 - Terminal name: 0V
 - Description: Common reference
- X3¹⁾
 - Terminal name: B-
 - Description: Non-inverting signal line
- X4¹⁾
 - Terminal name: A+
 - Description: Inverting signal line

1) Here, "X" stands for one of the slots "A", "B", "C", or "D".

Terminals of the "V1" and "WM550" module

Designation of the module in the operating menu: **V1 X1-4** or **WM550 X1-4**; (X = A, B, C or D)

- X1 ²⁾
 - Terminal name: S
 - Description: Cable shielding connected via a capacitor to EARTH
- X2 ¹⁾
 - Terminal name: -
 - Description: not connected
- X3 ¹⁾
 - Terminal name: B-
 - Description: Protocol loop signal -
- X4 ¹⁾
 - Terminal name: A+
 - Description: Protocol loop signal +

2) Here, "X" stands for one of the slots 'A', 'B', 'C', or 'D'.

6.1.6 Connection of the "Analog I/O" module for passive usage



- In the passive usage the supply voltage for the communication line must be supplied by an external source.
- The wiring must be in accordance with the intended operating mode of the Analog I/O module; see the drawings below.

"Operating mode" = "4..20mA output" or "HART slave +4..20mA output"

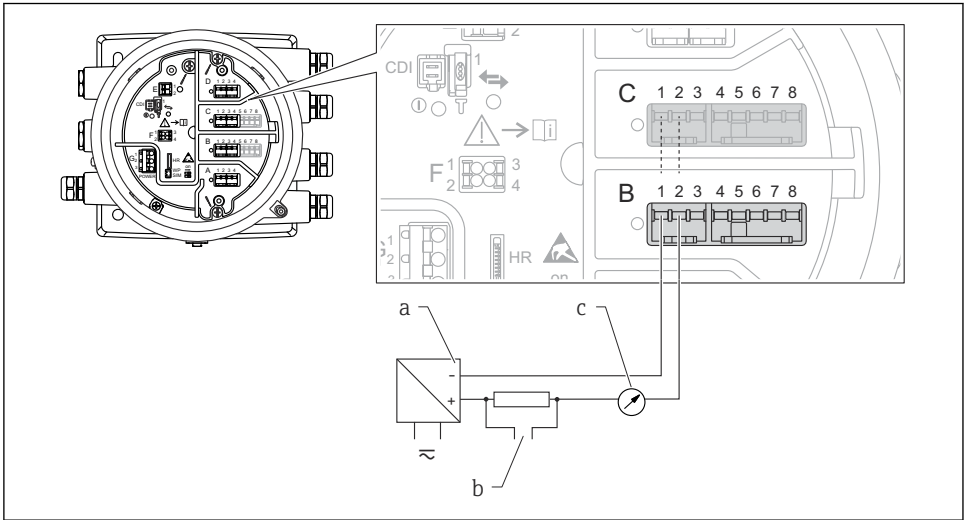

A0027931

13 Passive usage of the Analog I/O module in the output mode

- a Power supply
- b HART signal output
- c Analog signal evaluation

"Operating mode" = "4..20mA input" or "HART master+4..20mA input"

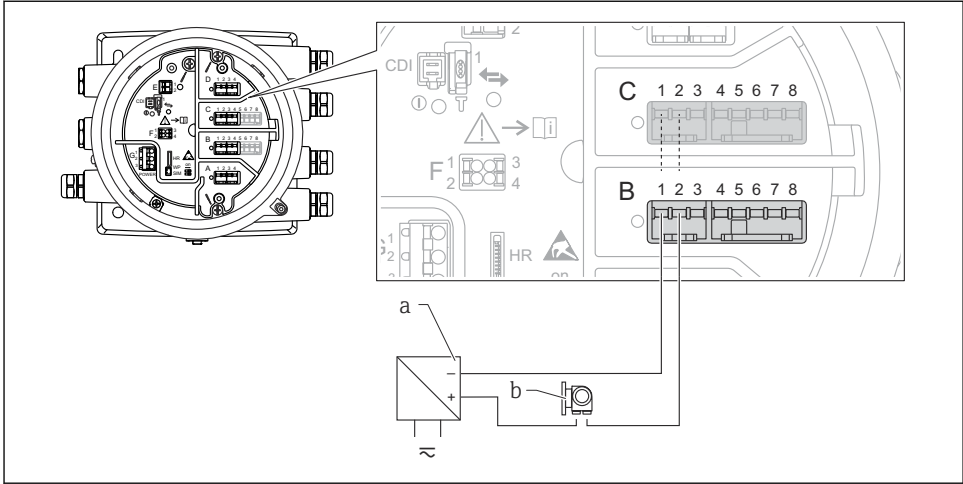

A0027933

14 *Passive usage of the Analog I/O module in the input mode*

- a* Power supply
- b* External device with 4...20mA and/or HART signal output

"Operating mode" = "HART master"

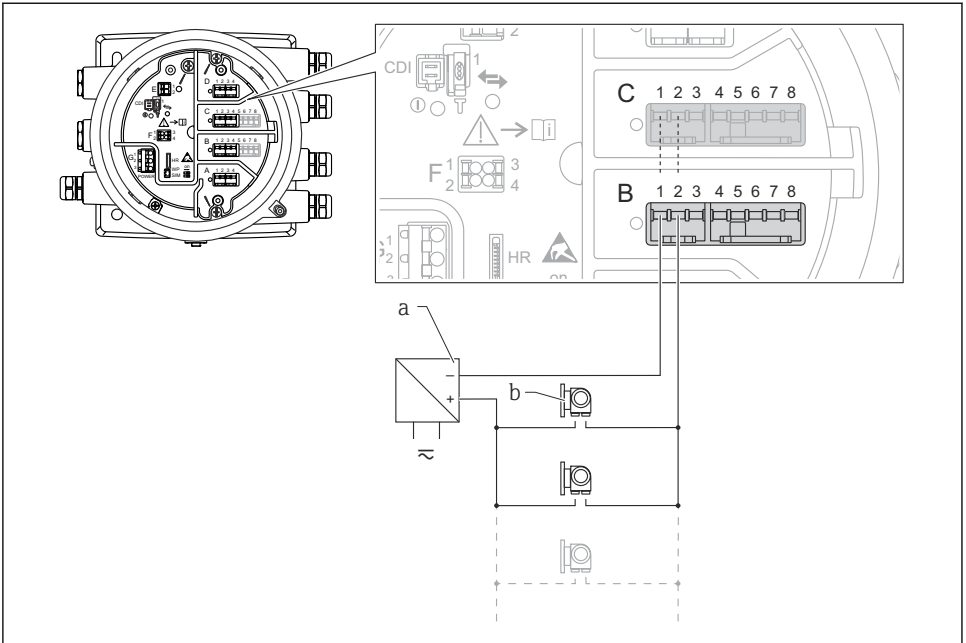

A0027934

15 Passive usage of the Analog I/O module in the HART master mode

- a Power supply
- b Up to 6 external devices with HART signal output

6.1.7 Connection of the "Analog I/O" module for active usage

- i** In the active usage the supply voltage for the communication line is supplied by the device itself. There is no need of an external power supply.
- The wiring must be in accordance with the intended operating mode of the Analog I/O module; see the drawings below.
- i** Maximum current consumption of the connected HART devices: 24 mA (i.e. 4 mA per device if 6 devices are connected).
- Output voltage of the Ex-d module: 17.0 V@4 mA to 10.5 V@22 mA
- Output voltage of the Ex-ia module: 18.5 V@4 mA to 12.5 V@22 mA

"Operating mode" = "4..20mA output" or "HART slave +4..20mA output"

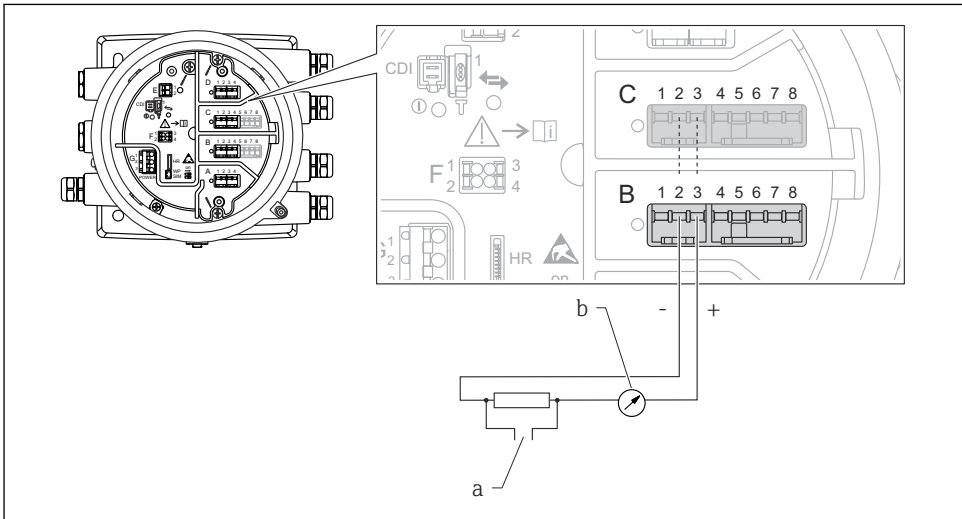

A0027932

16 Active usage of the Analog I/O module in the output mode

- a* HART signal output
- b* Analog signal evaluation

"Operating mode" = "4...20mA input" or "HART master+4...20mA input"

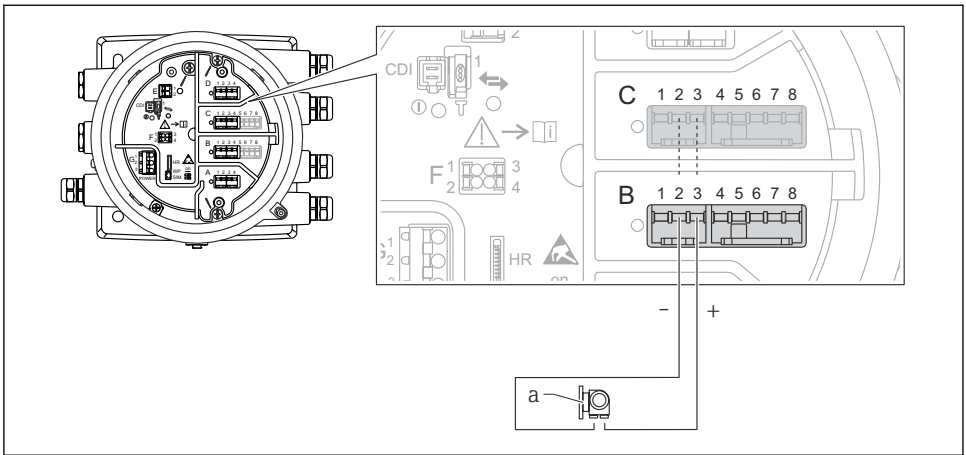

A0027935

17 Active usage of the Analog I/O module in the input mode

a External device with 4...20mA and/or HART signal output

"Operating mode" = "HART master"

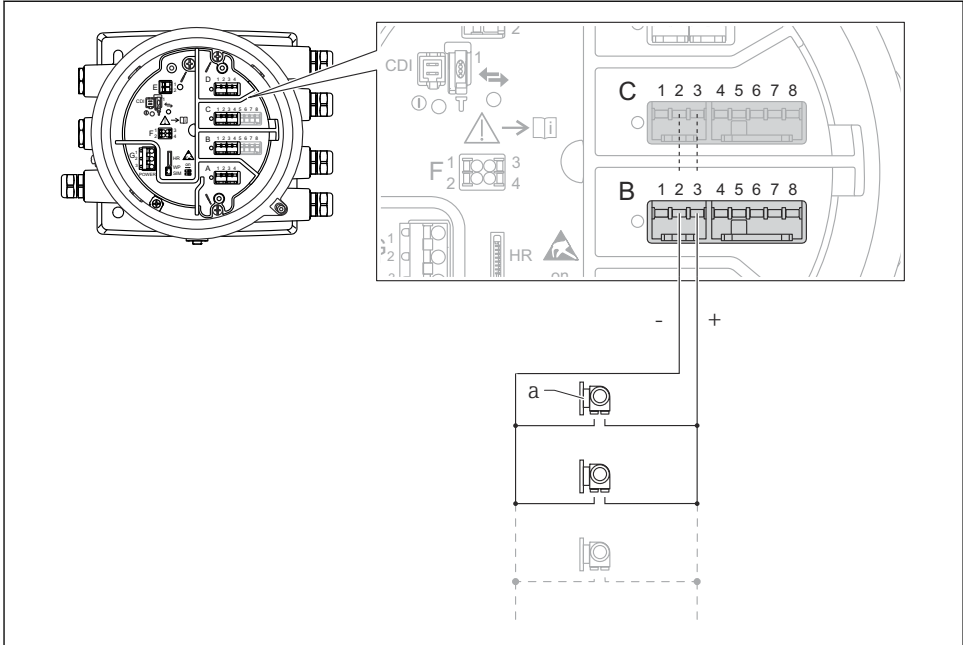

A0027936

18 Active usage of the Analog I/O module in the HART master mode

a Up to 6 external devices with HART signal output

i The maximum current consumption for the connected HART devices is 24 mA (i.e. 4 mA per device if 6 devices are connected).

6.1.8 Connection of a RTD

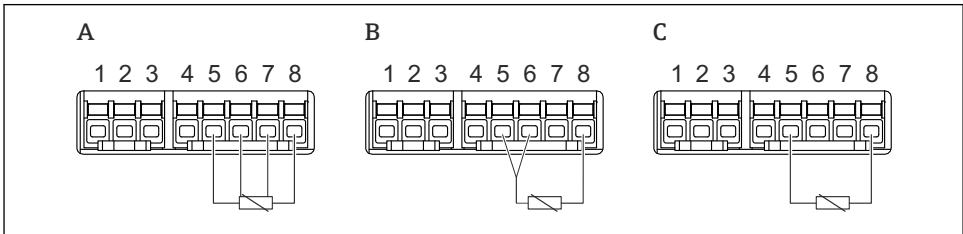

A0026371

A 4-wire RTD connection

B 3-wire RTD connection

C 2-wire RTD connection

6.1.9 Terminals of the "Digital I/O" module

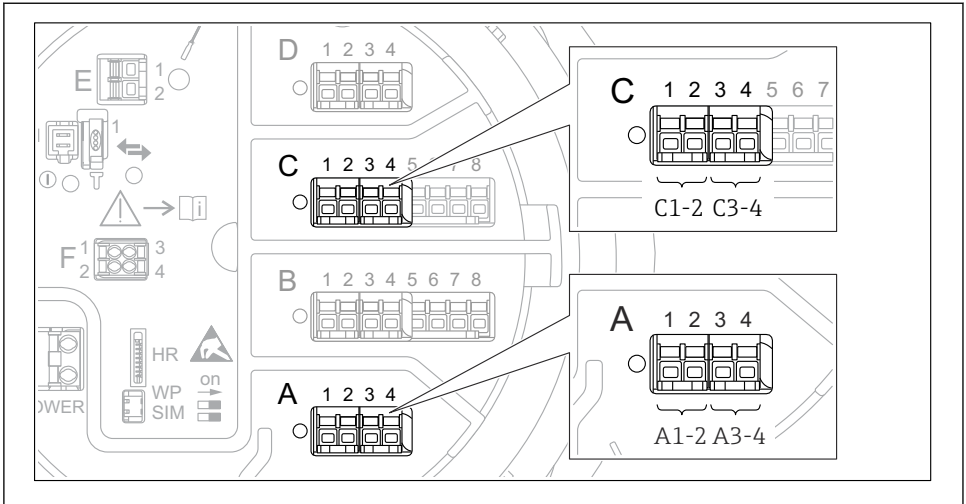

A0026424

19 Designation of the digital inputs or outputs (examples)

- Each Digital IO Module provides two digital inputs or outputs.
- In the operating menu each input or output is designated by the respective slot and two terminals within this slot. **A1-2**, for example, denotes terminals 1 and 2 of slot **A**. The same is valid for slots **B**, **C** and **D** if they contain a Digital IO module.
- For each of these pairs of terminals, one of the following operating modes can be selected in the operating menu:
 - Disable
 - Passive Output
 - Passive Input
 - Active Input

6.2 Connecting requirements

6.2.1 Cable specification

Terminals

Wire cross section 0.2 to 2.5 mm² (24 to 13 AWG)

Use for terminals with function: Signal and power supply

- Spring terminals (NMx8x-xx1...)
- Screw terminals (NMx8x-xx2...)

Wire cross section max. 2.5 mm² (13 AWG)

Use for terminals with function: Ground terminal in the terminal compartment

Wire cross section max. 4 mm² (11 AWG)

Use for terminals with function: Ground terminal at the housing

Power supply line

Standard device cable is sufficient for the power line.

HART communication line

- Standard device cable is sufficient if only the analog signal is used.
- Shielded cable is recommended if using the HART protocol. Observe the grounding concept of the plant.

Modbus communication line

- Observe the cable conditions from the TIA-485-A, Telecommunications Industry Association.
- Additional conditions: Use shielded cable.

V1 communication line

- 2-wire twisted pair, screened or unshielded cable
- Resistance in one cable: $\leq 120 \Omega$
- Capacitance between lines: $\leq 0.3 \mu\text{F}$

6.3 Ensuring the degree of protection

To guarantee the specified degree of protection, carry out the following steps after the electrical connection:

1. Check that the housing seals are clean and fitted correctly. Dry, clean or replace the seals if necessary.
2. Tighten all housing screws and screw covers.
3. Firmly tighten the cable glands.
4. To ensure that moisture does not enter the cable entry, route the cable so that it loops down before the cable entry ("water trap").

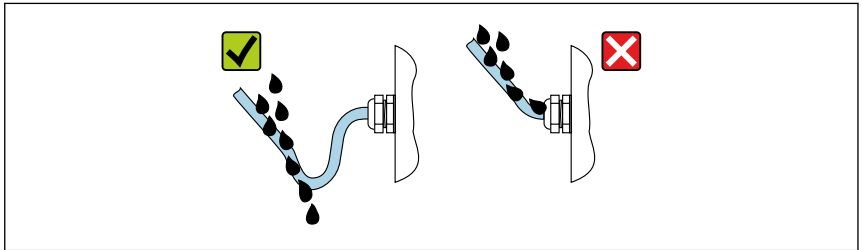

A0029278

5. Insert blind plugs appropriate for the safety rating of the device (e.g. Ex d/XP).

7 Commissioning

7.1 Operating methods

7.1.1 Operation via the local display

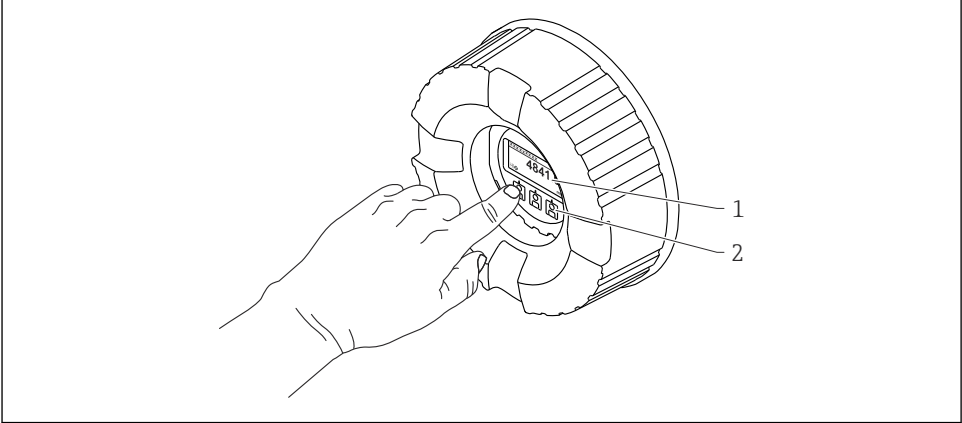

A0028345

20 Display and operating elements

- 1 Liquid crystal display (LCD)
- 2 Optical keys; can be operated through the cover glass. If used without the cover glass, lightly place your finger in front of the optical sensor for activation. Do not press hard.

Standard view (measured value display)

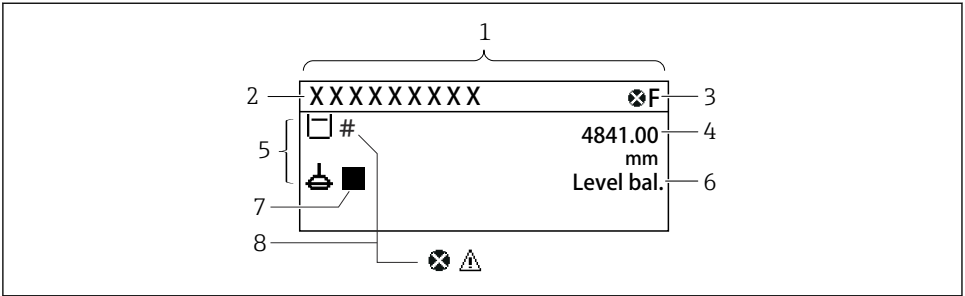

A0028702

21 Typical appearance of the standard view (measured value display)

- 1 Display module
- 2 Device tag
- 3 Status area
- 4 Display area for measured values
- 5 Display area for measured value and status symbols
- 6 Gauge status indication
- 7 Gauge status symbol
- 8 Measured value status symbol

 For the meaning of the display symbols refer to the Operating Instructions (BA) of the device.

Navigation view (operating menu)

To access the operating menu (navigation view), proceed as follows:

1. While in the standard view, press **E** for at least two seconds.
 - ↳ A context menu appears.
2. Select **Keylock off** from the context menu and confirm by pressing **E**.
3. Press **E** again to access the operating menu.

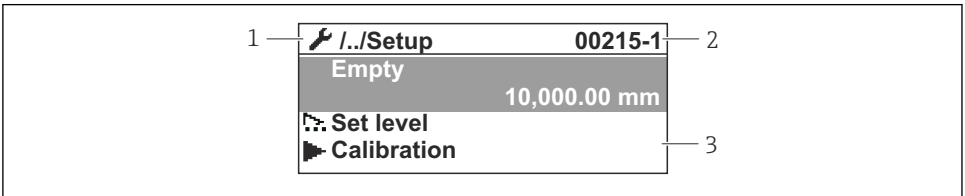

A0047115

22 Navigation view

- 1 Current submenu or wizard
- 2 Quick access code
- 3 Display area for navigation

7.1.2 Operation via service interface and FieldCare/DeviceCare

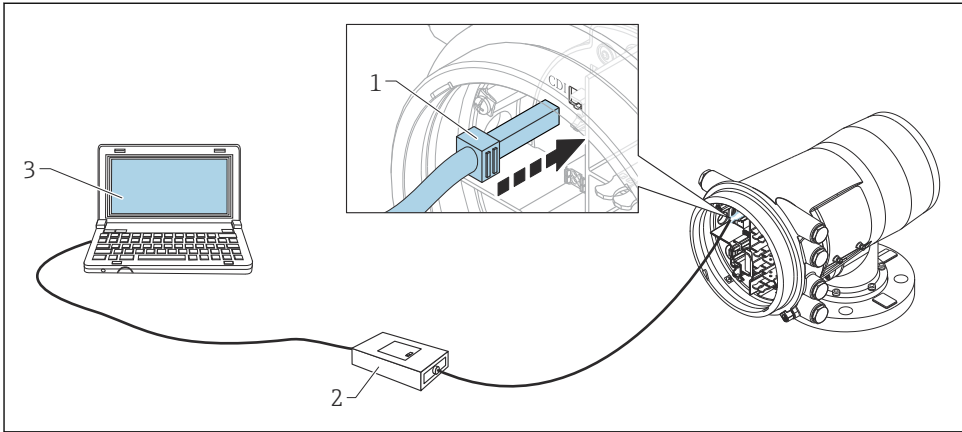

A0030161

23 Operation via service interface

- 1 Service interface (CDI = Endress+Hauser Common Data Interface)
- 2 Commbox FXA291
- 3 Computer with "FieldCare" operating tool and "CDI Communication FXA291" COM DTM

7.2 Terms related to tank measurement

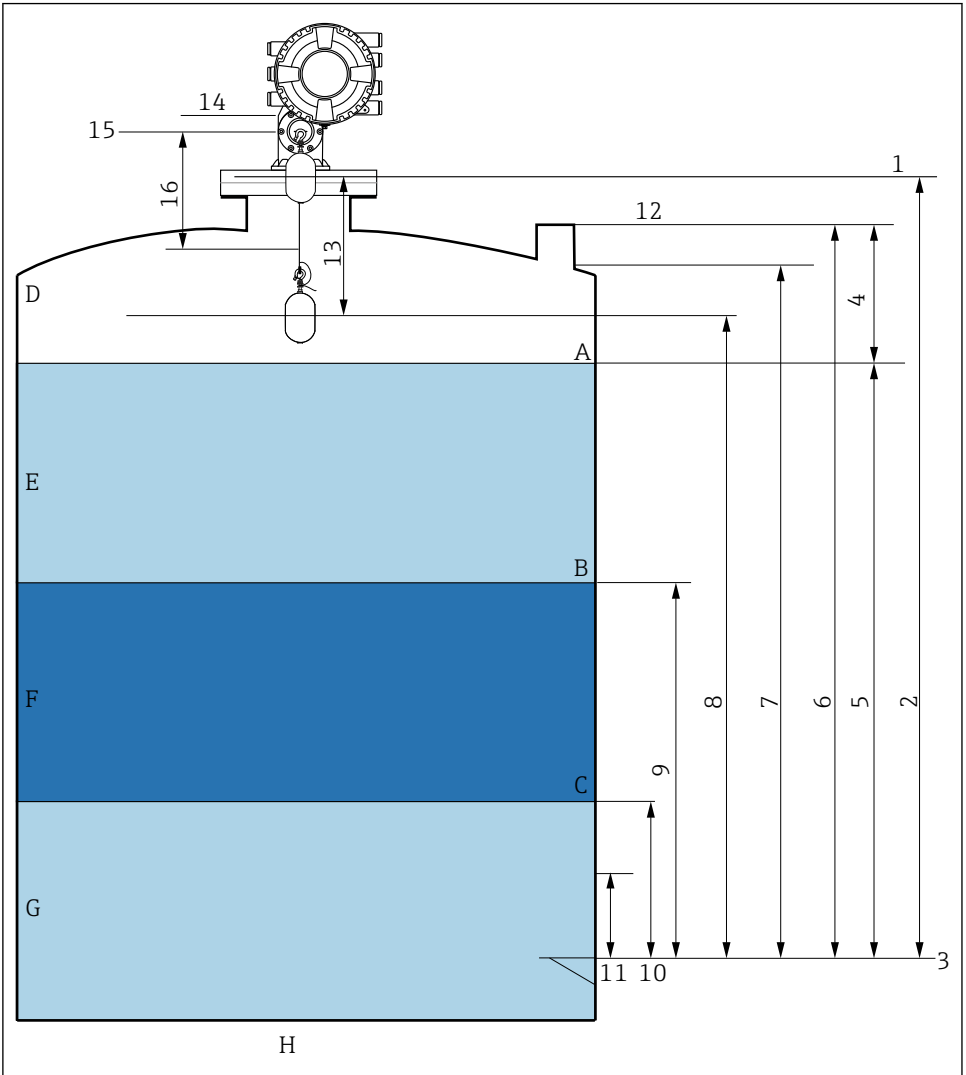

A0026916

24 Terms concerning NMS8x installation (e.g. NMS81)

- A Liquid level
- B Upper interface
- C Lower interface
- D Gas phase
- E Upper phase
- F Middle phase

G	Lower phase
H	Tank bottom
1	Gauge reference height
2	Empty
3	Datum plate
4	Tank ullage
5	Tank level
6	Tank reference height
7	High stop level (Adjustable)
8	Displacer position
9	Upper interface level
10	Lower interface level
11	Low stop level (Adjustable)
12	Dipping reference
13	Distance
14	Mechanical stop
15	Reference position
16	Slow hoist zone

7.3 Initial settings

Depending on NMS8x specification, some of the initial settings described below may not be required.

7.3.1 Setting the display language

Setting the display language via the display module

1. While in the standard view () , press "E". If required, select **Keylock off** from the context menu and press "E" again.
 - ↳ The Language appears.
2. Open the Language and select the display language.

Setting the display language via an operating tool (e.g. FieldCare)

1. Navigate to: Setup → Advanced setup → Display → Language
2. Select the display language.

 This setting only affects the language on the display module. To set the language in the operating tool use the language setting functionality of FieldCare or DeviceCare, respectively.

7.3.2 Setting the real-time clock

Setting the real-time clock via the display module

1. Navigate to: Setup → Advanced setup → Date / time → Set date
2. Use the following parameters to set the real-time clock to the current date and time:
Year, Month, Day, Hour, Minutes.

Setting the real-time clock via an operating tool (e.g. FieldCare)

1. Navigate to: Setup → Advanced setup → Date / time

2.

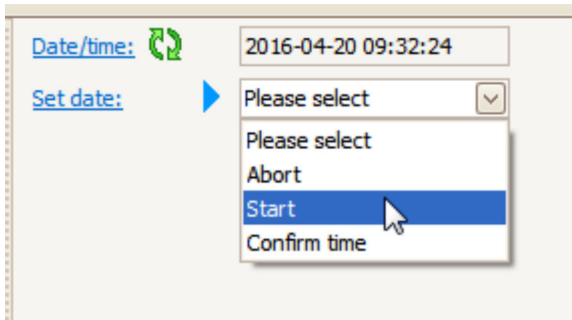

Go to the Set date and select the Start.

3.

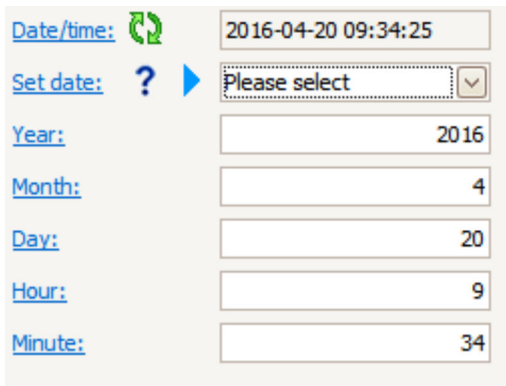
A screenshot of the same web-based configuration interface. The 'Date/time:' label is followed by a refresh icon and a text box containing '2016-04-20 09:34:25'. Below it, the 'Set date:' label is followed by a question mark icon and a blue arrow icon, and a dropdown menu with 'Please select'. Below the dropdown are five input fields: 'Year:' with '2016', 'Month:' with '4', 'Day:' with '20', 'Hour:' with '9', and 'Minute:' with '34'.

Use the following parameters to set the date and time: **Year, Month, Day, Hour, Minutes.**

4.

The screenshot shows a web interface for setting the date and time. On the left, there are labels for 'Date/time:', 'Set date:', 'Year:', 'Month:', 'Day:', 'Hour:', and 'Minute:'. The 'Date/time:' field displays '2016-04-20 09:35:49'. The 'Set date:' field is a dropdown menu that is currently open, showing a list of options: 'Please select', 'Abort', 'Start', and 'Confirm time'. The 'Confirm time' option is highlighted in blue, and a mouse cursor is pointing at it. The 'Hour:' field is set to '9' and the 'Minute:' field is set to '34'.

Go to the Set date and select the Confirm time.

↳ The real-time clock is set to the current date and time.

7.4 Calibration

After installing or replacing NMS8x or its parts (sensor module, detector unit, wire drum, or measuring wire), Perform the following calibrations in this order.

1. Sensor calibration
2. Reference calibration
3. Drum calibration

All calibration steps may not be required, depending on whether the device is being installed, adjusted, or replaced (see the table below).

Type of installation/replacement		Calibration step		
		1. Sensor calibration	2. Reference calibration	3. Drum calibration
All-in one		Not required	Not required	Not required
Displacer shipped separately		Required	Required	Required
Displacer installation through calibration window		Required	Required	Required
Replacement/ maintenance	Wire drum	Required	Required	Required
	Displacer	Not required	Required	Required
	Sensor module/ Detector unit	Required	Required	Required

7.4.1 Verification of displacer and wire drum

Prior to installation of NMS8x, confirm that all of the following data of the displacer and the wire drum on the nameplate match with those programmed into the device.

Parameters to be confirmed

Parameters	Navigate to:
Displacer diameter	Setup → Advanced setup → Sensor config → Displacer → Displacer diameter
Displacer weight	Setup → Advanced setup → Sensor config → Displacer → Displacer weight
Displacer volume	Setup → Advanced setup → Sensor config → Displacer → Displacer volume
Displacer balance volume	Setup → Advanced setup → Sensor config → Displacer → Displacer balance volume
Drum circumference	Setup → Advanced setup → Sensor config → Wire drum
Wire weight	Expert → Sensor → Sensor config → Wire drum → Wire weight

Data verification

Data verification procedure

1. Check the displacer diameter, weight, volume, and balance volume for the Displacer diameter, the Displacer weight, the Displacer volume, and the Displacer balance volume.
2. Check the drum circumference and wire weight for the Drum circumference and Wire weight.

This completes the data verification procedure.

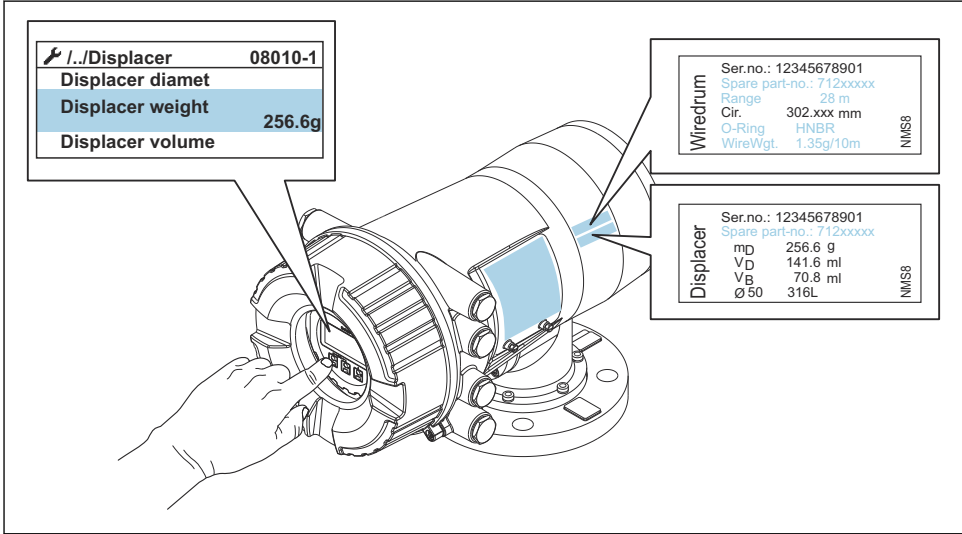

A0030107

25 Data verification

7.4.2 Move displacer

The move displacer operation is optional and can be used to change the current position of the displacer in order to perform the calibration steps more easily.

1. Make sure that the wire drum stopper has been removed.
2. Navigate to: Setup → Calibration → Move displacer → Move distance
3. Input the relative moving distance for the Move distance.
4. Select the Move down or the Move up
5. Select the **Yes**.

This completes move displacer commands procedure.

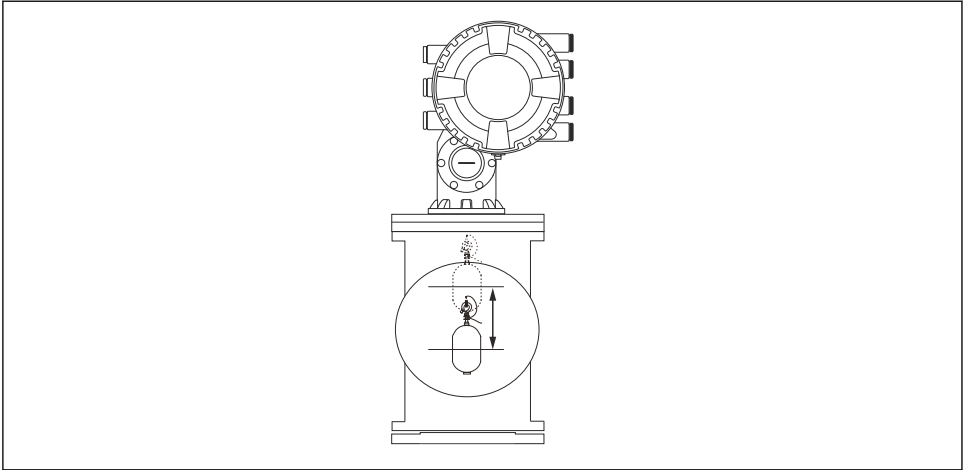

A0029119

 26 *Move displacer*

7.4.3 Sensor calibration

Sensor calibration adjusts the weight measurement of the detector unit. The calibration consists of three steps as follows.

- ADC zero calibration
- ADC offset calibration
- ADC span calibration

For the ADC offset weight calibration, either 0 g or an offset weight (0 to 100 g) can be used.



Using an offset weight other than 0 g is recommended for density measurement.

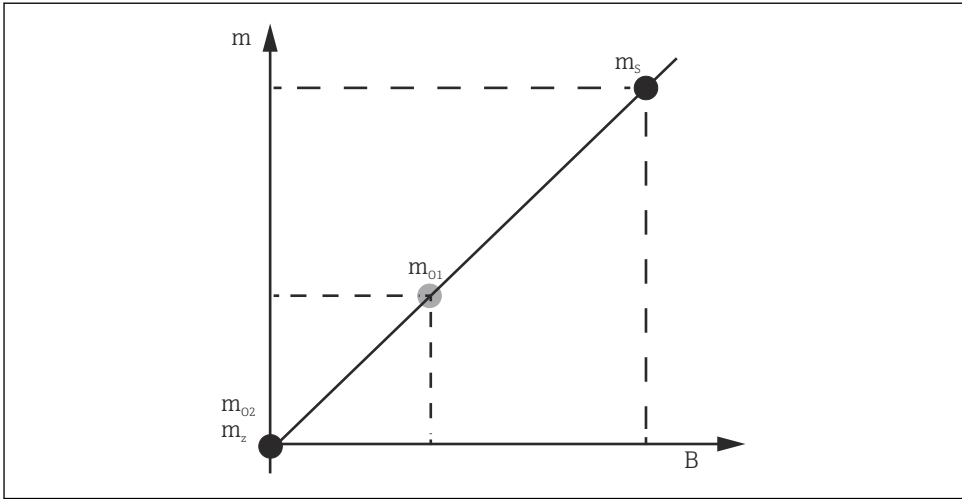

A0029472

27 Concept of sensor calibration

m Weight of displacer

B Binary value of AD-Converter











m_s Span weight

m_{o1} Offset weight in case of 0 to 100 g (50 g is recommended.)

m_{o2} Offset weight in case of 0 g

m_z Zero weight

Calibration procedure

Step	Using displacer	Using offset weight	Description
1.	 <p>A0028000</p>	 <p>A0028000</p>	<ul style="list-style-type: none"> ■ Navigate to: Setup → Calibration → Sensor calibration → Sensor calibration ■ Input the offset weight for the Offset weight used in step 3 (0.0 g in case of using the displacer only). ■ Input the value for the Span weight used in step 4 (weight of displacer indicated on nameplate).
2.	 <p>A0027999</p>	 <p>A0028001</p>	<ul style="list-style-type: none"> ■ Hold up or remove the displacer. ■ Select <input checked="" type="checkbox"/> for next parameter. ■ Measuring zero weight is shown on the display. ■ Wait until the Zero calibration shows the Finished and calibration status shows Idle. <p> When the displacer is being held up, do not release it until this step is completed.</p>
3.	 <p>A0027999</p>	 <p>A0028002</p>	<ul style="list-style-type: none"> ■ Confirm that the Offset calibration shows the Place offset weight. ■ Hold up the displacer or attach the offset weight. ■ Select <input checked="" type="checkbox"/> for next parameter. ■ Measuring offset weight is shown on the display. ■ Wait until the Offset calibration shows the Finished and Calibration status shows Idle. <p> When the displacer is being held up, do not release it until this step is completed.</p>
4.	 <p>A0028000</p>	 <p>A0028000</p>	<ul style="list-style-type: none"> ■ Release the displacer or mount it on the measuring ring if an offset weight was used in the previous step. ■ Select <input checked="" type="checkbox"/> for next parameter. ■ Measuring span weight is shown on the display. ■ Confirm that the Span calibration shows the Finished and Calibration status shows Idle. ■ Select the Next. ■ Confirm that the Sensor calibration shows the Finished and Calibration status shows Idle. <p>This completes sensor calibration procedure.</p> <p> Do not swing the displacer and keep it in as stable a position as possible.</p>

7.4.4 Reference calibration

Reference calibration procedure

The reference calibration defines the zero distance position of the displacer from the mechanical stop.

1. Navigate to: Setup → Calibration → Reference calibration → Reference calibration
2. Select the Start
3. Check the reference position (e.g. 70 mm (2.76 in)).
 - ↳ The reference position is preset prior to delivery.
4. Confirm that the displacer is correctly attached to the measuring wire.
5. The reference calibration starts automatically.

This completes the reference calibration.

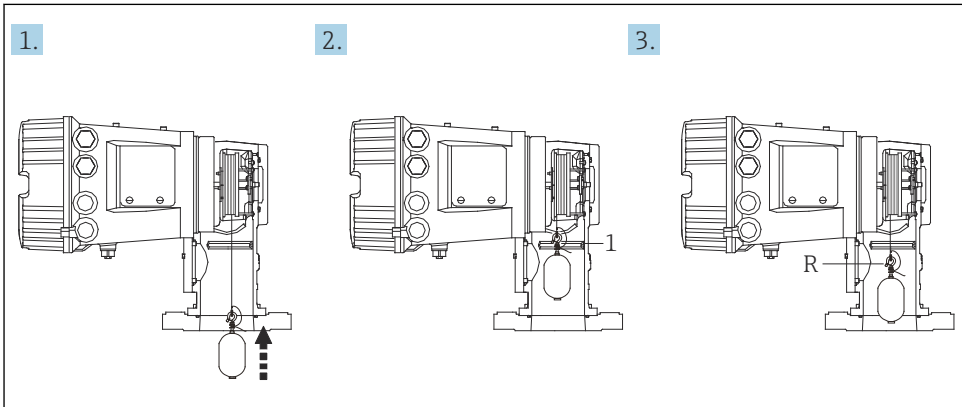

A0030162

28 Reference calibration sequence

- 1 Mechanical stop
 R Reference position

7.4.5 Drum calibration

Drum table

As shown in the following illustration, a weight measurement error (e_0 and e_1) occurs depending on the stop position of the wire drum, even if the same weight is measured. To perform the weight measurement more accurately, a drum table for correcting the error due to the stop position of the wire drum has been measured and saved into the device at the factory. Because of individual differences of the values, the wire drum is measured for all devices. It is not necessary to know about this drum table for operation.

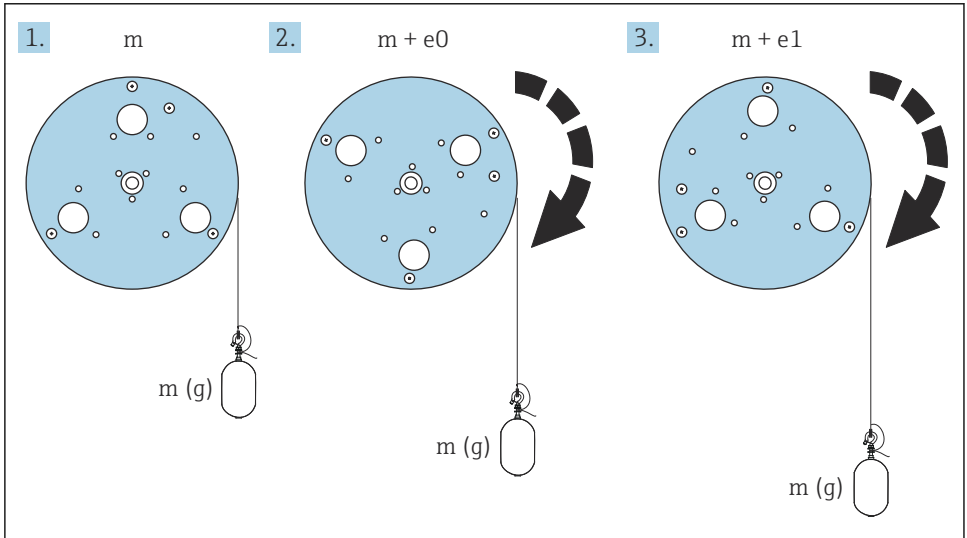

A0055640

29 Measurement weight

e Error
 m Weight

Calibration procedure

1. Navigate to: Setup → Calibration → Drum calibration → Drum calibration
2. Ensure a distance of 500 mm (19.69 in) or more from the bottom of the displacer to the liquid level.
3. Confirm that the displacer weight is correct for the Set high weight.
4. Select the Start.
 - ↳ The drum calibration starts automatically.
 The drum calibration records fifty points which will take approximately eleven minutes.

5. Select the No as usual for the Make low table.

↳ To make a low table for special applications, select the **Yes** and use 50 g weight.

This completes drum calibration procedure.

i To cancel any calibration, press $\square + \oplus$ simultaneously. If the drum calibration is canceled while making the new table, the old table remains effective. If making a new table fails due to an obstruction, NMS8x will not accept the new table and shows an error message.

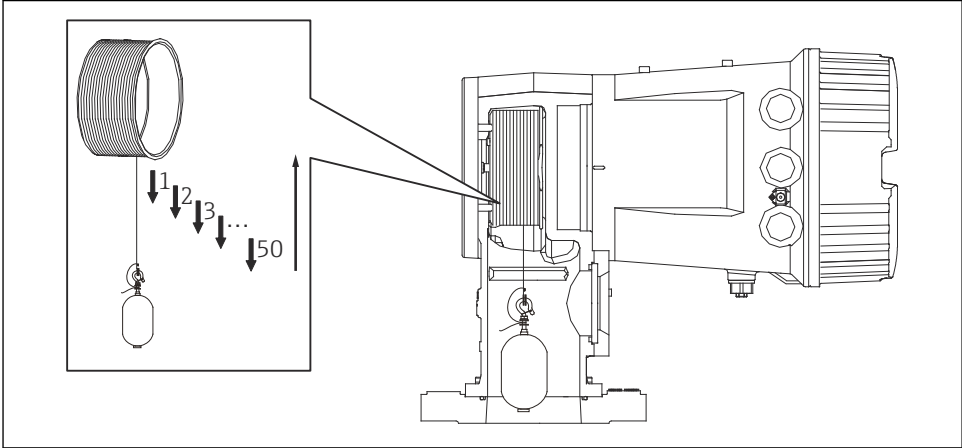

A0030163

30 Making drum table

7.4.6 Commissioning check

This procedure is to confirm that all calibration steps have been completed appropriately.

The commissioning check starts at the position where the previous drum calibration was performed. Perform drum calibration if the reference position was changed.

When skipping the drum calibration, it is necessary to ensure that there are no obstructions or interfering objects prior to the commissioning check.

The commissioning check has a total of eleven steps as follows.

The check items for the commissioning check should be performed in the following order.

- The displacer weight at the first point is within the threshold (within the specified value: 5 g (0.01 lb)).
- Ten points out of fifty, when the previous drum table was created, are selected and compared with the result of the current weight table and detected weight will be confirmed.
- Confirm the displacer weight is within the threshold (within specified value: 5 g (0.01 lb)) at each point.

If the displacer weight exceeds the threshold in the ten steps, the commissioning check stops and the gauge status changes to Stop.

To continue the level measurement, perform the gauge command.

The following three items are confirmed in the last step.

- The difference of the neighboring two points is within the threshold (within the specified value: 2 g (0.004 lb)).
- Peak-to-peak of the compensation value in the drum table is within 20 g (0.04 lb).
- The maximum compensation value in the drum table is within 40 g (0.09 lb).

Overtension is not confirmed during execution of the commissioning check.

Prior to drum calibration, ensure that there is nothing interfering with where the previous drum calibration was performed.

1. Navigate to: Diagnostics → Device check → Commissioning check → Commissioning check
2. Select the Start.
 - ↳ Executing is shown on the verify drum table.
3. Select the Start.
4. Confirm that the Commissioning check shows the Finished.
5. Confirm that the Result drum check is passed.

This completes the commissioning check procedure.

7.5 Configuration of the inputs

7.5.1 Configuration of the HART inputs

Connecting and addressing HART devices

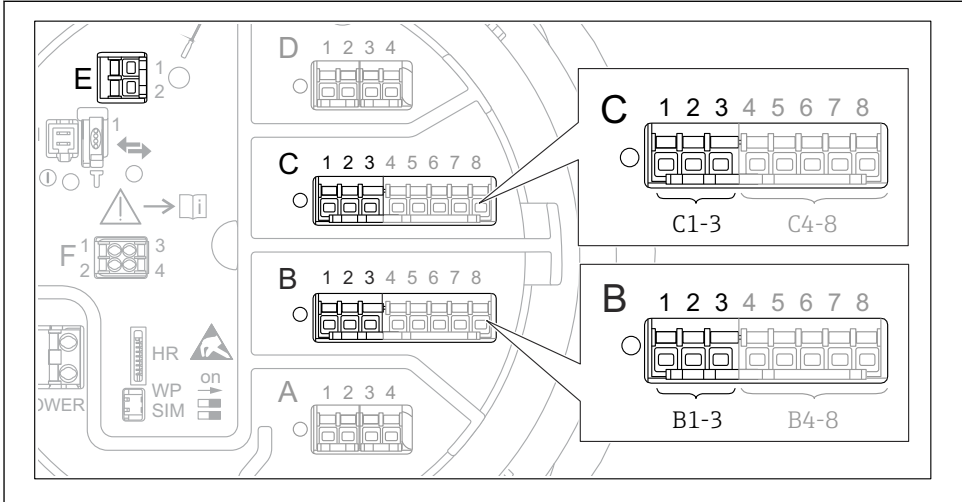

A0032955

31 Possible terminals for HART loops

- B* Analog I/O module in slot B (availability depending on device version)
- C* Analog I/O module in slot C (availability depending on device version)
- E* HART Ex is output (available in all device versions)

i HART devices must be configured and given a unique HART address via their own user interface before they are connected to the Proservo NMS8x³⁾.

Submenu: Setup → Advanced setup → Input/output → Analog I/O

Parameter	Meaning / Action
Operating mode	Select: <ul style="list-style-type: none"> ▪ HART master+4..20mA input if only one HART device is connected to this loop. In this case the 4-20mA signal can be used in addition to the HART signal. ▪ HART master if up to 6 HART devices are connected to this loop.

3) The current software does not support HART devices with address 0 (zero).

Submenu: Setup → Advanced setup → Input/output → HART devices → HART Device(s) ^{1) 2)}	
Parameter	Meaning / Action
Output pressure	<ul style="list-style-type: none"> ■ If the device measures a pressure: Select which of the HART variables (PV, SV, TV or QV) contains the pressure. ■ Otherwise: Keep the factory setting: No value
Output density	<ul style="list-style-type: none"> ■ If the device measures a density: Select which of the HART variables (PV, SV, TV or QV) contains the density. ■ Otherwise: Keep the factory setting: No value
Output temperature	<ul style="list-style-type: none"> ■ If the device measures a temperature: Select which of the HART variables (PV, SV, TV or QV) contains the temperature. ■ Otherwise: Keep the factory setting: No value
Output vapor temperature	<ul style="list-style-type: none"> ■ If the device measures the vapor temperature: Select which of the HART variables (PV, SV, TV or QV) contains the vapor temperature. ■ Otherwise: Keep the factory setting: No value
Output level	<ul style="list-style-type: none"> ■ If the device measures a level: Select which of the HART variables (PV, SV, TV or QV) contains the level. ■ Otherwise: Keep the factory setting: No value

- 1) There is a "HART Device(s)" for each connected HART device.
- 2) This setting can be skipped for a connected Prothermo NMT5xx and NMT8x or Micropilot FMR5xx as for these devices the type of measured value is identified automatically.

7.5.2 Configuration of the 4-20mA inputs

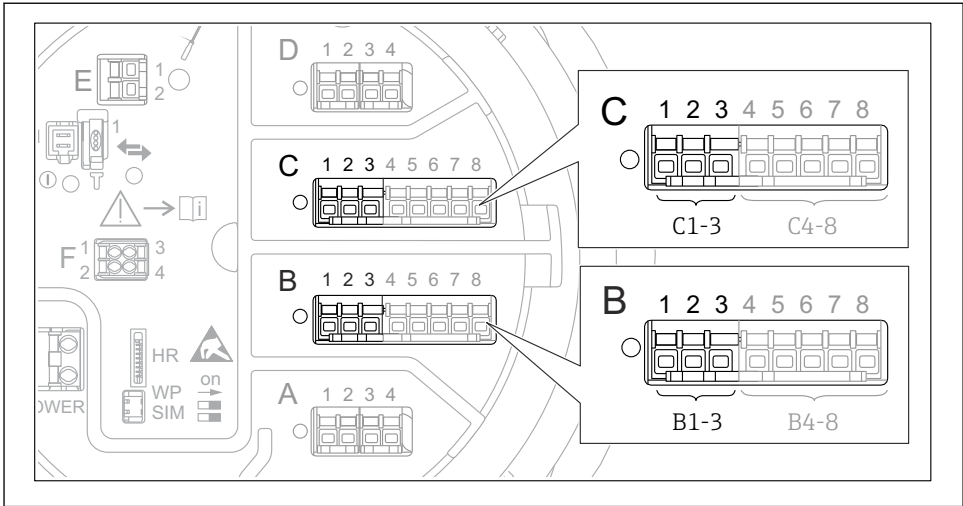

A0032464

32 Possible locations of the Analog I/O modules, which can be used as a 4-20mA input. The order code of the device determines which of these modules is actually present.

Submenu: Setup → Advanced setup → Input/output → Analog I/O ¹⁾	
Parameter	Meaning / Action
Operating mode	Select 4..20mA input or HART master+4..20mA input
Process variable	Select which process variable is transmitted by the connected device.
Analog input 0% value	Define which value of the process variable corresponds to an input current of 4 mA.
Analog input 100% value	Define which value of the process variable corresponds to an input current of 20 mA.
Process value	Check whether the indicated value matches the actual value of the process variable.

1) There is a "Analog I/O" for each Analog I/O module of the device.

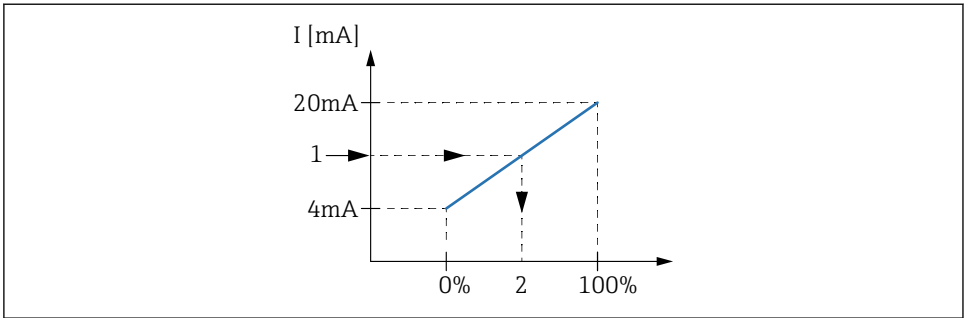

A0029264

33 Scaling of the 4-20mA input to the process variable

- 1 Input value in mA
- 2 Process value

7.5.3 Configuration of a connected RTD

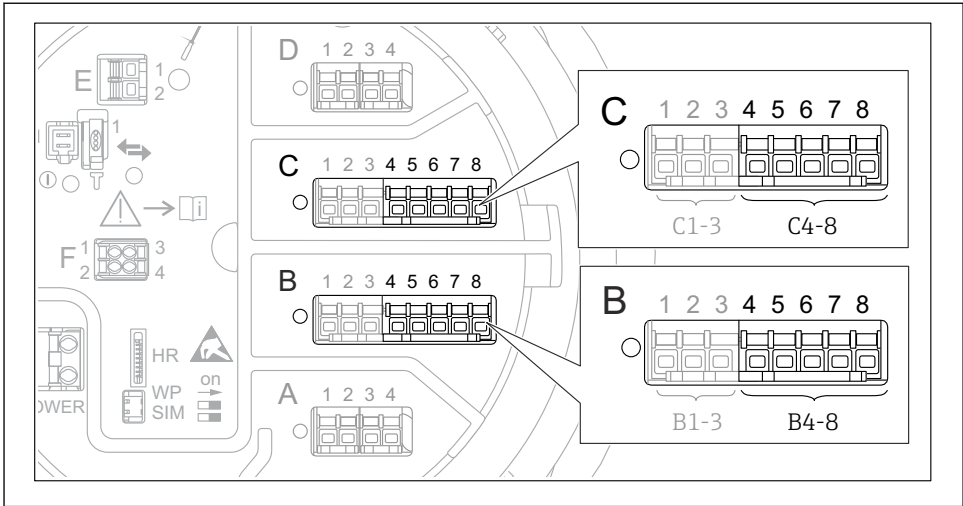

A0032465

34 Possible locations of the Analog I/O modules, to which an RTD can be connected. The order code of the device determines which of these modules is actually present.

Submenu: Setup → Advanced setup → Input/output → Analog IP	
Parameter	Meaning / Action
RTD type	Specify the type of the connected RTD.
RTD connection type	Specify the type of connection of the RTD (2-, 3- or 4-wire).
Input value	Check whether the indicated value matches the actual temperature.
Minimum probe temperature	Specify the minimum approved temperature of the connected RTD.
Maximum probe temperature	Specify the maximum approved temperature of the connected RTD.
Probe position	Enter the mounting position of the RTD (measured from the datum plate).

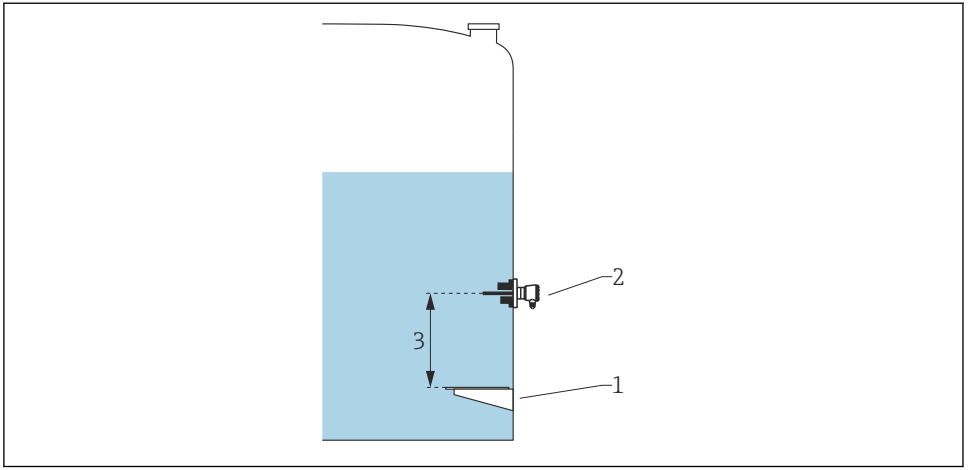

A0029269

- 1 Datum plate
- 2 RTD
- 3 Probe position

7.5.4 Configuration of the digital inputs

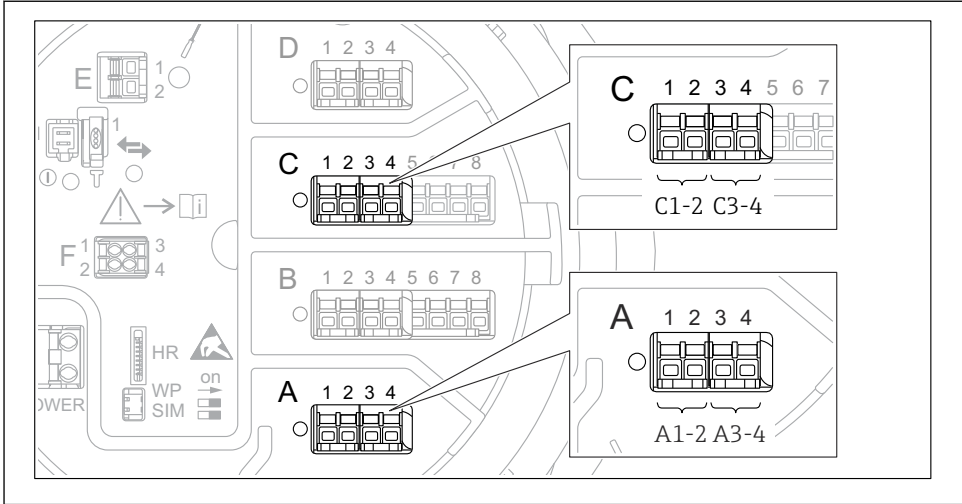

A0026424

- 35 Possible locations of the Digital I/O modules (examples); the order code defines the number and location of digital input modules.

There is a **Digital Xx-x** for each digital I/O module of the device. "X" designates the slot in the terminal compartment, "x-x" the terminals within this slot. The most important parameters of this submenu are **Operating mode** and **Contact type**.

Submenu: Setup → Advanced setup → Input/output → Digital Xx-x

Parameter	Meaning / Action
Operating mode	Select the operating mode (see diagram below). <ul style="list-style-type: none"> ▪ Input passive The DIO module measures the voltage provided by an external source. Depending on the status of the external switch, this voltage is 0 (switch open) or exceeds a certain limit voltage (switch closed). These two states represent the digital signal. ▪ Input active The DIO module provides a voltage and uses it to detect whether the external switch is open or closed.
Contact type	Determines how the state of the external switch is mapped to the internal states of the DIO module (see table below). The internal state of the Digital Input can then be transferred to a Digital Output or can be used to control the measurement.

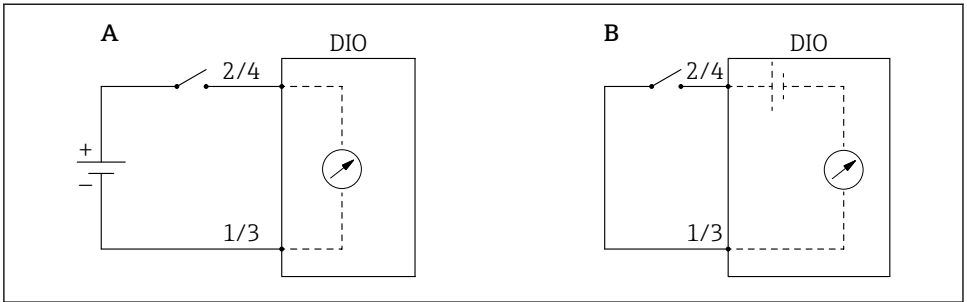

A0029262

A "Operating mode" = "Input passive"

B "Operating mode" = "Input active"

State of the external switch	Internal state of the DIO module	
	Contact type = Normally open	Contact type = Normally closed
Open	Inactive	Active
Closed	Active	Inactive
Behavior in special situations:		
During start-up	Unknown	Unknown
Fault in measurement	Error	Error

7.6 Linking measured values to tank variables

Measured values must be linked to tank variables before they can be used in the Tank Gauging application.



Depending on the application not all these parameters will be relevant in a given situation.

Submenu: Setup → Advanced setup → Application → Tank configuration → Level	
Parameter	Defines the source of the following tank variable
Level source	Product level
Water level source	Bottom water level

Submenu: Setup → Advanced setup → Application → Tank configuration → Temperature	
Parameter	Defines the source of the following tank variable
Liquid temp source	Average or spot temperature of the product
Air temperature source	Temperature of the air surrounding the tank
Vapor temp source	Temperature of the vapor above the product

Submenu: Setup → Advanced setup → Application → Tank configuration → Pressure	
Parameter	Defines the source of the following tank variable
P1 (bottom) source	Bottom pressure (P1)
P3 (top) source	Top pressure (P3)

7.7 Configuration of the alarms (limit evaluation)

A limit evaluation can be configured for up to 4 tank variables. The limit evaluation issues an alarm if the value exceeds an upper limit or falls below a lower limit, respectively. The limit values can be defined by the user.

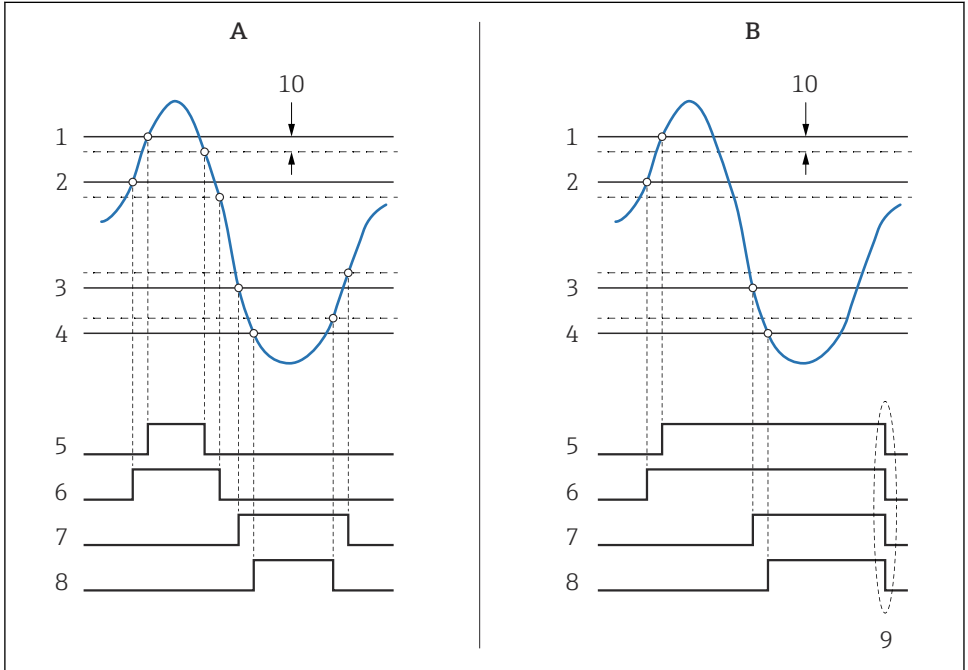

A0029539

36 Principle of the limit evaluation

- A Alarm mode = On
- B Alarm mode = Latching
- 1 HH alarm value
- 2 H alarm value
- 3 L alarm value
- 4 LL alarm value
- 5 HH alarm
- 6 H alarm
- 7 L alarm
- 8 LL alarm
- 9 "Clear alarm" = "Yes" or power off-on
- 10 Hysteresis

To configure an alarm, assign appropriate values to the following parameters:

Submenu: Setup → Advanced setup → Application → Alarm → Alarm 1 to 4	
Parameter	Meaning / Action
Alarm mode	<ul style="list-style-type: none"> ▪ Off No alarms are generated. ▪ On An alarm disappears if the alarm condition is no longer present (taking into consideration the hysteresis). ▪ Latching All alarms remain active until the user selects Clear alarm = Yes.
Alarm value source	Select process variable to be checked for limit violation.
<ul style="list-style-type: none"> ▪ HH alarm value ▪ H alarm value ▪ L alarm value ▪ LL alarm value 	Assign appropriate limit values (see diagram above).

7.8 Configuration of the signal output

7.8.1 Analog output 4 to 20 mA output

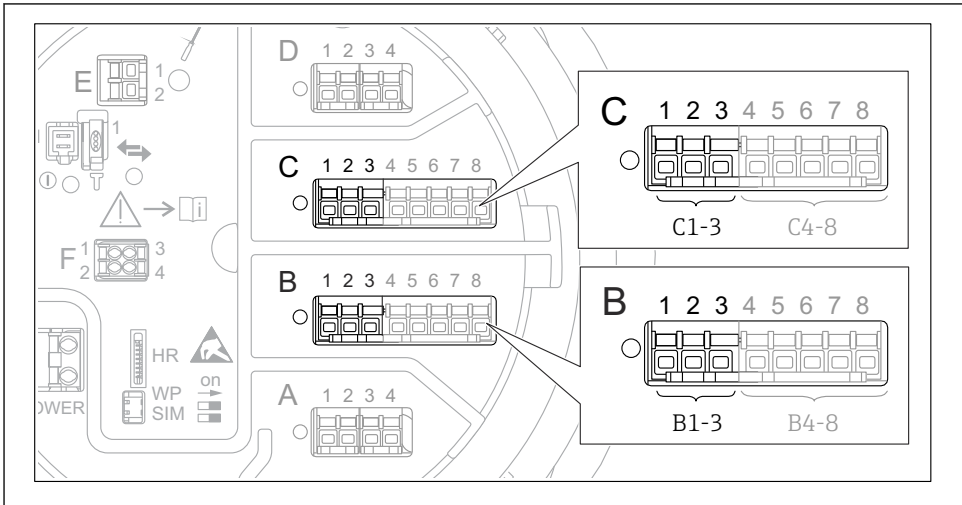

A0032464

- 37 Possible locations of the Analog I/O modules, which can be used as a 4 to 20 mA output. The order code of the device determines which of these modules is actually present.

Each Analog I/O module of the device can be configured as 4 to 20 mA analog output. To do so, assign appropriate values to the following parameters:

Setup → Advanced setup → Input/output → Analog I/O	
Parameter	Meaning / Action
Operating mode	Select 4..20mA output or HART slave +4..20mA output ¹⁾ →  74.
Analog input source	Select which tank variable is transmitted via the analog output.
Analog input 0% value	Specify which value of the tank variable corresponds to an output current of 4 mA.
Analog input 100% value	Specify which value of the tank variable corresponds to an output current of 20 mA.

- 1) "HART slave +4..20mA output" means that the Analog I/O module serves as a HART slave which cyclically sends up to four HART variables to a HART master. For the configuration of the HART output:

7.8.2 HART output

This section is only valid for **Operating mode = HART slave +4..20mA output**.

Setup → Advanced setup → Communication → HART output → Configuration	
Parameter	Meaning / Action
System polling address	Set the HART communication address of the device.
<ul style="list-style-type: none"> ▪ Assign SV ▪ Assign TV ▪ Assign QV 	<p>Select which tank variables are to be transmitted by the HART variables.</p> <p> By default, PV transmits the same variable as the analog output and needs not to be assigned.</p>

7.8.3 Modbus, V1 or WM550 output

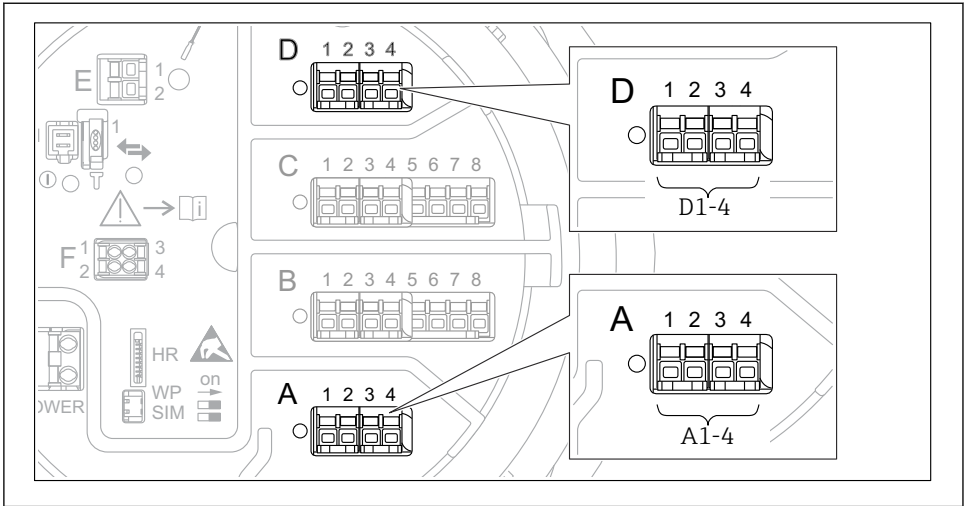

38 Possible locations of the Modbus or V1 modules (examples); depending on the device version these modules may also be in slot B or C .

Depending on the order code the device may have one or two Modbus or V1 communication interfaces. These are configured in the following submenus:

Modbus

Setup → Advanced setup → Communication → Modbus X1-4 → Configuration

V1

- Setup → Advanced setup → Communication → V1 X1-4 → Configuration
- Setup → Advanced setup → Communication → V1 X1-4 → V1 input selector

WM550

- Setup → Advanced setup → Communication → WM550 X1-4 → Configuration
- Setup → Advanced setup → Communication → WM550 X1-4 → WM550 input selector



71682623

www.addresses.endress.com
