

GMS800 FIDOR®

Total hydrocarbon analyzer

Solution for continuous hydrocarbon measurements

- High availability (99.5 %)
- Convenient via ethernet, remote diagnosis and operation
- Minimum maintenance costs due to the absence of moving parts
- Replacement of complete assemblies and modules makes repairs easy
- Compatible with predecessor systems
- Hydrogen as fuel gas, expensive helium is not required
- Low operating costs

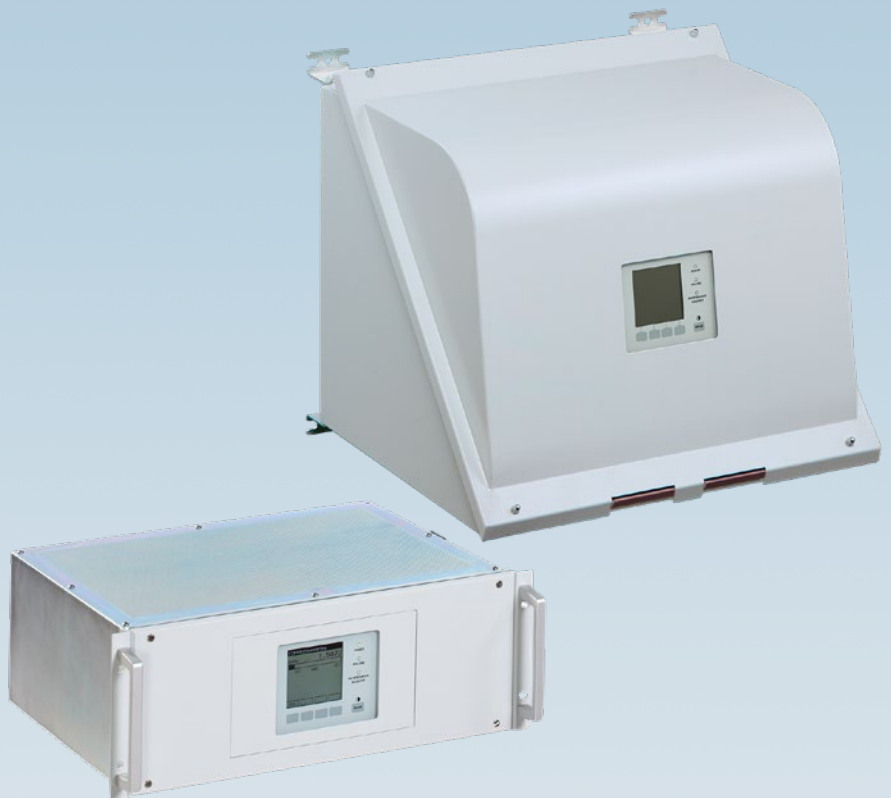

Solution for continuous hydrocarbon measurements

The compact GMS800 FIDOR® extractive gas analyzer is the solution for continuous hydrocarbon measurements. Both the standalone and the integrated system versions combine rugged design, ease of operation, precision measuring, and modern interfaces to achieve very high availability of 99.5 %. This means more reliability and better measurement certainty when monitoring emissions of total

hydrocarbon concentrations. Where operating costs are concerned, the GMS800 FIDOR® features low consumption of hydrogen as its fuel gas, compact dimensions, and maintenance-free ejector pump. The modular and simple construction inside the device allow for easy maintenance and servicing.



High measurement certainty

The GMS800 FIDOR continuously measures hydrocarbon concentrations – without any moving parts featuring in the design of the analyzer. Wear and mechanical failures are not an issue. Another plus is that the ejector pump for the sample gas is maintenance-free. Stable measurement certainty is assured in the long term. The very high availability (99.5 %) of the hydrocarbon analyzer is a major factor in this regard. The GMS800 FIDOR can be relied upon to deliver valid measured values at all times.

Minimum maintenance required

The GMS800 FIDOR has a certified maintenance interval of three months. Achieved due to the durability of the device, resulting in low cost of ownership.

High operational safety

The GMS800 FIDOR is also capable of operation in an extended process gas pressure range of ± 120 mbar. Protective filters at all gas inlets provide increased protection against contamination and failure. As a result, the GMS800 FIDOR is able to achieve high levels of operational safety.

Cost-effective measuring

The GMS800 FIDOR uses hydrogen for fuel gas and, at 30 ml/min (typical), consumption is low. An expensive hydrogen/helium mixture is not required. All this combined makes for efficient measuring.

Combining user-friendliness with convenient remote operation

As standard, the basic control unit (BCU) for the GMS800 FIDOR is available directly on the device. Retrieving measured values or remote diagnosis can be carried out quickly and conveniently via optional remote control.

Fully tested for suitability inline with EN 15267-3

Having passed EN 15267-3 suitability testing and boasting outstanding performance figures, the GMS800 FIDOR guarantees availability of 99.5 %. The certification is valid for the entire system including analyzer, probe, heated sample gas inlet, and catalytic converter.

Versions: GMS800 FIDOR



GMS810 FIDOR: 19" design with integrated basic control unit (BCU)

In the compact 19" design, the GMS810 FIDOR with integrated basic control unit (BCU) features a user interface menu with password protected access to all relevant settings and diagnosis functions.



GMS811 FIDOR: 19" design with external basic control unit (BCU)

The GMS811 FIDOR comprises the 19" housing and the separate basic control unit (BCU). The BCU can be set up separately as a complete external unit including I/O signals and interfaces for convenient control and monitoring of the analyzer locally (in a maintenance control room, for example).



GMS840 FIDOR: wall housing (stand-alone) with integrated basic control unit (BCU)

The space-saving wall housing model GMS840 FIDOR for stand-alone operation. Enclosure rating class IP54 with purge gas and pneumatic hydrogen shutoff.

GMS800 FIDOR®:

Solution for continuous hydrocarbon measurements



Product description

A member of the innovative GMS800 analyzer family, the GMS800 FIDOR extractive gas analyzer is ideally suited for emission monitoring according to regulatory requirements (in waste incinerators, cement and/or power plants, for example). Based on the proven flame ionization detection principle, the GMS800 FIDOR measures total hydrocarbon concentrations in gases at both trace levels

At a glance

- Standard 19" housing for easy integration into typical industrial systems
- Space-saving wall housing (stand-alone)
- Virtually maintenance-free ejector pump for conveying sample gas
- Internal catalytic converter (option) for cleaning zero gas and combustion air

Your benefits

- High availability (99.5 %)
- Convenient remote diagnosis and operation via ethernet using SOPAS-ET software
- Minimum maintenance costs due to the absence of moving parts
- Replacement of complete assemblies and modules makes repairs easy
- Compatible with predecessor systems

and high concentration levels.

The GMS800 FIDOR is available in three versions: the GMS810 FIDOR with integrated control unit (BCU), the GMS811 FIDOR with separate control unit (BCU) and the GMS840 FIDOR with a space-saving wall housing. The housing makes stand-alone operation and the integration into existing systems such as the MCS200 HW multi-component analyzer very easy.

- Protective filter at sample gas inlet
- Automatic regulation and compensation of in-process pressure fluctuations
- High degree of linearity ($\leq 2\%$) for very low through high measuring ranges
- Suitability tested according to EN 15267 and EN 14181

- Hydrogen as fuel gas, expensive helium is not required
- Low operating costs, e.g., due to low hydrogen consumption (typical 30 ml/min)
- The GMS811 FIDOR, on which the control unit (BCU) can be separated from the analyzer unit, supports convenient control and monitoring from a central control room.



More Information online

For more information, enter the link or scan the QR code to get direct access to technical data, operating instructions, software, application examples, and much more.

www.endress.com/gms800fidor



Fields of application

- Continuous monitoring of hydrocarbon emissions in raw gas and clean gas
- Emissions measurement in thermal, catalytic, and biological exhaust gas cleaning systems
- Measurement of maximum workplace concentrations
- Process monitoring in process systems
- Laboratory applications, e.g., in research and development

Detailed technical data

GMS800 FIDOR

Sample quantity	≤ 120 l/h
Process temperature	≤ +230 °C
Process pressure	-120 hPa ... 120 hPa relative
Process gas humidity	Non-condensing
Ambient temperature	+5 °C ... +40 °C
Storage temperature	-20 °C ... +70 °C
Ambient pressure	900 hPa ... 1.100 hPa
Ambient humidity	≤ 95 % non-condensing
Electrical safety	CE
Electrical connection	
Voltage	90 ... 240 V
Frequency	47 ... 63 Hz
Power consumption	≤ 450 W
Auxiliaries	
Instrument air:	≤ 1.000 l/h Instrument air: 4±0.2 bar; particle size max. 1 µm; oil content max. 0.1 mg/m ³ ; pressure condensation point max. -40 °C
Fuel gas:	Typical 30 ml/min Hydrogen: 5.0 or higher; 3±0.2 bar
Combustion air:	Typ. 250 ml/min Instrument air: 3±0.2 bar; measuring ranges below 300 ppm (500 mg/m ³) require an internal or external catalytic converter
Zero gas:	≤ 500 l/h Instrument air: 3±0.2 bar; measuring ranges below 300 ppm (500 mg/m ³) require an internal or external catalytic converter
Reference gas:	≤ 500 l/h Propane in synthetic air: 75 % of measuring range final value; 3±0.2 bar
Purge gas:	> 1.200 l/h Air for purging enclosure
Corrective functions	Adjustment with test gases
Test functions	Extended device diagnosis with SOPAS ET software
Scope of delivery	The scope of delivery depends on application and customer specifications

Design GMS810

Description	19" rack housing with 4 rack units, for integration in cabinets
Enclosure rating	IP40
Dimensions (W x H x D)	483 mm x 177 mm x 485 mm (for details see dimensional drawing)
Weight	17 kg
Power supply	
Voltage	90 ... 240 V
Frequency	47 ... 63 Hz
Power consumption	≤ 450 W
Sample connections	Sample gas inlet: G 1/4"; G 1/8" double, no protection against kinking; G 1/8" no protection against kinking Exhaust gas outlet: 12 mm straight; 1/2" straight; 10 mm 90° bent
Auxiliary connections	Auxiliary gas inlet: Varies depending on type

Design GMS811

Description	19" rack housing with 4 rack units, for use with separate control unit (BCU), for integration in cabinets
Enclosure rating	IP40
Dimensions (W x H x D)	483 mm x 177 mm x 352 mm (for details see dimensional drawing)
Weight	17 kg
Power supply	
Voltage	90 ... 240 V
Frequency	47 ... 63 Hz
Power consumption	≤ 450 W
Sample connections	Sample gas inlet: G 1/4"; G 1/8" double, no protection against kinking; G 1/8" no protection against kinking Exhaust gas outlet: G 1/4"; G 1/8" double, no protection against kinking; G 1/8" no protection against kinking
Auxiliary connections	Auxiliary gas inlet: Varies depending on type

Design GMS840

Description	Closed steel sheet housing for wall mounting for use indoors
Enclosure rating	IP 54
Dimensions (W x H x D)	522 mm x 475 mm x 478 mm (for details see dimensional drawing)
Weight	20 kg
Power supply	
Voltage	90 ... 240 V
Frequency	47 ... 63 Hz
Power consumption	≤ 450 W
Sample connections	Sample gas inlet: screw-in fittings, 6 mm, G1/8", stainless steel Exhaust gas outlet: G 1/4"
Auxiliary connections	Varies depending on type

Analyzer unit FIDOR

Description	Flame ionization detector for measuring volatile organic components (VOC)
Measuring components	Total carbon (C_{org})
TÜV-approved measured values	Total carbon (C_{org})
Measurement principle	Flame ionization detection
Sample quantity	≤ 120 l/h
Measuring ranges	
	C_{org} 0 ... 0.6 ppm / 0 ... 62,000 ppm
	A flame arrester must be provided by the customer when measuring gas concentrations above the lower explosion limit (LEL).
Certified measuring ranges	
	C_{org} 0 ... 15 mg/m ³ / 0 ... 50 mg/m ³ / 0 ... 150 mg/m ³ / 0 ... 500 mg/m ³
Response time	$\leq 2,5$ s No sample gas line
Sensitivity drift	< 3 % within the maintenance interval, relative to measuring range final value
Zero point drift	< 3 % within the maintenance interval, relative to measuring range final value
Detection limit	C_{org} : 0,05 mg/m ³
Electrical safety	CE

Basic control unit BCU

Description	The control unit serves as the user interface and is responsible for data processing and output as well as control and monitoring functions.
Display	Status LEDs: "Power", "Maintenance", and "Fault" LC display
Operation	Via LC display and membrane keyboard
Dimensions (W x H x D)	375 mm x 275 mm x 66 mm (with separate control unit (BCU); for details see dimensional drawings)

I/O module

Description	Closed module with top-hat rail adapter or open module for integration into housing
Analog outputs	4 outputs: 0/2/4 ... 20 mA, 500 Ω , galvanically isolated
Analog inputs	2 inputs: 0/2/4 ... 20 mA, 500 Ω , not galvanically isolated
Digital inputs	8 inputs: + 42 V All inputs with common reference potential
Modbus	✓
Type of fieldbus integration	TCP RTU RS-485
Ethernet TCP/IP	✓
Function	Connection to SOPAS ET software or OPC server

Ordering information

Our regional sales organization will help you to select the optimum device configuration.

Dimensional drawings

GMS810 FIDOR (dimensions in mm (inch))

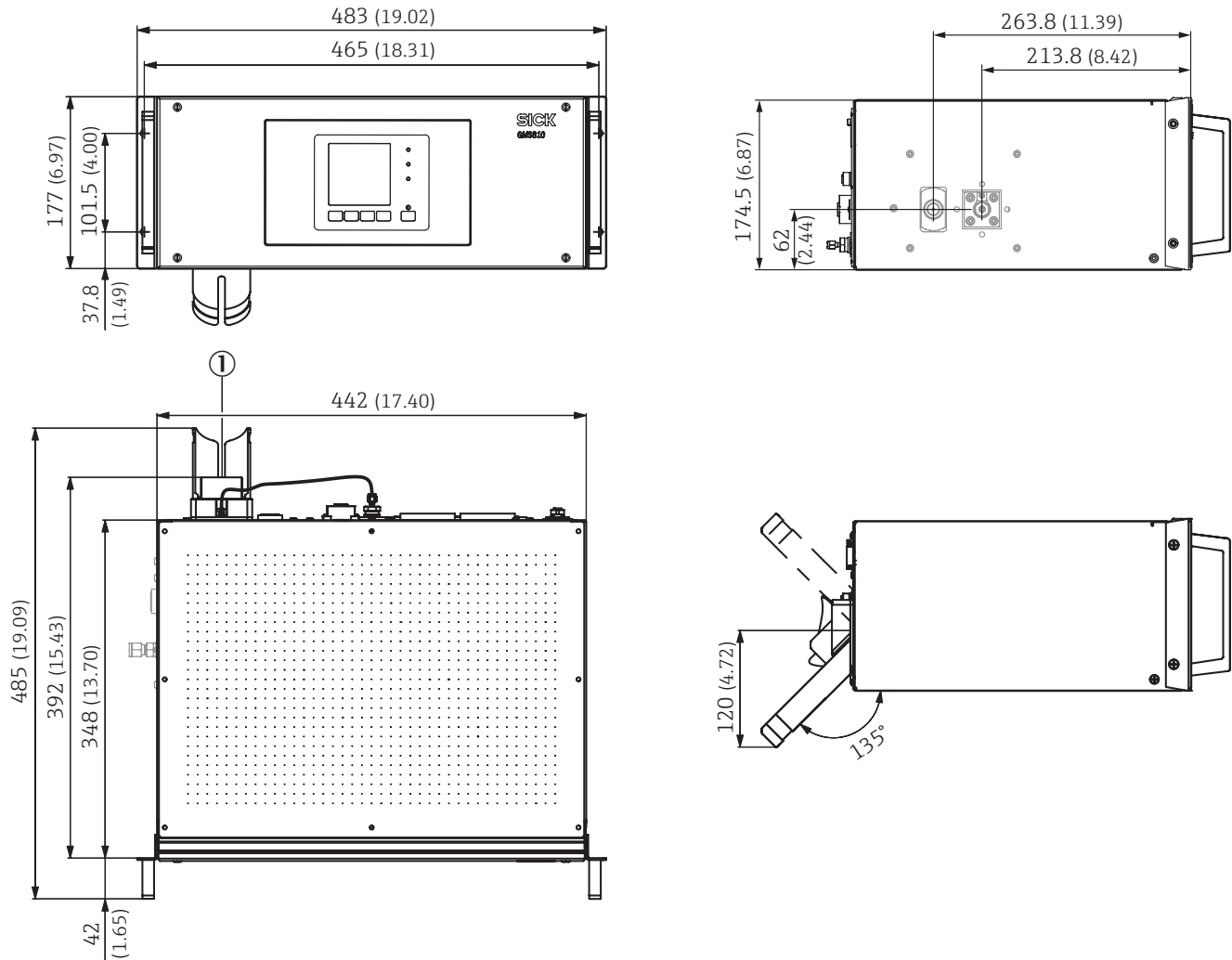

① On the GMS810 FIDOR, the sample gas inlet can be located on the rear or on the side (shown in light grey).

GMS811 FIDOR (dimensions in mm (inch))

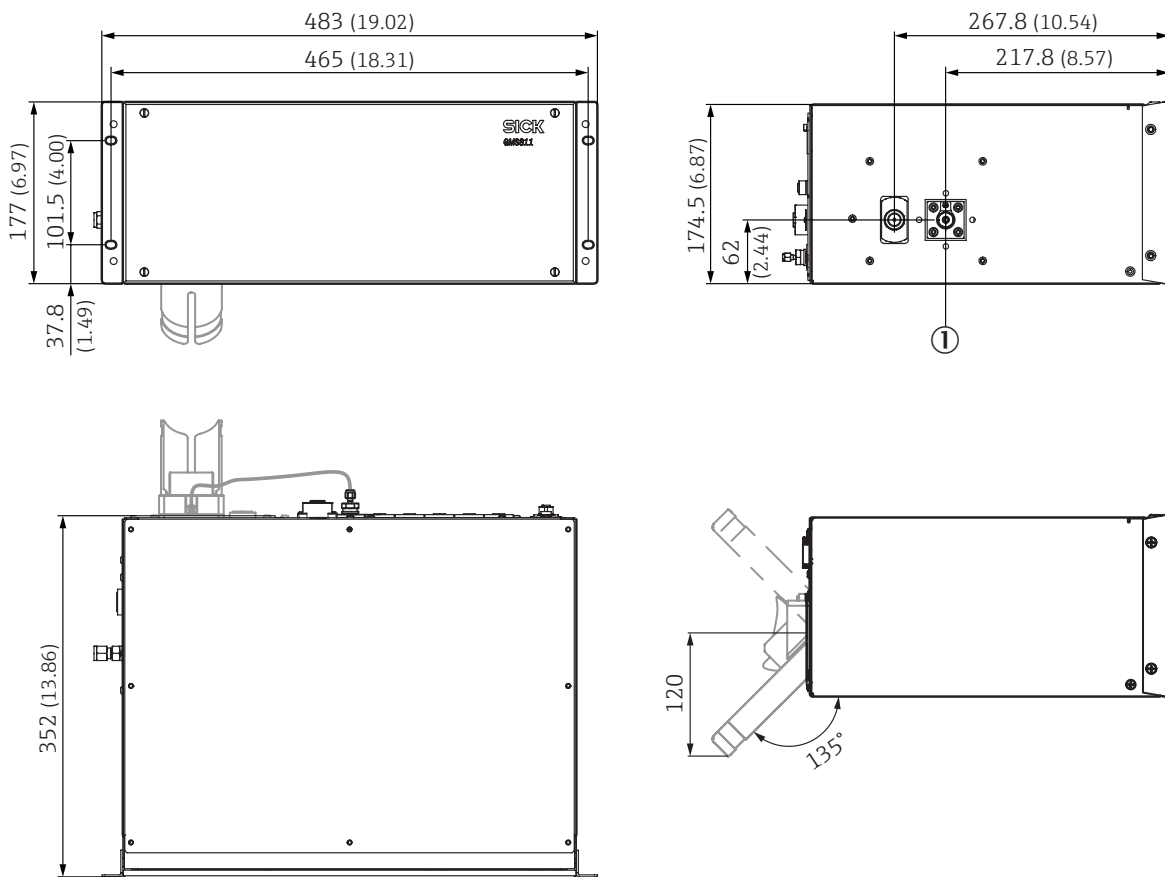

① On the GMS811 FIDOR, the sample gas inlet can be located on the side or on the rear (shown in light grey).

Control unit BCU(dimensions in mm (inch))

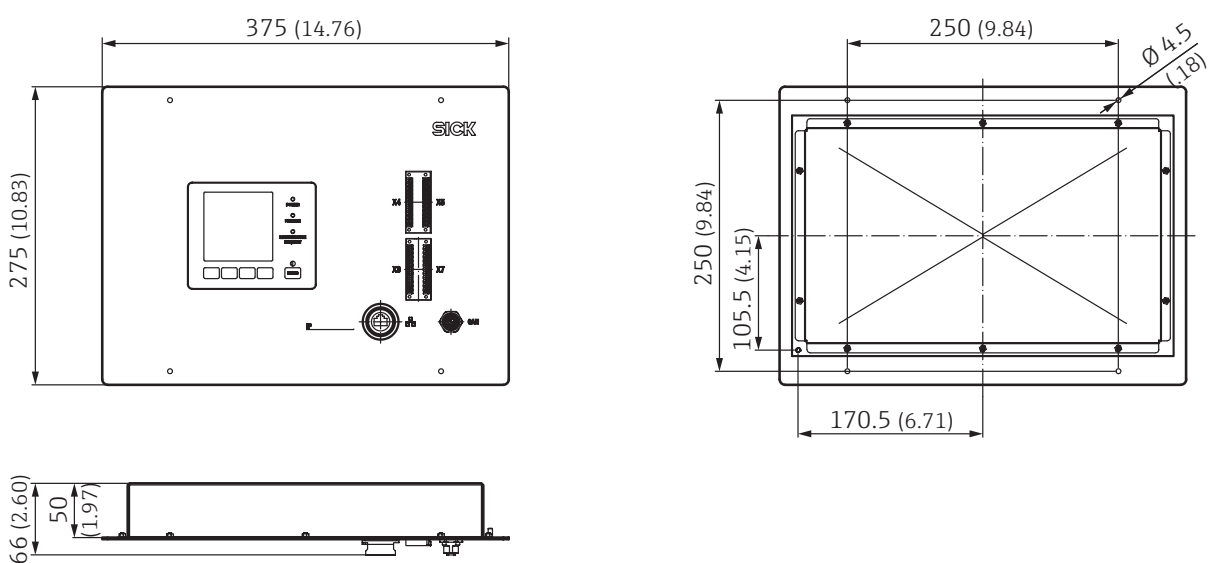

GMS840 FIDOR (dimensions in mm (inch))

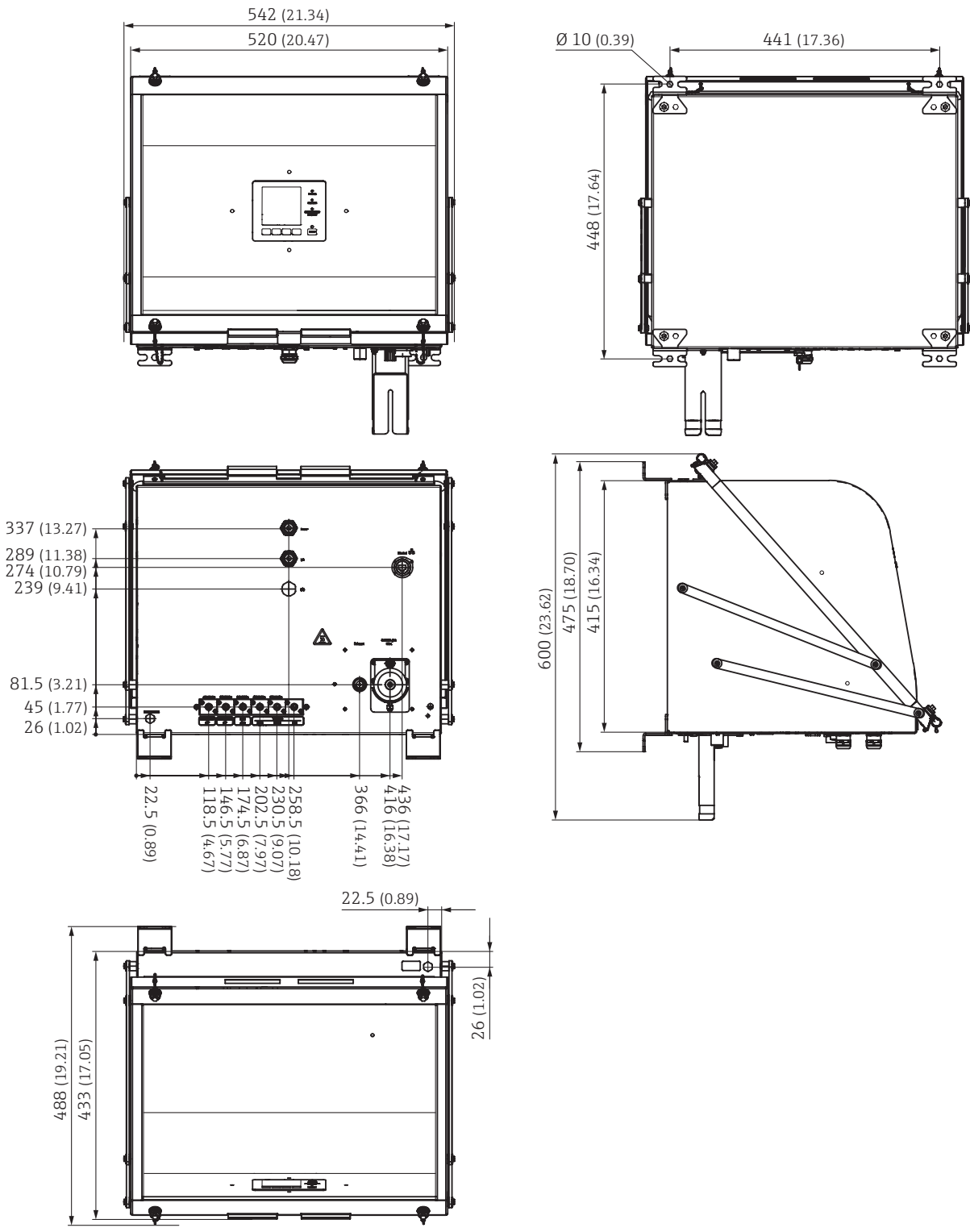

Connection type

GMS810 FIDOR and GMS811 FIDOR: sample gas inlet on the side

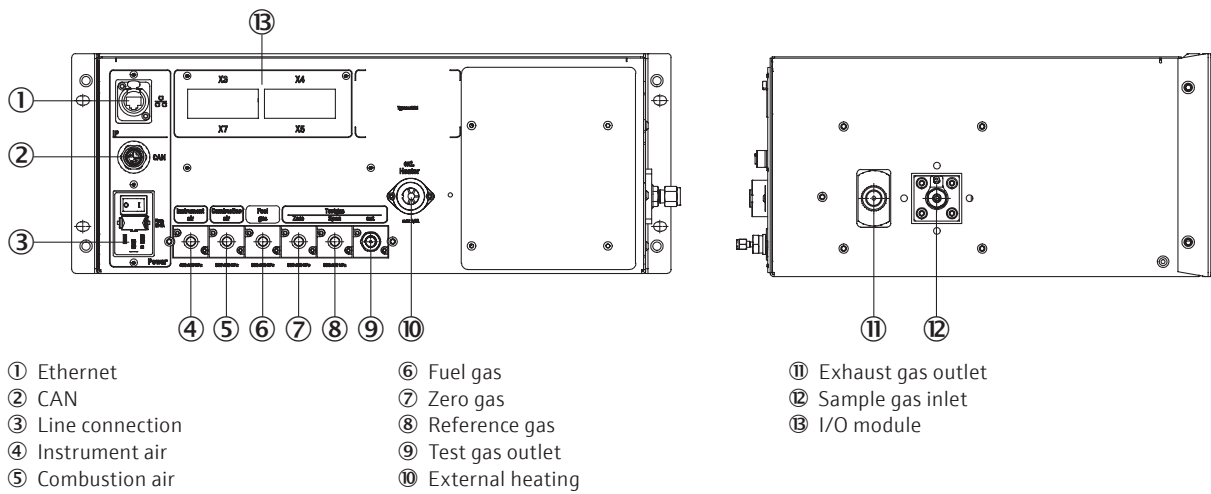

GMS810 FIDOR and GMS811 FIDOR: sample gas inlet on the rear

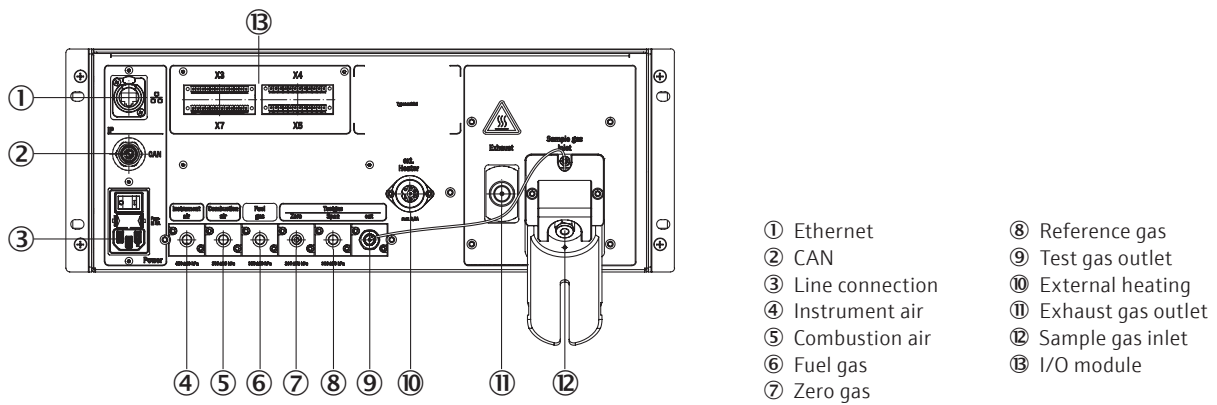

GMS840 FIDOR

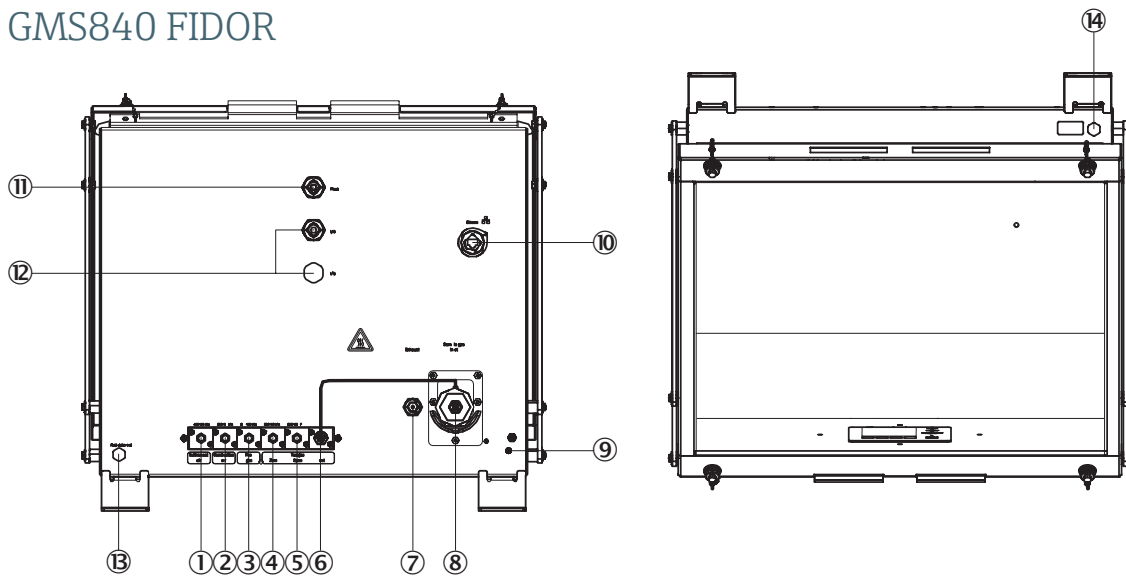

Top view (left) and bottom view (right)

www.addresses.endress.com

IN 8029985 / EHS / EN / 03.00