

# S700

## Extractive Gas Analyzers

### Tailor-made gas analysis for process and emission monitoring

- Simple application-specific configuration thanks to modular design
- Can also be used in Ex Zone 1 and Ex Zone 2
- Automatic readjustment using test gas or calibration cell
- Integrated self-monitoring and error analysis
- Process monitoring for the safety and quality of manufacturing processes and products
- Remote control and integration into distributed control systems thanks to optional equipment with various interface converters



# Custom system solution



With the modular gas analyzer S700, a customer-specific and tailor-made measuring device can be put together for almost every application. Various analyzer modules for the measurement of well over 60 gases, and different housing variants offer comprehensive and individually tailored combination options.

## Application and principle of operation

The modular S700 gas analyzer is used for applications in the biogas sector, for process gas measurement, and for emission measurements. Five different analyzer modules with different measurement principles, along with different housing variants are available for this.

Up to three analyzer modules can be installed in each housing, and optionally two more measured values from external sensors can be processed via analog inputs. A maximum of five measured values can thus be taken into consideration, incorporated into calculations, and displayed and output via a serial interface. Four of these measured values are output via analog outputs. When data are output via a serial interface, all five measured values and additional date, time and status information are available.





Optionally from the calculation of actual measured values, a virtual measured value can be generated, which is displayed and can be brought out on an analog output. All measured values can additionally be provided with alarm-limit values.

The intelligent microprocessor control enables an automated and low maintenance operation with control functions for the industrial measuring devices including all important device functions, such as fully-automated calibration using test gas or calibrated cell (optional).

Self-monitoring and error analysis are also integrated. Operation is menu driven with text on a large LCD display. The S700 can also optionally be equipped with various interface converters for remote control via a network through to integration in distributed control systems.

## Product versions and combination options

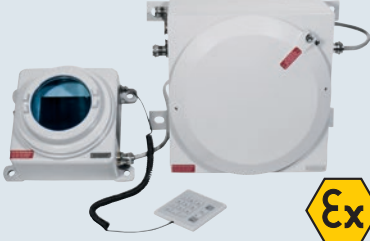
Different housing variants are available depending on the location of use and ambient conditions:

<p><b>S710/S711</b></p>  <p>19" rack housing with 3 rack units for standard applications</p> <ul style="list-style-type: none"> <li>▪ The custom shape S711 with smaller installation depth can be used everywhere that analog old devices should be replaced with new ones</li> </ul>	<p><b>S715 / S715 Ex</b></p>  <p>Wall-mounted housing for use in harsh industrial environments and optionally for Ex zone 2 (ATEX)</p> 	<p><b>S720 Ex/S721 Ex</b></p>  <p>In flameproof enclosure for Ex zone 1 (ATEX)</p>  <ul style="list-style-type: none"> <li>▪ The custom shape S721 Ex has a larger analyzer housing, in order to utilize the max. analyzer combination options</li> </ul>
---	---	---

### One housing can accommodate up to three analyzer modules.

You have various options for combining the available analyzer modules, which differ based on the following measurement principles:

- NDIR spectroscopy (UNOR and MULTOR)
- Electrochemical cell (OXOR-E)
- Paramagnetic dumbbell principle (OXOR-P)
- Thermal conductivity measurement (THERMOR)

Depending on the scope of equipping and application limitations with the combinations are however possible.

### Measurement of flammable gases and explosive gas mixtures

Flammable gases and explosive gas mixtures are important indicators and adjustment parameters for product and process quality in many industrial manufacturing processes. The monitoring of flammable gases and explosive gas mixtures also plays an important role in ensuring compliance with applicable directives and legal requirements for ensuring the safe operation of industrial plants. In gas analysis, the composition of gas mixtures is examined qualitatively and quantitatively using different measurement principles. The choice of measurement principles depends on which gas components need to be measured, and in which gas mixtures. The concentrations and the properties of the relevant gases are also decisive for selecting the ideal measurement technology. In practice, there are a large number of applications that require a combination of different measurement principles. In addition to the gases and gas mixtures to be measured, the places of use and the respective ambient conditions also vary.

The following tasks can be distinguished for which a gas analysis is typically performed:

- Process control to ensure the quality and efficiency of the manufacturing process and product
- Process monitoring for the safety of the process
- Emission monitoring for compliance with legal requirements regarding the composition of exhaust gases.



The versatile S700 gas analyzer can be used for a wide range of applications. More information on the basics of measuring flammable gases and explosive gas mixtures as well as an overview of the available measurement tasks can be obtained from our contact person.

# S700

## Tailor-made gas analysis for process and emission monitoring



### Product description

The S700 modular system facilitates the configuration of bespoke applications. An S700 housing can be equipped with up to three analyzer modules as standard to make compact and cost-effective system solutions a reality. There are different analyzer modules available for analyzing more than 60 gas components. Depending on the measuring task, location of use

and ambient conditions, the following housing shapes are available:

- S710 and S711 as 19" plug-in for analyzer systems and standard applications
- S715 (Ex) as wall-mounted housing for harsh application conditions (optionally for Ex zone 2)
- S720 and S721 as pressure-resistant encapsulated housing for use in Ex zone 1.

### At a glance

- Various analyzer modules are available: UNOR (NDIR), MULTOR (NDIR), OXOR-E (electrochemical O<sub>2</sub>), OXOR-P (paramagnetic O<sub>2</sub>), THERMOR (thermal conductivity)
- Over 60 measuring components to choose from
- Different housing variants for different fields of application
- Up to three analyzer modules in one housing

### Your benefits

- Simple application-specific configuration thanks to modular design
- Can also be used in Zone 1 and Zone 2 (ATEX) explosion-hazardous areas
- Automatic readjustment using test gas or calibration cell
- Integrated self-monitoring and error analysis
- Process monitoring for the safety and quality of manufacturing processes and products by measuring flammable gases and explosive gas mixtures in zones 1 and 2
- Reliable remote control and integration into distributed control systems thanks to optional equipment with various interface converters

### Fields of application

- Cooling gas monitoring of turbo generators
- CO measurement for coal mill monitoring
- H<sub>2</sub> purity measurements in pressure swing adsorption systems
- CO<sub>2</sub> monitoring in natural gas during natural gas processing
- Monitoring of blast furnace gases for optimization
- Efficiency monitoring of the methanation of CO and CO<sub>2</sub> to methane



### More Information online

For more information, enter the link or scan the QR code to get direct access to technical data, operating instructions, software, application examples, and much more.

[www.endress.com/s700](http://www.endress.com/s700)



# Technical data

The precise device specifications and product performance data may vary and are dependent on the respective application and customer specifications.

## S700

Measurands	Ar, CBrF <sub>3</sub> , CClF <sub>3</sub> , CCl <sub>2</sub> F <sub>2</sub> , CCl <sub>3</sub> F, CHClF <sub>2</sub> , CHCl <sub>3</sub> , CH <sub>2</sub> Cl <sub>2</sub> , CH <sub>2</sub> O, CH <sub>3</sub> Cl, CH <sub>3</sub> OH, (CH <sub>3</sub> ) <sub>2</sub> O, CH <sub>4</sub> , CO, CO <sub>2</sub> , CS <sub>2</sub> , C <sub>2</sub> Cl <sub>2</sub> F <sub>4</sub> , C <sub>2</sub> Cl <sub>3</sub> F <sub>3</sub> , C <sub>2</sub> Cl <sub>4</sub> , C <sub>2</sub> HCl <sub>3</sub> , C <sub>2</sub> H <sub>2</sub> , C <sub>2</sub> H <sub>2</sub> Cl <sub>2</sub> , C <sub>2</sub> H <sub>2</sub> F <sub>4</sub> , C <sub>2</sub> H <sub>3</sub> Cl <sub>3</sub> , C <sub>2</sub> H <sub>4</sub> , C <sub>2</sub> H <sub>4</sub> Cl <sub>2</sub> , C <sub>2</sub> H <sub>5</sub> OH, C <sub>2</sub> H <sub>6</sub> , C <sub>3</sub> H <sub>4</sub> , C <sub>3</sub> H <sub>6</sub> , C <sub>3</sub> H <sub>7</sub> OH, C <sub>3</sub> H <sub>8</sub> , C <sub>3</sub> H <sub>8</sub> O <sub>2</sub> , C <sub>4</sub> H <sub>6</sub> , C <sub>4</sub> H <sub>8</sub> , C <sub>4</sub> H <sub>10</sub> , C <sub>4</sub> H <sub>8</sub> O, C <sub>4</sub> H <sub>9</sub> OH, C <sub>5</sub> H <sub>12</sub> , C <sub>6</sub> H <sub>10</sub> O, C <sub>6</sub> H <sub>12</sub> , C <sub>6</sub> H <sub>14</sub> , C <sub>7</sub> H <sub>16</sub> , C <sub>7</sub> H <sub>8</sub> , C <sub>8</sub> H <sub>10</sub> , He, H <sub>2</sub> , H <sub>2</sub> O, NH <sub>3</sub> , NO, N <sub>2</sub> O, O <sub>2</sub> , SF <sub>6</sub> , SO <sub>2</sub>
Suitability-tested measurands	CO, NO, O <sub>2</sub> , SO <sub>2</sub>
Gas flow	
Without integrated sample gas pump:	5 l/h ... 100 l/h (1.32 gal/h ... 26.42 gal/h)
With integrated sample gas pump:	30 l/h ... 60 l/h (7.93 gal/h ... 15.85 gal/h)
Sample gas temperature	0 °C ... +45 °C (32 °F ... 113 °F) Temperature at analyzer input
Process pressure	
Hosed internal gas paths	-20 ... +30 kPa (-2.90 ... +4.35 psi)
Piped internal gas paths	-20 ... +100 kPa (-2.90 ... +14.50 psi)
With "OXOR-E" analyzer module	-20... +30 kPa (-2.90 ... +4.35 psi)
S720 Ex/S721 Ex	-20 ... +10 kPa (-2.90 ... +1.45 psi)
Process gas moisture	Non-condensing
Dust load	Dust- and aerosol-free
Ambient temperature	+5 °C ... +45 °C (41°F ... 113°F)
Storage temperature	-20 °C ... +70 °C (-4°F ... 158°F)
Ambient pressure	700 hPa ... 1,200 hPa (10.15 psi ... 17.40 psi)
Geographic altitude	≤ 2,000 m (6,562 ft) (above sea level)
Ambient humidity	≤ 95%, relative humidity; non-condensing
Electrical safety	CE, CSA (option)
Conformities	Industrial Emissions Directive (IED) Emission measurement according to local guidelines (e.g., CCEP, EPA)
Analog outputs	4 outputs: 0/4 ... 20 mA, 500 Ω; 0 ... 10 V Galvanically isolated
Analog inputs	2 inputs: 0/2/4 ... 20 mA Option: 0 ... 10 V DC
Digital outputs	8 relay contacts: Three relay outputs preallocated to fault, service and maintenance 8 open collector outputs: Freely configurable
Digital inputs	8 optocoupler inputs: Galvanically isolated; freely programmable
Communication interface	Modbus
Type of fieldbus integration	RTU RS-232
Interface converter	Optional: RS485 or Ethernet
Quantity	1
Display	LC display
Operation	Menu-guided operator via LC display and membrane keyboard



Menu language	German, English, French, Italian, Dutch, Polish, Swedish, Spanish
Energy supply	
Voltage	100 V AC / 115 V AC / 230 V AC
Frequency	48 ... 62 Hz
Power consumption	≤ 150 W, depending on the system configuration
Corrective functions	Automated testing and adjustment with test gases Manual adjustment with test gases
Options	Integrated sample gas pump (for tubed gas paths only) Piped gas paths Up to three gas paths Flow sensor Moisture sensor Barometric pressure correction Sample gas pressure correction Measuring point switchover (max. 8 measuring points)

### Type S710

Description	19" rack housing with 3 rack units; for installation in analyzer cabinets
Electrical safety	CE, CSA (option)
Enclosure rating	IP 20
Dimensions (W x H x D)	483 mm x 132,5 mm x 390 mm (19.02 in x 5.22 in x 15.35 in) (see dimensional drawings for details)
Weight	10 kg ... 20 kg (22.05 lbs ... 44.09 lbs), depending on configuration
Sample gas connections	PVDF bulkhead fitting For 6 x 1 mm hose Option: 6 mm Swagelok Option: 1/4" Swagelok

### Type S711

Description	19" rack housing with 3 rack units and reduced depth; for installation in analyzer cabinets
Electrical safety	CE, CSA (option)
Enclosure rating	IP 20
Dimensions (W x H x D)	483 mm x 132,5 mm x 290 mm (19.02 in x 5.22 in x 11.42 in) (see dimensional drawings for details)
Weight	9 kg ... 19 kg (19.8 lbs ... 42 lbs), depending on configuration
Sample gas connections	PVDF bulkhead fitting For 6 x 1 mm hose Option: 6 mm Swagelok Option: 1/4" Swagelok

**Type S715**

Description	Wall-mounted housing with gas-tight separate analysis and electronic units
Electrical safety	CE
Enclosure rating	IP 65 / NEMA 4x
Dimensions (W x H x D)	555 mm x 470 mm x 288 mm (21.85 in x 18.50 in x 11.34 in) (see dimensional drawings for details)
Weight	20 kg ... 30 kg (44.09 lbs ... 66.14 lbs), depending on configuration
Sample gas connections	G1/4" female thread For screw-in connections Option: PVDF compression fitting For 6 x 1 mm hose Option: 6 mm Swagelok Option: 1/4" Swagelok
Auxiliary connections	Purge gas: G1/4" female thread For screw-in connections Option: 8 mm Swagelok Option: 10 mm Swagelok Option: 3/8" Swagelok
Options	Intrinsically safe measured value outputs

**Type S715 Ex**

Description	Wall-mounted housing with gas-tight separate analysis and electronic units
Ex approvals	
	ATEX II 3G Ex nR IIC T6 Gc Without intrinsically safe measured value outputs
	ATEX II 3G Ex nR [ib] IIC T6 Gc With intrinsically safe measured value outputs
Electrical safety	CE
Enclosure rating	IP 65 / NEMA 4x
Dimensions (W x H x D)	555 mm x 470 mm x 288 mm (21.85 in x 18.50 in x 11.34 in) (see dimensional drawings for details)
Weight	20 kg ... 30 kg (44 lbs ... 66 lbs), depending on configuration
Sample gas connections	G1/4" female thread For screw-in connections Option: PVDF compression fitting For 6 x 1 mm hose Option: 6 mm Swagelok Option: 1/4" Swagelok
Auxiliary connections	Purge gas: G1/4" female thread For screw-in connections Option: 8 mm Swagelok Option: 10 mm Swagelok Option: 3/8" Swagelok
Options	Intrinsically safe measured value outputs

**Type S720 Ex**

Description	Pressure-resistant encapsulated housing for use in Ex zone 1
Ex approvals	
	ATEX II 2G Ex db ia IIC T6 Gb Without intrinsically safe measured value outputs
	ATEX II 2G Ex db ia [ia] IIC T6 Gb With intrinsically safe measured value outputs
Electrical safety	CE
Enclosure rating	IP 65 / NEMA 7
Dimensions (W x H x D)	480 mm x 480 mm x 276 mm (18.90 in x 18.90 in x 10.87 in) (see dimensional drawings for details)
Weight	60 kg ... 70 kg (132 lbs ... 154 lbs), depending on configuration
Sample gas connections	G1/4" female thread For screw-in connections Option: PVDF compression fitting For 6 x 1 mm hose Option: 6 mm Swagelok Option: 1/4" Swagelok
Auxiliary connections	Purge gas: G1/4" female thread For screw-in connections
Options	Intrinsically safe measured value outputs

**Type S721 Ex**

Description	Pressure-resistant encapsulated housing for use in Ex zone 1 with large analyzer unit for maximum system configuration
Ex approvals	
	ATEX II 2G Ex db ia IIC T6 Gb Without intrinsically safe measured value outputs
	ATEX II 2G Ex db ia [ia] IIC T6 Gb With intrinsically safe measured value outputs
Electrical safety	CE
Enclosure rating	IP 65 / NEMA 7
Dimensions (W x H x D)	596 mm x 480 mm x 300 mm (23.46 in x 18.90 in x 11.81 in) (see dimensional drawings for details)
Weight	90 kg ... 100 kg (198 lbs ... 220.5 lbs), depending on configuration
Sample gas connections	G1/4" female thread, for screw-in connections Option: PVDF compression fitting For 6 x 1 mm hose Option: 6 mm Swagelok Option: 1/4" Swagelok
Auxiliary connections	Purge gas: G1/4" female thread For screw-in connections
Options	Intrinsically safe measured value outputs



## UNOR analyzer module

Description	Highly selective NDIR analyzer for continuous measurement of IR active gas components
Measurement principles	NDIR spectroscopy
Measuring ranges	
	CH <sub>4</sub> 0 ... 100 ppm / 0 ... 100 Vol.-%
	C <sub>2</sub> H <sub>2</sub> 0 ... 300 ppm / 0 ... 100 Vol.-%
	C <sub>2</sub> H <sub>4</sub> 0 ... 300 ppm / 0 ... 100 Vol.-%
	C <sub>2</sub> H <sub>6</sub> 0 ... 100 ppm / 0 ... 100 Vol.-%
	C <sub>2</sub> H <sub>2</sub> Cl <sub>2</sub> 0 ... 500 ppm / 0 ... 30 Vol.-%
	C <sub>3</sub> H <sub>6</sub> 0 ... 300 ppm / 0 ... 100 Vol.-%
	C <sub>3</sub> H <sub>8</sub> 0 ... 100 ppm / 0 ... 100 Vol.-%
	C <sub>4</sub> H <sub>10</sub> 0 ... 100 ppm / 0 ... 100 Vol.-%
	C <sub>5</sub> H <sub>12</sub> 0 ... 300 ppm / 0 ... 100 Vol.-%
	C <sub>6</sub> H <sub>14</sub> 0 ... 300 ppm / 0 ... 10 Vol.-%
	CO 0 ... 20 ppm / 0 ... 100 Vol.-%
	CO <sub>2</sub> 0 ... 10 ppm / 0 ... 100 Vol.-%
	Frigen 11, CCl <sub>3</sub> F 0 ... 500 ppm / 0 ... 50 Vol.-%
	Frigen 134a, C <sub>2</sub> H <sub>2</sub> F <sub>4</sub> 0 ... 100 ppm / 0 ... 100 Vol.-%
	Frigen 22, CHClF <sub>2</sub> 0 ... 100 ppm / 0 ... 100 Vol.-%
	NH <sub>3</sub> 0 ... 300 ppm / 0 ... 100 Vol.-%
	NO 0 ... 75 ppm / 0 ... 100 Vol.-%
	N <sub>2</sub> O 0 ... 50 ppm / 0 ... 100 Vol.-%
	SF <sub>6</sub> 0 ... 50 ppm / 0 ... 100 Vol.-%
	SO <sub>2</sub> 0 ... 75 ppm / 0 ... 100 Vol.-%
	Over 60 different measuring components to choose from
Adjustment time (t <sub>90</sub> )	3 s; typical at 60 l/h ((15.85 gal/h)), depending on the cell length and the gas flow rate
Sensitivity drift	≤ 1% of the measuring range limit value per week
Zero point drift	≤ 1% of the smallest measuring range per week
Material in contact with media	Stainless steel, aluminum, gold, CaF <sub>2</sub> , BaF <sub>2</sub> , PVDF, FKM, FFKM, 2-component special adhesive
Corrective functions	Manual or automatic adjustment using test gases or adjustment cell

**MULTOR analyzer module**

Description	Multi-component NDIR analyzer for continuous measurement of up to 3 IR absorbing gases and H <sub>2</sub> O for internal cross sensitivity correction
Measurement principles	NDIR spectroscopy
Measuring ranges	
	CH <sub>4</sub> 0 ... 470 ppm / 0 ... 100 Vol.-%
	CO 0 ... 160 ppm / 0 ... 100 Vol.-%
	CO <sub>2</sub> 0 ... 100 ppm / 0 ... 100 Vol.-%
	NO 0 ... 190 ppm / 0 ... 100 Vol.-%
	SO <sub>2</sub> 0 ... 85 ppm / 0 ... 100 Vol.-%
Adjustment time (t <sub>90</sub> )	≤ 25 s; at 60 l/h (15.85 gal/h), depending on the cell length, gas flow rate, and number of measuring components
Sensitivity drift	≤ 1% of the measuring range limit value per week
Zero point drift	≤ 1% of the smallest measuring range per week
Material in contact with media	Stainless steel, aluminum, gold, CaF <sub>2</sub> , BaF <sub>2</sub> , PVDF, FKM, FFKM, 2-component special adhesive
Corrective functions	Manual or automatic adjustment using test gases or adjustment cell

**OXOR-E analyzer module**

Description	Determination of the oxygen content using an electrochemical cell
Measurement principles	Electrochemical cell
Measuring ranges	
	O <sub>2</sub> 0 ... 10 by vol. / 0 ... 25% by vol
Adjustment time (t <sub>90</sub> )	20 s; typical at 60 l/h (15.85 gal/h), depending on the gas flow rate
Sensitivity drift	≤ 1% of the measuring range limit value per week
Zero point drift	≤ 2% of the smallest measuring range per month
Material in contact with media	Stainless steel, PVDF, FKM, FEP
Corrective functions	Manual or automatic adjustment using test gases

**OXOR-P analyzer module**

Description	Accurate oxygen analyzer that operates according to the paramagnetic measurement principle
Measurement principles	Paramagnetic dumbbell principle
Measuring ranges	
	O <sub>2</sub> 0 ... 1 Vol.-% / 0 ... 100 Vol.-%
	Optional: suppressed measuring ranges up to 95 ... 100 Vol.-%
Adjustment time (t <sub>90</sub> )	≤ 4 s; at 60 l/h (15.85 gal/h) gas flow rate
Sensitivity drift	≤ 1% of the measuring range limit value per week
Zero point drift	≤ 1% of the smallest measuring range per week Measuring range less than 5 Vol%: ≤ 0,05 Vol.-% per week
Material in contact with media	Glass, stainless steel, PVDF, FKM, platinum, nickel
Corrective functions	Manual or automatic adjustment using test gases
Note	Special types are available with particularly solvent-resistant or particularly corrosion-resistant measuring chambers

**THERMOR analyzer module**

Description	Thermal conductivity analyzer for determining concentrations in binary or quasi-binary gas mixtures
Measurement principles	Thermal conductivity measurement
Measuring ranges	
	H <sub>2</sub> in Ar 0 ... 1 Vol.-% / 0 ... 100 Vol.-%
	H <sub>2</sub> in CH <sub>4</sub> 0 ... 1 Vol.-% / 0 ... 100 Vol.-%
	H <sub>2</sub> in CO <sub>2</sub> 0 ... 1 Vol.-% / 0 ... 100 Vol.-%
	H <sub>2</sub> in furnace gas 0 ... 1 Vol.-% / 0 ... 100 Vol.-%
	H <sub>2</sub> in N <sub>2</sub> 0 ... 1 Vol.-% / 0 ... 100 Vol.-%
	H <sub>2</sub> in O <sub>2</sub> 0 ... 1 Vol.-% / 0 ... 100 Vol.-%
	Other measuring ranges and components on request
Adjustment time (t <sub>90</sub> )	≤ 20 s; at 60 l/h (15.85 gal/h) gas flow rate
Sensitivity drift	≤ 1% of the measuring range limit value per week
Zero point drift	≤ 1% of the smallest measuring range per week
Material in contact with media	Glass, stainless steel, PVDF, 2-component special adhesive
Corrective functions	Manual or automatic adjustment using test gases

# Ordering information

Our regional sales organization will help you to select the optimum device configuration.

# Dimensional drawings

Types S710 and S711 (dimensions in mm (inch))

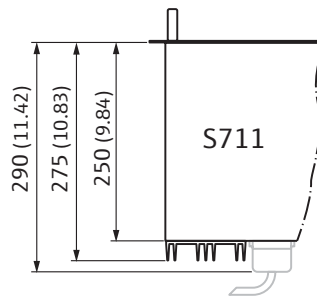
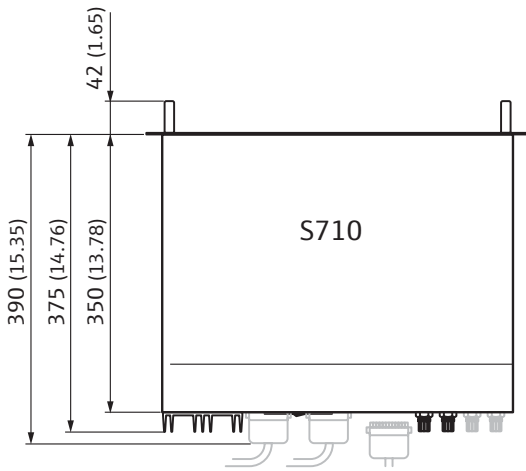
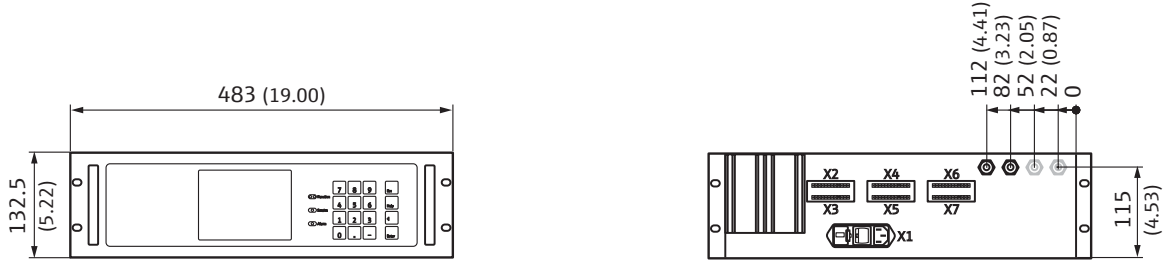

# Type S715 (dimensions in mm (inch))

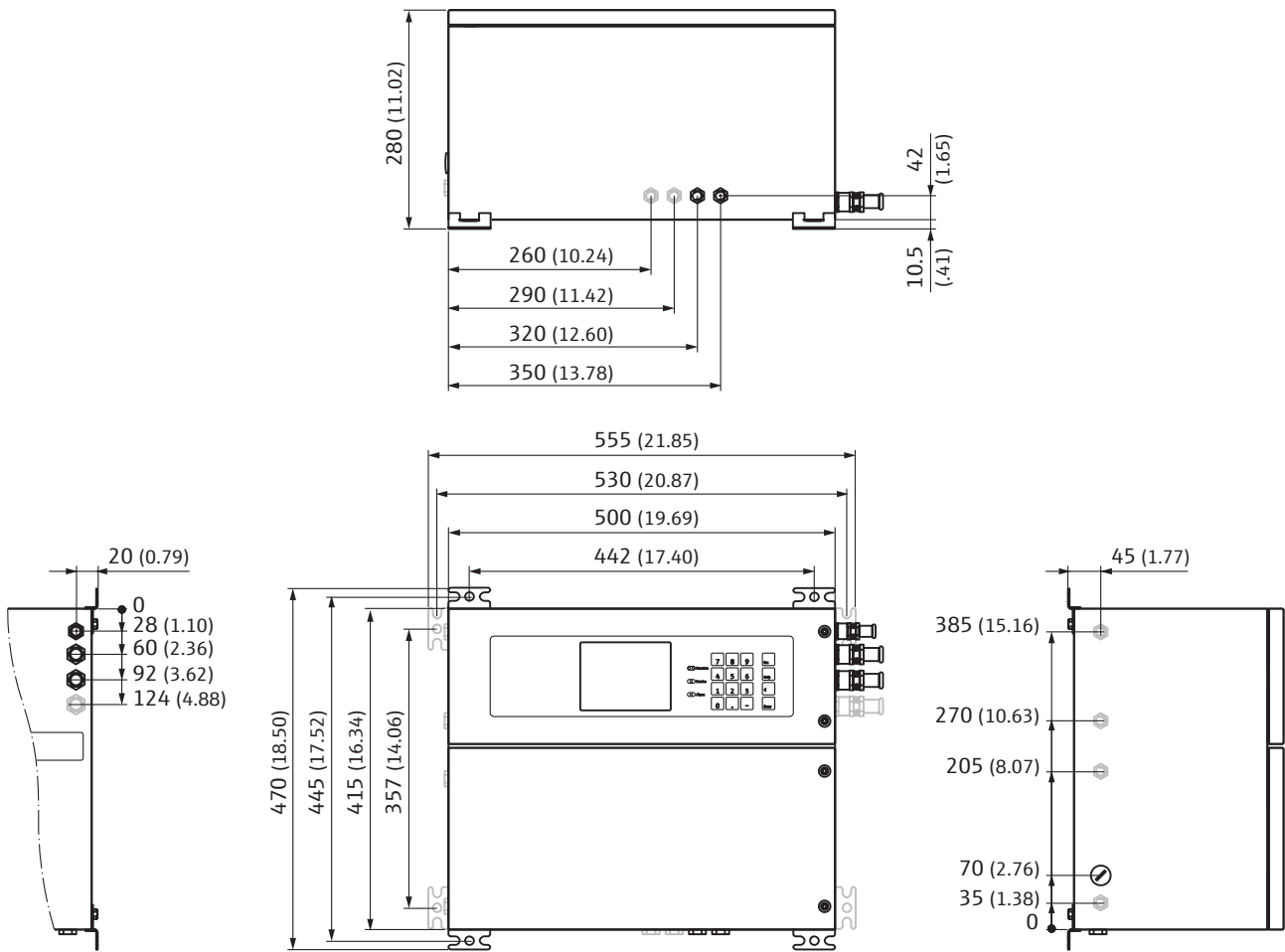

# Type S720 Ex (dimensions in mm (inch))

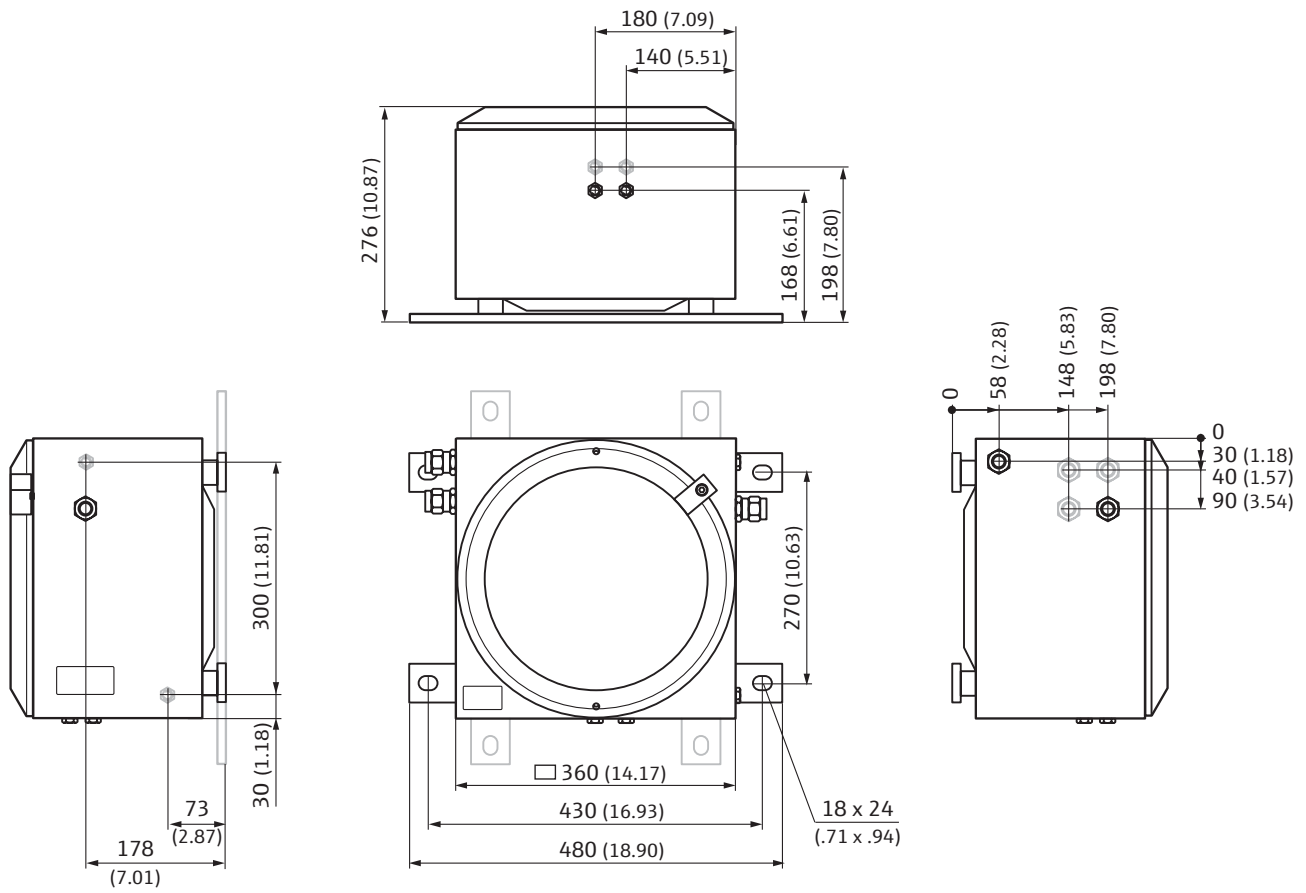



# Type S721 Ex (dimensions in mm (inch))

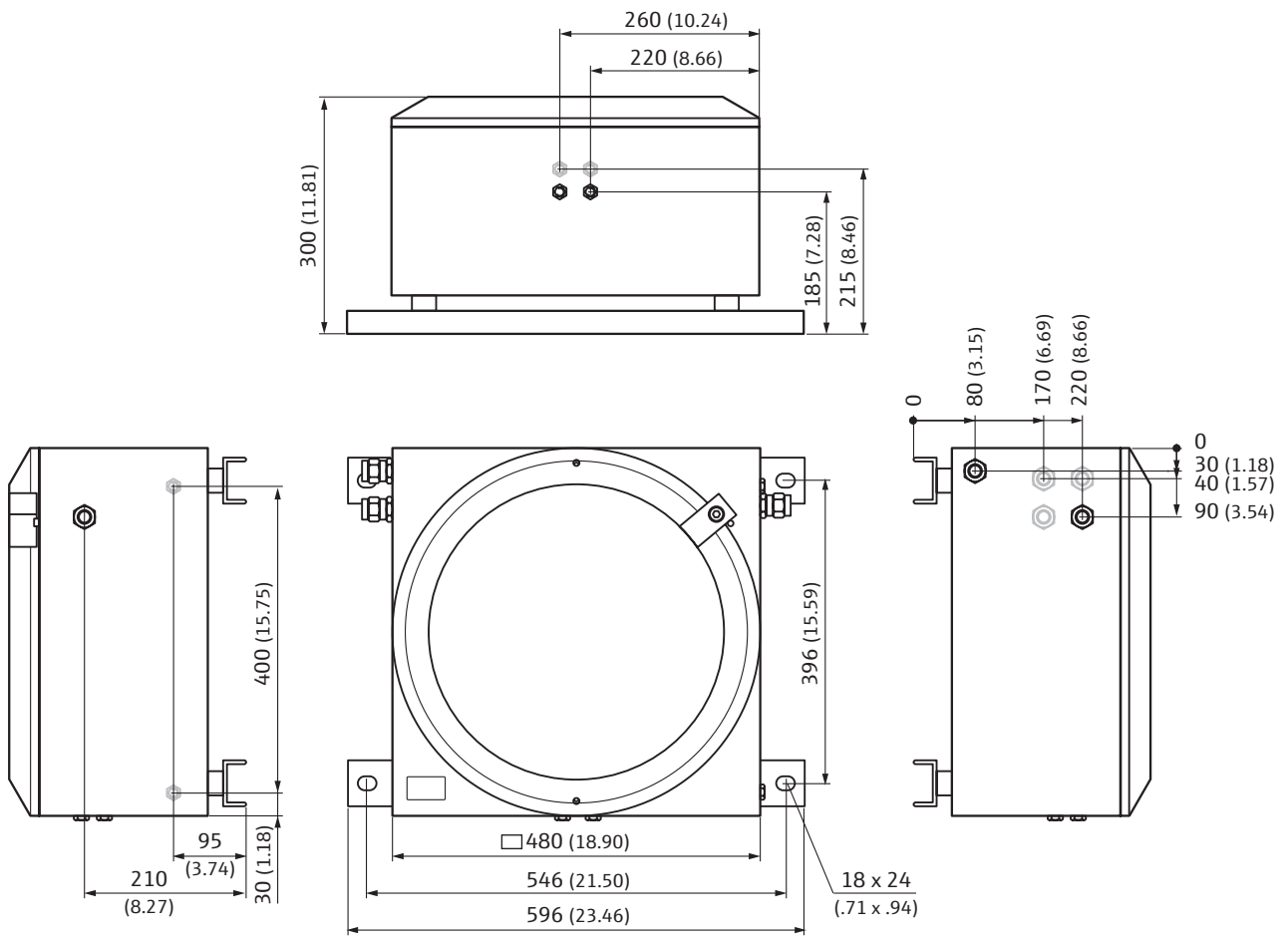

Display and keyboard for type S720 Ex and S721 Ex  
 (dimensions in mm (inch))

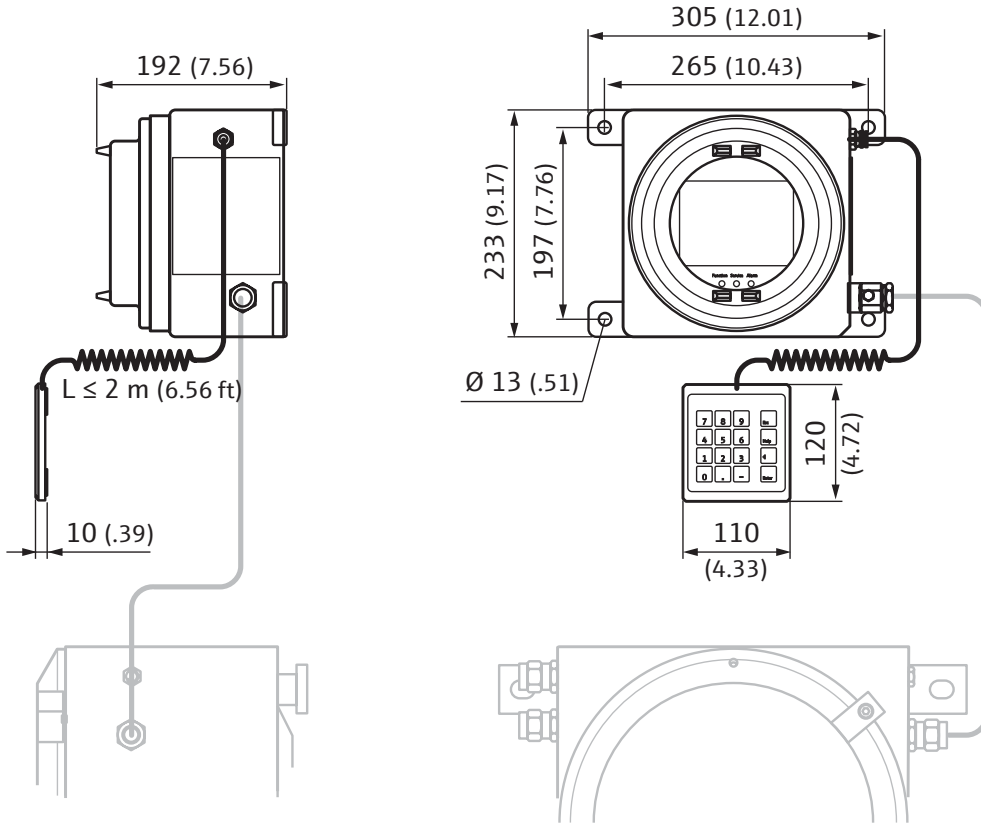







[www.addresses.endress.com](http://www.addresses.endress.com)

---

Eco-friendly produced and printed on paper  
from sustainable forestry.

IN 8030000 / EHS / EN / 04.00