

Operating Instructions

GM32

In-situ Gas Analyzer,
Measuring Probe Version



Described product

Product name: GM32
Variants: GM32 GMP (certified according to EN 15267)
GM32 LowNOx GMP (certified according to EN 15267)
GM32 GPP
GM32 LowNOx GPP
GM32 TRS-PE GPP

Manufacturer

Endress+Hauser SICK GmbH+Co. KG
Bergener Ring 27
01458 Ottendorf-Okrilla
Deutschland

Legal information

This work is protected by copyright. Any rights derived from the copyright shall be reserved for Endress+Hauser SICK GmbH+Co. KG. Reproduction of this document or parts of this document is only permissible within the limits of the legal determination of Copyright Law. any modification, shortening or translation of this document is prohibited without the express written permission of Endress+Hauser SICK GmbH+Co. KG.

The trademarks stated in this document are the property of their respective owner.

© Endress+Hauser SICK GmbH+Co. KG. All rights reserved.

Original document

This document is an original document of Endress+Hauser SICK GmbH+Co. KG.



1	About this document.....	6
1.1	Symbols and document conventions	6
1.1.1	Warning symbols.....	6
1.1.2	Warning levels / signal words	6
1.1.3	Information symbols	7
1.2	Main instructions for operation	7
1.3	Intended use	7
1.3.1	Purpose of the device.....	7
1.4	Product identification.....	7
1.5	Responsibility of user.....	7
1.6	Additional documentation/information.....	8
2	Product description	9
2.1	Product description.....	9
2.1.1	Device versions.....	9
2.1.2	TRS calculation	10
2.1.3	Device variants	10
2.1.4	Options	11
2.2	SOPAS ET (PC program)	11
2.3	Reference cycle.....	11
2.4	Check cycle.....	11
2.5	GM32 design	13
2.5.1	Measuring probe.....	13
2.6	Purge air unit (for GMP measuring probe)	13
2.6.1	Light sources.....	14
3	Preparing the gas duct side	15
3.1	Preparing the sampling point	15
3.1.1	Checking the scope of delivery	15
3.2	Overview of the installation steps (duct-side work).....	16
3.2.1	Work steps (overview)	17
3.2.2	Installing the flange with tube on the gas duct	17
3.3	Installing the connection unit.....	18
3.4	Installing the purge air unit (for GMP probe)	18
3.5	Laying the electrical connection lines	19
3.5.1	General information.....	21
3.5.2	Connecting I/O interfaces (option).....	21
3.5.2.1	Default values for interfaces	22
3.5.3	Laying the electrical connection lines to the SR-unit.....	23
3.5.4	Preparing the power supply.....	24
4	Start-up.....	25
4.1	Necessary technical knowledge for start-up.....	25
4.2	Required material (not included in the scope of delivery)	27
4.3	Overview of assembly steps	28

- 4.4 Transport safety devices 29
- 4.5 Installing the device flange on the purge air fixture 30
- 4.6 Aligning the measuring probe in flow direction 31
 - 4.6.1 When the probe alignment has to be set 31
- 4.7 For the GPP probe: Electrical connection 32
- 4.8 Electrical connection of the SR-unit 33
- 4.9 Switching on the power supply of the GM32 33
- 4.10 For GMP probe: Start-up of the purge air supply 33
- 4.11 Installing the measuring probe in the gas duct 34
- 4.12 Installing the SR-unit on the device flange 36
- 4.13 Optical fine alignment of the SR-unit 36
- 4.14 OPC 37
 - 4.14.1 OPC interface 38
- 4.15 Installing weatherproof covers (option) 39

- 5 Operation 41**
 - 5.1 Recognizing an unsafe operating state 41
 - 5.2 Operator panel 42
 - 5.2.1 Status indicators (LEDs) 42
 - 5.2.2 Button assignment 42
 - 5.2.3 Contrast setting 42
 - 5.2.4 Language 43
 - 5.2.5 Menu tree 43
 - 5.2.5.1 Diagnosis 44
 - 5.2.5.2 Check cycle 45
 - 5.2.5.3 Alignment check (automatic optical alignment check; option) 45
 - 5.2.5.4 Adjustments 45
 - 5.2.5.5 Maintenance 47







- 6 Maintenance 48**
 - 6.1 Maintenance plan (operator) 48
 - 6.1.1 Recommended expendable and wearing parts for 2 years operation 48
 - 6.2 Preparation work 48
 - 6.3 Swiveling out and removing the SR-unit 49
 - 6.4 Visual inspection 49
 - 6.5 Cleaning the window 50
 - 6.6 Checking and replacing the desiccant cartridges 50
 - 6.7 Replacing the sender lamp and LED for GM32 LowNOx 51
 - 6.7.1 Tools required 51
 - 6.7.2 Sender lamp with LED unit 51
 - 6.8 Cleaning the purge air unit 53

7	Clearing malfunctions	54
7.1	Safety instructions when clearing malfunctions	54
7.2	Error diagnosis Tables	55
7.2.1	Device not functioning	55
7.2.2	Measured values clearly incorrect	55
7.2.3	Sample gas penetrating	55
7.2.4	Corrosion on probe or flanges	56
7.2.5	Measured value blinks	56
7.3	Error messages	56
7.3.1	Example of an error message	56
7.3.2	Error messages	57
7.4	Inadequate purge air supply (for GMP probe)	61
7.5	Malfunctions on the connection unit	61
8	Shutdown	62
8.1	Shutdown	62
8.1.1	Shutdown	62
8.1.2	Disassembly	62
8.2	Storage	63
8.3	Environmentally compatible disposal/recycling	63
9	Specifications	64
9.1	Conformities	64
9.1.1	Electrical protection	64
9.2	System: GM32	65
9.2.1	System GM32 Standard	65
9.2.2	System GM32 TRS-PE	66
9.2.3	Sender/receiver unit	67
9.2.4	Open measuring probe (GMP)	67
9.2.5	Gas-testable measuring probe (GPP)	67
9.2.6	Connection unit	68
9.3	Modbus Register Mapping	69
9.3.1	Mapping of GM32 measuring components	69
9.3.2	Mapping for GM32 in general	70
9.3.3	Mapping of Modbus input values	71
9.3.4	Table Bitmap "Status"	71
9.3.5	Bitmap Table "Failure"	72
9.3.6	Bitmap Table "Maintenance Request"	72
9.3.7	Bitmap Table Function "Check" and "Out of Specification"	72
9.3.8	Bitmap Table "Extended"	73
9.3.9	Table "Operating States"	73
9.4	Dimensions	74

1 About this document

1.1 Symbols and document conventions

1.1.1 Warning symbols

Symbol	Significance
	Hazard (general)
	Hazard by voltage
	Hazard by explosive substances/mixtures
	Hazard by unhealthy substances
	Hazard by high temperature or hot surface
	Hazard for the environment/nature/organic life

1.1.2 Warning levels / signal words

DANGER

Risk or hazardous situation which will result in severe personal injury or death.

WARNING

Risk or hazardous situation which *could* result in severe personal injury or death.



CAUTION

Hazard or unsafe practice which could result in less severe or minor injuries.



NOTICE

Hazard which could result in property damage.

1.1.3 Information symbols

Symbol	Significance
	Important technical information for this product
	Important information on electric or electronic functions

1.2 Main instructions for operation

	<p>WARNING: Danger resulting from escaping gas when the SR-unit is swiveled out</p> <p>Excess pressure in the gas duct can cause hot and/or noxious gases to escape when the SR-unit is swiveled out.</p> <ul style="list-style-type: none"> ▶ Swivel the SR-unit out only when you have taken suitable safety measures.
	<p>CAUTION: If the hinge pin has not been correctly inserted, the SR-unit can drop when swiveled out.</p> <ul style="list-style-type: none"> ▶ Check the hinge pin is completely pressed down before swiveling the SR-unit out (see “Install the SR-unit:”, page 36).
	<p>CAUTION: Danger of contamination caused by purge air failure (for GM32 with GMP probe)</p> <ul style="list-style-type: none"> ▶ If a failure of the purge air supply occurs, take immediate measures to protect the measuring system (see “Error messages”, page 56).

1.3 Intended use

1.3.1 Purpose of the device

The GM32 serves exclusively for emission and process monitoring of gases in industrial plants.

GM32 measures continuously directly in the gas duct (in-situ).

1.4 Product identification

Product name	GM32
Product variant	Version with measuring probe
Manufacturer	Endress+Hauser SICK GmbH+Co. KG Bergener Ring 27 · 01458 Ottendorf-Okrilla · Germany
Location of type plates	Sender/receiver unit: On the right side and on the intermediate enclosure Connection unit: On the right side and inside For GMP probe: On the purge air fixture For GPP probe: On the flange fixture

1.5 Responsibility of user

Designated users

The GM32 may be operated by competent persons only who, based on their device-specific training and knowledge of the device as well as knowledge of the relevant regulations, can assess the tasks given and recognize the dangers involved.

Correct use

- ▶ Use the device only as described in these Operating Instructions.
The manufacturer bears no responsibility for any other use.
- ▶ Perform the specified maintenance work.
- !▶ Do not remove, add or modify any components to or on the device unless described and specified in the official manufacturer information.
Otherwise:
 - Any warranty by the manufacturer becomes void.
 - The device could become dangerous.

Special local conditions

- ▶ Follow all local laws, regulations and company-internal operating directives applicable at the installation location.

Retention of documents

These Operating Instructions:

- ▶ Must be available for reference.
- ▶ Must be passed on to new owners.

1.6 Additional documentation/information

- ▶ Pay attention to the supplied documents.

Additional instructions

The following documents are applicable in addition to these Operating Instructions:

- Technical Information GM32 (option)
- Operating Instructions for purge air supply SLV4 (for GMP probe)
- Operating Instructions, "Modular I/O System" (option)
- Final inspection record
- CD-ROM with SOPAS ET

2 Product description

2.1 Product description

The GM32 gas analyzer serves for continuous measurement of gas concentrations in industrial plants.

GM32 is an in-situ measuring system which means measuring is done directly in the gas carrying duct.

- Measuring components: SO₂, NO, NO₂ and NH₃ (device specific) as well as the reference variables temperature and pressure.
- GM32-TRS-PExx version: TRS components.
(Only for kraft pulp mills. Only with GPP probe)
- Measuring principle: Differential Optical Absorption Spectroscopy (DOAS).

2.1.1 Device versions

Version	Components measured	Component calculated
All	T, p	---
GM32-1	SO ₂	---
GM32-2	SO ₂ , NO	NO _x
GM32-3	SO ₂ , NO, NO ₂	NO _x
GM32-4	NO	NO _x
GM32-5	SO ₂ , NO, NH ₃	NO _x
GM32-6	NO, NO ₂ , NH ₃	NO _x
GM32-7	NO, NO ₂	NO _x
GM32-8	NO, NH ₃	NO _x
GM32-9	SO ₂ , NO, NO ₂ , NH ₃	NO _x
GM32-TRS-PE01	H ₂ S	---
GM32-TRS-PE02	TRS ^[1]	TRS = H ₂ S+CH ₃ SH
GM32-TRS-PE03	H ₂ S, SO ₂ , NO	---
GM32-TRS-PE04	TRS, SO ₂ , NO	TRS = H ₂ S+CH ₃ SH
GM32-TRS-PE05	H ₂ S, SO ₂ , NO, NH ₃	---
GM32-TRS-PE06	TRS, SO ₂ , NO, NH ₃	TRS = H ₂ S+CH ₃ SH
GM32-TRS-PE07	TRS, H ₂ S, CH ₃ SH ^[2] , -(CH ₃) ₂ S ^[3] , (CH ₃) ₂ S ₂ ^[4] , SO ₂ , NO, NH ₃	TRS = H ₂ S+CH ₃ SH+ (CH ₃) ₂ S+2x(CH ₃) ₂ S ₂

[1] Total reduced sulfurs

[2] Methyl mercaptan

[3] Dimethyl sulphide

[4] Dimethyl disulphide

2.1.2 TRS calculation

Converting TRS physical units ppm <-> mg/m³

- TRS single components are conventionally oxidized thermally in the converter to SO₂.
- The SO₂ difference in ppm from measurement before and after correction results from the TRS components.
- The direct measuring method of the GM32 (without converter) is adapted to this calculation convention.
- Since the H₂S share on TRS is > 80%:
The molecular weight of H₂S serves as basis for converting the SO₂ difference to TRS in mg/m³N.

Example:

- SO₂ difference converter: 10 ppm = 15.18 mg/m³N
- GM32 TRS measured value: 20 mg/m³N = 13.18 ppm
- with H₂S = 34 g/mol
-> 1 ppm H₂S = 34000 mg/mol / 0.0224 m³N/mol / 1000000 = 1.518 mg/m³N
(under normal condition 0 °C).

2.1.3 Device variants

“Basic” variant

- Reference cycle (see “Reference cycle”, page 11): Correction of internal drifts. Zero point check.
- Automatic mirror tracking: Automatic adjustment of optical axis.
- Logbook: System messages are recorded in a logbook.
- Network: Ethernet interface (Modbus TCP, SOPAS ET, OPC server).

“Pro” variant

As “Basic” variant. In addition:

- TÜV performance tested for equipment subject to authorization (→ Technical Data).
- Check cycle, see “Check cycle”, page 11 : Reference cycle (as in the “Basic” variant), followed by a cycle to check and output the zero and check point.
The check cycle creates the QAL3 values (quality assurance of automated measuring systems). The QAL3 values can be displayed with SOPAS ET.
- Operator panel: Measured values, operational state and malfunction messages are displayed in clear text on a monitor.
- QAL3 Tool (CUSUM chart).

2.1.4 Options

- I/O modules:
 - Analog Out: Up to 8 outputs
 - Analog In: Up to 2 inputs
 - Digital Out: Up to 8 outputs
 - Digital In: Up to 4 inputs
- Ethernet rail switch. Contains additional interfaces:
 - 4 electrical connections
 - 1 fiber optics connection (sender and receiver)
- SCU: Operating unit to control several analyzers with SCU capability (→ SCU Operating Instructions).
- Additional measuring range for a component (multi-range calibration)
- Extended gas temperature range up to 650 °C
- LowNO₂ for improved NO₂ precision
- Weatherproof cover

2.2 SOPAS ET (PC program)

SOPAS ET can be used to set the GM32 parameters and provides access to the GM32 logbook.

SOPAS ET runs on an external PC connected via the Ethernet interface to which the GM32 is connected, see [“Laying the electrical connection lines”, page 19](#).



Further information on SOPAS ET:
→ Technical Information GM32
→ SOPAS ET Help menu

2.3 Reference cycle

Internal drifts correction in an adjustable interval (standard: 1 hour, setting: SOPAS ET) or per command (with SOPAS ET).

Measured value output during the reference cycle: Last valid measured value.

2.4 Check cycle

The check cycle comprises the reference cycle, followed by the check and output of the zero and check point (70% of FS).

It is performed in an adjustable interval (with SOPAS ET), via a command (with SOPAS ET) or via an external signal (option).

With the check cycle, the device is capable of checking the zero point and a span point for each component without feeding test gases. The check cycle meets the requirements of EN14181 and makes drift monitoring with test gases according to QAL3 unnecessary.

- Zero point
An internal zero point reflector is swiveled in time-controlled in adjustable intervals. The emitted light is reflected back in the sender/receiver unit to the detector, the zero spectrum is evaluated with the calibration function and thus the zero points of all ducts measured and output.
If the deviation from zero is > ±2% of the FS, *Maintenance request* is signaled.
- Check point

An internal swivel element with two reference filters and an NO-filled cell is swiveled in during the check cycle in addition to the zero point reflector and the reference value or concentration value measured. These control values are scaled to 70% of the selected measuring range.

Maintenance request is signaled if the deviation from the setpoint value is $> \pm 2\%$ of the FS.

Fig. 1: Check point

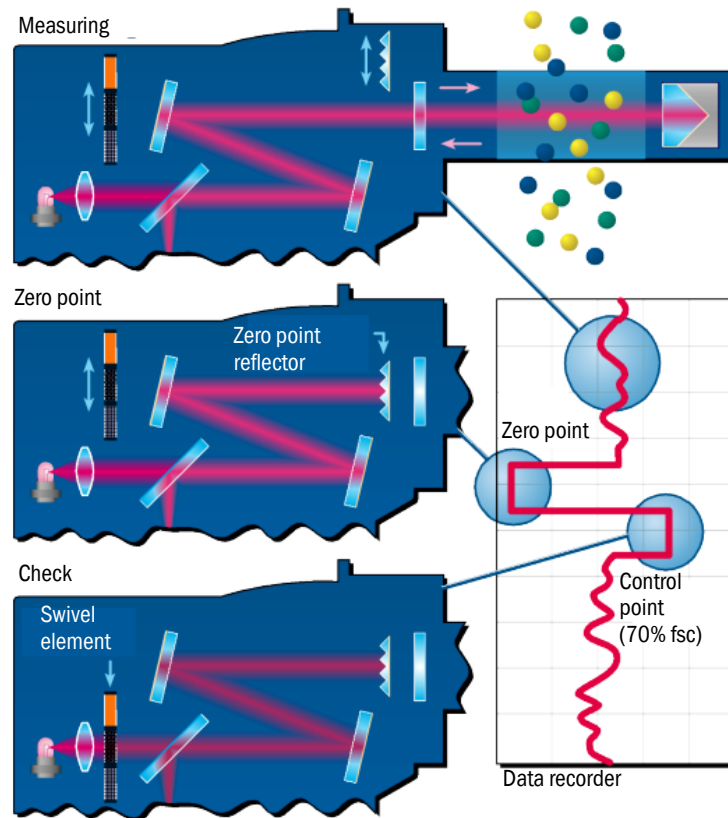

- Output of measured values during the check cycle: Last valid measured value.
- Signal during the check cycle: *Not_measuring*. (Optionally digital output or OPC interface).
- The determined zero and reference values can be output on analog outputs depending on the parameter settings:
 - Directly after the check cycle.
 - On request (via a digital input, option).
 - Signal during output: *Output_control_values*. (Optionally digital output or OPC interface).
 - First output of zero values for 90 s.
 - Then output of reference values for 90 s.
- The zero and reference values of the last check cycle are displayed in SOPAS ET (menu: *Diagnosis/Check values*). The required QAL3 values can be read there.
- NO cell check failed:
 - NO cell results are output on all interfaces.
 - "0" is output on all interfaces instead of the zero and reference values.
 - The analog output shows "Live Zero".
 - Zero and span point measurement results are irrelevant.

2.5 GM32 design

The GM32 Probe version comprises

- Sender/receiver unit (SR-unit)
The SR-unit contains optical and electronic subassemblies.
The concentration calculation of the sample gas is performed in the SR-unit according to the absorption spectroscopy principle.
- Measuring probe with flange or purge air fixture, see “Measuring probe”, page 13.
- Purge air unit (for GMP measuring probe), see “Purge air unit (for GMP measuring probe)”.
- Connection unit, see “Installing the connection unit”, page 18 and see “Electrical connection diagram”, page 19.

Fig. 2: GM32 Probe (version shown: GMP measuring probe)

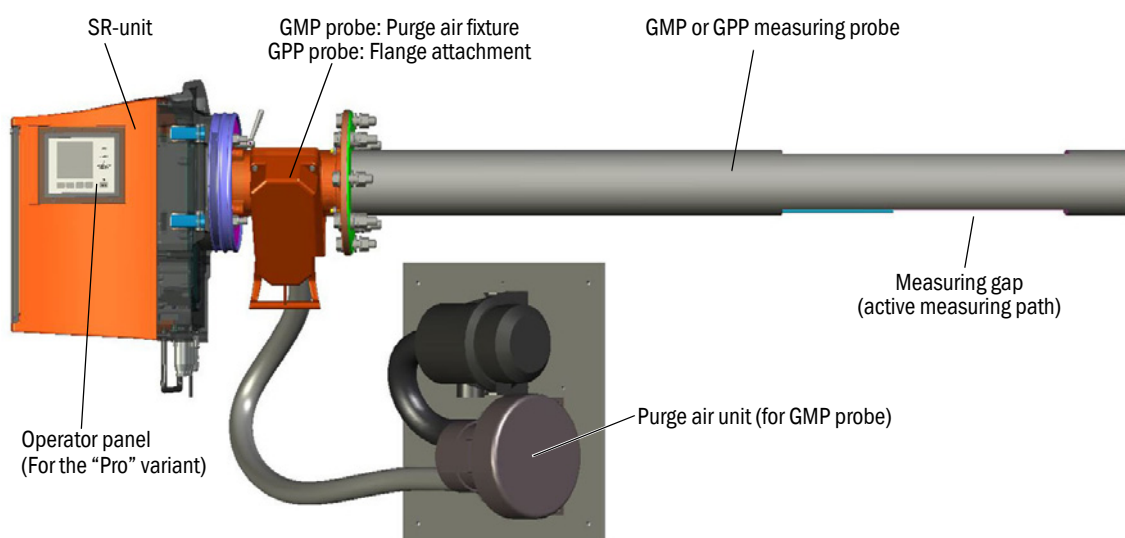

2.5.1 Measuring probe

Probe types:

- Measuring probe with open measuring gap (GMP probe).
GMP probes require a purge air supply to protect the window against contamination.
- Gas diffusion probe (GPP probe) with gas permeable ceramic filter.
GPP probes are fitted with an automatically controlled heater to prevent condensate on the windows.

Both probe versions have an integrated temperature and pressure sensor.

2.6 Purge air unit (for GMP measuring probe)

The purge air unit supplies filtered ambient air to the purge air fixtures and protects the windows of the SR-unit from contamination and high gas temperatures.

The purge air is blown into the gas duct through the flange with tube.



Further information on the purge air unit → Operating Instructions of the purge air unit.

2.6.1 Light sources

GM32	GM32 LowNOx version
Deuterium lamp (UV lamp)	Deuterium lamp (UV lamp)
	Blue light source (LED)

Table 1: Light sources



CAUTION: Eye injuries caused by improper handling of UV or blue light beams
The UV beam of the deuterium lamp or the blue light beam of the LED can cause serious injuries through direct eye and skin contact. This results in the following safety measures when working on the switched on device with access to the light beam exit:

- ▶ Always wear UV protective goggles (in accordance with standard EN 170)
- ▶ The UV goggles do not provide protection against injuries caused by blue light beams, therefore switch the LED off when working.
- ▶ Use the lamps only when they are perfectly safe. Operation is not allowed when the lamp, supply lines or operating parts are visibly damaged.

Fig. 3: GM32 light beam exit

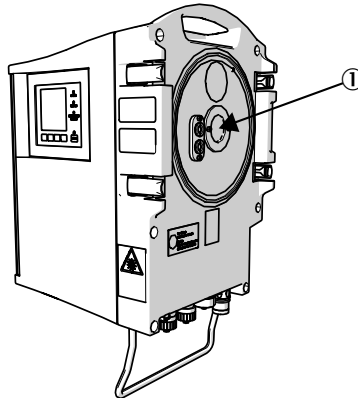

① Light beam exit

3 Preparing the gas duct side

3.1 Preparing the sampling point



WARNING: Risk of explosion in potentially explosive atmospheres

! Do not use the GM32 in potentially explosive atmospheres.



- The basis for determining the sampling point is the preceding project planning, the information in the final inspection record of the GM32 and the regulations of the local authorities.

The operator is responsible for:

- Determining the sampling point (e.g., determining a representative sampling point).
- Preparing the sampling point (e.g., load carrying capacity of the welded flange).

- ▶ Determine the installation location.
Observe the ambient conditions of the GM32, see [“System GM32 Standard”](#), page 65 and [“System GM32 TRS-PE”](#), page 66.
- ▶ Observe the space requirements for the SR-unit, see [“Dimensions”](#), page 74.
Provide for additional space for maintenance work, swiveling the housing door open, pulling the measuring probe out.
- ▶ Determine the installation location for the connection unit.
Observe maximum line lengths, see [“Electrical connection diagram”](#), page 19, or as planned.
- ▶ Provide the power supply for the connection unit and, when necessary, for the GPP probe.
Observe the power requirements, see [“Gas-testable measuring probe \(GPP\)”](#), page 67.
- ▶ Lay the signal lines.
- ▶ For GMP probe: Determine the installation location for the purge air unit, see [“Electrical connection diagram”](#), page 19, or as planned.
Provide clearance for changing the filter element, → Technical data of purge air unit.

3.1.1 Checking the scope of delivery



- ▶ Compare the data of the final inspection record with the data of the order confirmation - they must be identical.

- ▶ Check the scope of delivery according to the order confirmation/delivery note.

3.2 Overview of the installation steps (duct-side work)

Special tools / auxiliary materials	Part number	Required for
Adjustment device	2034121	Alignment of "flanges with tube"
Jaw wrench 19 mm 24 mm	---	Flange screw fitting
Screwdriver for 0.6 x 3.5 mm 1.0 x 5.5 mm	---	Connections
Allen key 3 mm 4 mm 5 mm	---	Connections
Personal protective equipment	---	Protection when working on the stack

Table 2: Special tools /auxiliary materials for installation

Fig. 4: Example: Installation option

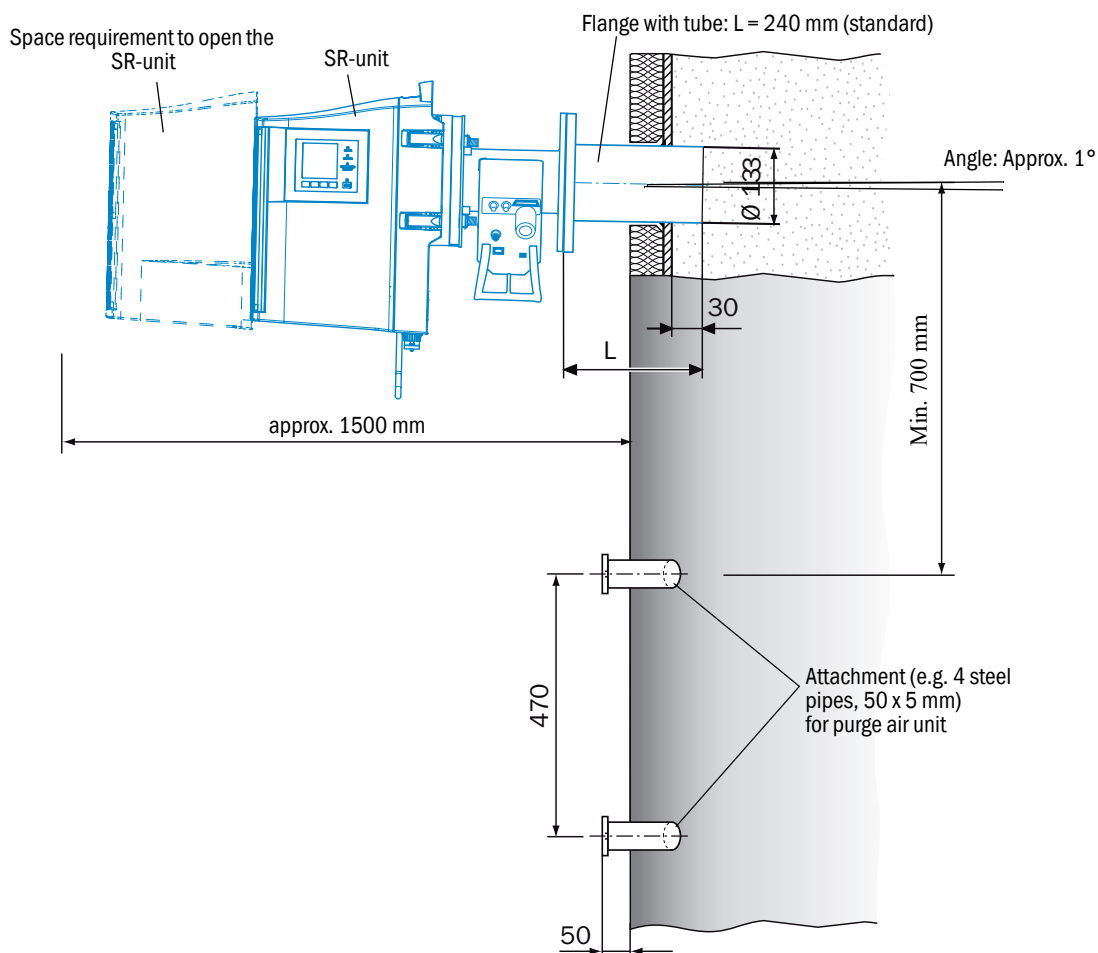

3.2.1 Work steps (overview)

Step	Procedure	Reference
1	Installing the flange with tube	see "Installing the flange with tube on the gas duct", page 17
2	Installing the connection unit	see "Installing the connection unit", page 18
3	GMP probe: Installing the purge air unit	see "Installing the purge air unit (for GMP probe)", page 18

3.2.2 Installing the flange with tube on the gas duct



WARNING: Hazard through gas escaping out of the gas duct

Hot and/or noxious gases can escape during work on the gas duct, depending on the plant condition.

- ▶ Work on the gas duct may only be performed by skilled persons who, based on their technical training and knowledge as well as knowledge of the relevant regulations, can assess the tasks given and recognize the hazards involved.

- 1 Cut openings on the gas duct for the flange with tube.
- 2 Insert the flange with tube so that the marking (TOP) ▲ upwards vertically (irrespective of the gas duct angle) and attach the flange with tube.
 - The tube must project at least 30 mm into the gas duct.
 - Make sure the probe does not collide with other devices or fittings.
 - Tilt the tube slightly downwards (approx. 1 °).
This allows any condensate to drain off.
- 3 Now fix the flange with tube properly to the gas duct.
Make sure that the alignment of the flange does not change.
- 4 If necessary, attach duct insulation, protect GM32 from heat.



NOTE: Observe the ambient temperature of the GM32

- ▶ When the gas duct is hot, insulate the duct and flanges so that the GM32 is protected from high temperatures, see "System: GM32", page 65.

3.3 Installing the connection unit

Fig. 5: Connection unit

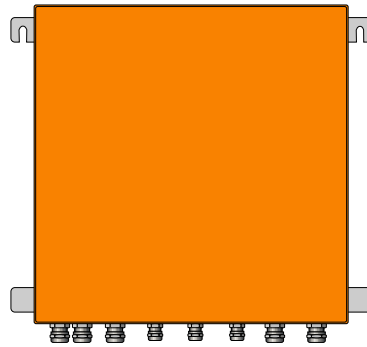

- Line lengths to the GM32 sender/receiver unit according to project planning.
- ▶ Provide threaded bolts (4) to screw on the connection unit and screw on the connection unit, see [“Connection unit \(all dimensions in mm\)”](#), page 77.
- !▶ Do not make the electrical connection to the connection unit yet.

3.4 Installing the purge air unit (for GMP probe)

- Length of the purge air hose to the GM32 according to project planning



Installing the purge air unit → Operating Instructions of purge air unit.



NOTE: Adequate purge air pressure

- ▶ Make sure the purge air supply is sufficiently dimensioned to press the purge air into the gas duct.
If required, please contact Endress+Hauser Customer Service or your local representative.

3.5 Laying the electrical connection lines

Fig. 6: Electrical connection diagram

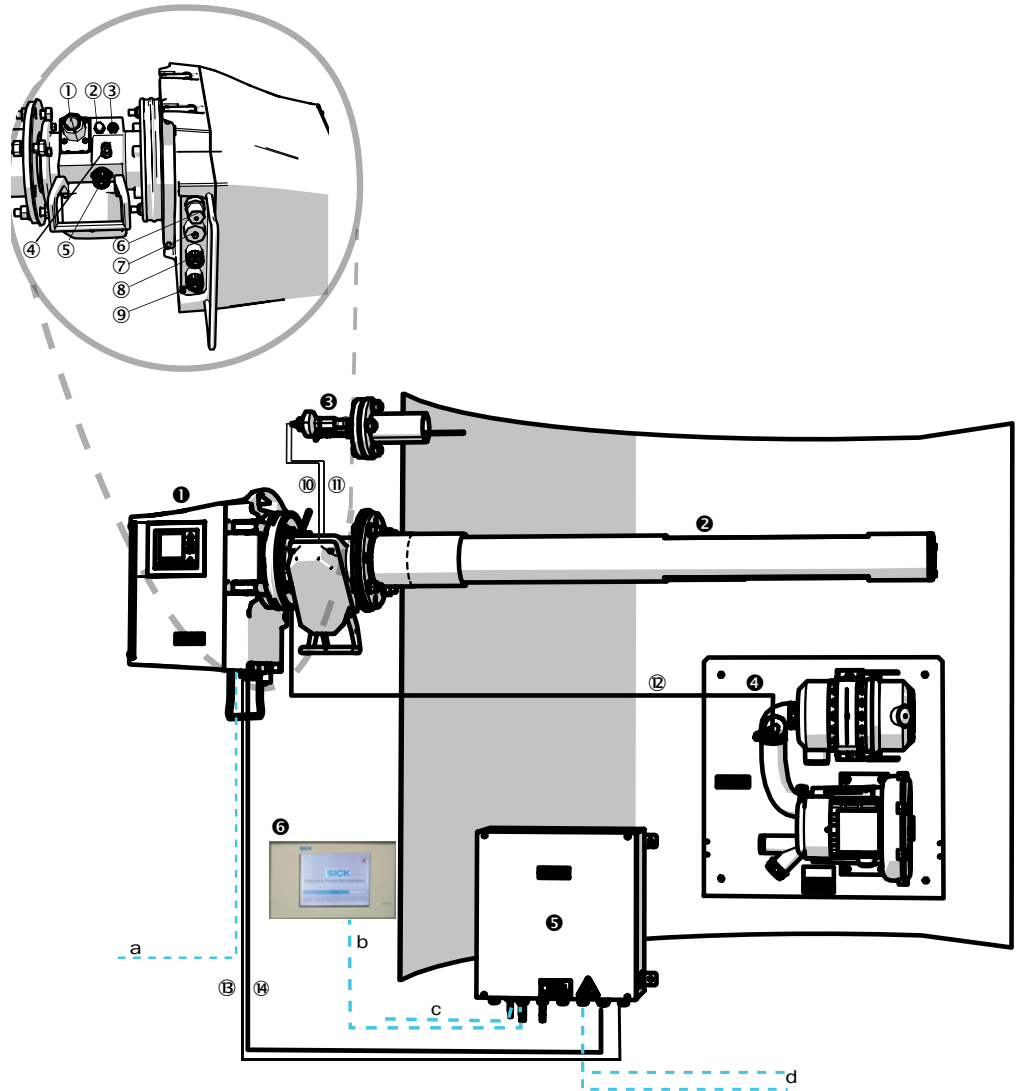

1	Sender/receiver unit (SR)	
2	Measuring probe (GMP or GPP)	Measuring probe pre-assembled with purge air fixture
3	Pressure and temperature sensor	Optional for probe
4	Purge air unit SLV4	Wiring and technical data, see Data Sheet SLV4
5	Connection unit (AU)	
6	SCU (option)	

Table 3: Hardware connection diagram

Connections of sender/receiver unit and purge air fixture (see detailed view)	
1	Purge air supply connection
2	Temperature sensor connection
3	Purge air/filter monitor connection

Table 4: Signal cable

Connections of sender/receiver unit and purge air fixture (see detailed view)	
④	Test gas connection (GPP)
⑤	CAN line connection: Purge air fixture - SR-unit (see ⑨)
⑥	Ethernet PC/network connection
⑦	Power supply connection
⑧	CAN line connection: (see ⑬)
⑨	Purge air fixture connection

Table 4: Signal cable

	Signal line for connection	Length	Part number	Remark
⑩	Purge air fixture - pressure sensor			
⑪	Purge air fixture - temperature sensor			
⑫	Filter monitor	5 m	2032143	Included in the purge air fixture
⑬	Power supply SR (standard)	<ul style="list-style-type: none"> • 10 m • 20 m 	<ul style="list-style-type: none"> • 2046548 • 2046549 	
⑭	CAN line connection unit - sender/receiver unit	<ul style="list-style-type: none"> • 10 m • 20 m 	<ul style="list-style-type: none"> • 2028786 • 2045422 	Order separately
On-site lines				
a	Ethernet – PC/network line			
b	SCU connection			On-site Configuration and connections see “Operating Instructions SCU”
c	Power supply 100 ... 240 V AC, 50/60 Hz			On-site
d	On-site terminal connections (inputs/outputs)			Technical Information “Modular System I/O”

Table 5: Signal lines

3.5.1 General information



CAUTION: Hazard caused by electric voltages

- ▶ Only let the work described in the following be carried out by skilled electricians familiar with potential hazards.



NOTE:

- Before signal connections are established (also with plug connections):
- ▶ Disconnect the GM32 and any connected devices from the voltage supply. Otherwise the internal electronics can be damaged.

3.5.2 Connecting I/O interfaces (option)



- ▶ Do not lay power supply cables immediately next to signal cables.

- ▶ Route the data lines through the M screw fittings.
- ▶ Connect the data line.



- ▶ Description of I/O modules
→ Operating Instructions "Modular I/O System".

Fig. 7: Connection unit (inside): Location of I/O modules

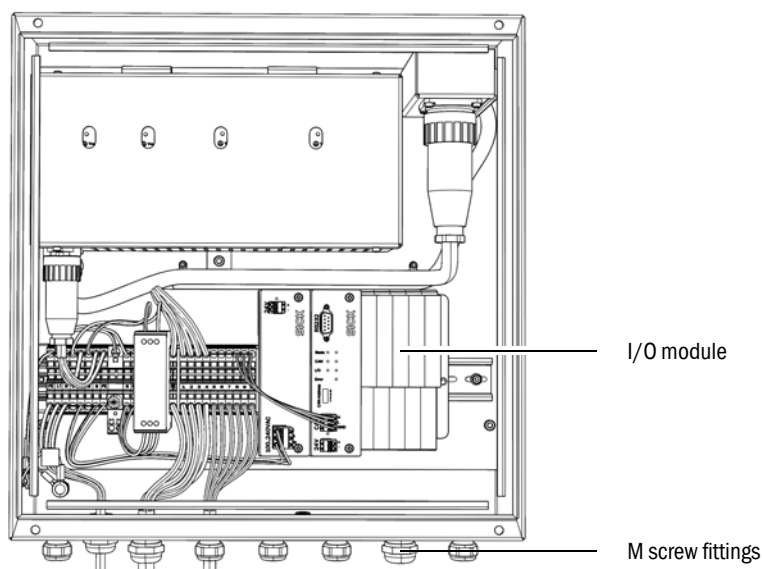

3.5.2.1 Default values for interfaces

Fig. 8: Example: I/O module pin assignment

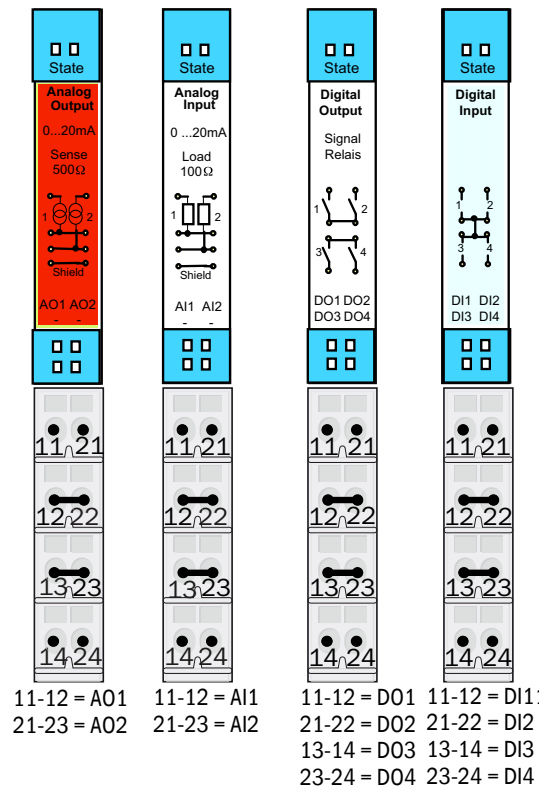

Analog input	Pin assignment	Function
AI 1	11, 12	Temperature (internally wired)
AI 2	21, 23	Pressure (internally wired)
AI 3	11, 12	Humidity



The analog input assignment shown in the Table is a default setting. The assignment of the inputs can be freely configured with SOPAS. For more information, see the SOPAS ET Operating Instructions.

The following Table shows the typical factory settings for the digital and analog inputs and outputs.

Analog output	Pin assignment	Function
AO 1	11, 12	User-specific
AO 2	21, 23	User-specific

Digital input	Pin assignment	Function
DI 1	11, 12	Check_cycle
DI 2	21, 22	Maintenance
DI 3	13, 14	Output_control_values
DI 4	23, 24	Disable_check_cycle
DI 5	11, 12 ^[1]	Purge_air_status
DI 6	21, 22 ^[1]	---
DI 7	13, 14 ^[1]	---
DI 8	23, 24 ^[1]	---

[1] On second module

Digital output	Pin assignment	Function
DO 1	11, 12	Failure (inverted)
DO 2	21, 22	Maintenance_Request
DO 3	13, 14	Not_measuring
DO 4	23, 24	Output_control_values
DO 5	11, 12 ^[1]	Uncertain
DO 6	21, 22 ^[1]	Extended
DO 7	13, 14 ^[1]	Purge_air_failure
DO 8	23, 24 ^[1]	No_function
Configurable	Configurable	Measuring range switch-over → Technical Information GM32

[1] On second module



Information concerning the customer-specific module assignment

- The module layout from the left to the right always has this sequence: AO-AI-DO-DI
- The number of inputs and outputs is predetermined:
 - 2 x AO
 - 2 x AI
 - 4 x DO
 - 4 x DI
- Second measuring range: AO is always on the right next to the respective component.

3.5.3 Laying the electrical connection lines to the SR-unit



Electrical connections on GM32, see "Laying the electrical connection lines", page 19

- 1 Lay the electrical connection lines from the connection unit to the SR-unit.
- 2 For GMP probe: Signal line from the purge air unit (connection on the purge air unit → Operating Instructions of the purge air unit) to the purge air fixture.

3.5.4 Preparing the power supply



Take precautions to prevent switching off the purge air supply accidentally.
 ▶ Attach a clearly visible warning against accidentally switching off the separation equipment for the purge air unit.

- 1 Requirements to connecting cable:
 - Cross-section: 3 x 1.5 mm²
 - Temperature class: -40 ... +85 °C
- 2 Provide a separate external disconnecting device for:
 - Connection unit (max. power input, see “System: GM32”, page 65).
 - For GMP probe: Purge air unit (→ Technical data of the purge air unit)
 - For GPP probe: Heater (max. power input, see “Gas-testable measuring probe (GPP)”, page 67).
 - Mark the disconnecting device as disconnecting device for the GM32.
- 3 Lay the electric lines of the power supply to the connection unit and connect the power supply in the connection unit.
 Always connect a protective conductor to PE.

Fig. 9: Power connection in the connection unit

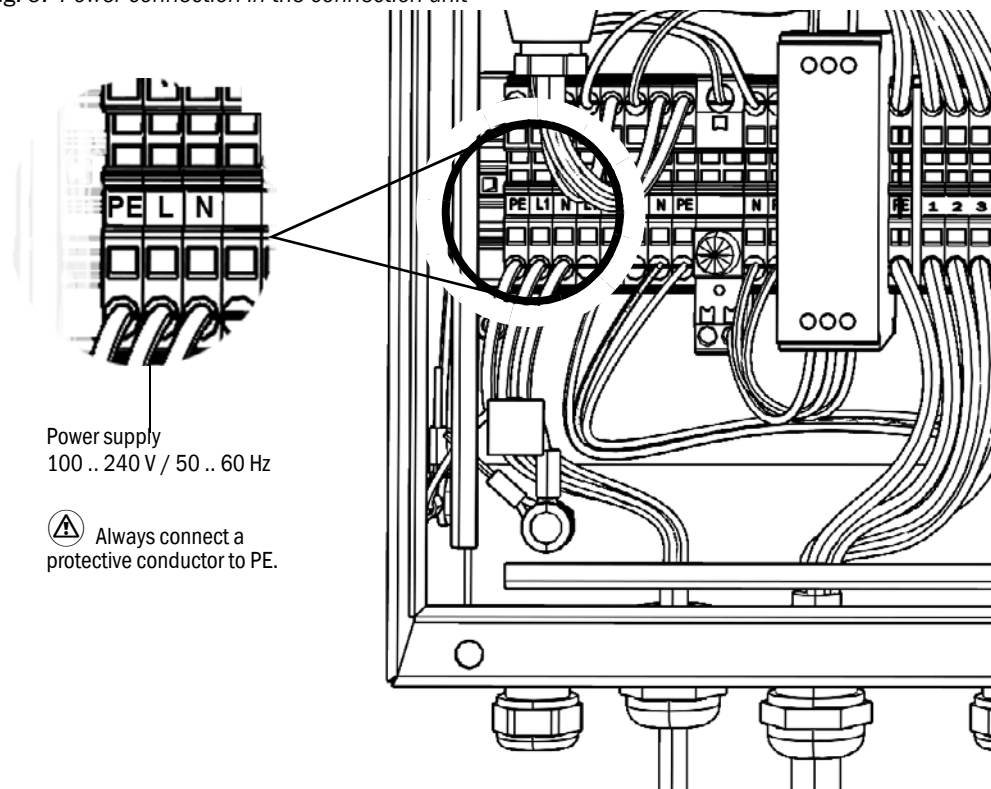

The power supply must remain switched off until the GM32 is to be put into operation.

- 4 For GMP probe: Lay the electric lines to the purge air unit.
 For GPP probe: Lay the electric lines for the probe heater.

4 Start-up

4.1 Necessary technical knowledge for start-up



See also:

- Start-up Checklist
- Menu driven start-up (SOPAS ET)



The following requirements must be met for the start-up:

- You are basically familiar with GM32.
- You are familiar with the local situation, especially the potential hazards caused by gases in the gas duct (hot/noxious). You are capable of recognizing and preventing danger by possibly escaping gases.
- The specifications are met in accordance with the project planning.(→ Final inspection record).
- The assembly location has been prepared accordingly, see [“Preparing the gas duct side”, page 15](#).

If one of these requirements is not met:

- ▶ Please contact Endress+Hauser Customer Service or your local representative.

Gases



WARNING: Hazard resulting from gases in the gas duct

Hot and/or noxious gases can escape during work on the gas duct, depending on the plant condition.

- ▶ Work on the gas duct may only be performed by skilled persons who, based on their technical training and knowledge as well as knowledge of the relevant regulations, can assess the tasks given and recognize the hazards involved.



WARNING: Risk to health through contact with toxic gases

The modules and equipment contain enclosed, potentially dangerous gases that can escape should a defect or leak occur.

NO:

Max. total volume: 2 ml

Max. concentration inside the device with a leak (defect): 40 ppm

If a leak occurs, the concentrations inside the enclosed device can increase up to a certain concentration. These concentrations are also shown in the Table.

- ▶ Regularly check the state of the device/module seals.
- ▶ Only open the equipment when good ventilation is available, especially when a leak of one of the equipment components is suspected.

Electrical safety

WARNING: Endangerment of electrical safety during installation and maintenance work when the power supply is not switched off

An electrical accident can occur during installation and maintenance work when the power supply to the device or lines is not switched off using a power isolating switch/circuit breaker.

- ▶ Before starting the work on the device, ensure the power supply can be switched off using a power isolating switch/circuit breaker in accordance with DIN EN 61010.
 - ▶ Make sure the power isolating switch is easily accessible.
 - ▶ An additional separation device is mandatory when the power isolating switch cannot be accessed or only with difficulty after installation of the device connection.
 - ▶ After completion of the work or for test purposes, the power supply may only be activated again by authorized personnel complying with the safety regulations.
-

WARNING: Endangerment of electrical safety through power cable with incorrect rating

Electrical accidents can occur when the specifications of a replacement for a removable power line have not been adequately observed.

- ▶ Always observe the exact specifications in the Operating Instructions (Technical Data Section) when replacing a removable power cable.
-

WARNING: Hazard by voltage

- ▶ All connectors of the power supply to the involved subassemblies or lines must be disconnected before the installation work.
-

Grounding

CAUTION: Device damage through incorrect or non-existing grounding

During installation and maintenance work, it must be ensured that the protective grounding to the devices and/or lines involved is effective in accordance with EN 61010-1.

UV and blue light beams

CAUTION: Eye injuries caused by improper handling of UV or blue light beams

The UV beam of the deuterium lamp or the blue light beam of the LED can cause serious injuries through direct eye and skin contact. This results in the following safety measures when working on the switched on device with access to the light beam exit:

- ▶ Always wear UV protective goggles (in accordance with standard EN 170).
 - ▶ The UV goggles do not provide protection against injuries caused by blue light beams, therefore switch the LED off when working.
 - ▶ Use the lamps only when they are perfectly safe. Operation is not allowed when the lamp, supply lines or operating parts are visibly damaged.
-

Use in explosive atmosphere

WARNING: Risk of explosion in potentially explosive atmospheres

- ▶ Do not use the GM32 in potentially explosive atmospheres.
-

Preventing overpressure in the equipment



WARNING: Hazard through overpressure in cavities!

With GPP probes, overpressure can arise in the reflector compartment or in the gas lines, e.g., through deposits of penetrating liquid, when the probe comes into contact with the hot sample gas. Open connections carefully, make visual and continuity checks.

- ▶ Make regular visual and continuity checks of the cavities.
- ▶ At the same time, take all precautionary measures described in the Operating Instructions when opening the connections.

Purge air unit SLV4



WARNING: Risk of fire through hot gas escaping in installations with overpressure conditions

On installations with overpressure, the purge air hose can be severely damaged by escaping hot gas and can catch fire depending on the temperature.

On installations with overpressure as well as gas temperatures over 200 °C:

- ▶ Ensure reverse flow is prevented by fitting a (trip) flap or a valve.
- ▶ Regularly check the functionality of the reverse flow safeguard.

4.2 Required material (not included in the scope of delivery)

Material required	Part number	Required for
Optical adjustment device	2034121	Aligning the purge air fixtures
Optical cleaning cloth	4003353	Cleaning the windows
19 mm jaw wrench	---	Aligning the flanges
Personal protective equipment	---	Protection when working on the stack

Table 6: Material required for start-up

4.3 Overview of assembly steps

Procedure	Reference
Removing the transport safety devices	see “Transport safety devices”, page 29
Installing the device flange on the purge air fixture	see “Installing the device flange on the purge air fixture”, page 30
Aligning the measuring probe	see “Aligning the measuring probe in flow direction”, page 31
For GPP probe: Electrical connection of heater	see “For the GPP probe: Electrical connection”, page 32
Electrical connection of the SR-unit	see “Electrical connection of the SR-unit”, page 33
Switching on the power supply	see “Switching on the power supply of the GM32”, page 33
For GMP probe: Start-up of the purge air supply	see “For GMP probe: Start-up of the purge air supply”, page 33
Installing the measuring probe in the gas duct	see “Installing the measuring probe in the gas duct”, page 34
Installing the SR-unit on the device flange	see “Installing the SR-unit on the device flange”, page 36
Optical fine alignment of the SR-unit	see “Optical fine alignment of the SR-unit”, page 36
Installing weatherproof covers (option)	see “Installing weatherproof covers (option)”, page 39

Table 7: Installation steps overview

4.4 Transport safety devices

- 1 Remove the transport safety device of the SR-unit.

Fig. 10: Transport safety devices

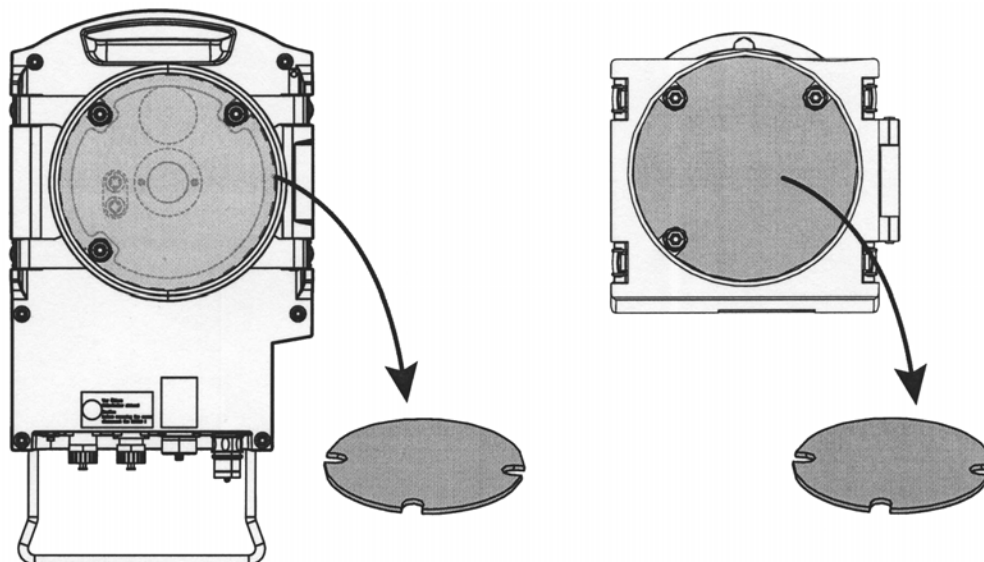

- 2 Remove the probe transport safety device.
The probe transport safety devices depend on the type of probe.
 - a) Remove the protective stickers.
 - b) Take out the plugs.

Fig. 11: Probe transport safety devices (shown here on a GPP probe)

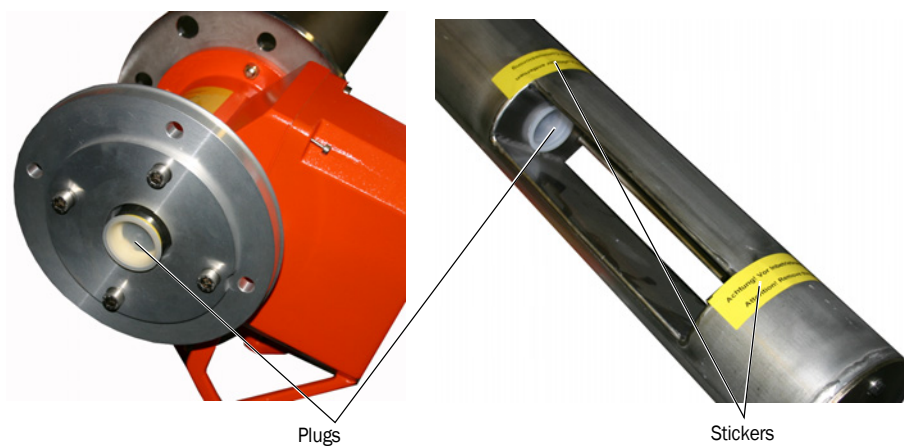

- 3 Store the transport safety devices.

4.5 Installing the device flange on the purge air fixture

Remark on the GPP probe: The procedure for the GPP probe flange fixture corresponds to the procedure shown here for the purge air fixture.

- 1 *Recommendation:* For easier handling during installation:
Remove the SR-unit from the device flange before installation, see [“Swiveling out and removing the SR-unit”](#), page 49.
- 2 Installation on the SR-unit side:

Fig. 12: Installing the device flange on the purge air fixture

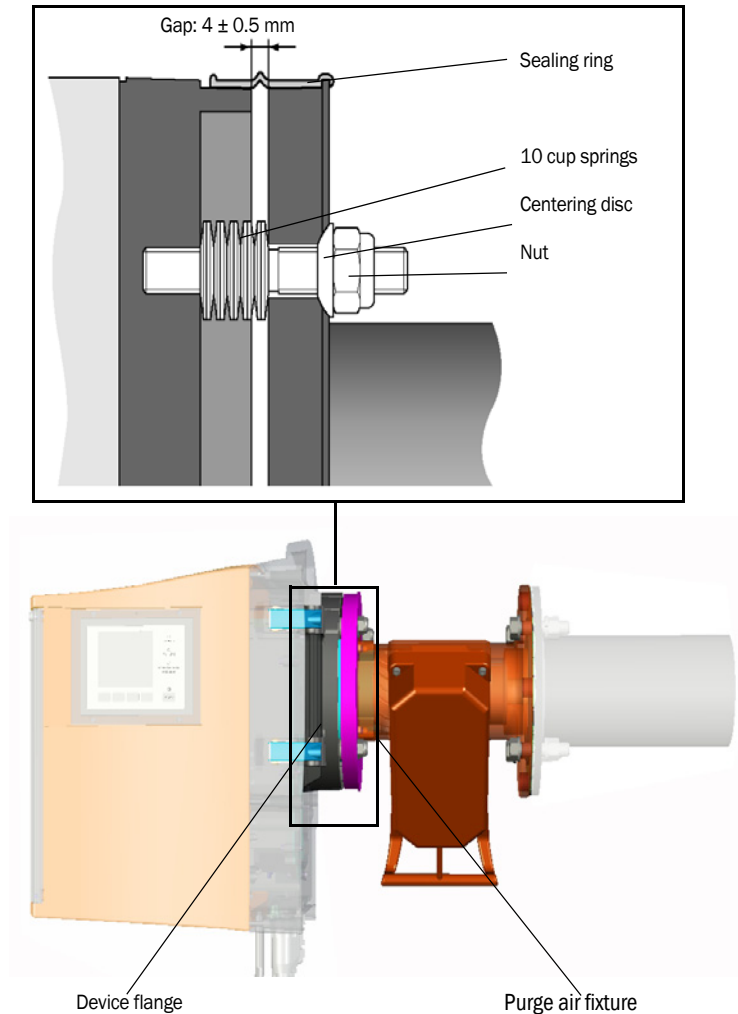

- a) Put 10 cup springs each, back-to-back, onto the three threaded bolts on the device flange.
- b) Pull the sealing ring over the flange of the purge air fixture and hang it loosely over the purge air unit.
- c) Push the device flange onto the purge air fixture.
- d) Position the centering discs.
Notice: Observe the direction of the centering disc: The convex side must fit into the groove on the purge air fixture.
- e) Tighten the self-locking nuts with a jaw wrench (19 mm) so that the cup springs are slightly compressed and an even gap of approx. 4 mm remains.
- f) Fit the sealing ring above the gap, see Fig. 12.

4.6 Aligning the measuring probe in flow direction

The fitting angle of the probe is already set before delivery when the gas flow direction has been defined during project planning for the GM32.

A sticker marks the setting.

Fig. 13: Flow direction marking and setting

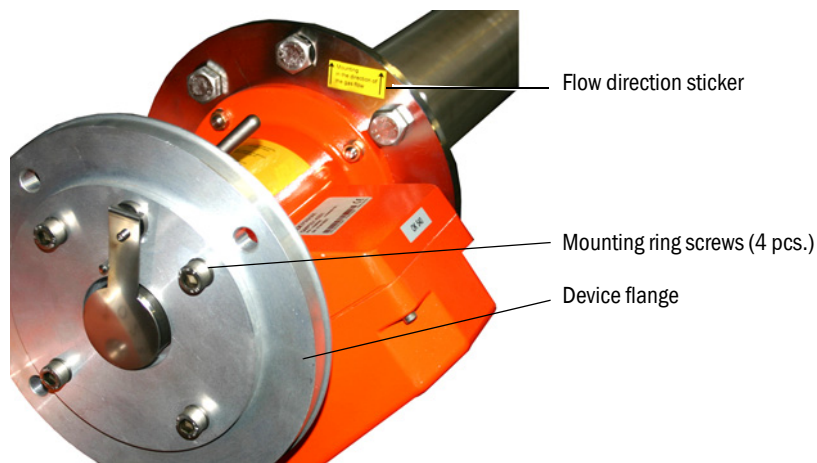

4.6.1 When the probe alignment has to be set

- The measuring gap must be aligned in sample gas flow direction.
- The SR-unit must be fitted vertically.

Rotate the device flange to align the probe.

To change the measuring probe alignment:

- 1 Loosen the 4 screws on the mounting ring, (see Fig. 13).
- 2 Rotate the device flange:
 - The measuring gap must point in flow direction.
 - The device flange must be positioned so that the SR-unit can be fitted in a vertical position.
- 3 Tighten the screws on the mounting ring again to fasten the device flange in this position.

4.7 For the GPP probe: Electrical connection

- 1 Unscrew and take off the purge air fixture cover.
- 2 Check the switch setting for swapping the voltage to the available power voltage and correct when necessary.

Fig. 14: Switch to select voltage and fuses

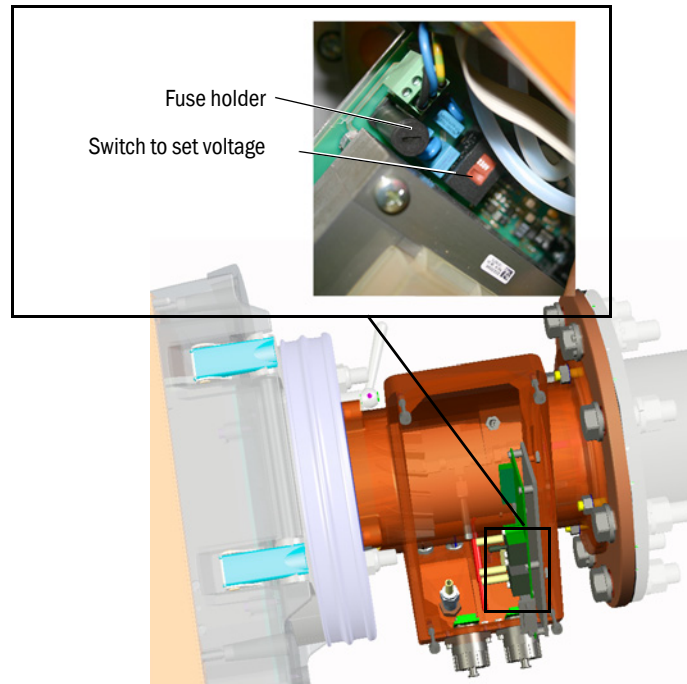

- 3 Check the fuses according to the available power voltage and replace when necessary.



NOTE: The fuses depend on the available power voltage.

- ▶ Only use the correct fuses.
 - 230 V: 1.6 A (slow)
 - 115 V: 2.5 A (slow)

- 4 Connect the power supply to the power voltage.

Line with three wires:

- Green-yellow: PE A protective conductor must be connected.
- Blue: N
- Brown: L1



NOTE: Danger of condensation

The GPP probe must have reached its operating temperature before being inserted in the gas duct.

- ▶ First fit the GPP probe during final installation in the gas duct, see [“Installing the measuring probe in the gas duct”, page 34.](#)
- ▶ Attach clearly visible warnings against accidental switching-off to all switching devices where the GPP probe heater can be switched off.

4.8 Electrical connection of the SR-unit



Connection diagram, see “Laying the electrical connection lines”, page 19.

- 1 Connect the electric lines from the connection unit to the SR-unit.
- 2 For GMP probe: Connect the electric line from the purge air unit to the purge air fixture (terminal: *SLV filter*).
- 3 Screw the grounding conductor (2.5 mm²) of the equipment ground tight to the screw terminal, see Fig. 15.

Fig. 15: Connection of the grounding conductor at the bottom of the SR-unit

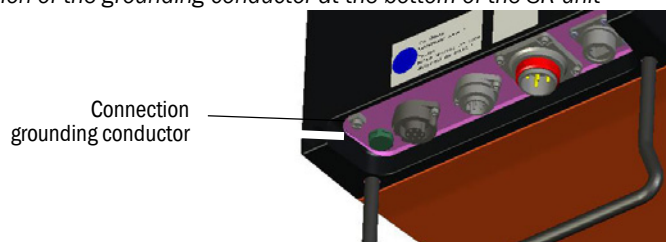

4.9 Switching on the power supply of the GM32

- 1 Switch on the power supply on the fuse, fitted by the operator, of the connection unit.
- 2 An initialization screen is shown on the operator panel of the sender/receiver unit (for the “Pro” variant).
- 3 Measured values are then shown.
Ignore the displays until the start-up of the GM32 is complete.

4.10 For GMP probe: Start-up of the purge air supply

Fig. 16: Connection of the purge air supply



- 1 Switch on the power supply of the purge air unit on the fuse (fitted by the operator) of the purge air unit.
 - Check the function: A strong air flow must be noticeable.
If it is not noticeable: → Operating Instructions of purge air unit.
 - Blow out any dust that may have entered the purge air hose.
- 2 Check the switch function of the pressure controller in the purge air unit, e.g. by partly closing off the suction opening of the purge air unit.
The “Purge air signal” warning must be shown.
- 3 Switch the power supply off again.
- 4 Connect the purge air hose to the purge air connection with a hose clamp, see Fig. 16. If necessary, remove the protective cap from the purge air connections.

- 5 Switch the power supply of the purge air unit on again.



The purge air supply protects the measuring system from contamination and overheating.

- ▶ Ensure that the purge air pressure is adequate to push the purge air into the gas duct.

The purge air supply may not be switched off while the gas analyzer is on the gas duct.

- ▶ Attach clearly visible warnings against accidental switching-off to all switching devices where the purge air supply can be switched off.
-

4.11 Installing the measuring probe in the gas duct



NOTE: Hazard of dropping down

SR-unit and probe are heavy.

- ▶ Install the SR-unit and the probe separately.
-



NOTE: With the GPP probe: Danger of condensation

The GPP probe must have reached its operating temperature before the measuring probe is inserted in the gas duct.

- ▶ Wait until the probe has reached its operating temperature before inserting the probe.

Do not switch the GPP probe heater off as long as the GPP probe measuring system is in the gas duct.

- ▶ Attach clearly visible warnings against accidental switching-off to all switching devices where the GPP probe heater could be switched off.
-

- 1 Insert the measuring probe with purge air fixture or flange attachment (without SR-unit) in the flange with tube on the duct side.
 - For GMP measuring probe: Do not interrupt the purge air feed.
 - For GPP measuring probe: Do not interrupt the power supply to the measuring probe.
- 2 Screw the measuring probe with purge air fixture or flange attachment tight to the flange with tube (seal with 4 screws).

Fig. 17: Purge air fixture installed on the flange with tube

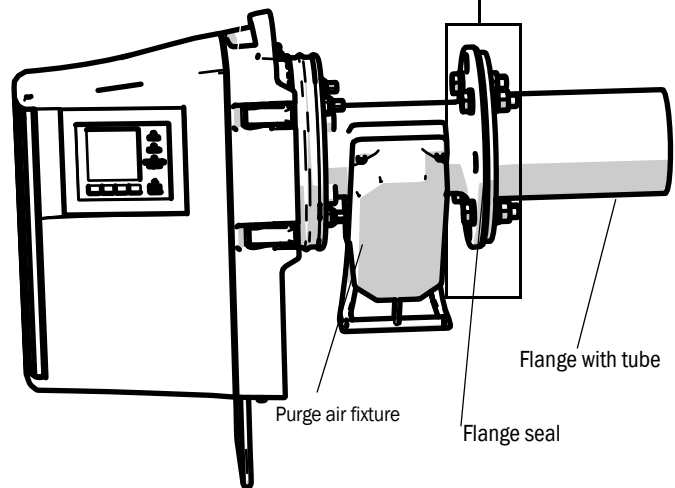
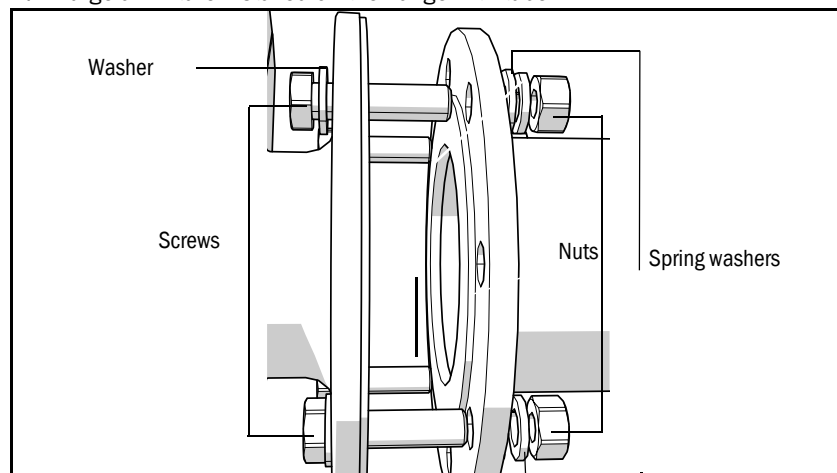

Fig. 18: Purge air fixture installed on the flange with tube

4.12 Installing the SR-unit on the device flange



NOTE: Hazard of dropping down

SR-unit and probe are heavy.

- ▶ Always install the SR-unit and the probe separately.

1 Install the SR-unit:

- a) Fit the SR-unit on the device flange into the hinge (swiveling-out direction preferably to the “left”).
- b) Insert the hinge pin from above.



NOTE: If the hinge pin has not been correctly inserted, the SR-unit can drop when swiveled out.

- ▶ Ensure the hinge pin is fully inserted.

Fig. 19: Install the SR-unit:

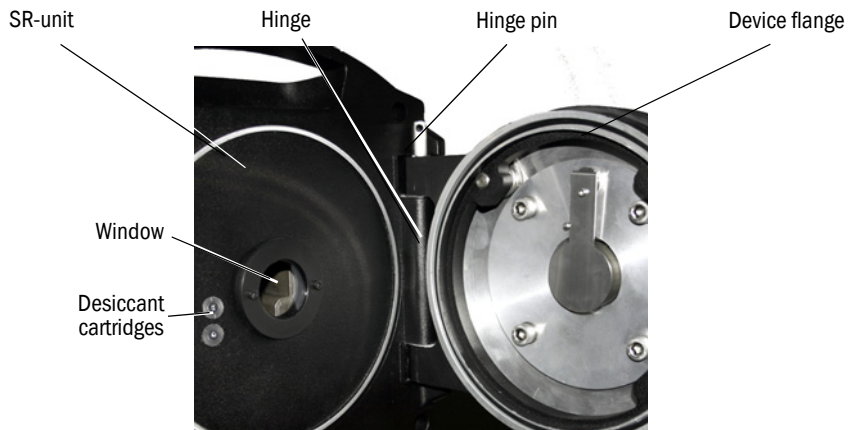

- c) Check the window for cleanness and clean, if required, see [“Cleaning the window”](#), page 50.
- d) Check the desiccant cartridge is dry, see [“Checking and replacing the desiccant cartridges”](#), page 50.
- e) Close the SR-unit with the 4 quick-release fasteners.
- f) For GMP probe: Set the lever on the purge air fixture to the “open” position.

Fig. 20: Lever of the locking device (for GMP probe)

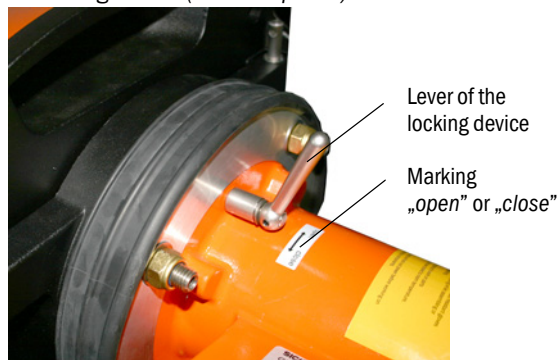

4.13 Optical fine alignment of the SR-unit

Optical alignment of the SR-unit:

- ▶ With SOPAS ET: → Leave this work to a skilled person familiar with SOPAS ET.
- ▶ With operating unit: see [page 45](#)

4.14 OPC



- ▶ Make sure that the current OPC server software has been installed.
- ▶ Observe the license conditions included with the delivered documentation.

- *OPC* (Openness, Productivity, Collaboration) is a standardized software interface which supports exchanging data between applications from different manufacturers.
- The SOPAS OPC server uses DCOM technology (Distributed Component Object Model) for communication between applications.
This allows the SOPAS OPC server to exchange data with a local process or also with a remote computer connected via Ethernet (TCP/IP).
- The OPC server collects the data from the GM32 and makes the data available as an OPC object.
- The OPC client accesses the data made available by the OPC server and then processes the data.

Fig. 21: OPC communication paths (example)

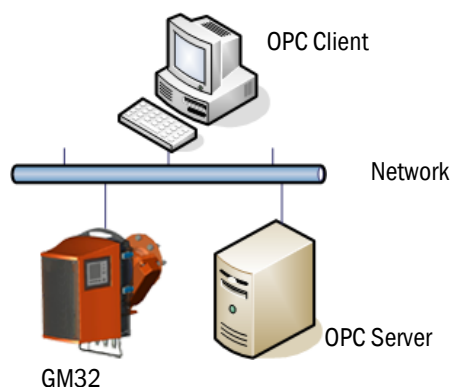

Installing the OPC server and "first steps":
 → Operating Instructions SCU
 → Online help of the OPC server

4.14.1 OPC interface

The following data are available on the OPC interface:

Folder	Folder	Element	Data type	Significance
Device	Status	Location	String	Installation location parameter entry. Can be set in SOPAS ET under: Parameter - Device parameters
		Failure	Bool	Device error
		Maintenance request		Maintenance request
		Not Measuring		Device not in measuring operation. Set when either maintenance, alignment mode, check cycle, zero adjust or filter box measurement active
		Check		Set when check cycle active
		Uncertain		A measured value has uncertain status
		Extended		A measured value has extended status
Measured Values	Measured Value 1	Activated	Bool	Measured value available
		Name	String	Measured value identifier maximum 32 characters
		Dimension		Physical unit maximum 32 characters
		Value	Real	Measured value
		CCycle Zero Value		Zero point check value
		CCycle Span Value		Span check value (70%)
		Failure	Bool	Measured value status error
		Maintenance request		Measured value status maintenance request
		Uncertain		Measured value status uncertain Marginal conditions for measurement (e.g. pressure, temperature) have exceeded the allowable limit value
		Extended		Measured value status extended Marginal conditions for measurement (e.g. pressure, temperature) are close to the allowable limit value
		Measured Value 2-16	Corresponds to Measured Value 1	
Diagnosis	Lamp	Performance	Real	Lamp quality value
	LED	Performance	Real	LED quality value
Start CCycle	CCycle Signal		Bool	Signal for check cycle execution
Start Maintenance	Maintenance Signal		Bool	Signal for maintenance mode
Disable CCycle	Disable CCycle Signal		Bool	Signal to prevent check cycle execution

Table 8: Table of data available via the OPC interface

4.15 Installing weatherproof covers (option)

Fig. 22: Weatherproof cover of sender/receiver unit

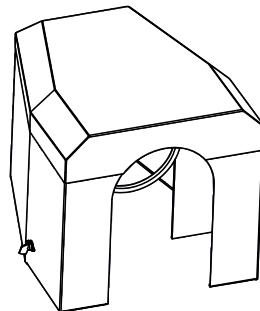

2 steps are necessary to fit the weatherproof cover:

- 1 Install the installation plate on the flange of the purge air fixture.

Fig. 23: Weatherproof cover

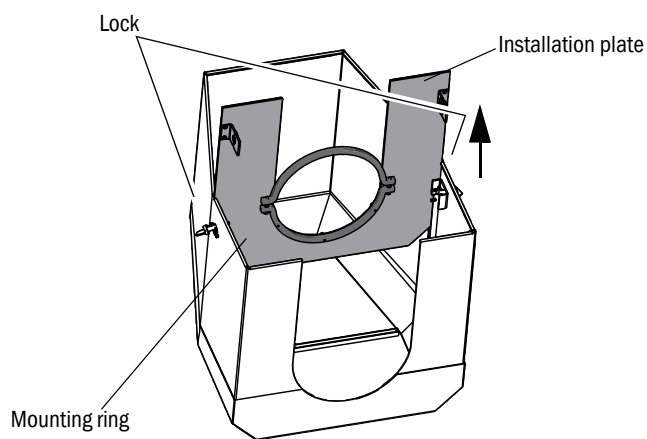

- ▶ Lay the weatherproof cover upside down on the floor.
- ▶ Open and unhinge the locks on both sides.
- ▶ Pull the installation plate upwards and remove it from the cover.

Fig. 24: Fitting the cover on the purge air fixture

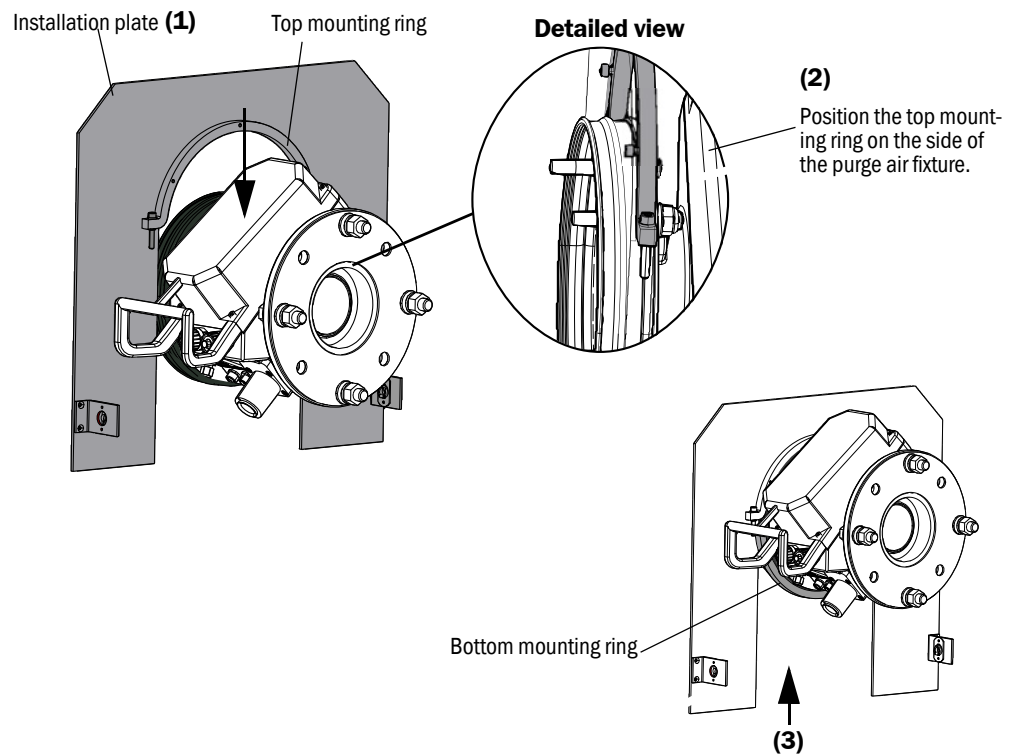

- ▶ Remove the bottom mounting ring.
- ▶ Place installation plate **(1)** onto the rubber band of the purge air fixture from the top. Position the mounting ring on the side of the purge air fixture **(2)**.
- ▶ Fasten bottom mounting ring **(3)** again.

2 Fit the cover

Fig. 25: Fitted weatherproof cover

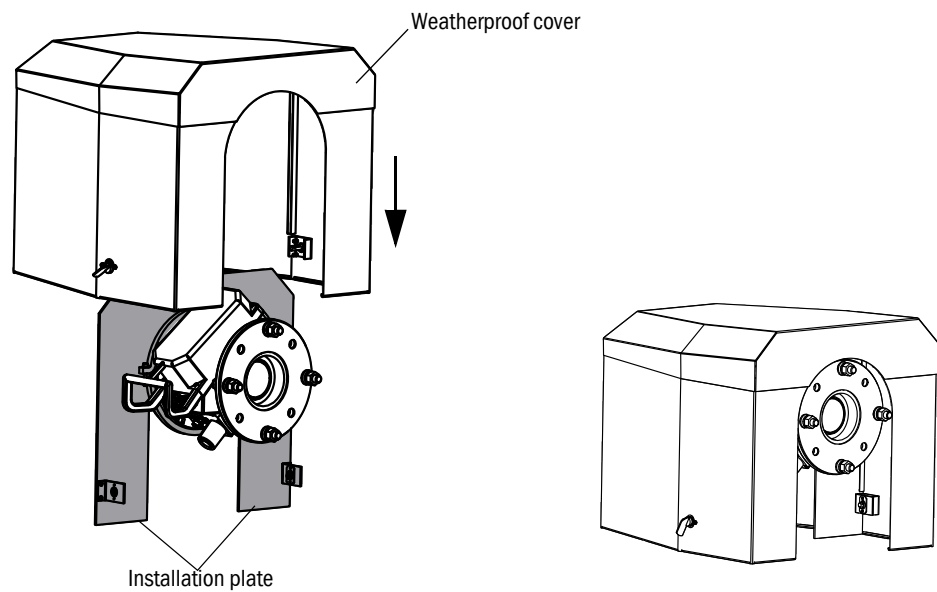

- ▶ Position the cover on the installation plate from the top.
- ▶ Engage the locks and close again.

5 Operation

5.1 Recognizing an unsafe operating state



CAUTION: Hazard through unsafe operational state

If the device is or could be in an unsafe state:

- ▶ Take the device out of operation, disconnect from the power voltage and signal voltage and secure against unallowed or accidental start-up.

Possible causes		Action
Smoke	escapes from the enclosure	<ul style="list-style-type: none"> ▶ Immediately put the device out of operation. ▶ Have the device repaired.
Gas	escapes from the enclosure	<ul style="list-style-type: none"> ▶ Immediately check whether the gas is noxious or combustible. ▶ <i>If this is the case:</i> Immediately follow the local Operating Instructions which control behavior during uncontrolled escape of gas. <p><i>Examples of behavior:</i></p> <ul style="list-style-type: none"> ▶ Trigger an alarm. Start emergency measures. ▶ Immediately evacuate all persons from the affected operational area. ▶ Use breathing protection. ▶ Stop the affected gas supply. ▶ Put the gas analyzer out of operation.
Moisture	penetrates the device	<ul style="list-style-type: none"> ▶ Immediately put the device out of operation. ▶ Locate and stop the liquid source. ▶ Have the device repaired.
Humidity	or moisture condensation on electrical connections	<ul style="list-style-type: none"> ▶ Immediately put the device out of operation. ▶ Have the device repaired.
Electric lines	are damaged or broken	<ul style="list-style-type: none"> ▶ Immediately put the device out of operation. ▶ Have the device repaired.
Surface	is damaged or deformed	<ul style="list-style-type: none"> ▶ Put the device out of operation. ▶ Have the device repaired. ▶ <i>If caused by heat from inside the device:</i> Immediately put the device out of operation. ▶ <i>If caused by acute external influence:</i> Locate the heat source and protect the device provisionally against heat. <ul style="list-style-type: none"> ▶ <i>Otherwise:</i> Have the device checked immediately by a skilled person.
Unusual noises	can be heard inside the device	<ul style="list-style-type: none"> ▶ Check malfunction displays and malfunction messages of the device. ▶ Have the device checked by a skilled person.
Malfunctions	remain inexplicable despite having been cleared	Inform the Endress+Hauser service department.

Table 9: Diagnosis table: Unsafe operating state

5.2 Operator panel

The operator panel is located on the right side of the SR-unit housing.

Fig. 26: Significance of display

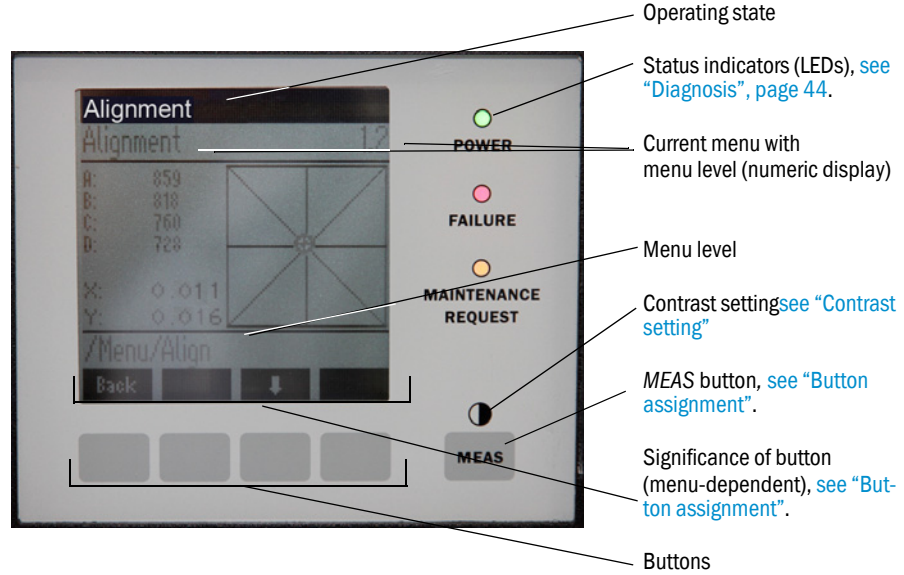

5.2.1 Status indicators (LEDs)

Significance of LEDs

- Green LED on: Power supply is in order.
- Yellow LED on: Maintenance request.
- Red LED on: Malfunction.



 Further information on LED significance, see "Diagnosis", page 44

5.2.2 Button assignment

Button assignment depends on the menu selected and is shown above the respective button.

Button assignment	Significance
MEAS	Returns to the display of the measured value screen from any menu All inputs that have not been terminated with Save are discarded
	If the MEAS button is depressed for more than 3 seconds: The contrast setting is displayed
Menu	Opens the main menu (menu tree)
Diag	Diag is shown only when there is a message. Press this button to show message. Further information on diagnosis, see "Diagnosis", page 44 List of error messages, see "Error messages", page 56
Enter	Opens the selected menu level
Save	Saves changed parameters
Start	Starts the displayed action

5.2.3 Contrast setting

- 1 Press the MEAS button for more than 3 seconds.
- 2 Set the desired contrast level with both middle buttons  and .

5.2.4 Language

Menu texts are shown in *English*.

5.2.5 Menu tree

1.1	Diagnosis	see "Diagnosis", page 44
1.1.1	Failure	see "Diagnosis", page 44
1.1.2	Maintenance (request)	see "Diagnosis", page 44
1.1.3	Uncertain	see "Diagnosis", page 44
1.1.4	Check cycle	see "Check cycle", page 45
1.2	Alignment check	see "Alignment check (automatic optical alignment check; option)", page 45
1.3	Adjustments	see "Adjustments", page 45
1.3.1	Alignment adjust	see page 45
1.3.2	Check cycle	see page 47
1.3.3	Reference cycle	see page 47
1.4	IP Configuration	View the IP settings
1.4.1	IP	IP address
1.4.2	M	Subnetmask
1.4.3	GW	Gateway
1.5	Maintenance	see "Maintenance", page 47

5.2.5.1 *Diagnosis*

The “Diagnosis” menu shows the current error messages.

- +i The GM32 signals a malfunction or an unsafe operational state with status signals (option) (→ electrical connection diagram).
- +i The GM32 creates a logbook.
 - ▶ Access to the logbook is performed exclusively via SOPAS ET
[see “SOPAS ET \(PC program\)”, page 11.](#)
- +i→ List of error messages and measures for clearing malfunctions
[see “Error messages”, page 56](#)

Status messages, status indicators and system states

Status	Status indicators (LED)	Significance	Measured value display	Analog outputs ^[1]	Status signal ^{[2],[3]}
Power On	Green	Power supply in order	---	---	---
Uncertain	Green, however, measured value blinks	Measured value uncertain (e.g. outside calibration range) Cause: Press the <i>DIAG</i> button All messages → SOPAS ET Logbook. Clearing Malfunctions, see “Error messages”, page 56	Current	Current	According to setting
Maintenance request	Yellow	Irregularities (e.g. gas temperature too high, deviation from check cycle too high) that require a review of the cause. The measured values are valid. Cause: Press the <i>DIAG</i> button All messages → SOPAS ET Logbook. Clearing Malfunctions, see “Error messages”, page 56	Current	Current	According to setting
Failure	Red	Device failure (e.g. lamp failed) Cause: Press the <i>DIAG</i> button All messages → SOPAS ET Logbook. Clearing Malfunctions, see “Error messages”, page 56	Last valid measured value held	Last valid measured value held	According to setting

Table 10 *Status messages, status indicators and system states*

[1] Option
 [2] Option. Refer to the delivered System Documentation for the assignment of the status outputs.
 [3] See SOPAS ET in the “Digital outputs” menu.

5.2.5.2 Check cycle

Results of the last check cycle.

Fig. 27: Check cycle

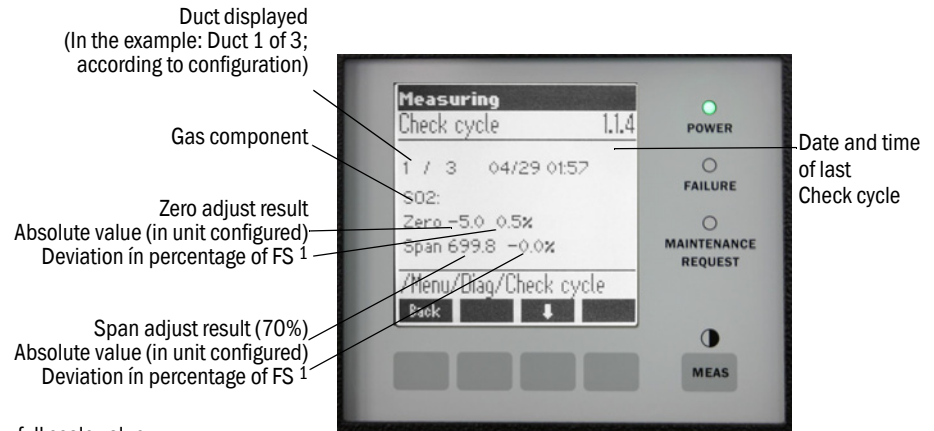

¹ FS = full scale value:
Scale limit value of the assigned analog output

5.2.5.3 Alignment check (automatic optical alignment check; option)

This menu serves to view the values of automatic optical alignment.



- ▶ Perform this check only when the SR-unit is at operating temperature (in operation for at least 30 minutes).
- ▶ Automatic mirror adjustment - do not perform manual adjustments.



Further information see "Adjustments", page 45

- ▶ Arrow buttons: Toggle between "deviation" and "performed steps of tracking mirror" displays.
- ▶ To exit the Menu item: Press the "Back" button.

5.2.5.4 Adjustments

Alignment adjustment (manual optical alignment)



- ▶ Perform this work only when the SR-unit is at operating temperature (in operation for at least 30 minutes).

Fig. 28: Manual alignment of optical axis

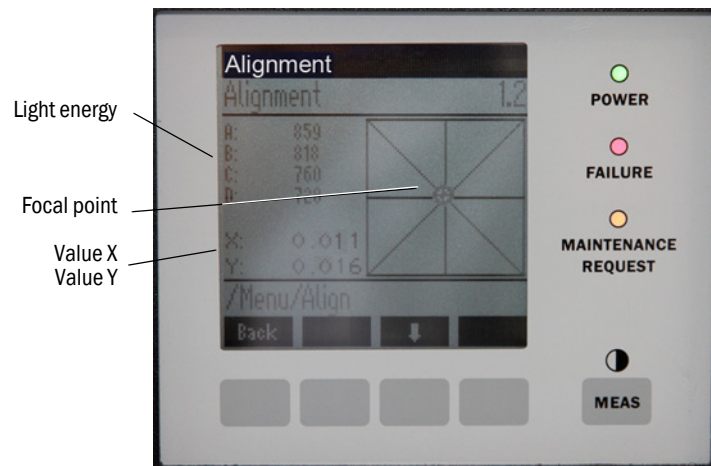

Manual optical alignment of the GM32.

- 1 Press the “Start” button: The GM32 switches to a defined state.
A crosshair with a focal point and X/Y values are shown on the screen.
- 2 Tolerances:
X: -0.05 ... +0.05
Y: -0.05 ... +0.05.

The focal point is then in the center of the crosshair.

Adjustment:

Adjust the optical alignment by turning both adjustment screws on the device flange of the SR-unit (19 mm wrench).



The display on the monitor reacts to the adjustment with a delay.

- ▶ Perform adjustments slowly and wait for approx. 20 seconds until the display on the monitor has been updated.

Fig. 29: Alignment on the device flange

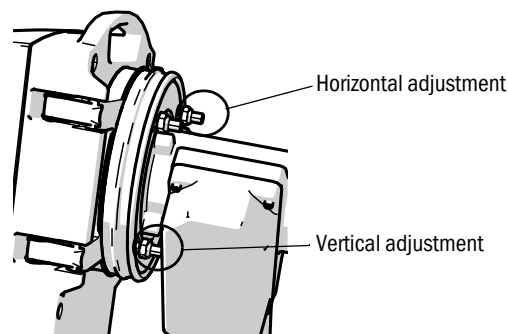

- Horizontal adjustment causes a horizontal adjustment of the focus.
 - Vertical adjustment causes a vertical adjustment of the focus.
- 3 The values for the light energy V1 .. V4 must be in the range 250 .. 500 and approximately have the same size.

If you cannot see a focal point or adjustment is not possible:

- Is the gap between the device flange and the purge air fixture correctly adjusted? (see [“Installing the device flange on the purge air fixture”](#), page 30).
- For GMP probe: Diaphragm (lever) open? (see [“Installing the SR-unit on the device flange”](#), page 36).
- Large amount of dust or humidity in the gas duct?
- Window dirty? (see [“Cleaning the window”](#), page 50).
- Sender lamp defective? (Replacing the sender lamp, see [“Checking and replacing the desiccant cartridges”](#), page 50).

Check cycle

Start the check cycle manually.



Information on the check cycle, see [“Check cycle”](#), page 11.

Reference cycle

Start the reference cycle manually.



Information on the reference cycle, see [“Reference cycle”](#), page 11.

5.2.5.5 Maintenance

Operating mode *“Maintenance”* is signaled via this menu.

- *“Maintenance”* is displayed in the operating mode line.
- The *“Maintenance mode active”* message is displayed.
- A continuous display of *“*”* is shown.
- The *“Maintenance”* status signal (→ electrical connection diagram) is set.

Fig. 30: *“Maintenance”* screen

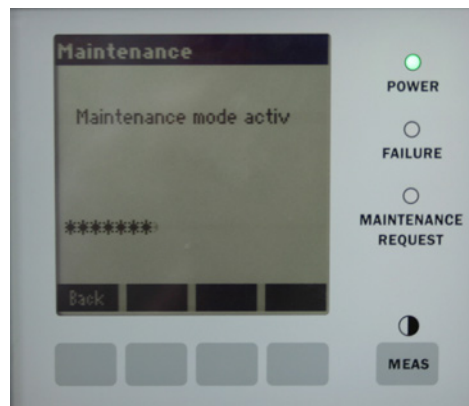

- Button assignment:
 - *“Back”*: Show the *“Measuring”* menu - maintenance signal remains set.
 - *“MEAS”*: Show the *“Measuring”* menu - maintenance signal is reset.

6 Maintenance

6.1 Maintenance plan (operator)

Maintenance task	Reference	w ^[1]	q ^[1]	h ^[1]	y ^[1]
Visual inspection	see “Visual inspection”, page 49		x	x	x
Cleaning the window	see “Cleaning the window”, page 50		x	x	x
Checking the desiccant cartridges, replace when necessary. Replace at the latest after 6 months.	see “Checking and replacing the desiccant cartridges”, page 50		x	x	x
Renewing the activated charcoal sachet	Endress+Hauser Service				x
Checking the purge air unit (for GMP probe)	see “Cleaning the purge air unit”, page 53		x	x	x
Checking optical alignment	see “Alignment check (automatic optical alignment check; option)”, page 45		x	x	x

Table 11: Maintenance plan

[1] w = weekly, q = quarterly, h = every half year, y = yearly

6.1.1 Recommended expendable and wearing parts for 2 years operation

Spare part	Number	Part number ^[1]
Sender lamp	2 pcs	2082776
Sender lamp GM32 LowNOx	2 pcs	2086187
Desiccant cartridge	8 pcs	2010549
Activated charcoal bag	2 pcs	5323946
Optical cleaning cloth	8 pcs	4003353
Filter insert for purge air unit	8 pcs	5306091

Table 12: Expendable and wearing parts

[1] Per piece

6.2 Preparation work



NOTE: Some tasks cause the GM32 to switch to malfunction

▶ Activate *Maintenance mode* before starting work, see page 47.



NOTE: Do not switch the purge air off

▶ Do not switch the purge air unit off as long as the SR-unit is still on the gas duct.



NOTE: With the GPP probe: Danger of condensation

▶ Do not switch off the heater of the GPP probe as long as the probe is in the gas duct.

6.3 Swiveling out and removing the SR-unit



WARNING: Damage to eyes through lamp beam

The lamp beam can cause eye damage when the SR-unit is open.

- ▶ Before opening the SR-unit: Switch the GM32 off at the external main power switch or wear suitable protective goggles.



WARNING: Danger resulting from escaping gas when the SR-unit is swiveled out

Excess pressure in the gas duct can cause hot and/or noxious gases to escape when the SR-unit is swiveled out.

- ▶ Swivel the SR-unit out only when you have taken suitable safety measures.
- ▶ For GMP probe: Set the lever on the purge air fixture to the “Close” position (see “Lever of the locking device (for GMP probe)”, page 36).



CAUTION: If the hinge pin has not been correctly inserted, the SR-unit can drop when swiveled out.

- ▶ Check that the hinge pin is completely pressed down before swiveling the SR-unit out, see “Install the SR-unit:”, page 36

Fig. 31: Swiveling the SR-unit out

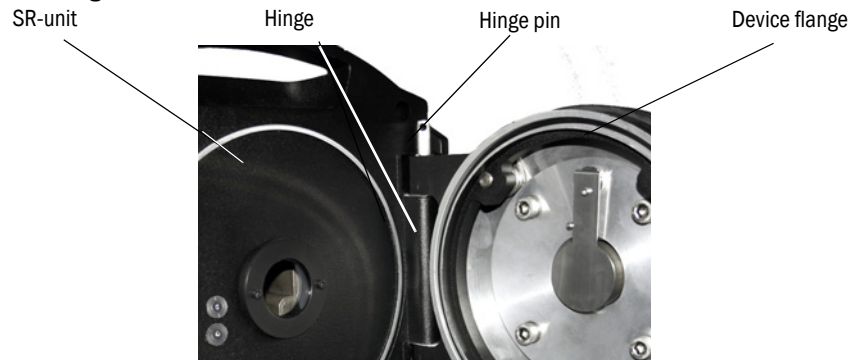

- 1 For GMP probe: Set the lever on the purge air fixture to the “Close” position, see “Lever of the locking device (for GMP probe)”, page 36.
- 2 Open the 4 quick-release fasteners of the SR-unit and swivel the SR-unit out.
- 3 To remove the SR-unit:
Hold the SR-unit tight, pull out the hinge pin and take the SR-unit off



NOTE: The SR-unit is heavy

- ▶ Hold the SR-unit tight when pulling out the pin.

6.4 Visual inspection

- ▶ Check the housings of the SR-unit housing and connection unit for mechanical damage.
- ▶ Clean the respective housings if contaminated.
- ▶ Check all cables for damage.
Pay attention to chafe marks and kinks on cable ducts.
- ▶ Check flanges and screw fittings for firm seating.

6.5 Cleaning the window

Fig. 32: SR-unit window

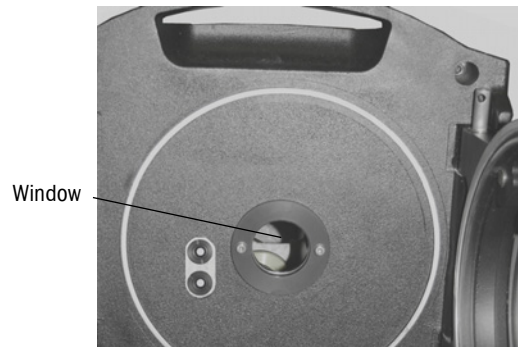

- 1 Swivel the SR-unit out, see [“Swiveling out and removing the SR-unit”](#), page 49.
- 2 Cleaning the window.
Use an optical cleaning cloth for cleaning.
The cleaning cloth can be moistened with demineralized water.
Do not use cleaning agents.
- 3 Close the SR-unit again.
- 4 For GMP probe: Set the lever on the purge air fixture to the “open” position again.

6.6 Checking and replacing the desiccant cartridges

Fig. 33: Desiccant cartridges

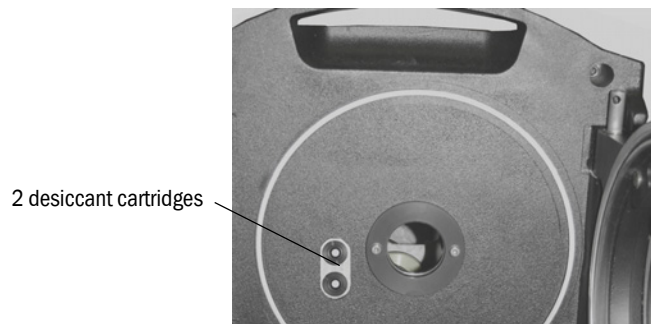

- 1 Swivel the SR-unit out, see [“Swiveling out and removing the SR-unit”](#), page 49.
- 2 Desiccant cartridge is *light blue*: Desiccant cartridge is dry.
Desiccant cartridge is *white*: Replace the desiccant cartridge.
- 3 Replacing the desiccant cartridge:
 - a) Unscrew the desiccant cartridge.
 - b) Screw in the new desiccant cartridge.
- 4 Close the SR-unit again.
- 5 For GMP probe: Set the lever on the purge air fixture to the “open” position again.

6.7 Replacing the sender lamp and LED for GM32 LowNOx

6.7.1 Tools required

Tools	Required for
Phillips screwdriver (0.5 x 3.0M)	Connect voltage supply line of sender lamp.
Allen (5 M)	Retaining screws of UV lamp
Allen (2,5 M)	Retaining screws of LED unit

Table 13: Tools required for exchange of lamps

6.7.2 Sender lamp with LED unit

Fig. 34: Description of sender lamp with LED unit

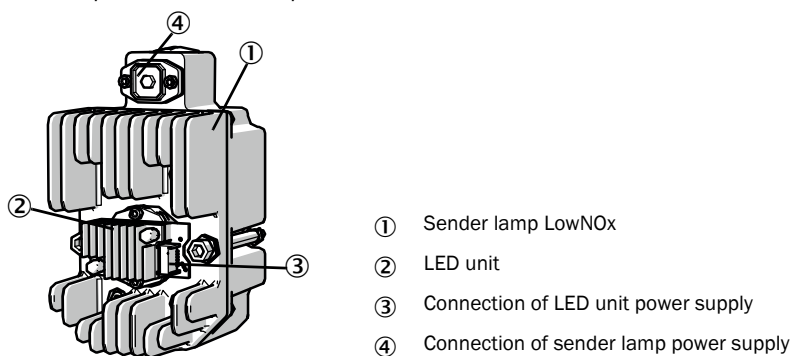

Removing the sender lamp with LED unit

- 1 Switch the GM32 off using the fuse fitted by the operator.
- 2 Loosen 5 screws on the rear side of the SR-unit and swivel the rear side out.
- 3 Pull off the lamp cover.

Fig. 35: Lamp cover

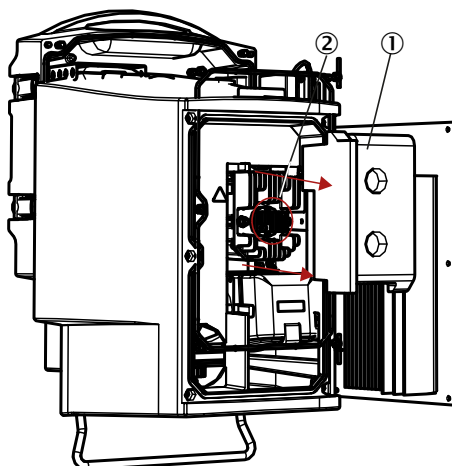

- ① Lamp cover
- ② LED unit

- 4 Pull off the voltage supply line of the LED.
- 5 Loosen screw (crosshead) of the plug of the sender lamp voltage supply and disconnect the plug.

Fig. 36: Sender lamp

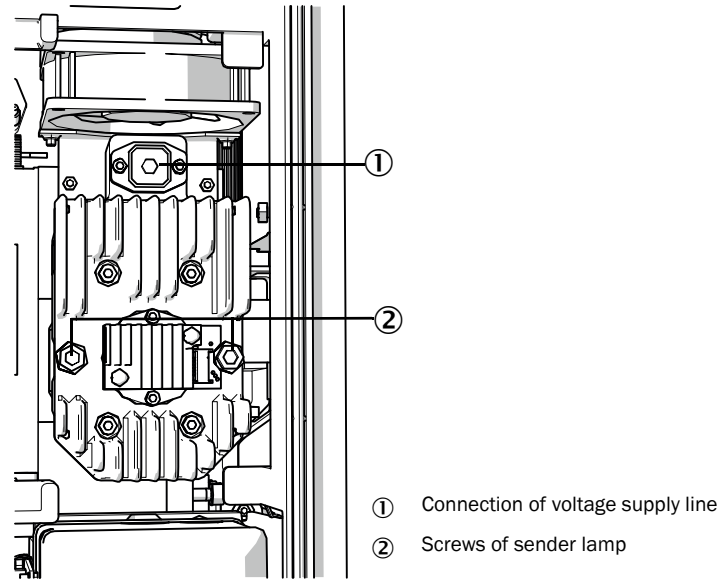

- 6 Optional: Loosen the 2 screws (5 mm Allen screw) on the sender lamp and take the sender lamp off.

Replacing the LED unit

Fig. 37: Remove the LED unit from the sender lamp

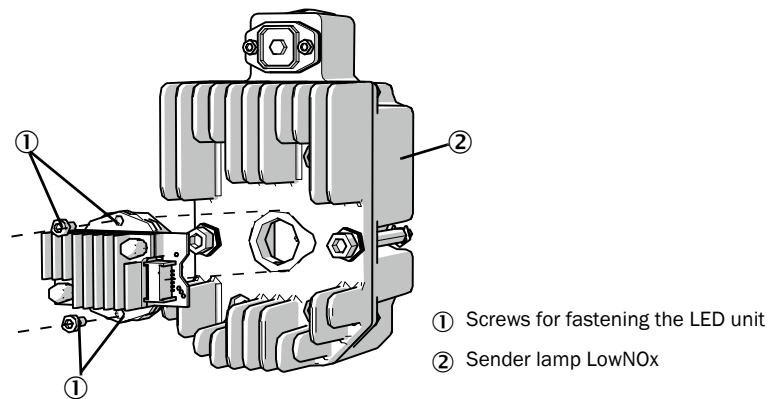

- 7 Loosen the two fastening screws of the LED unit and pull the LED unit off.



NOTE:

The fastening screws of the LED unit are not self-locking.



NOTE:

Risk of contamination of the optical mirrors in the device after removing the LED unit.
▶ Cover the opening to the optical mirror after removing the LED unit.



NOTE:

The optical surfaces can be contaminated when touched with your fingers.
▶ Avoid touching the optical surfaces with your fingers.

- 8 Plug in new LED unit and screw tight.

Replacing the sender lamp

**NOTE:**

Replacement of the sender lamp is identical for all GM32 variants.

- 1 Loosen both screws (5 mm Allen screw) on the sender lamp and take the sender lamp off, see [“Sender lamp”, page 52](#).
- 2 Remove the cap from the new sender lamp.
- 3 Plug in new sender lamp and screw tight.
- 4 Connect the plug and screw tight.
- 5 Plug in the lamp cover.
- 6 Screw the rear cover tight.

Adjustment is not required.

6.8 Cleaning the purge air unit

**NOTE: Inadequate purge air supply can damage the gas analyzer.**

- ▶ The purge air unit must be in perfect condition.

The filter of the purge air unit must be exchanged at the latest when the low-pressure monitor on the filter outlet triggers.

Preparation

- ▶ If the purge air unit is not immediately functional: Remove the SR-unit from the gas duct (swiveling out is sufficient for short-time work).

Procedure

- 1 Put the purge air unit out of operation and completely remove the purge air hoses.
- 2 Replace the air filter in the purge air unit and clean the inside of the purge air unit.



Details → [Data Sheet of purge air unit](#).

- 3 Fully swivel out the SR-unit so that any dust blown through the purge air hose is not deposited on the window.
- 4 Put the purge air unit back into operation, see [“For GMP probe: Start-up of the purge air supply”, page 33](#).

7 Clearing malfunctions

7.1 Safety instructions when clearing malfunctions

**CAUTION: General hazards caused by electrical voltage**

- ▶ *If it is necessary to open the device for adjustment or repair:* Disconnect the device from all power sources before starting work.
- ▶ *If the open device must be live during work:* This work has to be performed by skilled persons who are familiar with potential hazards. If it is necessary to remove or open internal components, live parts could be exposed.
- ▶ *If liquids have penetrated electrical components:* Put the device out of operation and disconnect the power voltage externally (e.g. disconnect the power cable). Then contact service technicians of the manufacturer or correspondingly trained skilled persons to have the device repaired.
- ▶ *If hazard-free operation of the device is no longer possible:* Put the device out of operation and secure against unauthorized start-up.
- ▶ Do not interrupt the protective conductor connections inside or outside the device.

**NOTE: Damage by voltage**

Before signal connections are established (also with plug connections):

- ▶ Disconnect the GM32 and any connected devices from the voltage supply. Otherwise the internal electronics can be damaged.

**WARNING: Hazard through overpressure in cavities!**

With GPP probes, overpressure can arise in the reflector compartment or in the gas lines, e.g., through deposits of penetrating liquid, when the probe comes into contact with the hot sample gas. Open connections carefully, make visual and continuity checks.

- ▶ Make regular visual and continuity checks of the cavities.
 - ▶ At the same time, take all precautionary measures described in the Operating Instructions when opening the connections.
-

7.2 Error diagnosis Tables

7.2.1 Device not functioning

Possible causes	Information
Power supply not connected.	▶ Check power cable and connections.
Main power supply has failed.	▶ Check power supply (e.g. socket, external disconnecting device).
Internal operating temperatures not correct.	▶ Check whether error messages exist.
Internal software not functioning.	Can only occur with complex internal malfunctions or after strong external influences (e.g. strong electromagnetic interfering pulse). ▶ Switch the GM32 off and back on again after a few seconds.

Table 14: Error diagnosis - device not functioning

7.2.2 Measured values clearly incorrect

Possible errors	Possible causes	Remedy
Leakages (on GPP probe).	---	▶ Have the GPP probe checked by Endress+Hauser Customer Service.
Sample gas penetrated the area before the SR-unit.	<ul style="list-style-type: none"> • Gas pressure in gas duct too high. • Purge air unit has failed or is too weak. 	▶ see "Sample gas penetrating", page 55.
For GPP probe: Temperature dropped below dewpoint.	---	▶ Check project planning.
Sample gas penetrates the purge air compartment.	<ul style="list-style-type: none"> • Gas pressure in gas duct too high. • Purge air unit has failed or is too weak. 	▶ see "Sample gas penetrating", page 55.
	<ul style="list-style-type: none"> • Probe gap alignment incorrect. Sample gas flow must not pressed into the purge air openings. 	▶ Check installation.
Sample gas conditions do not match, or no longer match, project planning.	<ul style="list-style-type: none"> • Plant condition has changed 	▶ Check sample gas conditions (temperature, moisture, concentration etc.).
GM32 not ready for operation.	---	▶ Check start-up ▶ Check status/error messages.
GM32 calibration is not correct.	---	Check: Were correct test gases used? Are setpoint values correct? If this does not help: Carry out a calibration (contact Endress+Hauser Service).
Analyzer is contaminated.	---	Report to manufacturer's Technical Service or trained skilled persons.

Table 15: Error diagnosis - incorrect measured values

7.2.3 Sample gas penetrating



NOTE: Sample gas in the analyzer can damage the analyzer.

Error	Possible causes	Remedy
Sample gas penetrating the area before the SR-unit.	<ul style="list-style-type: none"> Gas pressure in gas duct too high. 	<ul style="list-style-type: none"> ▶ Check project planning.
	<ul style="list-style-type: none"> Purge air unit has failed or is too weak. 	<ul style="list-style-type: none"> ▶ Check purge air unit. ▶ Plan redundant purge air unit. ▶ Strengthen purge air unit.
Sample gas penetrating the GMP probe.	<ul style="list-style-type: none"> Purge air unit has failed or is too weak. 	<ul style="list-style-type: none"> ▶ Check purge air unit ▶ Plan redundant purge air unit. ▶ Strengthen purge air unit.

Table 16: Error diagnosis - sample gas penetrating

7.2.4 Corrosion on probe or flanges

Error	Possible causes	Remedy
Corrosion on probe, filter cuvettes (GPP) or flanges	<ul style="list-style-type: none"> Unsuitable materials 	<ul style="list-style-type: none"> ▶ Check project planning.

Table 17: Error diagnosis - corrosion on flange

7.2.5 Measured value blinks

If a measured value blinks: Measured value is “uncertain” (e.g. calibration range exceeded).

For GMP probe: When all measured values blink: Is the lever for the diaphragm in the “open” position (see “Installing the SR-unit on the device flange”, page 36)?

7.3 Error messages

7.3.1 Example of an error message

Fig. 38: Example of an error message

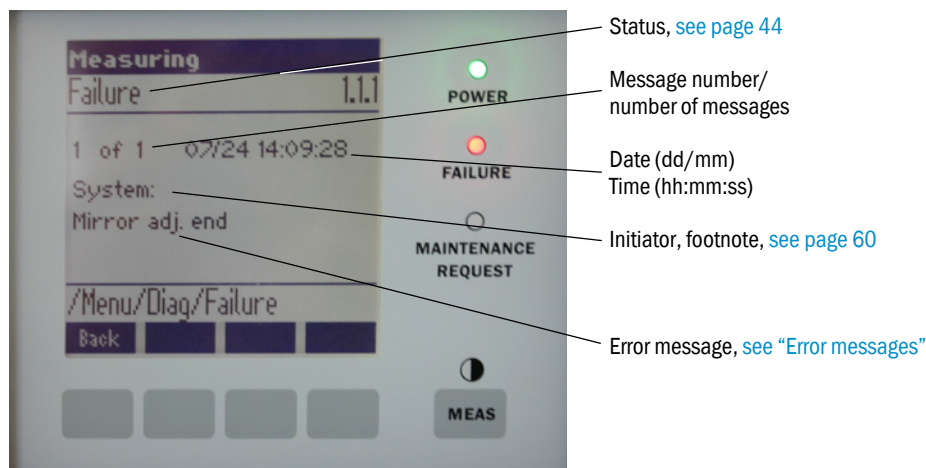

7.3.2 Error messages

Initiator ^[1]	Text	Classification	Description	Possible causes/remedy ^[2]
System	EEPROM	Failure	EEPROM parameters corrupted or not compatible after software upgrade.	Software upgrade: Reset parameters. Load saved parameters. Defect: Reload backup. Replace hardware, if possible.
	Spectro com.		Communication fault with spectrometer.	Contact Endress+Hauser Service.
	Zero com.		Communication fault with zero point reflector.	Contact Endress+Hauser Service.
	Temp control com.		Communication fault with temperature control unit.	Contact Endress+Hauser Service.
	Visor com.		Communication fault with visor module.	Contact Endress+Hauser Service.
	Filter com.		Communication fault with control filter element.	Contact Endress+Hauser Service.
	Mirror com.		Communication fault with mirror tracking.	Contact Endress+Hauser Service.
	Lamp com.		Communication fault with lamp electronics.	Contact Endress+Hauser Service.
	LED com.		Communication fault with LED electronics.	Contact Endress+Hauser Service.
	Visor fault		Error of visor signals. Signal distorted or zero.	Check signals and parameters.
	Visor values		Visor signals outside the valid range.	Hardware defect. Electronics not adjustable (amplification too high).
	Visor no signal		All 4Q signals below threshold parameter.	Check alignment, reflector, contamination.
	Lamp fault		Lamp does not go on.	Lamp is defective. Replace lamp, see “Checking and replacing the desiccant cartridges” , page 50.
	Mirror adj. End		Mirror tracking has reached maximum position.	Check alignment, see “Alignment check (automatic optical alignment check; option)” , page 45.
	Zero adj. mc adj.		Beam tracking during adjustment not possible.	Check alignment, see “Alignment check (automatic optical alignment check; option)” , page 45.
	Spectro para.		No correct parameters saved in spectrometer.	Contact Endress+Hauser Customer Service.
	Purge air signal		Digital input signals purge air error.	Check purge air supply, see “Cleaning the purge air unit” , page 53.
	Temp control out of range		Temperature regulation measurement outside the valid range.	Excess temperature switch-off active for temperatures > 70 °C. Switches back on automatically when < 65 °C.
	Extinction calc		Error in extinction calculation.	Contact Endress+Hauser Service.
	Reference calc		Error in reference calculation.	
	IIR Filter		Error during IIR filtering.	
Interpolation	Error in interpolation calculation.			
Eval modul com.	Error in communication with software evaluation module.			
File conditions	Error during condition file access.			
File espec	Error during extinction file access.			
File cact	Error during lambda coefficient file access.			
File measval	Error during measured value file access.			

Table 18 Error messages

Initiator ^[1]	Text	Classification	Description	Possible causes/remedy ^[2]
System	Lamp performance	Maintenance	Warning for lamp performance Lamp performance < 20%.	Prepare to exchange the lamp, see "Checking and replacing the desiccant cartridges", page 50.
	Lamp performance limit		Lamp performance too low.	Replace lamp, see "Checking and replacing the desiccant cartridges", page 50.
	Lamp minimum		During lamp adjustment, an excess signal was determined with minimum lamp current and exposure.	Check parameter settings.
	Lamp 4Q max		The lamp current must be set to 1000 mA (stop) in the alignment procedure.	Alignment, check the optics, see "Alignment check (automatic optical alignment check; option)", page 45. Possible lamp change, see "Checking and replacing the desiccant cartridges", page 50 or correct the parameter setting.
	LED performance		Lamp performance <20%	Replace LED module
	LED performance limit		Lamp performance near 0%	Replace LED module
	LED Peltier error		Peltier element defective (0 A)	Replace the LED
	LED temperature mismatch		Nominal temperature of 60 °C cannot be held.	<ul style="list-style-type: none"> Can occur during initialization / start phase (warm-up phase). Device temperature too high / too low. Replace LED modules
	Flashcard missing		No Flashcard found.	Insert the Flashcard, replace a possibly defective card.
	IO com.		Communication fault to IO block.	Connection interrupted, check the cable. Defective CAN-bus interface.
	Spectro no answer		No data received from spectrometer.	Malfunction on the interface to the spectrometer. Check the plug.
	Cycle span drift		The measurement on the control filters showed an excess deviation.	The reference from the adjustment is not correct. Check limit value parameter setting.
	Cycle zero drift		The zero point measurement of a measured value showed an excess deviation.	Check limit value parameter setting.
	Cycle wavelength drift		The check of the current Lambda_CO coefficient showed an excess deviation.	Check limit value parameter setting.
	Cycle peak position		The check of the position of the peak of the NO cell showed an excess deviation.	Check limit value parameter setting. Defective NO cell.
	Cycle peak width		The check of the peak width of the NO cell showed an excess deviation.	Check limit value parameter setting. Defective NO cell.
	Cycle cell empty		During the check of the NO cell it is determined that the highest measured extinction value in the evaluation range is smaller than 0.1.	Cell is empty.
	Temp control voltage low		The measured voltage supply value is too small (< 20 V).	Malfunction of temperature control unit.
	Temp control lamp fan		The lamp fan has a malfunction.	Malfunction of temperature control unit or fan or cabling.
	Temp control optic fan		The fan of the optic carrier has a malfunction.	Malfunction of temperature control unit or fan or cabling.
	Temp control spectro fan		The fan of the spectrometer has a malfunction.	Malfunction of temperature control unit or fan or cabling.
	Temp control electronic temp		The temperature of the temperature control electronics exceeds 100 °C.	Malfunction of temperature control unit.
	Temp control spectro temp		SR-unit is too warm or too cold.	In the heating phase: Normal. When running: Check ambient temperature.
Data logging: writing data	Error when writing logging data to the Flashcard.	Flashcard memory full, Flashcard defective.		
Data logging: open file	Error when opening a file for logging data on the Flashcard.	Flashcard memory full, Flashcard defective.		
System I/O Error	Error in "Modular I/O System".	Incorrect configuration of I/O module or I/O module defective.		

Table 18 Error messages

Initiator ^[4]	Text	Classification	Description	Possible causes/remedy ^[2]	
Probe	EL. too hot	Maintenance	Electronics too hot. Ambient temperature too high?	Allow device to cool down.	
	Air purge low		Volume flow below set limit.	Check purge air supply.	
	Filter watch		Flow monitor.	Check purge air supply.	
	p no signal		No signal from pressure sensor.	Check purge air supply.	
	p out of range		Sample gas pressure < 500 or > 1200 hPa (mbar).	—	
	t air no signal		Broken sensor.	Please contact Endress+Hauser Customer Service.	
	[t] no signal		Broken sensor.		
	EEPROM defect		EEPROM defective.		
	Heat no signal		Heater fault.		
	Heater < 1.5 A				
	Heater defect				
Heating too low					
No com.		Communication error to optic head and/or reflector.	Check connection cables.		
System	Systemstart	Extended	This message is entered during each system start.	Shows when last system start was made.	
	Zero adjust		The start of an adjustment is recorded in the logbook.	Shows when last adjustment was made.	
	Boxmeasuring		The start of filter box measurement is recorded in the logbook.	Shows when last filter box measurement was made.	
	Reflector search		Search for reflector failed	Check alignment, see “Alignment check (automatic optical alignment check; option)” , page 45. Reflector contaminated or defective. Light intensity weakness too strong on measuring path.	
P	Substitute value	Maintenance	Calculation is made with a substitute value because of a pressure measurement error.	The set input (probe, analog input, SCU) shows errors and the substitute value is therefore used for calculation.	
T	Substitute value	Maintenance	Calculation is made with a substitute value because of a temperature measurement error.	The set input (probe, analog input, SCU) of pressure measurement shows errors and the substitute value is therefore used for calculation.	

Table 18 Error messages

Initiator ^[1]	Text	Classification	Description	Possible causes/remedy ^[2]	
Gas component	Bad Config. (text)	Failure	Error in calculation models.	Please contact Endress+Hauser Customer Service.	
	File I/O (text)		Error in file system.	Restart system. If the error continues to exist: Please contact Endress+Hauser Customer Service.	
	Measurement range x	Xtended	Current measuring range x (x = 1 .. 8)	—	
	Measurement value out of range	Uncertain	Measured value outside calibration range.	Check measured values for plausibility.	
	Measurement value range warning	Xtended	Measurement beyond a warning threshold defined during calibration.		
	Medium pressure out of range	Uncertain	Sample gas pressure outside calibrated range.	Check sample gas pressure.	
	Medium pressure warning	Xtended	Sample gas pressure beyond warning threshold.		
	Medium temperature out of range	Uncertain	Sample gas temperature outside calibrated range.	Check sample gas temperature.	
	Medium temperature warning	Xtended	Sample gas temperature beyond warning threshold.		
	Absorption range warning	Xtended	Absorption in active measuring path above warning threshold. Standard setting of warning threshold: 1.8 extinction units.	Check: - Window dirty see “Cleaning the window” , page 50 - Dust content in sample gas too high? - Sample gas concentration too high?	
	Absorption out of range	Failure	Absorption in active measuring path too high. Standard setting of error threshold: 2 extinction units.		
	Syntax error			Error in concentration calculation.	Please contact Endress+Hauser Customer Service.
	Processing error				
	Numerical (DivZero)				
	Numerical (lppError)				
	Numerical (MatSing)				
OS error (text)					
Spectr. resolution out of range			Resolution of spectrometer wrong.	Please contact Endress+Hauser Customer Service.	
Spectral evaluation			Uncertain		Error in calculation of spectra.

Table 18 Error messages

[1] System = SR-unit
 Probe = probe
 P = pressure sensor
 T = temperature sensor
 Gas component

[2] This Table also contains recommended solutions that can only be performed by specially trained personnel.

7.4 Inadequate purge air supply (for GMP probe)



NOTE: Inadequate purge air supply can damage the gas analyzer.

- ▶ If there are signs of incorrect purge air supply, immediately perform the measures listed below.

Indications of inadequate purge air supply

- Unusual noise from the area of the purge air unit.
- On systems with pressure difference sensor: An appropriate error message occurs.
- Rise in enclosure temperature.
- Unusually rapid contamination of the GM32 window.

Check the purge air unit

- ▶ Remove the purge air hose on the SR-unit: A strong air flow must be noticeable.
- ▶ Reinstall the purge air hose immediately.

Measures if purge air supply is inadequate

- ▶ If the purge air unit is not immediately functional: Remove the SR-unit from the gas duct (swiveling out is sufficient for short malfunctions).
- ▶ Immediately restore correct operation of the purge air unit or replace provisionally by a different purge air supply with at least the same purge air throughput.

Information for fast correction of faults

- Air filter of purge air unit clogged?
- Purge air hose slipped off or broken?
- Power supply of purge air unit failed?

7.5 Malfunctions on the connection unit

A green LED lights on each power supply unit in the connection unit.

If no LED lights: Check the voltage supply of the connection unit.

Otherwise, please contact Endress+Hauser Customer Service.

8 Shutdown

8.1 Shutdown



WARNING: Hazard resulting from gases in the gas duct

Hot and/or noxious gases can escape during work on the gas duct, depending on the plant condition.

- ▶ Work on the gas duct may only be performed by skilled persons who, based on their technical training and knowledge as well as knowledge of the relevant regulations, can assess the tasks given and recognize the hazards involved.



NOTE: Do not switch the purge air off immediately

- ▶ Do not switch the purge air unit off as long as the SR-unit is still on the gas duct.



NOTE: With the GPP probe: Danger of condensation

- ▶ Do not switch off the heater of the GPP probe as long as the probe is in the gas duct.



WARNING: Hazard through overpressure in cavities!

With GPP probes, overpressure can arise in the reflector compartment or in the gas lines, e.g., through deposits of penetrating liquid, when the probe comes into contact with the hot sample gas. Open connections carefully, make visual and continuity checks.

- ▶ Make regular visual and continuity checks of the cavities.
- ▶ At the same time, take all precautionary measures described in the Operating Instructions when opening the connections.

8.1.1 Shutdown

- ▶ Switch off the power supply of the connection unit.

The analyzer can remain on the gas duct as long as the purge air supply (for GMP probe) or the heater (for GPP probe) is in operation.



NOTE: In case of a failure, no message by the analyzer

- The analyzer no longer outputs a message when the purge air supply or the heater fails.
- ▶ Install suitable monitoring or remove the subassemblies.

8.1.2 Disassembly

Material required	Part number	Required for
Personal protective equipment	--	Protection when working on the stack
Flange cover	--	Covering the flange

Table 19: Material required for disassembly

- 1 Disconnect all connections between connection unit and SR-unit.
- 2 Remove the SR-unit, see [“Swiveling out and removing the SR-unit”, page 49.](#)



WARNING: Hazards when removing the SR-unit

- ▶ Observe the information concerning removal of the SR-unit, see [“Swiveling out and removing the SR-unit”, page 49.](#)

- 3 Unscrew the purge air fixture or flange fixture (see [“GM32 Probe \(version shown: GMP measuring probe\)”, page 13](#)) from the flange, pull out the probe and lay it down.



WARNING: Measuring probe can be hot

When the temperatures in the gas duct are high, the removed measuring probe is hot.

- ▶ Wear suitable heat-resistant gloves.
- ▶ Provide a heat-resistant support.

- 4 For GPP probe: Switch off the power supply of the heater.
- 5 For GMP probe: Switch the purge air supply off and disconnect the purge air hose on the device flange.
- 6 Close off the flange on the gas duct with a cover.

8.2 Storage

- 1 Clean the exterior of all housings, the measuring probe and all further components including the purge air unit (when fitted) with damp cleaning cloths. A mild cleaning agent can be used.
- 2 Check the desiccant cartridges and replace, if required, [see “Checking and replacing the desiccant cartridges”, page 50](#).
- 3 Protect the openings of the SR-unit and the reflector unit from atmospheric influences (preferably with the transport safety devices, according to [see “Transport safety devices”, page 29](#)).
- 4 Pack the GM32 for storage or transport (preferably in the original packing).
- 5 Store the GM32 in a dry, clean room.

8.3 Environmentally compatible disposal/recycling

The GM32 can be disposed off as industrial waste.



- Observe relevant local conditions for disposal of industrial waste.
-

The following subassemblies could contain substances that have to be disposed of separately:

- Electronics: Capacitors, rechargeable batteries, batteries.
- Display: Liquid of LC display.
- Probes: Probes can be contaminated with pollutants.

9 Specifications

9.1 Conformities

The technical design of this instrument complies with the following EC directives and EN standards:

- EC Directive LVD 2006/95/EC
- EC Directive EMC 2004/108/EC



Applied EN standards:

- EN 61010-1, Safety requirements for electrical equipment for measurement, control and laboratory use
- EN 61326, Electrical equipment for measurement technology, control technology and laboratory use - EMC requirements
- EN 14181, Calibration of continuously operating emission measuring devices
- EN 15267-3: Certification of automated measuring systems - Part 3
- EN 60068: Shock and vibration

9.1.1 Electrical protection

- Insulation: Class of protection 1 in accordance with EN 61140.
- Insulation coordination: Overvoltage category II in accordance with EN61010-1
- Contamination: The control unit operates safely in an environment up to contamination level 2 in accordance with EN 61010-1 (usual, non-conductive contamination and temporary conductivity by occasional moisture condensation)

9.2 System: GM32

9.2.1 System GM32 Standard

Description	Performance-tested in-situ-gas analyzer
Measured variable	NO, NO ₂ , NH ₃ , SO ₂
TÜV tested measured variable	NO, SO ₂
Maximum number of measured variables	4 (plus process temperature and pressure).
Measuring principle	Differential Optical Absorption Spectroscopy (DOAS)
Measuring ranges	<p>NH₃: 0 ... 30 ppm / 0 ... 2,600 ppm (+/- 2% of FS) NO: 0 ... 40 ppm / 0 ... 1,900 ppm (+/- 2% of FS) NO₂: 0 ... 50 ppm / 0 ... 1,000 ppm (+/- 2% of FS) LowNO₂ (Option): 0 ... 15 ppm / 0 ... 1,000 ppm (+/- 2% of FS) SO₂: 0 ... 15 ppm / 0 ... 7,000 ppm (+/- 2% of FS)</p> <p>Measuring ranges refer to 1 m measuring path Measuring ranges depending on application and device version Caution: Specification refers to:</p> <ul style="list-style-type: none"> - Dust-free gas - No cross-sensitivities - Gas temperature: 70 °C
Certified measuring ranges	<p>NO: 0 ... 70 mg/m³ / 0 ... 700 mg/m³ SO₂: 0 ... 75 mg/m³ / 0 ... 1,000 mg/m³</p> <p>With an active measuring path length of 1.25 m (GMP measuring probe). The measuring probe (GPP) which can be gas tested is not TÜV performance tested.</p> <p>LowNOx version</p> <ul style="list-style-type: none"> ● NO: Certification range: 0 ... 70 mg/m³ / 0 ... 700 mg/m³ / 0 ... 1302 mg/m³ ● SO₂: Certification range: 0 ... 75 mg/m³ / 0 ... 1,000 mg/m³ / 0 ... 2500 mg/m³ <p>For an active measuring path of 1 m (GMP measuring probe) The gas testable measuring probe (GPP) is not TÜV performance tested</p>
Response time (t ₉₀)	<p>GMP measuring probe: ≥ 5 s, adjustable Gas-testable measuring probe (GPP): ≥ 120 s, adjustable TÜV performance test: ≥ 30 s, adjustable</p>
Precision	<p>NH₃: ≥ 0.7 ppm NO: ≥ 0.8 ppm NO₂: ≥ 2.5 ppm SO₂: ≥ 0.3 ppm</p> <p>Relative to the smallest measuring range</p>
Ambient temperature	<p>-20 °C ... +55 °C Temperature change max. ±10 °C/h</p>
Storage temperature	<p>-20 °C ... +55 °C Temperature change max. ±10 °C/h</p>
Ambient humidity	<p>≤ 96% Relative humidity; moisture condensation on optical interfaces not allowed.</p>
Conformities	<p>Approved for plants requiring approval: 2001/80/EC (13th BImSchV) 2000/76/EC (17th BImSchV) 27th BImSchV TI Air EN 15267 EN 14181 MCERTS GOST</p>
Electrical safety	CE

Table 20: Technical data GM32 system standard Probe version

Degree of protection	Standard: IP 65, IP 69K
Operation	Via integrated control unit or SOPAS ET software.
Correction functions	Internal contamination correction
Control functions	Internal zero point control Check cycle for zero and span point according to QAL3
Options	SCU control unit

Table 20: (Continued) Technical data GM32 system standard Probe version

9.2.2 System GM32 TRS-PE

Description	In-situ gas analyzer for TRS monitoring in the force-pulp process
Measured variable	NO, NH ₃ , SO ₂ , CH ₃ SH, (CH ₃) ₂ S, (CH ₃) ₂ S ₂ , H ₂ S, TRS
Maximum number of measured variables	8 (plus process temperature and pressure).
Measuring ranges	NH ₃ : 0 ... 30 ppm / 0 ... 50 ppm NO: 0 ... 40 ppm / 0 ... 150 ppm SO ₂ : 0 ... 15 ppm / 0 ... 21 ppm H ₂ S: 0 ... 16 ppm / 0 ... 33 ppm CH ₃ SH: 0 ... 7 ppm / 0 ... 23 ppm (CH ₃) ₂ S: 0 ... 5 ppm / 0 ... 18 ppm (CH ₃) ₂ S ₂ : 0 ... 6 ppm / 0 ... 12 ppm TRS: 0 ... 26 ppm / 0 ... 65 ppm Measuring ranges refer to 1 m measuring path Measuring ranges depending on application and device version TRS = H ₂ S + CH ₃ SH (als H ₂ S-equivalent) For device variant 7: TRS = H ₂ S + CH ₃ SH + (CH ₃) ₂ S + 2x (CH ₃) ₂ S ₂
Response time (t ₉₀)	Gas-testable measuring probe (GPP): ≥ 120 s, adjustable Adjustable
Precision	NH ₃ : ≥ ± 0.7 ppm NO: ≥ ± 0.8 ppm SO ₂ : ≥ ± 0.3 ppm H ₂ S: ≥ ± 0.7 ppm CH ₃ SH: ≥ ± 0.5 ppm (CH ₃) ₂ S: ≥ ± 0.4 ppm (CH ₃) ₂ S ₂ : ≥ ± 0.3 ppm TRS: ≥ ± 1.4 ppm
Ambient temperature	-20 °C ... +55 °C Temperature change max. ±10 °C/h For device variant 7: +20 °C ... +30 °C
Storage temperature	-20 °C ... +55 °C Temperature change max. ±10 °C/h
Ambient humidity	≤ 96% Relative humidity; moisture condensation on optical interfaces not allowed.
Electrical safety	CE
Degree of protection	Standard: IP 65, IP 69K
Operation	Via integrated control unit or SOPAS ET software.
Correction functions	Internal contamination correction
Control functions	Internal zero and span point test
Options	SCU control unit

Table 21: Technical data GM32 system TRS-PE

9.2.3 Sender/receiver unit

Description	Analyzer unit of the measuring system
Operation	Via integrated control unit
Dimensions (W x H x D)	315 mm x 580 mm x 359 mm
Weight	20 kg

Table 22: Technical data sender/receiver unit

9.2.4 Open measuring probe (GMP)

Description	Measuring probe in open design version with integrated purge air guidance system
Process temperature	≤ +550 °C Versions for higher temperatures on request
Process pressure	-60 hPa ... 60 hPa Relative
Dimensions (W x H x D)	See dimension drawings
Weight	25 kg
Material, media contact	Stainless steel 1.4571, stainless steel 1.4539
Auxiliary gas connections	Purge air
Built-in components	Pressure sensor (not in Ex version) Temperature sensor PT1000 (not in Ex version) Flow monitor (purge air feed monitor, not in Ex version)

Table 23: Technical data open measuring probe (GMP)

9.2.5 Gas-testable measuring probe (GPP)

Description	Measuring probe with gas permeable filter element for adjustment with test gas
Process temperature	With ceramic filter: ≤ +430 °C With teflon filter: ≤ +200 °C
Process pressure	-60 hPa ... 60 hPa Relative
Dimensions (W x H x D)	See dimension drawings
Weight	45 kg
Material, media contact	Stainless steel 1.4571, stainless steel 1.4539, ceramic, PTFE
Power supply	
Voltage	115 V / 230 V
Frequency	50 Hz / 60 Hz
Power input	≤ 150 W
Auxiliary gas connections	Test gas Purge air
Built-in components	Pressure sensor Temperature sensor PT1000

Table 24: Technical data gas-testable measuring probe (GPP)

9.2.6 Connection unit

Description	Serves for on-site connection of the power supply and of data and signal cables.
Analog outputs	2 outputs: 0/4 ... 22 mA, 500 Ω Per module, modules can be selected and extended as required.
Analog inputs	2 inputs 0/4 ... 22 mA, 100 Ω Per module, modules can be selected and extended as required.
Digital outputs	4 outputs: 48 V AC/DC, 0.5 A, 25 W Per module, modules can be selected and extended as required.
Digital inputs	4 inputs 3.9 V, 4.5 mA, 0.55 W Per module, modules can be selected and extended as required.
Interfaces / Bus protocols Ethernet Ethernet Ethernet RS-485	Modbus TCP OPC SOPAS-ET Modbus RTU (via optional interface module)

Table 25: Technical data connection unit



Further information and technical specifications for the GM32 system and its components can be found in the following documentation:

- Technical Information GM32, measuring probe version
- Operating instructions, purge air unit SLV4
- Control unit SCU: See Operating Instructions SCU
- Operating Instructions Modular I/O System

Connections SCU I/O	
Relay contact <-> PE	860 V AC
Relay contact <-> relay contact	860 V AC
Relay contact <-> actuation	1376 V AC

Table 26: Characteristic data for electric isolation

9.3 Modbus Register Mapping

9.3.1 Mapping of GM32 measuring components

- Modbus register for 16 components



- Address, address start and address end of further components (component 4, component 5, ...) are each incremented with 17, the sequence of the items remains the same.
- The sequence of the components depends on the GM32 configuration.

Name	Item	Address		Data type	Register type	Comment
		Start	Width			
	Measured Value	5000	2	32 Bit float	Input register	Measuring value
	Status	5002	1	16 Bit integer	Input register	Status ⁰⁾
	Zero Point Value	5003	2	32 Bit float	Input register	Zero point
	Span Point Value	5005	2	32 Bit float	Input register	Span point
	Start of measuring range	5007	2	32 Bit float	Input register	min of range
	End of measuring range	5009	2	32 Bit float	Input register	max of range
	Regression coefficient C0	5011	2	32 Bit float	Input register	Offset
	Regression coefficient C1	5013	2	32 Bit float	Input register	Slope
	Regression coefficient C2	5015	2	32 Bit float	Input register	Correction factor
	Measured Value	5017	2	32 Bit float	Input register	Measuring value
	Status	5019	1	16 Bit integer	Input register	Status ⁰⁾
	Zero Point Value	5020	2	32 Bit float	Input register	Zero point
	Span Point Value	5022	2	32 Bit float	Input register	Span point
	Start of measuring range	5024	2	32 Bit float	Input register	min of range
	End of measuring range	5026	2	32 Bit float	Input register	max of range
	Regression coefficient C0	5028	2	32 Bit float	Input register	Offset
	Regression coefficient C1	5030	2	32 Bit float	Input register	Slope
	Regression coefficient C2	5032	2	32 Bit float	Input register	Correction factor
	Measured Value	5034	2	32 Bit float	Input register	Measuring value
	Status	5036	1	16 Bit integer	Input register	Status ⁰⁾
	Zero Point Value	5037	2	32 Bit float	Input register	Zero point
	Span Point Value	5039	2	32 Bit float	Input register	Span point
	Start of measuring range	5041	2	32 Bit float	Input register	min of range
	End of measuring range	5043	2	32 Bit float	Input register	max of range
	Regression coefficient C0	5045	2	32 Bit float	Input register	Offset
	Regression coefficient C1	5047	2	32 Bit float	Input register	Slope
	Regression coefficient C2	5049	2	32 Bit float	Input register	Correction factor

Table 27: Modbus component register (for the first 3 components)

9.3.2 Mapping for GM32 in general

- Modbus register for output signals, valid for all measured components

Item	Address		Data type	Register type	Comment
	Start	Width			
Year of current date	5272	1	16 Bit integer	Input register	> 2000 ¹⁾
Month of current date	5273	1	16 Bit integer	Input register	1 - 12 ¹⁾
Day of current month	5274	1	16 Bit integer	Input register	1 - 31 ¹⁾
Hour of current time	5275	1	16 Bit integer	Input register	0 - 23 ¹⁾
Minute of current time	5276	1	16 Bit integer	Input register	0 - 59 ¹⁾
Second of current time	5277	1	16 Bit integer	Input register	0 - 59 ¹⁾
Failure [collective]	5278	2	32 Bit integer	Input register	Bit Field ²⁾
Maintenance required [collective]	5280	2	32 Bit integer	Input register	Bit Field ³⁾
Check [collective]	5282	2	32 Bit integer	Input register	Bit Field ⁴⁾
Out of Spec. [collective]	5284	2	32 Bit integer	Input register	Bit Field ⁵⁾
Extended [collective]	5286	2	32 Bit integer	Input register	Bit Field ⁶⁾
Pressure	5288	2	32 Bit float	Input register	
Temperature	5290	2	32 Bit float	Input register	
Humidity	5292	2	32 Bit float	Input register	
Lamp Current	5294	2	32 Bit float	Input register	Lamp pulse (mA)
Lamp Integration	5296	2	32 Bit float	Input register	Exposure (ms)
Temperature Optic Housing	5298	2	32 Bit float	Input register	
Temperature Spectrometer	5300	2	32 Bit float	Input register	
Lamp performance	5302	2	32 Bit float	Input register	
Operating state	5304	1	16 Bit integer	Input register	8)
Year of last Check cycle	5305	1	16 Bit integer	Input register	> 2000 ⁹⁾
Month of last Check cycle	5306	1	16 Bit integer	Input register	1 - 12 ⁹⁾
Day of last Check cycle	5307	1	16 Bit integer	Input register	1 - 31 ⁹⁾
Hour of last Check cycle	5308	1	16 Bit integer	Input register	0 - 23 ⁹⁾
Minute of last Check cycle	5309	1	16 Bit integer	Input register	0 - 59 ⁹⁾
Second of last Check cycle	5310	1	16 Bit integer	Input register	0 - 59 ⁹⁾
LED Current	5311	1	16 Bit integer	Input register	0 - 200 (mA)
LED performance	5312	1	16 Bit integer	Input register	0 - 100 (%)

Table 28: Modbus "Common Out" register

9.3.3 Mapping of Modbus input values

- Modbus register for input signals, valid for all measured components

Item	Address	Width	Data type	Register type	Comment
	Start	Width			
Pressure	6000	2	32 Bit float	Holding register	
Temperature	6002	2	32 Bit float	Holding register	
Humidity	6006	2	32 Bit float	Holding register	
Password	6900	3	string	Holding register	
Pressure valid flag	6000	1	1 Bit	Coil	sticky ¹⁰⁾
Temperature valid flag	6001	1	1 Bit	Coil	sticky ¹⁰⁾
Humidity valid flag	6002	1	1 Bit	Coil	sticky ¹⁰⁾
Maintenance switch	6003	1	1 Bit	Coil	sticky ¹⁰⁾
Trigger control cycle	6004	1	1 Bit	Coil	momentary ¹¹⁾
Supress control cycle	6005	1	1 Bit	Coil	sticky ¹⁰⁾

Table 29: Modbus input register

- 0) Bit field, please see Table "Status" for details, see ["Bitmap "Status" , page 71.](#)
- 1) Current date and time of the device in ISO8601 format.
- 2) Bit field, please see Table "Failure" for details, see ["Bitmap "Failure" , page 72](#)
- 3) Bit field, please see Table "Maintenance request" for details, see ["Bitmap "Maintenance Request" , page 72](#)
- 4) Bit field, please see Table "Function check" for details, see ["Bitmap Table for "Function Check" and "Out of Specification" , page 72.](#)
- 5) Bit field, please see Table "Out of Spec" for details.see ["Bitmap Table for "Function Check" and "Out of Specification" , page 72](#)
- 6) Bit field, please see Table "Extended" for details, see ["Bitmap Table for extended functions" , page 73](#)
- 8) For Table of operating states please see Table "Operating states" for details, see ["Table "Operating states" , page 73](#)
- 9) Date and time of last control check cycle for all components of the GM32
- 10) Sticky: functions like a switch
- 11) Momentary: functions like a push button

9.3.4 Table Bitmap "Status"

Bit No.	Name	Comment
0	Failure	Bit=1: active
1	Maintenance request	Bit=1: active
2	Function Check	Bit=1: active
3	Out of Spec	Bit=1: active
4	Extended	Bit=1: active
5	Under range	Bit=1: active
6	Over range	Bit=1: active
7	Maintenance	Bit=1: active

Bit No.	Name	Comment
8	Check cycle	Bit=1: active
9	Reserved	Bit=1: active
10	Reserved	Bit=1: active
11	Reserved	Bit=1: active
12	Reserved	Bit=1: active
13	Reserved	Bit=1: active
14	Reserved	Bit=1: active
15	Reserved	Bit=1: active

Table 30: Bitmap "Status"

9.3.5 Bitmap Table “Failure”

Bit No.	Name	Comment
0	EEPROM	Bit=1: active
1	Spectro com.	Bit=1: active
2	Zero com.	Bit=1: active
3	Extinction calc	Bit=1: active
4	Reference calc	Bit=1: active
5	IIR Filter	Bit=1: active
6	Interpolation	Bit=1: active
7	Filter com.	Bit=1: active
8	Mirror com.	Bit=1: active
9	Visor fault	Bit=1: active
10	Visor values	Bit=1: active
11	Zero adj. mc adj.	Bit=1: active
12	Lamp fault	Bit=1: active
13	Visor no signal	Bit=1: active
14	Mirror adj. End	Bit=1: active
15	File measval	Bit=1: active

Table 31: Bitmap “Failure”

Bit No.	Name	Comment
16	File config	Bit=1: active
17	File conditions	Bit=1: active
18	File espec	Bit=1: active
19	File cact	Bit=1: active
20	Visor com.	Bit=1: active
21	Lamp com.	Bit=1: active
22	Spectro para.	Bit=1: active
23	Eval modul com.	Bit=1: active
24	Purge air signal	Bit=1: active
25	Temp control com.	Bit=1: active
26	Temp control out of range	Bit=1: active
27	Failure eval module	Bit=1: active
28	MV failure activ	Bit=1: active
29	Reserved	Bit=1: active
30	Reserved	Bit=1: active
31	Reserved	Bit=1: active

9.3.6 Bitmap Table “Maintenance Request”

Bit No.	Name	Comment
0	Lamp performance	Bit=1: active
1	Lamp minimum parameter	Bit=1: active
2	Lamp 4Q max parameter	Bit=1: active
3	Data logging: writing data	Bit=1: active
4	Data logging: open file	Bit=1: active
5	Temp. Extern	Bit=1: active
6	Flashcard missing	Bit=1: active
7	Logbook error	Bit=1: active
8	IO com.	Bit=1: active
9	IO error	Bit=1: active
10	Spectro no answer	Bit=1: active
11	Check Cycle span drift	Bit=1: active
12	Check Cycle zero drift	Bit=1: active
13	Check Cycle wavelength drift	Bit=1: active
14	Check Cycle peak position	Bit=1: active
15	Check Cycle peak width	Bit=1: active

Table 32: Bitmap “Maintenance Request”

Bit No.	Name	Comment
16	Check Cycle cell empty	Bit=1: active
17	Temp control voltage low	Bit=1: active
18	Temp control lamp fan	Bit=1: active
19	Temp control optic fan	Bit=1: active
20	Temp control spectro fan	Bit=1: active
21	Temp control electronic temp	Bit=1: active
22	Temp control spectro temp	Bit=1: active
23	Lamp performance limit	Bit=1: active
24	Probe message	Bit=1: active
25	Reserved	Bit=1: active
26	Reserved	Bit=1: active
27	Reserved	Bit=1: active
28	Reserved	Bit=1: active
29	Reserved	Bit=1: active
30	Reserved	Bit=1: active
31	Reserved	Bit=1: active

9.3.7 Bitmap Table Function “Check” and “Out of Specification”

The “Function Check” and “Out of Specification” is currently not defined

Bit No.	Name	Comment
0 -31	not specified	Bit=1: active

Table 33: Bitmap Table for “Function Check” and “Out of Specification”

9.3.8 Bitmap Table “Extended”

Additional functions, such as alarm functions are listed in Bitmap Table.

Bit No.	Name	Comment
0	Alarm purge air	Bit=1: active
1	Alarm optic housing temperature	Bit=1: active;
2	Alarm lamp current	Bit=1: active;
3	Alarm lamp integration	Bit=1: active;
4	Alarm pressure (pressure < 800 hPa or pressure > 1300 hPa)	Bit=1: active
5-31	Reserved	

Table 34: Bitmap Table for extended functions

9.3.9 Table “Operating States”

Value	Operating state
0	not defined
1	Initialisation
2	Measuring
3	Maintenance
4	RCycle
5	Check cycle
6	ZeroAdjust
7	Alignment
8	Boxmeasuring
9	Restart
10	Reserved
11	Reserved
12	Reserved
13	Reserved
14	Reserved
15	Reserved
16	Reserved
17	Reserved
18	Reserved
19	Reserved
20	Reserved

Table 35: Table “Operating states”

9.4 Dimensions

Fig. 39: GM32-sender/receiver unit (all dimensions in mm)

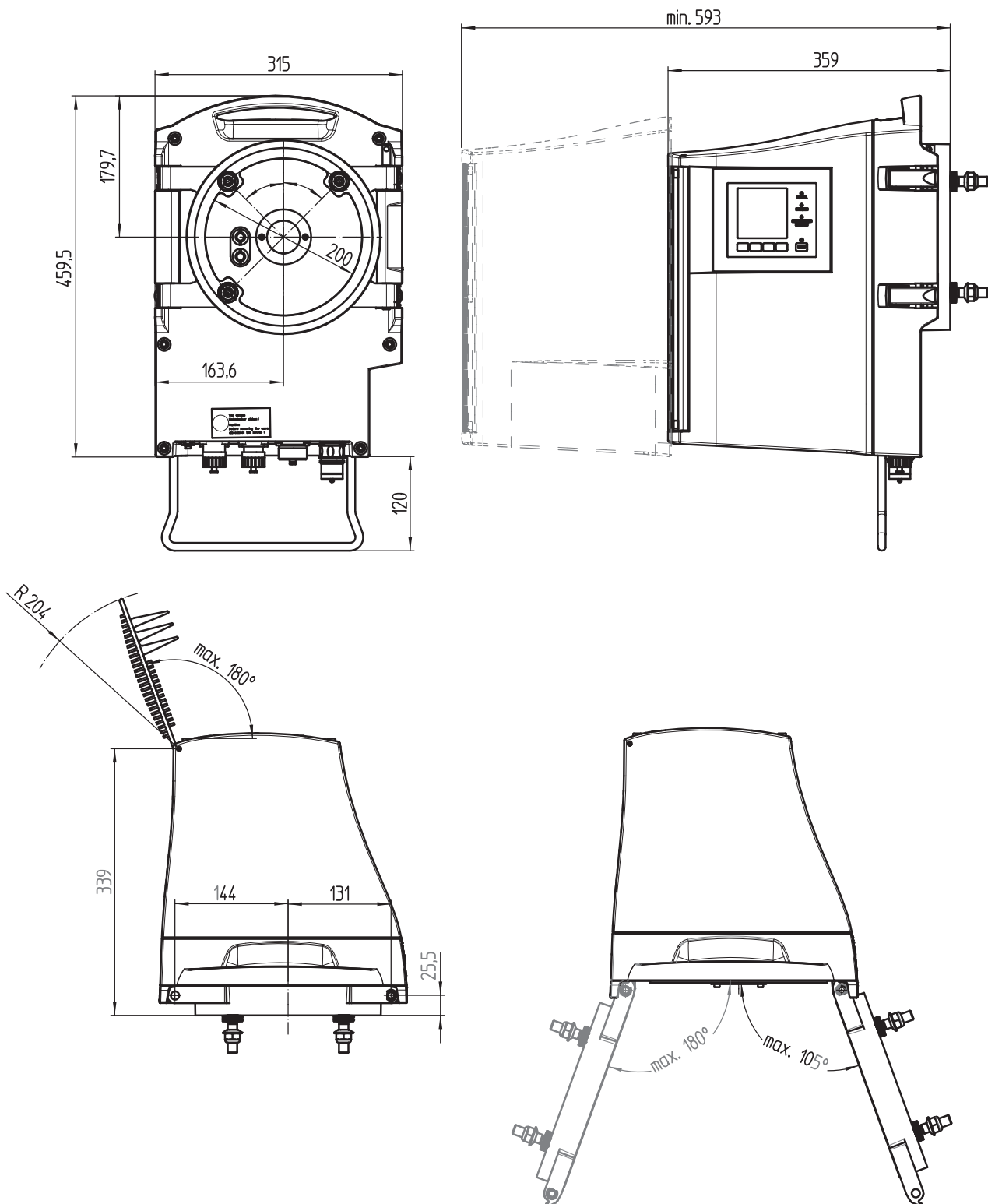

+i The sender/receiver unit housing can be swiveled to the left or right of the device flange (max. 180°/105°).

Fig. 40: GM32 measuring probe, type GMP – open measuring probe (all dimensions in mm)

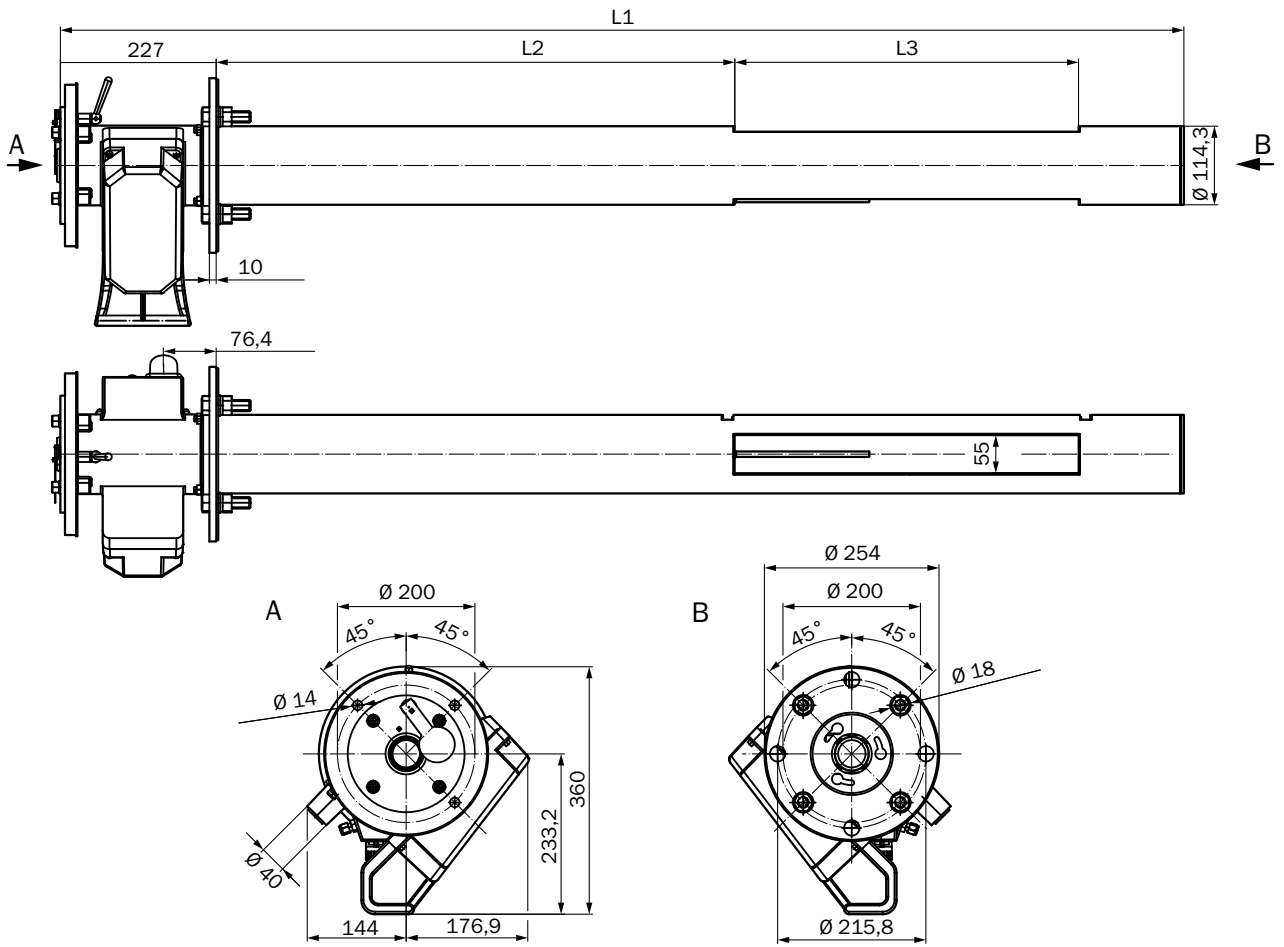

GMP measuring probes		Measuring gap L3 (active measuring path)						
		250	500	750	1.000	1.250	1.500	1.750
Nominal probe length	L1	L2						
	900	935	296	--	--	--	--	--
1.500	1.644	1.004,5	754,5	504,5	254,5	--	--	--
2.000	2.128	1.489	1.239	989	739	239	239	--
2.500	2.628	1.988	1.738	1.488	1.238	988	738	488

Application-specific lengths on request

Table 36: Probe lengths GMP measuring probes (all dimensions in mm)

Fig. 41: GM32 measuring probe, type GPP – gas diffusion probe (all dimensions in mm)

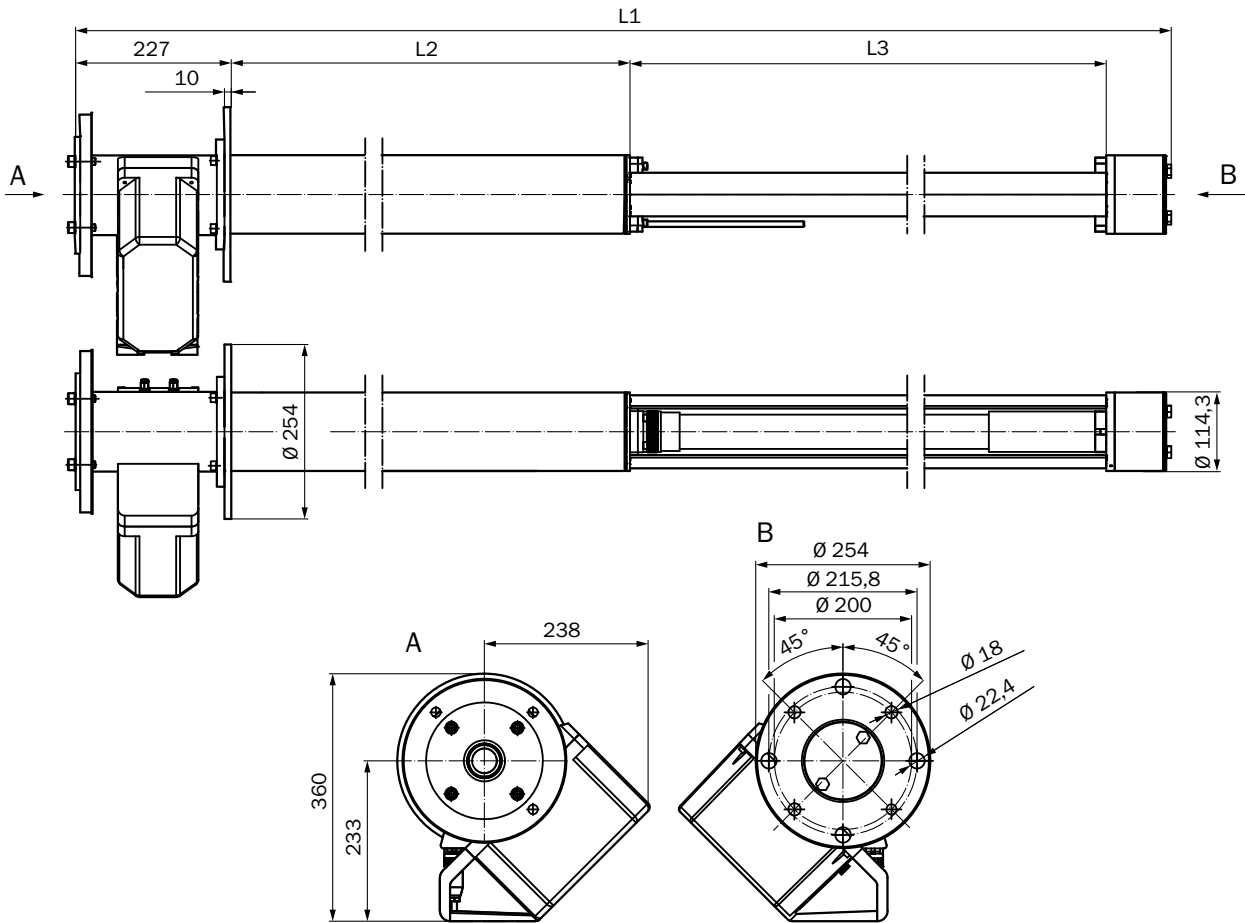

GPP measuring probes		Measuring gap L3 (active measuring path)				
		227	477	727	977	
Nominal probe length	L1	L2				
	900	914	353	103	--	--
	1,500	1,624	1,063	813	563	313
	2,000	2,108	1,547	1,297	1,047	797
	2,500	2,608	2,047	1,797	1,547	1,297
All dimensions in mm						

Application-specific lengths on request

Table 37: Probe lengths GPP measuring probes (all dimensions in mm)

Fig. 42: Mounting flange DN125 (all dimensions in mm)

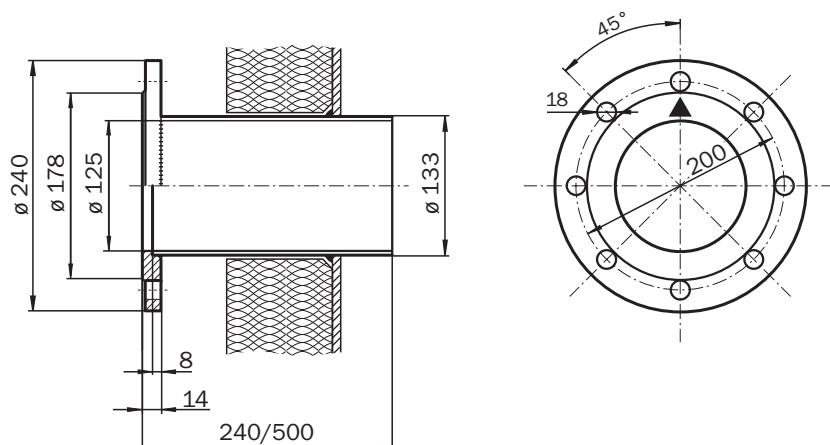

Fig. 43: Connection unit (all dimensions in mm)

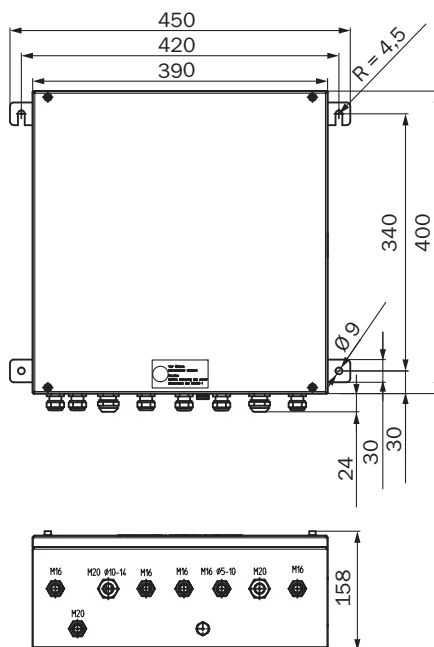
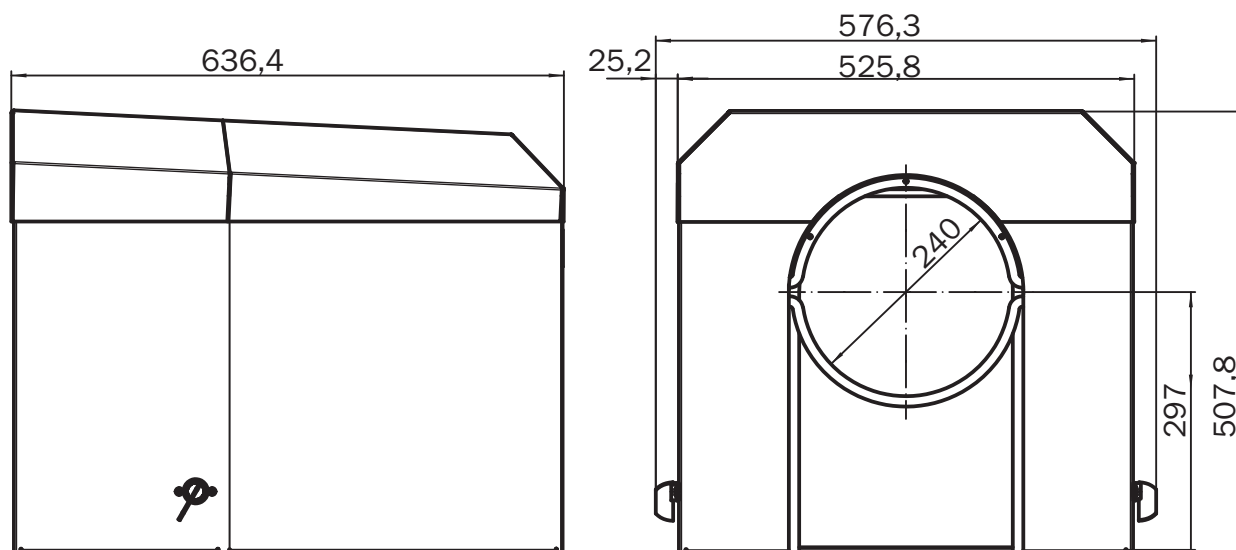

Fig. 44: Weatherproof cover for sender/receiver unit (all dimensions in mm)



8029938/ZVF9/V2-1/2019-04

www.addresses.endress.com
