

Operating Instructions

MCS300P

Multicomponent Analysis System

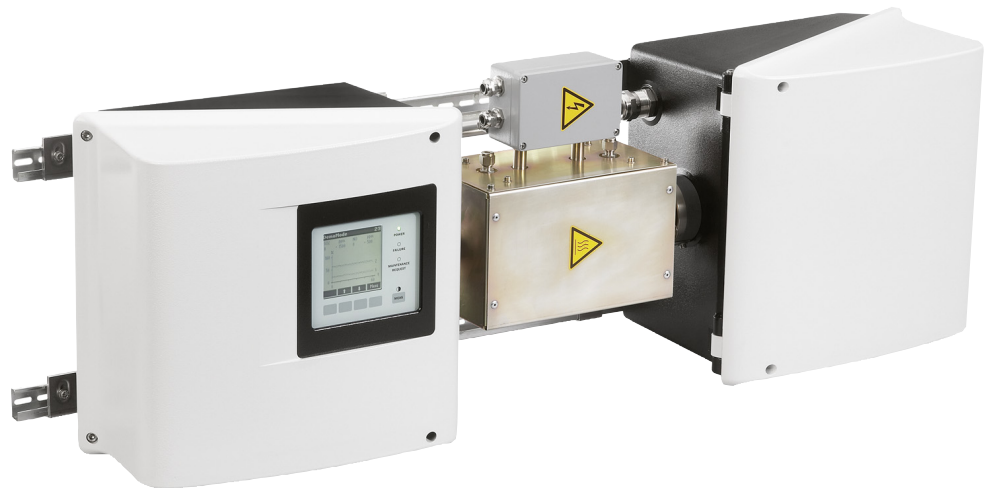

Described product

Product name: MCS300P

Manufacturer

Endress+Hauser SICK GmbH+Co. KG
Bergener Ring 27
01458 Ottendorf-Okrilla
Deutschland

Legal information

This work is protected by copyright. Any rights derived from the copyright shall be reserved for Endress+Hauser SICK GmbH+Co. KG. Reproduction of this document or parts of this document is only permissible within the limits of the legal determination of Copyright Law. Any modification, abridgment or translation of this document is prohibited without the express written permission of Endress+Hauser SICK GmbH+Co. KG. The trademarks stated in this document are the property of their respective owner.

© Endress+Hauser SICK GmbH+Co. KG. All rights reserved.

Original document

This document is an original document of Endress+Hauser SICK GmbH+Co. KG.



Contents

1	Important information	6
1.1	Main safety information.....	6
1.2	Intended use	6
1.2.1	Purpose of the device.....	6
1.2.2	Installation location	6
1.3	Responsibility of user.....	7
1.4	Additional documentation/information.....	8
2	Product description	9
2.1	Product identification.....	9
2.2	Features of the MCS300P	9
2.2.1	Internal temperature monitor	10
2.3	Method of operation	11
2.4	Interfaces	11
2.5	Remote control/data transfer	11
2.5.1	Ethernet.....	11
2.5.2	Modbus	11
2.5.3	OPC (option)	11
2.6	SOPAS ET (PC program)	12
3	Installation.....	13
3.1	Important information for installation.....	13
3.2	Overview of assembly steps	14
3.2.1	Material required	14
3.2.2	Overview of assembly steps	14
3.3	Assembly	15
3.3.1	Fitting the G-type rails	15
3.3.2	Fastening the MCS300P on the G-type rails	15
3.3.3	Connecting the tubes of the measured and test medium	16
3.3.4	Connecting the enclosure purging (if desired)	16
3.4	Electrical installation.....	17
3.4.1	Signal connections in the sender unit	18
3.4.1.1	Opening the sender unit	19
3.4.1.2	Connecting signal lines.....	19
3.4.1.3	Connecting thermostatic-controlled subassemblies	19
3.4.1.4	Preparing the main power supply.....	20
3.4.1.5	Closing the sender unit.....	20
3.4.2	Connecting the potential equalization	21
3.4.3	Connecting Ethernet	21
4	Operation	22
4.1	Operating and display elements.....	22
4.1.1	Button assignment	23

4.2	Status and classification	24
4.2.1	Status (operating state)	24
4.2.2	Classification, LEDs.....	24
4.3	Starting-up the MCS300P	25
4.4	Measuring screens	26
4.4.1	“List” Measuring screen.....	26
4.4.2	“Bar graph” Measuring screen	26
4.4.3	“Line graph” Measuring screen	27
4.4.4	Password	27
5	Menus.....	28
5.1	Menu tree.....	28
5.2	Main menu	29
5.3	Maintenance	29
5.3.1	Maintenance/maintenance signal	29
5.3.2	Maintenance/operating states	30
5.3.2.1	System stop	30
5.3.3	Maintenance/Hardware Reset	31
5.3.4	Maintenance/Reset Messages.....	31
5.4	Adjustment.....	32
5.4.1	Adjustment/manual	32
5.4.1.1	Zero point and span point.....	32
5.4.2	Adjustment/automatic	33
5.4.3	Adjustment/Parameter	33
5.4.3.1	Concentration	34
5.4.3.2	Factors	35
5.4.3.3	Start times	36
5.5	Diagnosis	36
5.5.1	Diagnosis/check values.....	37
5.5.1.1	Zero drift	37
5.5.1.2	Reference energy.....	37
5.5.1.3	Amplification	37
5.5.1.4	Intensity.....	38
5.5.2	Diagnosis/temperatures.....	38
5.5.3	Diagnosis/system info	38
5.5.4	Diagnosis/error messages and Diag button	38
5.6	Parameter setting.....	39
5.6.1	Parameter settings/display	39
5.6.1.1	Scale.....	40
5.6.1.2	Timeline.....	40
5.6.2	Parameter/reset.....	41
6	Shutdown.....	42
6.1	Shutdown	42
6.2	Disposal	43

7	Maintenance.....	44
7.1	Spare parts.....	44
7.1.1	Recommended spare parts	44
7.2	Maintenance plan	44
7.2.1	Before commencing maintenance work	44
7.2.2	Observe before opening the device enclosure	45
7.2.3	Visual inspection.....	45
7.2.4	Zero and test gas feed	45
7.2.5	Checking/replacing the desiccant cartridge	46
7.2.6	Removing/installing the cell	48
8	Clearing malfunctions.....	52
8.1	If the MCS300P does not function at all	52
8.2	When measured values are obviously incorrect	52
8.3	Malfunction messages.....	52
8.4	Fuses	53
8.4.1	LEDs on circuit board	54
8.5	Error messages and possible causes	55
9	Specifications.....	59
9.1	Compliances.....	59
9.2	Technical Data	59
9.2.1	Dimensions and drilling diagram	60
9.2.2	Measured value recording.....	64
9.2.3	Enclosure specification	64
9.2.4	Ambient conditions	64
9.2.5	Interfaces and protocols	65
9.2.6	Electrical connection	65
9.2.7	Purge air (optional)	65

1 Important information

1.1 Main safety information

**CAUTION: Health risk through dangerous measured medium**

The operator is responsible for the safe handling of the measured medium.

- ▶ In addition to these Operating Instructions, follow all local laws, technical rules and company-internal operating directives applicable at the respective installation location of the MCS300P.
 - ▶ Operate the MCS300P only in adequately ventilated rooms
OR
install a suitable gas monitor.
 - ▶ Feed and drain the measured medium in a safe manner.
 - ▶ Regularly check the state of the device/module seals.
 - ▶ Only open the device when well ventilated, especially when a leak of a device component is suspected.
-

1.2 Intended use

1.2.1 Purpose of the device

The MCS300P measuring equipment serves for process monitoring of gases and liquids and for raw gas monitoring in combustion plants.

The measured medium is extracted at a sampling point and led through the cell of the MCS300P (extractive measurement).

1.2.2 Installation location

MCS300P is intended for indoor operation.

**WARNING: Risk of explosion in potentially explosive atmospheres**

- ▶ Do not use the MCS300P in potentially explosive atmospheres.
-

1.3 Responsibility of user

Designated users

The MCS300P should only be installed and operated by skilled technicians who, based on their technical training and knowledge as well as knowledge of the relevant regulations, can assess the tasks given and recognize the hazards involved.

Correct use



- This Manual presumes that the MCS300P has been delivered as specified during project planning and the relevant delivery state of the MCS300P (→ delivered System Documentation).
 - ▶ If you are not sure whether the MCS300P complies with the planned state or the delivered System Documentation:
Please contact Endress+Hauser Customer Service.
-

- ▶ Use the device only as described in these Operating Instructions.
The manufacturer assumes no responsibility for any other use.
- ▶ Perform the specified maintenance work.
- ▶ Do not remove, add or modify any components to or on the device unless described and specified in the official manufacturer information. Otherwise:
 - Any warranty by the manufacturer becomes void.
 - The device could become dangerous.

Special local conditions

- ▶ Follow all local laws, regulations and company-internal operating directives applicable at the installation location.

Retention of documents

These Operating Instructions:

- ▶ Must be kept available for reference.
- ▶ Must be passed on to new owners.

1.4 Additional documentation/information

- ▶ Observe the supplied documents.

Additional instructions

The following documents are applicable in addition to these Operating Instructions:

- Operating Instructions of the cell used
- “Modular I/O System” Operating Instructions

System Documentation

Some parameter settings, components and characteristics depend on the individual device configuration. The delivery state is documented in the System Documentation provided.

The individual characteristics include for example:

- Measured components and measuring ranges
- Additional equipment (options)
- Basic settings

2 Product description

2.1 Product identification

Product name:	MCS300P
Manufacturer:	Endress+Hauser SICK GmbH+Co. KG Bergener Ring 27 · 01458 Ottendorf-Okrilla · Germany
Production location:	Endress+Hauser SICK GmbH+Co. KG Rengoldshauser Str. 17A · 88662 Überlingen · Germany

The type plate is located on the sender unit next to the cell flange.

2.2 Features of the MCS300P



The MCS300P has customized equipment.

- For the equipment fitted on your MCS300P, see the System Documentation provided.

Fig. 1: MCS300P (shown here with gas cell PGK)

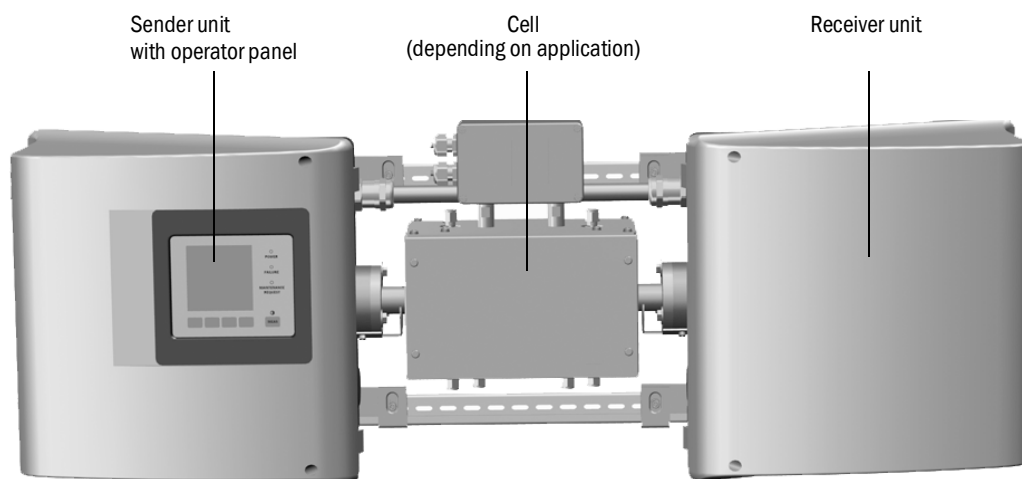

Function

The MCS300P serves for process monitoring of gases and liquids as well as for raw gas monitoring in combustion plants.

The measured medium is extracted at a sampling point and led through the cell of the MCS300P (extractive measurement).

Photometer

Spectral acquisition of gas concentrations: Non-dispersive photometer with interference and optional gas filters.

Gas components and measured values

Number of gas components: 6 plus O₂ simultaneously.

Correction of cross-sensitivity values: Max. 6.

Internal computation of measured values (depending on parameter settings): Cross-sensitivity compensation, scaling (pressure, temperature), conversion to “dry flue gas”.

Measuring range switch-over and sampling points

Number of measuring ranges: 2 measuring ranges per component.

Number of sampling points: Max. 8.

Cells

The intended cell has been fitted according to the preceding project planning (→ System Documentation provided).

External signals and sensors

External analog and digital signals can be read in.

O₂ concentration (zirconium oxide sensor), sample gas pressure and sample gas temperature are acquired via external sensors, their signals fed to the MCS300P and computed there.

Enclosure purging

The enclosures of the MCS300P can be purged with inert gas.

Internal temperature controllers

2 internal temperature controllers to monitor thermostatically controlled subassemblies (cell, liquid preheater or sample gas line).

2.2.1 Internal temperature monitor

2 internal temperature controllers to monitor thermostatically controlled subassemblies (cell, liquid preheater or sample gas line).

2.3 Method of operation

Operating states

The actual operating state is displayed on the operator panel and output via status signals. Error messages are shown on the display and recorded in a logbook (SOPAS ET).



For more information concerning the operating states, see [“Status and classification”](#), page 24.

Sequence control programs

Various sequence control programs can be started via the operator panel.

Typical sequence control programs (depending on parameter settings) are:

- Adjustment with test medium
- Adjustment with internal adjustment standard (optical filter, option)



For the parameterized sequence control programs, see the System Documentation provided.

2.4 Interfaces

- Analog and digital interfaces (depending on equipment).
- Ethernet

2.5 Remote control/data transfer

2.5.1 Ethernet

Protocol:

- Modbus TCP/IP
- OPC.

2.5.2 Modbus

Modbus® is a communication standard for digital controls to connect a »Master« device with several »Slave« devices. The Modbus protocol defines the communication commands only but not their electronic transfer; therefore it can be used with different digital interfaces (for MCS300P: Ethernet).



For more information on the Modbus → Technical Information of MCS300P

2.5.3 OPC (option)

OPC is a standardized software interface that allows to exchange data between different applications.

The SICK OPC server (part of SOPAS ET) is required.

System bus: Ethernet.



For more information on the OPC → Technical Information of MCS300P

2.6 SOPAS ET (PC program)

SOPAS ET can be used to set the MCS300P parameters and provides access to the MCS300P logbook.

SOPAS ET runs on an external PC connected via the Ethernet interface to the MCS300P (see [“Connecting Ethernet”, page 21](#)).



More information on SOPAS ET:
→ Technical Information MCS300P
→ SOPAS ET Help menu

3 Installation

3.1 Important information for installation

**CAUTION: Health risk through dangerous measured medium**

The operator is responsible for the safe handling of the measured medium.

- ▶ In addition to these Operating Instructions, follow all local laws, technical rules and company-internal operating directives applicable at the respective installation location of the MCS300P.
- ▶ Operate the MCS300P only in adequately ventilated rooms
OR
install a suitable gas monitor.
- ▶ Feed and drain the measured medium in a safe manner.
- ▶ Regularly check the state of the device/module seals.
- ▶ Only open the device when well ventilated, especially when a leak of a device component is suspected.



This Manual presumes that the MCS300P has been installed as specified during project planning and the relevant delivery state of the MCS300P (→ delivered System Documentation).

- ▶ If you are not sure whether the MCS300P complies with the planned state or the delivered System Documentation:
Please contact Endress+Hauser Customer Service.
- ▶ If you intend to make changes to the MCS300P:
Please contact Endress+Hauser Customer Service.

The operator is responsible for:

- ▶ Determining and preparing the sampling point (e.g., determining a representative sampling point).
- ▶ Feeding and discharging the measured medium.
- ▶ Supplying zero and test gases.

**CAUTION: Risk of injury through incorrect lifting and carrying the equipment**

Injuries can occur due to the weight and projecting enclosure parts when the equipment tips over or drops. Observe the following information to avoid such accidents:

- ▶ Do not use protruding parts on the enclosure to carry the equipment (apart from the wall fixture or carrying grips).
- ▶ Never lift the equipment using the open equipment door.
- ▶ Consider the equipment weight before lifting.
- ▶ Observe the regulations for protective clothing (e.g., safety shoes, non-slip gloves)
- ▶ Grip underneath the equipment when possible to carry it safely.
- ▶ Use a hoist or transport equipment as an option.
- ▶ Use the help of a second person when necessary.
- ▶ Secure the equipment during transport.
- ▶ Before transporting, ensure obstacles that could cause falls or collisions are cleared away.

3.2 Overview of assembly steps

3.2.1 Material required

Assembly material	Part No./reference	Required for
Dowels / screws M5	----	Assembly of G-type rails
El. supply line	see “Preparing the main power supply”, page 20	Analyzer power connection
El. lines for signals	----	Connection of signal lines
Hose/tube for measured medium	see Operating Instructions of the cell	Measured medium feed and drain line
Purge air supply	see Operating Instructions of the cell	Cells with purge compartments
Ethernet cable (RJ45 plug on one side and M12 plug on MCS300P side)	2 m: 6034414 5 m: 6034415 10 m: 6030928	Ethernet connection
Coupling 2 x RJ45 socket	6037082	Connection between two Ethernet lines

Tool	Part No./reference	Required for
4 mm Allen key	----	Retaining bracket
5 mm Allen key	----	MCS300P cover

3.2.2 Overview of assembly steps

Assembly step	Remark/reference
Determining the installation location	As close as possible to the sampling point. Fitting position according to system documentation.
Fitting the G-type rails	see “Fitting the G-type rails”, page 15
Attaching the analyzer to the G-type rails	see “Fastening the MCS300P on the G-type rails”, page 15
Connecting the measured medium feed and drain lines	see “Connecting the tubes of the measured and test medium”, page 16
Connecting the main power supply	see “Preparing the main power supply”, page 20
Connecting signal lines	see “Connecting signal lines”, page 19

3.3 Assembly



CAUTION: Accident risk through inadequate fastening of the device

- ▶ Consider the device weight specifications when planning the mounting supports.
- ▶ Check the load capacity/condition of the wall/rack on/in which the device is to be installed.

3.3.1 Fitting the G-type rails



NOTICE:

MCS300P The MCS300P can twist when lifted, especially with long cells.

- ▶ Use 2 persons to carefully lift the MCS300P.
- ▶ Avoid twisting or bending.



NOTICE:

▶ Install the MCS300P in the position specified during project planning for the MCS300P.

- 1 Unscrew the G-type rails from the MCS300P.
- 2 Fasten the G-type rails to the wall or installation plate (fitting direction and drilling diagram, see [“Technical Data”, page 59](#) cont.).
 - ▶ Observe the carrying capacity of approx. 30 kg (plus cell).
 - ▶ Position groove (see [“Mounting position \(example: horizontal installation\)”](#)) for mounting the MCS300P at the bottom.

3.3.2 Fastening the MCS300P on the G-type rails

Fig. 2: Mounting position (example: horizontal installation)

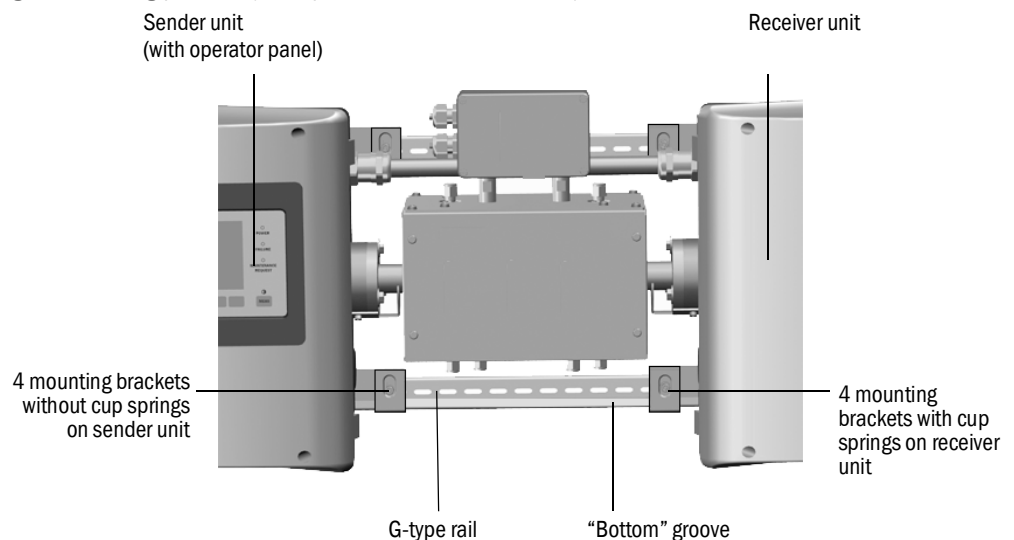

- 1 Lift the MCS300P carefully and slot it into the G-type rails.
 - a) For horizontal installation:
 - Fit the sender unit on the left side.
 - b) For vertical installation:
 - Fit the sender unit with the operator panel at the top.
- 2 Screw the sender unit tight (4 mounting brackets).
- 3 Screw the receiver unit on loosely so that enough clearance remains for temperature equalization (4 mounting brackets and cup springs).

3.3.3 Connecting the tubes of the measured and test medium



The operator is responsible for correct connection of the tubes of the measured medium as well as for the supply with zero and test medium.
Information → Operating Instructions of the connected cell.

3.3.4 Connecting the enclosure purging (if desired)

Fig. 3: Connections for enclosure purging

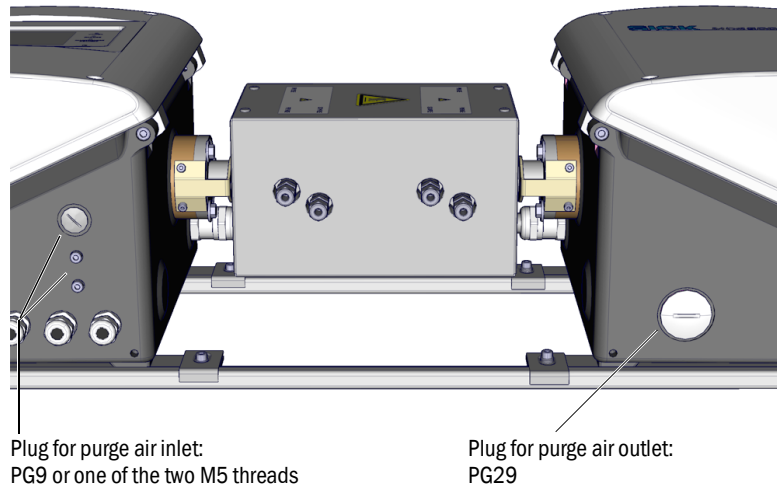

- ▶ Connect the enclosure purging at the corresponding enclosure ducts.
 - Recommended purging direction: From sender unit to receiver unit.
 - Max. throughput: 5 l/h.
 - Use suitable inert gas (e.g.: Instrument air, specification → Technical Data).

3.4 Electrical installation

**CAUTION: Hazards through electric voltages**

- ▶ Only let the work described in the following be carried out by skilled electricians who can recognize potential risks.
- ▶ Before opening the enclosure: Separate all connectors of the MCS300P from the main power supply.

When a removable power cable is used, electrical accidents can occur when the specifications are not fully observed.

- ▶ Always observe the exact specifications in the Operating Instructions (Technical Data Section) when replacing a removable power cable.

**NOTICE: The M screw connections must be screwed gas-tight**

If the M screw connections of the ducts of the electric lines are not gas-tight, gas can penetrate the enclosure, falsify the measurement and cause corrosion.

- ▶ Only use lines with suitable outer diameters (see [“Horizontal installation”, page 60](#)).

**NOTICE: Observe the system documentation during installation**

- ▶ Observe the terminal assignment (→ system documentation).

**CAUTION: Device damage through incorrect or missing grounding**

During installation and maintenance work, it must be ensured that the protective grounding to the devices and/or lines involved is effective in accordance with EN 61010-1.

3.4.1 Signal connections in the sender unit

Fig. 4: Electrical connections in the sender unit main power supply (see "Preparing the main power supply", page 20)

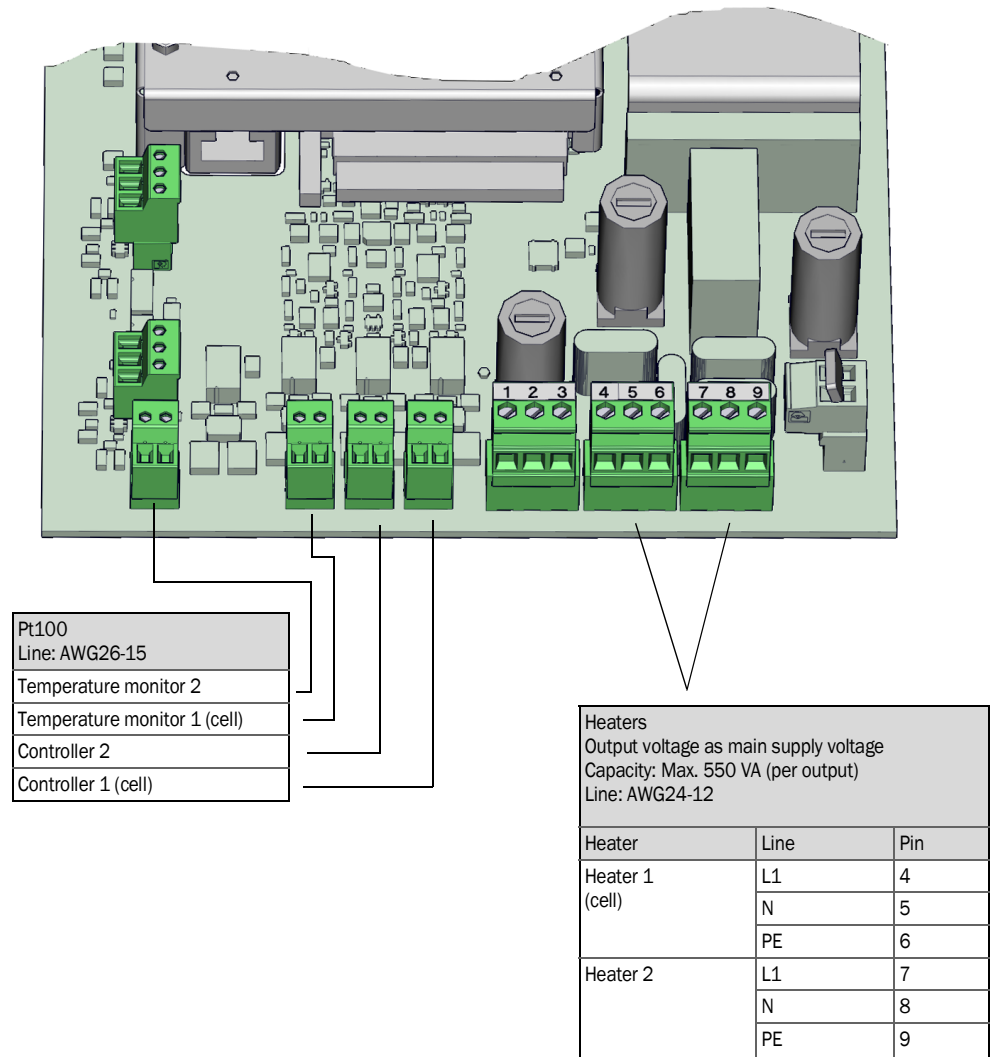

3.4.1.1 Opening the sender unit



WARNING: Damage to eyes by radiation

Depending on the lamp type, eyes can be damaged by radiation.

- ▶ Before opening the cover of the sender unit: Switch off the MCS300P at the external main power switch.



WARNING: Hot lamp

Components in the area of the lamp can be hot.

- ▶ Do not touch components in the area of the lamp; allow to cool down first.



Also observe the general information on opening the enclosure (see [“Observe before opening the device enclosure”, page 45](#)).

- 1 Loosen 4 screws (5 mm Allen key).
- 2 Open the cover.

3.4.1.2 Connecting signal lines

Fig. 5: Position of I/O interfaces in the sender unit

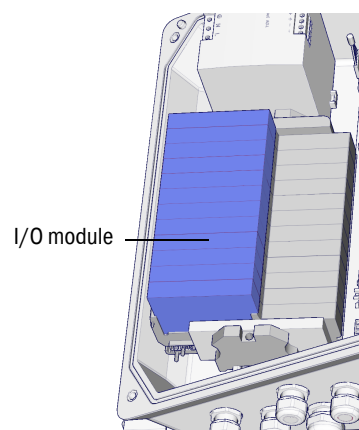

- ▶ Route the data lines through the M screw connection and connect to the I/O modules (terminal assignment → System Documentation provided).



- Information on the I/O modules → Operating Instructions “Modular I/O System”.

3.4.1.3 Connecting thermostatic-controlled subassemblies

- ▶ Route the lines through the M screw connection and connect the lines (see [“Preparing the main power supply”, page 20](#)).

3.4.1.4 Preparing the main power supply

- ▶ Provide separate external main power switches which can be disconnected on all connectors and fuses in the proximity of the MCS300P (max. power input of the MCS300P → Technical data).
Make sure the disconnecter switch is easily accessible.
- 3 Check the main supply voltage specified in the System Documentation.



NOTICE: Fuse values depend on the power voltage

If the power voltage available locally is not identical with the power voltage specified in the System Documentation or there are any doubts concerning the power voltage set:

- ▶ Check the fuse values in the MCS300P (see “Fuses”, page 53).

- 4 Route the electric lines through the M screw connections and connect the lines.

Fig. 6: Connecting the main power supply

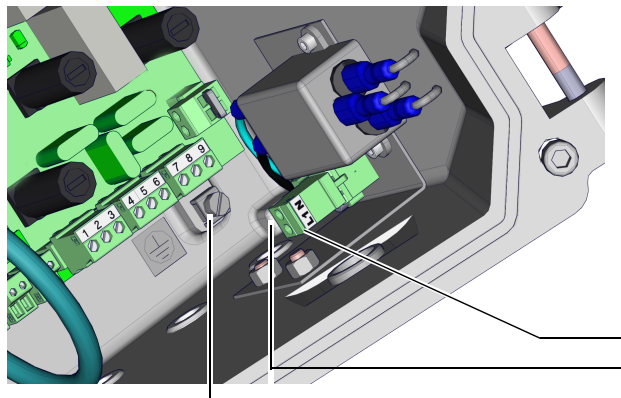

Main power supply voltage
100 .. 240 V / 50 .. 60 Hz
Line: Max. AWG14



The fuses depend on the power voltage

Line	Terminal
L1	L1
N	N
PE	G ^[1]

[1] G = enclosure ground

3.4.1.5 Closing the sender unit

- ▶ Close the sender unit and screw tightly.

3.4.2 Connecting the potential equalization

- ▶ Connect potential equalization (cable: 2.5 mm²).
(Connect additional potential equalization of the cell)

Fig. 7: Connecting the potential equalization

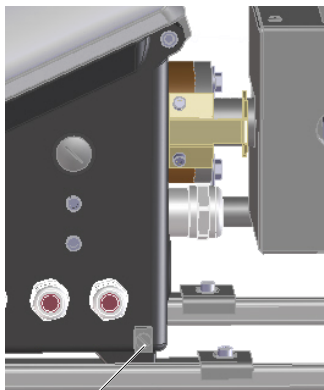

Connector for potential equalization

3.4.3 Connecting Ethernet

Fig. 8: Ethernet connection (underside of sender unit)

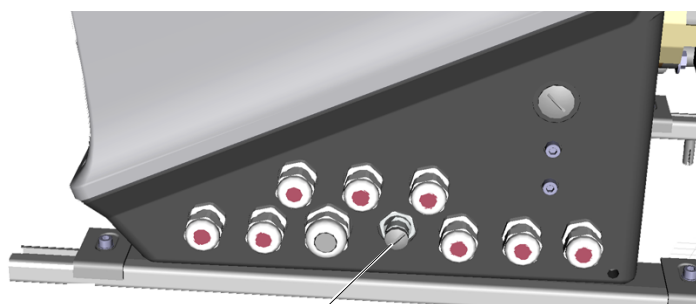

Connection: Bus system port, Ethernet, 4 poles, M12, D-coded

- ▶ Connect Ethernet to the M12 port.
Coupling for connection of a second Ethernet cable, see [“Material required”, page 14](#)

4 Operation



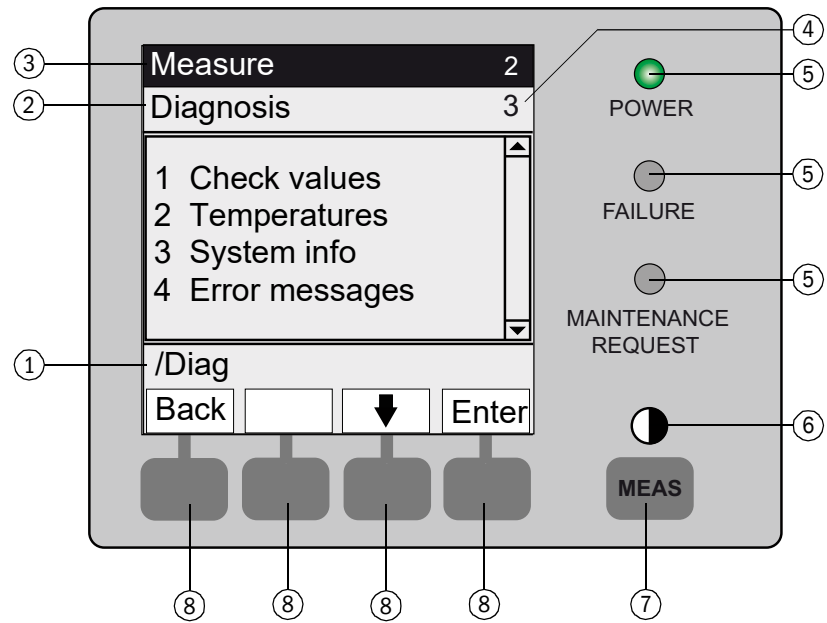

4.1 Operating and display elements

Fig. 9: Display (example: Menu "Diagnosis")



- | | |
|--|---|
| 1 Current menu branch | 5 LED (see "Classification, LEDs", page 24) |
| 2 Current menu | 6 Contrast icon (see "Button assignment", page 23) |
| 3 Status bar (see "Status (operating state)", page 24) | 7 "MEAS" button (see "Button assignment", page 23) |
| 4 Menu number | 8 Function buttons (see "Button assignment", page 23) |

4.1.1 Button assignment

Button	Significance
<MEAS> button	
<MEAS>	Back to the Measuring screen from any menu. <ul style="list-style-type: none"> - Press <Save> to store any changes made. Otherwise the changes are lost. - When the MCS300P is set to "Maintenance" (see "Classification, LEDs", page 24): Pressing the <MEAS> button does not affect the "Maintenance" state.
	In the Measuring screen: Toggle between list, bar and line representation (see "Measuring screens", page 26).
	 To set the contrast: Press the MEAS button for longer than 2 seconds.
Function buttons (menu-dependent buttons)	
<Menu>	Return to the main menu (see "Main menu", page 29). If the <Menu> button is not shown: Press <MEAS> first.
<Back>	Return to the higher level menu. Press <Save> to store any changes made. Otherwise the changes are lost.
<Enter>	Open the selected menu.
<Save>	Save changed parameters.
<Start>	Start the displayed action.
<Set>	Set the value.
	Move/scroll downward.
	Move/scroll upward. When numbers are entered: Next higher number.
	Moves to the right in the line.
<Diag>	<i>Diag</i> is shown only when there is a message. To display the message: Press this button. More information on diagnosis, see "Diagnosis/error messages and Diag button", page 38. List of error messages, see "Error messages and possible causes", page 55.

4.2 Status and classification

4.2.1 Status (operating state)

The respective operating state (e.g., measuring, heating, etc.) is displayed in the top line of the operator panel.

4.2.2 Classification, LEDs

The classification (error status) is indicated by LEDs on the operator panel and recorded in the logbook (SOPAS ET).

Classification	LED	Significance	Measuring screen	Analog outputs ^[1]	Status signal ^{[2],[3]}
<i>Maintenance</i>		The MCS300P is switched to " <i>Maintenance</i> " via the menu or program. The status bar shows: " <i>Status: Maintenance</i> "	Actual	Frozen ^[4]	According to setting
<i>Uncertain</i>		The <i>uncertain</i> measured value (e.g., outside calibration range) <i>blinks</i> . To view the cause: Press the < <i>Diag</i> > button.	Actual	Actual	According to setting
<i>Maintenance request</i>	<i>Yellow</i>	Irregularities (e.g., deviation from check cycle too high) that require a review of the cause. To view the cause: Press the < <i>Diag</i> > button.	Actual	Actual	According to setting
<i>Failure</i>	<i>Red</i>	Device failure (e.g., lamp failed) To view the cause: Press the < <i>Diag</i> > button.	Frozen ^[4]	Frozen ^[4]	According to setting

[1] Typical default (→ System Documentation).

[2] Option (→ System Documentation).

[3] See SOPAS ET in the "Digital outputs" menu.

[4] The last valid measured value is retained.

4.3 Starting-up the MCS300P

- 1 The MCS300P starts automatically when the power supply is switched on.
- 2 The green “POWER” LED on the MCS300P display will signal that supply voltage is present.
- 3 The logo will appear on the screen.
- 4 The Measuring screen will then be displayed (see “Display (example: Menu “Diagnosis””, page 22)
- 5 Until the measuring system reaches its measuring operating state (e.g., the operating temperature has not yet been reached):
 - Only the green “POWER” status LED will light.
 - Display will read: “Status: Heating”
 - Classification “Uncertain” (all measured values blink).
- 6 Measuring operating state reached:
 - Only the green “POWER” status LED will light.
 - Display will read: “Status: Measuring” (see “Display (example: Menu “Diagnosis””, page 22).
 - No measured value blinks (If a measured value blinks: Measured value invalid, see “Malfunction messages”, page 52).

4.4 Measuring screens

Measuring screens:

“List” (default)

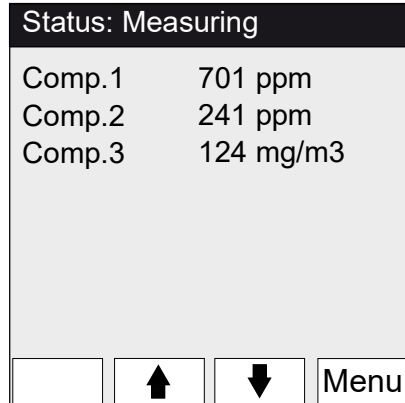

Bar graph

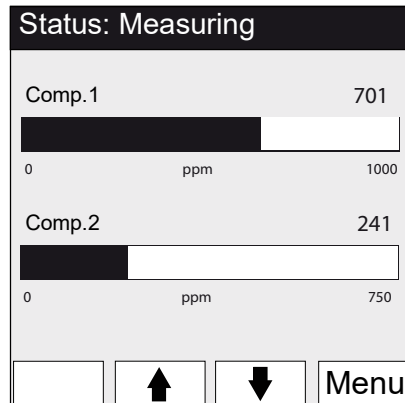

Line graph

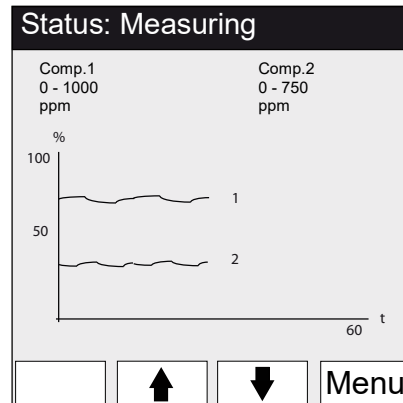

► To toggle between the Measuring screens: <MEAS> button

4.4.1 “List” Measuring screen

Display of measured values in tabular form.

The “List” Measuring screen is displayed:

- Automatically after the system start
- When the <MEAS> button is pressed

Update interval: 1 second (default)

4.4.2 “Bar graph” Measuring screen

Display of 2 measured values each time in bar format.

Update interval: 1 second

► Parameter settings of display ranges, see “Timeline”, page 40

4.4.3 “Line graph” Measuring screen

Display of 2 measured values each time in the time diagram.
 The y-axis is always scaled to 0 - 100% of the display range.
 (The respective display range is shown below the component)
 Line 1 = left component.
 Line 2 = right component.
 Update interval:

Time axis [min]	Update interval [sec]
6	4
15	10
30	20
60	40

► Parameter settings of display ranges, see “Timeline”, page 40

4.4.4 Password

Menus which allow changing the measuring sequence are protected with a password.
 The password is prompted automatically when such a menu is called up.



 A complete description of the password-protected menus can be found in the MCS300P “Technical Information”.

Fig. 10: Password input (example: Reset menu)

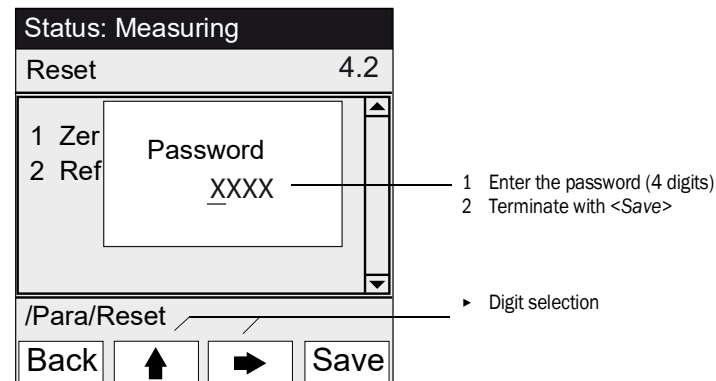

- The password contains 4 digits.
- The password is: “1234” (default)
- The password level remains valid for 30 minutes (default).

 The password and duration of validity can be changed in SOPAS ET.

5 Menus

5.1 Menu tree

Menu No.	Menu tree	Explanation
1	Maintenance	
1.1	Maintenance signal	see "Maintenance", page 29
1.2	Operating states	
1.2.1	System stop	
1.2.2	Measure	
1.2.3	Initialize	
1.3	Hardware Reset	
1.4	Reset messages	
2	Adjustment	see "Adjustment", page 32
2.1	Manual	
2.1.1	Zero point	
2.1.2	Span point	
2.2	Automatic	
2.3	Parameter	
2.3.1	Concentration	
2.3.2	Factors	
2.3.3	Start time 1-8	
2.3.4	Start time 9-16	
3	Diagnosis	see "Diagnosis", page 36
3.1	Check values	
3.1.1	Zero drift	
3.1.2	Reference energy	
3.1.3	Amplification	
3.1.4	Intensity	
3.2	Temperatures	
3.3	System info	
3.4	Error messages	
4	Parameter	see "Parameter setting", page 39
4.1	Display	
4.1.1	Scale 1 .. 8	
4.1.2	Scale 9 .. 16	
4.1.3	Timeline	
4.2	Reset	
4.2.1	Zero drift	
4.2.2	Reference energy	

5.2 Main menu

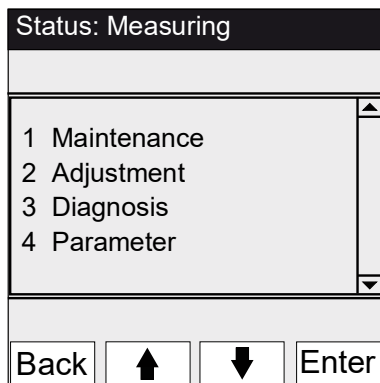

see "Maintenance", page 29
 see "Adjustment", page 32
 see "Diagnosis", page 36
 see "Parameter setting", page 39

5.3 Maintenance

Menu 1: Maintenance

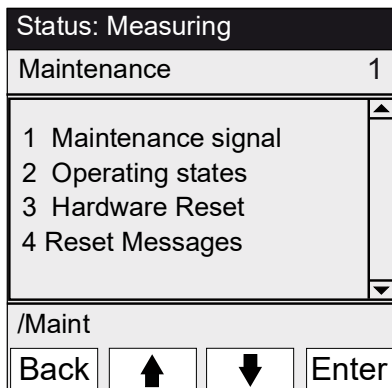

see "Maintenance/maintenance signal", page 29
 see "Maintenance/operating states", page 30
 see "Maintenance/Hardware Reset", page 31
 see "Maintenance/Reset Messages", page 31

5.3.1 Maintenance/maintenance signal

Menu 1.1: Maintenance/Maintenance sig

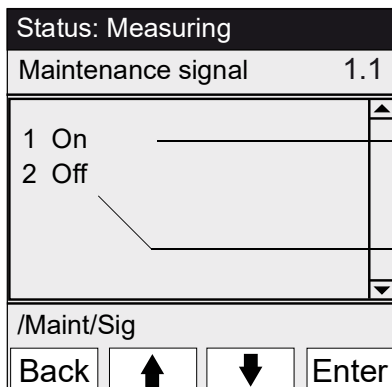

The maintenance signal is set/reset in this menu.

- ▶ The maintenance signal is set. Then:
 - Classification: "Maintenance" (see "Classification, LEDs", page 24)
 - Status bar: "Status: Maintenance".
- ▶ The maintenance signal is reset.

5.3.2 Maintenance/operating states

Menu 1.2: Maintenance/Operating states

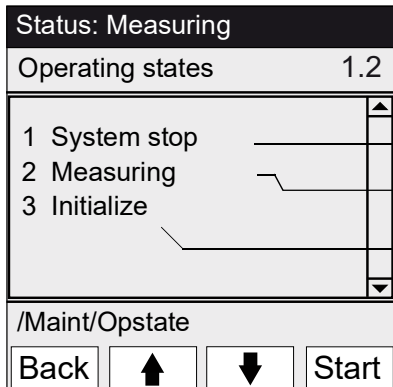

The operating states are switched on in this menu.

- ▶ System stop (see "System stop")
- ▶ Switch the MCS300P to measuring operation.
- ▶ New start (reset) of the MCS300P.

5.3.2.1 System stop

Menu 1.2.1: Maintenance/Operating states/System stop

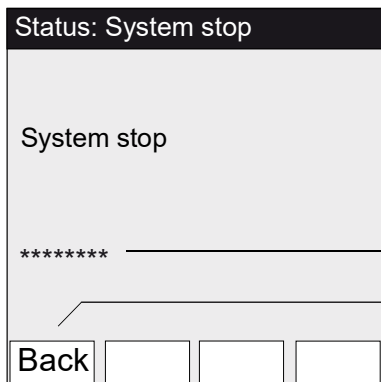

Switch off the measuring function and (If available) the gas sampling peripherals (valves, pumps). The device function is maintained (e.g., heater operation will continue).
 Operating state: "Maintenance".

- Display: Row of blinking asterisks.
- ▶ To exit the menu: Press the "Back" button.
- ▶ Then switch measuring operation on again:
 - Press "Measuring".
 - Switch the maintenance signal off (see "Maintenance/maintenance signal", page 29).

5.3.3 Maintenance/Hardware Reset

Menu 1.3: Maintenance/Hardware Reset

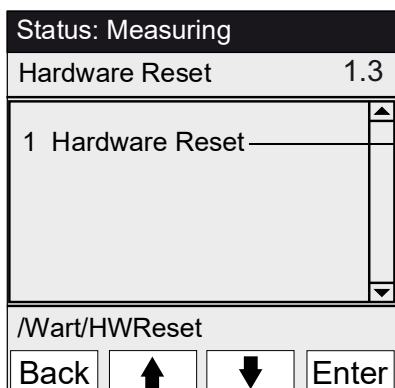

This menu starts a hardware reset (same effect as switching the main supply voltage off/on).

▶ Start hardware reset.

5.3.4 Maintenance/Reset Messages

Menu 1.4: Maintenance/Reset Messages

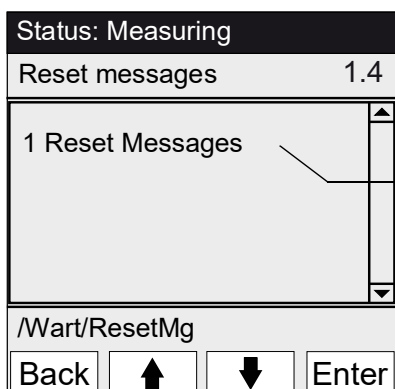

This menu resets all existing error messages. LED "MAINTENANCE REQUEST" goes off.

▶ Reset error messages.

5.4 Adjustment

Menu 2: Adjustment

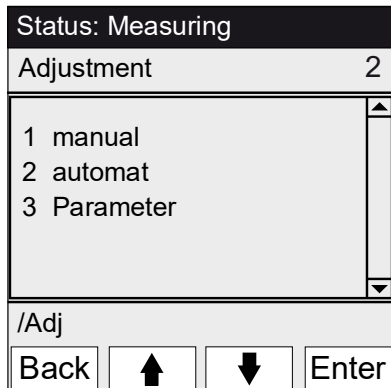

see "Adjustment/manual", page 32
 see "Adjustment/automatic", page 33
 see "Adjustment/Parameter", page 33

5.4.1 Adjustment/manual

Menu 2.1: Adjustment/manual

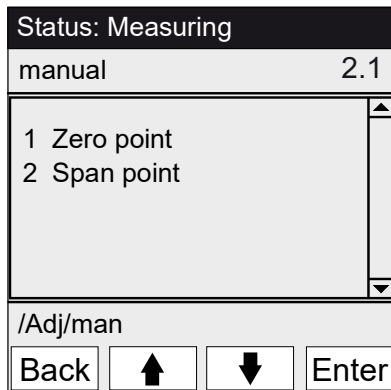

see "Zero point and span point", page 32
 see "Zero point and span point", page 32

5.4.1.1 Zero point and span point

Menu 2.1.1: Adjustment/manual/Zero point

Menu 2.1.2: Adjustment/manual/Span point

Manually adjust zero point and/or span point (recalculate the correction factor) of individual components within this menu item.

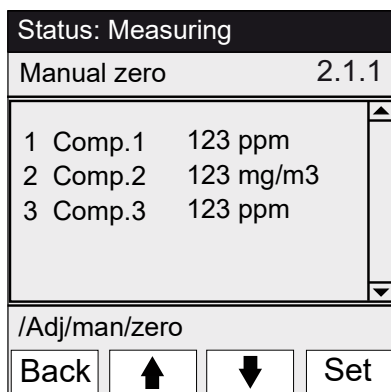

- 1 Set the maintenance signal (see "Maintenance/maintenance signal", page 29).
- 2 Lead the zero and/or reference medium into the cell ("manually").
- 3 Wait for the end of the run-in time. (If necessary, exit the menu with "Back" to review the run-in behavior in the line graph, see "Line graph Measuring screen", page 27).
- 4 Select the component.
- 5 Press "Set": The measured value is set to the nominal concentration. If the deviation is too large (parameter settings → SOPAS ET), the MCS300P switches to classification "Maintenance request" (see "Status and classification", page 24).
- 6 Press "Back" to exit the menu.
- 7 Reset the maintenance signal.

5.4.2 Adjustment/automatic

Menu 2.2: Adjustment/automatic

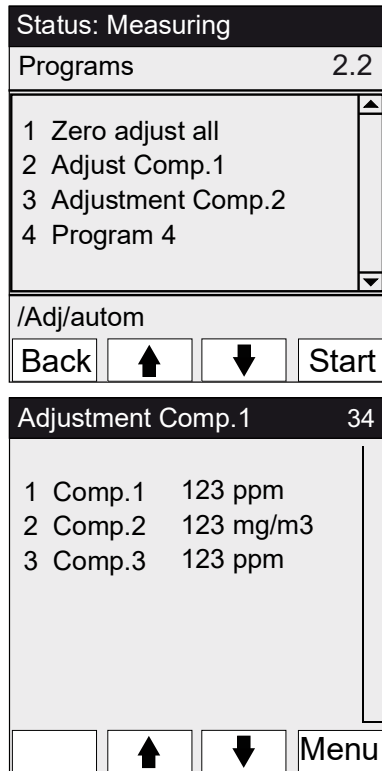

Initiate automatic adjustments within in this menu item (parameter settings → System Documentation). The sequences of these programs depend on the parameter settings of the programs (in the Figure: Examples). For typical programs, status signals are set automatically and valves for the test medium switched automatically. For devices with internal adjustment standard (see system documentation): A corresponding program appears.

- 1 To start adjustment: Select the adjustment program and press "Start".
 - 2 Operating state: "Maintenance".
 - 3 The Measuring screen is displayed (with a down counter to the end of the adjustment).
 - 4 After the end of the adjustment, the MCS300P switches back to the operating mode "Measuring" (If "Maintenance" was previously set manually: Back to "Maintenance").
- If the deviation exceeds a limit (parameter settings in SOPAS ET), the MCS300P switches to classification "Maintenance request" (see "Status and classification", page 24).

- Down counter to the end of adjustment [seconds].

5.4.3 Adjustment/Parameter

Menu 2.3: Adjustment/Parameter

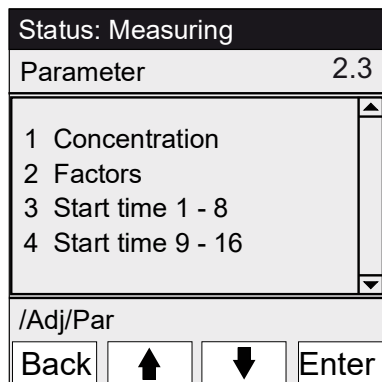

- see "Concentration", page 34
- see "Factors", page 35
- see "Start times", page 36
- see "Start times", page 36

5.4.3.1 Concentration

Menu 2.3.1: Adjustment/Parameter/Concentration

Enter the concentrations of the test media within this menu.

Status: Measuring										
Concentration	2.3.1									
<table border="1"> <tr> <td>1</td> <td>Comp.1</td> <td>500 ppm</td> </tr> <tr> <td>2</td> <td>Comp.2</td> <td>250 mg/m3</td> </tr> <tr> <td>3</td> <td>Comp.3</td> <td>500 ppm</td> </tr> </table>		1	Comp.1	500 ppm	2	Comp.2	250 mg/m3	3	Comp.3	500 ppm
1	Comp.1	500 ppm								
2	Comp.2	250 mg/m3								
3	Comp.3	500 ppm								
/Adj/Par/Conc										
Back	↑	↓	Enter							
Status: Maintenance										
Comp.1	2.3.1.1									
<u>263.5</u> ppm										
/Adj/Par/Conc/1										
Back	↑	→	Save							

5.4.3.2 Factors

Menu 2.3.2: Adjustment/Parameter/Factors

Status: Measuring		
Factors		2.3.2
1	Comp.1_M	1,1050
2	Comp.1_F	0,9874
3	Comp.2_M	1,0001
4	Comp.2_F	1,0480
/Adj/Par/Fact		
Back	↑	↓
Enter		
Status: Maintenance		
Comp.1_M		2.3.2.1
1,1050		
/Adj/Par/Fact/1		
Back	↑	→
Save		

The correction factors of the measured components are displayed and can be manually changed in this menu.

- ▶ 2 correction factors exist per component:
 - _M: Correction factor for test medium
 - _F: Correction factor for internal adjustment standard (internal optical filter) (option).

5.4.3.3 Start times

Menu 2.3.3: Adjustment/Parameter/Start time 1 - 8

Menu 2.3.4: Adjustment/Parameter/Start time 9 - 16

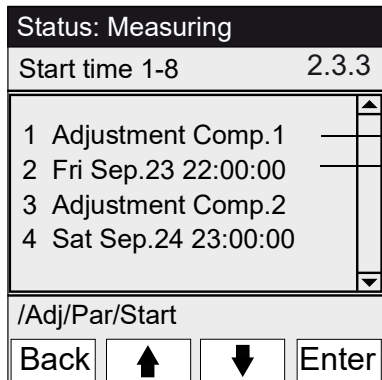

In this menu item:

- The respective next start time of a "cyclic trigger" is shown and
- the "cyclic triggers" are disabled or enabled.

Explanation: A "cyclic trigger" can be assigned to sequence control programs (→ SOPAS ET).
 "Cyclic trigger" means: The respective program is started in a fixed cycle (hours, days or weeks).

- Cyclic trigger name
- Next start time (dd.mm.yy hh:mm:ss) or "-disabled-".

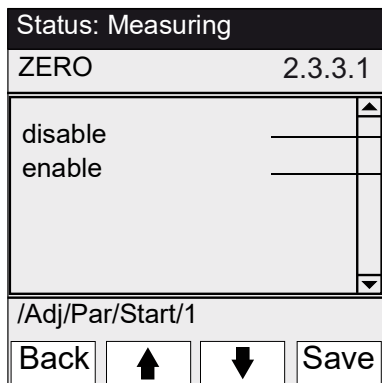

- ▶ Disable the cyclic trigger
- ▶ Enable the cyclic trigger

5.5 Diagnosis

Menu 3: Diagnosis

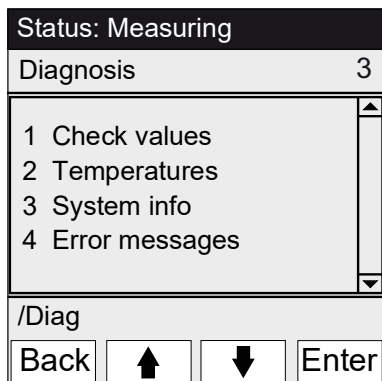

see "Diagnosis/check values", page 37
 see "Diagnosis/temperatures", page 38
 see "Diagnosis/system info", page 38
 see "Diagnosis/error messages and Diag button", page 38

5.5.1 Diagnosis/check values

Menu 3.1: Diagnosis/Check values

Status: Measuring	
Check values	3.1
<ul style="list-style-type: none"> 1 Zero drift 2 Reference energy 3 Amplification 4 Intensity 	
/Diag/Chkv	
Back	<input type="button" value="↑"/> <input type="button" value="↓"/> <input type="button" value="Enter"/>

[see "Zero drift", page 37](#)
[see "Reference energy", page 37](#)
[see "Amplification", page 37](#)
[see "Intensity", page 38](#)

5.5.1.1 Zero drift

Menu 3.1.1: Diagnosis/Check values/ Zero drift

Status: Measuring	
Zero drift	3.1.1
Reset at 24.08.2011 <ul style="list-style-type: none"> 1 Comp.1 0.0050 Ext 2 Comp.2 0.0004 Ext 3 Comp.3 0.0012 Ext 	
/Diag/Chkv/Dri	
Back	<input type="button" value="↑"/> <input type="button" value="↓"/> <input type="button" value=" "/>

The zero drift since the last "Reset" of the zero drift (e.g., during maintenance, [see "Parameter/reset", page 41](#)) is shown in this menu.

The zero drift is recalculated during each zero adjustment and displayed in extinction.

This value can be used for system diagnosis.

Typical cause: Decrease in lamp energy, contamination of cell windows.

5.5.1.2 Reference energy

Menu 3.1.2: Diagnosis/Check values/Reference energy

Status: Measuring	
Reference energy	3.1.2
Reset at 24.08.2011 <ul style="list-style-type: none"> 1 Comp.1 98 % 2 Comp.2 99 % 3 Comp.3 97 % 	
/Diag/Chkv/Refe	
Back	<input type="button" value="↑"/> <input type="button" value="↓"/> <input type="button" value=" "/>

The actual reference energy (in percent) is shown in this menu. This value is monitored automatically. If the value is below a limit value (default: 60%), the MCS300P switches to classification "Maintenance request". Typical cause: Contamination of cell windows or decrease in lamp energy.

A "Reset" ([see "Parameter/reset", page 41](#), e.g., during maintenance) sets the reference energy to 100%.

5.5.1.3 Amplification

Menu 3.1.3: Diagnosis/Check values/Amplification

The amplification levels of the measured components are shown in this menu.

The amplification levels serve as information for Endress+Hauser Customer Service.

5.5.1.4 Intensity

Menu 3.1.4: Diagnosis/Check values/Intensity

The intensities (energies) of the measured components are shown in this menu.

The amplification levels serve as information for Endress+Hauser Customer Service.

5.5.2 Diagnosis/temperatures

Menu 3.2: Diagnosis/Temperatures

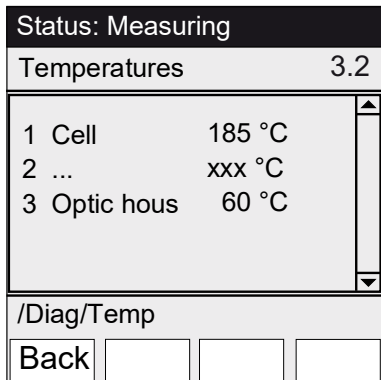

The actual temperatures are shown in this menu.

5.5.3 Diagnosis/system info

Menu 3.3: Diagnosis/System info

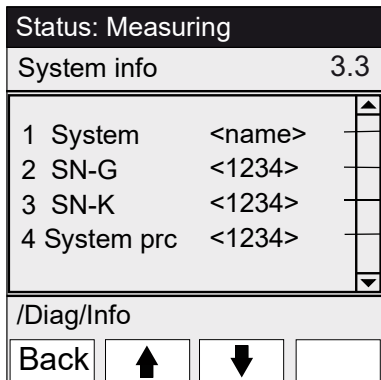

Device numbers and software versions are shown in this menu.

- Name of the system
- Serial number of device
- Serial number of cell
- System software version
- Etc.

5.5.4 Diagnosis/error messages and Diag button

Menu 3.4: Diagnosis/Error messages and <Diag button>

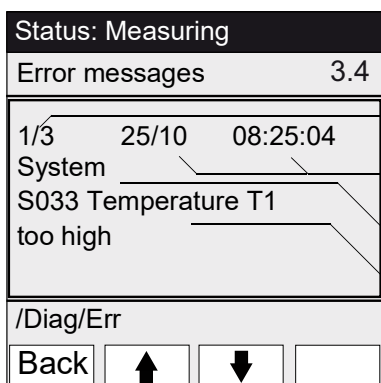

Existing messages are shown in this menu (Logbook → SOPAS ET).

- Message number / number of existing messages
- Date of occurrence (dd/mm)
- Time of occurrence (hh:mm:ss)
- Source (e.g., system, measured component, receiver, etc.)
- Error cause (error number and plain-text)
(list of messages, see "Error messages and possible causes", page 55)

5.6 Parameter setting

Menu 4: Parameter

Status: Measuring			
Parameter	4		
1 Display 2 Reset			
/Para			
Back	↑	↓	Enter

see "Parameter settings/display",
page 39
see "Parameter/reset", page 41

5.6.1 Parameter settings/display

Menu 4.1: Parameter/Display

Status: Measuring			
Display	4.1		
1 Scale 1 - 8 2 Scale 9 - 16 3 Timeline			
/Para/Disp			
Back	↑	↓	Enter

see "Scale", page 40
see "Scale", page 40
see "Timeline", page 40

5.6.1.1 Scale

Menu 4.1.1: Parameter/Display/Scale 1 - 8

Menu 4.1.2: Parameter/Display/Scale 9 - 16

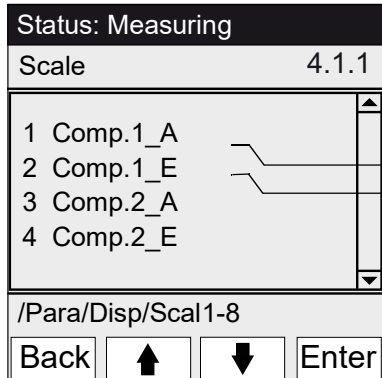

Bar graphs and line graphs are scaled in this menu. The scaling shown is valid for both types of graph. Graph update interval: 1 second.

- _A: Scaling start value
- _E: Scaling end value

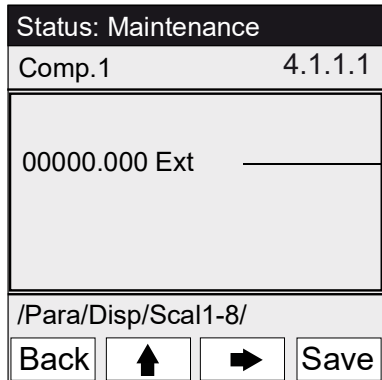

Enter the numeric value. For a minus sign: Press \uparrow 10 times before first digit. Invalid entries (start value > end value) are not accepted.

5.6.1.2 Timeline

Menu 4.1.3: Parameter/Display/Timeline

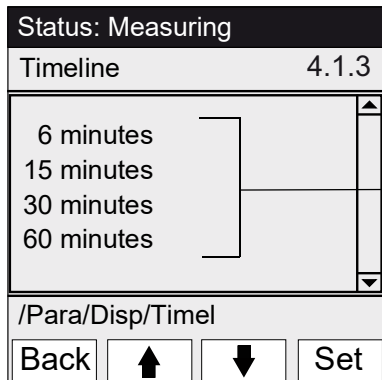

The parameters of the line graph timeline are set in this menu. Graph update interval: Depending on scale (see “Line graph Measuring screen”, page 27)

Timeline end value (specified times)

5.6.2 Parameter/reset

Menu 4.2: Parameter/Reset

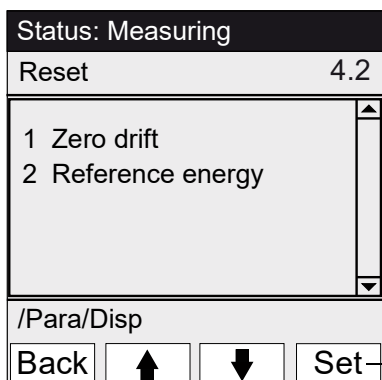

In this menu, the drifts/reference energies for all components are set to:

- "0" (for zero drift)
- "100%" (for reference energy)



The complete history is lost when the drifts/reference energies are reset.

- ▶ Reset the drifts/reference energies only when you are sure that you want to reset the values.

6 Shutdown

6.1 Shutdown

**CAUTION: Hazards through electric voltages**

- ▶ Only let the work described in the following be carried out by skilled electricians who can recognize potential risks.
- ▶ Before opening the enclosure: Separate all connectors of the MCS300P from the main power supply.

**CAUTION: Acid, risk of chemical burns**

The cell and the connected hoses could contain caustic or corrosive media (noxious or irritating substances).



Risk of splashing when tubes are removed or cut off.

- ▶ Take suitable protective measures when working on parts having contact with the measured medium (e.g., wear protective goggles or a safety mask, protective gloves and acid-proof protective clothes).

**CAUTION: Risk of contamination when the device is switched off**

When the device is switched off, there is a risk of contamination by medium remaining in the cell.

- ▶ Before switching off the device, purge the connected cell and tubes for a sufficient period with an inert medium.



To switch the device off for a short time, use the “System stop” function (see “System stop”, page 30).

- 1 Set the maintenance signal (see “Maintenance/maintenance signal”, page 29).
- 2 Feed the inert medium into the cell:
 - manually or
 - with the program (If parameters were set).
3. Allow the MCS300P to run in this state long enough so that the cell and the connected tubes are purged of the measured medium (duration depends on the measured medium).
4. Disconnect the MCS300P from the main power supply.
5. If heated subassemblies are connected: Disconnect these subassemblies from the main power supply.
6. If necessary, remove liquid from the cell and allow the cell to dry.

6.2 Disposal

- ▶ The MCS300P can easily be disassembled into its components which can then be sent to the respective raw material recycling facilities.

**WARNING: Gases in gas filters**

Depending on the application, MCS300P sample gas filters (option) contain minor gas volumes which represent a hazard only under particularly unfavorable circumstances.

- ▶ Do not destroy sample gas filters directly in front of your face and do not directly breathe in emerging gases.
- ▶ Do not destroy sample gas filters in small, closed rooms, especially when large quantities must be destroyed.

The sample gas filters are located on the filter wheel in the receiver unit.



The following subassemblies contain substances that may have to be disposed of separately:

- *Electronics*: Condensers, batteries.
 - *Display*: Liquid of LC display.
 - *Sample gas paths*: Toxic substances of the measured medium can adhere to soft materials of the gas path (e.g., tubes, O-rings) or penetrate them.
-

7 Maintenance

7.1 Spare parts



NOTICE: Risk of malfunctions when using wrong spare parts

► Use original Endress+Hauser spare parts only.

7.1.1 Recommended spare parts

Spare part	Part No.
Desiccant cartridge (including assembly key)	2010549
Halogen lamp ^[1]	6023466
IR source insert ^[1]	2024574
IR chopper / source unit complete	2045537
UV chopper / source unit complete	2047806
Cell-dependent spare parts → Cell Manual or System Documentation	

[1] Depending on device configuration

7.2 Maintenance plan

Interval ^[1]	Maintenance work	Reference
1W	Visual inspection	see "Visual inspection", page 45
	Check the measured values for plausibility	
	Device with VIS source: Adjustment with zero gas ^[2] ^[3]	see "Adjustment", page 32
1M	Device with IR source: Adjustment with zero gas ^[2] ^[3]	see "Adjustment", page 32
	Adjustment with internal adjustment standard ^[4]	see "Adjustment/automatic", page 33
6M	Check the desiccant cartridge and replace if necessary	see "Checking/replacing the desiccant cartridge", page 46
	Adjustment of all measuring components with test medium	see "Adjustment", page 32
1Y	Device with VIS source: Replace the source ^[2]	Replacement by trained skilled person or Endress+Hauser Service
	Recommendation: Maintenance work on the cell	see Operating Instructions of the cell
	Device with IR source: Check reference energy	see "Reference energy", page 37
3Y ^[5]	Device with IR source: Replace the source ^[2]	Replacement by trained skilled person or Endress+Hauser Service

[1] 1W = weekly, 1M = monthly, 6M = half-yearly, 1Y = yearly

[2] Source type, see system documentation

[3] Not required for devices with automatic zero point adjustment (see system documentation)

[4] Option. See system documentation

[5] Recommendation

7.2.1 Before commencing maintenance work

Before starting maintenance work, consider the following as applicable:



CAUTION: Risk of contamination when the device is switched off

When the device is switched off, there is a risk of contamination by medium remaining in the cell.

- Before switching off the device, purge the connected cell and tubes for a sufficient period with an inert medium.

- Set the maintenance signal (menu 1.1).
- Disable "Cyclic programs" (menu 2.3.3 or 2.3.4).

7.2.2 Observe before opening the device enclosure



CAUTION: Hazards through electric voltages

- ▶ Before opening the enclosure: Separate all connectors of the MCS300P from the main power supply.



WARNING: Risk of toxic gases in receiver unit

- If the device is not operating correctly, it is possible that a gas-filled filter is leaky and the gas is in the receiver unit.
- ▶ If it is necessary to open the receiver unit, do so in a well-ventilated room.

7.2.3 Visual inspection

MCS300P

- Only the “green” LED on the operator panel lights and *no* measured value blinks. Otherwise: Press the <Diag> button to view the cause.
- Perform a visual inspection of the device enclosure
 - Dryness
 - Corrosion
 - Unusual smell
 - Unusual noises

Peripherals

- Sampling and discharging measured medium, tubes: Condition.
- Test gas supply: Condition, availability (use-by date), pressures.
- If available: Purge gas supply: status, availability, pressures.

7.2.4 Zero and test gas feed

Feed a test gas with a defined test gas concentration (nominal value) and compare the displayed measured value with the nominal value.

- ▶ Feed the test gas at the cell inlet (For systems: See System Description delivered with the system).
- ▶ Test gas flow: Max. 200 l/h (to ensure adequate temperature and to avoid pressure build-up).



The test gas must have approximately the same temperature as the cell (See System Description delivered with the system).

- ▶ E.g., provide heated lines.

- ▶ Observe an adequate run-in time of the test gas until the measured value is stable.

In case of deviation:

- ▶ Check the gas flow
- ▶ Check the gas path for leak tightness
- ▶ Correct the measured value:
 - If programmed: In Menu “[Adjustment/automatic](#)”, [page 33](#) and see provided System Description
 - Or in Menu “[Adjustment/manual](#)”, [page 32](#) or in the respective menu in SOPAS ET

7.2.5 Checking/replacing the desiccant cartridge



Observe information on opening the enclosure (see “Observe before opening the device enclosure”, page 45).

Spare parts	Part No.	Required for
Desiccant cartridge with key	2010549	----

Tool
5 mm Allen key

Fig. 11: Receiver unit screws

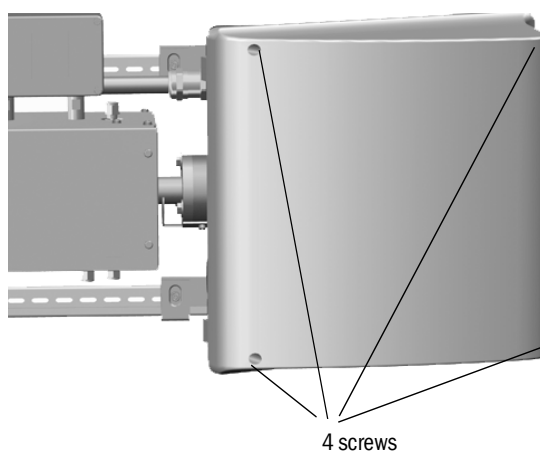

- 1 Separate the MCS300P from the main power supply using the external main power switch.
- 2 Unscrew the 4 screws (5 mm Allen key) of the receiver unit.
- 3 Open the cover.

Fig. 12: Desiccant cartridge

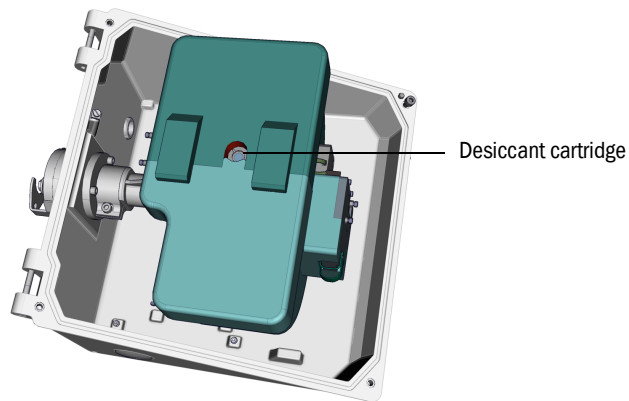

- 4 When the desiccant cartridge is *light blue*: Desiccant cartridge is dry and OK.
When the desiccant cartridge is *pink*: Desiccant cartridge is damp.
 - ▶ Renew the desiccant cartridge.
- 5 Replace the desiccant cartridge:
 - a) Unscrew the desiccant cartridge with the key.
 - b) Screw in the new desiccant cartridge.
- 6 Close the receiver unit again.
Make sure sealing surfaces are clean and seals are properly seated.
- 7 Start the MCS300P again ([“Starting-up the MCS300P”](#), page 25).

7.2.6 Removing/installing the cell



CAUTION: Acid, risk of chemical burns

The cell and the connected hoses could contain caustic or corrosive media (noxious or irritating substances).



Risk of splashing when tubes are removed or cut off.

- ▶ Take suitable protective measures when working on parts having contact with the measured medium (e.g., wear protective goggles or a safety mask, protective gloves and acid-proof protective clothes).



WARNING: Hot surfaces

- ▶ Before touching heated subassemblies, allow to cool down first.



CAUTION: Risk of contamination when the device is switched off

When the device is switched off, there is a risk of contamination by medium remaining in the cell.

- Before switching off the device, purge the connected cell and tubes for a sufficient period with an inert medium.



Observe information on opening the enclosure (see [“Observe before opening the device enclosure”, page 45](#)).

Spare parts	Number	Part No.
O-ring (cell flange)	2	5310003 (1 pc)
Cell-dependent spare parts → Cell Manual or System Documentation		

Tool
4 mm Allen key
10 mm open-end wrench
30 mm open-end wrench

Preparation work

- 1 Note reference energy *and* intensities (see menu: *Diagnosis/Check values*) (to compare the energy after installation).
- 2 Put the MCS300P out of operation and disconnect from the main power supply with the external main power switch.

Removing the cell

Fig. 13: Screw connections on receiver side

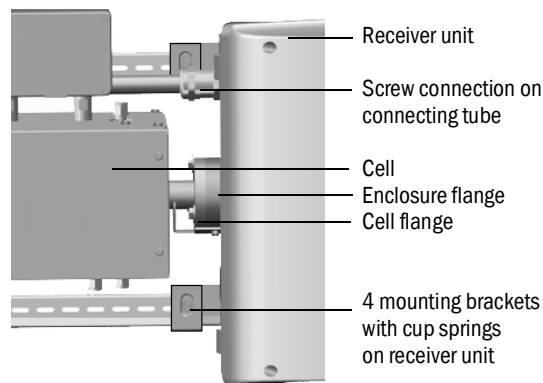

- 1 Mark the position of the cell with a marking line on the cell flange and on the enclosure flange.
- 2 Remove all tubes from the cell.
- 3 If necessary, disconnect the cell electric lines on the cell (→ Cell Operating Instructions).
- 4 Loosen the 4 mounting brackets on the receiver unit (do not remove).
- 5 Unscrew the screw connection of the connecting tube on the receiver unit side (see [“Connecting tube, receiver side”, page 51](#)).
- 6 Unscrew the 3 screws of the vario flange (on sender and receiver unit).

Fig. 14: Vario flange (as shown on the sender unit)

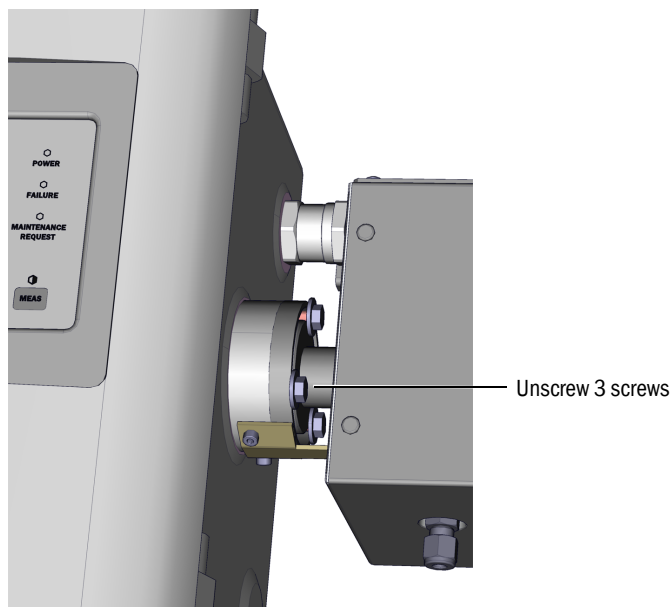

- 7 Push the receiver unit approx. 5 mm to the right or down.



NOTICE:

Vertical installation: Make sure that the receiver unit does not slide down out of the G-type rails and drop down.

- 8 Remove the cell.
Vertical installation: Immediately tighten the retaining brackets of the receiver unit.



Information on work on the cell or cell heater:
→ Cell Operating Instructions and System Documentation.

Installing the cell

- Preferred cell position
 - Mount the cell according to the marking made during removal.
 - Otherwise:
 - Gas cell: Gas feed and drain lines from below, heating connection up.
 - Liquid cell: Liquid inlet from below, liquid outlet up.
- 1 Place 1 O-ring each into the groove on the sender or receiver unit (the outer groove remains empty).

Fig. 15: Installation of cell (shown on the sender unit)

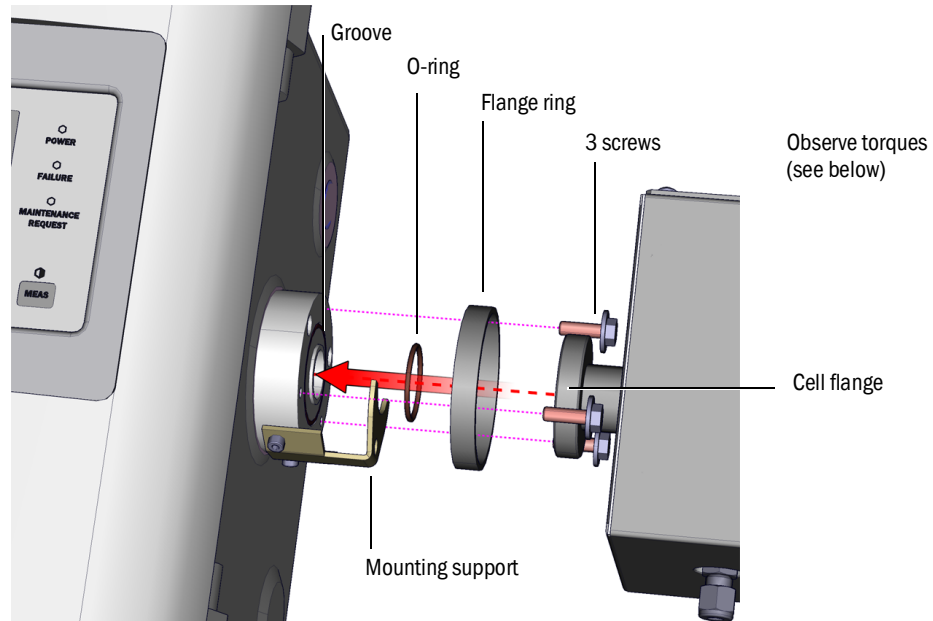

- 2 Insert the cell: Place the flange ring and cell flange on the flange of the sender or receiver unit (see “Installation of cell (shown on the sender unit)”).
- 3 Turn the cell into the correct position (according to the marking made during removal) and push the receiver unit to the left or upwards until the cell is clamped.
- 4 Screw on the cell on the receiver and sender side with 3 screws each (M6x20, DIN 933) and 2 washers each (DIN 137 and DIN 9021).

Fig. 16: Connecting tube, receiver side

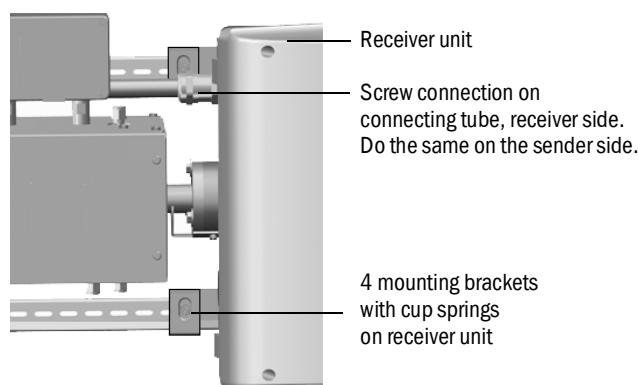

- 5 Tighten the screw connection of the connecting tube again.
Torques:
 - Receiver side: 1 Nm (see [“Connecting tube, receiver side”](#), page 51)
 - Sender side: 2 Nm
- 6 Screw the 4 mounting brackets and cup springs loosely on the receiver unit so that enough clearance remains for temperature equalization.

Final steps

- 1 Screw the tubes for the measured medium back onto the cell.
- 2 If necessary, connect the electric lines to the cell heating.
- 3 Perform a leak test (depending on the cell and measured medium used).
- 4 Put the MCS300P back into operation.
- 5 Compare the intensity (Menu: *Diagnosis/Check values/Intensity*) with the notes made:
The intensity must not have deteriorated significantly.
If this is the case: Please contact Endress+Hauser Service.
- 6 Compare the reference energy (Menu *Diagnosis/Check values/Reference energy*) with the notes made: The reference energy must not have deteriorated significantly.
If so: Reset reference energy (see Menu: *Reset/Reference energy*).
- 7 Perform the adjustment of zero point and span point (see Menu *Adjustment*).

8 Clearing malfunctions

8.1 If the MCS300P does not function at all ...

Possible cause	Notes
Main power supply has failed.	Check main power supply (e.g., external switch, external fuses).
Defective internal fuse.	Check fuses (see “Fuses”, page 53).
Software not working correctly.	Switch the MCS300P off with the external main power switch and switch it on again after a few seconds.

8.2 When measured values are obviously incorrect ...

Possible cause	Notes
The MCS300P is not measuring the measured medium.	Check measured medium path and all valves (e.g., switching from the test medium to measured medium).
Measured medium path leaks.	Check installations.
The MCS300P is not correctly adjusted.	Perform an adjustment (see “Adjustment”, page 32); check the test media first (nominal value, service life, throughflow and the concentrations in Menu 2.3.1).

8.3 Malfunction messages

A malfunction has occurred when:

- The measured values blink.
- The “yellow” LED lights.
- The “red” LED lights.
- ▶ Press the <Diag> button for more information (list with error messages and possible causes, see [“Error messages and possible causes”, page 55](#)).



For more information concerning operating and display elements, see [“Operating and display elements”, page 22](#)

8.4 Fuses

Fig. 17: Fuses

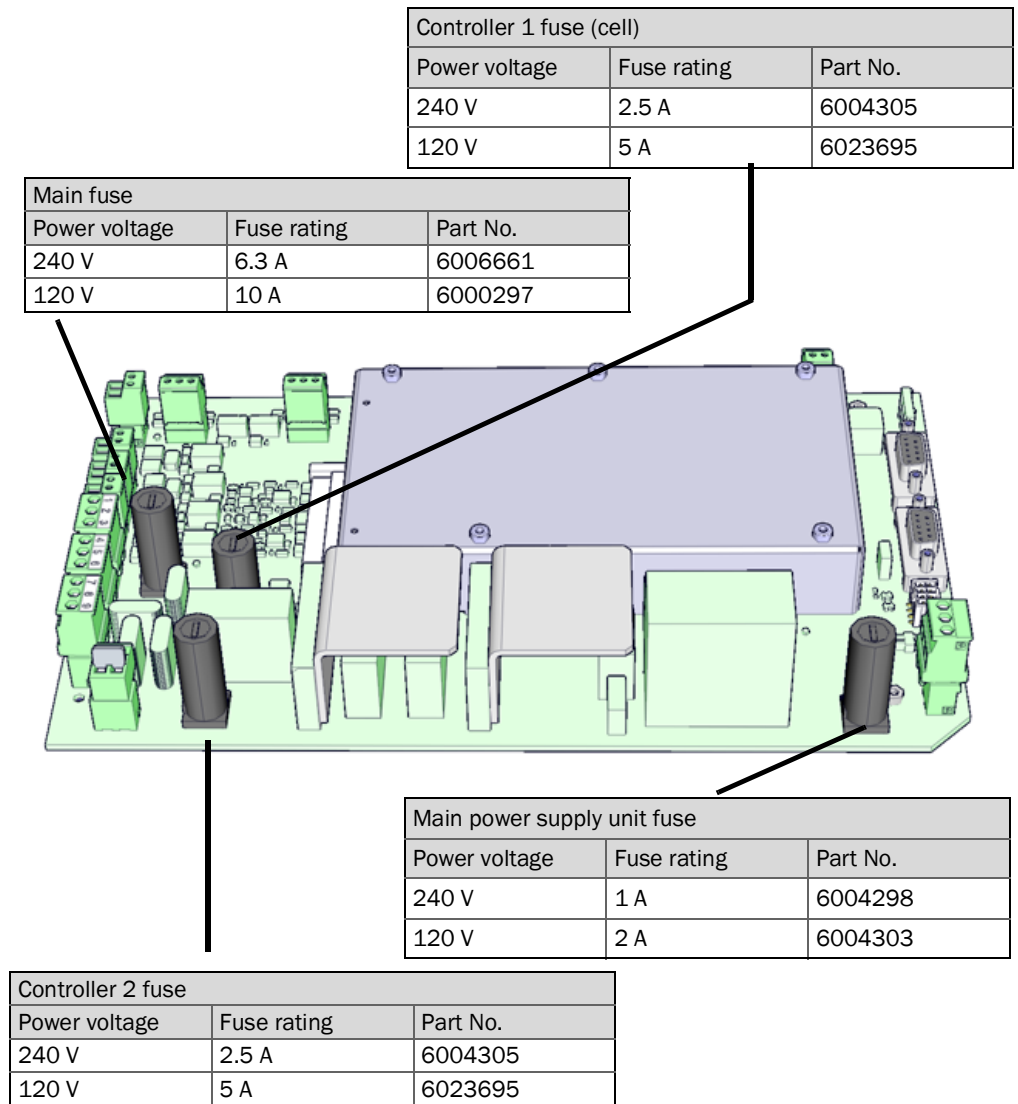

- 1 Switch the MCS300P off with the external main power switch.
- 2 Unscrew the 4 screws of the sender unit (5 mm Allen key).



WARNING: Risk when opening the sender unit

► Observe warning information, see [“Opening the sender unit”, page 19](#) and see [“Observe before opening the device enclosure”, page 45](#)

- 3 Open the cover.
- 4 Check and, if necessary, replace the fuses.



NOTICE:

Fuse ratings depend on the power voltage.
 ► Only use fuses with the correct fuse rating.

- 5 Close the sender unit. Ensure gas tightness.

8.4.1 LEDs on circuit board

If no LED is on: Check “Power supply unit” fuse (see “Fuses”, page 53).

Fig. 18: LEDs position

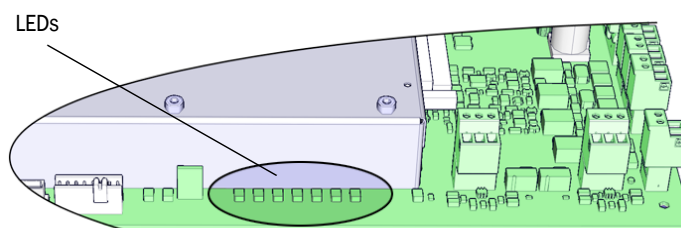

8.5 Error messages and possible causes

Source	Code	Error text	Classification	Description	Possible clearance ^[1]
System	S001	Temperature T1 too high	Failure	If T1 > (nom.temp + param.limit)	Check the heater
	S002	Temperature T2 too high		If T2 > (nom.temp + param.limit)	
	S003	Temp. 1 not reached		After 60 min. in current operation: 15 min	
	S004	Temp. 2 not reached			
	S005	Temperature sensor 1		OVO (HC3X) signals that the input range of an analog input (temperature sensor) was exceeded	
	S006	Voltage range		OVO (HC3X) signals that the input range of an analog input (temperature sensor) was exceeded	Please contact Endress+Hauser Customer Service
	S007	Check sum error		OVO (HC3X) signals that the input range of an analog input (temperature sensor) was exceeded	
	S008	Chopper signal missing		This message is first displayed when the receiver has set the corresponding bit 5 times (seconds) in succession	
	S009S S010 S011	Motor x: Ref.pos.incorrect		Filter wheel motor x does not detect the reference position	
	S012	No emitter detected		No emitter detected	Check the voltage supply of the emitter and replace if necessary
	S013	Communication error		During important routines or when S062 occurred 30 times	Please contact Endress+Hauser Customer Service
	S014	No result		No measval or ecorr file	
	S015 S016 S017	Motor x: defect		If, from system start, 30 step losses or 30 watchdog actions	
	S018	Source failure		Detection I < 0.1 A	Check the emitter and replace if necessary
	S019	Chopper error		Detection: f_Motor < 50 Hz or sender SW signals chopper error	Please contact Endress+Hauser Customer Service
	S020	Configuration error		CONF (HC3X)	
	S021	Communication error		COM (HC3X)	
	S022	Controller not found		EXIST (HC3X)	
	S023	Frequent reset		Receiver, sender. If error occurred 30 times as from system start	
	S024	No active component		If "Active" checkmarks of all components disabled	

[1] This Table also contains recommended solutions that should only be performed by specially trained personnel.

Source	Code	Error text	Classification	Description	Possible clearance ^[1]
System	S025	Evaluation module failure	Failure	Evaluation module could not be started	Please contact Endress+Hauser Customer Service
	S026	Evaluation module: File error		Files for evaluation module were not set up (espec, config, condition, measval)	
	S027	Updating low		TOO (HC3X)	
	S028 S029 S030	Motor x: communication		No communication with motor x	
	S031	Optics temp. too high		If optics temp. > 1.05 * 60 °C = 63 °C	
	S032	Temperature sensor 1		OVO (HC3X) signals that the input range of an analog input (temperature sensor) was exceeded	Check the heater
	S113	Check sum error		BCK (I/O) indicates that the transmission process performed beforehand from the master to the slave (controller) had an incorrect check sum and the slave has not accepted the data.	Check the I/O modules, cable damage
	S114	Communication error		COM (I/O) communication error with an I/O module	
	S115	High/low voltage		PFO (I/O) signals that the internal voltage supply of the 5 V and 24 V supply voltages has determined a range overflow or underflow	Please contact Endress+Hauser Customer Service
	S116	Output without current		TOO (I/O) signals that the output was switched to a currentless condition because of the time-out	Check the I/O modules, cable damage

[1] This Table also contains recommended solutions that should only be performed by specially trained personnel.

Initiator	Code	Error text	Classification	Description	Possible clearance ^[1]
System	S033	Dev. zero point too high	Maintenance request	Parameters set for measured component	Check the zero gas, contamination
	S034	Configuration I/O module		CONF (I/O) configuration error, module found does not correspond to nominal configuration	Check the IO modules, check the parameters: IO hardware plan
	S035	Ref.energy too low		Parameters set for measured component	Check the emitter current, contamination: clean/replace cell window
	S036	Optics temp. not reached		Delay time: 1800 s = 30 min	Please contact Endress+Hauser Customer Service
	S037	VIS: source current low		Only UV: current: 50% (I_max = 2.8 A) -> message If I < 1.4 A	Check the emitter and replace if necessary
	S038 S039	Channel x error		OVO (I/O) signals that the current required on the analog module connection (node y, module z) is not reached.	Check the I/O modules, cable damage
	S042	Busy		BSY (I/O and HC3X) signals that the microcontroller of the module is still busy executing the last command	Please contact Endress+Hauser Customer Service
	S043	IR: Emitter voltage high		Only IR: Voltage: 150% of V_max (V_max = 3.5 V) -> message If U > 5.3 V	Check the emitter and replace if necessary
	S044	Chopper tight		Detection: If setting variable > 1000	Please contact Endress+Hauser Customer Service
	S045	Factor invalid: medium		If the F_Medium calculation is refused because it is outside the tolerable range; parameters set with measured component	Check the test gas, check the input of the test gas concentration, contamination
	S046	Factor invalid: filter		If the F_Filter calculation is refused because it is outside the tolerable range; parameters set with measured component	Check the zero gas, contamination
	S049	FlashCard not detected		FlashCard not detected	Please contact Endress+Hauser Customer Service
	S050	Factor=zero medium/filter		If one of the factors F_Medium or F_Filter is in the range - 0.000001 < x < 0.000001	Check the test gas, check the input of the test gas concentration, contamination

[1] This Table also contains recommended solutions that should only be performed by specially trained personnel.

Initiator	Code	Error text	Classification	Description	Possible clearance ^[1]
System	S057	sin/cos-overflow	Uncertain	If at least one value of 100 averaged less than -2 ¹⁵ or greater than +2 ¹⁵	Please contact Endress+Hauser Customer Service
	S058	Temperature 1 too low		If T1 < nom.temp. - param.limit	Wait. After a restart, max. 60 min., during operation: 15 min
	S059	Temperature 2 too low		If T2 < nom.temp. - param.limit	
	S060	Temp. optics too low		If optics temp. < 60 °C * 95% = 57 °C	Wait for max. 30 min.
	S061	Chopper frequency range		If chopper frequency: 125 < x < 131	Please contact Endress+Hauser Customer Service
	S062	Communication problem		Sender and receiver for cyclic routines (reading out of measurement signals, diagnosis values)	
	S063	Wrong no. of filter wheels		According to the SOPAS ET parameters, fewer filter wheels defined than actually present in the device	Check the SOPAS ET parameters

[1] This Table also contains recommended solutions that should only be performed by specially trained personnel.

Initiator	Code	Error text	Classification	Possible clearance
Evaluation process	E001	Unknown command	Failure	Please contact Endress+Hauser Customer Service
	E002	OS error		
	E003	Incorrect configuration		
	E004	Incorrect configuration		
	E005	Internal file error		
	E006	Incorrect configuration		
	E007	Internal file error		
	E008	Internal file error		
	E009	Internal file error		
	E010	Incorrect configuration		
	E011	Incorrect configuration		
	E012	Incorrect configuration		
	E013	Internal file error		
	E021			
	E022	Resolution out of range		
	E023	Numerical error		
	E024	Incorrect configuration		
	E025	Internal file error		
	E026	Numerical error		
	E027	Incorrect configuration		
	E028	Incorrect configuration		
	E029	Unknown failure		
	E030	OS error		
	E031	OS error		
	E032	Internal file error		
	E033	Internal file error		
	E034	Internal file error		
	E035	Numerical error		
	E036	Syntax error		
	E037	Processing error		
	E038	Absorption too high		
	E039	Internal file error		
	E040	Internal file error		

Initiator	Code	Error text	Classification	Possible clearance
Evaluation process	E097	Evaluation uncertain	Uncertain	Please contact Endress+Hauser Customer Service
	E098	Medium temp. too high/low		
	E099	Medium pressure too high/low		
	E100	Medium flow too high/low		
	E101	Measured value too high/low		
	E102	Evaluation uncertain		
	E103	Evaluation uncertain		

9 Specifications

9.1 Compliances

The technical design of this device complies with the following EU directives and EN standards:

- EC Directive: LVD (Low Voltage Directive)
EN 61010-1: Safety requirements for electrical equipment for measurement, control and laboratory use
- EC Directive: EMC (Electromagnetic Compatibility)
EN 61326: Electrical equipment for measurement, control and laboratory use - EMC requirements

Further standards and directives: see Declaration of Conformity delivered with the device

9.2 Technical Data



The MCS300P equipment depends on the application.
Refer to the system documentation delivered with the MCS300P for the fitted equipment.

9.2.1 Dimensions and drilling diagram

Fig. 19: Horizontal installation

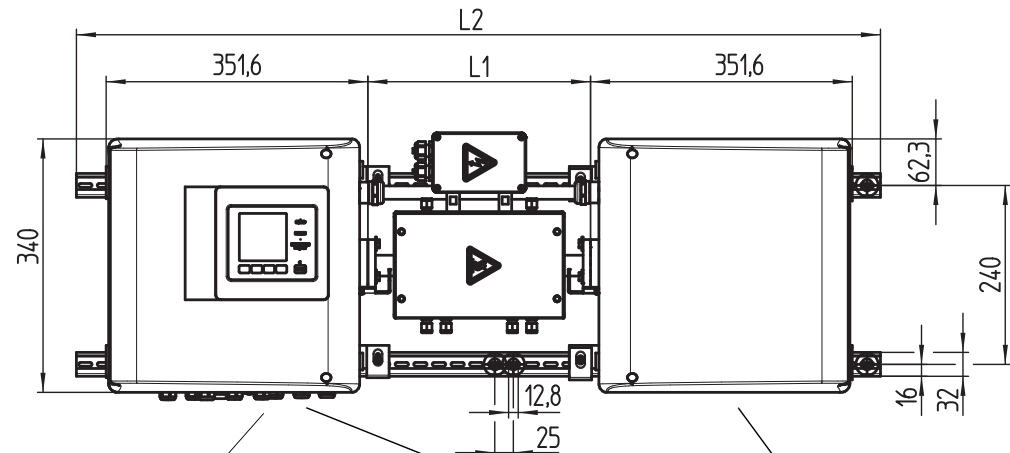

Cable bushings:
 8 * M16x1.5 for Ø 5 - 10 mm (0.2 - 0.4 in)
 1 * M20x1.5 for Ø 10 - 14 mm (0.4 - 0.55 in)
 1 * M12 Ethernet port

Enclosure duct:
 1 * PG9
 2 * M5

Enclosure duct:
 1 * PG29

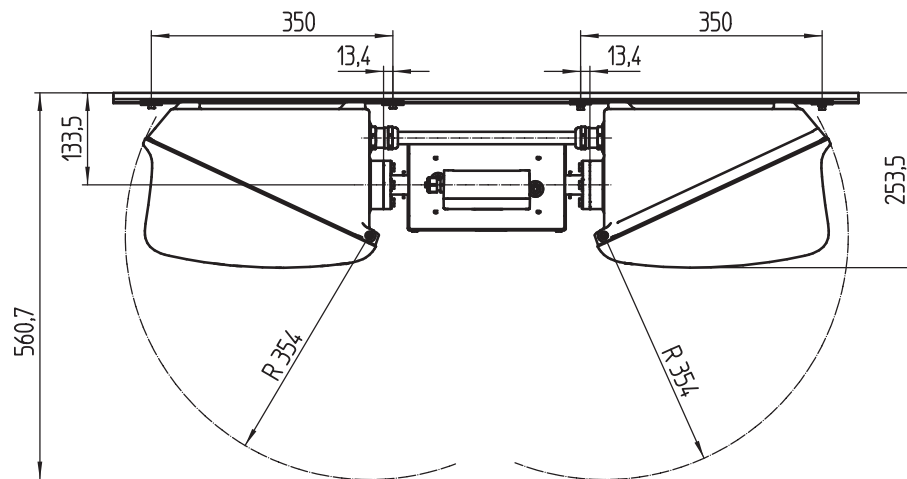

mm	inch
12,8	0.50
13,4	0.53
16	0.63
25	1.0
32	1.3
62,3	2.4
133,5	5.2
240	9.4
253.5	10
340	13.4
350	13.8
351,6	13.8
354	14
400	15.7
560,7	22

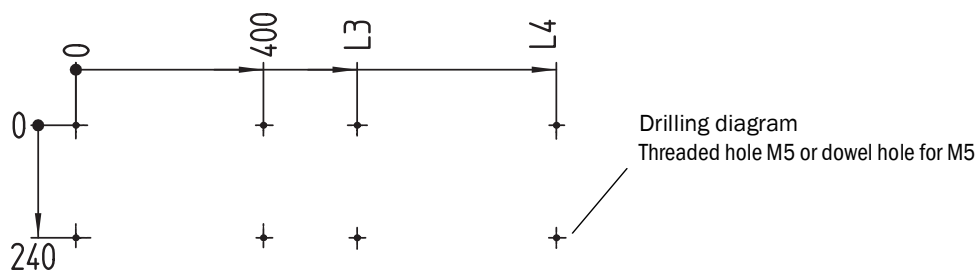

Dimensions in mm (in) and weight in kg (lb) with typical Endress+Hauser cells:

Cell	L1	L2	L3	L4	Total weight
FGK	168 - 229 (6.6 - 9.0)	1000 (39.4)	500 (19.7)	925 (36.4)	33,5 (74)
PGK10	299 (11.8)	1080 (42.5)	600 (23.6)	1025 (40.4)	37 (82)
PGK20	399 (15.7)	1180 (46.5)	700 (27.6)	1125 (44.3)	39 (86)
PGK50	699 (27.5)	1480 (58.3)	1000 (39.4)	1425 (56.1)	45 (99)
PGK75	949 (37.4)	1730 (68.1)	1250 (49.2)	1675 (65.9)	50 (110)
AGK50	647 (25.4)	1428 (56.2)	948 (37.3)	1373 (54)	35 (78)
AGK75	897 (35.3)	1678 (66)	1198 (47.2)	1623 (63.9)	36 (80)

Fig. 20: Vertical installation

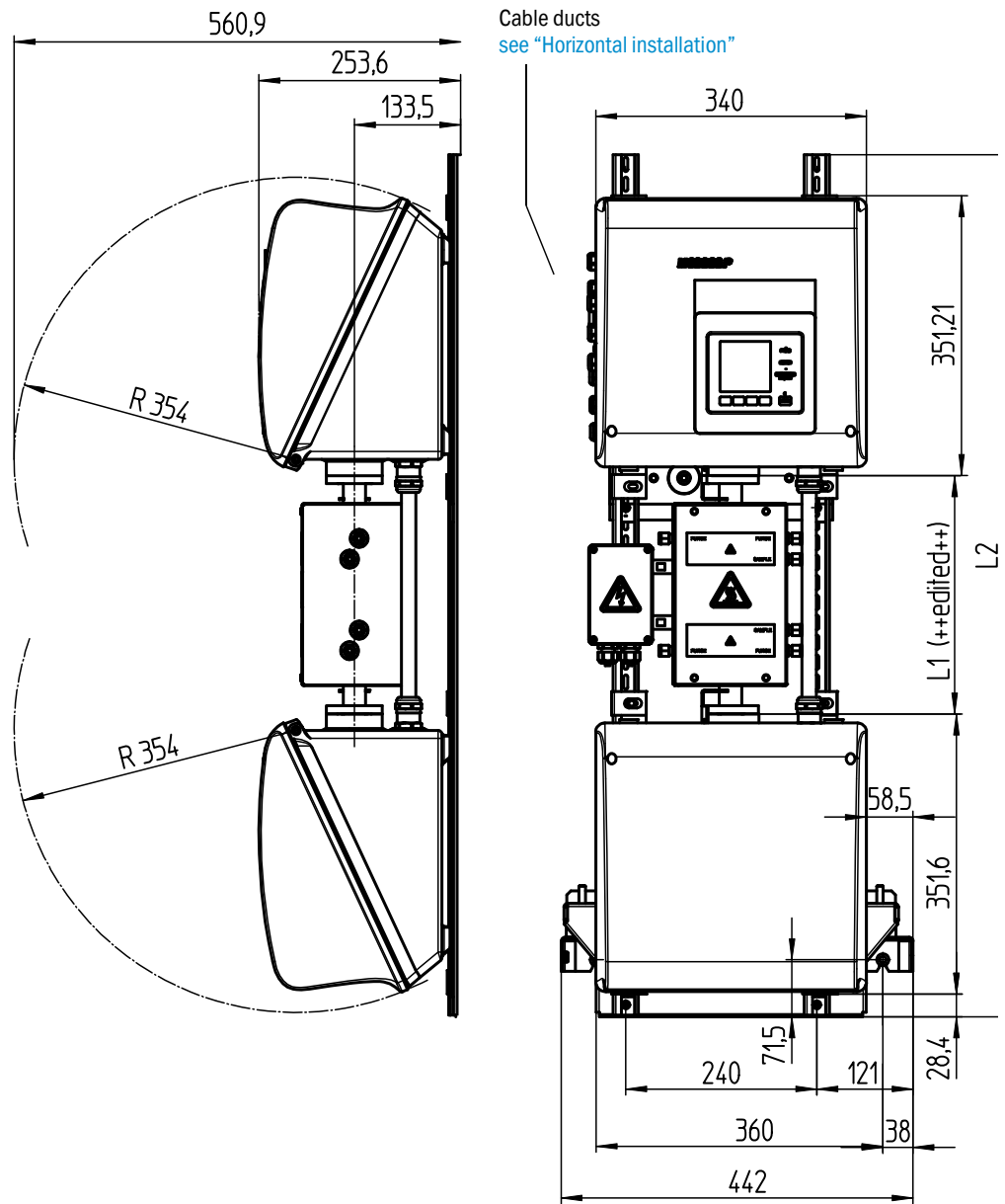

mm	inch
14,5	0.57
28,4	1.12
38	1.5
43	1.7
57	2.2
58,5	2.3
71,5	2.8
85	3.3
100	3.9
101	4
104	4.1
133,5	5.2
157,2	6.2
208	8.2
240	9.4
253,6	10
351,21	13.8
351,6	13.8
354	13.9
360	14.2
560,9	23

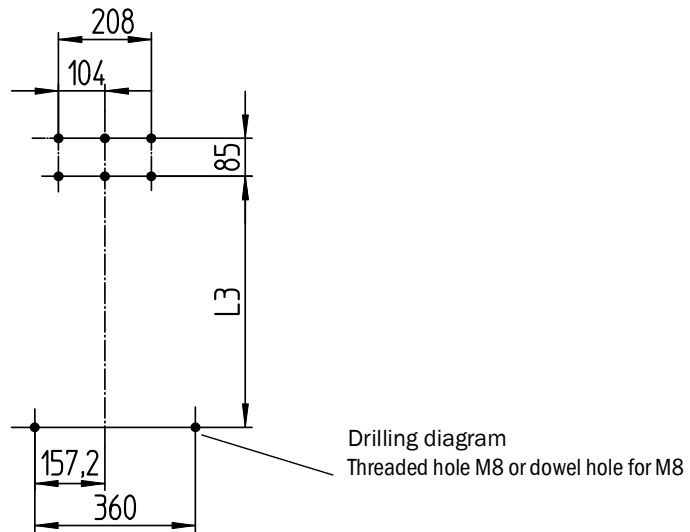

Dimensions in mm (in) and weight in kg (lb) with typical Endress+Hauser cells:

Cell	L1	L2	L3	Total weight
PGK10	299 (11.8)	1080 (42.5)	562 (22.2)	43 (95)
PGK20	399 (15.7)	1180 (46.5)	662 (26.1)	45 (99)
PGK50	699 (27.5)	1480 (58.3)	962 (37.9)	51 (112)
PGK75	949 (37.4)	1730 (68.1)	1212 (47.7)	56 (123)
AGK50	647 (25.4)	1428 (56.2)	910 (35.8)	41 (7)
AGK75	897 (35.3)	1678 (66)	1160 (45.7)	42 (8)

9.2.2 Measured value recording

Measuring principle	Photometer, bifrequency and gas filter correlation method
Spectral range	VIS version: 300 .. 1200 nm IR version: 1200 .. 11000 nm
Measured components	All IR-/NIR-/VIS-active gases and liquids. Simultaneously up to 6 components, e.g., CO, CO ₂ , NO, NO ₂ , N ₂ O, HCl, NH ₃ , H ₂ O, hydrocarbons, Cl ₂ .
External sensors	Read-in and processing of up to 4 external sensors. For example: O ₂ (zirconium oxide), sample gas pressure, sample gas temperature
Number of measuring ranges	2, automatic measuring range switch-over (adjustable)
Cross-sensitivity compensation	Max. 6 disturbance variables (also external disturbance variables)
Detection limit	< 2% of respective measuring range
Zero drift	VIS: < 1% of full scale / day IR: < 2% of full scale / week
Temperature effect	< 2% of respective measuring range / 10 K
Setting time t ₉₀	Approx. 30 ... 120 s, adjustable specific for system and component,
Limit values	2 limit values per measured component
Sample point switching	Max. 8 sampling points

9.2.3 Enclosure specification

Enclosure material	Aluminum, coated
Weight	Approx. 30 kg (66 lb) (without cell)
Degree of protection	IP 65 (cell separate)

9.2.4 Ambient conditions

Ambient temperature	+5 .. +40 °C (+40 .. +105 °F)
Storage temperature	-20 .. +60 °C (-5 .. +140 °F)
Relative humidity	Max. 80% (non-condensing)

9.2.5 Interfaces and protocols

Analog outputs ^[1]	0/4 .. 22 mA, electrically isolated; max. load: 500 Ohm
Analog inputs ^[1]	0/4 .. 22 mA, electrically isolated; input resistance: 100 Ohm
Digital inputs ^[1]	Open contact; potential-free
Digital outputs ^[1]	Power relay, electrically isolated outputs and potential-free outputs
Interface	Ethernet
Bus protocol	Modbus-TCP OPC
PC operation	SOPAS ET via Ethernet

[1] Number dependent on device configuration: → System Documentation

9.2.6 Electrical connection

Supply voltage	1~115/230 V ±10%; 50-60 Hz
Power input	Analyzer: Max. 230 VA - with cell heater: Max. 805 VA - with 2nd heater: Max. 1450 VA
Heater outputs	2 outputs, each max. 550 VA
Line cross-sections	Power voltage: Max. 2.5 mm ² , AWG14, (depending on equipment) Heater for external subassemblies: AWG24-12 Pt100 external subassemblies: AWG26-15
Pt100	4 connections for Pt100

9.2.7 Purge air (optional)

Instrument air	Particle size max. 1 µm, oil content max. 0.1 ppm, dew point -30 °C (-22 °F). Or another suitable medium, e.g.: N ₂
----------------	---

8029888/YNV1/V1-4/2015-09

www.addresses.endress.com
