

Operating Instructions

VISIC50SF

Smoke Detector in Tunnels



Described product

Product name: VISIC50SF

Manufacturer

Endress+Hauser SICK GmbH+Co. KG
Bergener Ring 27
01458 Ottendorf-Okrilla
Germany

Legal information

This work is protected by copyright. Any rights derived from the copyright shall be reserved for Endress+Hauser SICK GmbH+Co. KG. Reproduction of this document or parts of this document is only permissible within the limits of the legal determination of Copyright Law. Any modification, abridgment or translation of this document is prohibited without the express written permission of Endress+Hauser SICK GmbH+Co. KG. The trademarks stated in this document are the property of their respective owner.

© Endress+Hauser SICK GmbH+Co. KG. All rights reserved.

Original document

This document is an original document of Endress+Hauser SICK GmbH+Co. KG.



Symbols and document conventions

Warning symbols



Hazard (general)



Hazard by voltage



Hazard for the environment/nature/organic life

Warning levels and signal words

DANGER

Risk or hazardous situation which *will* result in severe personal injury or death.

WARNING

Risk or hazardous situation which *could* result in severe personal injury or death.

CAUTION

Risk with the possible consequence of minor or slight injuries.

NOTICE

Hazard which *could* result in property damage.

Information symbols



Important technical information for this product



Important information on electric or electronic functions



Supplementary information



Link to information at another place

Data integrity

Endress+Hauser uses standardized data interfaces, such as standard IP technology, in its products. The focus here is on the availability of the products and their properties.

Endress+Hauser always assumes the integrity and confidentiality of data and rights affected in connection with the use of the products are ensured by the customer.

In all cases, the customer is responsible for the implementation of safety measures suitable for the respective situation, e.g., network separation, firewalls, virus protection and patch management.

Contents

1	Important information	9
1.1	About this document	9
1.2	Responsibility of user	9
1.3	Intended use	10
1.3.1	Purpose of the device	10
1.3.2	Product identification	10
1.3.3	Mounting location	10
2	Product description	11
2.1	Features of the VISIC50SF	11
2.2	Device versions.....	12
2.2.1	Standard components: VISIC50SF visibility measurement (K-value).....	12
2.2.2	Optional equipment.....	12
2.2.3	Measuring principle.....	16
2.2.4	Interior view of the VISIC50SF	16
2.3	Interfaces	19
2.3.1	Analog interfaces characteristics	19
2.3.2	Digital interfaces properties	19
2.3.3	Modbus-RTU interface characteristics	19
3	Mounting and electrical installation	20
3.1	Safety information	20
3.2	Material required	21
3.3	Preparing the mounting location	22
3.4	Mounting.....	22
3.4.1	Scope of delivery	22
3.4.2	Mounting the VISIC50SF.....	22
3.4.3	Mounting the connection unit (optional).....	26
3.4.4	Mounting the TAD control unit (optional)	27
3.4.5	Mounting of temperature sensor PT1000 (optional).....	27
3.5	Wiring of VISIC50SF.....	29
3.5.1	Safety information	29
3.5.2	Connecting the LED.....	29
3.5.3	Wiring of analog outputs, relay outputs and voltage supply	31
3.5.4	Bus interface wiring	32
3.5.5	Shielding.....	32
3.5.6	Connection unit wiring	34
3.5.7	TAD control unit wiring.....	35
3.6	Connections	36
3.6.1	Standard version	36
3.6.2	VISIC50SF with connection unit	36
3.6.3	VISIC50SF with TAD control unit.....	37

4	Commissioning	38
4.1	Commissioning, step by step.....	38
4.2	Bus connections.....	40
4.3	Modbus-RTU (integrated in the VISIC50SF standard version).....	40
4.3.1	Modbus-RTU data format	40
4.3.2	Modbus-RTU baud rates	40
4.3.3	Read Holding Register	41
4.3.4	Modbus-RTU Read Coil (0x01)	42
4.4	PROFIBUS DP-V0 (optional)	42
4.4.1	PROFIBUS addressing	42
4.4.2	PROFIBUS DP-V0 baud rates.....	43
4.4.3	Access via GSD file for configuration 1	43
4.4.4	Access via GSD file for configuration 2	44
4.4.5	Measured value coding	46
4.5	RS-485 - topology and bus termination	47
4.6	Stub line lengths for connection unit on all RS-485 bus systems.....	48
5	Operation	49
5.1	Operating and display elements.....	49
5.1.1	Display with keypad in VISIC50SF.....	49
5.1.2	Reset button and “Maint” LED.....	49
5.1.3	Display unit in the TAD control unit	49
5.2	Operating states.....	50
5.2.1	Checking the operating state (visual control).....	50
5.2.2	Checking malfunction displays	50
5.3	Checking the analog outputs.....	50
5.3.1	Reading off measured values	50
5.4	Operating functions.....	51
5.5	Status messages.....	51
5.5.1	Malfunction messages	51
5.5.2	Maintenance request messages,.....	51
6	Menu navigation VISIC50SF.....	52
6.1	Menu structure.....	52
6.1.1	Short description: Settings using the keypad.....	52
6.1.2	Input field with a blinking digit to be edited	52
6.2	Measuring operation mode “RUN”	52
6.3	“SET” mode	53
6.3.1	Navigation in “SET” mode	53
6.3.2	Structure and sequence of submenu items	53
6.3.3	Activating maintenance in menu item “Maint”	54
6.3.4	Calling up maintenance request and malfunction messages with menu item “Status”	54
6.3.5	Calling-up the operating duration in submenu item “Uptime” ...	55
6.3.6	Calling up the software version in submenu item “SwVers”	55

- 6.4 Connecting the bus systems.....56
 - 6.4.1 Setting the RS-485 interface with submenu item “Bus”56
- 6.5 Setting bus parameters57
 - 6.5.1 Setting the PROFIBUS address in “PB ID”57
 - 6.5.2 Setting the PROFIBUS configuration under “PBCONF”57
 - 6.5.3 Setting the Modbus address in “MB ID”58
 - 6.5.4 Setting the Modbus data transfer format with menu item “MB Par”58
 - 6.5.5 Setting the Modbus baud rate with menu item “MB BdR”59
- 6.6 Testing digital/analog outputs60
 - 6.6.1 Signal test “IO test”60
 - 6.6.2 Testing the analog output for the K-value with menu item “k” ..60
 - 6.6.3 Testing the analog output for the temperature value with menu item “Temp”61
 - 6.6.4 Testing the “Maintenance request” relay with menu item “MRq”61
 - 6.6.5 Testing the malfunction relay with menu item “Fail”61
 - 6.6.6 Testing the limit value relay with menu item “Limit”62
- 6.7 Upper limit for scaling of analog output with menu item “AO HI”62
- 6.8 Setting limit values in the “Limit” menu item63
 - 6.8.1 Setting the limit value for the visibility value (K-value) using menu item “K”63
 - 6.8.2 Setting the limit value for rate of increase of K-value with menu item “K_G”63
 - 6.8.3 Setting the limit value for the temperature value with menu item “Temp”64
 - 6.8.4 Setting the limit value for the gradient value of the temperature using menu item “Gradient Temp”64
 - 6.8.5 Setting the limit value for contamination with menu item “Contam”64
- 6.9 Setting limit values in menu item “PreLim” (optional)65
 - 6.9.1 Setting the limit value for the visibility value (K-value) using menu item “K”65
 - 6.9.2 Setting the limit value for rate of increase of K-value with menu item “K_G”65
 - 6.9.3 Setting the limit value for the temperature value with menu item “Temp”66
 - 6.9.4 Setting the limit value for the gradient value of the temperature using menu item “Temp_G”66
 - 6.9.5 Setting the pre-alarm value for contamination with menu item “Contam”66
- 6.10 Device adjustment with submenu item “Tuning”67
- 6.11 Setting digital outputs with “DOMode” (optional).....67
- 6.12 Activating/deactivating the heating (optional)68

7	Menu navigation TAD control unit.....	69
7.1	Basic features	69
7.2	Main functions	69
7.3	Switch-on procedure	69
7.4	Operating elements.....	70
7.4.1	LEDs	70
7.4.2	Function buttons.....	71
7.5	Starting operation	72
7.5.1	Initialization phase	72
7.5.2	Measuring screens: List and bar display	73
7.5.3	Displaying the Main menu.....	74
7.5.4	Selecting the menu item	74
7.5.5	Returning to the measuring screen	74
7.5.6	Selecting the menu language	74
7.5.7	Setting the display contrast	75
7.5.8	Changing numerical parameters.....	75
7.6	Activating Maintenance mode.....	76
7.7	Main menu item “Diagnosis”	76
7.7.1	Calling up the operation duration: “Uptime”	77
7.7.2	Retrieving device information with “Device Info”	77
7.7.3	Retrieving the state of peripheral equipment with submenu item “Peripheral”	78
7.7.4	Displaying messages with menu item “Messages”	78
7.8	Testing digital/analog outputs	80
7.8.1	Testing the analog output for the K-value	80
7.8.2	Testing the analog outputs for temperature	80
7.8.3	Testing the “Fault” relay with submenu item “Fault”	81
7.8.4	Testing the “Maintenance Request” relay with submenu item “Maintenance Req.”	81
7.8.5	Testing the relay “Limit value”	81
7.9	Performing settings on the device with menu item “Configuration”	82
7.9.1	Scaling analog outputs with menu item “Scale AO”	82
7.9.2	Setting the PROFIBUS address in “PROFIBUS ID”.....	83
7.9.3	Setting limit values in the “Limit” menu item.....	83
8	Shutdown	86
8.1	Technical knowledge necessary for shutdown	86
8.2	Safety information on shutting down	86
8.3	Preparations for shutdown	86
8.4	Switch-off procedure.....	86
8.5	Protective measures for shutdown device.....	86
8.5.1	Measures for short-term shutdown	86
8.6	Transport	87
8.7	Disposal	87

- 9 Maintenance..... 88**
 - 9.1 Necessary technical knowledge for maintenance work 88
 - 9.2 Safety instructions for maintenance work 88
 - 9.3 Maintenance 88
 - 9.3.1 VISIC50SF maintenance 88
 - 9.3.2 Maintenance plan 93
 - 9.3.3 Tunnel cleaning 93
 - 9.4 When requesting Customer Service from Endress+Hauser 93
 - 9.5 Spare parts 94
 - 9.5.1 Spare parts for VISIC50SF 94
 - 9.5.2 Spare parts for connection unit 94
 - 9.5.3 Spare parts for TAD control unit 94

- 10 Clearing malfunctions..... 95**
 - 10.1 Description of device errors 95
 - 10.2 Description of maintenance requests 96
 - 10.3 Display of error states on the control unit 96
 - 10.4 Further error causes 96

- 11 Specifications..... 97**
 - 11.1 Compliances 97
 - 11.1.1 Electrical protection 97
 - 11.1.2 Standards observed 97
 - 11.1.3 Declaration of Conformity 97
 - 11.2 Dimensions 98
 - 11.2.1 Dimension drawing VISIC50SF 98
 - 11.2.2 Dimension drawing, connection unit 99
 - 11.2.3 Dimension drawing TAD control unit 100
 - 11.2.4 Dimension drawing VISIC50SF ceiling mounting, not swivel-mounted 101
 - 11.2.5 Dimension drawing VISIC50SF ceiling mounting, swivel-mounted 101
 - 11.2.6 Drilling plan VISIC50SF 102
 - 11.2.7 Drilling plan connection unit 103
 - 11.2.8 Drilling plan TAD control unit 104
 - 11.2.9 Drilling plan mounting plate for ceiling mounting 105
 - 11.3 Technical data 106

1 Important information

1.1 About this document

- This Manual describes:
 - Device components
 - Installation
 - Operation
 - Maintenance work required
- It contains important safety information for safe operation.

1.2 Responsibility of user

- ▶ Read the Operating Instructions before putting the VISIC50SF into operation.
- ▶ Observe all safety information.
- ▶ If anything is not clear: Please contact Endress+Hauser Customer Service.

Designated users

The VISIC50SF may be operated by competent persons only who, based on their device-specific training and knowledge of the device as well as knowledge of the relevant regulations, can assess the tasks given and recognize the hazards involved.

Correct use

- This Manual presumes that the VISIC50SF has been delivered as specified during project planning and with the relevant delivery state of the VISIC50SF (→ delivered system documentation).
- If you are not sure whether the VISIC50SF complies with the planned configuration or the delivered System Documentation:
 - ▶ Please contact Endress+Hauser Customer Service.
- The VISIC50SF should only be used as described in these Operating Instructions, [see “Purpose of the device”, page 10](#). The manufacturer assumes no responsibility for any other use.
- Maintenance work should be performed as prescribed in this Manual.
- Do not attempt any work on or repairs to the VISIC50SF unless described in this Manual.
- Do not modify the VISIC50SF in any way unless specifically instructed and permitted to do so by the manufacturer.
- Use only original spare parts and wear and tear parts from Endress+Hauser.

If not observed:

- Any warranty of the manufacturer is void.
- The VISIC50SF can become dangerous.

Special local conditions

- ▶ Follow all local laws, regulations, and company policies applicable at the mounting location.

Retention of document

These Operating Instructions:

- Must be available for reference.
- Must be conveyed to new owners.

1.3 Intended use

1.3.1 Purpose of the device

The VISIC50SF is designed for quick and secure detection of smoke in tunnels.

1.3.2 Product identification

Product name:	VISIC50SF
Manufacturer:	Endress+Hauser SICK GmbH+Co. KG Bergener Ring 27 · 01458 Ottendorf-Okrilla · Germany

The type plate is located on the side on the rear enclosure panel.

1.3.3 Mounting location

- In the tunnel for smoke detection
- On tunnel portals
- In basement garages
- Generally for smoke detection in applications similar to tunnels

2 Product description

2.1 Features of the VISIC50SF

- ▶ Simultaneous or individual measurement of
 - a) Standard:
 - Visibility (K-value) for smoke detection
 - b) Optional
 - Temperature of ambient air
- ▶ Measuring visibility with fog dissipation (optional).
- ▶ Compact design with low space requirements.
- ▶ Already calibrated ex factory, no readjustment required onsite (Plug & Measure).
- ▶ Scope of delivery with or without connection unit.
- ▶ Scope of delivery with or without TAD control unit.
- ▶ Keypad and single-line display in the measuring unit to
 - Display values when the device is open.
 - Control diagnosis and maintenance.
 - Assign device addresses when using bus wiring.
 - Configure alarm thresholds.
- ▶ Status LED signals error-free operation (green), maintenance request (yellow) and malfunction (red).
- ▶ Standard: 2 analog outputs and 3 digital outputs, 1 x Modbus-RTU.
- ▶ Optional: PROFIBUS DP-V0.

Fig. 1: Application example VISIC50SF

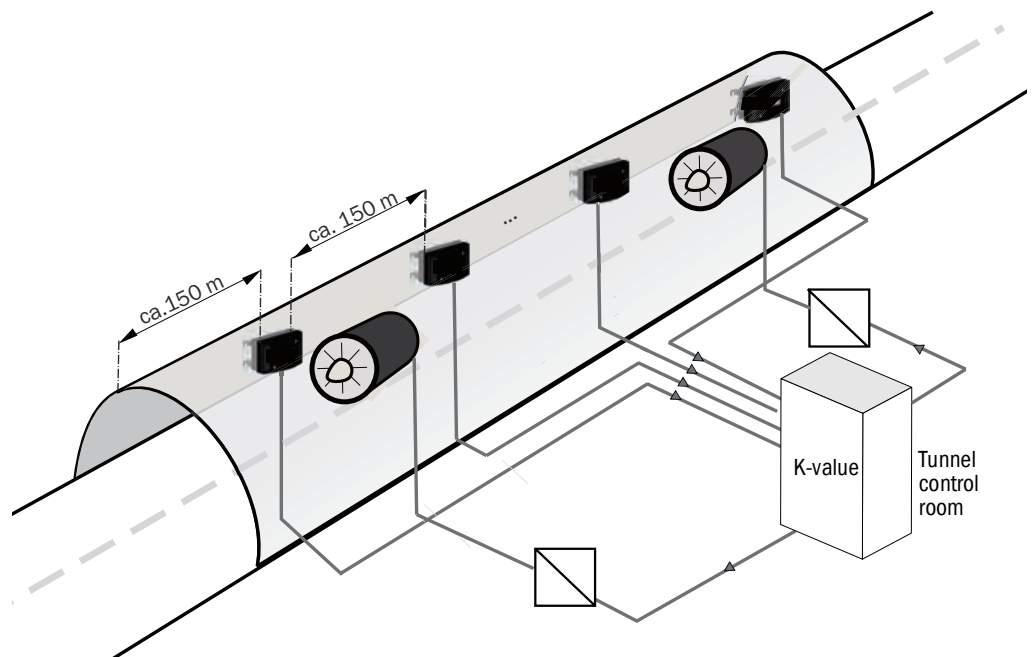

- Option:
- Connection unit and/or control unit TAD
 - Fog dissipation: Version with heating

2.2 Device versions

2.2.1 Standard components: VISIC50SF visibility measurement (K-value)

Fig. 2: VISIC50SF sensor

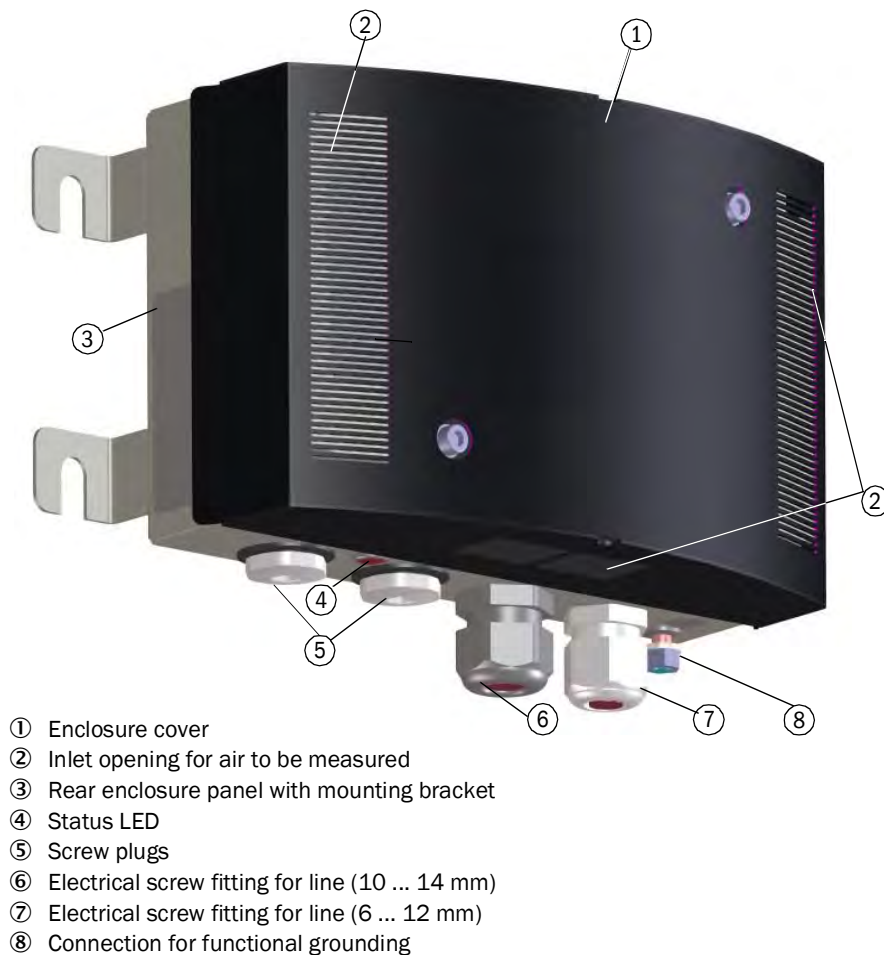

2.2.2 Optional equipment

2.2.2.1 Temperature measurement PT1000

Fig. 3: Temperature sensor PT1000

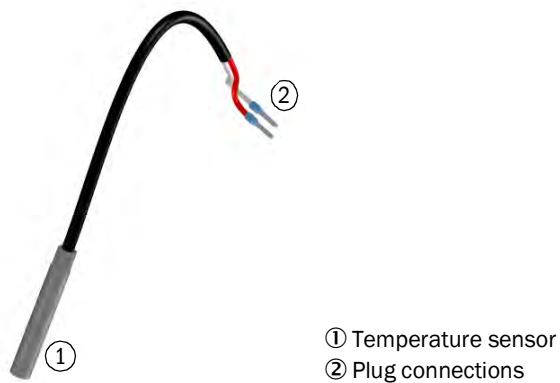

2.2.2.2 Connection unit

2 variants:

- TB-A1: Connection unit for reconnection of cables. It contains:
 - 10 terminals to connect cables provided by the customer.
- TB-A2: Connection unit to connect the VISIC50SF to the power voltage. It contains:
 - Power supply filter, terminals and a power supply unit.



Specifications concerning stub lines see [“Stub line lengths for connection unit on all RS-485 bus systems”](#), page 48 must always be adhered to when the VISIC50SF and the associated connection unit are part of a bus system.

Fig. 4: Connection unit with 24 V power supply for the sensor



- ① Enclosure cover
- ② Rear enclosure panel with mounting bracket
- ③ Electrical screw fittings for cables:
 - 3 x 6 ... 11 mm
 - 2 x 10 ... 14 mm
- ④ Grounding



Ready-made connection cables are available for both variants. (Further details on connection cables, see [“Installation material”](#), page 21)

2.2.2.3 Control unit TAD

2 variants:

- TAD100 standard control unit
- TAD100 control unit with optional I/Os

Fig. 5: TAD control unit



- ① Enclosure cover
- ② Display unit
- ③ Screw fittings for the cables
 - 4 x 6 ... 12 mm (M20 x 1.5)
- ④ - 1 x 5 ... 10 mm (M16 x 1.5)

2.2.2.4 Fog dissipation (cover with integrated heating element)

Endress+Hauser provides a variant with a heating element in the cover for fog dissipation.

Fig. 6: VISIC50SF cover with heating element for fog dissipation

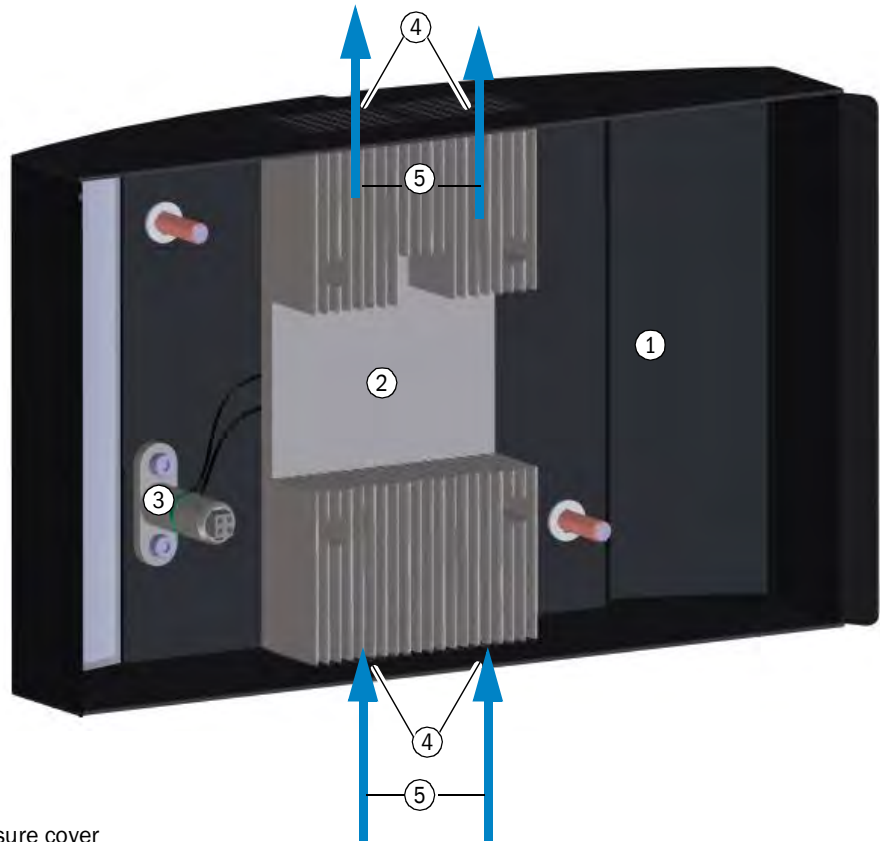

- ① Enclosure cover
- ② Heating element
- ③ Electrical contacts for heating element
- ④ Inlet opening for air to be measured
- ⑤ Flow direction of air to be measured

+i The heating element is integrated in the VISIC50SF cover and cannot be retrofitted onsite.

+i The side openings for the air to be measured are closed off on the VISIC50SF version with fog dissipation.

+i If the cover is not placed on the measuring unit, error message F004 (heating) is active because the power supply to the heating is interrupted.

2.2.2.5 Bus interface: PROFIBUS DP-V0, Modbus-RTU

The VISIC50SF is delivered with the following bus interface depending on the configuration:

- Modbus-RTU (standard)
- PROFIBUS DP-V0 (option)

+i Modbus-RTU is not available when a control unit is used.

2.2.3 Measuring principle

- Visibility: Scattered light measurement
- Temperature: Resistance measurement

2.2.4 Interior view of the VISIC50SF

Fig. 7: Interior view - enclosure, complete

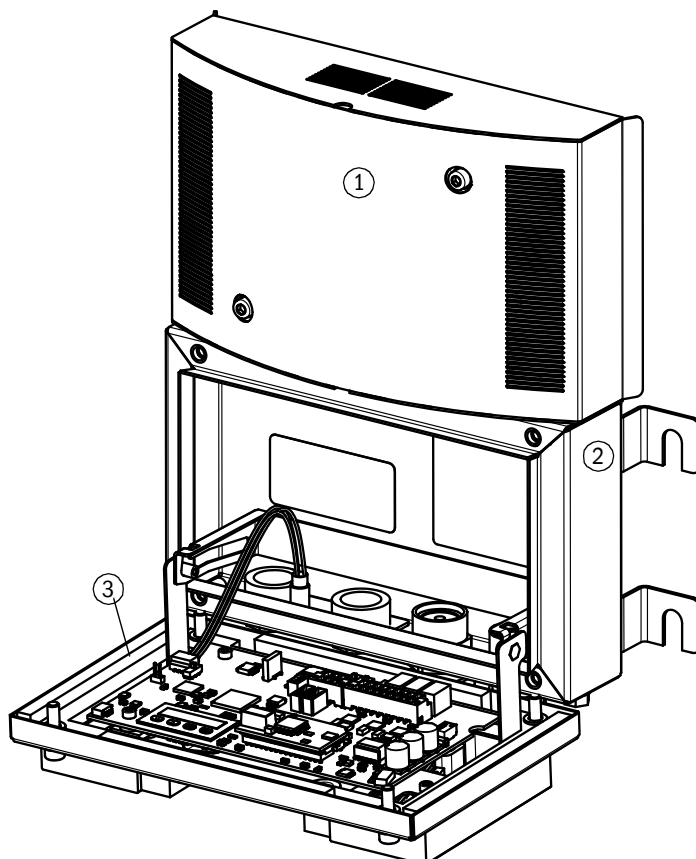

- ① Enclosure cover
- ② Rear enclosure panel with mounting bracket
- ③ Measuring unit



The enclosure cover can be held on the rear enclosure panel for maintenance purposes.

Fig. 8: Interior view - enclosure cover without heating

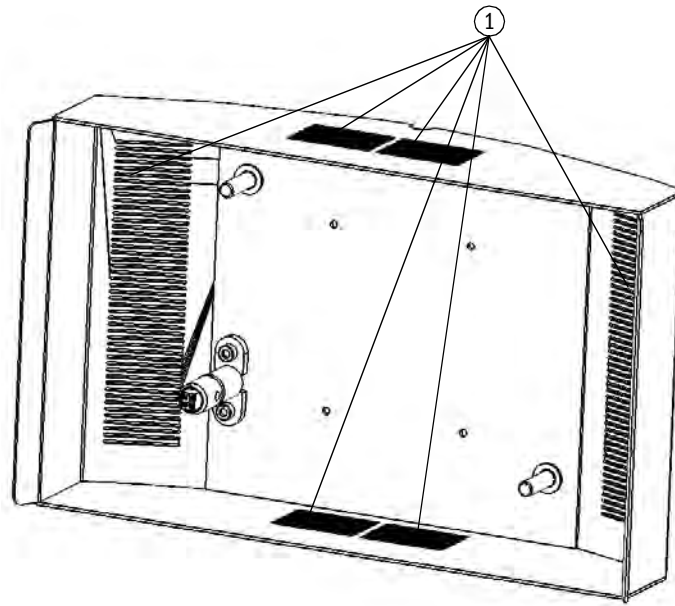

① Inlet opening for air to be measured

Interior view - enclosure cover with heating

see “VISIC50SF cover with heating element for fog dissipation”, page 15.

Interior view - measuring unit

Fig. 9: Measuring unit - mainboard with display and keypad

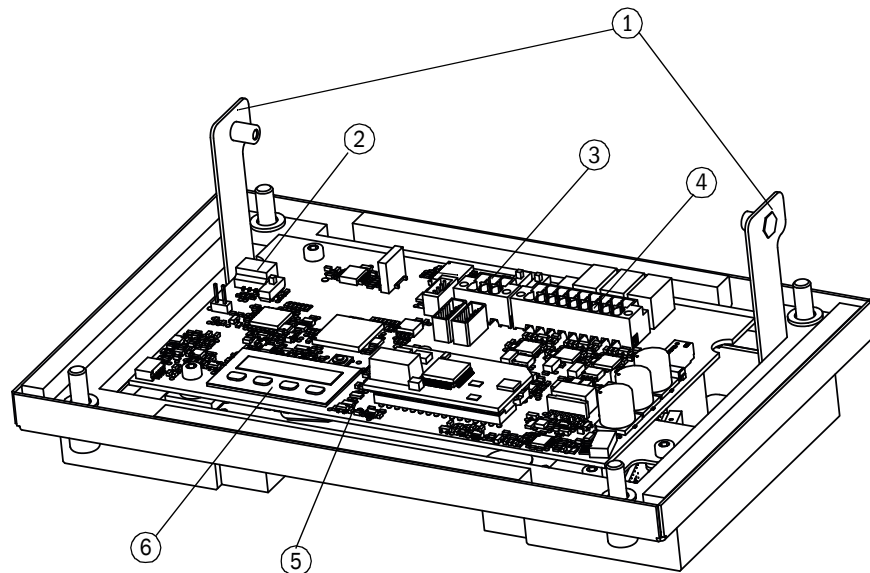

- ① Hinge fixture
- ② Slot for Status LED
- ③ Wiring block for bus connections (RS-485)
- ④ Wiring block for 24 V and signals
- ⑤ Reset button
- ⑥ Display with keypad

Fig. 10: Measuring unit

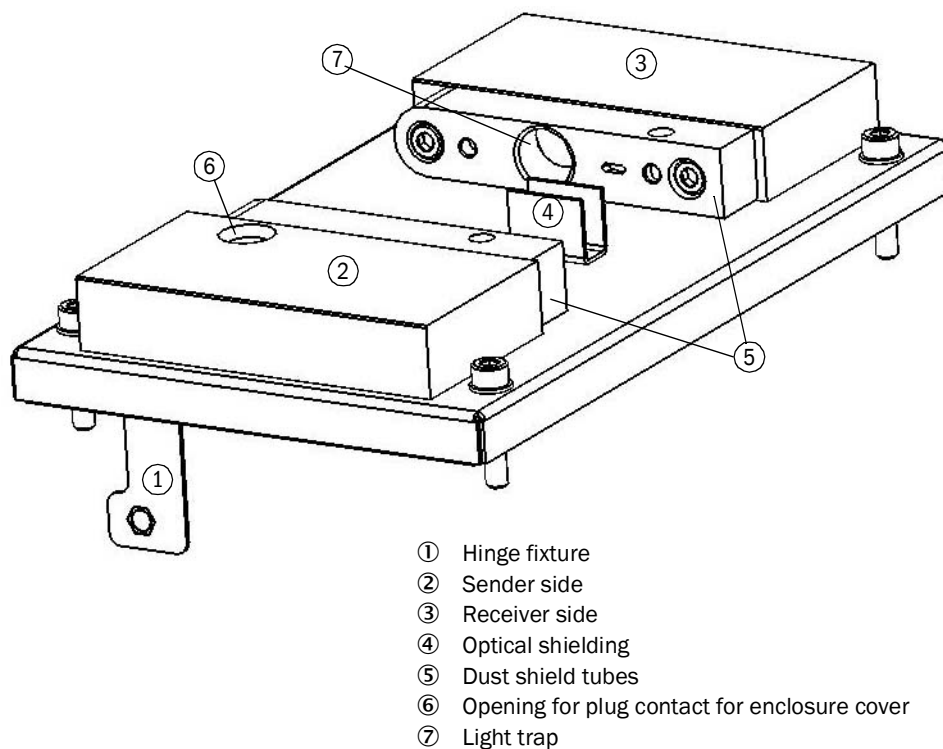
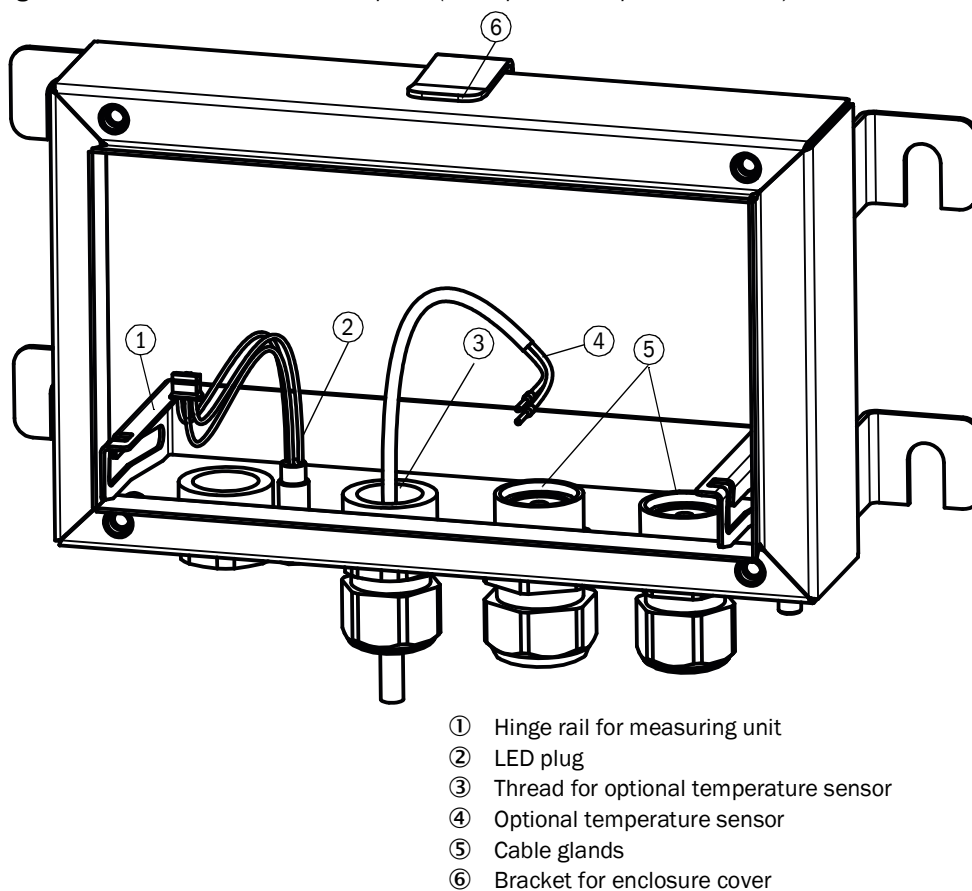

Fig. 11: Interior view - rear enclosure panel (with optional temperature sensor)



2.3 Interfaces

Standard:

- 2 analog interfaces for measured value output
- 3 digital interfaces for malfunction, maintenance requirement and limit value exceeded
- Alternatively: 3 digital interfaces for malfunction, exceeding pre-alarm, and exceeding main alarm
- RS-485: Either Modbus-RTU or Endress+Hauser bus to the TAD control unit

Optional:

- PROFIBUS DP-VO

2.3.1 Analog interfaces characteristics

The interfaces of the VISIC50SF provide 4 ... 20 mA signals. If an error exists on the VISIC50SF, the relevant analog output changes to 1 mA.



The switch to 1 mA only affects the analog output with a device error. The other analog output continues to output a measured value between 4 ... 20 mA.



The analog interface can deliver a load of up to 500 Ohm. The refresh rate is ≤ 1.6 seconds.

The following formulas show the relation between the output current and the respective measured variable:

Visibility:

$$\text{Measured variable (visibility)} = \frac{(\text{Output current} - 4\text{mA})}{16} \times \text{full-scale value}$$

Temperature:

$$\text{Measured value (temperature)} = \frac{(\text{Output current} - 4\text{mA})}{16} * 100 - 30$$

2.3.2 Digital interfaces properties

If a device error is detected, an error is signaled via the malfunction relay. If no device error exists, the malfunction relay is in a closed state. The relay opens when an error occurs.

2.3.3 Modbus-RTU interface characteristics

More information in Section Commissioning, see [“Modbus-RTU \(integrated in the VISIC50SF standard version\)”](#), page 40.

3 Mounting and electrical installation

3.1 Safety information

**NOTICE: Preventive measures for operating safety**

The VISIC50SF is normally used together with control technology.

- ▶ Should a malfunction occur on the VISIC50SF, ensure this cannot lead to conditions dangerous for traffic or can hinder traffic.

**NOTICE: The system operator is responsible for the operating safety of the device when integrated in a system**

- ▶ Observe the connection values in Section, see [“Technical data”, page 106](#), when integrating the device in a system.
-

**WARNING: Preventive measures during mounting and installation**

- ▶ Observe the generally applicable regulations for protective clothes in tunnels.
 - ▶ Observe the regulations for personal safety (e.g., lane closure, warning devices).
-



NOTICE: Mounting of the VISIC50SF may be carried out by competent persons only who, based on their device-specific training and knowledge of the device as well as knowledge of the relevant regulations, can assess the tasks given and recognize the hazards involved.



NOTICE: Endress+Hauser original mounting material is recommended for safe mounting of the VISIC50SF.

**CAUTION: The connection unit and the control unit do not have independent main power switches.**

- ▶ In accordance with EN 61010, the following must be ensured before installation:
 - A main power switch is available in the tunnel.
 - Service personnel can easily access the main power switch.
 - The main power switch is marked as disconnecting device.
-

3.2 Material required

Table 1: Mounting material

Material required	Part number	Required for
Fixing set	2071034	VISIC50SF, connection unit or control unit
Drilling plan Drilling template		see "Drilling plan VISIC50SF (all units of measurement in mm)", page 102.
Bracket for under-ceiling mounting 1.4571	2075713	see "Maximum permissible angle for rigid mounting on the ceiling (all dimensions in mm)", page 23
Bracket for under-ceiling mounting 1.4529	2076795	
Swivel bracket 1.4571	2075525	see "Maximum permissible angle for swivel-mounted ceiling mounting (all dimensions in mm)", page 23
Swivel bracket 1.4529	2076796	

Table 2: Installation material

Material required	Part number	Required for
Cable, 2 m (12 x 0.75 mm ²)	2076476	Analog cables for connection of VISIC100SF - connection unit or control unit
Cable, 5 m (12 x 0.75 mm ²)	2076477	
Cable, 10 m (12 x 0.75 mm ²)	2076478	
Cable, 20 m (12 x 0.75 mm ²)	2076479	
Onsite cables		Robust material, suitable for outdoor applications, halogen-free, shielded; Wires: 12 x 0.75 mm ² ; Connection of VISIC50SF on connection unit, control unit or tunnel control room
Cable, 2 m (3 x 2 0.75 mm ²)	2076481	Cables for RS-485 interface
Cable, 5 m (3 x 0.75 mm ²)	2076482	
Cable, 10 m (3 x 0.75 mm ²)	2076483	
Cable, 20 m (3 x 0.75 mm ²)	2076484	
Ferrules Length: Min. 10 mm; Max. 20 mm		For onsite cables To prepare flexible leads. Note: Delivered in enclosure.

Table 3: Tools

Tools required	Characteristics	Required for
Hammer drill	Masonry drill, ø 8 mm	Drill holes
Hammer		Hammer in the steel tie bar
Allen key	SW4	Opening the cover of the measuring unit
Wrench	SW13 SW10	Fastening nut of steel tie bar Grounding bolts
Flat-blade screwdriver	Max. 3 mm	Cable installation
Ferrule pliers		For onsite cables



Observe the country-specific tunnel regulations for mounting material. Suitable ferrules are made available as standard. These are not required for cables from Endress+Hauser.

3.3 Preparing the mounting location

- ▶ Secure the place of work
- ▶ Provide sufficient light, power and, when necessary, a lifting platform at the place of work.

Keep fixing material available as well as suitable drills, cables, socket wrench set, marking material, measurement tools.



- ▶ **Setting the inclination angle:** see “Maximum permissible angle of inclination and mounting location height for wall fitting”, page 22 and see “Min. distance to the ceiling for mounting on the wall”, page 24.

3.4 Mounting

3.4.1 Scope of delivery

- ▶ Check the scope of delivery against the order and delivery documents.

3.4.2 Mounting the VISIC50SF

- 1 Determine the sensor mounting location according to the project planning.
 - a) Wall fitting

Fig. 12: Maximum permissible angle of inclination and mounting location height for wall fitting

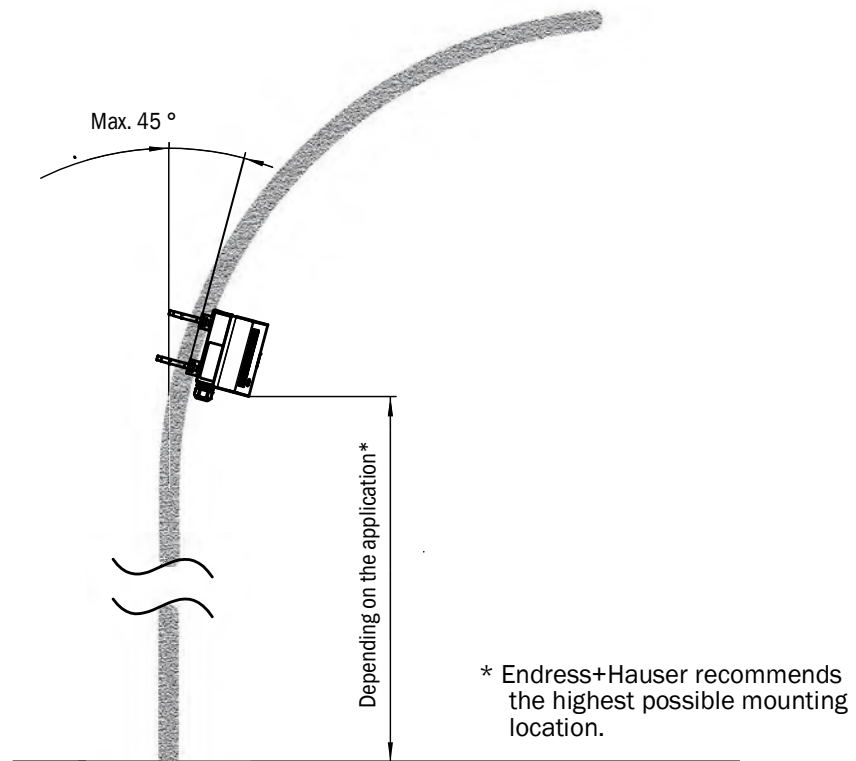

b) Mounting on the ceiling with fixed angle

Fig. 13: Maximum permissible angle for rigid mounting on the ceiling (all dimensions in mm)

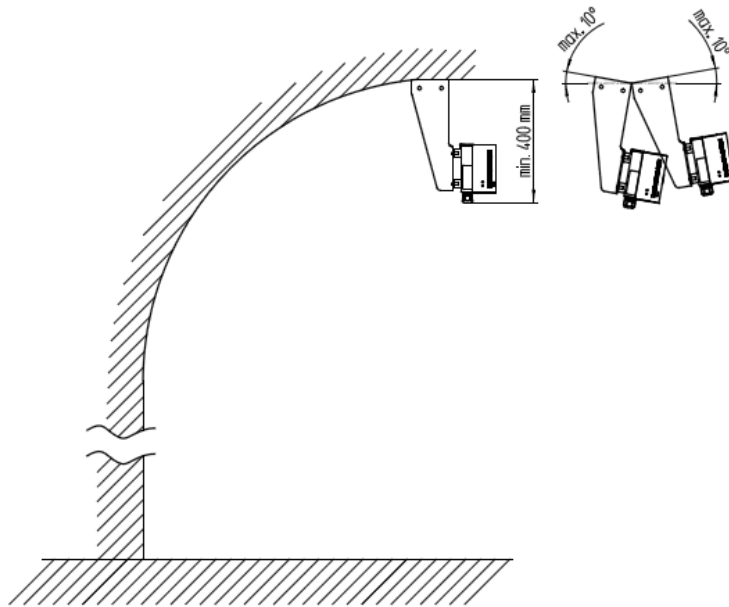

c) Mounting on the ceiling with adjustable mounting angle

Fig. 14: Maximum permissible angle for swivel-mounted ceiling mounting (all dimensions in mm)

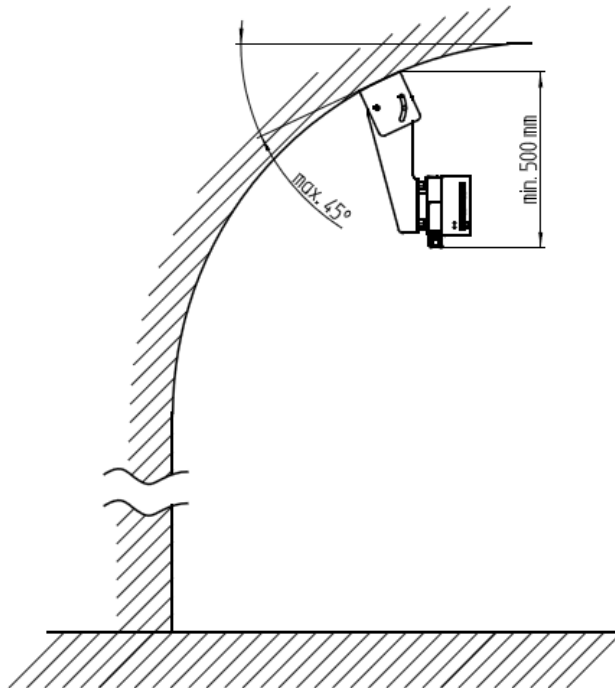

Fig. 15: Min. distance to the ceiling for mounting on the wall

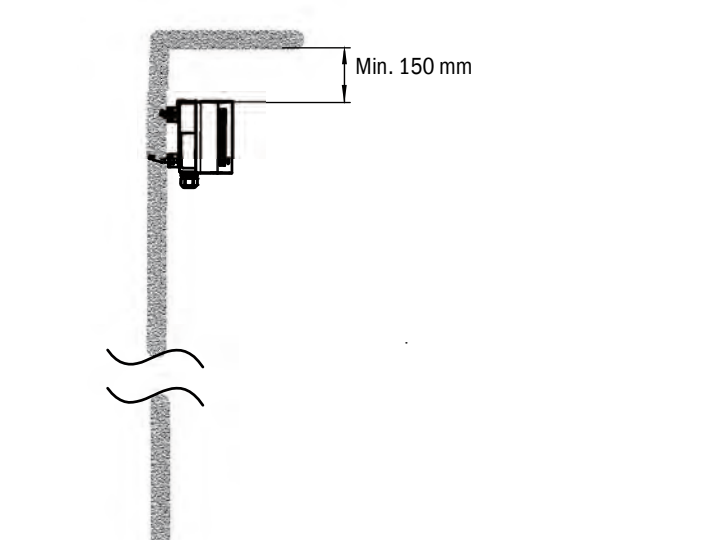
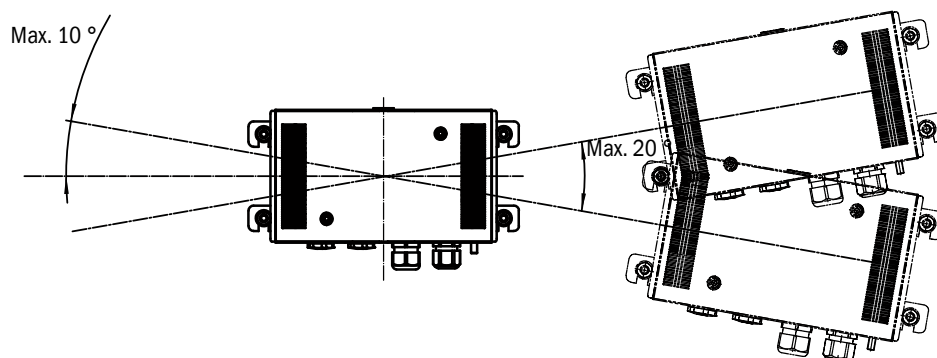

Fig. 16: Maximum permissible angle of rotation of the mounted VISIC50SF



Use a wall plate when the installation walls are extremely uneven. Consider this special solution during project planning.

- 2 Execute drilling for the VISIC50SF wall bracket as shown in the VISIC50SF drilling plan, see [“Drilling plan VISIC50SF \(all units of measurement in mm\)”](#), page 102.
- 3 Hammer in the M8 steel tie bar (from fixing set).

Fig. 17: Mounting - rear enclosure panel

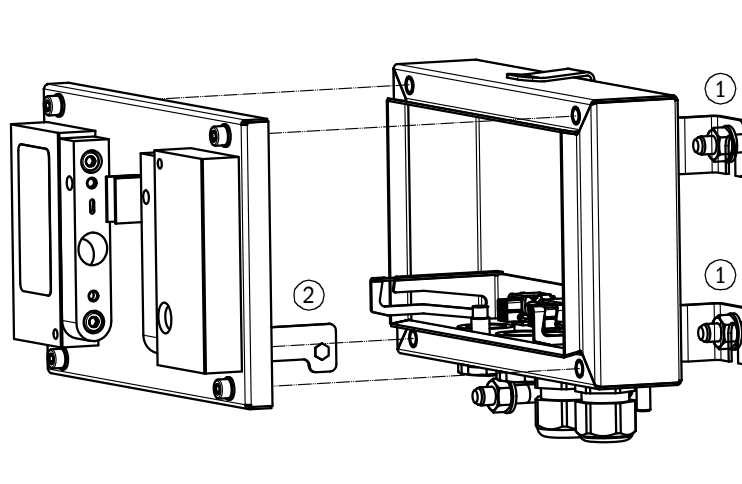

- ① Mounting bracket
- ② Hinge fixture for the measuring unit

- 4 Fit the rear enclosure panel.
- 5 Hinge the measuring unit in.
- 6 Wiring, see [“Wiring of VISIC50SF”, page 29](#).
- 7 Commissioning, see [“Commissioning”, page 38](#).
- 8 Screw the measuring unit on.
- 9 Fit the enclosure cover.

Information for loosening the enclosure cover:



After loosening the two screws, removing the enclosure cover could be somewhat sluggish. Therefore, the enclosure cover side panels are extended on the sides and serve as handles.



If the enclosure cover was placed on the measuring unit while the VISIC50SF was open, it can be easily removed by pressing the loosened screws against the measuring unit.



Carefully open the measuring unit. The cable connections can cause the hinge fixture to unhook out of the hinge rail.

3.4.3 Mounting the connection unit (optional)

Two connection unit versions:

Fig. 18: Connection unit TB-A1 for reconnection of cables

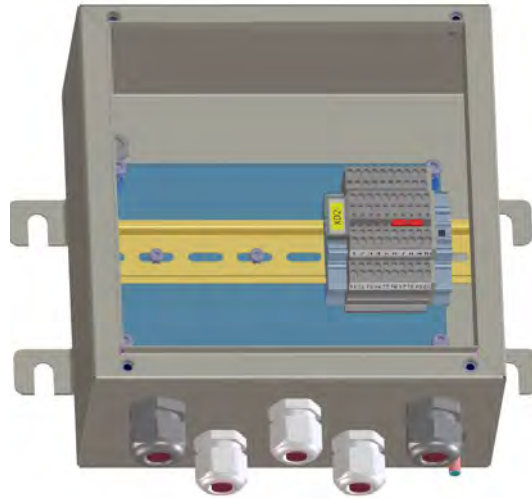

- Connection unit to reconnect cables provided (e.g. rigid to flexible cable, or cross-section adaptation).

Fig. 19: Connection unit TB-A2 with 24 V voltage supply unit and reconnection

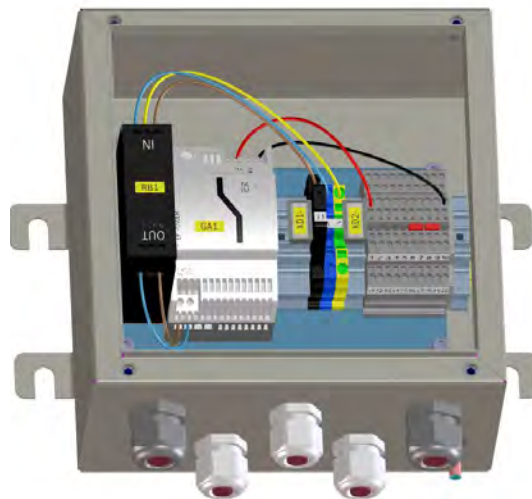

- Connection unit with power supply unit and power supply filter
- Connection unit to reconnect cables provided.

Material required for mounting and installation of the connection unit

Material and drilling plan are identical to the VISIC50SF sensor, see [“Mounting material”, page 21](#) and see [“Drilling plan VISIC50SF”, page 102](#).

Mounting the connection unit

- 1 Determine the connection unit mounting location according to the project planning.
- 2 Drill holes for the connection unit as shown in the drilling plan, see [“Drilling plan VISIC50SF”, page 102](#).
- 3 Hammer in the M8 steel tie bar (from fixing set).
- 4 Mount the connection unit.
- 5 Wiring, see [“Connection unit wiring”, page 34](#).
- 6 Screw the cover on.

3.4.4 Mounting the TAD control unit (optional)

- 1 Determine the control unit mounting location according to the project planning. Control unit dimensions, see “Dimensions TAD control unit (all units of measurement in mm)”, page 100.



With a separate power supply, the control unit can be mounted at a distance of max. 1200 m to the mounting location of the VISIC50SF.

- 2 Drill holes for the control unit as shown in the drilling plan, see “Drilling plan for TAD control unit for VISIC50SF (all units of measurement in mm)”, page 104.
- 3 Hammer in the M8 steel tie bar (from fixing set).
- 4 Fit the control unit.
- 5 Wiring, see “TAD control unit wiring”, page 35.

3.4.5 Mounting of temperature sensor PT1000 (optional)

Material required	Characteristics	Required for
Temperature sensor set	Part No. 2074831	Temperature measurement
Wrench	SW24	When using the cable gland included in the temperature sensor set
Allen key	SW8	Removing the VISIC50SF seal screw connection

- 1 Check the temperature sensor set for completeness.
- 2 Use the SW 8 Allen key to remove the black screw plug on the underside of the enclosure.

Fig. 20: Screw plugs for temperature sensor

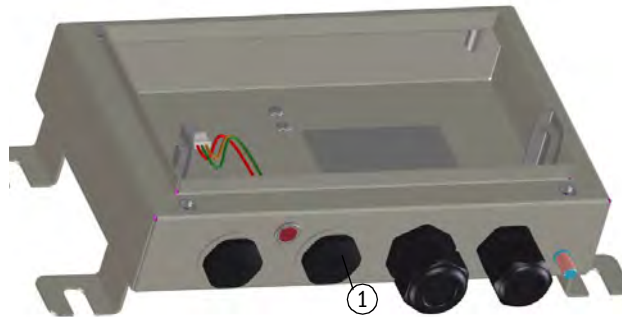

① Screw plugs for temperature sensors

- 3 Screw in the cable gland with O-ring included in the set.
- 4 Insert the temperature sensor into the cable gland.
- 5 Tighten the cable gland with an SW 24 wrench.

Fig. 21: Mounting of temperature sensor PT1000



6 Plug the sensor cable into the terminal strip on the main board, see Fig.22 for illustration.

Fig. 22: Electrical connection - temperature sensor PT1000

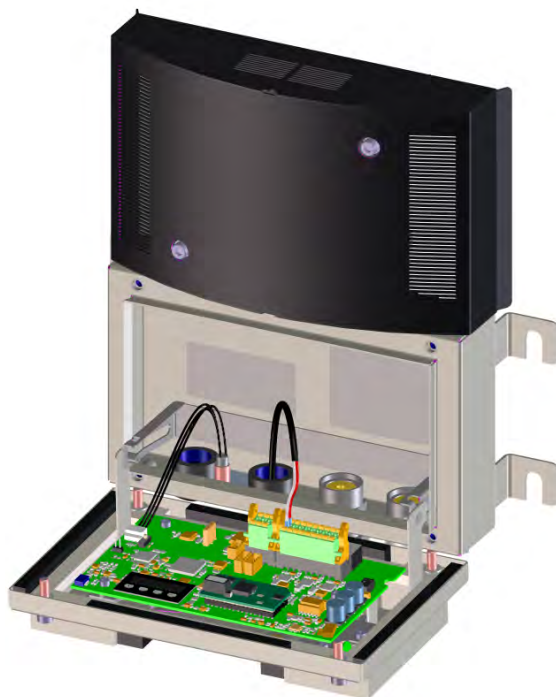

- 7 Close the device:
- ▶ Tip the measuring unit up and fasten it with the 4 screws.
 - ▶ Position the enclosure cover on the front side of the device.
 - ▶ Screw the two screws on the enclosure cover with the SW4 Allen key.

3.5 Wiring of VISIC50SF

3.5.1 Safety information



WARNING: Hazard by voltage.

- ▶ Only allow an authorized electrician to work on the electric system.
- ▶ Observe the relevant safety regulations during all installation work.
- ▶ Take suitable protective measures against local risks and those arising from the plant.



NOTICE: Onsite electrical installation is the responsibility of the operator.

Provide separate external main power switches which disconnect all connectors, and fuses in the proximity of the VISIC50SF (max. power input of the VISIC50SF

→ Technical data)



NOTICE: Device damage through electrostatic discharges

The VISIC50SF may be connected only by an expert.

- ▶ Observe the applicable ESD Guidelines.



NOTICE: Avoid damage to the electronics

Before signal connections are established (also with plug connections):

- ▶ VISIC50SF, separate the connection unit and/or control unit from the mains.



The connection unit and/or control unit do not have independent main power switches. In accordance with EN 61010, the following must be ensured before installation:

- A main power switch is available in the tunnel.
- Service personnel can easily access the main power switch.
- The main power switch is marked as disconnecting device.

3.5.2 Connecting the LED

Fig. 23: Slot for Status LED cable



Fig. 24: LED switch position on the mainboard

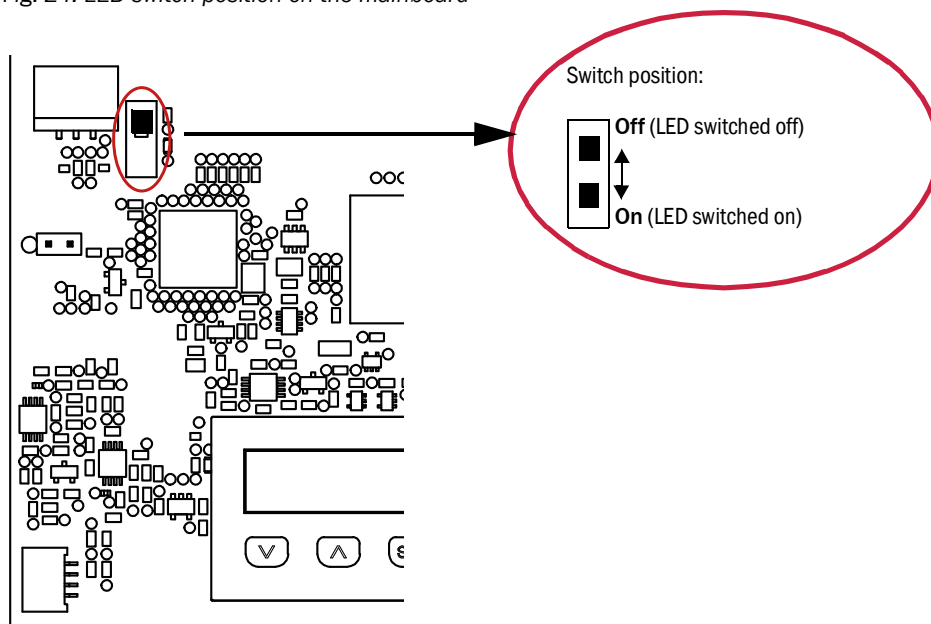

Fig. 25: Grounding connection on VISIC50SF



① Connection to fasten the functional grounding

3.5.3 Wiring of analog outputs, relay outputs and voltage supply

Fig. 26: Wiring plan for analog outputs, relay outputs and voltage supply

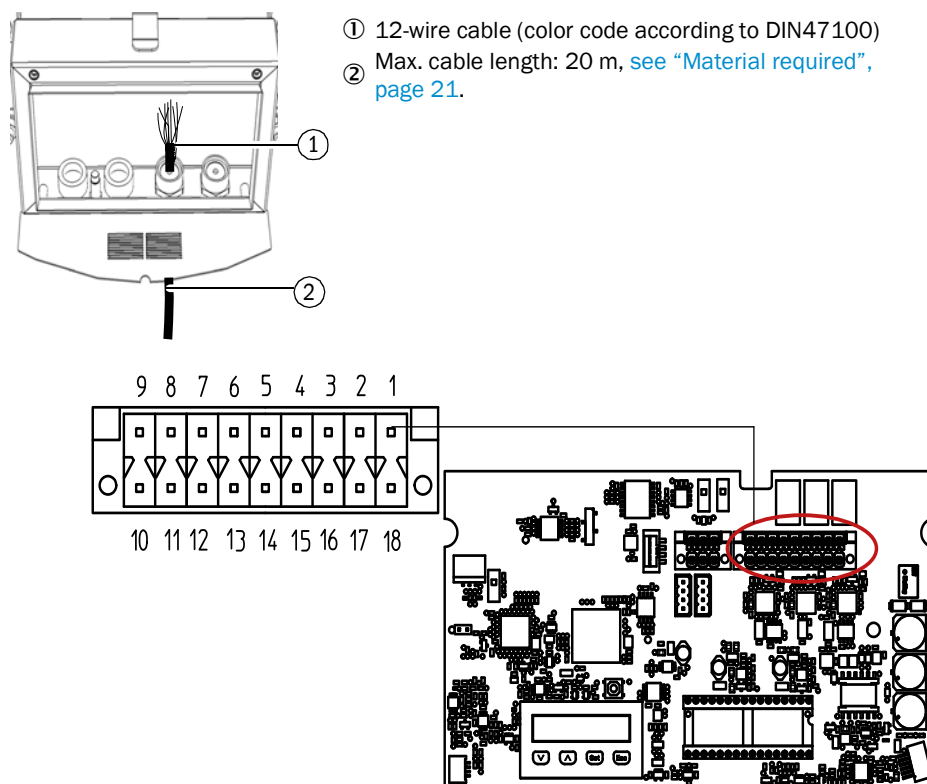

- ① 12-wire cable (color code according to DIN47100)
- ② Max. cable length: 20 m, see “Material required”, page 21.

Table 4: Terminal assignment VISIC50SF

Terminal	Voltage supply	Terminal	Analog outputs (4 ... 20 mA)
1	+24 V DC	5	+ visibility
18	Ground (GND)	14	- visibility
	Digital outputs	6	+ temperature
2	Maintenance Request Common	13	- temperature
17	Maintenance Request Normally Open		Analog inputs
3	Malfunction Common	9	PT1000-A (temperature)
16	Malfunction Normally Closed	10	PT1000-B (temperature)
4	Limit Value Common		
15	Limit Value Normally Open		



The PT1000 can be connected to the analog input independent of the polarity.

3.5.4 Bus interface wiring

Fig. 27: Wiring plan for RS-485 interface

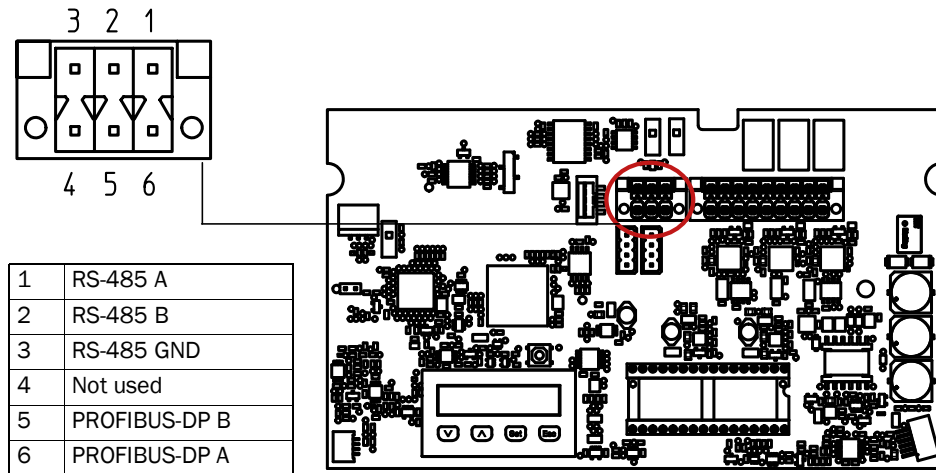

+i The RS-485 interface can be used for the Modbus or the control unit (optional).

3.5.5 Shielding

The shield must be grounded at both ends to ensure effective shielding against high-frequency interference. Especially on installations located away from each other, potential differences can occur and therefore lead to potential equalization currents along a cable shield. Such equalization currents on a cable shield must be avoided at all costs because these can lead to interference signals. Contacting the shield with the brushes of the cable gland, see [“Shielding in VISIC50SF”, page 32.](#)

Fig. 28: Shielding in VISIC50SF

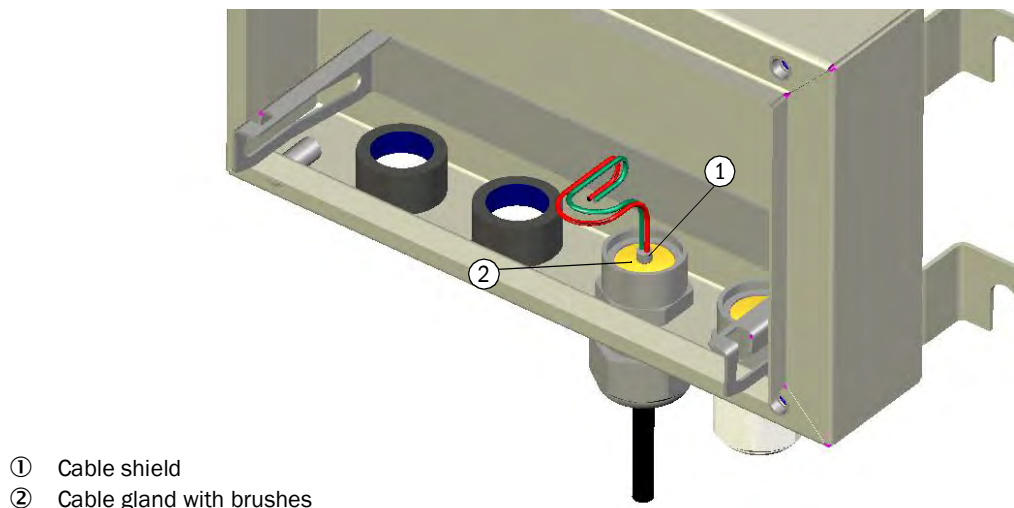

To prevent potential differences between individual system components, all devices on the bus must have the same potential. To achieve this, all devices must be connected to each other with a potential equalization conductor (see “Potential equalization cable”, page 33).



CAUTION: Never use the cable shield as potential equalization

The cable shield only serves to shield against high-frequency interference and may not be used as potential equalization.

Fig. 29: Potential equalization cable

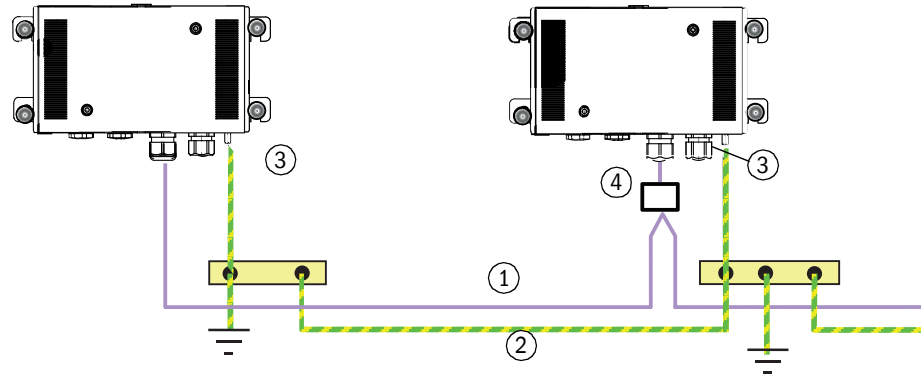

- ① Signal cable
- ② Potential equalization cable
- ③ Ground cable connection
- ④ T-connector or connection unit

3.5.6 Connection unit wiring

Table 5: Connection unit voltage supply

PE	
N	85 ... 264 V AC
L	45 ... 65 Hz

Table 6: Wiring Table of connection unit

Terminal	VISIC50SF analog	VISIC50SF system bus
1	+24 V DC	+24 V DC
2	+24 V DC	+24 V DC
3	Ground (GND)	Ground (GND)
4	Ground (GND)	Ground (GND)
5	Maintenance Request Common	RS-485 A ^[1]
6	Maintenance Request Normally Open	RS-485 A ^[1]
7	Malfunction Common	RS-485 B ^[1]
8	Malfunction Normally Closed	RS-485 B ^[1]
9	Limit Value Common	RS-485 GND ^[1]
10	Limit Value Normally Open	RS-485 GND ^[1]
11	+ visibility	PROFIBUS-DP A ^[2]
12	- visibility	PROFIBUS-DP A ^[2]
13	+ temperature	PROFIBUS-DP B ^[2]
14	- temperature	PROFIBUS-DP B ^[2]
15	PT1000-A (temperature input)	PT1000-A (temperature input)
16	PT1000-B (temperature input)	PT1000-B (temperature input)
17, 18, 19, 20	Not used	

[1]When connected via RS-485, terminals 5 + 6, 7 + 8 and 9 + 10 must be connected with a jumper.

[2]When connected via PROFIBUS, terminals 11 + 12 and 13 + 14 must be connected with a jumper.

3.5.7 TAD control unit wiring

Table 7: TAD control unit power supply

PE	
N	88 ... 264 V AC
L	47 ... 63 Hz

Table 8: TAD control unit Wiring Table

Terminal	Control unit without I/O modules	Control unit with I/O modules [1]
1	+ 24 V DC	
2	+ 24 V DC	
3	+ 24 V DC	
4		
5	Ground (GND)	
6	Ground (GND)	
7	Ground (GND)	
8		
9	RS-485-A	
10	RS-485-A	
11		
12	RS-485 B	
13	RS-485 B	
14	RS-485 GND	
15	- visibility	
16		
17		
18	- temperature	
19	+ visibility	
20		
21		
22	+ temperature	
23	Maintenance Request Normally Open	
24	Maintenance Request Common	
25	Malfunction Normally Closed	
26	Malfunction Common	
27		
28		
29	Limit Value Common	
30	Limit Value Normally Open	

[1]On request



When using a TAD100 Standard control unit, it is possible to wire the Profibus interface of the sensor. Two or four terminals 15 to 30 can be used for this purpose.



The AO is set to 1 mA when the communication between VISIC50SF and control unit is aborted. The DO module remains in the current state until new data are transferred.

3.6 Connections

3.6.1 Standard version

Fig. 30: VISIC50SF connections

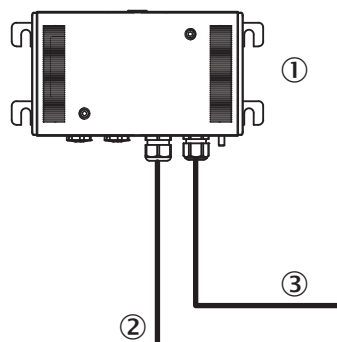

- ① Sensor unit VISIC50SF
- ② Power supply (24 V)
- ③ Analog and digital signals or data bus

3.6.2 VISIC50SF with connection unit

Fig. 31: VISIC50SF connections with connection unit

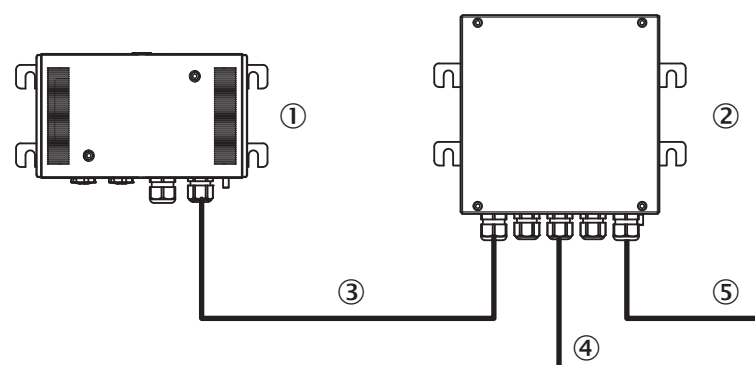

- ① Sensor unit VISIC50SF
- ② Connection unit
- ③ Analog and digital signals or data bus (max. length = 1200 m)
- ④ Power supply (230 V)
- ⑤ Analog and digital signals or data bus

3.6.3 VISIC50SF with TAD control unit

Fig. 32: VISIC50SF connections with TAD control unit

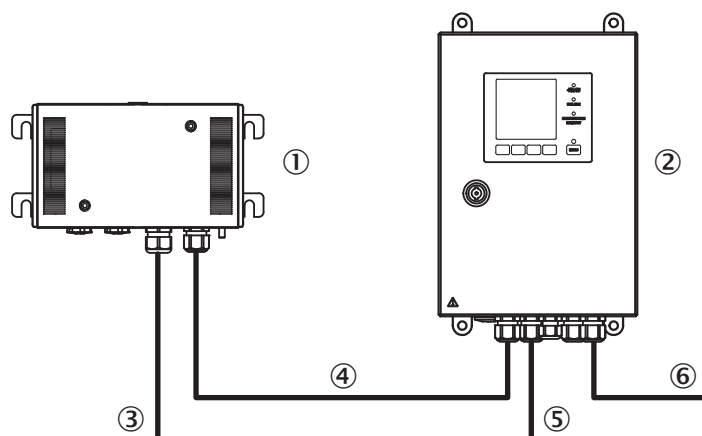

- ① Sensor unit VISIC50SF
- ② TAD control unit
- ③ Power supply (24 V)
- ④ Analog and digital signals or data bus (max. length = 1200 m)
- ⑤ Power supply (230 V)
- ⑥ Analog and digital signals or data bus

4 Commissioning

Overview of commissioning tasks

- Check wiring of VISIC50SF components.
- Check and switch on voltage supply.
- Check Status LED.
- Check measured value plausibility.
- Hardware test.



Tools required for commissioning, see [“Tools”, page 21](#)

4.1 Commissioning, step by step

1. Separate voltage supply.
2. Check for correct mounting before commissioning.
3. Using the Allen key, open the enclosure cover, take the cover off and insert it in the fixture provided.
4. Loosen the four screws of the measuring unit with the SW4 hex key and swivel the measuring unit down.
5. Check wiring.
 - » For VISIC50SF: see [“Wiring of analog outputs, relay outputs and voltage supply”, page 31](#).
 - » Connection unit, see [“Connection unit wiring”, page 34](#).
 - » TAD control unit, see [“TAD control unit wiring”, page 35](#).
6. Connect Status LED cable to circuit board slot.
7. Contact plug for voltage supply.
8. Install and connect the optional temperature sensor, see [“Mounting of temperature sensor PT1000 \(optional\)”, page 27](#).
9. Switch the voltage supply on.
10. Plausibility check on measured values and device status.
 - ▶ If the measured values shown on the display are implausible, check enclosure for coarse contamination and clean as necessary.
11. Perform hardware test:
 - ▶ Set the device to Maintenance mode (“Maint”) using the keypad. Refer to Section “Menu”, see [“Calling up maintenance request and malfunction messages with menu item “Status”, page 54](#) for further information.
 - ▶ Set the current levels of analog outputs and digital outputs (maintenance request/ malfunction). Refer to Section “Menu”, see [“Testing the analog output for the K-value with menu item “k”, page 60](#) and see [“Testing the “Maintenance request” relay with menu item “MRq”, page 61](#) for further information
12. Deactivate Maintenance mode. Refer to Section “Menu”, see [“Activating maintenance in menu item “Maint”, page 54](#) for further information.

13. Close the device:
 - ▶ Tip measuring unit up.
 - ▶ Screw the four screws with the SW4 Allen key.
 - ▶ Position the enclosure cover on the front side of the device.
 - ▶ Screw the two screws on the enclosure cover with the SW4 Allen key.
14. Visual check: Status LED should be green. The following reasons can cause the Status LED not to be green:
 - LED switch on the main board has been switched off. (Factory setting: LED switch is set to "On") Figure of Switch, [see "LED switch position on the mainboard", page 30](#).
 - Enclosure cover not fitted (Status LED red).
 - Check the plug on the main board when the Status LED is not on.
 - Active maintenance and malfunction states. To retrieve the maintenance request and malfunction messages as well as malfunction and maintenance request Code Tables, [see "Device error coding", page 95](#) and [see "Description of maintenance requests", page 96](#).

4.2 Bus connections

There is the option to output the VIS and temperature value digitally via Modbus-RTU (standard) or PROFIBUS DP-V0 (optional).

4.3 Modbus-RTU (integrated in the VISIC50SF standard version)

The Modbus-RTU interface allows the user to read out the VISIC50SF measured values and status information using the two function codes “Read Holding Register (0x03)” and “Read Coil (0x01)”.

+i The protocol (Modbus-RTU/ TAD control unit) can be set on the RS-485 interface using the device display. See Section “Menu”, see [“Setting the RS-485 interface with submenu item “Bus””, page 56.](#)

Modbus-RTU interface configuration options

The Modbus-RTU interface can only be configured using the device display. The following parameters can be changed here:

- Modbus-RTU ID (0 to 247), see Section “Menu”, see [“Setting bus parameters”, page 57](#)
- Data transfer format, see Section “Menu”, see [“Setting the Modbus data transfer format with menu item “MB Par””, page 58.](#)
- Baudrate, see Section “Menu”, see [“Setting the Modbus baud rate with menu item “MB BdR””, page 59.](#)

+i The VISIC50SF must be restarted to save parameter changes. Press “Reset” to restart, see [“Measuring unit - mainboard with display and keypad”, page 17](#)

4.3.1 Modbus-RTU data format

Parity	Even parity, 1 stop bit
	Odd parity, 1 stop bit
	No parity, 1 stop bit
	No parity, 2 stop bits

4.3.2 Modbus-RTU baud rates

- 4.8 k
- 9.6 k
- 19.2 k
- 38.4 k
- 57.6 k

4.3.3 Read Holding Register

The Modbus-RTU interface register structure comprises all measured values and associated measured value status. The coding of the measured value status behaves synchronous to the measured value status of the PROFIBUS interface, see [“Connection unit voltage supply”, page 34](#).

Table 9: Read Holding Register Modbus-RTU

Register	Designation	Significance
100	K-value, 4 byte floating point, ABCD	Visibility value
102	K-value status, 1 byte unsigned integer	Status of visibility value
103	Gradient K-value, 4 byte floating point, ABCD	Gradient of the K-value
105	K-value status, 1 byte unsigned integer	Status of visibility value
106	Uptime [h], 2 byte unsigned integer	Uptime: Operating hours since last reset
107	OpTimes [d], 2 byte unsigned integer ABCD	OpTimes: Total operating time in days
108 ... 117	Reserved	
118	Contamination, 2 byte unsigned integer	Contamination: Contamination of sensor in percent
119	Temperature PT1000t, 4 byte floating point, ABCD	Measured value, external PT1000, optional
121	Temperature status, 1 byte unsigned integer	Gradient of external temperature value. PT1000, optional
122	Temp. grad. PT1000t, 4 byte floating point, ABCD	
124	Temperature status, 1 byte unsigned integer	

Register 118 contains information on the actual degree of contamination of the optics.

Coding of registers 125 & 126 (Maintenance Request/ Device Fault), see [“Device error coding”, page 95](#) and see [“Description of maintenance requests”, page 96](#).

Example:

Read 4 Byte Float from Server (ID 101) with start address 100:

TX-> <65 03 00 64 00 02 8D F0>

RX-> <65 03 04 3F 48 2B 67 0C ED>

Current K-value = 0x41B80000 = 23

4.3.4 Modbus-RTU Read Coil (0x01)

Function code “Read Coil (0x01)” serves to read out all malfunction and maintenance request messages from VISIC50SF.

Table 10: Read Coil Modbus-RTU

Coil number	Designation
200	Contaminated optics
201-215	Reserved
216	Error Vis
217 + 218	Reserved
219	Error EEPROM
220	Error heating
221	Error 4 ... 20 mA interface
222	Error FPGA
223	Error CPU
224	Error in code execution
225	Error enclosure cover
226 ... 229	Reserved
230	Maintenance active
231	Reserved
232	VIS limit active
233	Gradient VIS limit active
234	Temperature limit active
235	Gradient temperature limit active
236 ... 237	Reserved

Example:

Read Coil Number 200 from server (ID 101):

TX-> <65 01 00 C8 00 01 74 10>

RX-> <65 01 01 00 4E B8>

Maintenance request Vis = false

4.4 PROFIBUS DP-V0 (optional)

The PROFIBUS module belongs to the VISIC50SF when configured at the same time during ordering. The VISIC50SF is integrated in the bus via a restart after wiring.

4.4.1 PROFIBUS addressing

The PROFIBUS-DP address of the device can be set via the keypad.

For further information, see Section “Menu”, see [“Setting the PROFIBUS address in “PB ID””, page 57](#).



The device must be restarted after the address is changed. Press “Reset” to restart, see [“Measuring unit - mainboard with display and keypad”, page 17](#)



The PROFIBUS address can also be assigned by the master. But it is not saved fail-safe in the device.

4.4.2 PROFIBUS DP-V0 baud rates

The PROFIBUS module has an autobaud function that automatically detects the following baud rates:

- 9.6 k
- 19.2 k
- 45.45 k
- 93.75 k
- 187.5 k
- 500 k
- 1.5 M

4.4.3 Access via GSD file for configuration 1



Configuration 1:

- Values can only be read.
- GSD file V1.2 required

The GSD file provided allows access to the following modules on the PROFIBUS master:

Table 11: GSD file modules

Module (coding)	Significance
kValue (real) Status (UInt8)	Visibility measured value + status
Temperature (real) Status (UInt8)	Temperature of optional PT1000 sensor + status
Contamination (UInt16)	Contamination of sensor in percent
UpTime [h] (UInt16)	Operating duration of the sensor since last reset in hours
OpTime [d] (UInt16)	Operating duration of the sensor in days
MainReq (UInt16)	Maintenance request, coded bit-by-bit, see “Description of maintenance requests”, page 96
DeviceFault (UInt16)	Error status byte, see “Device error coding”, page 95
LimitState(UInt16)	Active limit values, coded bit-by-bit
	Bit0 = Limit VIS
	Bit1 = Limit gradient VIS
	Bit2 = Limit temperature
Counter (UInt16)	Measured value meter
CRC16-CCITT (UInt16)	Checksum according to CRC16-CCITT



The GSD file is delivered on a data medium when the PROFIBUS module is ordered.

4.4.4 Access via GSD file for configuration 2



Configuration 2:

- Values can be changed via Profibus.
- GSD file V1.3

The GSD file provided allows access to the following modules on the PROFIBUS master:

Table 12: GSD file modules

Module (coding)	Significance
kValue (real) Status (UInt8)	Visibility measured value + status
Temperature (real) Status (UInt8)	Temperature of optional PT1000 sensor + status
Contamination (UInt16)	Contamination of sensor in percent
UpTime [h] (UInt16)	Operating duration of the sensor since last reset in hours
OpTime [d] (UInt16)	Operating duration of the sensor in days
MainReq (UInt16)	Maintenance request, coded bit-by-bit, see “Description of maintenance requests”, page 96
DeviceFault (UInt16)	Error status byte, see “Device error coding”, page 95
LimitState(UInt16)	Active limit values, coded bit-by-bit
	Bit0 = Limit VIS
	Bit1 = Limit Gradient VIS
	Bit2 = Limit Temperature
	Bit3 = Limit GradientTemperature
	Bit4 = Limit Contamination
	Bit5 = Pre-alarm VIS
	Bit6 = Pre-alarm Gradient
	Bit7 = Pre-alarm Temperature
	Bit8 = Pre-alarm Gradient Temperature
Bit9 = Pre-alarm Contamination	
Store Limit (UInt16)	0xA1: Saves limit values changed via Profibus into EEPROM
Use BusLimit (UInt16)	0x5555: Selection of the limit values to be used: <ul style="list-style-type: none"> • Limit values that are transferred via the bus or • saved limit values
Counter (UInt16)	Measured value meter
CRC16-CCITT (UInt16)	Checksum according to CRC16-CCITT



The GSD file is delivered on a data medium when the PROFIBUS module is ordered.

Setting and accepting limit values

The following limit values can be set via the Profibus:

- K-value limit value 1 Pre-alarm
- K-value limit value 2 Alarm
- Contamination limit value 1 Pre-alarm
- Contamination limit value 1 Alarm

The limit values set via the bus are only transferred to the EEPROM of the VISIC50SF on request. The module "Store Limit (UInt16), 0xA1" is used here:

- Bit 0 = K-value limit value 1 Pre-alarm
- Bit 1 = K-value limit value 2 Alarm
- Bit 2 = Contamination limit value 1 Pre-alarm
- Bit 3 = Contamination limit value 1 Alarm
- Bit (15 .. 4) must be transferred as = 010101010101 xxxx.



NOTICE:

The trigger signal to store the limit values in the EEPROM of the VISIC50SF must be active for **at least 2 seconds**. This is necessary to safely recognize and adopt the value.

Selecting limit values

The bus can be used to select which limit values are to be used. Options to choose from:

- Limit values that are transferred via the bus
- Limit values stored in the device

The module "Use BusLimit (UInt16), 0x55" is used for this purpose. If bit pattern 0x5555 is set, the limit values sent via the bus are used. Otherwise, the limit values stored in the sensor are used.



The display in the VISIC50SF always shows the **active** limit value.



The DO relays behave as configured under the DOMode function, see "Setting digital outputs with "DOMode" (optional)", page 67

4.4.5 Measured value coding

Every VISIC50SF measured value has a measured value status. The following Tables show the measured value status coding and significance.

Table 13: Measured value status of visibility

Priority	Status of visibility	Status byte PROFIBUS/Modbus	Status byte designation	Maintenance request	Device fault	4 ... 20 mA
1	No error active	0x80	Good - OK	Inactive	Inactive	Value
2	Measured value dynamic below limit value	0xA4	Good - OK	Active	Inactive	Value
3	Contamination 1 st level	0xA4	Good - maintenance required	Active	Inactive	Value
4	Measuring range overflow	0x7A	Uncertain - high limit	Inactive	Inactive	23 mA 20 mA ^[1]
5	Contamination 2 nd level	0x68	Uncertain - maintenance demanded	Active	Active	1 mA
6	Error µC	0x24	Bad - maintenance alarm	Inactive	Active	1 mA
7	Threshold LED	0x24	Bad - maintenance alarm	Inactive	Active	1 mA
8	Error FPGA	0x24	Bad - maintenance alarm	Inactive	Active	1 mA

[1]When the TAD control unit is used with I/O modules

Table 14: Measured value status of temperature sensor

Priority	Status of temperature measurement	Status byte PROFIBUS/Modbus	Status byte designation	Maintenance request	Device fault	4 ... 20 mA
1	No error active	0x80	Good - OK	Inactive	Inactive	Value
2	PT1000 sensor not connected	0x23	Bad - passivated	Inactive	Inactive	1 mA
3	PT1000 sensor error	0x24	Bad - maintenance alarm	Inactive	Inactive	1 mA
4	Error µC	0x24	Bad - maintenance alarm	Active	Inactive	1 mA

4.5 RS-485 - topology and bus termination

When using the RS-485 interface, all field devices are typically connected to one bus structure (line) (see “Bus topology”, page 47). Each segment can have up to 32 nodes (master and slaves). The start and end of each segment must be terminated with a bus termination. A switch on the main board serves to set the bus termination on a VISIC50SF see “Bus termination on the main board”, page 47.

Fig. 33: Bus topology

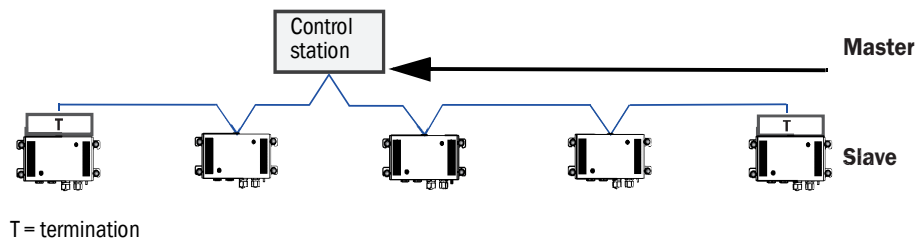
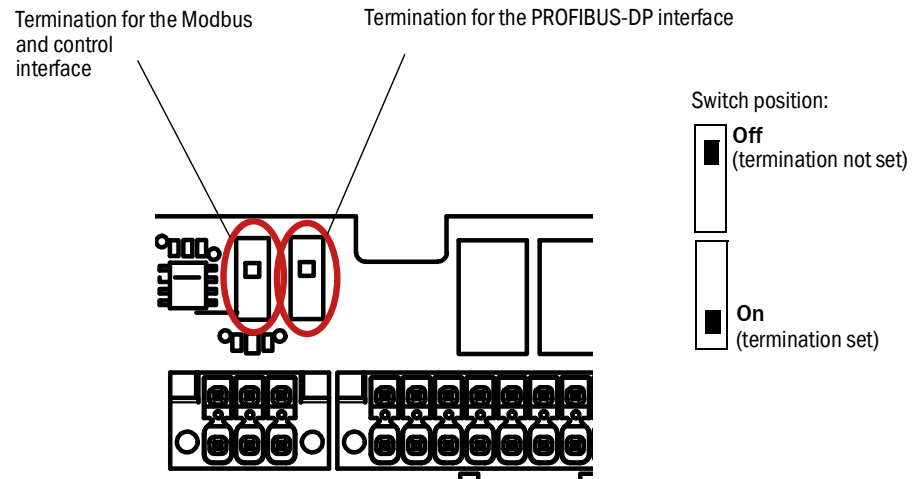

Fig. 34: Bus termination on the main board



4.6 Stub line lengths for connection unit on all RS-485 bus systems

According to the PROFIBUS specification, a maximum total of all stub lines of 6.60 m is allowed per DP segment for a bit rate of 1.5 Mbits/s. Longer stub lines are allowed for lower data rates.

Table 15: Maximum stub line lengths

Bit rate	Total capacitance allowed	Sum of stub line lengths
1.5M bit/s	0.2 nF	6.6 m
500 kbit/s	0.6 nF	20 m
187.5 kbit/s	1.0 nF	33 m
93.75 kbit/s	3.0 nF	100 m
19.2 kbit/s	15 nF	500 m

If there are more than 32 nodes or the network span is being extended, power amplifiers (repeaters) allow linking the networks.

Cable properties for using the RS-485 interface

Endress+Hauser recommends using type A shielded cables:

Table 16: Cable properties for the RS-485 interface

Surge impedance R_w	135...165	Ohm
Capacitance per unit length C'	< 30	pF/m
Loop resistance R'	110	Ohm/km
Wire diameter d	0,64	mm
Wire cross-section q	> 0.34	mm ²



Shielded cable type A is a twisted two-wire cable.

5 Operation

5.1 Operating and display elements

5.1.1 Display with keypad in VISIC50SF

Fig. 35: Display and keypad in VISIC50SF

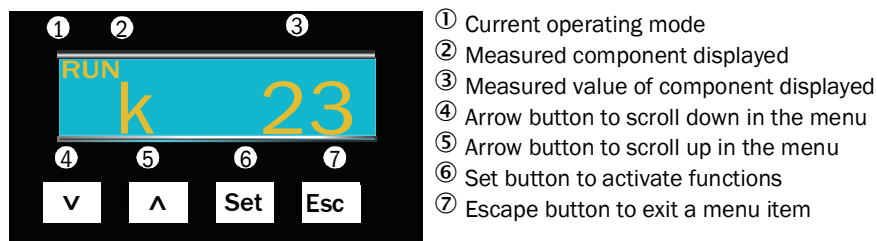

The display lighting goes on when a button is pressed. The lighting goes off 10 minutes after the last button was pressed.

Menu items

- Measuring screen
 - Visibility
 - Contamination
 - Temperature (optional)
- Status information
- Software version
- Operating time display
- Device address assignment
- Inputs/outputs test
- Scaling of analog output for visibility
- Setting the limit values



More information on menu navigation can be found in Section “Menu”, see [“Menu navigation VISIC50SF”, page 52.](#)

5.1.2 Reset button and “Maint” LED

The Reset button restarts the VISIC50SF.

Fig. 36: Position of the Reset button and “Maint” LED on the main board

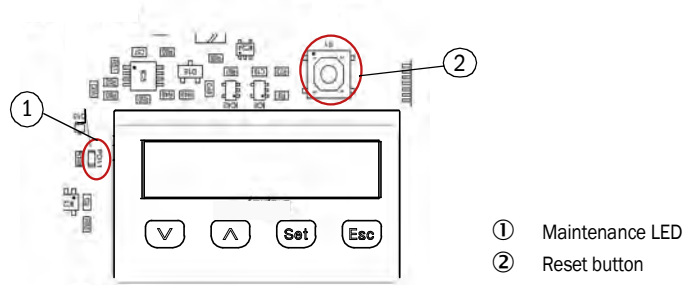

5.1.3 Display unit in the TAD control unit

see [“Operating and display elements \(with menu example\)”, page 70.](#)

5.2 Operating states

5.2.1 Checking the operating state (visual control)

Status LED

The Status LED on the underside of the enclosure shows the operating state, see [“VISIC50SF sensor”, page 12](#)

Table 17: LED display of operating states

Operating state	Relay state	Status LED color
Initialization	Maintenance request relay open Malfunction relay open Relay limit value open	Red
Operation	Maintenance request relay open Malfunction relay closed Relay limit value open	Green
Maintenance request	Maintenance request closed Malfunction relay closed Relay limit value open	Yellow
Fault	Maintenance request open/closed depending on maintenance request state Malfunction relay open Relay limit value open	Red
Limit value exceeded (limit)	Maintenance request relay open Malfunction relay closed Limit value relay closed	Green
Limit value exceeded (PreLim) ^[1]	Pre-alarm relay closed Malfunction relay closed Main alarm rrelay open	Green

[1] Only when optional assignment of digital outputs is selected, see [“Setting digital outputs with “DMode” \(optional\)”, page 67](#).

The device delivers a valid measured value in operating states operation and maintenance request.

5.2.2 Checking malfunction displays

Read out the error code (see [“Calling up maintenance request and malfunction messages with menu item “Status””, page 54](#)).

5.3 Checking the analog outputs

Check the analog output for the K-value, see [“Testing the analog output for the K-value with menu item “k””, page 60](#).

Check analog outputs for the temperature value, see [“Signal test “IO test””, page 60](#).

5.3.1 Reading off measured values

Measured values can be displayed on the single-line, illuminated display. see [“Display and keypad in VISIC50SF”, page 49](#). Further information on menu navigation to display measured values can be found in Section “Menu”, see [“Measuring operation mode “RUN””, page 52](#).

5.4 Operating functions

[see “Menu navigation VISIC50SF”, page 52.](#)

5.5 Status messages

[see “Checking the operating state \(visual control\)”, page 50.](#)

5.5.1 Malfunction messages

[see “Device error coding”, page 95.](#)

5.5.2 Maintenance request messages,

[see “Description of maintenance requests”, page 96.](#)

6 Menu navigation VISIC50SF

6.1 Menu structure

The menu is split into 2 modes:

- 1 "RUN" = operation mode
- 2 "SET" = setting mode

6.1.1 Short description: Settings using the keypad

- ▶ Use the arrow buttons to scroll through the menu.
- ▶ Button "Set" serves to switch to the menu structure.
- ▶ Button "Esc" aborts a process or switches up one menu level.
- ▶ Use the *Arrow buttons* buttons to enter numeric values:
Use the arrow buttons to scroll through the digits and press the button to increase or decrease these by 1. Use "Set" to switch between the digits shown on the display.

6.1.2 Input field with a blinking digit to be edited



6.2 Measuring operation mode "RUN"

Inquire the current measured values in active measuring operation.

Fig. 37: "RUN" mode overview

RUN **k** **XXX**

k = visibility
XXX = placeholder for measured value



RUN **con** **XX%**

con = contamination/soiling
XXX = placeholder for measured value

- Value ≥ 10: conXX%
- Value < 10: conX%



RUN **T** **XXX**

T = temperature
XXX = placeholder for measured value

- Value ≥ 10: T XX
- Value < 10: T X
- Value < 0: T -X
- Value ≤ 10: T -XX

6.3 “SET” mode

“SET”- mode is a setting mode to modify VISIC50SF settings.
werden können.



NOTICE: The VISIC50SF may be operated by competent persons only who, based on their device-specific training and knowledge of the device as well as knowledge of the relevant regulations, can assess the tasks given and recognize the hazards involved.

6.3.1 Navigation in “SET” mode

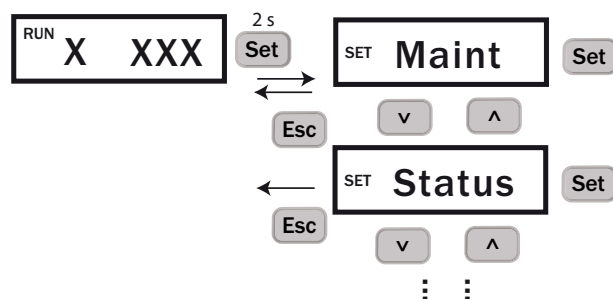

- 1 Switch from “Run” to setting mode “Set”: In operating mode “RUN”, press the “Set” button in any measuring component displayed for 2 seconds.
- 2 “SET” mode is now active with menu item “Maint”.
- 3 Use the arrow keys to scroll through the menu until the desired menu item is reached.
- 4 Press “Set” to access the submenu items.
- 5 Use the arrow keys to scroll through the submenu items.
- 6 Press “Set” to activate or change a submenu item.
- 7 Use “Esc” to exit the submenu or main menu items.



The device switches automatically to “RUN” mode when no user action is registered for 10 minutes. The background lighting goes off.

6.3.2 Structure and sequence of submenu items

- | | | |
|----|----------|--|
| 1 | “Maint” | Activate maintenance |
| 2 | “Status” | Current device status |
| 3 | “Uptime” | Operating times display |
| 4 | “SWVers” | Software version |
| 5 | “Bus” | Bus settings |
| 6 | “Test” | Check analog and digital outputs. |
| 7 | “AO-HI” | Upper limit of scaling analog output 1 |
| 8 | “Limit” | Limit value settings |
| 9 | “PreLim” | Pre-alarm limit value setting |
| 10 | “Tuning” | Adjustment menu |
| 11 | “DOMode” | Digital outputs - optional setting |
| 12 | “Heat” | Activation of optional heating |

6.3.3 Activating maintenance in menu item "Maint"

Maint must be set "active" to carry out an I/O test.

Fig. 38: Activating the setting range via menu item "Maint"



- +i** Mode "active" is reset to "inactive" after 30 minutes.
- +i** The malfunction relay is activated when mode "active" is set. The Status LED is red, the analog outputs output 1 mA and the field bus interface signals an error. The Maint LED on the main board lights up yellow. Further information on the position of the Maint LED on the main board can be found under, [see "Position of the Reset button and "Maint" LED on the main board", page 49.](#)

6.3.4 Calling up maintenance request and malfunction messages with menu item "Status"

When a maintenance request or malfunction message is present, the associated maintenance request or malfunction message is output as an error code in this menu item. Scroll through with the arrow keys to display all existing error or maintenance request messages.

- +i** Abbreviations in the menu:
MRq = Maintenance Request
Fail = malfunction
MrqXXX and F_XXX= code for maintenance request or malfunction. The Error Code Table can be found in Section "Maintenance", [see "Device error coding", page 95.](#)

Fig. 39: Retrieving maintenance and malfunction messages

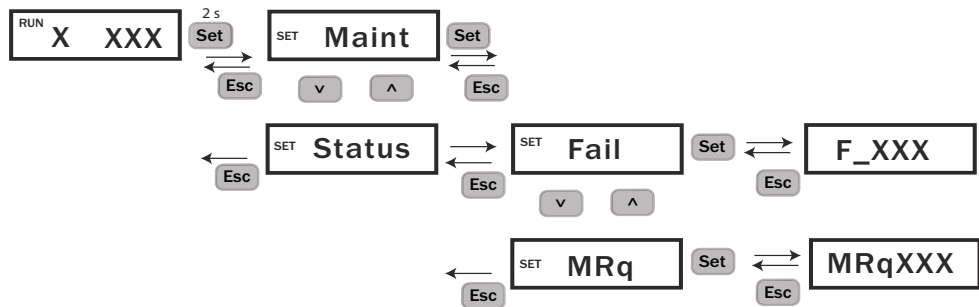

6.3.5 Calling-up the operating duration in submenu item “Uptime”

Menu item “Uptime” retrieves the following information:

- Up: Number of operating hours (h) since the last switch-on.
- Run: Operating duration since initial commissioning in days (d).

Fig. 40: Calling up the operating duration

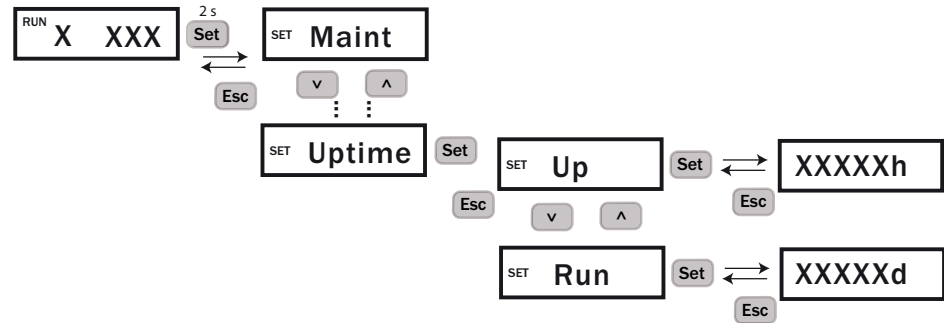

6.3.6 Calling up the software version in submenu item “SwVers”

The software version is shown as a 7-digit number and a 4-character change index.

Fig. 41: Calling up the software version

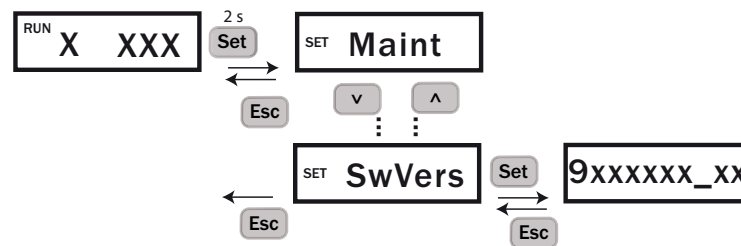

+i The software version is output as ticker text.

6.4 Connecting the bus systems

The VISIC50SF has an RS-485 output as standard. This can be used for a Modbus connection to a central control system or to connect to the TAD control unit with integrated I/Os. The keypad serves to configure the RS-485 interface assignment.

6.4.1 Setting the RS-485 interface with submenu item “Bus”

Assignment of RS-485 interface:

- TAD (TAD control unit)
- MB (Modbus)
- IO (external modules)
- TAD + IO (Tad control unit with integrated I/O modules)

A change of the RS-485 interface assignment is first effective after a restart.

Fig. 42: Selecting the RS-485 interface protocol

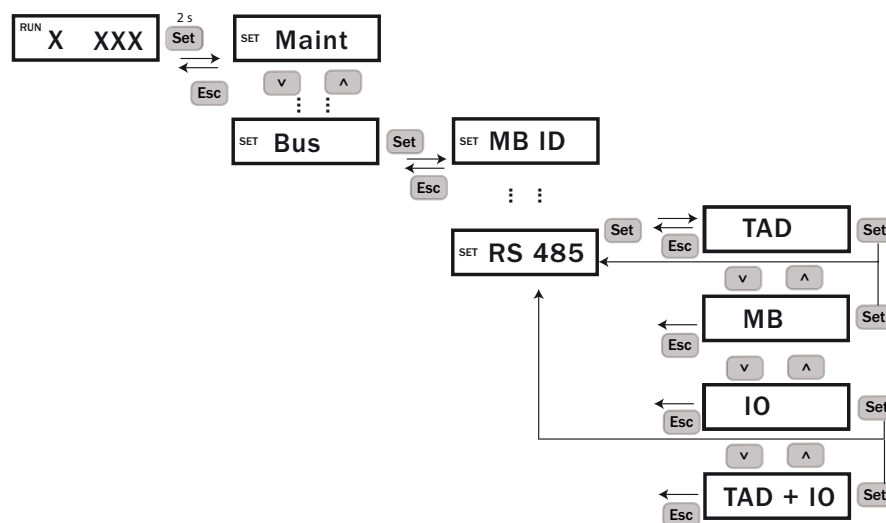

+i Only one assignment can be selected at a time.

+i A second RS-485 interface is firmly assigned to an optional PROFIBUS module, see [“PROFIBUS DP-V0 \(optional\)”, page 42](#)

6.5 Setting bus parameters

Menu item “Bus” serves to manage the parameters for the Modbus, PROFIBUS and control unit interfaces. A change to the bus system is first effective after a restart.

+i Press “Reset” to restart, see “Measuring unit - mainboard with display and keypad”, page 17

6.5.1 Setting the PROFIBUS address in “PB ID”

The configured address is assigned to the VISIC50SF after a restart when the device is connected as “slave” in a PROFIBUS-DP system. Submenu item “PB ID” serves to manage the PROFIBUS address. The valid address range is between 0 ... 125.

Arrow buttons: Incrementing and decrementing the digits.

“Set” button: Next digit is activated.

+i Submenu item “PB ID” is only available when the VISIC50SF has a PROFIBUS-DP module installed.

Fig. 43: Entering the PROFIBUS address

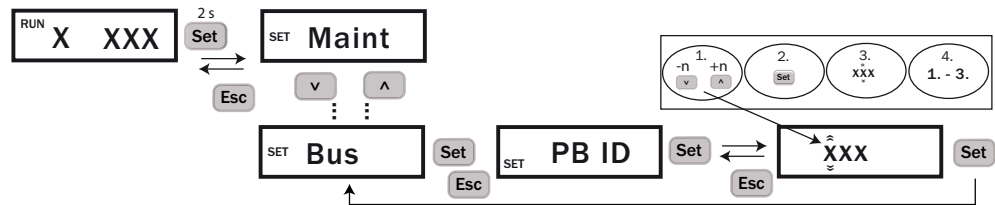

+i When the bus address has been entered completely, pressing “Set” switches the menu back directly to the “Bus” main menu.

6.5.2 Setting the PROFIBUS configuration under “PBCONF”

The device can be operated in two different Profibus configurations.

- Configuration 1: Values can only be read.
- Configuration 2: Values can be changed via Profibus.

+i Configuration 1 requires GSD file V1.2
Configuration 2 requires GSD file V1.3.

Fig. 44: Entering the PROFIBUS configuration

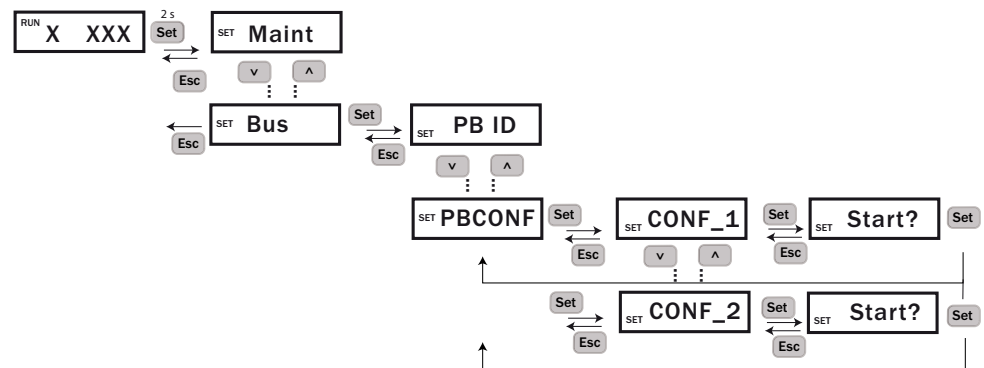

6.5.3 Setting the Modbus address in “MB ID”

The device address can be entered in menu item “Bus”, submenu item “MB ID” when the device is connected as “slave” in a Modbus system. The address range is between 0 ... 247.

Arrow buttons: Incrementing and decrementing the digits.

“Set” button: Next digit is activated. All digits must be confirmed. Call up the menu again to recheck the entry.

Fig. 45: Entering the device address

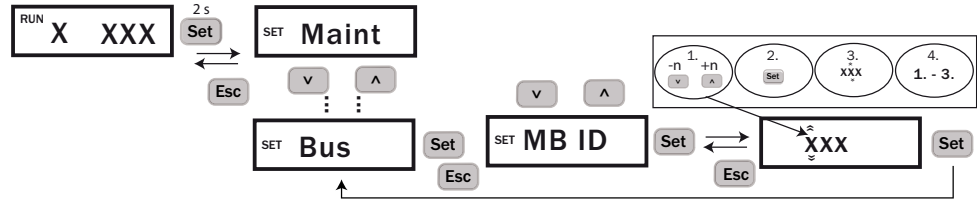

i When the bus address has been entered completely, pressing “Set” switches the menu back directly to the “Bus” main menu. The setting is saved when the VISIC50SF is restarted.
 Press “Reset” to restart, see “Measuring unit - mainboard with display and keypad”, page 17

6.5.4 Setting the Modbus data transfer format with menu item “MB Par”

Submenu item “MB Par” serves to set the Modbus protocol parity:

- 1 start bit, 8 data bits, 1 stop bit, even parity (Even)
- 1 start bit, 8 data bits, 1 stop bit, odd parity (Odd)
- 1 start bit, 8 data bits, 1 stop bit, no parity (No 1 SB)
- 1 start bit, 8 data bits, 2 stop bits, no parity (No 2 SB)

Fig. 46: Setting the Modbus protocol parity

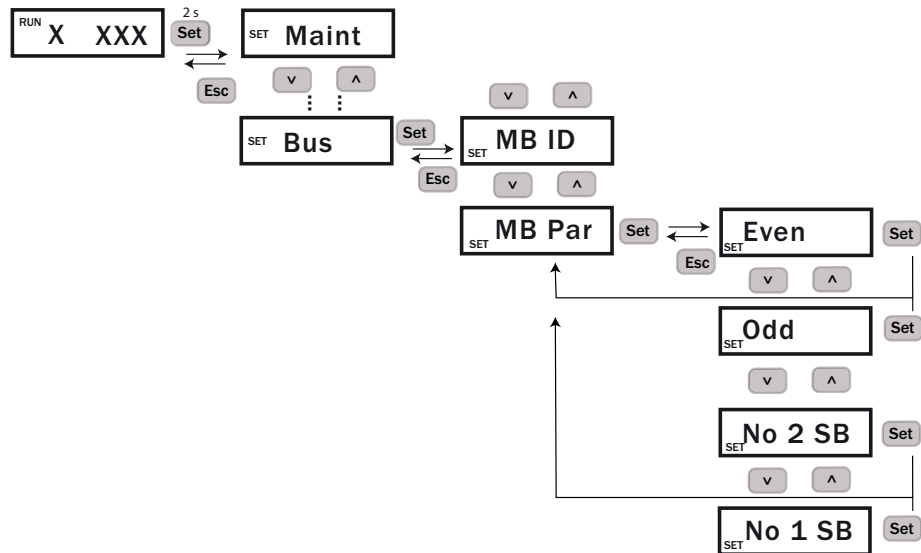

6.5.5 Setting the Modbus baud rate with menu item “MB BdR”

Submenu item “MB BdR” serves to set the Modbus interface baud rate:

- 4.8 k
- 9.6 k
- 19.2 k
- 38.4 k
- 57.6 k

The default setting is 19200 bit.

Fig. 47: Setting the Modbus interface baud rate

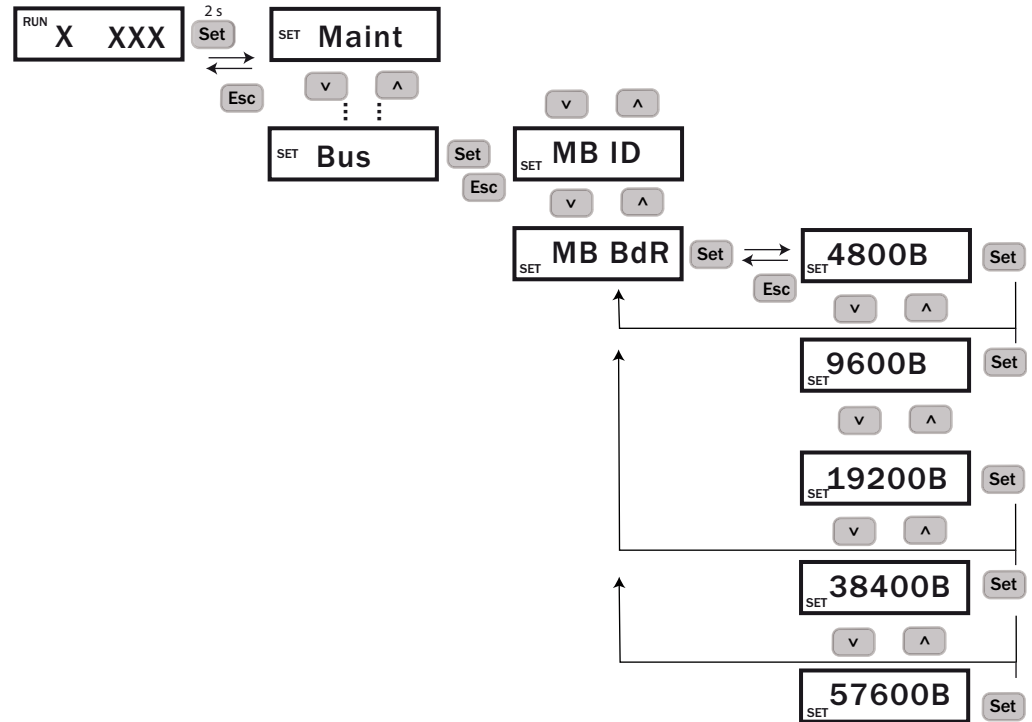

All “Bus” settings are first saved after a VISIC50SF restart.

6.6 Testing digital/analog outputs

The digital/analog outputs are tested under menu item “Test”.

+i Menu item “Test” is only available when menu item “Maint” has been set to active, see “Activating the setting range via menu item “Maint””, page 54.

6.6.1 Signal test “IO test”

The following signals can be set and/or tested:

- Analog output for K-value
- Analog output temperature (optional)
- Relay for maintenance request (“MRq)
- Relay for device malfunction (“Fail”)
- Relay for limit value signal

+i The selected current value is set only after the SET button has been pressed.

+i The mA value set on the analog output can be reset using “Maint” -> “inactive”. After 30 minutes, the VISIC50SF switches back automatically to measuring mode, see “Activating the setting range via menu item “Maint””, page 54.

6.6.2 Testing the analog output for the K-value with menu item “k”

Fig. 48: Setting and checking the milliampere setting of the analog output for the “k”-value

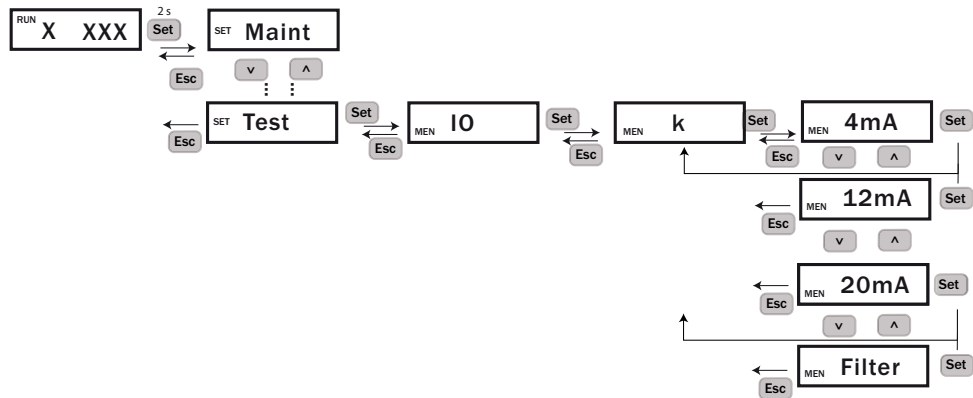

+i Submenu item “Filter” is required in connection with the test tool, description, see “Menu navigation with keypad to submenu item “Filter””, page 92.

6.6.3 Testing the analog output for the temperature value with menu item “Temp”

Fig. 49: Setting and checking the milliampere setting of the analog output for the temperature value

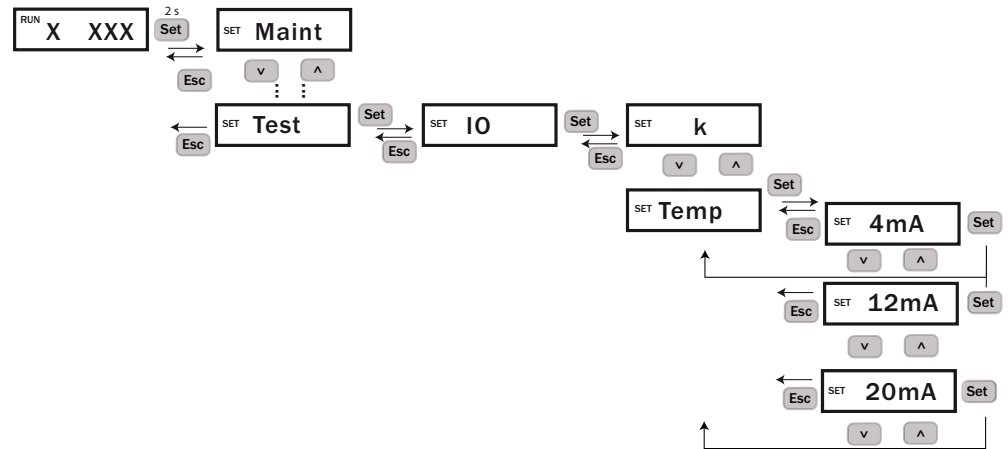

6.6.4 Testing the “Maintenance request” relay with menu item “MRq”

Maintenance mode must be activated.

Fig. 50: Setting and testing the maintenance request relay

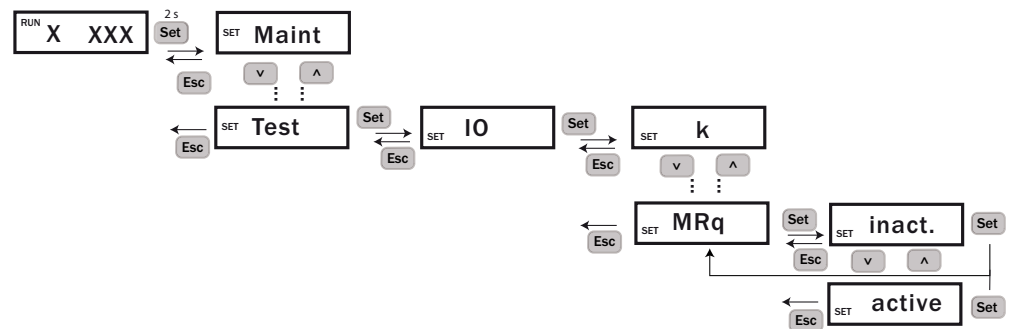

6.6.5 Testing the malfunction relay with menu item “Fail”

Maintenance mode must be activated.

Fig. 51: Setting and testing the device malfunction relay

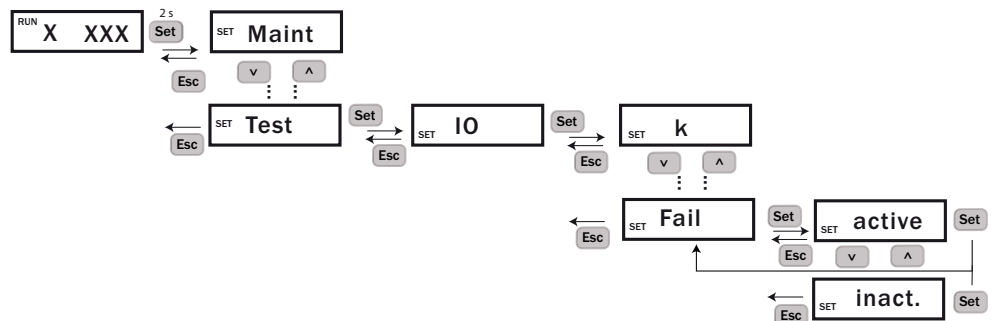

6.6.6 Testing the limit value relay with menu item “Limit”

Maintenance mode must be activated.

Fig. 52: Setting and checking the relay for the limit value

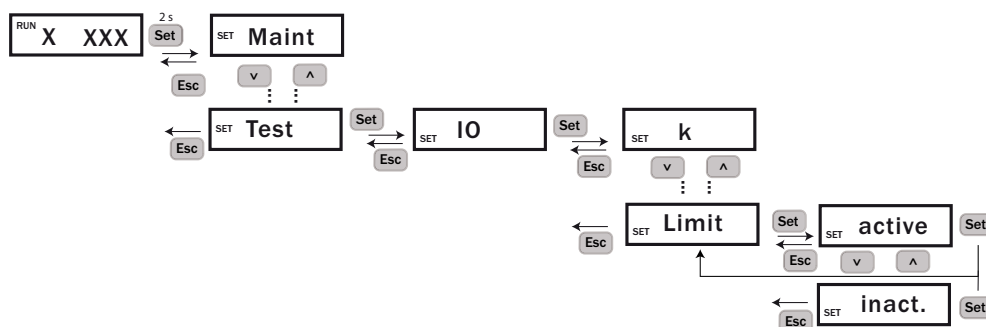

6.7 Upper limit for scaling of analog output with menu item “AO HI”

Function for setting the upper limit for scaling of analog output 1 (visibility). Maintenance mode must be activated.

Setting the upper value for the analog input scaling:

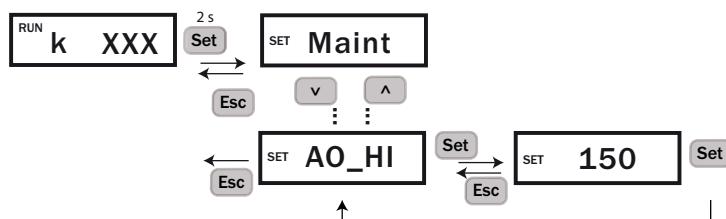

- ▶ Set a value between 150 and 15.
- ▶ Entry of a new value, see [“Short description: Settings using the keypad”, page 52.](#)

6.8 Setting limit values in the “Limit” menu item

The following limit values for the alarm output are set in the menu item:

- K-value (K)
- Gradient K-value (K_G)
- Temp (Temp)
- Gradient Temp (Temp_G)
- Contamination (Contam)

Arrow buttons: Incrementing and decrementing the digits.

- “Set” button: Next digit is activated. All digits must be confirmed. Call up the menu again to recheck the entry.

+i If an invalid value is entered the displayed value automatically jumps to the maximum allowed value.

6.8.1 Setting the limit value for the visibility value (K-value) using menu item “K”

Default setting: 015, min. value: 12 /km, max. value: 130 /km

Fig. 53: Setting the limit value for the visibility value (K-value)

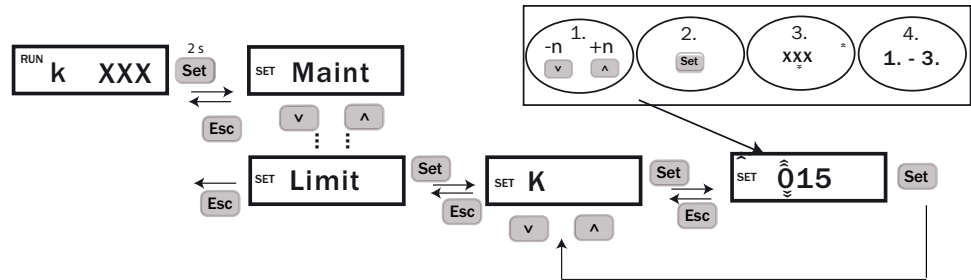

6.8.2 Setting the limit value for rate of increase of K-value with menu item “K_G”

Default setting: 000, min. value: 0 /km, max. value: 150 /km

Fig. 54: Setting the gradient value for the K-value

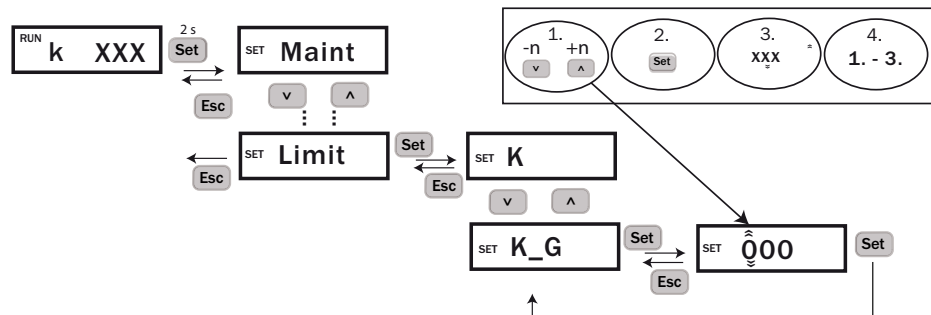

6.8.3 Setting the limit value for the temperature value with menu item “Temp”

Default setting: 00, Min. value: 0 °C, Max. value: 70 °C

Fig. 55: Setting the limit value for temperature

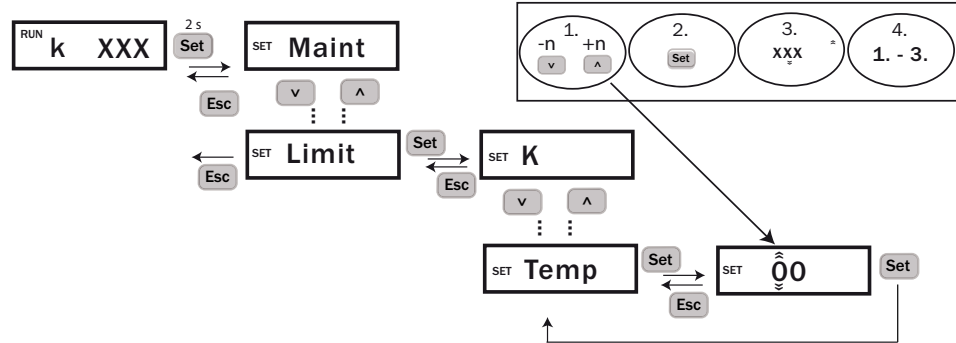

6.8.4 Setting the limit value for the gradient value of the temperature using menu item “Gradient Temp”

Default setting: 000, Min. value: 0 °C, Max. value: 105 °C

Fig. 56: Setting the gradient value for temperature increase

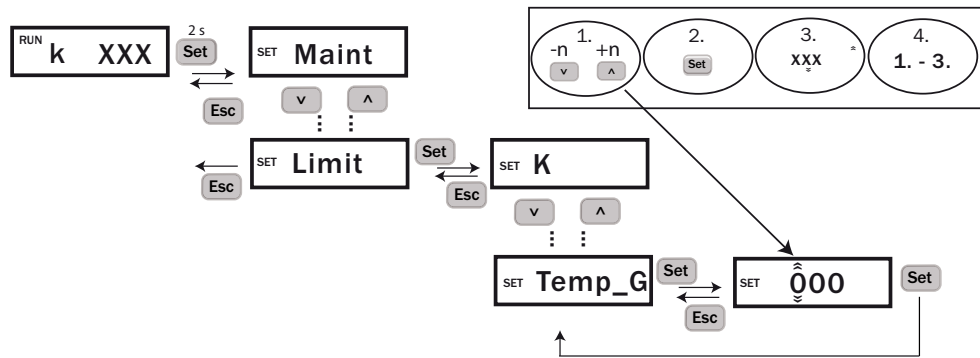

6.8.5 Setting the limit value for contamination with menu item “Contam”

Setting: Min. value: 5, Max. value: 99

Fig. 57: Setting contamination

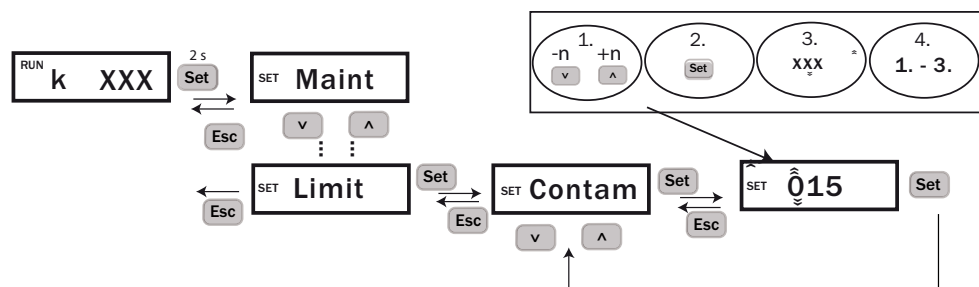

6.9 Setting limit values in menu item “PreLim” (optional)



NOTICE:

Use only with **optional assignment** digital outputs with malfunction, exceeding pre-alarm, exceeding main alarm.

To change from the standard assignment of the digital outputs to the optional assignment see “Setting digital outputs with “DMode” (optional)”, page 67

The following limit values for the alarm output are set in the menu item:

- K-value (K)
- Gradient K-value (K_G)
- Temp (Temp)
- Gradient Temp (Temp_G)
- Contamination (Contam)

Arrow buttons: Incrementing and decrementing the digits.

- “Set” button: Next digit is activated. All digits must be confirmed. Call up the menu again to recheck the entry.



If an invalid value is entered the displayed value automatically jumps to the maximum allowed value.

6.9.1 Setting the limit value for the visibility value (K-value) using menu item “K”

Setting: Min. value: 1 /km, max. value: 150 /km

Fig. 58: Setting the limit value for the visibility value (K-value)

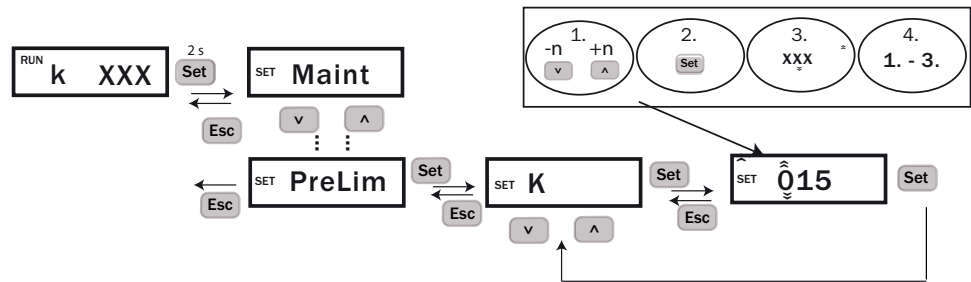

6.9.2 Setting the limit value for rate of increase of K-value with menu item “K_G”

Setting: Min. value: 0 /km, max. value: 150 /km

Fig. 59: Setting the pre-alarm gradient value for the K-value

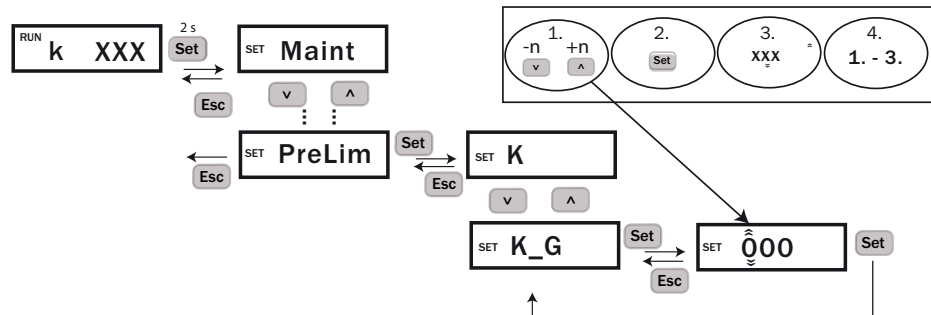

6.9.3 Setting the limit value for the temperature value with menu item “Temp”

Setting: Min. value: 0 °C, Max. value: 70 °C

Fig. 60: Set limit value pre-alarm for temperature

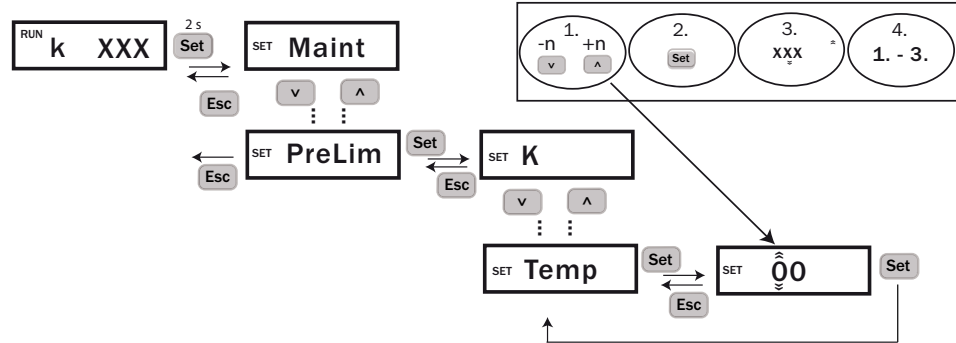

6.9.4 Setting the limit value for the gradient value of the temperature using menu item “Temp_G”

Setting: Min. value: 0 °C, Max. value: 100 °C

Fig. 61: Setting the pre-alarm gradient value for temperature increase

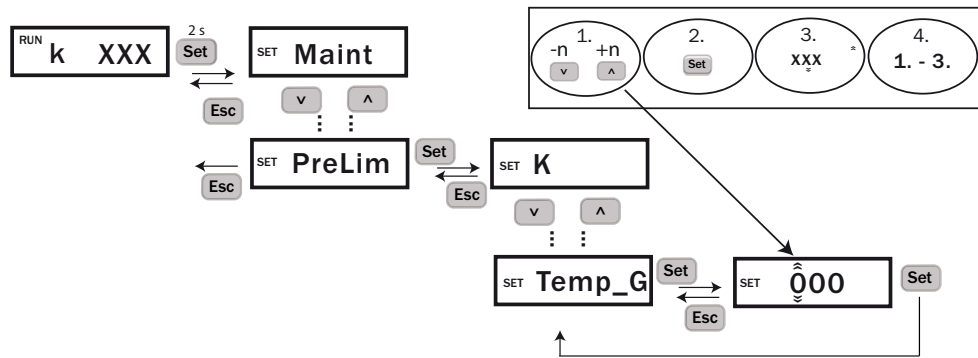

6.9.5 Setting the pre-alarm value for contamination with menu item “Contam”

Setting: Min. value: 5, Max. value: 99

Fig. 62: Setting the contamination pre-alarm

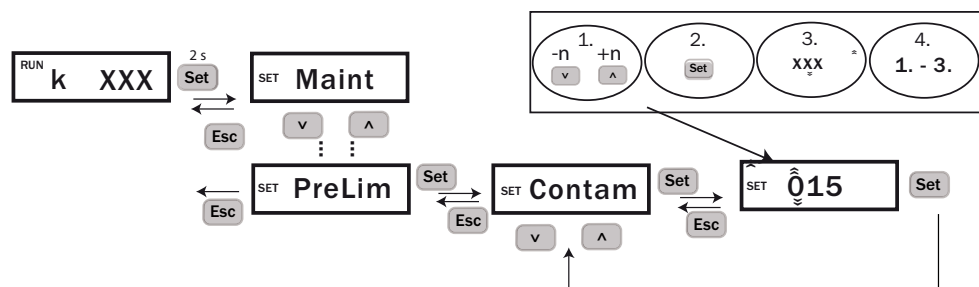

6.10 Device adjustment with submenu item "Tuning"

+i Menu item "Tuning" is only available when menu item "Maint" has been set to active, see "Activating the setting range via menu item "Maint"", page 54.

Function for executing device adjustment onsite. Description of the visibility test with VIS test tool, see "Visibility test with VIS test tool", page 89.

Fig. 63: Executing device adjustment

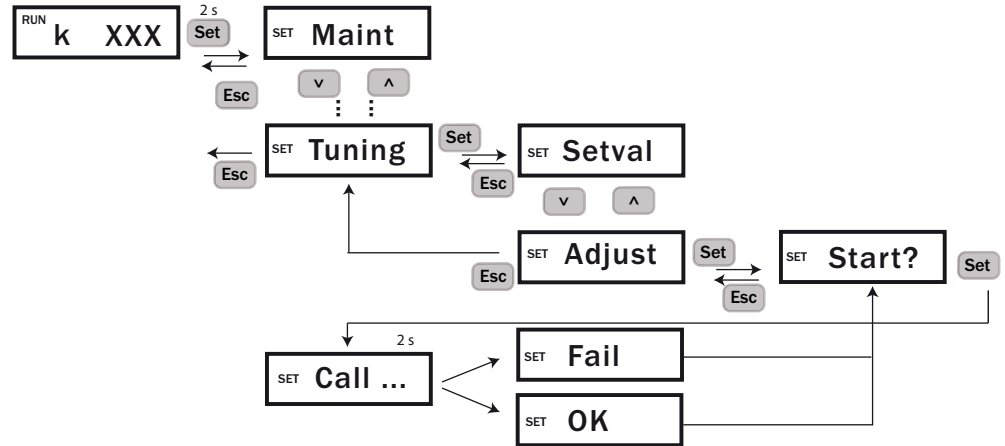

+i The test takes 2 seconds. Afterwards, it is displayed for 1 second whether the test was successful ("OK") or not ("Fail").

6.11 Setting digital outputs with "DOMode" (optional)



NOTICE:

Use only with optional assignment of the digital outputs with malfunction, exceeding pre-alarm, exceeding main alarm.

To set the limit values for the optional assignment, see "Setting limit values in menu item "PreLim" (optional)", page 65

Setting: Activate/deactivate Std or Limit mode

Fig. 64: Setting digital outputs

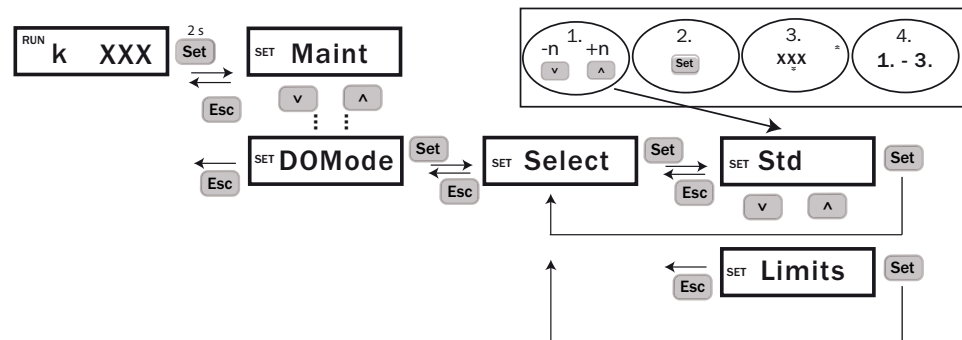

6.12 Activating/deactivating the heating (optional)

+i Menu item “Heat” is only available when menu item “Maint” has been set to active, see “Activating the setting range via menu item “Maint””, page 54.

The heating (optional) is activated or deactivated in the menu item “Heat”. The heating is only set to “active” at the factory when the device was ordered with heating.

Fig. 65: Activating/deactivating the heating (optional)

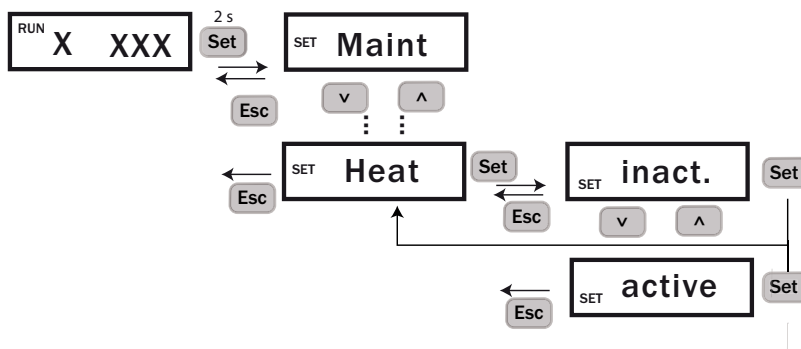

+i The heating is always activated when the measuring unit (2074558) is delivered as spare part.

7 Menu navigation TAD control unit

7.1 Basic features

Purpose

The display unit of the TAD control unit is a remote control unit for configuration and display of the VISIC50SF values.

Interface

- Sensor buttons
- Context-sensitive button functions, see [“Function buttons”, page 71](#).
- Display protected by glass plate

7.2 Main functions

Displays

- Measuring screens: Visibility, temperature
- 7 menu languages

7.3 Switch-on procedure

Switching on

- 1 Switch the VISIC50SF and control unit on (start main voltage supply).
 - » The “POWER“ LED of the control unit goes on.
 - » The Status LED on the VISIC50SF goes on.
- 2 Wait until the measuring screen appears, see [“Initialization phase”, page 72](#).
- 3 Check whether the VISIC50SF switches to measuring mode, see [“LED display of operating states”, page 50](#).

7.4 Operating elements

Fig. 66: Operating and display elements (with menu example)

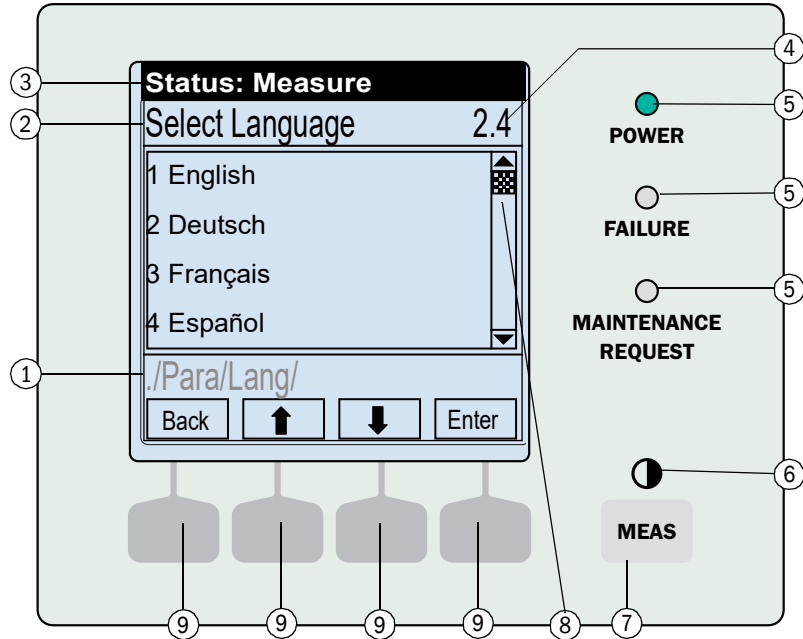



- ① Current menu branch
- ② Current menu
- ③ Status bar
- ④ Index
- ⑤ Status LED
- ⑥ Contrast icon, see "Setting the display contrast", page 75
- ⑦ "MEAS" button
- ⑧ Scroll bar
- ⑨ Function buttons, see "Function buttons", page 71

► To activate a function button: Simply touch the button surface with a finger.



The display lighting switches off automatically after 15 minutes.

7.4.1 LEDs

LED	Significance/possible causes
 POWER	The control unit is switched on, power voltage is available.
 FAILURE	<ul style="list-style-type: none"> • At least one error code is active. • The "Maintenance operation" state is activated manually.
 MAINTENANCE REQUEST	A MRq code is active on at least one sensor.

7.4.2 Function buttons

The current function of the function buttons is shown on the display (example, see [“Operating and display elements \(with menu example\)”](#), page 70).

Display	Function
“Back”	Return to the previous menu (inputs not saved are lost)
“Diag”	Call up current device status
“Enter”	Call up/start selected menu function
“Menu”	Call up the Main menu
“Save”	Save input/exit
“Set”	Start setting
“Select”	Select function/character
“Start”	Start procedure
“Login”	Password required
↑	<i>In a selection list:</i> Move cursor upwards
	<i>During input:</i> Next character
↓	Move cursor downwards
←	Move cursor to the left
→	Move cursor to the right

Table 18: Possible function button functions

7.5 Starting operation

7.5.1 Initialization phase

After the power supply is switched on, the display unit performs the initialization phase.

Fig. 67: Display contents during the initialization phase

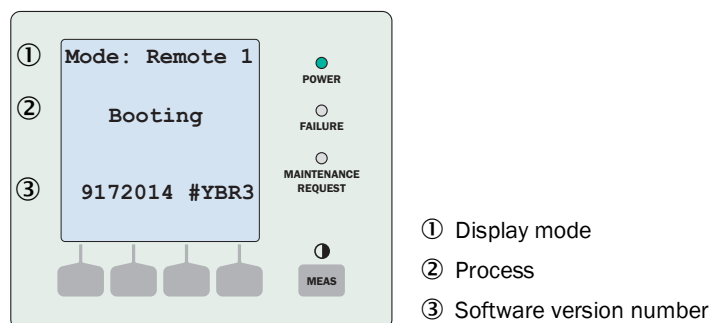

Changing the display mode

“Wait for communication” is shown on the display at the end of the initialization phase. The display mode is preset and must be Remote 1. Otherwise it must be changed accordingly.

- ▶ Press the “Mode” button for three seconds to change the settings.

Fig. 68: “Wait for communication” display text

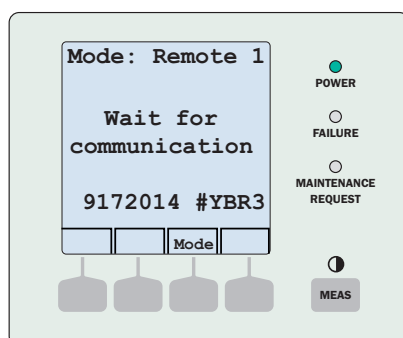

7.5.2 Measuring screens: List and bar display

List display

Fig. 69: Measuring screen as a list

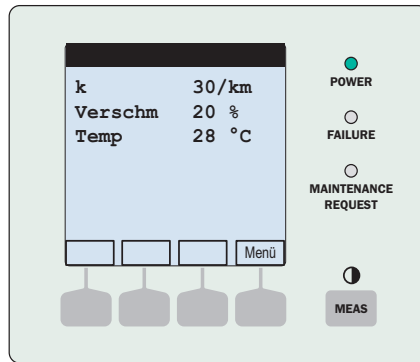

+i The temperature is displayed when a sensor is installed and delivers a plausible measured value in the range > -30 ... +70 °C, otherwise “-” is output.

Bar diagram

Fig. 70: Measuring screen as a bar diagram

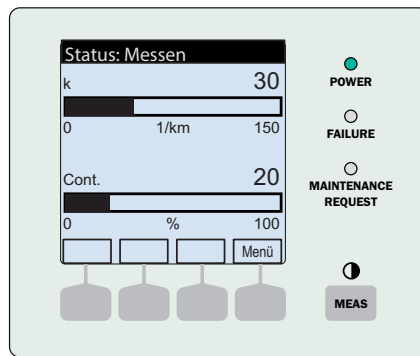

Table 19: Control options on the control unit display

Control	Action
Selecting a different measuring screen:	▶ Touch “MEAS” until the desired measuring screen is displayed.
Switching the measuring component:	▶ Touch ↓/↑.
Switching to the menu:	▶ Select “Menu”.
When a measured value blinks or an error or a maintenance request exists.	▶ Select “Diag”.

+i The list display is automatically displayed after switching on.

7.5.3 Displaying the Main menu

- ▶ When the measuring screen is active, see [“Measuring screens: List and bar display”](#), page 73: Select “Menu”.
- ▶ Select the *Back* button to return from the menu to the measuring screen.

Fig. 71: Main menu

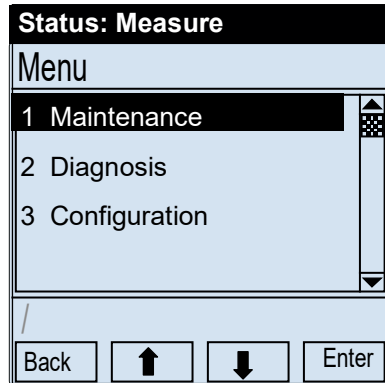

7.5.4 Selecting the menu item

- 1 Select desired function: Select ↓ / ↑.
- 2 Select “Enter”, “Set” or “Save” (depending on the display).

7.5.5 Returning to the measuring screen

- ▶ Press the “MEAS” button. This is possible from any menu item.

7.5.6 Selecting the menu language

Menu: Configuration/Select Language

Fig. 72: Menu “Select Language” (example)

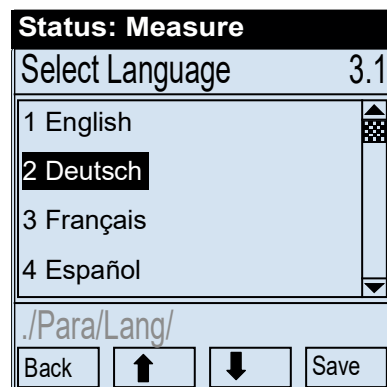

- ▶ Select the desired language (↓/↑, “Save”).



- Languages available: English, German, French, Spanish, Russian, Italian, Portuguese (Brazilian).
- The password must be entered to set the language. Entry of password, see [“Changing numerical parameters”](#), page 75.

7.5.7 Setting the display contrast

- 1 Press the “MEAS” button for 3 seconds.
 - » The measuring screen appears first.
 - » Then the menu to set the contrast appears.

Fig. 73: Menu to set the contrast

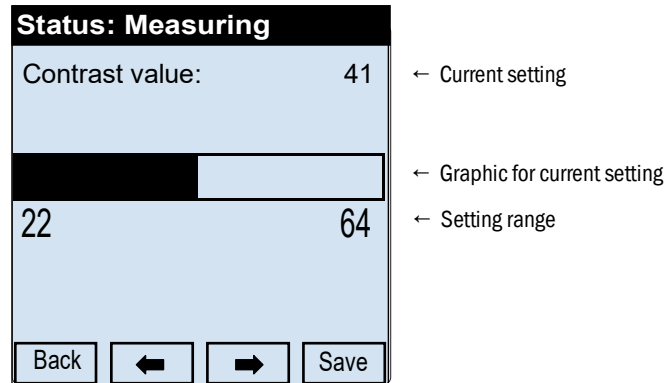

- 2 Select \leftarrow/\rightarrow until the desired setting is reached.
- 3 Save the values with “Save”.

7.5.8 Changing numerical parameters

Fig. 74: Changing numerical parameters (example)

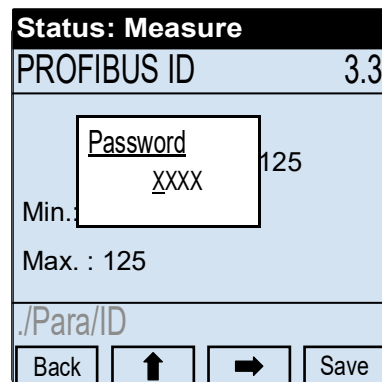

- 1 To move the cursor: Select \Rightarrow .
- 2 To change the selected digit: Select \uparrow until the desired digit is shown.
- 3 To set the displayed value: Select “Save”.
- 4 To abort the process: Select “Back”.



The password 1234 is predefined at the factory.

7.6 Activating Maintenance mode

The VISIC50SF is set to maintenance mode in the “Maintenance” menu item. This is required for:

- Maintenance work
- Function check with the VIS filter

Fig. 75: Switching the maintenance signal on/off

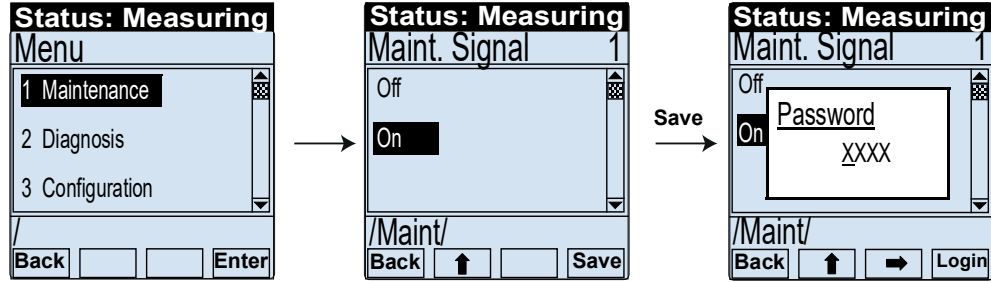

+i Password input, see “Changing numerical parameters”, page 75
 The four-digit password “1234” is predefined at the factory.

After the maintenance signal was activated, “Status Maintenance” is shown in the status bar. This status remains active for 30 minutes. All menu items remain accessible and executable.

Maintenance mode is terminated by setting the maintenance signal to “Off” or restarting the device.

7.7 Main menu item “Diagnosis”

The following data can be retrieved under main menu item “Diagnosis”:

- Uptime: Operating duration information
- Device Info
- Peripheral
- Messages: Current error and maintenance request messages
- I/O Test: Test of analog and status outputs

Fig. 76: Main menu item “Diagnosis”

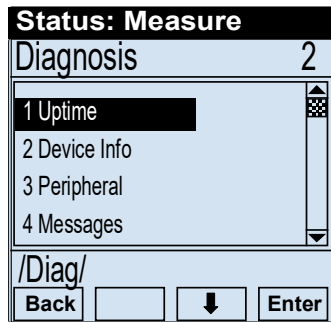

+i Current device errors can only be displayed via the “Diag” button or “Diagnosis/ Messages”.

7.7.1 Calling up the operation duration: “Uptime”

Menu item “Uptime” retrieves the following information:

- Uptime: Number of operating hours (h) since the last switch-on.
- VISIC50: Operating duration since initial commissioning in days (d).

Fig. 77: Calling up the operating duration

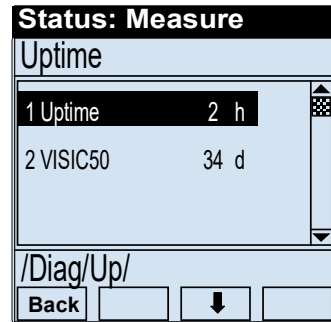

7.7.2 Retrieving device information with “Device Info”

The following device information can be retrieved under this menu item:

- Ser-No: The serial number is shown with an 8-digit number.
- SW-Ver.: The software version is shown with a 7-digit product number.
- SW-Rev: The revision index of the software version is shown with 4 characters. It can be numerical and/or alphanumerical.

Fig. 78: Retrieving the device information

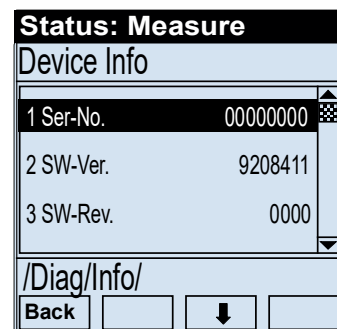

7.7.3 Retrieving the state of peripheral equipment with submenu item “Peripheral”

This menu item allows to check whether the following peripheral equipment has been activated:

- Heating
- DO module
- AO module

Fig. 79: Retrieving the status information of the peripherals

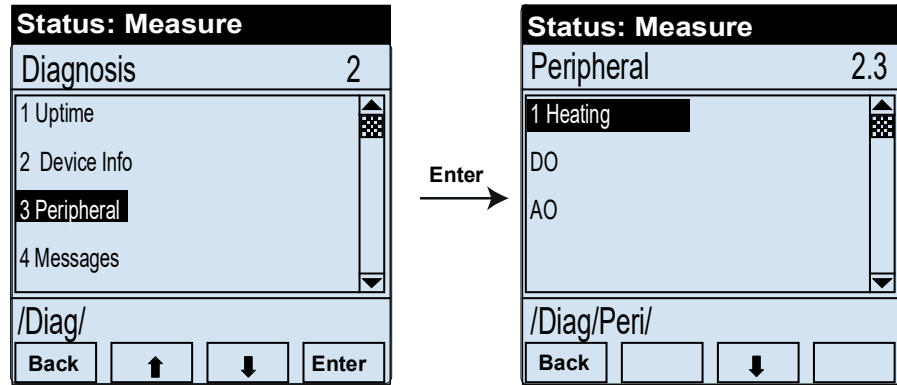

+i The status of the peripheral equipment cannot be changed in this menu item.

7.7.4 Displaying messages with menu item “Messages”

Three message groups exist:

- Fault
- Maintenance request
- Limit (limit values)

7.7.4.1 Error messages in submenu item “Fault”

Fig. 80: Retrieving malfunction messages in plain text (example)

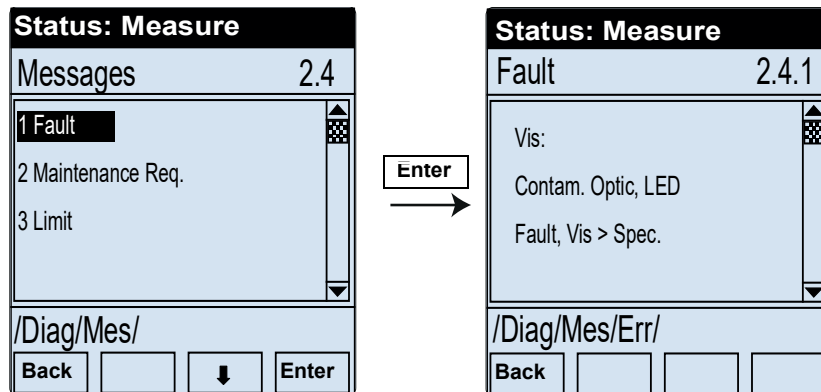

Error code Table, see “Device error coding”, page 95.

7.7.4.2 Maintenance requests in submenu item “Maintenance Req.”

Fig. 81: Retrieving maintenance requests in plain text (example)

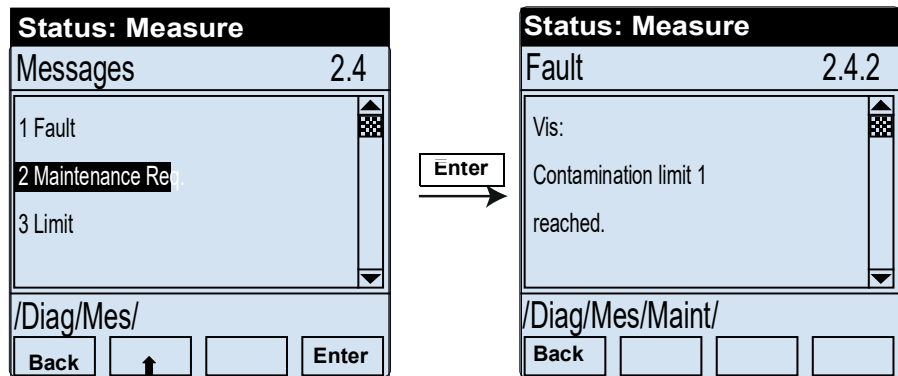
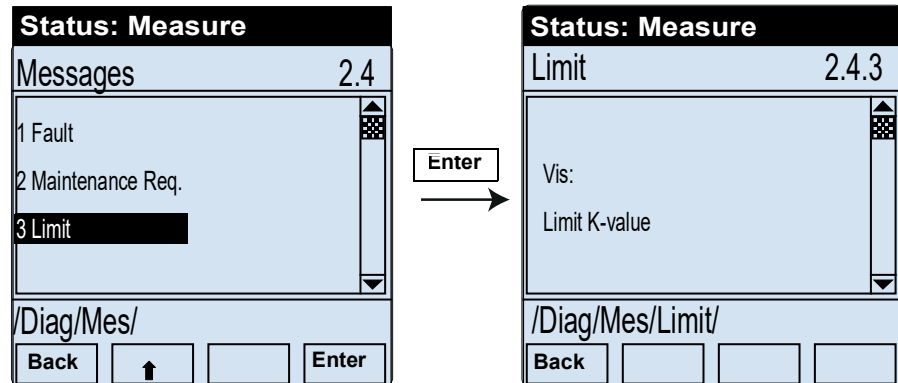

Table for explanation of specified codes under Maintenance request, see “Description of maintenance requests”, page 96.

7.7.4.3 Active limit value messages in the submenu item “Limit values”

Fig. 82: Retrieving currently pending limit value messages (example)



7.8 Testing digital/analog outputs

The digital/analog outputs are tested under menu item "IO Test".

Signal test "IO test"

The following signals can be set and/or tested:

- Analog output for K-value
- Analog output temperature ("Temp")
- Relay for device malfunction ("Fault")
- Relay for maintenance request ("Maintenance Req.")
- Relay for limit value ("Limit")



NOTICE: The maintenance signal must have been activated to test the digital and analog outputs and to set the values.

- ▶ In the menu, set the maintenance signal [see "Activating Maintenance mode", page 76.](#) or
- ▶ password prompt before setting the value, as shown, [see "Switching the maintenance signal on/off", page 76.](#)



If the password is set to enable a function, all further settings can be changed within 30 minutes without having to enter the password again.

7.8.1 Testing the analog output for the K-value

Fig. 83: Setting and checking the rated current of the analog output for the "k"-value

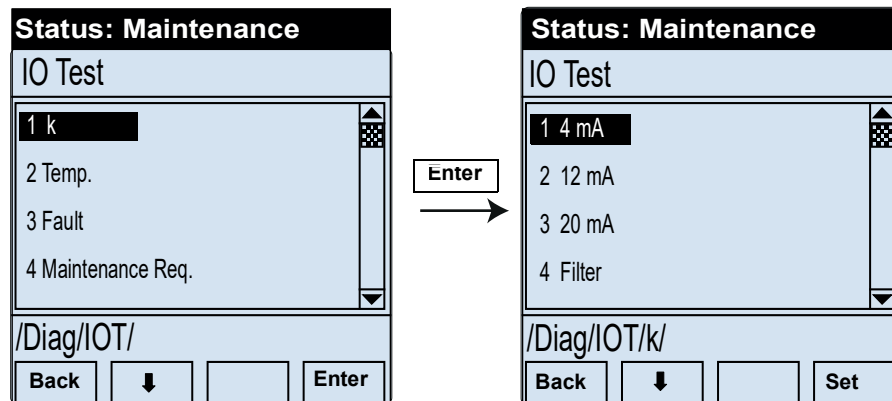

- ▶ Pressing the "Set" button outputs the value at the analog output.
- ▶ It is now possible to check at the analog output or in the control station whether the K-value is displayed at 4 mA .



Submenu item "Filter" is required in connection with the test tool and is described in the Section "Maintenance", [see "Visibility test with VIS test tool", page 89](#)



The rated current set on the analog output can be reset using "Maint" -> "inactive". After 30 minutes, the VISIC50SF switches back automatically to measuring mode, [see "Activating the setting range via menu item "Maint"", page 54.](#)

7.8.2 Testing the analog outputs for temperature

Description, [see "Testing the analog output for the K-value", page 80](#)

7.8.3 Testing the “Fault” relay with submenu item “Fault”

Maintenance mode must be activated.

Fig. 84: Enabling the Fault relay

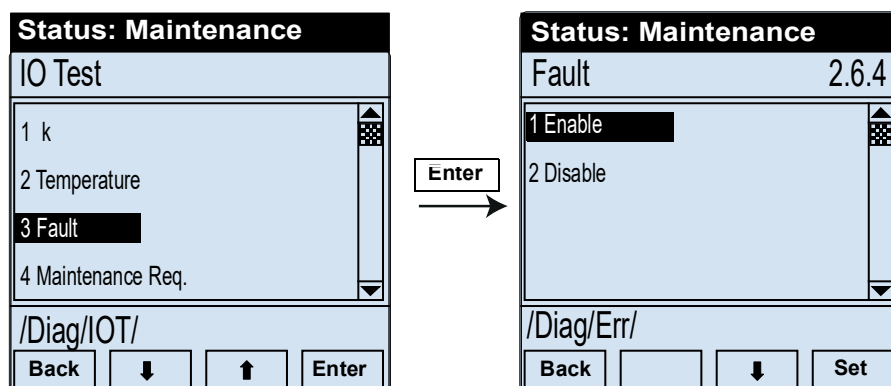

- ▶ Pressing the “Set” button enables the relay.
- ▶ It is now possible to check on the relay or in the control station whether the maintenance relay has been enabled.

7.8.4 Testing the “Maintenance Request” relay with submenu item “Maintenance Req.”

Maintenance mode must be activated.

The relay for maintenance request is set the same as the relay for malfunction.

7.8.5 Testing the relay “Limit value”

Maintenance mode must be activated.

Fig. 85: Activating the limit value relay

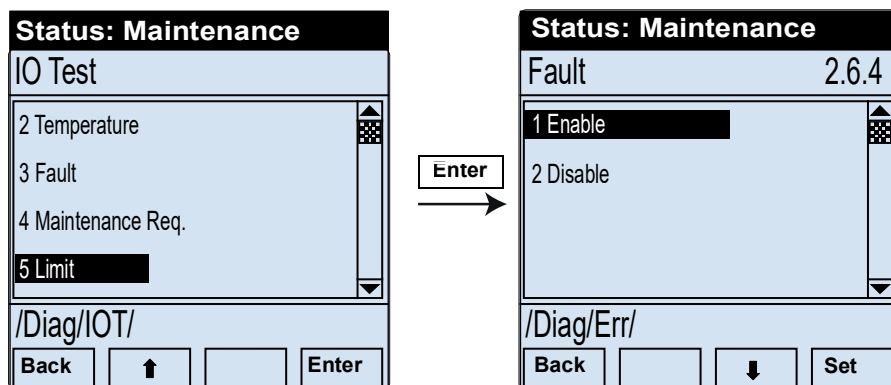

- ▶ Pressing the “Set” button enables the relay.
- ▶ It is now possible to check on the relay or in the control station whether the limit value relay has been enabled.

7.9 Performing settings on the device with menu item “Configuration”

The following settings can be performed via menu item “Configuration”:

- Select language (7 languages), see “Selecting the menu language”, page 74
- Scale AO
- PROFIBUS ID
- Limit value



NOTICE: The maintenance signal must be activated to change settings.

- ▶ In the menu, set the maintenance signal, see “Activating Maintenance mode”, page 76. or
- ▶ Password prompt before setting the values, “Changing numerical parameters”, page 75

7.9.1 Scaling analog outputs with menu item “Scale AO”

Enter the value for the analog output in the submenu item “Scale AO”. The valid value is between 15/km ... 150/km.

Fig. 86: Scaling the analog output for visibility

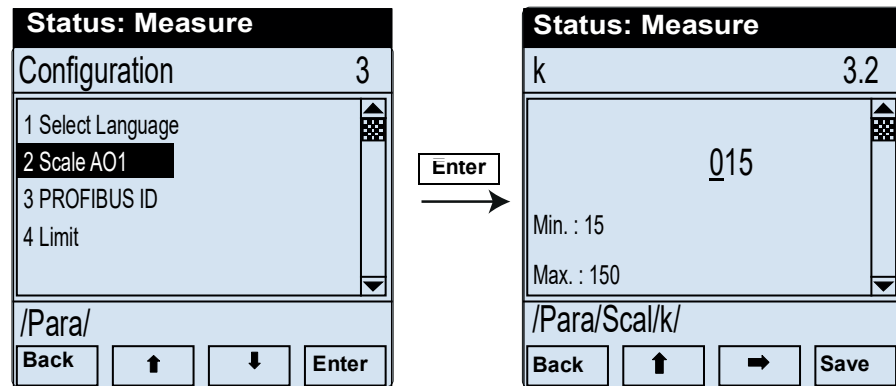

The selected scaling value is confirmed with button “Save”.

7.9.2 Setting the PROFIBUS address in “PROFIBUS ID”

The configured address is assigned to the VISIC50SF after a restart when the device is connected as “slave” in a PROFIBUS-DP system. Submenu item “PROFIBUS ID” serves to manage the PROFIBUS address. The valid address range is between 0 ... 125.

Arrow buttons: Incrementing and decrementing the digits.

“Arrow right”: Next digit is activated.

Fig. 87: Entering the PROFIBUS address

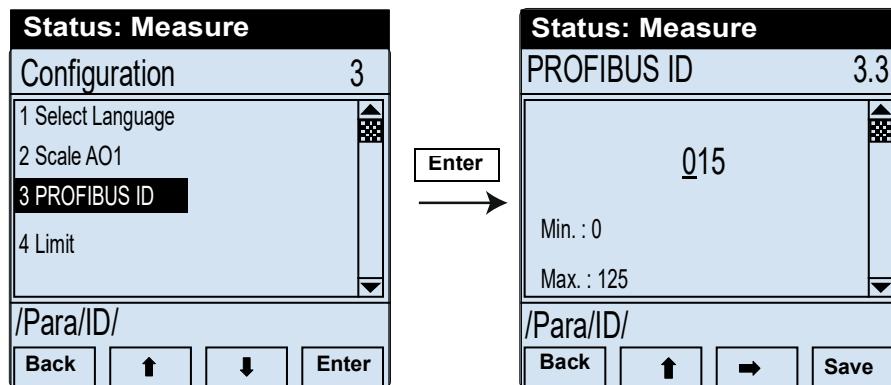

NOTICE: The new address is only active after a system restart.

7.9.3 Setting limit values in the “Limit” menu item

The following limit values are set in the menu item:

- K-value
- Gradient K-value
- Temp.
- Gradient Temp

Fig. 88: Setting the limit value for visibility

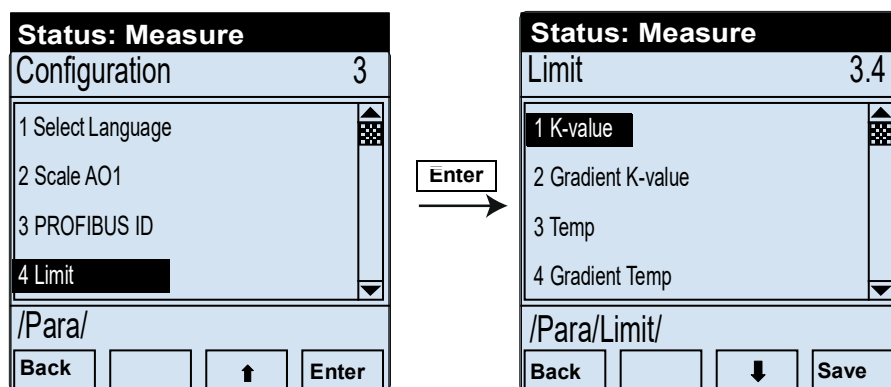

7.9.3.1 Setting the limit value for the visibility value (K-value) using “K-value”

The visibility limit value for output of an alarm is set in the submenu item “Limit K-value”.
Default value for limit K-value: 15/km

Fig. 89: Setting the limit value for the visibility value (K-value) using “K-value”

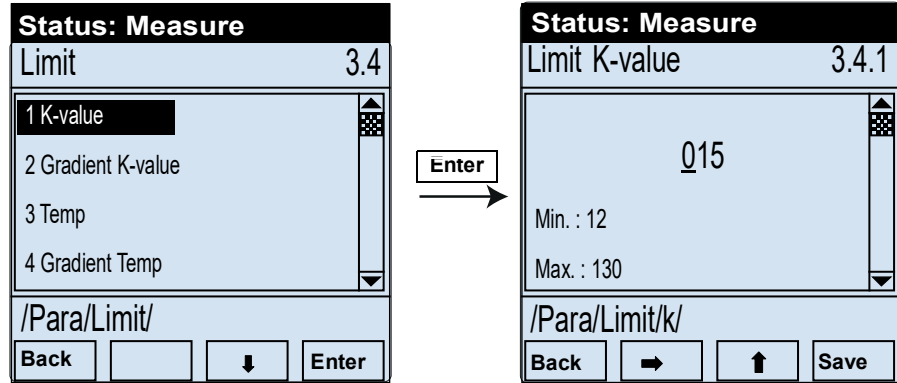

+i The entered value is confirmed with button “Save”.

7.9.3.2 Setting the limit value for the increase rate of the visibility using “Gradient K-value”

Default value: 000

Fig. 90: Setting the gradient limit value for visibility

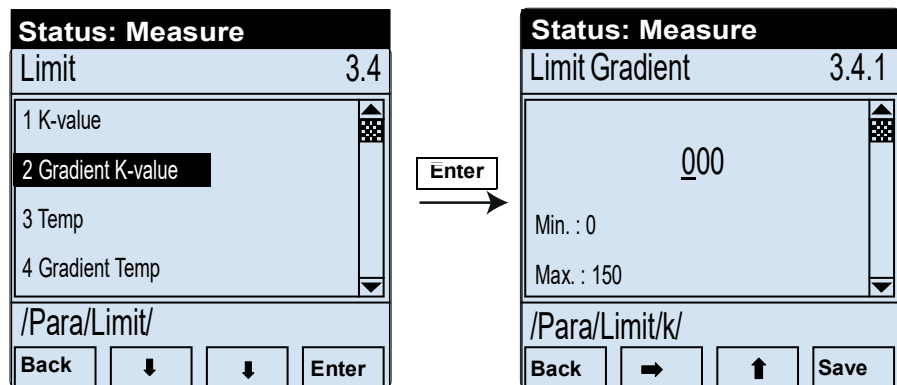

+i The entered gradient value is confirmed with button “Save”.

7.9.3.3 Setting the limit value for temperature value using “Temp”

The temperature limit value for output of an alarm is set in the submenu item “Temp”.
 Default value: 00

Fig. 91: Setting the limit value for temperature

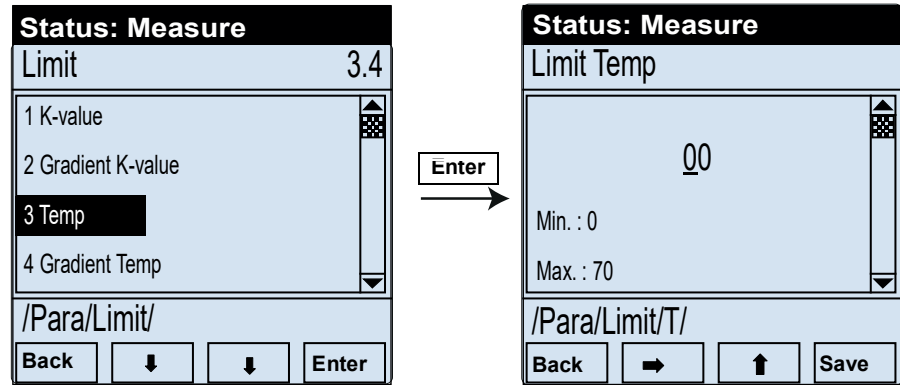

+i The entered temperature limit value is confirmed with button “Save”.

7.9.3.4 Setting the limit value for the increase rate of the temperature using “Gradient Temp”

Default-Wert: 000

Fig. 92: Setting the gradient limit value for the increase of temperature

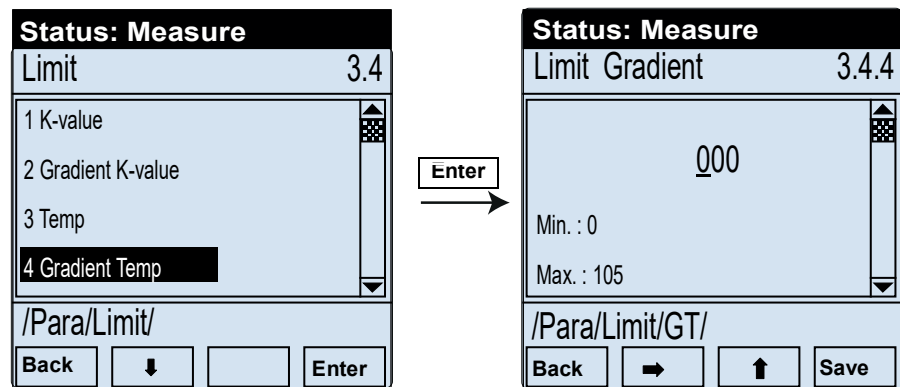

+i The entered gradient value is confirmed with button “Save”.

8 Shutdown

8.1 Technical knowledge necessary for shutdown

Shutdown may only be performed by trained technicians or an Endress+Hauser Service technician. Comply with the applicable tunnel regulations.

8.2 Safety information on shutting down

**WARNING: Risk of burns on the VISIC50SF with fog dissipation**

Inner side: The heating element can heat up to 90 °C.

Outer side: Can heat up to 80 °C in the vicinity of the inlet openings.

- ▶ Avoid touching the heating element without protective gloves.

**WARNING: Preventive measures for operating safety**

The VISIC50SF is normally used together with control technology.

- ▶ Ensure shutting down the VISIC50SF cannot lead to any danger or hindrance to traffic.

8.3 Preparations for shutdown

- ▶ Inform all concerned
- ▶ Disable/deactivate safety devices
- ▶ Clarify measuring point access (tunnel closure, lifting platform ...)

8.4 Switch-off procedure

The VISIC50SF can be switched off by interrupting power supply. There is no switch-off procedure to be observed.

8.5 Protective measures for shutdown device

- ▶ Store and transport the VISIC50SF in the original packaging.
- ▶ Pay attention to storage conditions. More information, see [“Technical data”, page 106](#).

8.5.1 Measures for short-term shutdown

- ▶ Observe the storage conditions of the measuring unit and the control unit.

8.6 Transport

**NOTICE: Damage to the VISIC50SF, the control unit and the connection unit**

The VISIC50SF and the connection unit/control unit can be damaged when dropped or through heavy impacts during transport.

- ▶ Use the delivery cartons for transport.

**NOTICE: Damage to the measuring unit through ESD**

When the measuring unit is transported separately (e.g., returning for repair or spare parts delivery), ESD caused by incorrect packaging can lead to severe damage to the electronics.

- ▶ Always transport the measuring unit in the ESD protected packaging provided.

8.7 Disposal



The following subassemblies contain substances that may have to be disposed of separately:

- *Electronics*: Capacitors
- *Display*: Liquid of LC display

The device can easily be disassembled into its components for disposal at appropriate raw material recycling facilities.

- ▶ Dispose of electronic components as electronic waste.

9 Maintenance

9.1 Necessary technical knowledge for maintenance work

Maintenance going beyond the tasks described here must be performed by authorized technicians only.

9.2 Safety instructions for maintenance work



NOTICE: Risk of erroneous device function when using wrong spare parts.

- ▶ Use original Endress+Hauser spare parts only.
-



WARNING: Hazard by voltage.

- Live parts are accessible when the device is open!
- ▶ Switch the supply voltage off before opening the device.
 - ▶ Only use suitable, insulated tools.
-



WARNING: Risk of accidents caused by missing safety precautions

- ▶ Before starting any maintenance work on the device, make sure that all tunnel-specific safety precautions have been taken.
-

9.3 Maintenance

9.3.1 VISIC50SF maintenance

Regular maintenance: 1 per year.

9.3.1.1 *Clean device inside and outside*



NOTICE: Avoid contamination of the measuring unit when opening

- ▶ Clean outer surfaces of device before opening.
-



NOTICE: Preventive measures against ESD

- The VISIC50SF may be maintained only by an expert.
- ▶ Observe the applicable ESD Guidelines.
-

- ▶ Clean the outside of the VISIC50SF with a damp cloth before opening.
- ▶ Ensure the air inlet openings are not blocked.
- ▶ Clean the inside of the cover.
- ▶ Then carefully clean the inside of the device with a clean cloth.

9.3.1.2 *Clean optics*Fig. 93: *Cleaning optical interfaces*

Tools required
 1 x Allen key
 (ball head SW4)
 1 x cotton swab

- ① Receiver unit
- ② Sender unit
- ③ Aperture
- ④ Light trap
- ⑤ Protective tube
- ⑥ Cylinder screw M5

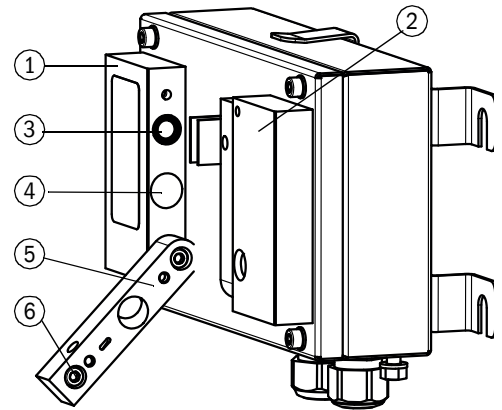

- 1 Loosen cylinder screw (6) at the upper end of the protective tube.
- 2 Open the protective tube.
- 3 Clean the optical interfaces and optical beam path in the protective tube with a cotton swab.
- 4 Close the protective tube and fasten the cylinder screw again.
- 5 Repeat the procedure on the opposite side.
- 6 Clean the light trap.

9.3.1.3 *Visibility test with VIS test tool*

A K-value test tool is available to check the visibility value.

- One test tool in value range $k = 0 \dots 150 / \text{km}$ (test set, Part No. 2075601)

Fig. 94: *Test tool for checking and readjusting the visibility value***Procedure**

- 1 Using the Allen key SW4, unscrew the two screws on the enclosure cover, take the cover off and insert it in the fixture provided.
- 2 When the enclosure cover is opened, the VISIC50SF changes to operating state Fault.
- 3 Unscrew and fold open the measuring unit.

Fig. 95: Open VISIC50SF

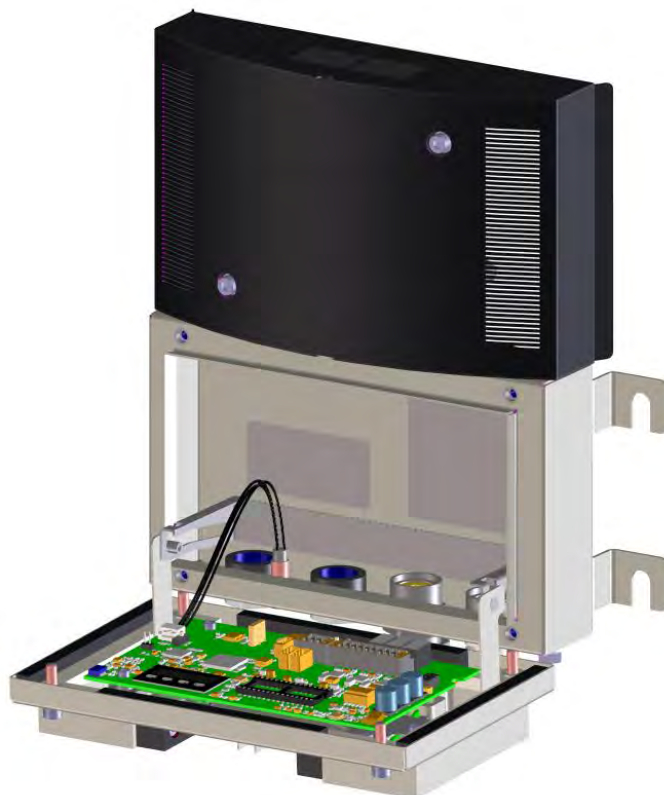

4 Switch to Maintenance mode via the display:

Fig. 96: Activating the setting range via menu item "Maint"

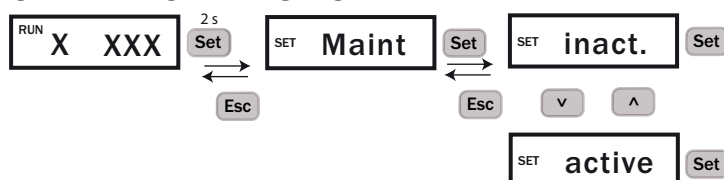

+i Mode "active" is reset to "inactive" after 30 minutes.

+i The malfunction relay is activated when mode "active" is set. The Status LED is red, the analog outputs output 1 mA and the field bus interfaces signal an error. The Maint LED on the main board lights up green.

5 Tip measuring unit up.

6 Insert the test tool between sender and receiver and check for correct seat.

Fig. 97: Test tool positioning

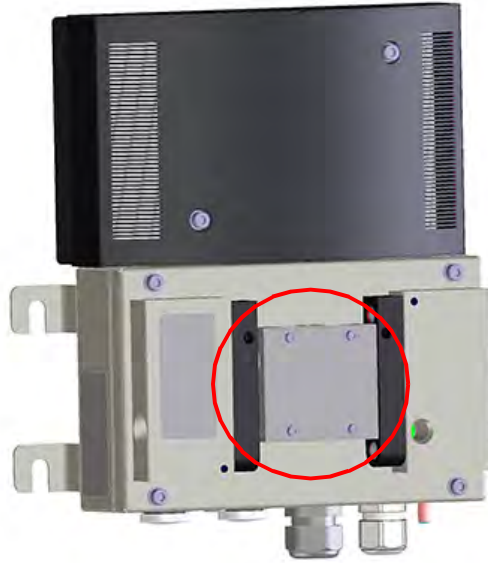

- 7 The test tool shows the rated value.
- 8 Open the measuring unit again and read the actual value on the display.
- 9 Allowed deviations:
 - From actual value: $\pm 2\%$ of measuring range end value (MBE)
i.e., MBE = 150/km, permissible deviation $\pm 3/$ km.
- 10 If the actual value is within the tolerance, remove the test tool and set the Maintenance mode to inactive again.
- 11 Close the device and attach enclosure cover.

Actual value outside tolerance limits

- 1 Clean all optical interfaces on the device and on the test tool.
- 2 Check that the test tool is inserted correctly.
- 3 Repeat the test
- 4 The actual value is still outside the tolerance limit.
- 5 Execute readjustment, see [“Readjustment of visibility measuring”, page 92](#)

Special case: Actual value is to be output via the analog output for reading

Submenu item “Filter” must be activated via the keypad on the VISIC50SF to enable transfer of the values to the central computer in the control station.

By activating submenu item “Filter”, the actual value is not only shown on the display but also output on the analog output.

Fig. 98: Menu navigation with keypad to submenu item "Filter"

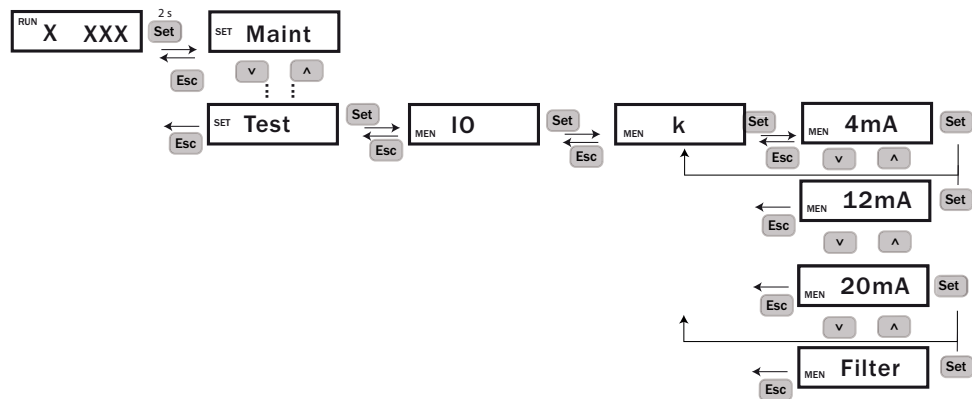

Afterwards, perform test as described above.



NOTICE: Check correct wiring of malfunction relay

The test value is shown as actual value if the malfunction relay is not connected and causes an incorrect ventilator control.

9.3.1.4 Readjustment of visibility measuring

- 1 Insert the test tool in the VISIC50SF, description see "Visibility test with VIS test tool", page 89.
- 2 Switch the VISIC50SF to Maintenance mode. Description, see "Activating the setting range via menu item "Maint"", page 90.
- 3 Select menu item "Tuning" and enter the nominal value of the filter.

Fig. 99: Menu navigation for entering the nominal value

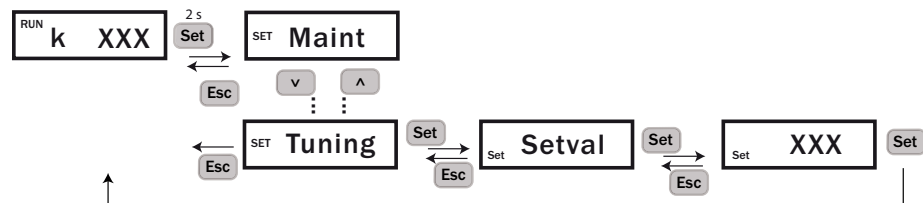

- 4 Start the readjustment via the display of the VISIC50SF, description, see "Executing device adjustment", page 67.



Adjustment procedure takes maximum 2 seconds.

- » "Ok" is output on the display after 2 seconds when the adjustment procedure is successful. The measured value is corrected with the value determined during adjustment procedure.
 - » "Fail" is output on the display after 2 seconds if an error occurs during adjustment. The currently valid value remains valid.
- 5 In an error occurs: After eliminating the cause of the error, perform the adjustment procedure again.

Possible causes for a failed adjustment

- Active the malfunction message in the VIS measurement.
- Contamination >15%.
- The determined deviation of the current measured value from the nominal value is >20%.

9.3.2 Maintenance plan

Maintenance by trained users/Customer Service of manufacturer

Maintenance interval	Maintenance work
Yearly	
✓	▶ Clean device inside and outside
✓	▶ Clean optics
✓	▶ Test analog outputs
✓	▶ Test digital outputs

 ▶ Also observe the local statutory and works regulations which apply for the individual application.

9.3.3 Tunnel cleaning

The device is protected during tunnel cleaning with enclosure rating IP6K9K.

- ▶ Set the device or the complete ventilator control to Maintenance or Manual during tunnel cleaning.

 **NOTICE: During cleaning, the measured values may not be used for smoke detection.**

9.4 When requesting Customer Service from Endress+Hauser

Request the Endress+Hauser Customer Service in writing to the responsible office 4 weeks before the planned maintenance date at the latest. Before this date, the customer must ensure:

- Safe access to, and safeguarding the mounting and workplaces in the tunnel. The tunnel/traffic lane should be closed when necessary.
- Provision of a lifting platform or a ladder and adequate lighting at the mounting locations.
- Availability of a skilled technician with knowledge of local conditions.

 Inform Service about malfunctions or potential repairs as early as possible. The Service engineer can then have the spare parts and consumables available that may be necessary for the maintenance date; and thus avoid unnecessary and expensive multiple journeys.

9.5 Spare parts



WARNING: Malfunction hazard

► Use original Endress+Hauser spare parts only.

9.5.1 Spare parts for VISIC50SF

Spare part	Part number
Measuring unit	2074558
Enclosure cover, standard	2071120
Enclosure cover with heating	2071121
Connection terminal strips ^[1]	2076810
Cable gland M20 x 1.5 D6-12	2071122
Cable gland M20 x 1.5 D10-14	2071123
Screw plug	2071124
Sender tube	2073957
Receiver tube	2073956
Status LED	2073008
PCB PROFIBUS	2073009

[1]6 and 18 pin, pluggable. Ferrules are provided for on-site wiring.



The standard enclosure cover and enclosure cover with heating cannot be swapped onsite.

9.5.2 Spare parts for connection unit

Spare part	Part number
Power supply unit	2073011
Power filter	2073012
Terminal set 1 (for TB-A1)	2073018
Terminal set 2 (for TB-A2)	2073019

9.5.3 Spare parts for TAD control unit

Spare part	Part number
Fuses, 3 x	2073020
Adapter module for display unit	2076813
Display	2076819
I/O module, analog, with connecting cable	2076818
I/O module, digital, with connecting cable	2076817

10 Clearing malfunctions

10.1 Description of device errors

The VISIC50SF switches immediately to Malfunction when a device error occurs. In operating state Malfunction, the malfunction relay opens and the three analog interfaces signal 1 mA. The digital interfaces (PROFIBUS and Modbus) have a measured value status which switches to "Bad" when an error occurs. The following Table shows the error codes displayed for possible device errors.



Information on calling up error codes on the display, see ["Calling up maintenance request and malfunction messages with menu item "Status"”, page 54](#)

Table 20: Device error coding

Code	Bit	Description	Cause	Notes for service
F_000	0	VIS error	Contam. Optic. LED fault. VIS>Spec.	Clean and restart device. Exchange measuring unit. (via Endress+Hauser Customer Service).
F_003	3	EEPROM	EEPROM Data inconsistent.	Restart. If the error is still present after a restart, call Endress+Hauser Customer Service or return the device, and specify the error code.
F_004	4	Heating	Enclosure cover not fitted because power supply interrupted -> no heating error. Heating Current Out Of Spec Heating active/inactive set falsely.	Fit the enclosure cover. Restart. If the error is still present, call Endress+Hauser Customer Service. Exchange cover. Check the activation/deactivation of the heating
F_005	5	Erroneous function of analog interfaces	Electronics defective	Restart. If the error is still present after a restart, call Endress+Hauser Customer Service or return the device, and specify the error code.
F_006	6	FPGA	FPGA Fault, ADC Overload	Restart. If the error is still present after a restart, call Endress+Hauser Customer Service or return the device, and specify the error code.
F_007	7	CPU	RAM test error Flash test error Register test error.	Call Endress+Hauser Customer Service or return the device, and specify the error code.
F_008	8	Program flow	Program flow erroneous.	Restart. If the error is still present after a restart, call Endress+Hauser Customer Service or return the device, and specify the error code.
F_009	9	Enclosure error	Enclosure cover not fitted.	Fit enclosure cover.
F_014	14	Maintenance	Maintenance active on device.	Deactivate maintenance on device, see "Activating maintenance in menu item "Maint"”, page 54



The status is always shown in plain text on the control unit display.

10.2 Description of maintenance requests

Table 21: Description of maintenance requests

Code	Bit	Description	Coding Maintenance requests	Notes for service
MRq_000	0	VIS measurement	Contamination Limit 1 Reached	▶ Clean enclosure and optics. Restart.
MRq_004	4	DO module	Communication Fault DO-Modul.	▶ Exchange DO module
MRq_005	5	AO module	Communication Fault AO-Modul.	▶ Exchange AO module
MRq_006	6	TAD	Communication Fault TAD	▶ Check connection to control unit ▶ Exchange control unit

10.3 Display of error states on the control unit

Table 22: Display of error states on the control unit

Indication	Actions
"POWER" off	▶ Check mains supply (external mains switch, mains fuses)
"FAILURE" on	▶ Check messages.
Measured values blink	
"MAINTENANCE REQUEST" on	▶ Check in menu item Diagnosis which maintenance request exists.
Measured values implausible	▶ Check whether it is possible for the measured values to reach these values in the current situation. ▶ Check device for contamination.

10.4 Further error causes

Data interruption through VISIC50SF self-test

Self-tests are performed every four hours for RAM/Flash and CPU registers. Short interruptions (between 8 μ s and 140 ms) in communication to the Modbus-RTU/control unit interface are therefore possible and can lead to transfer errors/timeouts on the Master.

11 Specifications

11.1 Compliances



VISIC50SF

The technical design of the device corresponds to the following EC Directive:

- EMC Directive 2014/30/EU
- RoHS Directive 2011/65/EU

Applied EN standards:

- EN 61326, Electrical equipment for measurement, control and laboratory use - EMC requirements

Connection unit / TAD control unit

The technical design of the device corresponds to the following EC Directive:

- Directive 2014/35/EU (Low Voltage Directive)

Applied EN standards:

- EN 61010-1, Safety requirements for electrical equipment for measurement, control and laboratory use

11.1.1 Electrical protection

- Insulation: Protection class in accordance with EN 61140.
- Insulation coordination: Overvoltage category II in accordance with EN 61010-1.
- Contamination: The device operates safely in an environment up to contamination level 2 according to EN 61010-1.

11.1.2 Standards observed

- RABT 2006
- ASTRA 2007 Fire detection in road tunnels

11.1.3 Declaration of Conformity

- CE

11.2 Dimensions

11.2.1 Dimension drawing VISIC50SF

Fig. 100: VISIC50SF dimensions (all units of measurement in mm)

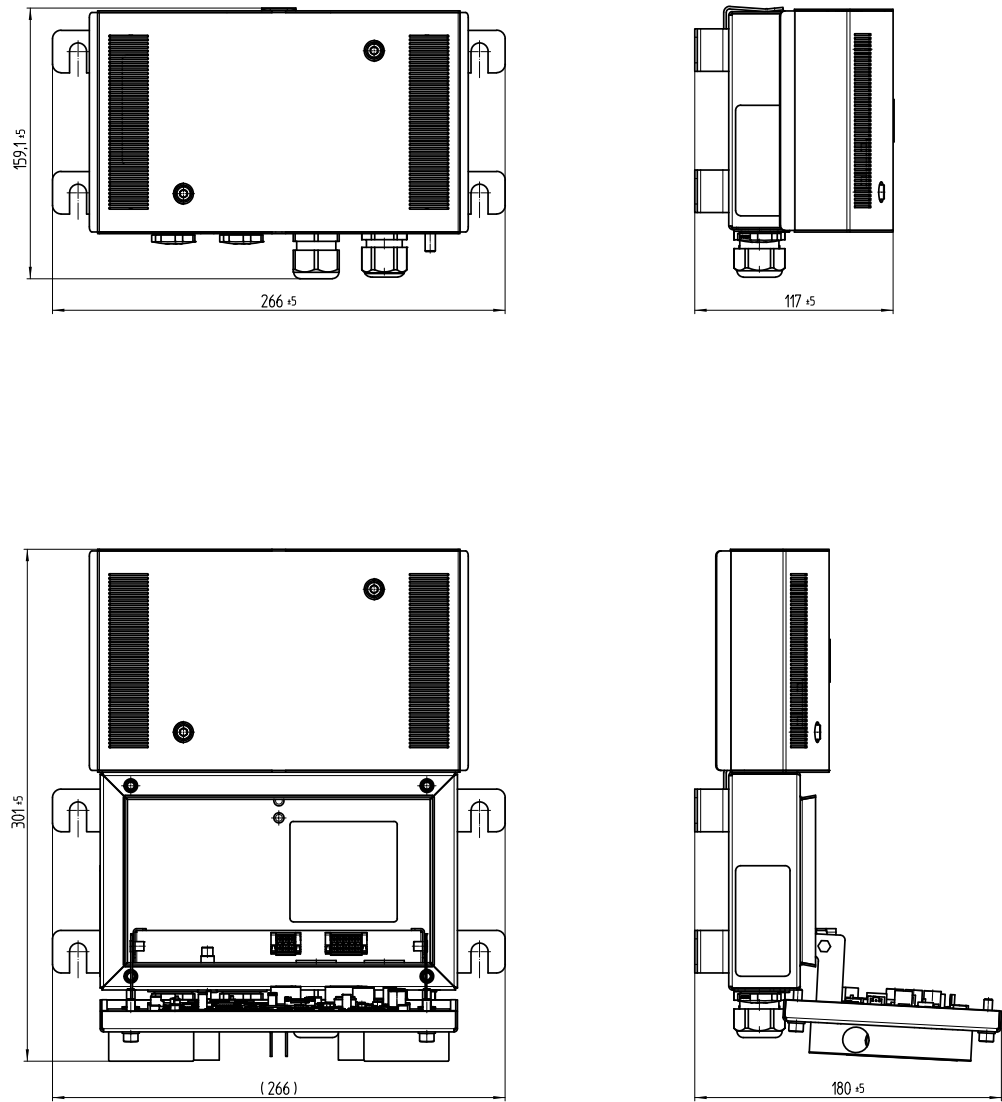

11.2.2 Dimension drawing, connection unit

Fig. 101: Dimensions of connection unit for VISIC50SF (all units of measurement in mm)

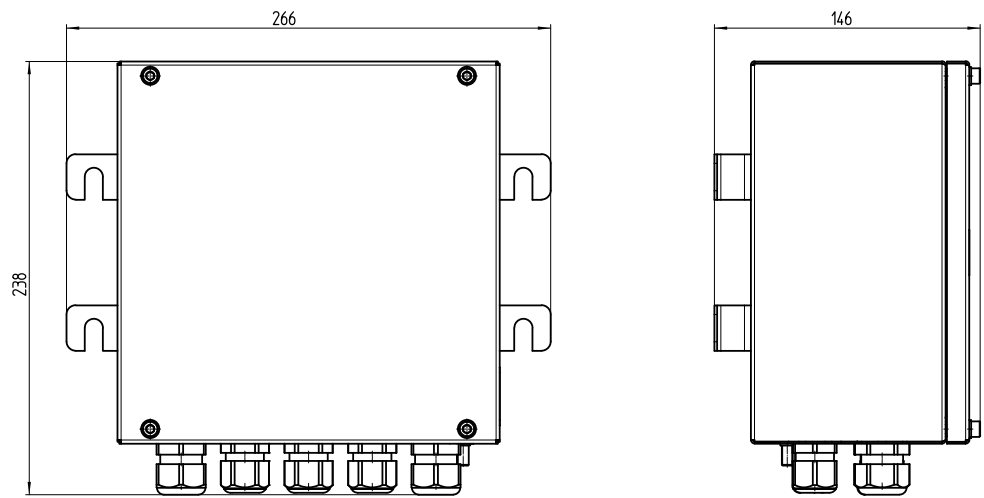

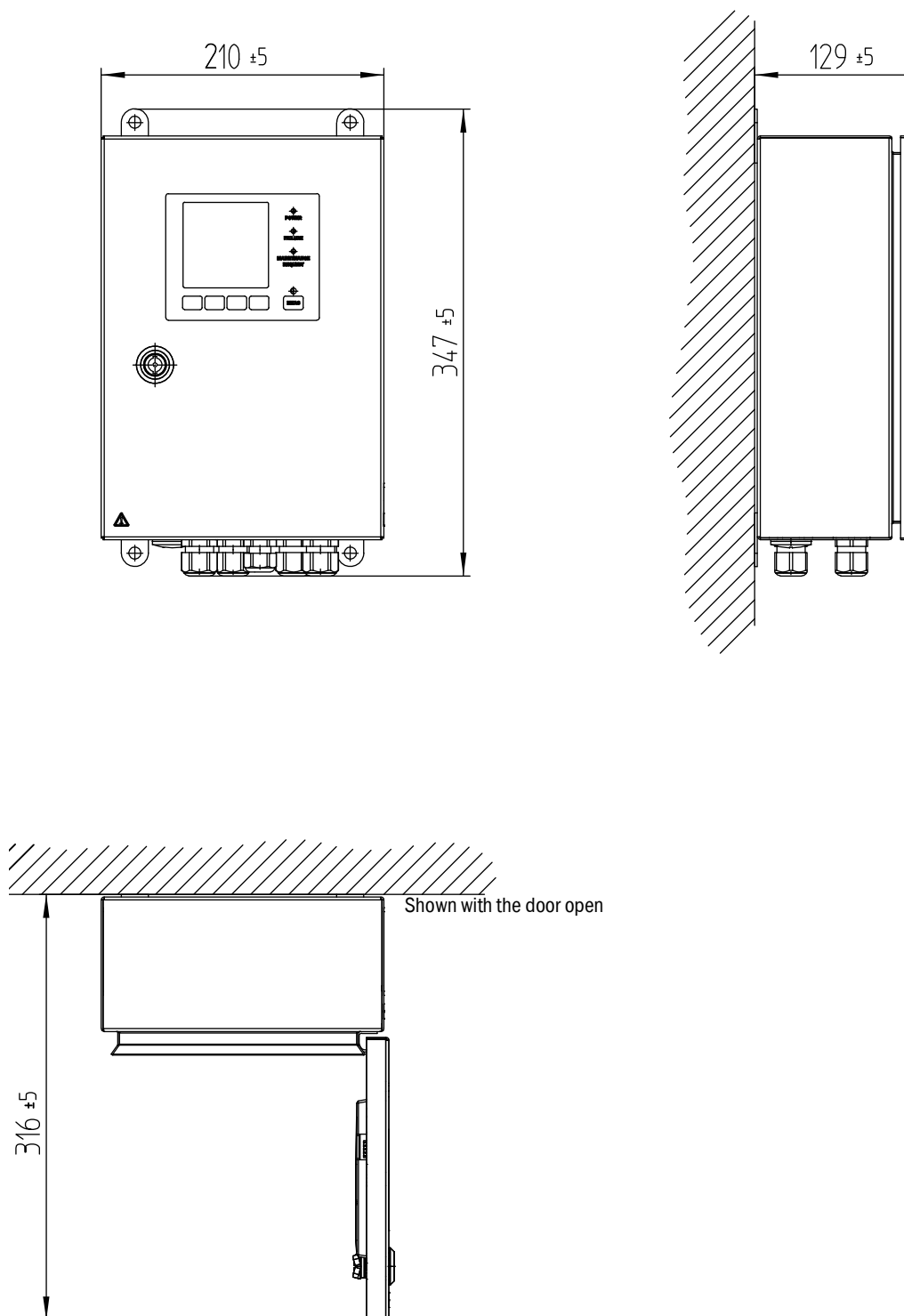
11.2.3 Dimension drawing TAD control unit*Fig. 102: Dimensions TAD control unit (all units of measurement in mm)*

11.2.4 Dimension drawing VISIC50SF ceiling mounting, not swivel-mounted

Fig. 103: Dimensions of ceiling mounting for VISIC50SF (all units of measurement in mm)

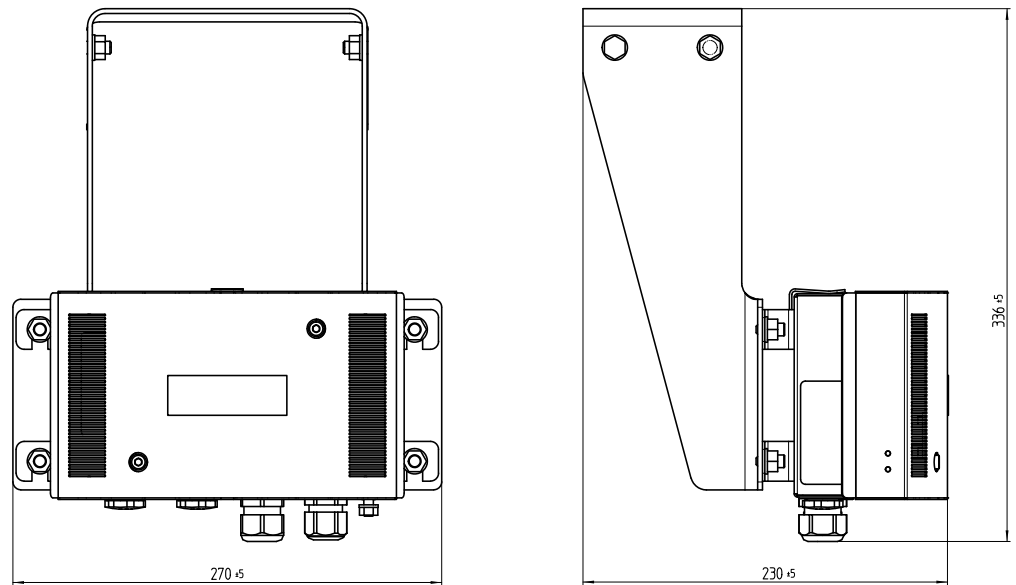

11.2.5 Dimension drawing VISIC50SF ceiling mounting, swivel-mounted

Dimensions of ceiling mounting for VISIC50SF (all units of measurement in mm)

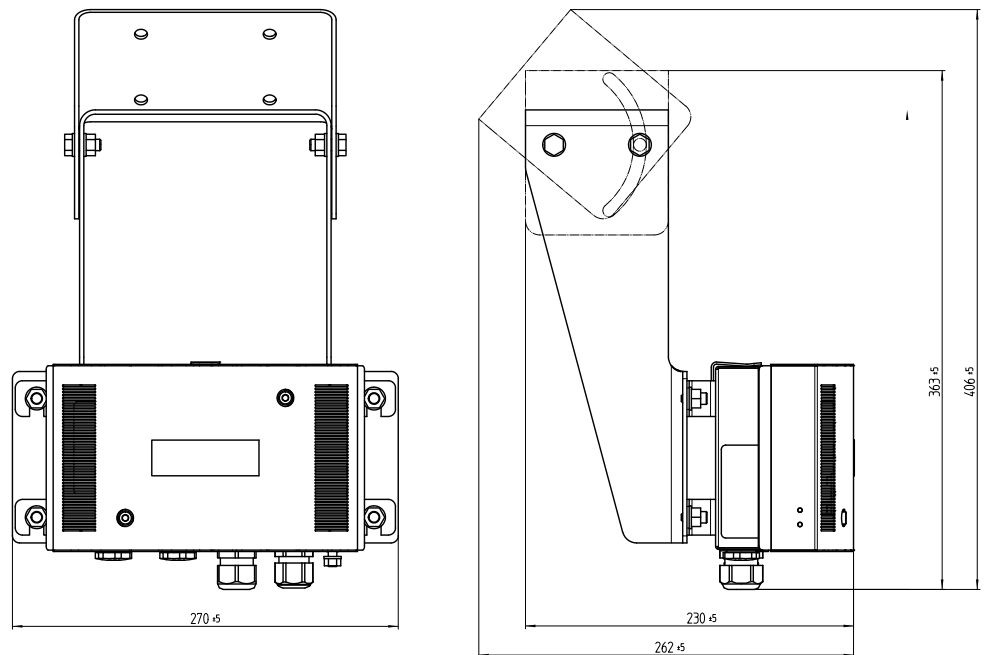

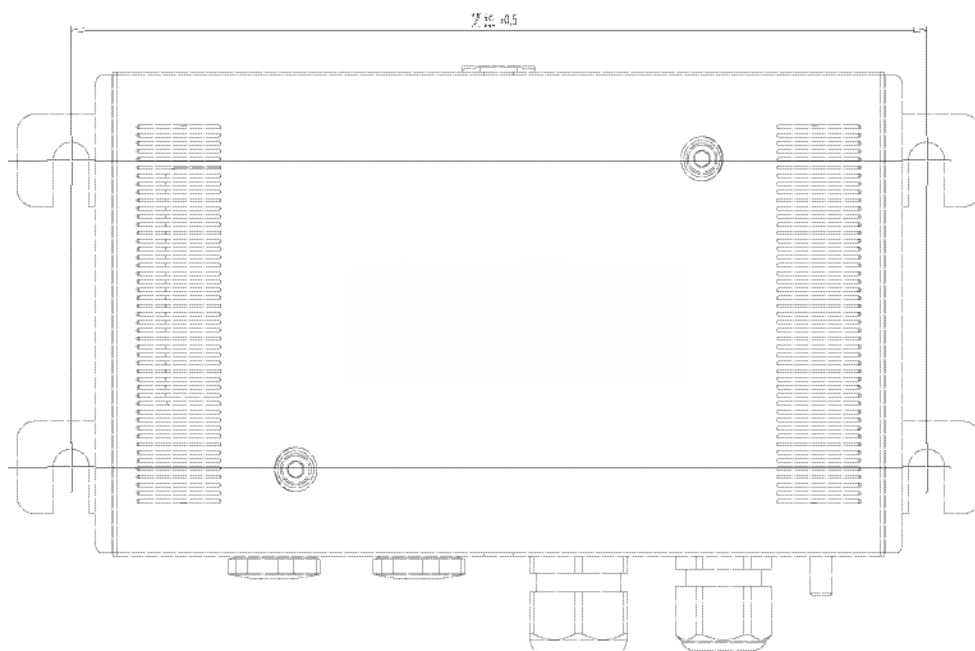
11.2.6 Drilling plan VISIC50SF*Fig. 104: Drilling plan VISIC50SF (all units of measurement in mm)*

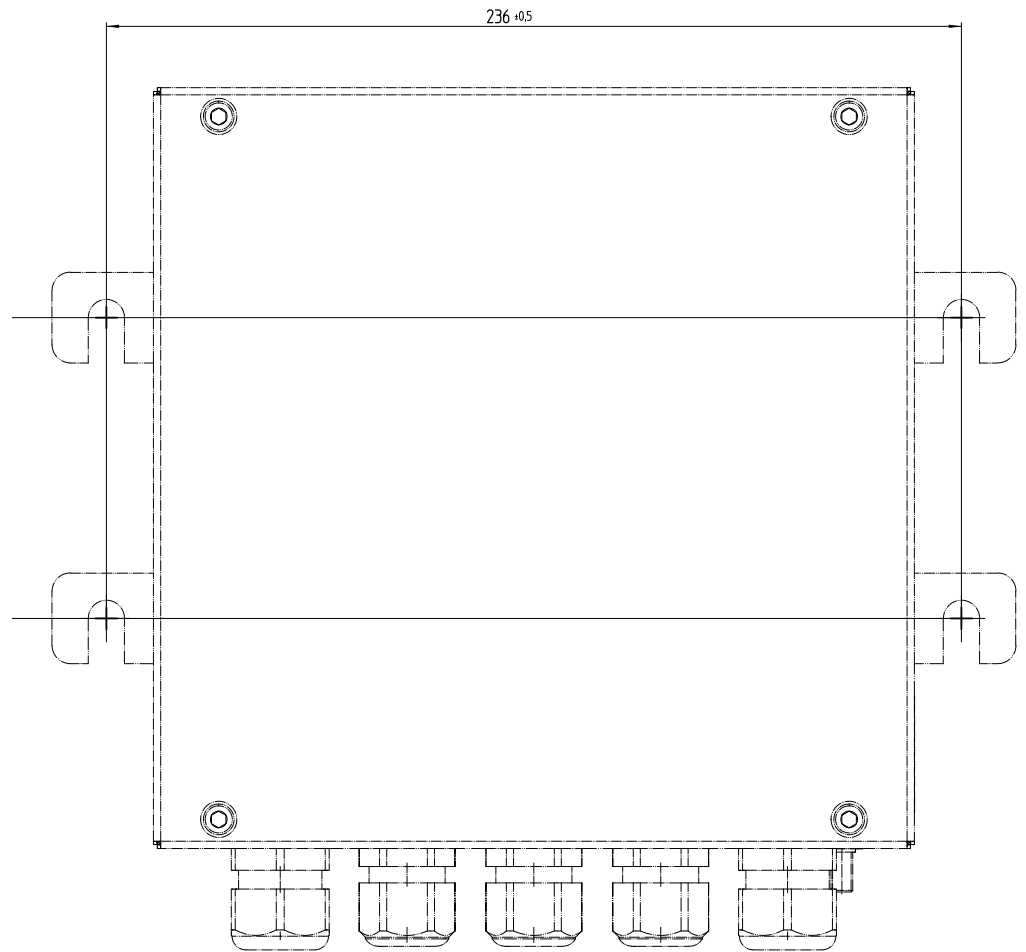
11.2.7 Drilling plan connection unit*Fig. 105: Drilling plan for control unit for VISIC50SF (all units of measurement in mm)*

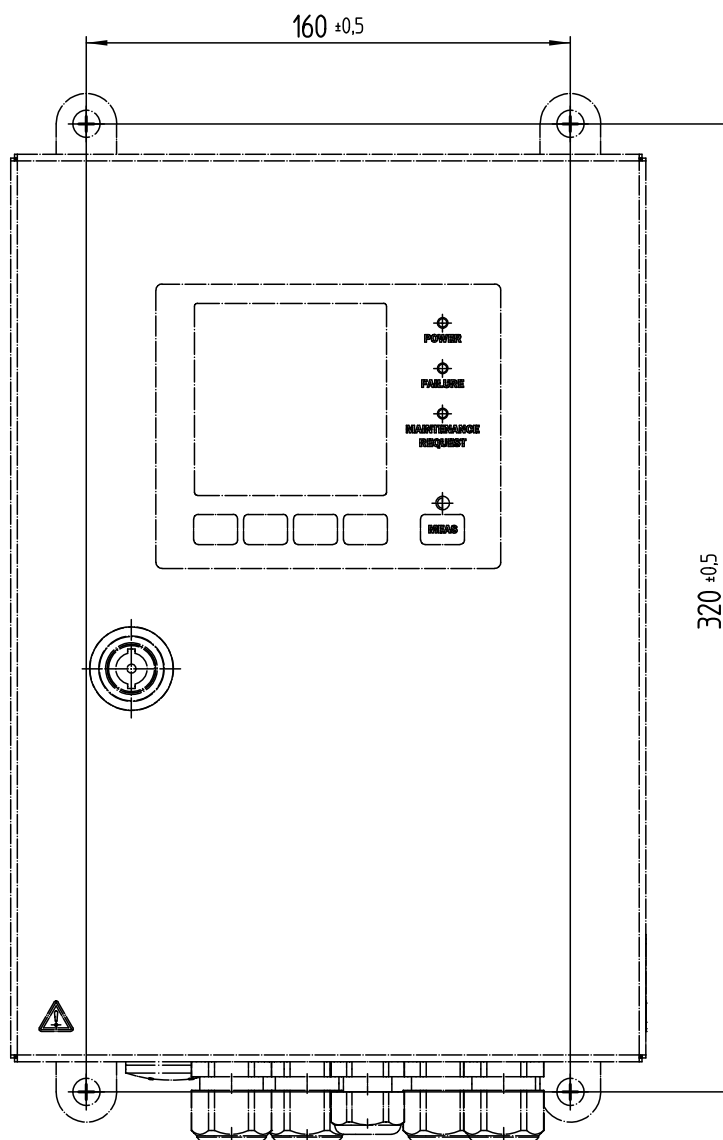
11.2.8 Drilling plan TAD control unit*Fig. 106: Drilling plan for TAD control unit for VISIC50SF (all units of measurement in mm)*

11.2.9 Drilling plan mounting plate for ceiling mounting

Fig. 107: Drilling plan mounting plate for ceiling mounting of the VISIC50SF (all units of measurement in mm)

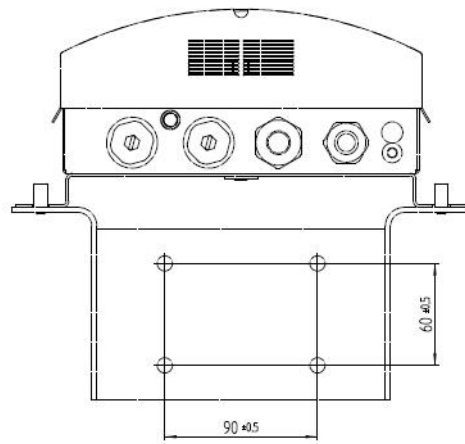

11.3 Technical data

VISIC50SF	
Use inside or outside buildings	Use in tunnel-like applications, e.g. in road tunnels, at tunnel portals, in underground car parks
Measured variables	Visibility (K-value), optional temperature measurement
Measuring principles	Scattered light forwards (K-value)
Measuring ranges	<ul style="list-style-type: none"> • Visibility (k-value): 0 km150 • Optional temperature measurement -30 .. +70 °C
Setting time t_{90}	≤ 5 s
Resolution	Visibility (k-value): 1/km
Repeat accuracy	1% of the upper measuring range value
Altitude	Max. 3,000 m (above sea level)
Ambient temperature	-20 ... +55 °C
Storage temperature	Measuring device: -30 °C ... +85 °C
Ambient pressure	860 ... 1,080 hPa
Max. relative humidity	10% ... 100% RF, non-condensing
Wet environment	Suitable for wet environmental condition.
Degree of contamination	2
Electrical safety	CE
Control functions	<ul style="list-style-type: none"> • Contamination monitoring of optics • Drift and plausibility check • Automatic self-test • Function monitoring of optional heating
Options	<ul style="list-style-type: none"> • Internal heating • Connection unit • TAD control unit • Temperature sensor
Scope of delivery	Exact device specifications and performance data of the product can deviate and depend on the respective application and customer specification.
Protection class	IP69
Analog outputs	2 outputs: 4 ... 20 mA, max. load 500 Ohm electrically isolated; short-circuit proof. Two outputs pre-assigned for smoke detection and temperature.
Analog inputs	≥ 48 V DC
Digital outputs	3 relay contacts: 0.5 A, 24 W Pre-assigned for malfunction, limit value and maintenance request
Interfaces	2 x RS-485
Bus protocol	<ul style="list-style-type: none"> • Integrated: Modbus-RTU • Optional: PROFIBUS DP-V0
Display	LC-Display, Status LEDs: <ul style="list-style-type: none"> • Green: Operation • Red: Fault • Yellow: Maintenance request
Input and operating	Function buttons, single-line LC-Display

Dimensions (W x H x D)	266 mm x 159 mm x 117 mm (details, see dimensional drawing, see "VISIC50SF dimensions (all units of measurement in mm)", page 98)
Weight	≤ 2.8 kg
Material, media contact	Stainless steel 1.4571
Installation position ^[1] /installation angle/swivel angle:	<ul style="list-style-type: none"> • Wall assembly, vertical up to 45° wall inclination • Ceiling mounting with adapter
Power supply	Voltage: 18 ... 28 V DC, voltage supply with optional connection unit and/or TAD control unit
	Overvoltage category: II
	Power input: Max. 1
	Power input: <ul style="list-style-type: none"> • Without heating: ≤ 5 W • With heating: ≤ 20 W
	No battery

[1] Allowable enclosure tilt during operation

Connection unit	
Protection class	IP66 and IP6K9K
Dimensions	266 mm x 238 mm x 146 mm (details, see dimension drawing, see "Drilling plan VISIC50SF", page 102)
Weight	<2.8 kg
Material, media contact	Stainless steel 1.4571
Electric connection (optional)	Voltage: 85 ... 264 V AC
	Frequency: 45 ... 65 Hz
	Power input: 0.1 A
	Temperature class A: -40 ... +85 °C
	Cross-section: 3 x 1.5 mm ²

TAD control unit	
Protection class	IP66
Dimensions	210 mm x 129 mm x 347 mm (details, see dimensional drawing, see "Dimensions TAD control unit (all units of measurement in mm)", page 100)
Weight	5 kg
Material, enclosure	Stainless steel 1.4571
Electric connection (optional)	Voltage: 88 ... 264 V AC
	Frequency: 47 ... 63 Hz
	Power input: 15 VA
Optional I/O modules	
Analog outputs	4 outputs: 4 ... 20 mA, 500 Ω, electrically isolated
Digital outputs	3 outputs: <ul style="list-style-type: none"> • 30 V DC, 2 A
Digital inputs	1 input: OFF Voltage Level: 1 V DC ON Voltage Level: +4 ... 30 V DC Input Impedance: 3 kΩ Overvoltage Protection: ± 35 V DC

8029837/1DPO/V2-0/2023-07

www.addresses.endress.com
