

Operating Instructions

VISIC100SF

Tunnel Air Quality Sensors



Described Product

Product name: VISIC100SF

Manufacturer

Endress+Hauser SICK GmbH+Co. KG
Bergener Ring 27
01458 Ottendorf-Okrilla
Germany

Legal information

This work is protected by copyright. Any rights derived from the copyright shall be reserved for Endress+Hauser SICK GmbH+Co. KG. Reproduction of this document or parts of this document is only permissible within the limits of the legal determination of Copyright Law. Any modification, abridgment or translation of this document is prohibited without the express written permission of Endress+Hauser SICK GmbH+Co. KG. The trademarks stated in this document are the property of their respective owner.

© Endress+Hauser SICK GmbH+Co. KG. All rights reserved.

Original document

This document is an original document of Endress+Hauser SICK GmbH+Co. KG.



Symbols and document conventions

Warning symbols



Hazard (general)



Hazard by voltage



Hazard for the environment/nature/organic life

Warning levels and signal words

DANGER

Risk or hazardous situation which *will* result in severe personal injury or death.

WARNING

Risk or hazardous situation which *could* result in severe personal injury or death.

CAUTION

Hazard or unsafe practice which *could* result in personal injury or property damage.

NOTICE

Hazard which *could* result in property damage.

Information Symbols



Important technical information for this product



Important information on electric or electronic functions



Supplementary information



Link to information at another place

Data integrity

Endress+Hauser SICK GmbH+Co. KG uses standardized data interfaces, such as standard IP technology, in its products. The focus here is on product availability and features.

Endress+Hauser SICK GmbH+Co. KG always assumes the integrity and confidentiality of data and rights affected in connection with the use of the products are ensured by the customer.

In all cases, the customer is responsible for the implementation of safety measures suitable for the respective situation, e.g., network separation, firewalls, virus protection and patch management.

Contents

1	Important information	9
1.1	About this document	9
1.2	Responsibility of user	9
1.3	Intended use	10
1.3.1	Purpose of the device	10
1.3.2	Product identification	10
1.3.3	Installation location.....	10
2	Product description	11
2.1	Features of the VISIC100SF	11
2.2	Device versions.....	12
2.2.1	Standard components: VISIC100SF visibility measurement (K-value).....	12
2.2.2	Optional equipment.....	13
2.2.3	Measuring principle.....	17
2.2.4	Interior view - VISIC100SF	17
2.3	Interfaces	20
2.3.1	Analog interfaces characteristics	20
2.3.2	Digital interfaces properties	20
2.3.3	Modbus®-RTU interface characteristics.....	20
3	Mounting and electrical installation	21
3.1	Safety notes	21
3.2	Material required	21
3.3	Preparing the installation location	22
3.4	Mounting.....	23
3.4.1	Scope of delivery	23
3.4.2	Mounting the VISIC100SF.....	23
3.4.3	Mounting the connection unit (optional).....	25
3.4.4	Mounting the TAD control unit (optional)	26
3.4.5	Mounting and commissioning of the gas sensors (optional)	26
3.5	VISIC100SF wiring	29
3.5.1	Safety notes	29
3.5.2	Connecting the LED.....	30
3.5.3	Wiring of analog outputs, relay outputs and voltage supply	32
3.5.4	Bus interface wiring	33
3.5.5	Shielding.....	33
3.5.6	Connection unit wiring	35
3.5.7	TAD control unit wiring.....	36
3.6	Connections	37
3.6.1	Standard version	37
3.6.2	VISIC100SF with connection unit	37
3.6.3	VISIC100SF connections with TAD control unit	37

4	Commissioning	38
4.1	Commissioning, step by step.....	38
4.2	Bus connections.....	40
4.3	Modbus® RTU (integrated in the VISIC100SF standard version)	40
4.3.1	Modbus® RTU data format.....	40
4.3.2	Modbus® RTU baud rates	40
4.3.3	Read Holding Register (0x03)	41
4.3.4	Modbus® RTU Read Coil (0x01).....	42
4.4	PROFIBUS DP-V0 (optional)	42
4.4.1	PROFIBUS addressing	42
4.4.2	PROFIBUS DP-V0 baud rates.....	43
4.4.3	Access via GSD file	43
4.4.4	Coding of visibility measured value status	44
4.5	RS-485 - topology and bus termination	45
4.6	Stub line length for terminal box on all RS-485 bus systems.....	45
5	Operation	47
5.1	Operating and display elements.....	47
5.1.1	Display with keypad in VISIC100SF	47
5.1.2	Reset button and “Maint” LED.....	47
5.1.3	Display unit in the TAD control unit	47
5.2	Operating states.....	48
5.2.1	Checking the operating state (visual control).....	48
5.2.2	Checking malfunction messages	48
5.3	Checking the analog outputs.....	48
5.3.1	Displaying measured values	48
5.4	Operating functions.....	48
5.5	Status messages.....	48
5.5.1	Malfunction messages	48
5.5.2	Maintenance request messages.....	48
6	VISIC100SF menu navigation	49
6.1	Menu structure.....	49
6.1.1	Short description: Entering settings on the keypad	49
6.2	Measuring operation mode “RUN”	50
6.3	“SET” mode	51
6.3.1	Structure and sequence of “SET” mode submenu items	52
6.3.2	Activating maintenance in menu item “Maint”	53
6.3.3	Calling up maintenance request and malfunction messages with menu item “Status”	53
6.3.4	Maintenance request for gas sensors in submenu item “NxtMRq”	53
6.3.5	Calling-up the operating duration in submenu item “Uptime” ...	54
6.3.6	Calling up the software version in submenu item “SwVers”	55
6.4	Connecting the bus systems.....	56
6.4.1	Setting the RS-485 interface with submenu item “Bus”	56

6.5	Setting bus parameters.....	57
6.5.1	Setting the PROFIBUS address in “PB ID”	57
6.5.2	Setting the Modbus® address in “MB ID”	58
6.5.3	Setting the Modbus® data transfer format with menu item “MB Par”.	58
6.5.4	Setting the Modbus® baud rate with menu item “MB BdR”	59
6.6	Testing digital/analog outputs and gas sensors	60
6.6.1	Signal test “IO test”	60
6.6.2	Assigning analog outputs with menu item “IOMap”	63
6.6.3	Scaling analog outputs	64
6.6.4	Output visibility as “K-value” or “µg”	65
6.6.5	Activating/deactivating the external temperature sensor (optional)	65
6.6.6	Activating/deactivating the heating (optional).....	66
6.6.7	Device adjustment using submenu item “Tuning”	66
7	TAD control unit menu navigation	67
7.1	Basic features	67
7.2	Main functions	67
7.3	Switch-on procedure.....	67
7.3.1	Characteristics of the heating up phase	67
7.4	Operating elements	68
7.4.1	LEDs.....	68
7.4.2	Function buttons	69
7.5	Starting operation	70
7.5.1	Initialization phase	70
7.5.2	Measuring screen.....	71
7.5.3	Displaying the Main menu	72
7.5.4	Selecting the menu item.....	72
7.5.5	Returning to the measuring screen	72
7.5.6	Selecting the menu language.....	72
7.5.7	Setting the display contrast	73
7.5.8	Changing numerical parameters (password input)	73
7.6	Activating Maintenance mode	74
7.7	Main menu item “Diagnosis”	75
7.7.1	Maintenance requests of gas sensors: “Next Maintenance”	76
7.7.2	Retrieving the operating duration: “Uptime”	76
7.7.3	Retrieving device information with “Device Info”	77
7.7.4	Retrieving the state of peripheral equipment with submenu item “Peripheral”	77
7.7.5	Error messages/maintenance requests with “Messages”	78

7.8	Testing digital/analog outputs	79
7.8.1	Testing the analog output AO1.....	79
7.8.2	Testing the analog outputs AO2 - AO4.....	80
7.8.3	Testing the “Fault” relay with submenu item “Fault”	80
7.8.4	Testing the “Maintenance Request” relay with submenu item “Maintenance Req.”	80
7.9	Performing settings on the device with menu item “Configuration”	80
7.9.1	Scaling analog outputs with menu item “Scale AO”	81
7.9.2	Assigning analog outputs “AO Mapping”	82
7.9.3	Setting the PROFIBUS address in “PROFIBUS ID”.....	83
7.9.4	Conversion visibility/dust concentration with menu item “Conversion µg”	84
7.9.5	Activating/deactivating temperature measurement with menu item “Temp.”	85
8	Shutdown	86
8.1	Technical knowledge necessary for shutdown	86
8.2	Safety information.....	86
8.3	Preparations for shutdown	86
8.4	Switch-off procedure.....	86
8.5	Protective measures for shutdown device.....	86
8.5.1	Measures for short-term shutdown	86
8.6	Transport	87
8.7	Disposal	87
9	Maintenance.....	88
9.1	Technical knowledge, required.....	88
9.2	Safety notes	88
9.3	Maintenance	89
9.3.1	VISIC100SF maintenance	89
9.3.2	Maintenance plan.....	93
9.3.3	Tunnel cleaning.....	93
9.4	When requesting Customer Service from Endress+Hauser.....	93
9.4.1	Exchanging the measuring unit.....	93
9.5	Spare parts.....	94
9.5.1	Consumable parts/operating materials	94
9.5.2	Spare parts for VISIC100SF	94
10	Clearing malfunctions.....	95
10.1	Description of device errors	95
10.2	Description of maintenance requests.....	96
10.3	Display of error states on the TAD control unit	96
10.4	Further error causes	96

11	Specifications.....	97
11.1	Compliances	97
11.1.1	Electrical protection	97
11.1.2	Standards observed	97
11.1.3	Declaration of Conformity	97
11.2	Dimensions	98
11.3	Technical Data	103

1 Important information

1.1 About this document

- These Operating Instructions describe:
 - Device components
 - Installation
 - Operation
 - Maintenance work required
- It contains important safety information for safe operation.

1.2 Responsibility of user

- ▶ Read the Operating Instructions before putting the VISIC100SF into operation.
- ▶ Observe all safety information.
- ▶ If anything is not clear: Please contact Endress+Hauser Customer Service.

Designated users

The VISIC100SF may be operated by qualified persons only who, based on their device-specific training and knowledge of the device as well as knowledge of the relevant regulations, can assess the tasks given and recognize the hazards involved.

Correct use

- This Manual presumes that the VISIC100SF has been delivered as specified during project planning (e.g., for use in a tunnel) and with the relevant delivery state of the VISIC100SF (→ delivered System Documentation).
- If you are not sure whether the VISIC100SF complies with the planned configuration or the delivered System Documentation:
 - ▶ Please contact Endress+Hauser Customer Service.
- The VISIC100SF should only be used as described in these Operating Instructions, [see “Purpose of the device”, page 10](#). The manufacturer assumes no responsibility for any other use.
- Maintenance work should be performed as prescribed in this Manual.
- Do not attempt any work on or repairs to the VISIC100SF unless described in this Manual.
- Do not modify the VISIC100SF in any way unless specifically instructed and permitted to do so by the manufacturer.
- Use only original spare parts and wear and tear parts from Endress+Hauser.

Failure to observe these precautions could result in:

- Voiding the manufacturer's warranty.
- Causing the VISIC100SF to become dangerous.

Special local conditions

- ▶ Follow all local laws, regulations, and company policies applicable at the installation location.

Retention of document

These Operating Instructions:

- Must be available for reference.
- Must be conveyed to new owners.

1.3 Intended use

1.3.1 Purpose of the device

The VISIC100SF measures the visibility in tunnels and at the tunnel portals. When appropriate gas sensors have been fitted, the concentrations of CO, NO and NO₂ in the tunnel can be determined at the same time visibility is measured.



The VISIC100SF can be equipped with maximum two gas sensors.

1.3.2 Product identification

Product name:	VISIC100SF
Manufacturer:	Endress+Hauser SICK GmbH+Co. KG Bergener Str. 37 · 01458 Ottendorf-Okrilla · Germany

The type plate is located on the side on the rear enclosure panel.

1.3.3 Installation location

- In a tunnel
- On tunnel portals
- In basement garages
- Generally in applications similar to tunnels for measuring visibility and gas concentrations

2 Product description

2.1 Features of the VISIC100SF

- ▶ Simultaneous or individual measurement of
 - a) Standard:
 - Visibility (K-value)
 - b) Optional
 - CO concentration
 - NO concentration
 - NO₂ concentration
 - Combination of two gas concentrations possible
- ▶ Measuring visibility with fog dissipation (optional).
- ▶ Compact design with low space requirements.
- ▶ Already calibrated ex factory, no readjustment required onsite (Plug & Measure).
- ▶ Scope of delivery with or without connection unit.
- ▶ Scope of delivery with or without TAD control unit.
- ▶ Keypad and single-line display in the measuring unit to
 - Display values when the device is open.
 - Control diagnosis and maintenance.
 - Assign device addresses when using bus wiring.
- ▶ Status LED signals error-free operation (green), maintenance request (yellow) and malfunction (red).
- ▶ Standard: 3 analog outputs and 2 digital outputs, 1 Modbus® RTU.
- ▶ Optional: PROFIBUS DP-V0

Fig. 1: VISIC100SF application example

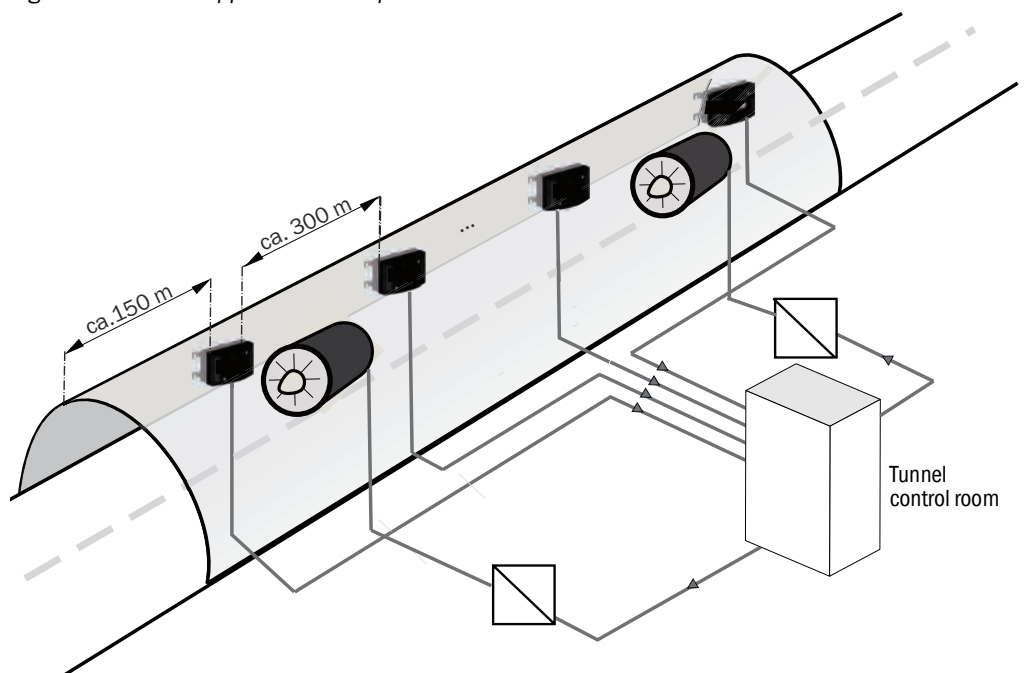

- Option:
- Connection unit and/or TAD
 - Fog dissipation: Version with heating

2.2 Device versions

2.2.1 Standard components: VISIC100SF visibility measurement (K-value)

Fig. 2: VISIC100SF sensor



- ① Enclosure cover
- ② Inlet opening for air to be measured
- ③ Rear enclosure panel with mounting bracket
- ④ Status LED
- ⑤ Screw plugs for operation without gas sensors
- ⑥ Electrical screw fitting for cable (10 ... 14 mm)
- ⑦ Electrical screw fitting for cable (6 ... 12 mm)
- ⑧ Connection for functional grounding

2.2.2 Optional equipment

2.2.2.1 Gas sensor for measuring CO, NO or NO₂

The type plate is stuck on the gas sensor.

Fig. 3: Gas sensor type plate

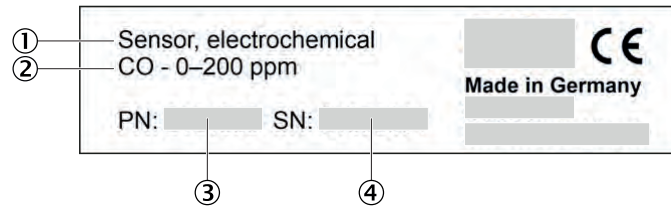

- ① Designation
- ② Measured component
- ③ Item number
- ④ Serial number

Fig. 4: Gas sensors CO, NO, NO₂

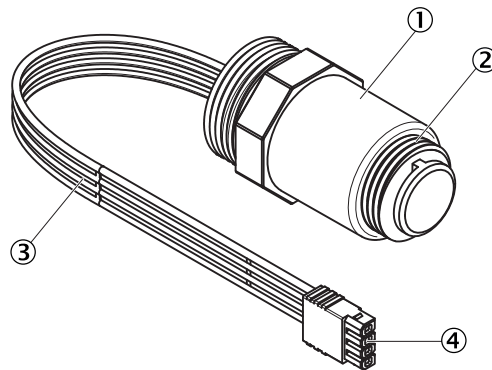

- ① Enclosure
- ② M20 x 1.5 mm thread
- ③ 4-pin connecting cable
- ④ 4-pin connector

The CO, NO and NO₂ sensors can only be distinguished by their type plate, [see Fig. 3: “Gas sensor type plate”](#)

2.2.2.2 Connection unit

2 variants:

- TB-A1: Connection unit for reconnection of cables. It contains:
 - 10 connection terminals for reconnection of on-site cables.
- TB-A2: Connection unit to connect the VISIC100SF to the power voltage. It contains:
 - Power supply filter, connection terminals and a power supply unit.



Specifications concerning stub lines, see [“Stub line length for terminal box on all RS-485 bus systems”](#), page 45, must always be adhered to when the VISIC100SF and the associated connection unit are part of a bus system.

Fig. 5: Connection unit with 24 V voltage supply for the sensor



- ① Enclosure cover
- ② Rear enclosure panel with mounting bracket
- ③ Electrical screw fittings for cables:
 - 3 x 6 ... 11 mm
 - 2 x 10 ... 14 mm
- ④ Grounding



Ready-made connection cables are available for both variants. (Further details on connection cables, see [“Installation material”](#), page 21).

2.2.2.3 TAD control unit

2 variants:

- TAD100 standard control unit:
 - Connection to VISIC100SF analog: 3 x 4 ... 20 mA and 2 x relay
 - Connection to VISIC100SF via RS-485 interface (Endress+Hauser bus)
 - Display unit
 - Electrical connection to power voltage
- TAD100 control unit with optional I/Os:
 - Connection to VISIC100SF via RS-485 interface (Endress+Hauser bus)
 - Display unit
 - Electrical connection to power voltage

Fig. 6: TAD control unit



① Enclosure cover

② Display unit

Electrical screw fittings for cables:

③ 4 x 6 ... 12 mm (M20 x 1.5)

④ 1 x 5 ... 10 mm (M16 x 1.5)

2.2.2.4 Fog dissipation (cover with integrated heating element)

Endress+Hauser provides a variant with a heating element in the cover for fog dissipation.

Fig. 7: VISIC100SF cover with heating element for fog dissipation

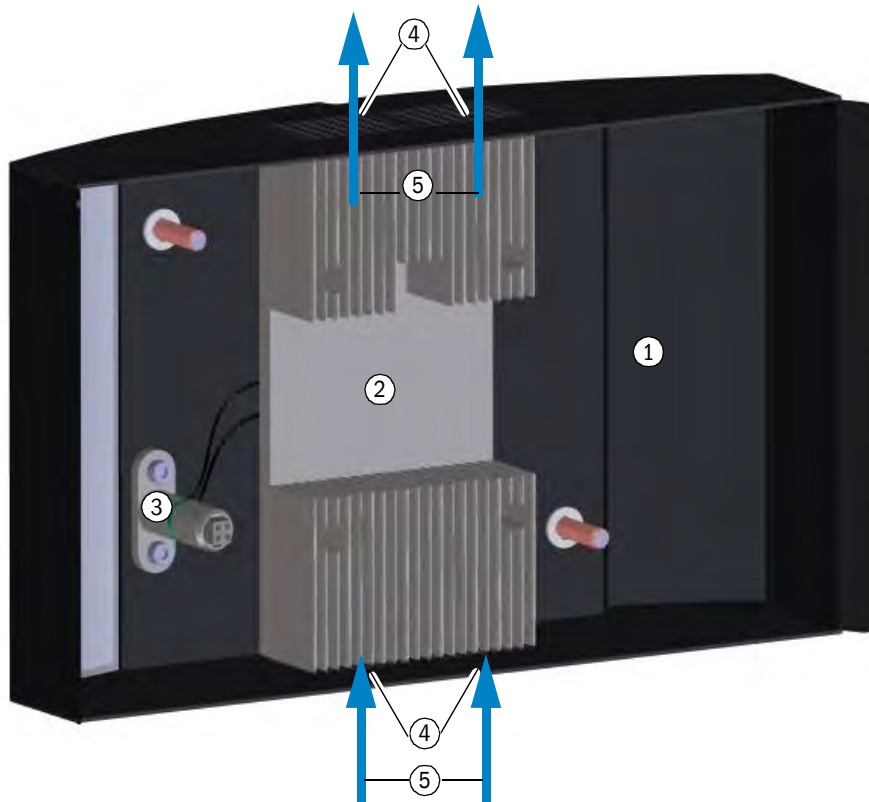

- ① Enclosure cover
- ② Heating element
- ③ Electrical contacts for heating element
- ④ Inlet opening for air to be measured
- ⑤ Flow direction of air to be measured

- +i** The heating element is integrated in the VISIC100SF cover and cannot be retrofitted onsite.
- +i** The side openings for the air to be measured are closed off on the VISIC100SF version with fog dissipation.
- +i** If the cover is not placed on the measuring unit, error message F004 (heating) is active because the voltage supply to the heating is interrupted.

2.2.2.5 Bus interface: PROFIBUS DP-V0, Modbus® RTU

The VISIC100SF is delivered with the following bus interface depending on the configuration:

- Modbus® RTU (standard)
- PROFIBUS DP-V0 (option)

- +i** Modbus® RTU is *not* available when a TAD control unit is used.

2.2.3 Measuring principle

- Visibility: Scattered light measurement
- CO, NO, NO₂: Electrochemically

2.2.4 Interior view - VISIC100SF

Fig. 8: Interior view - enclosure, complete

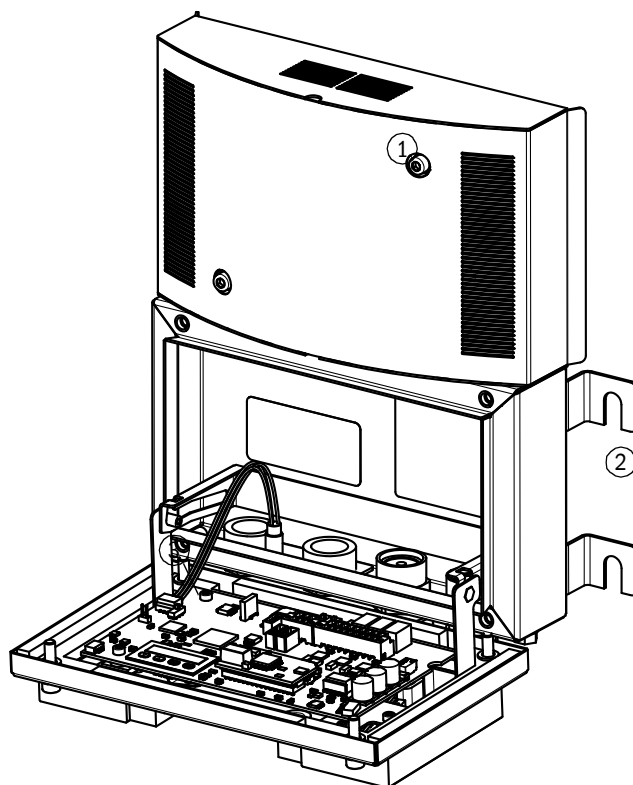

- ① Enclosure cover
- ② Rear enclosure panel with mounting bracket
- ③ Measuring unit



The enclosure cover can be held on the rear enclosure panel for maintenance purposes.

Fig. 9: Interior view - enclosure cover without heating

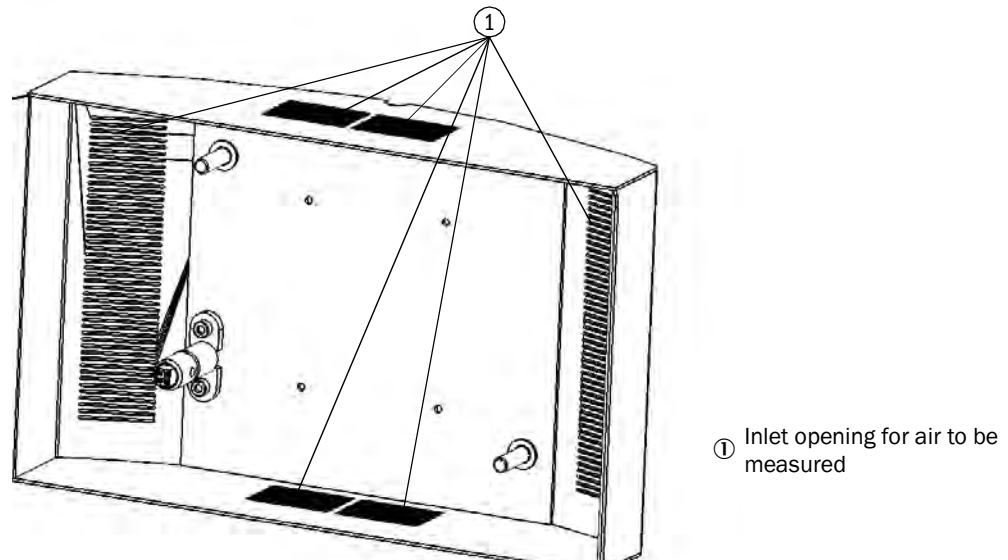
**Interior view - enclosure cover with heating**

see “VISIC100SF cover with heating element for fog dissipation”, page 16.

Interior view - measuring unit

Fig. 10: Measuring unit - circuit board with display and keypad

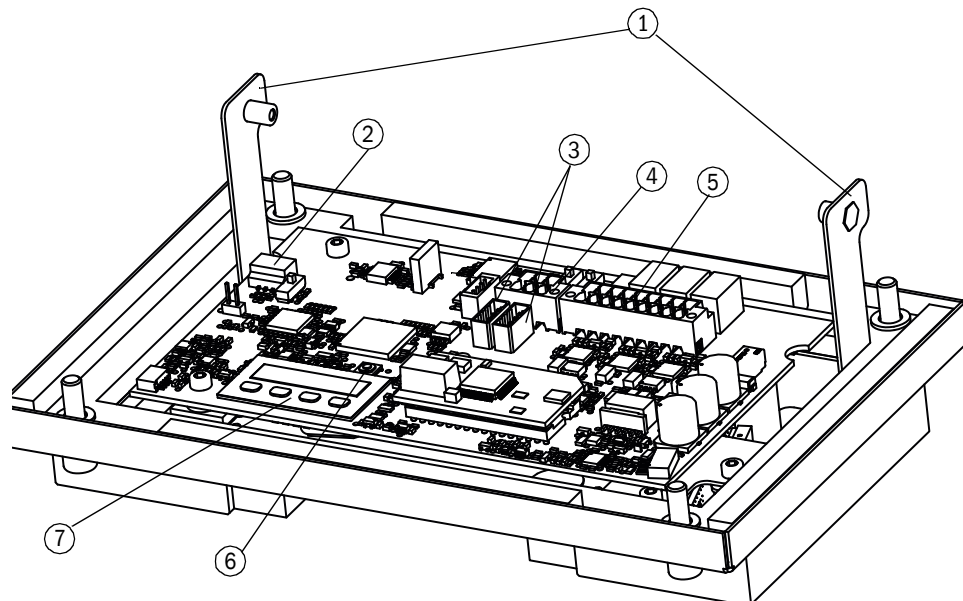

- ① Hinge fixture
- ② Slot for Status LED
- ③ Slots for gas sensors
- ④ Wiring block for bus connections (RS-485)
- ⑤ Wiring block for 24 V and signals
- ⑥ Reset button
- ⑦ Display with keypad

Fig. 11: Measuring unit

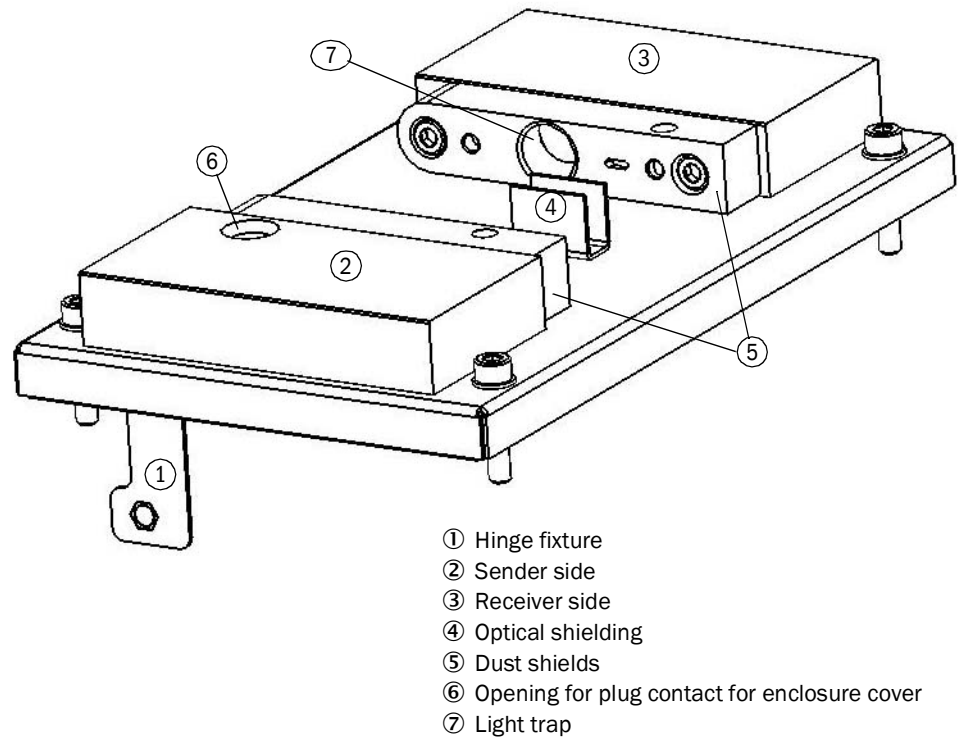
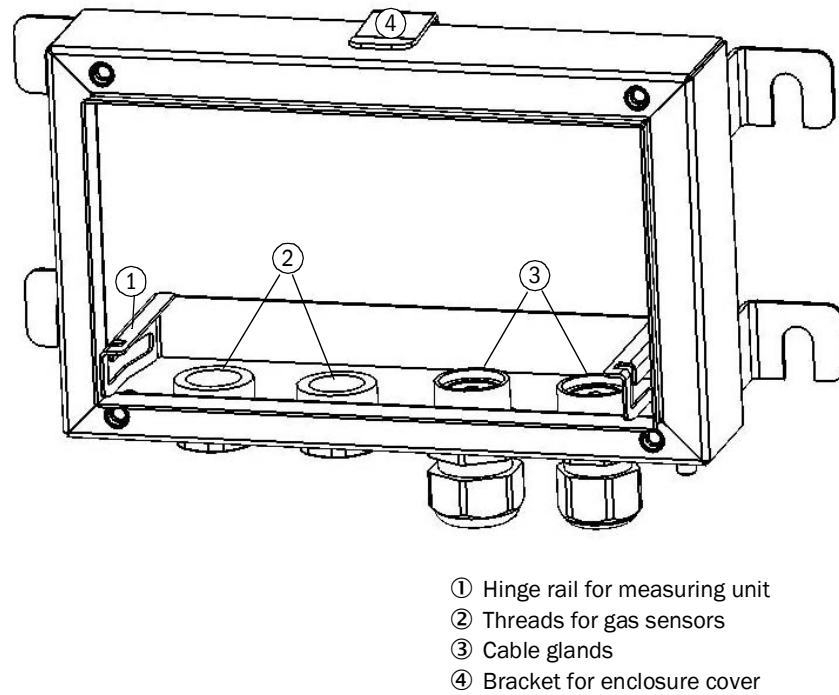

Fig. 12: Interior view - rear enclosure panel



2.3 Interfaces

- Standard:
 - 3 analog interfaces for measured value output
 - 2 digital interfaces for maintenance requests or malfunction messages
 - RS-485: Either Modbus® RTU or Endress+Hauser bus to the TAD control unit
- Optional:
 - PROFIBUS DP-V0

2.3.1 Analog interfaces characteristics

The interfaces of the VISIC100SF provide 4 ... 20 mA signals. If an error exists on the VISIC100SF or when the measured value underflows the lower measuring range limit, the relevant analog output switches to 1 mA. If the upper measuring range limit is exceeded, the relevant analog output switches to 23 mA.



The switch to 1 mA only affects the analog output with a device error. All other analog outputs continue to output a measured value between 4 ... 20 mA.



The analog interface can drive a load resistance of up to 500 Ohm. The refresh rate is ≤ 1.6 seconds.

The following formula shows the relation between the output current and the respective measured variable:

$$\text{Measured variable gas conc. without signifi.} = \frac{\text{Output current} - 4 \text{ mA}}{\text{Ausgangsstrom} - 4 \text{ mA}} \times \frac{\text{full scale value}}{\text{Messbereichsendwert}}$$

2.3.2 Digital interfaces properties

If a device error is detected or a measured value is outside the measuring range, an error is signaled via the malfunction relay. If no device error exists, the malfunction relay is in a closed state. The relay opens when an error occurs.

2.3.3 Modbus®-RTU interface characteristics

see “Modbus® RTU (integrated in the VISIC100SF standard version)”, page 40.

3 Mounting and electrical installation

3.1 Safety notes



NOTE: Preventive measures for operating safety

The VISIC100SF is normally used together with control technology.

- ▶ Should a malfunction occur on the VISIC100SF, ensure this cannot lead to conditions dangerous for traffic or can hinder traffic.



NOTE: The system operator is responsible for the operating safety of the device when integrated in a system

- ▶ Observe the connection values from Section, see “Technical Data”, page 103, when integrating the device in a system.



WARNING: Preventive measures during mounting and installation

- ▶ Observe the generally applicable regulations for protective clothes in tunnels.
- ▶ Observe the regulations for personal safety (e.g., lane closure, warning devices).



NOTE:

Mounting of the VISIC100SF may be carried out by qualified persons only who, based on their device-specific training and knowledge of the device as well as knowledge of the relevant regulations, can assess the tasks given and recognize the hazards involved.



NOTE:

Original Endress+Hauser mounting material is recommended for safe mounting of the VISIC100SF.



CAUTION: The connection unit and the TAD control unit do not have independent main power switches.

- ▶ Ensure the following before installation in accordance with EN 61010:
 - A main power switch is available in the tunnel.
 - Service personnel can easily access the main power switch.
 - The main power switch is marked as disconnecting device.

3.2 Material required

Table 1: Mounting material

Material required	Item number	Required for
Mounting kit	2071034	VISIC100SF, connection unit or TAD control unit see “VISIC100SF drilling plan (all units of measurement in mm)”, page 100. see “Dimensions of control unit for VISIC100SF (all units of measurement in mm)”, page 100
Drilling plan Drilling template		

Table 2: Installation material

Material required	Item number	Required for
Cable, 2 m (12 x 0.75 mm ²)	2076476	Analog cables for connection of VISIC100SF - connection unit or TAD control unit.
Cable, 5 m (12 x 0.75 mm ²)	2076477	
Cable, 10 m (12 x 0.75 mm ²)	2076478	
Cable, 20 m (12 x 0.75 mm ²)	2076479	
Onsite cables		Robust material, suitable for outdoor applications, halogen-free, screened; wires 12 x 0.75 mm ² ; Connection VISIC100SF to connection unit, TAD control unit or tunnel control room.

Material required	Item number	Required for
Cable, 2 m (3 x 2 0.75 mm ²)	2076481	Cables for RS-485 interface.
Cable, 5 m (3 x 0.75 mm ²)	2076482	
Cable, 10 m (3 x 0.75 mm ²)	2076483	
Cable, 20 m (3 x 0.75 mm ²)	2076484	
Ferrules Length: Min. 10 mm; max. 20 mm		For onsite lines. To prepare flexible leads. Note: Delivered in enclosure.

Table 3: Tools

Tools required	Characteristics	Required for
Hammer drill	Masonry drill, ø 8 mm	Drill holes
Hammer		Hammer in the steel tie bar.
Hex key	SW4	To open the enclosure cover
	SW8	To open the cover of the measuring unit Screw plugs of gas sensors
Open-end wrench	SW24	Screw plugs of gas sensors
	SW27	Cable gland and mounting of gas sensors
	SW13	Fastening nuts of steel tie bars
	SW10	Grounding bolts
Flat-blade screwdriver	Max. 3 mm	Cable installation
Ferrule pliers		For onsite cables



Observe the country-specific tunnel regulations for mounting material. Suitable ferrules are made available as standard. These are not required for cables from Endress+Hauser.

3.3 Preparing the installation location

- ▶ Secure the place of work
- ▶ Provide sufficient light, power and, when necessary, a lifting platform at the place of work.

Keep fixing material available as well as suitable drills, lines, socket wrench set, marking material, measurement tools.



- ▶ **Determine the angle of inclination:** see [“Maximum allowable angle of inclination and installation location height”](#), page 23 and see [“Maximum allowable angle of rotation of fitted VISIC100SF”](#), page 23.

3.4 Mounting

3.4.1 Scope of delivery

- ▶ Check the scope of delivery against the order and delivery documents.

3.4.2 Mounting the VISIC100SF

- 1 Determine the sensor installation location according to the project planning.

Fig. 13: Maximum allowable angle of inclination and installation location height

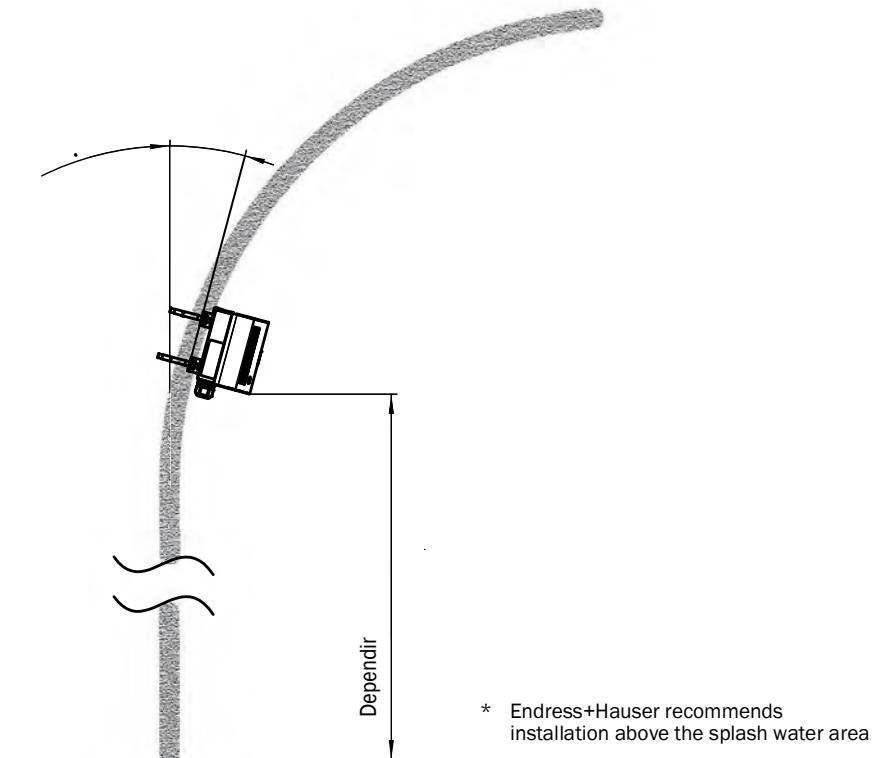
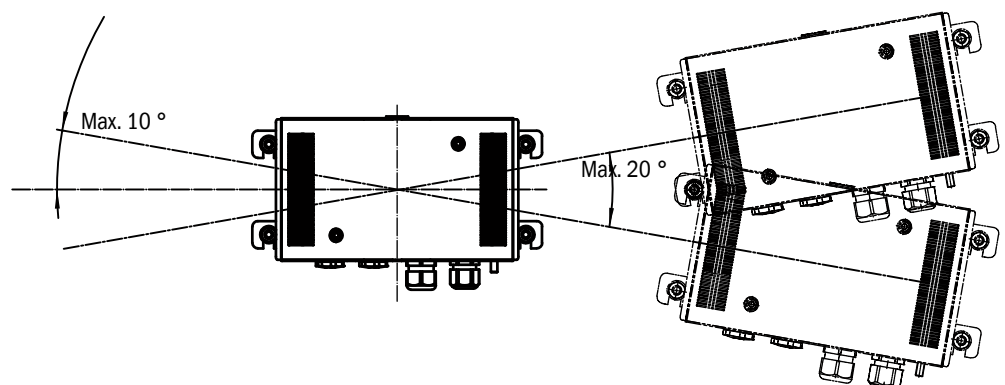

Fig. 14: Maximum allowable angle of rotation of fitted VISIC100SF



Use a wall plate when the installation walls are extremely uneven. Consider this special solution during project planning.

- 2 Drill holes for the VISIC100SF wall bracket as shown in the VISIC100SF drilling plan, see [“VISIC100SF drilling plan \(all units of measurement in mm\)”](#), page 100.
- 3 Hammer in the M8 steel tie bar (from mounting kit).
- 4 Mount the rear enclosure panel.

Fig. 15: Mounting - rear enclosure panel

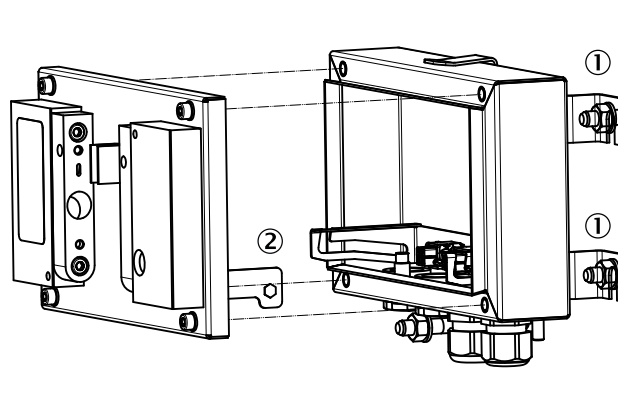

- ① Mounting bracket
- ② Hinge fixture for the measuring unit

- 5 Hinge the measuring unit in.
- 6 Wiring, see [“VISIC100SF wiring”](#), page 29.
- 7 Commissioning, see [“Commissioning”](#), page 38.
- 8 Screw the measuring unit on.
- 9 Mount the enclosure cover.

Information for loosening the enclosure cover:



After loosening the two screws, removing the enclosure cover could be somewhat sluggish. Therefore, the enclosure cover side panels are extended on the sides and serve as handles.



If the enclosure cover was placed on the measuring unit while the VISIC100SF was open, it can be easily removed by pressing the loosened screws against the measuring unit.



Carefully fold the measuring unit open. The cable connections can cause the hinge fixture to unhook from the hinge rail.

3.4.3 Mounting the connection unit (optional)

Two connection unit versions:

Fig. 16: Connection unit TB-A1 for reconnection of cables



- Connection unit to reconnect cables provided (e.g. rigid to flexible cable, or cross-section adaptation).

Fig. 17: Connection unit TB-A2 with 24V voltage supply unit and reconnection

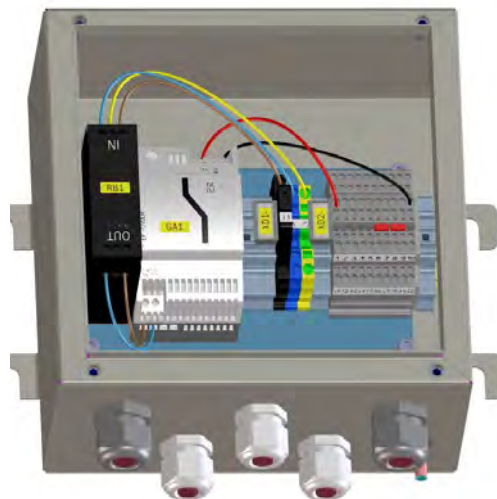

- Connection unit with power supply unit and power supply filter.
- Connection unit to reconnect cables provided.

Material required for connection unit mounting and installation

Material and drilling plan are identical to the VISIC100SF sensor, see [“Mounting material”, page 21](#) and see [“Dimensions of control unit for VISIC100SF \(all units of measurement in mm\)”, page 100](#).

Mounting the connection unit

- 1 Determine the connection unit mounting location according to the project planning.
- 2 Drill holes for the connection unit as shown in the drilling plan, see [“Dimensions of control unit for VISIC100SF \(all units of measurement in mm\)”, page 100](#).
- 3 Hammer in the M8 steel tie bar (from mounting kit).
- 4 Mount the connection unit.
- 5 Wiring, see [“Connection unit wiring”, page 35](#).
- 6 Screw the cover on.

3.4.4 Mounting the TAD control unit (optional)

- 1 Determine the TAD control unit installation location according to project planning. Dimensions of the TAD control unit, see “Control unit dimensions (all units of measurement in mm)”, page 99.

+i With a separate power supply, the TAD control unit can be installed at a distance of max. 1200 m to the installation location of the VISIC100SF.

- 2 Drill holes for the TAD control unit as shown in the drilling plan, see “Drilling plan for TAD control unit for VISIC100SF (all units of measurement in mm)”, page 102.
- 3 Hammer in the M8 steel tie bar (from mounting kit).
- 4 Mount the TAD control unit.
- 5 Wiring, see “TAD control unit wiring”, page 36.

3.4.5 Mounting and commissioning of the gas sensors (optional)



WARNING: Hazard through low voltage

- ▶ Disconnect the 24 V plug connection in VISIC100SF before commissioning or exchanging the gas sensors.



NOTICE: Gas sensor damage by certain substances and gases

Certain substances and gases in the atmosphere to be monitored can impair the sensitivity of the electrochemical cell or destroy it completely. The following are known:

- Polymerizing substances, such as ethylene oxide, acrylonitrile, butadiene, styrene, silicones and silicone vapors
- Corrosive substances, such as halogenated hydrocarbons
- Catalyst poisons, such as sulfur and phosphorus compounds, silicon compounds, metal vapors
- Organic solvents
- Oils and lubricants

Material required	Characteristics	Required for
CO, NO, NO ₂ sensors	Compact measuring sensor with connection cable, calibrated and temperature corrected	For measuring CO, NO or NO ₂ (optional)
Hex key SW 8 or open-end wrench SW24		Removing the screw plugs
Open-end wrench SW27		Mounting of gas sensors



NOTE: Observe sensor service life!

The date of manufacture is marked on the labels of the CO, NO and NO₂ sensors. Specified service life^[1]:

- Maximum storage duration: 6 months as from date of manufacture (in unopened original packaging).
- Maximum service life as from initial commissioning: 1 year, replacement or recalibration.
- ▶ Order spare sensors close to commissioning.
- ▶ Observe the storage conditions of the sensors, see “Technical Data”, page 103.

[1] This information refers to compliance with the specified properties after factory calibration. A check and/or exchange is necessary after a longer storage and service life.

- 1 Check the date of manufacture with respect to maximum storage duration. Recommended maximum storage duration: Six months. Date of manufacture: See serial number.
 - Digits 1 and 2: Year of production
 - Digits 3 and 4: Week of production

- 2 Use the SW 8 hex key or the SW24 open-end wrench to remove the black screw plug on the underside of the enclosure.

Fig. 18: Gas sensor screw plugs

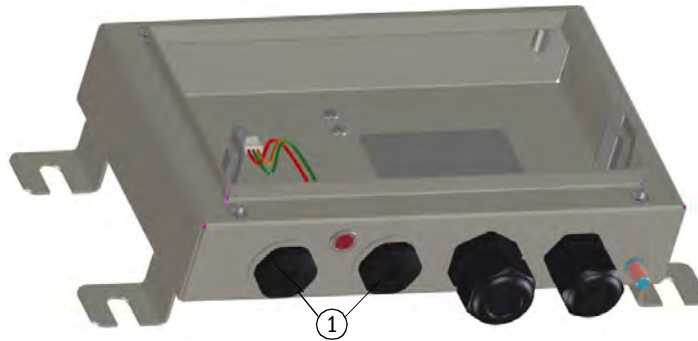

- ① Screw plugs



NOTICE:

When mounting two gas sensors, start with the left sensor.

- 3 Position the gas sensor in a free thread and screw in by hand to the stop.
- 4 Tighten the gas sensor from the inside with an open-end wrench SW27 by 1/4 turn.
- 5 Plug the connecting cable into one of the two connection terminal strips on the circuit board (see Fig. 19: page 28, marking 3).
- 6 Close the device:
 - ▶ Tip the measuring unit up and fasten it with the 4 screws.
 - ▶ Position the enclosure cover on the front side of the device.
 - ▶ Screw the two screws on the enclosure cover tight with the SW4 hex key.



The gas sensor requires a heating up phase of maximum 5 minutes. The Status LED remains red until the heating up phase has finished.



Do not screw the screw plugs in again after fitting the gas sensors. Otherwise, no sample gas can reach the electrochemical cells.

Fig. 19: Mounting of NO or CO, NO₂ gas sensor (optional)

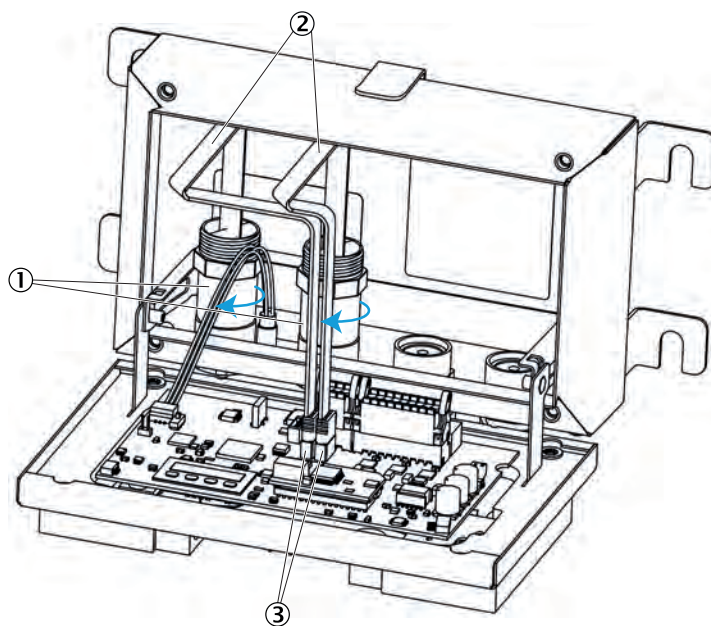

- ① Gas sensors
- ② Connecting cables of gas sensors
- ③ Connection socket for connecting cables of gas sensors

3.4.5.1 Cross-sensitivity Table for gas sensors

Table 4: Gas concentration of interfering gas and reaction of gas sensor

Target gas	Interfering gas				
	CO (180 ppm)	NO (60 ppm)	CO ₂ (5000 ppm)	NO ₂ (18 ppm)	Hexane (100 ppm)
CO	100%	< 10%	0%	0%	0%
NO	0%	100%	0%	< 2%	0%
NO ₂	0%	< 10%	0%	(100%)	0%

3.5 VISIC100SF wiring

3.5.1 Safety notes

**WARNING: Hazard by voltage.**

- ▶ Only allow an authorized electrician to work on the electric system.
- ▶ Observe the relevant safety regulations during all installation work.
- ▶ Take suitable protective measures against local risks and those arising from the plant.

**NOTE: Onsite electrical installation is the responsibility of the operator.**

Provide separate external main power switches which disconnect all connectors, and fuses in the proximity of the VISIC100SF (max. power input of the VISIC100SF → Technical data)

**NOTE: Device damage through electrostatic discharges**

The VISIC100SF may be connected only by an expert.
▶ Observe the applicable ESD Guidelines.

**NOTE: Avoid damage to the electronics**

Before signal connections are established (also with plug connections):

- ▶ Separate the VISIC100SF, the connection unit and/or TAD control unit from the main voltage supply.



The connection unit and/or the TAD control unit do not have independent main power switches. In accordance with EN 61010, the following must be ensured before installation:

- A main power switch is available in the tunnel.
- Service personnel can easily access the main power switch.
- The main power switch is marked as disconnecting device.

3.5.2 Connecting the LED

Fig. 20: Slot for Status LED cable

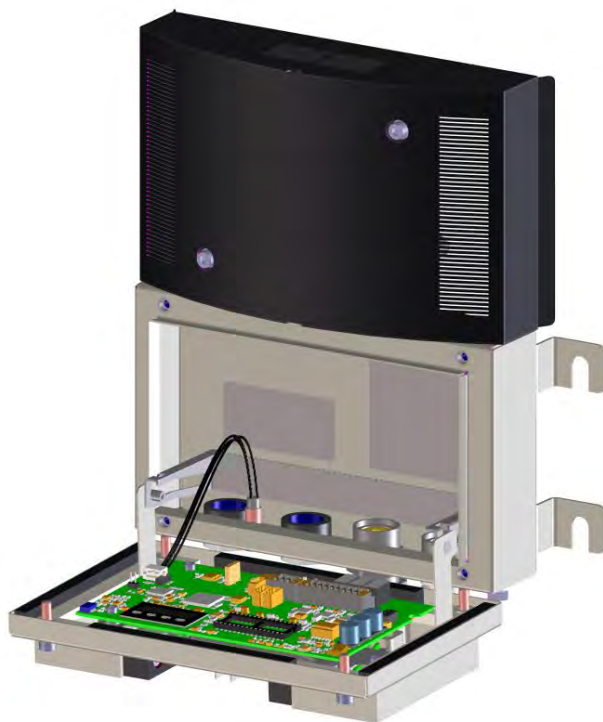

Fig. 21: LED switch position on the circuit board

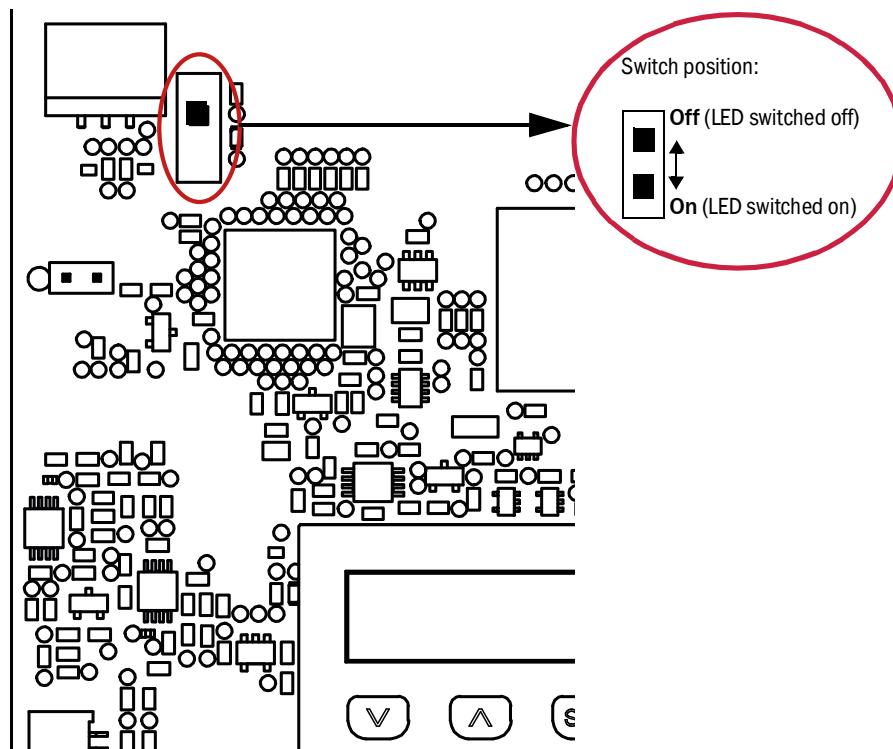

Fig. 22: Grounding connection on VISIC100SF



① Connection to fasten the functional grounding

3.5.3 Wiring of analog outputs, relay outputs and voltage supply

Fig. 23: Wiring plan for analog signals, relay outputs and voltage supply for VISIC100SF

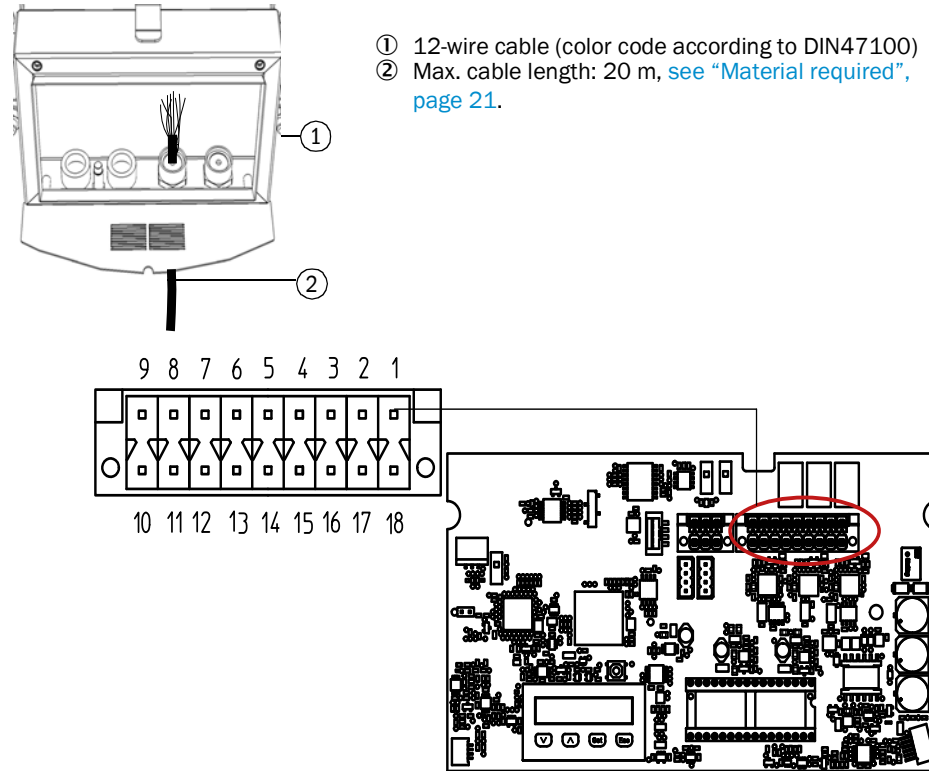

- ① 12-wire cable (color code according to DIN47100)
- ② Max. cable length: 20 m, see “Material required”, page 21.

Terminal	Designation	Usage
Voltage supply		
1		+24 VDC
18	GND	Ground (GND)
Digital outputs		
2	DO1 - COM	Maintenance Request Common
17	DO1 - NO	Maintenance request Normally Open
3	DO2 - COM	Malfunction Common
16	DO2 - NC	Malfunction Normally Closed
Analog outputs		
5	+ AO1	+ visibility
14	- AO1	- visibility
6	+ AO2	+ gas concentration (standard NO)
13	- AO2	- gas concentration (standard NO)
7	+ AO3	+ gas concentration (standard CO)
12	- AO3	- gas concentration (standard CO)
Analog inputs		
9	PT1000-A	+temperature input
10	PT1000-B	- temperature input

+i Observe the assignment of analog outputs for output of NO₂ or temperature values, see “Assigning analog outputs with menu item “IOMap””, page 63.

3.5.4 Bus interface wiring

Fig. 24: Wiring plan for RS-485 interface

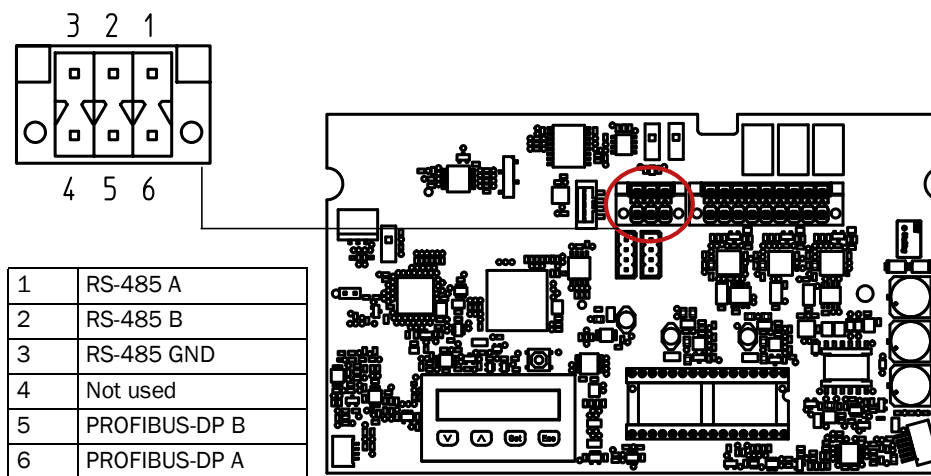

+i The RS-485 interface can be used for Modbus® or TAD control unit (optional).

3.5.5 Shielding

The shield must be grounded at both ends to ensure effective shielding against high-frequency interference. Especially on installations located away from each other, potential differences can occur and therefore lead to potential equalization currents along a cable shield. Such equalization currents on a cable shield must be avoided at all costs because these can lead to interference signals. Contacting of the shield with the brushes of the cable gland, “Shielding in VISIC100SF”, page 33.

Fig. 25: Shielding in VISIC100SF

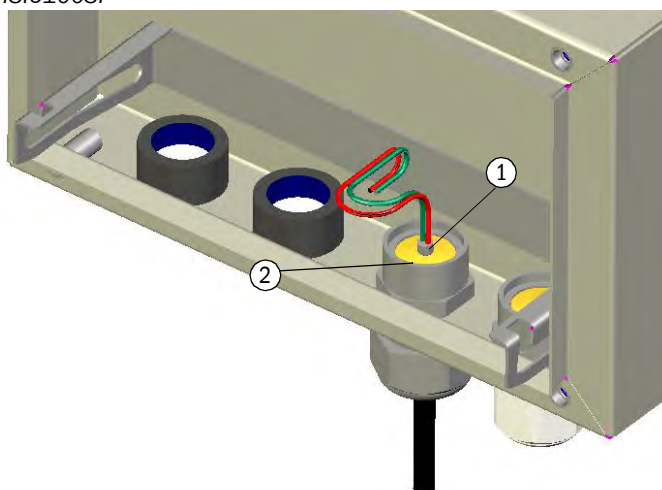

- ① Line shield
- ② Cable gland with brushes

To prevent potential differences between individual system components, all devices on the bus must have the same potential. To achieve this, all devices must be connected to each other with a potential equalization conductor (see “Potential equalization cable.”, page 34).



CAUTION: Never use the cable shield as potential equalization

The cable shield only serves to shield against high-frequency interference and may not be used as potential equalization.

Fig. 26: Potential equalization cable.

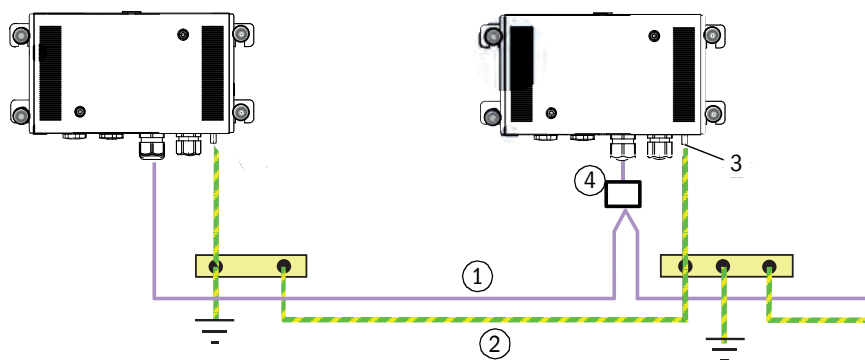

- ① Signal cable
- ② Potential equalization cable.
- ③ Connection for grounding conductor
- ④ T-connector or connection unit terminal

3.5.6 Connection unit wiring

Table 5: Voltage supply of connection unit

PE	
N	85 ... 264 V AC
L	45 ... 65 Hz

Table 6: Connection uni wiring tablet

Terminal	Id.	VISIC100SF analog	VISIC100SF system bus
1		+24 V DC	+24 V DC
2		+24 V DC	+24 V DC
3		Ground (GND)	Ground (GND)
4		Ground (GND)	Ground (GND)
5	DO1 - COM	Maintenance Request Common	RS-485 A ^[1]
6	DO1 - NO	Maintenance request Normally Open	RS-485 A ^[1]
7	DO2 -COM	Malfunction Common	RS-485 B ^[1]
8	DO2 - NC	Malfunction Normally Closed	RS-485 B ^[1]
9	DO3 - COM	Not used	RS-485 GND ^[1]
10	DO3 - NO	Not used	RS-485 GND ^[1]
11	+ A01	+ visibility	PROFIBUS-DP A ^[2]
12	- A01	- visibility	PROFIBUS-DP A ^[2]
13	+ A02	+ gas concentration (CO, NO or NO ₂)	PROFIBUS-DP B ^[2]
14	- A02	- gas concentration (CO, NO or NO ₂)	PROFIBUS-DP B ^[2]
15	+ A03	+ gas concentration (CO, NO or NO ₂)	
16	- A03	- gas concentration (CO, NO or NO ₂)	
17, 18, 19, 20		Not used	Not used

[1] When connected via RS-485, connection terminals 5 + 6, 7 + 8 and 9 + 10 must be connected with a jumper.
 [2] When connected via PROFIBUS, connection terminals 11 + 12 and 13 + 14 must be connected with a jumper.



Observe the configuration of the analog outputs when using gas sensors, see [“Assigning analog outputs with menu item “IOMap””, page 63.](#)

3.5.7 TAD control unit wiring

Table 7: TAD control unit voltage supply

PE	
N	88 ... 264 V AC
L	47 ... 63 Hz

Table 8: TAD control unit Wiring Table

Terminal	Id.	TAD control unit without I/O modules	Id.	TAD control unit with I/O modules [1]
1		+ 24 V DC		
2		+ 24 V DC		
3		+ 24 V DC		
4			DI-IN	
5		Ground (GND)		
6		Ground (GND)		
7		Ground (GND)		
8			DI-DGND	
9		RS-485-A		
10		RS-485-A		
11				
12		RS-485 B		
13		RS-485 B		
14		RS-485 GND		
15	- AO1	- visibility	+ AO1	
16	- AO2	- gas concentration (standard NO)	+ AO2	
17	- AO3	- gas concentration (standard CO)	+ AO3	
18	-		+ AO4	
19	+ AO1	+ visibility	AO-AGND	
20	+ AO2	+ gas concentration (standard NO)	AO-AGND	
21	+ AO3	+ gas concentration (standard CO)	AO-AGND	
22	-		AO-AGND	
23	DO1 - NO	Maintenance request Normally Open	DO1	
24	DO1 - COM	Maintenance Request Common	DO2	
25	DO2 - NC	Malfunction Normally Closed	DO3	
26	DO2 -COM	Malfunction Common		
27			DO-DGND	
28			DO-DGND	
29			DO-DGND	
30				

[1] On request



The AO is set to 1 mA when the communication between VISIC100SF and TAD control unit is aborted. The DO module remains unchanged in the last valid state until new data are transferred.



Observe the configuration of the analog outputs when using gas sensors, see [“Activating/deactivating the heating \(optional\)”](#), page 66.

3.6 Connections

3.6.1 Standard version

Fig. 27: VISIC100SF connections

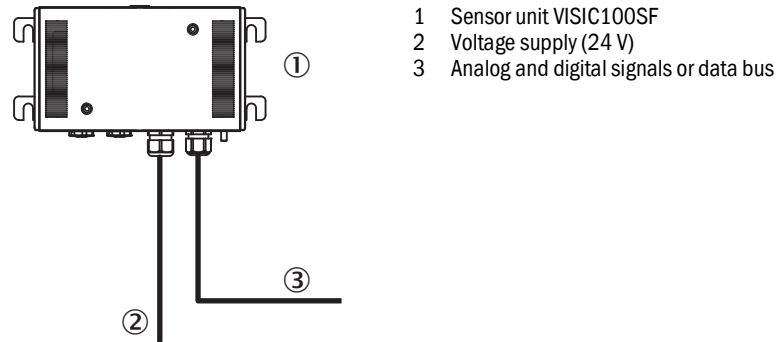

3.6.2 VISIC100SF with connection unit

Fig. 28: VISIC100SF connections with connection unit

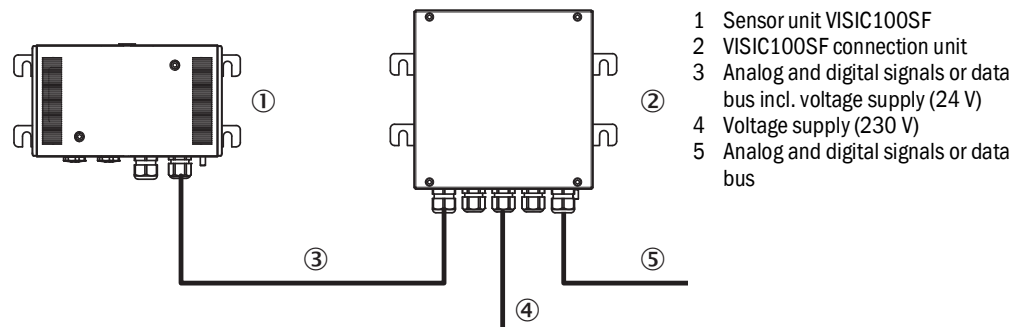

3.6.3 VISIC100SF connections with TAD control unit

Fig. 29: VISIC100SF connections with TAD control unit

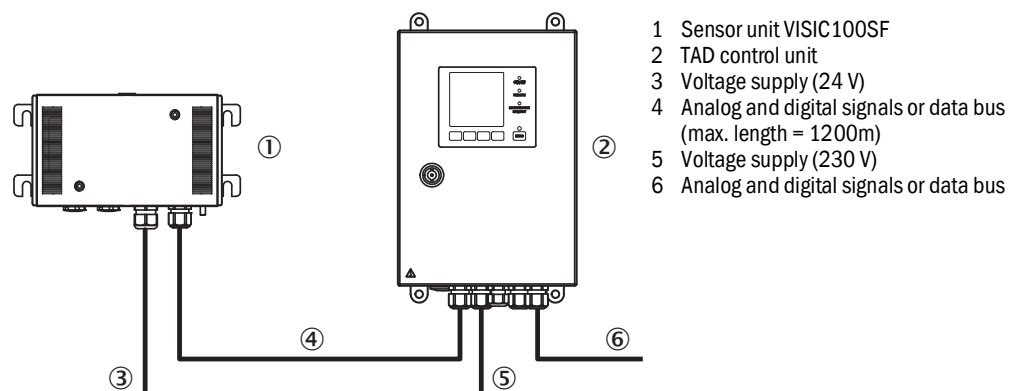

4 Commissioning

Overview of commissioning tasks

- Check wiring of VISIC100SF components.
- Check and switch on voltage supply.
- Check Status LED.
- Check measured value plausibility.
- Assign analog outputs, see [“Assigning analog outputs with menu item “IOMap””, page 63](#).
- Hardware test.



Tools required for commissioning, see [“Tools”, page 22](#)

4.1 Commissioning, step by step

1. Disconnect voltage supply.
2. Check for correct installation before commissioning.
3. Using the SW4 hex key to open the enclosure cover, take the cover off and place it on the fixture provided.
4. Loosen the four screws of the measuring unit with the SW4 hex key and swivel the measuring unit down.
5. Check wiring.
 - » For VISIC50SF: see [“Wiring of analog outputs, relay outputs and voltage supply”, page 32](#).
 - » Connection unit, see [“Connection unit wiring”, page 35](#).
 - » TAD control unit, see [“TAD control unit wiring”, page 36](#).
6. Connect Status LED cable to circuit board slot.
7. Connect gas sensors to circuit board slots, see [“Connection unit wiring”, page 35](#).
8. Contact plug for voltage supply.
9. Switch the voltage supply on.
10. Plausibility check on measured values and device status.
 - ▶ If the measured values shown on the display are implausible, check enclosure for coarse contamination and clean as necessary.
11. Perform hardware test:
 - ▶ Set the device to Maintenance mode (“Maint”) using the keypad. For further information, refer to Section “Menu” see [“Calling up maintenance request and malfunction messages with menu item “Status””, page 53](#).
 - ▶ Set the current levels of analog outputs and digital outputs (maintenance request/ malfunction). For further information, refer to Section “Menu” see [“Testing the analog output for the K-value with submenu item “AO1””, page 60](#) and see [“Testing the “Maintenance request” relay with submenu item “MRq””, page 62](#).
12. Deactivate Maintenance mode. Refer to Section “Menu”, see [“Activating maintenance in menu item “Maint””, page 53](#) for further information.

13. Close the device:
 - ▶ Tip measuring unit up.
 - ▶ Screw the four screws with the SW4 hex key.
 - ▶ Position the enclosure cover on the front side of the device.
 - ▶ Screw the two screws on the enclosure cover tight with the SW4 hex key.
14. Visual check: Status LED should be green. The following reasons can cause the Status LED not to be green:
 - LED switch on circuit board switched off. (Factory setting: LED switch is set to "On") Switch Figure, see ["LED switch position on the circuit board", page 30](#).
 - Enclosure cover not fitted (Status LED red).
 - Gas sensors in heating up phase (Status LED red for max. 30 minutes).
 - Check the plug on the circuit board when the Status LED is not on.
 - Active maintenance and malfunction states. To retrieve the maintenance request and malfunction messages, see ["Testing the analog output for the K-value with submenu item "A01"', page 60](#). Malfunction and maintenance request Code Tables, see ["Device error coding", page 95](#) and see ["Description of maintenance requests", page 96](#).

4.2 Bus connections

There is the option to output the VIS, CO and NO or NO₂ value digitally via Modbus® RTU (standard) or PROFIBUS DP-V0 (optional). Bus connections require low wiring effort.

4.3 Modbus® RTU (integrated in the VISIC100SF standard version)

The Modbus® RTU interface allows the user to read out the VISIC100SF measured values and status information using the two function codes “Read Holding Register (0x03)” and “Read Coil (0x01)”.

+i The protocol (Modbus® RTU control unit TAD) can be set on the RS-485 interface using the device display. See Section “Menu”, see “Setting the RS-485 interface with submenu item “Bus””, page 56.

Modbus® RTU interface parameterization options

The Modbus® RTU interface can only be parameterized using the device display. The following parameters can be changed here:

- Modbus® RTU ID (0 to 247), see Section “Menu”, see “Setting bus parameters”, page 57.
- Parity, see Section “Menu”, see “Setting the Modbus® data transfer format with menu item “MB Par”.”, page 58.
- Baud rate, see Section “Menu”, see “Setting the Modbus® baud rate with menu item “MB BdR””, page 59.

+i The VISIC100SF must be restarted to save parameter changes. Press “Reset” to restart, see “Measuring unit - circuit board with display and keypad”, page 18.

4.3.1 Modbus® RTU data format

Parity	<ul style="list-style-type: none"> • Even parity, 1 stop bit • Odd parity, 1 stop bit • No parity, 1 stop bit • No parity, 2 stop bits
--------	----------------------------------------------------------------------------------------------------------------------------------------------------------------------------------

4.3.2 Modbus® RTU baud rates

- 4.8 k
- 9.6 k
- 19.2 k
- 38.4 k
- 57.6 k

4.3.3 Read Holding Register (0x03)

The Modbus® RTU interface register structure comprises all measured values and associated measured value status. The coding of the measured value status behaves synchronous to the measured value status of the PROFIBUS interface, see [“Coding of measured value status of visibility”, page 44.](#)

Table 9: Read Holding Register Modbus® RTU

Register	Designation	Significance
100	K-value, 4 byte floating point, ABCD	
102	K-value status, 1 byte unsigned integer	
103	Dust concentration, 4 byte floating point, ABCD	
105	Dust concentration status, 1 byte unsigned integer	
106	Uptime [h], 2 byte unsigned integer	Uptime: Operating hours since last reset
107	OpHours [d], 2 byte unsigned integer	OpHours: Total operating time in days
108	CO value, 4 byte floating point, ABCD	
110	CO value status, 1 byte unsigned integer	
111	CO-NextMrq [d], 2 byte unsigned integer	CO-NextMrq: Operating days until next maintenance request of CO cell
112	CO-OpHours [d], 2 byte unsigned integer	CO-OpHours: Operating duration of CO cell in days
113	NO value, 4 byte floating point, ABCD	
115	NO value status, 1 byte unsigned integer	
116	NO-NextMrq [d], 2 byte unsigned integer	NO-NextMrq: Operating days until next maintenance request of NO cell
117	NO-OpHours [d], 2 byte unsigned integer	NO-OpHours: Operating duration of NO cell in days
118	NO ₂ value, 4 byte floating point, ABCD	
120	NO ₂ value, status, 1 byte unsigned integer	
121	NO ₂ value, NextMrq [d], 2 byte unsigned integer	NO ₂ NextMrq: Operating days until next maintenance request of NO ₂ cell
122	NO ₂ value OpHours [d], 2 byte unsigned integer	NO ₂ OpHours: Operating duration of NO cell in days
123	Contamination, 2 byte unsigned integer	Contamination: Contamination of sensor in percent
124	Temperature value, 4 byte floating point, ABCD	External PT1000, optional
126	Temperature value status, 1 byte unsigned integer	External PT1000, optional
127	Maintenance request, 2 byte unsigned integer	
128	Device fault, 2 byte unsigned integer	

Register 123 contains information on the actual degree of contamination of the optics for visibility measurement.

Coding of registers 127 & 128 (maintenance request/device fault), see Table, see [“Device error coding”, page 95](#) and see [“Description of maintenance requests”, page 96.](#)

Example:

Read 4 byte float from server (ID 101) with start address 100:

TX-> <65 03 00 64 00 02 8D F0>

RX-> <65 03 04 3F 48 2B 67 0C ED>

Current K-value = 0x3F482B67 ≈ 0.78

4.3.4 Modbus® RTU Read Coil (0x01)

Function code “Read Coil (0x01)” serves to read out all malfunction and maintenance request messages from VISIC100SF.

Table 10: Read Coil Modbus® RTU

Coil number	Designation
200	Contaminated optics
201	Limit of CO operating hours reached
202	Limit of NO operating hours reached
203	Maintenance request of external temperature sensor
204-206	Reserved
207	Limit of NO ₂ operating hours reached
208-215	Reserved
216	Error Vis
217	Error CO sensor
218	Error NO sensor
219	Error EEPROM
220	Error heating
221	Error 4 ... 20 mA interface
222	Error FPGA
223	Error CPU
224	Error program flow
225	Error enclosure cover
226	Error NO ₂ cell
226-229	Reserved
230	Maintenance active
231	Reserved

Example:

Read coil number 200 from server (ID 101):

TX-> <65 01 00 C8 00 01 74 10>

RX-> <65 01 01 00 4E B8>

Maintenance request Vis = false

4.4 PROFIBUS DP-V0 (optional)

The PROFIBUS module belongs to the VISIC100SF when configured at the same time during ordering. The VISIC100SF is integrated in the bus via a restart after wiring.

4.4.1 PROFIBUS addressing

The PROFIBUS-DP address of the device can be managed via the keypad.

For further information, see Section “Menu”, see [“Setting the PROFIBUS address in “PB ID””, page 57.](#)



The device must be restarted after the address is changed.

Press “Reset” to restart, see [“Measuring unit - circuit board with display and keypad”, page 18.](#)

4.4.2 PROFIBUS DP-V0 baud rates

The PROFIBUS module has an autobaud function that automatically detects the following baud rates:

- 9.6 k
- 19.2 k
- 45.45 k
- 93.75 k
- 187.5 k
- 500 k
- 1.5 M

4.4.3 Access via GSD file

The GSD file provided allows access to the following modules on the PROFIBUS master:

Table 11: GSD file modules

Module (coding)	Significance
KValue (Real), Status (UInt8)	Visibility measured value
DustValue (Real), Status (UInt8)	Dust concentration
Uptime VISIC100SF [h] (UInt16)	Operating duration of VISIC100SF since last reset in hours
OpHours VISIC100SF [d] (UInt16)	Total operating duration of VISIC100SF in days
CoValue (Real), Status (UInt8)	CO gas concentration in ppm
NxtMrq CO-Cell [d] (UInt16)	Operating days until next maintenance request of CO cell
OpHours CO-Cell [d] (UInt16)	Operating duration of CO cell in days
NoValue (Real), Status (UInt8)	NO gas concentration in ppm
NxtMrq NO-Cell [d] (UInt16)	Operating days until next maintenance request of NO cell
OpHours NO-Cell [d] (UInt16)	Operating duration of NO cell in days
NO ₂ Value (Real), Status (UInt8)	NO ₂ gas concentration in ppm
NxtMrq NO ₂ -Cell [d] (UInt16)	Operating days until next maintenance request of NO ₂ cell
OpHours NO ₂ -Cell [d] (UInt16)	Operating duration of NO ₂ cell in days
Contamination (UInt16)	Contamination of sensor in percent
Temperature (Real), Status (UInt8)	Temperature of external PT1000 in °C
MainReq (UInt16)	Maintenance request, coded bit-by-bit, compare “Description of maintenance requests”, page 96
DeviceFault (UInt16)	Error status byte, compare “Device error coding”, page 95
Counter (UInt16)	Measured value meter
CRC16-CCITT (UInt16)	Checksum according to CRC16-CCITT



The GSD file is delivered on a data medium when the PROFIBUS module is ordered.

4.4.4 Coding of visibility measured value status

Every VISIC100SF measured value has a measured value status. The following Tables show the measured value status coding and significance.

Table 12: Coding of measured value status of visibility

Priority	Status K-value, dust	Status byte PROFIBUS/Modbus®	Status byte designation	Maintenance request	Device fault	Analog output
1	No error active	0x80	Good - OK	Inactive	Inactive	Value
2	Measured value dynamic below limit value	0xA4	Good - maintenance required	Active	Inactive	Value
3	Contamination 1 st level	0xA4	Good - maintenance required	Active	Inactive	Value
4	Measuring range overflow	0x7A	Uncertain - high limit	Inactive	Inactive	23 mA 20 mA ^[1]
5	Contamination 2 nd level	0x68	Uncertain - maintenance demanded	Active	Active	1 mA
6	Error µC	0x79	Bad - maintenance alarm	Inactive	Active	1 mA
7	Threshold LED	0x24	Bad - maintenance alarm	Inactive	Active	1 mA
8	Error FPGA	0x24	Bad - maintenance alarm	Inactive	Active	1 mA

[1] When the TAD control unit is used with I/O modules

Table 13: Coding of measured value status of temperature sensor

Priority	Status temperature sensor	Status byte PROFIBUS/Modbus®	Status byte designation	Maintenance request	Device fault	Analog output
1	No error active	0x80	Good - OK	Inactive	Inactive	Value
2	Measuring range underflow	0x79	Uncertain - low limit	Active	Inactive	1 mA
3	Sensor error	0x24	Bad - maintenance alarm	Active	Inactive	1 mA
4	Error µC	0x24	Bad - maintenance alarm	Active	Inactive	1 mA
-	Sensor not activated	0x23	Bad - passivated	Inactive	Inactive	1 mA

Table 14: Coding of measured value status of gas cells

Priority	Status gas cell	Status byte PROFIBUS/Modbus®	Status byte designation	Maintenance request	Device fault	Analog output
1	No error active	0x80	Good - OK	Inactive	Inactive	Value
2	Sensor test running	0xBC	Good - internal function check	Inactive	Inactive	Value
3	Operating hours 1 st level	0xA4	Good - maintenance required	Active	Inactive	Value
4	Operating hours 2 nd level	0x68	Uncertain - maintenance demanded	Active	Active	1 mA
5	Measuring range overflow	0x7A	Uncertain - high limit	Inactive	Active	23 mA 20 mA ^[1]
5	Measuring range underflow	0x79	Uncertain - low limit	Inactive	Active	1 mA
6	Start / heating up time	0x3C	Bad - function check	Inactive	Active	1 mA
7	Hardware error / cell	0x24	Bad - maintenance alarm	Inactive	Active	1 mA
8	Error µC	0x24	Bad - maintenance alarm	Inactive	Active	1 mA
-	No cell present	0x23	Bad - passivated	Inactive	Inactive	1 mA

[1] When the TAD control unit is used with I/O modules

4.5 RS-485 - topology and bus termination

When using the RS-485 interface, all field devices are typically connected to one bus structure (line) (see “Bus topology”, page 45). Each segment can have up to 32 nodes (client and servers). The start and end of each segment must be terminated with a bus termination. A switch on the circuit board serves to set the bus termination on a VISIC100SF, see “Bus termination on the circuit board”, page 45.

Fig. 30: Bus topology

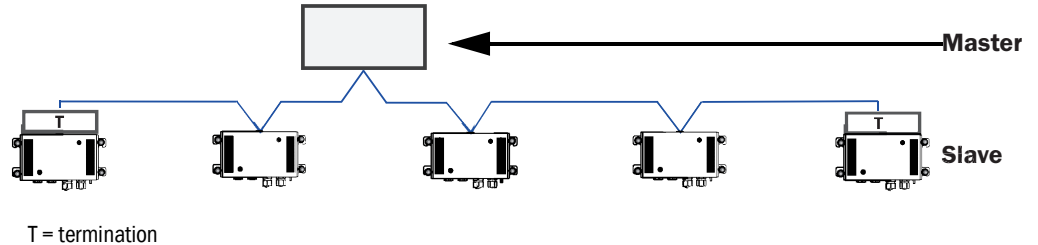
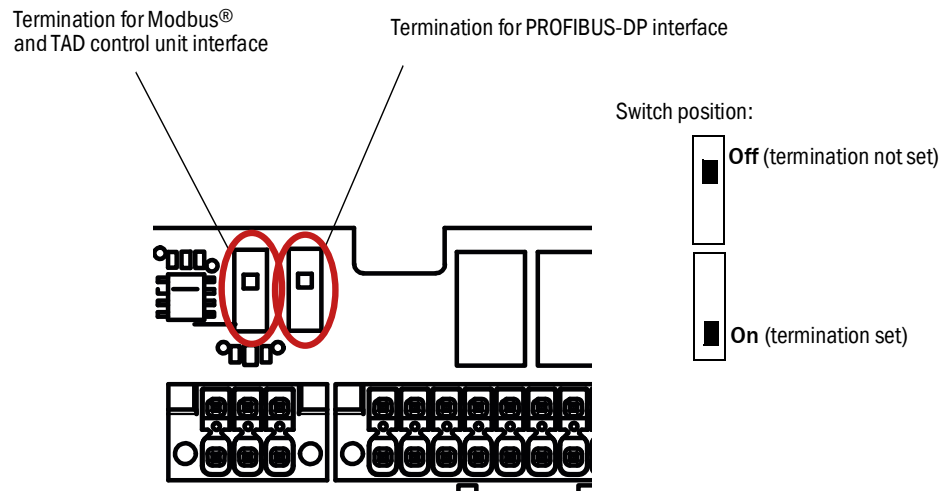

Fig. 31: Bus termination on the circuit board



4.6 Stub line length for terminal box on all RS-485 bus systems

According to the PROFIBUS specification, a maximum total of all stub lines of 6.60 m is allowed per DP segment. Longer stub lines are allowed for lower data transmission rates.

Table 15: Maximum stub line lengths

Bit rate	Total capacitance allowed	Sum of stub line lengths
1.5 Mbit/s	0.2 nF	6.6 m
500 kbit/s	0.6 nF	20 m
187.5 kbit/s	1.0 nF	33 m
93.75 kbit/s	3.0 nF	100 m
19.2 kbit/s	15 nF	500 m

If there are more than 32 nodes or the network span is being extended, power amplifiers (repeaters) allow linking the networks.

Cable properties for using the RS-485 interface

Endress+Hauser recommends using shielded cable type A with following properties:

Table 16: Cable properties for the RS-485 interface

Surge impedance R_w	135...165	Ohm
Capacitance per unit length C'	< 30	pF/m
Loop resistance R'	110	Ohm/km
Wire diameter d	0,64	mm
Wire cross-section q	> 0.34	mm ²



Shielded cable type A is a twisted two-wire cable.

5 Operation

5.1 Operating and display elements

5.1.1 Display with keypad in VISIC100SF

VISIC100SF display and keypad



- ① Current operating mode
- ② Measured component displayed
- ③ Measured value of component displayed
- ④ Arrow button to scroll down in the menu
- ⑤ Arrow button to scroll up in the menu
- ⑥ Set button to activate functions
- ⑦ Escape button to exit a menu item



The display lighting goes on when a button is pressed. The lighting goes off 10 minutes after the last button was pressed.

Menu items

- Measuring screen, see “Displaying measured values”, page 48.
 - Visibility
 - CO
 - NO
 - NO₂
 - Contamination
 - Temperature (optional)
- Status information
- Software version
- Operating time display
- Device address assignment
- Inputs/outputs test
- Assignment of analog inputs and outputs
- Activate/deactivate temperature sensor
- Activate/deactivate heating



More information on menu navigation can be found in Section “Menu”, see “VISIC100SF menu navigation”, page 49.

5.1.2 Reset button and “Maint” LED

The Reset button restarts the VISIC100SF.

Fig. 32: Position of Reset button and “Maint” LED on circuit board

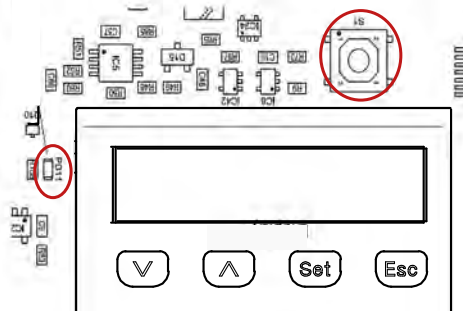

- ① Maintenance LED
- ② Reset button

5.1.3 Display unit in the TAD control unit

see “Operating and display elements (with menu example)”, page 68.

5.2 Operating states

5.2.1 Checking the operating state (visual control)

Status LED

The Status LED on the underside of the enclosure shows the operating state. (Position of the Status LED, see [“VISIC100SF sensor”](#), page 12.).

Table 17: LED display of the operating state

Operating state	Relay state	Status LED color
Initialization	Maintenance request relay open; Malfunction relay open	Red
Operation	Maintenance request relay open; Malfunction relay closed	Green
Maintenance request	Maintenance request relay closed; Malfunction relay closed	Yellow
Malfunction	Maintenance request relay open/closed depending on maintenance request state; Malfunction relay open	Red

The device delivers a valid measured value in operating states operation and maintenance request.

5.2.2 Checking malfunction messages

Read out the error code, see [“Calling up maintenance request and malfunction messages with menu item “Status””](#), page 53.

5.3 Checking the analog outputs

Check analog outputs AO1-AO3 on the VISIC, see [“Testing the analog output for the K-value with submenu item “AO1””](#), page 60.

Check AO1-AO4 of the TAD control unit with I/O modules, see [“Signal test “IO test””](#), page 60.

5.3.1 Displaying measured values

The measured values are shown on the display, see [“VISIC100SF display and keypad Menu items”](#), page 47. Further information on menu navigation to display measured values can be found in Section “Menu”, see [“Measuring operation mode “RUN””](#), page 50.

5.4 Operating functions

A comprehensive description of all operating functions can be found in Section 5 “Menu”.

5.5 Status messages

see [“Checking the operating state \(visual control\)”](#), page 48.

5.5.1 Malfunction messages

see [“Device error coding”](#), page 95.

5.5.2 Maintenance request messages

see [“Description of maintenance requests”](#), page 96.

6 VISIC100SF menu navigation

6.1 Menu structure

The menu is split into 2 modes:

- 1 "RUN" = operating mode
- 2 "SET" = setting mode

6.1.1 Short description: Entering settings on the keypad

- ▶ Use the arrow buttons to scroll through the menu.
- ▶ Button "Set" serves to switch to the menu structure.
- ▶ Button "Esc" aborts a process or switches up one menu level.
- ▶ Use the *arrow buttons* to enter numeric values:
Use the arrow buttons to increase or decrease the digit by 1. Use "Set" to switch between the digits shown on the display.







Example of an input field with a blinking digit to be edited:

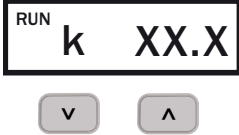

6.2 Measuring operation mode “RUN”

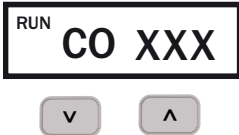
Inquire the current measured values in active measuring operation.

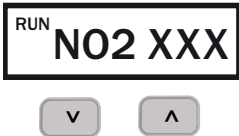
Fig. 33: “RUN” mode overview

	<p>Without TAD</p> <p>k = visibility XX.X = placeholder for measured value</p> <ul style="list-style-type: none"> • Value \geq 10: k XX.X • Value < 10: k X.XX 	<p>With TAD (with activated dust concentration)</p> <p>μg = visibility XX = placeholder for measured value</p> <ul style="list-style-type: none"> • Value \geq 0: μg XXXX
	<p>con = contamination/soiling XXX = placeholder for measured value</p> <ul style="list-style-type: none"> • Value \geq 10: conXX% • Value < 10: conX% 	
	<p>CO = CO concentration XXX = placeholder for measured value</p> <ul style="list-style-type: none"> • Value \geq 10: CO XXX • Value < 10: CO X.X 	
	<p>NO = NO concentration XXX = placeholder for measured value</p> <ul style="list-style-type: none"> • Value \geq 10: NO XXX • Value < 10: NO X.X 	
	<p>NO2 = NO₂ concentration XXX = placeholder for measured value</p> <ul style="list-style-type: none"> • Value \geq 10: NO₂ XXX • Value < 10: NO₂ X.X 	
	<p>T = temperature XXX = placeholder for measured value</p> <ul style="list-style-type: none"> • Value \geq 10: T XX • Value < 10: T X • Value < 0: T -X • Value \leq 10: T -XX 	



NOTE: When the dust concentration is activated, k becomes μ g

For representation of visibility as dust concentration, the values in the VISIC100SF display are not output as K-value but as μ g.
The transmitted measuring range in μ g is 0 to 1500 μ g.

6.3 “SET” mode

“SET” mode serves changing VISIC100SF settings.



The VISIC100SF may be operated by qualified persons only who, based on their device-specific training and knowledge of the device as well as knowledge of the relevant regulations, can assess the tasks given and recognize the hazards involved.



NOTICE: Incorrectly set parameters can lead to unsafe operation of VISIC100SF.

After a parameter change, check the newly set parameters. Ensure that the new parameters are set correctly.

Navigation in “SET” mode

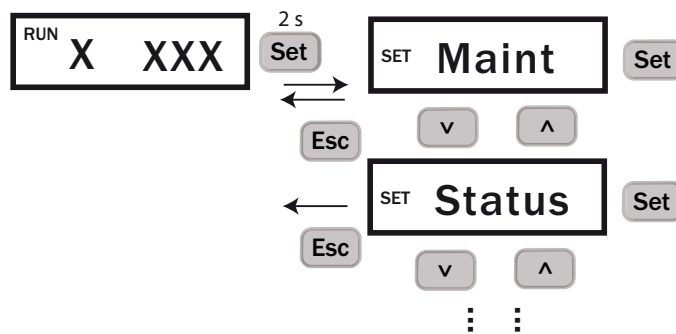

- 1 Switch from “RUN” to “SET” mode: Press “Set” for 2 seconds when in “RUN” mode for any component being displayed.
- 2 “SET” mode is now active with menu item “Maint”.
- 3 Use the arrow keys to scroll through the menu until the desired menu item is reached.
- 4 Press “Set” to access the submenu items.
- 5 Use the arrow keys to scroll through the submenu items.
- 6 Press “Set” to activate or change a submenu item.
- 7 Use “Esc” to exit the submenu or main menu items.



The device switches automatically to “RUN” mode when no user action is registered for 10 minutes. The background lighting goes off.

6.3.1 Structure and sequence of “SET” mode submenu items

1	“Maint”	Activate maintenance
2	“Status”	Current device status
3	“Uptime”	Operating times display
4	“SWVers”	Software version
5	“Bus”	Bus settings
6	“Test”	<ul style="list-style-type: none">• Check analog and digital outputs.• Confirm check of gas cells.
7	“IOMap”	Assign analog outputs
8	“AOscl”	Scale analog outputs
9	“k/μg”	Output visibility as “K-value” or dust concentration “μg”.
10	“Temp”	Activate external temperature sensor PT1000 (optional).
11	“Heat”	Activate/deactivate heating for fog dissipation (optional).
12	“Tuning”	Adjustment menu

6.3.2 Activating maintenance in menu item “Maint”

Fig. 34: Activating the setting range via menu item “Maint”

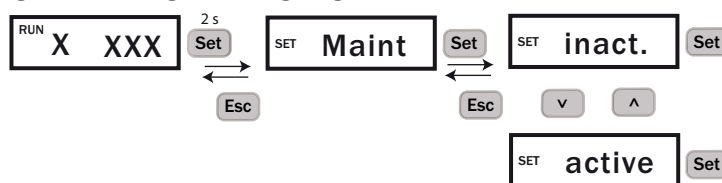

- +i** Mode “active” is reset to “inactive” after 30 minutes.
- +i** The malfunction relay is activated when mode “active” is set. The Status LED is red, the analog outputs output 1 mA and the field bus interface signals an error. The Maint LED on the circuit board is green. For further information on the Maint LED position on the circuit board, see “Position of Reset button and “Maint” LED on circuit board”, page 47.

6.3.3 Calling up maintenance request and malfunction messages with menu item “Status”

When a maintenance request or malfunction message is present, the associated maintenance request or malfunction message is output as an error code in this menu item. Scroll through with the arrow keys to display all existing error or maintenance request messages.

- +i** Abbreviations in the menu:
 MRq = Maintenance Request
 Fail = malfunction
 MrqXXX and F_XXX= code for maintenance request or malfunction. The Error Code Table can be found in Section “Maintenance”, see “Device error coding”, page 95.
 NxtMRq= Next Maintenance Request (time remaining to next maintenance request).

Fig. 35: Retrieving maintenance and malfunction messages

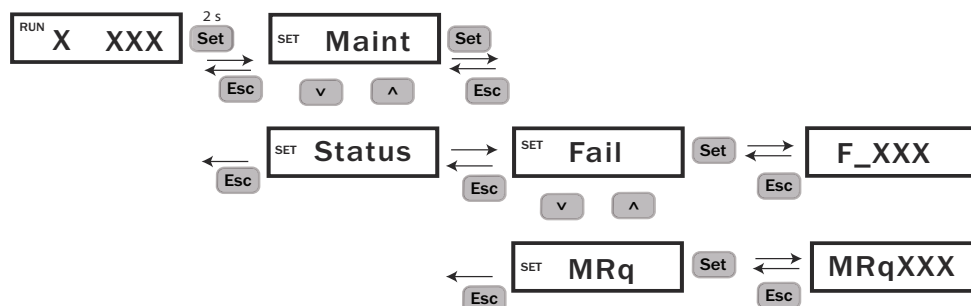

6.3.4 Maintenance request for gas sensors in submenu item “NxtMRq”

The gas sensors have an operating hours counter which displays the time remaining to the next maintenance request of the gas sensors. A maintenance request is activated after an operating time longer than 365 days. Submenu item “NxtMRq” serves to display the number of days remaining until the next maintenance request.

- +i** Abbreviations in the menu:
 NxtMRq= Next Maintenance Request (time remaining to next maintenance request).
 xxxxd = number of days

Fig. 36: Display of the remaining time (in days) to the next maintenance request

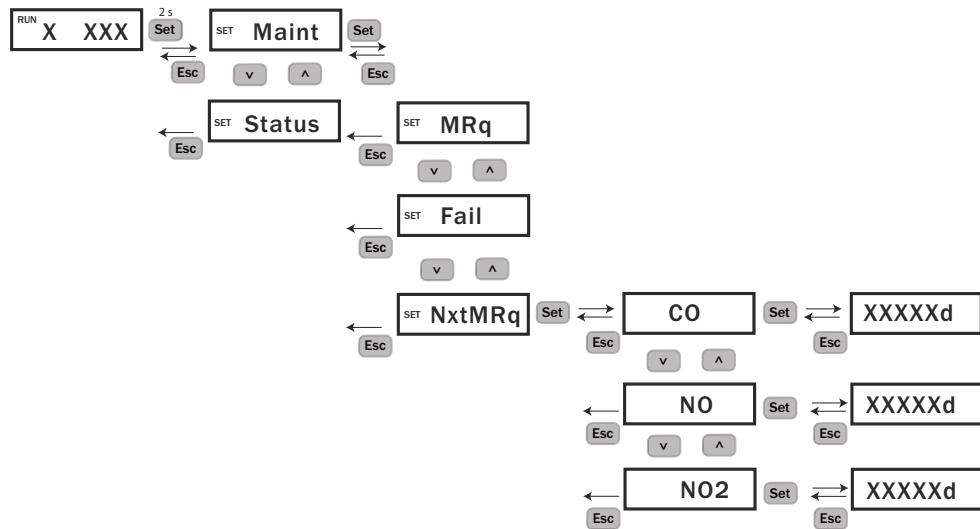

6.3.5 Calling-up the operating duration in submenu item “Uptime”

Menu item “Uptime” retrieves the following information:

- CO, NO and NO₂: Number of days (d) for the gas sensors currently in use.
- Up: Number of operating hours (h) since the last switch-on.
- Run: Operating duration since initial commissioning in days (d).

Fig. 37: Calling up the operating duration

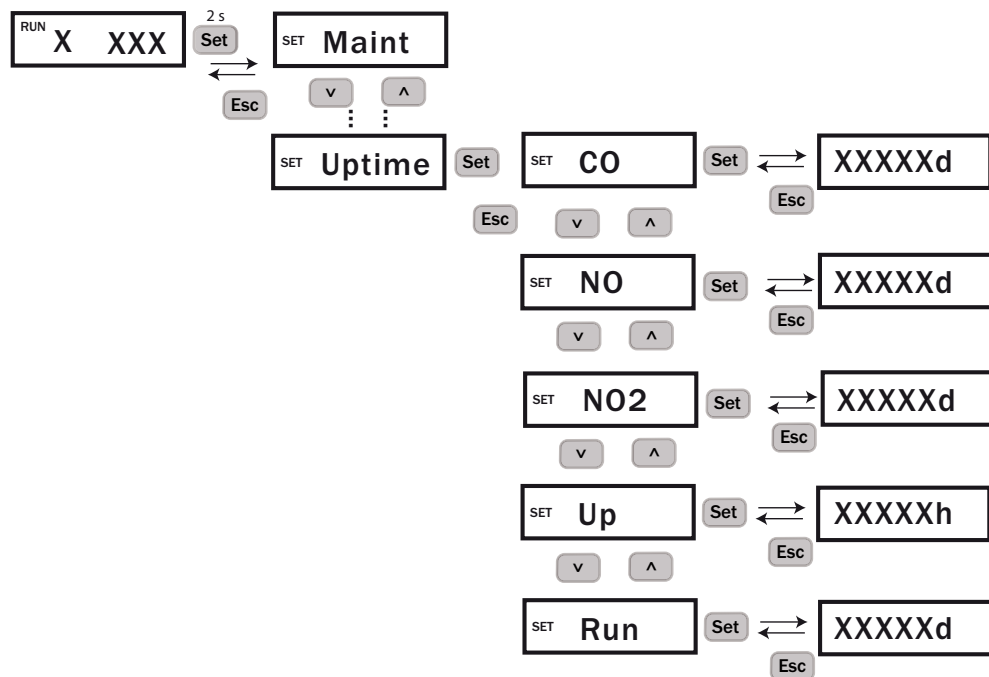

6.3.6 Calling up the software version in submenu item “SwVers”

The software version is shown as a 7-digit number and a 4-character change index.

Fig. 38: Calling up the software version

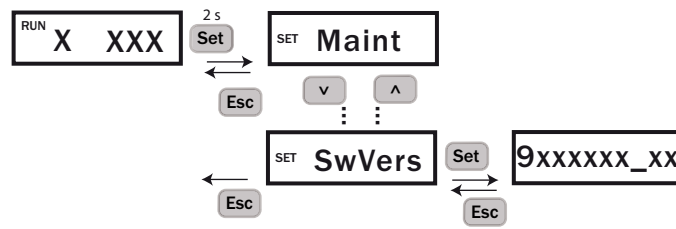

The software version is output as ticker text.

6.4 Connecting the bus systems

The VISIC100SF has an RS-485 output as standard. This can be used for a Modbus® connection to a central control system or to connect to the TAD control unit with integrated I/Os. The keypad serves to configure the RS-485 interface assignment.

6.4.1 Setting the RS-485 interface with submenu item “Bus”

Assignment of RS-485 interface:

- TAD control unit
- Modbus®
- IO (external modules)
- IO + TAD control unit (TAD control unit with integrated I/O modules)

A change of the RS-485 interface assignment is first effective after a restart.

Fig. 39: Selecting the RS-485 interface protocol

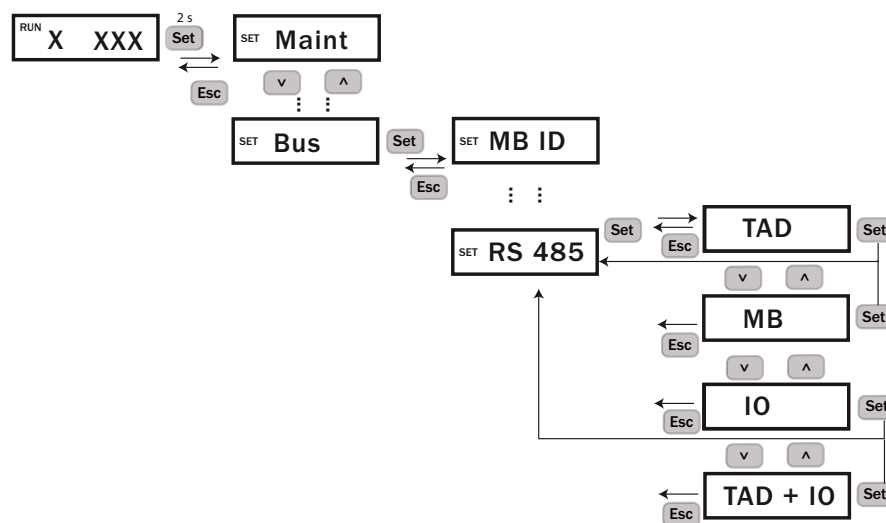

+i Only one assignment can be selected at a time.

+i A second RS-485 interface is firmly assigned to an optional PROFIBUS module, see [“PROFIBUS DP-V0 \(optional\)”](#), page 42.

6.5 Setting bus parameters

Menu item “Bus” serves to manage the parameters for the Modbus®, PROFIBUS and TAD control unit interfaces. A change to the bus system is first effective after a restart.



Press “Reset” to restart, see “Measuring unit - circuit board with display and keypad”, page 18.

6.5.1 Setting the PROFIBUS address in “PB ID”

The configured address is assigned to the VISIC100SF after a restart when the device is connected as “server” in a PROFIBUS-DP system. Submenu item “PB ID” serves to manage the PROFIBUS address. The valid address range is between 0 ... 126.

Arrow buttons: Increase and decrease the digits.

“Set” button: Activate next digit.



Submenu item “PB ID” is only available when the VISIC100SF has a PROFIBUS-DP module installed.

Fig. 40: Entering the PROFIBUS address

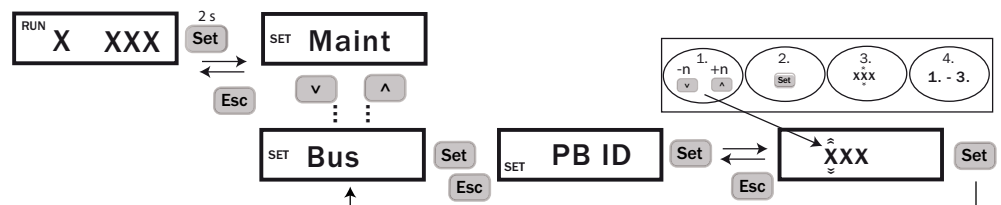

When the bus address has been entered completely, pressing “Set” switches the menu back directly to the “Bus” main menu.

6.5.2 Setting the Modbus® address in “MB ID”

The device address can be entered in menu item “Bus”, submenu item “MB ID” when the device is connected as “server” in a Modbus® system. The address range is between 1 ... 247.

Arrow buttons: Increase and decrease the digits.

“Set” button: Activate next digit. All digits must be confirmed. Call up the menu again to recheck the entry.

Fig. 41: Entering the device address

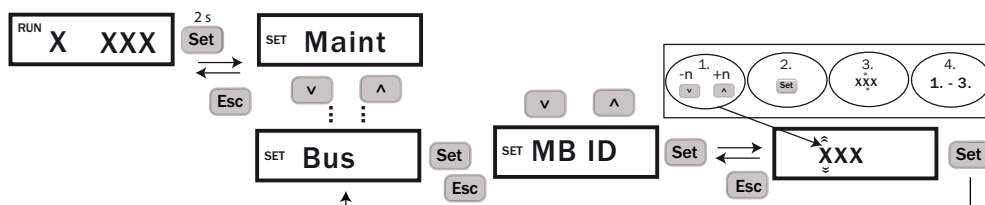

i When the bus address has been entered completely, pressing “Set” switches the menu back directly to the “Bus” main menu. The setting is saved when the VISIC100SF is restarted.
Press “Reset” to restart, see “Measuring unit - circuit board with display and keypad”, page 18.

6.5.3 Setting the Modbus® data transfer format with menu item “MB Par”.

Submenu item “MB Par” serves to set the Modbus® protocol parity:

- 1 start bit, 8 data bits, 1 stop bit, even parity (Even)
- 1 start bit, 8 data bits, 1 stop bit, odd parity (Odd)
- 1 start bit, 8 data bits, 1 stop bit, no parity (No 1 SB)
- 1 start bit, 8 data bits, 2 stop bits, no parity (No 2 SB)

Fig. 42: Setting the Modbus® protocol parity

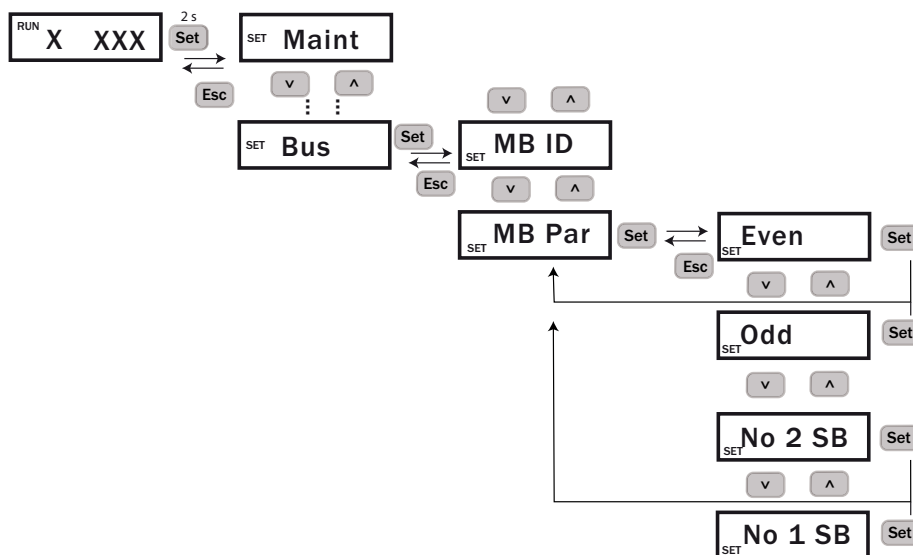

6.5.4 Setting the Modbus® baud rate with menu item “MB BdR”

Submenu item “MB BdR” serves to set the Modbus® interface baud rate:

- 4.8 k
- 9.6 k
- 19.2 k
- 38.4 k
- 57.6 k

Fig. 43: Setting the Modbus® interface baud rate

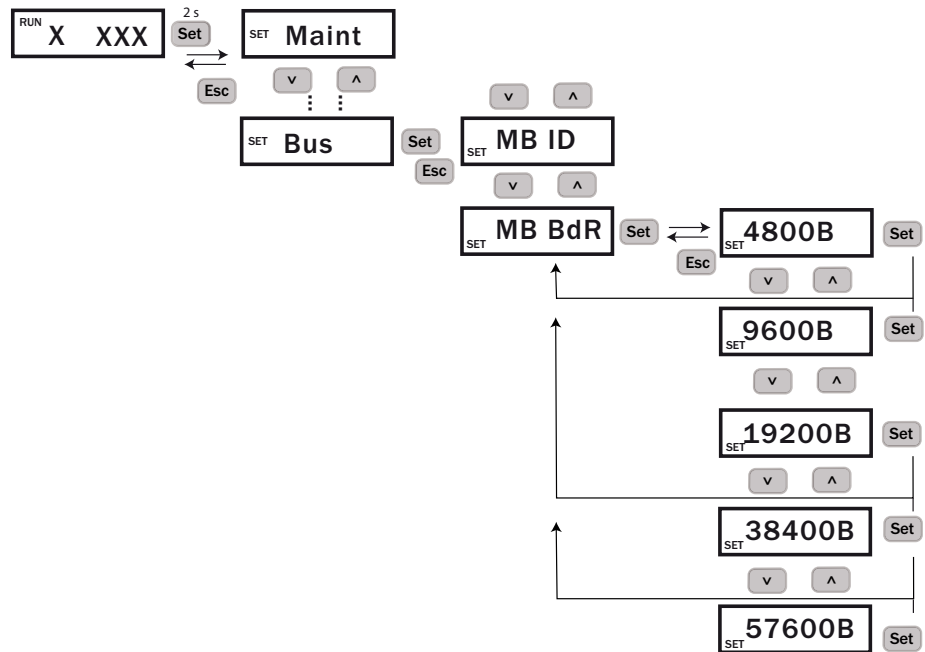

All “Bus” settings are first saved after a VISIC100SF restart.

6.6 Testing digital/analog outputs and gas sensors

The digital/analog outputs are tested under menu item “Test”.



Menu item “Test” is only available when menu item “Maint” has been set to active, see [“Activating the setting range via menu item “Maint””, page 53.](#)

6.6.1 Signal test “IO test”

The following signals can be set and/or tested:

- Analog output, factory setting AO1
- Analog output, factory setting AO2
- Analog output, factory setting AO3
- Analog output, factory setting AO4
- Relay for maintenance request (“MRq)
- Relay for device malfunction (“Fail”)



The configuration can be changed via the TAD control unit or the device display. AO4 is only available for TAD control unit with I/O modules. The VISIC has only 3 analog outputs.

6.6.1.1 Testing the analog output for the K-value with submenu item “AO1”

Fig. 44: Setting and checking the milliampere setting of the analog output for the “AO1” value

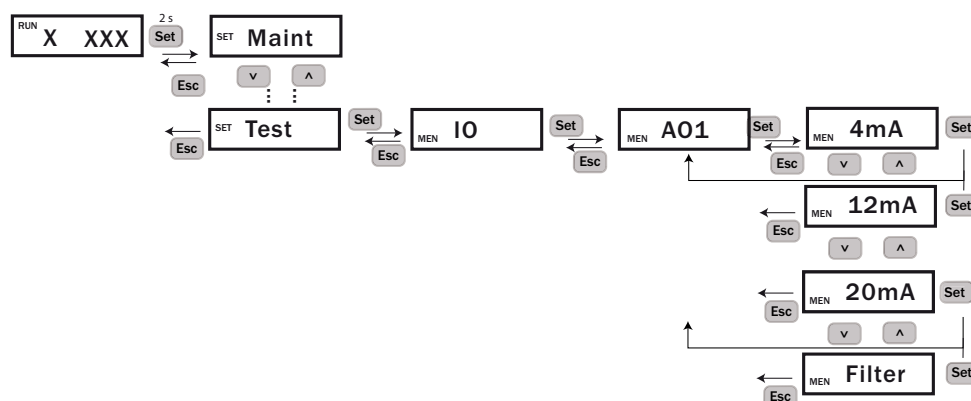

The factory setting for the K-value is AO1.
Caution: This configuration can be changed by the customer.



The selected current value is set only after the SET button has been pressed.



Submenu item “Filter” is required in connection with the test tool, description, see [“Menu navigation with keypad to submenu item “Filter””, page 92.](#)



The mA value set on the analog output can be reset using “Maint” -> “inactive”. After 30 minutes, the VISIC100SF switches back automatically to measuring mode, see [“Activating the setting range via menu item “Maint””, page 53.](#)

6.6.1.2 Testing the analog outputs for the gas sensors

Maintenance mode must be activated, see “Activating the setting range via menu item “Maint””, page 53.

Fig. 45: Setting the output current for A02 (factory setting: A02 = NO gas sensor)

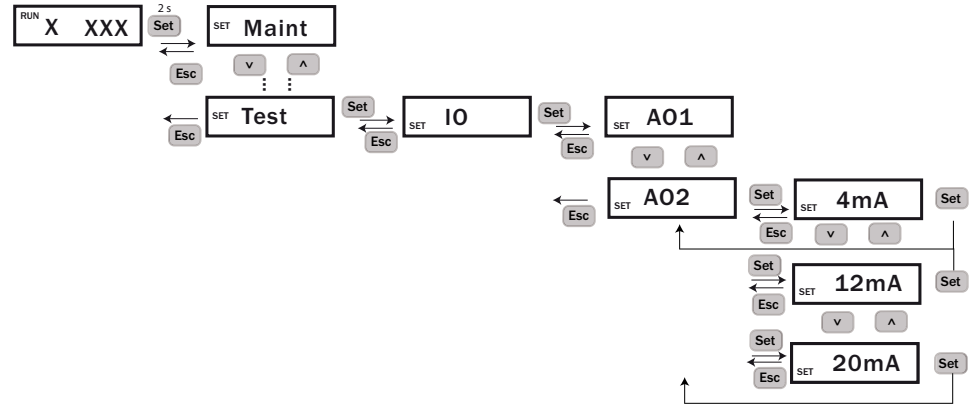
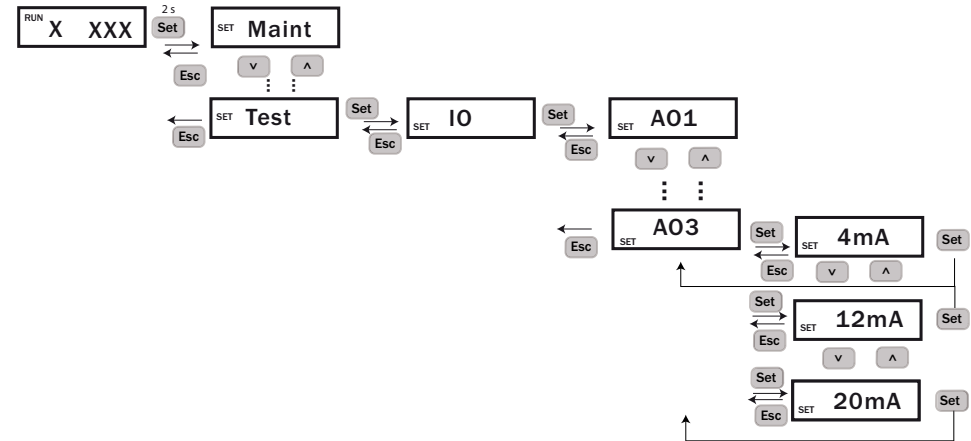
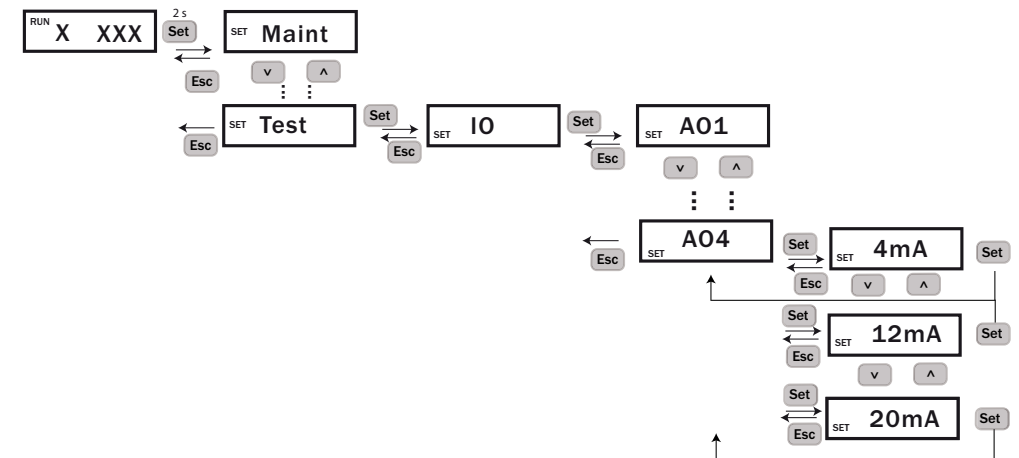

Fig. 46: Setting the output current for A03 (factory setting: A03 = CO)



6.6.1.3 Testing the analog outputs for the temperature measurement with submenu item “A04”

Fig. 47: Setting the output current for A04 (factory setting: A04 = temperature measurement)



6.6.1.4 Testing the “Maintenance request” relay with submenu item “MRq”

Maintenance mode must be activated.

Fig. 48: Setting and testing the maintenance request relay

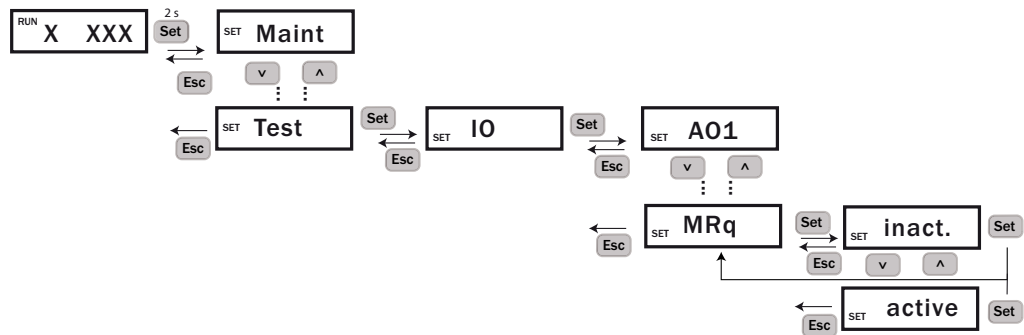

+i The set relay can be reset using “Maint” -> “inactive”. After 30 minutes, the VISIC100SF switches back automatically to measuring mode, see “Activating the setting range via menu item “Maint””, page 53.

6.6.1.5 Testing the malfunction relay with submenu item “Fail”

Maintenance mode must be activated.

Fig. 49: Setting and testing the device malfunction relay

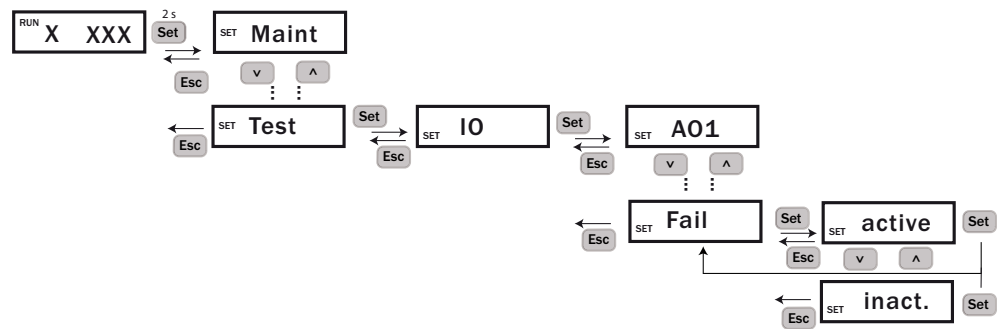

6.6.2 Assigning analog outputs with menu item “IOMap”

The assignment of analog outputs A01-A04 can be changed with menu item “IOMap”.

+i Factory setting:
 A01=VIS
 A02= NO
 A03= CO
 A04=Temp

! The VISIC100SF is equipped with analog outputs A01 - A03. The TAD control unit with supplementary I/O modules is required to implement a 4th analog output. All outputs are configured via the VISIC100SF or the TAD control unit.

Possible values for assigning analog outputs:

- k or μg
- CO
- NO
- NO₂
- Temperature

Fig. 50: Assigning analog outputs

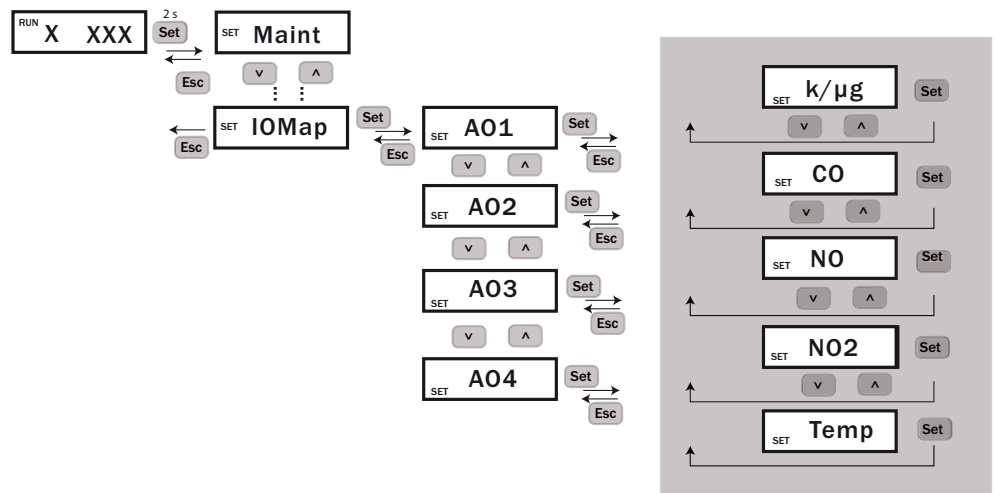

6.6.3 Scaling analog outputs

Fig. 51: Setting the scaling values for the analog outputs

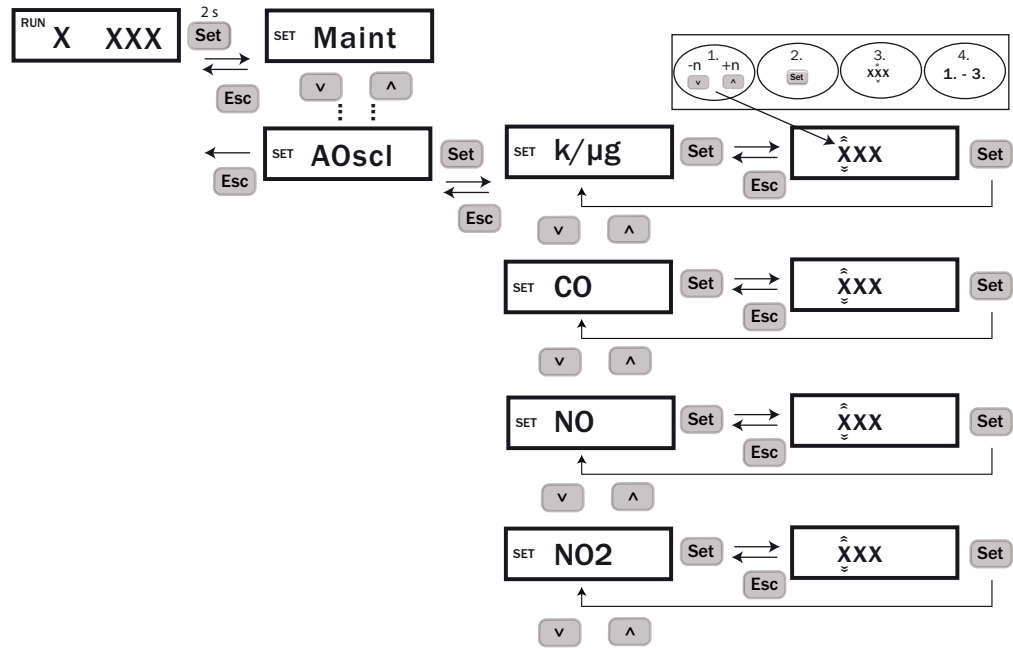

6.6.4 Output visibility as “K-value” or “µg”

Use menu item “k/µg” to set whether visibility is output as “K-value” or “µg”.



NOTE: When the dust concentration is activated, k becomes µg

For representation of visibility in µg, the values in the VISIC100SF display are not output as K-value but as µg.

The transmitted measuring range in µg is 0 to 1500µg.

Fig. 52: Output visibility as “K-value” or “µg”

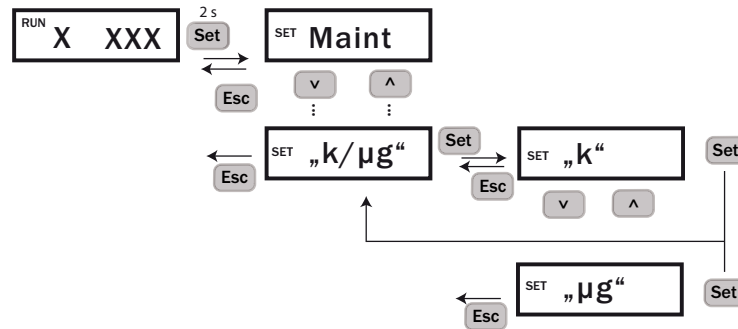

6.6.5 Activating/deactivating the external temperature sensor (optional)

The external temperature sensor (optional) is activated or deactivated in menu item “Temp”. When the external temperature sensor is activated, the temperature is output on the basic display of VISIC100SF. The temperature sensor is deactivated at the factory.

Fig. 53: Activating/deactivating the external temperature sensor

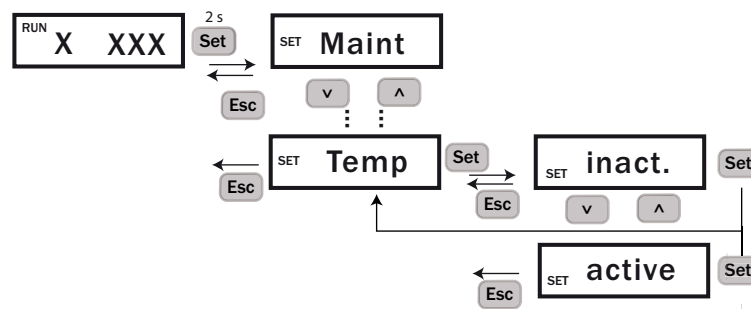

6.6.6 Activating/deactivating the heating (optional)

+i Menu item “Heat” is only available when menu item “Maint” has been set to “active”, see “Activating the setting range via menu item “Maint””, page 53.

The heating (optional) is activated or deactivated in the menu item “Heat”. The heating is only set to “active” at the factory when the device was ordered with heating.

Fig. 54: Activating/deactivating the heating (optional)

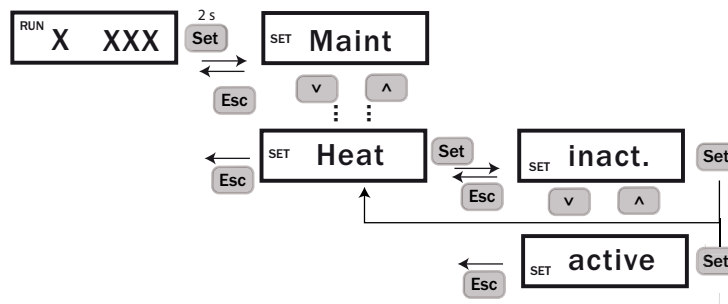

+i The heating is always activated when the measuring unit (2071119) is delivered as spare part.

6.6.7 Device adjustment using submenu item “Tuning”

+i Menu item “Tuning” is only available when menu item “Maint” has been set to “active”, see “Activating the setting range via menu item “Maint””, page 53.

Function for performing device adjustment onsite. Description of the visibility test with VIS test tool, see “Visibility test with VIS test tool”, page 89.

Fig. 55: Performing device adjustment

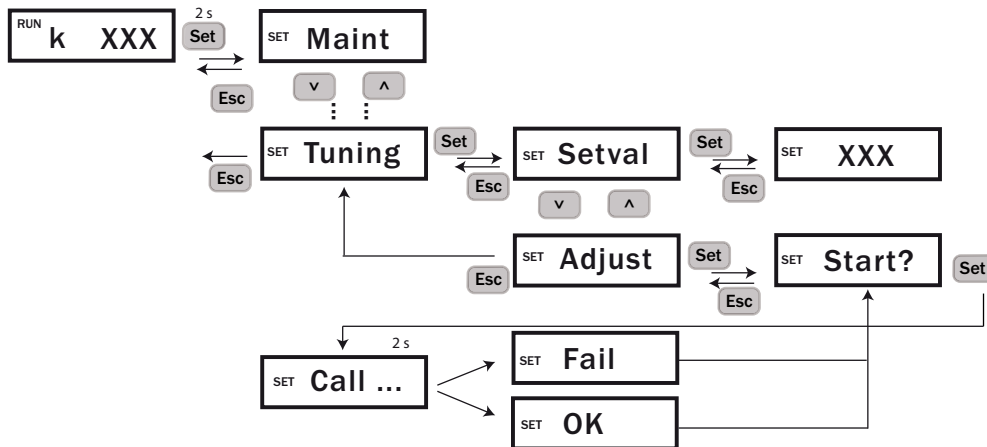

+i The test takes 2 seconds. Afterwards the display shows for 1 second whether the test was successful (“ok”) or not successful (“Fail”).

7 TAD control unit menu navigation



NOTICE: Incorrectly set parameters can lead to unsafe operation of VISIC100SF.

After a parameter change, check the newly set parameters. Ensure that the new parameters are set correctly.

7.1 Basic features

Purpose

The display unit of the TAD control unit is a remote control unit for configuration and display of the VISIC100SF values.

Interface

- Sensor buttons
- Context-sensitive button functions (see “Function buttons”, page 69)
- Display protected by glass plate

7.2 Main functions

Displays

- Measured value displays: Visibility, dust concentration, CO, NO, NO₂, temperature
- Measured values of several components
- 7 menu languages

7.3 Switch-on procedure

Switching on

- 1 Switch the VISIC100SF and the TAD control unit on (start main voltage supply).
 - »» The “POWER” LED of the TAD control unit goes on.
 - »» The Status LED on the VISIC100SF goes on.
- 2 Wait until the measuring screen appears, see “Initialization phase”, page 70.
- 3 Wait for the heating up phase to elapse, see “Operating elements”.
- 4 Check whether the VISIC100SF switches to measuring mode, see “LED display of the operating state”, page 48.

7.3.1 Characteristics of the heating up phase

Characteristic	Normal state
“POWER” LED “FAILURE” LED	On
Display	<ul style="list-style-type: none"> • CO and NO/NO₂ measured values blink^[1] • The left function button shows “Diag”.

[1] The respective gas sensor must have been installed.



- The electrochemical cells require approx. 30 minutes after switching on until the measured value is stable. The CO and NO/NO₂ measured values are identified by blinking as unreliable in this phase.
- The message “Warmup” is shown in the status bar in the heating up phase.

7.4 Operating elements

Fig. 56: Operating and display elements (with menu example)

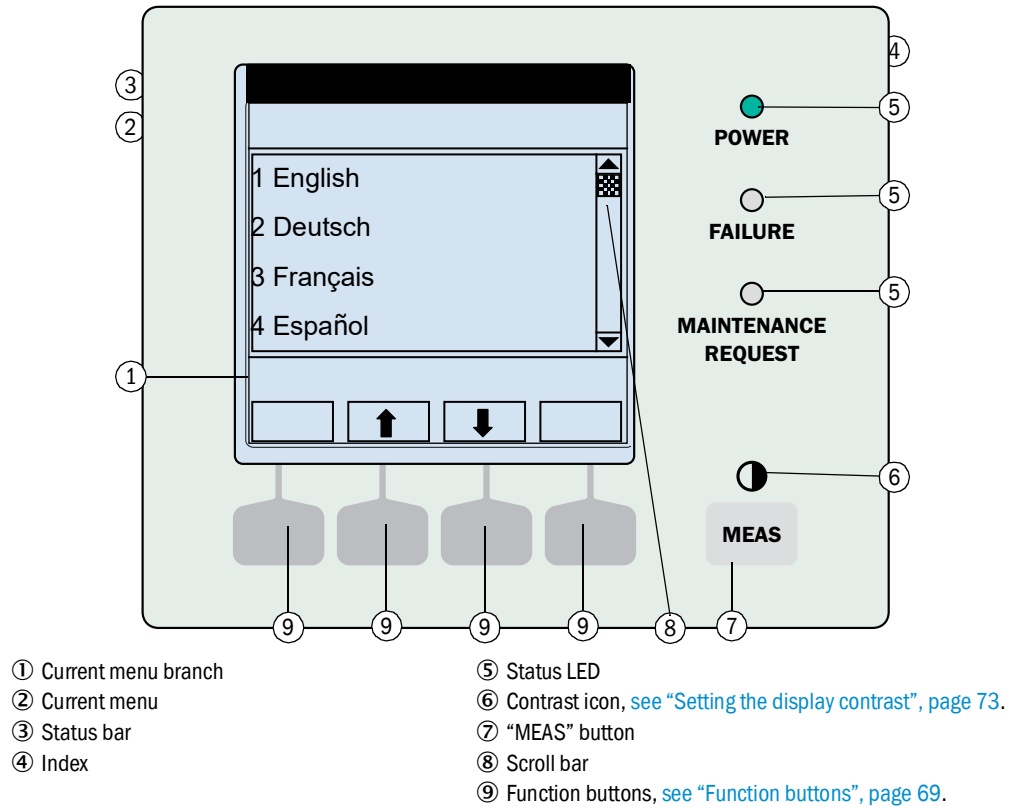



► *To activate a function button:* Simply touch the button surface with a finger.



The display lighting switches off automatically after 15 minutes.

7.4.1 LEDs

LED	Significance/possible causes
 POWER	The TAD control unit is switched on, power voltage is available.
 FAILURE	<ul style="list-style-type: none"> • At least one error code is active. • The "Maintenance operation" state is activated manually.
 MAINTENANCE REQUEST	A MRq code is active on at least one sensor.

7.4.2 Function buttons

The current function of the function buttons is shown on the display (example, see [“Operating and display elements \(with menu example\)”](#), page 68).

Display	Function
“Back”	Return to the previous menu (inputs not saved are lost)
“Diag”	Call up current device status
“Enter”	Call up/start selected menu function
“Menu”	Call up the Main menu
“Save”	Save input/exit
“Set”	Start setting
“Select”	Select function/character
“Start”	Start procedure
“Login”	Password required
↑	<i>In a selection list:</i> Move cursor upwards
	<i>During input:</i> Next character
↓	Move cursor downwards
←	Move cursor to the left
→	Move cursor to the right

Table 18: Possible function button functions

7.5 Starting operation

7.5.1 Initialization phase

After the voltage supply is switched on, the display unit performs the initialization phase.

Fig. 57: Display contents during the initialization phase

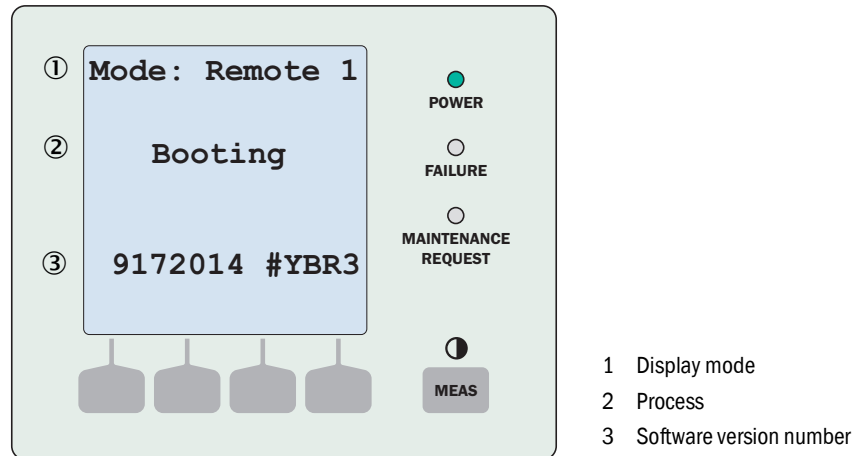

Changing the display mode

“Wait for communication” is shown on the display at the end of the initialization phase. The display mode is preset and must be Remote 1. Otherwise it must be changed accordingly.

- Press the “Mode” button for three seconds to change the settings.

Fig. 58: “Wait for communication” display text

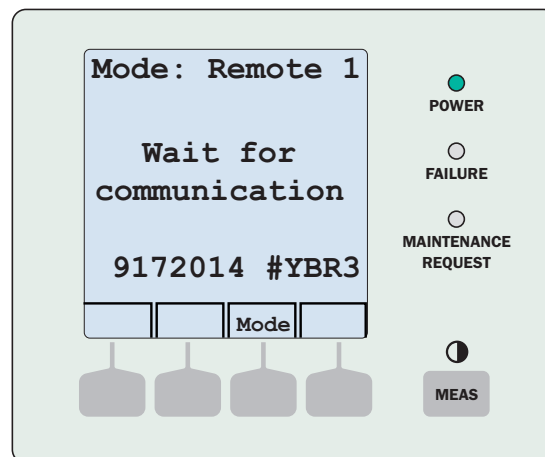

7.5.2 Measuring screen

List display and bar chart

Fig. 59: Measuring screen as a list

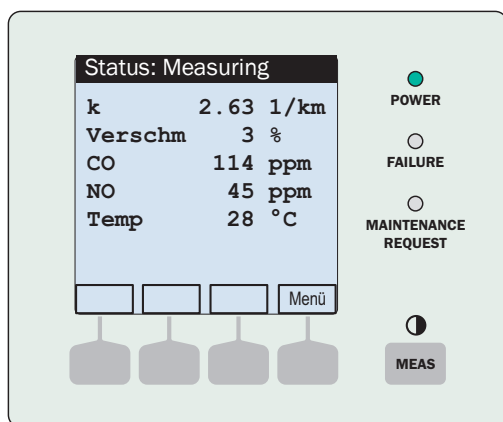

+i Only installed gas sensors are shown on the display. The temperature is displayed when a sensor was installed and parameter “Temp. on” has been set.

Fig. 60: Measuring screen as a bar diagram

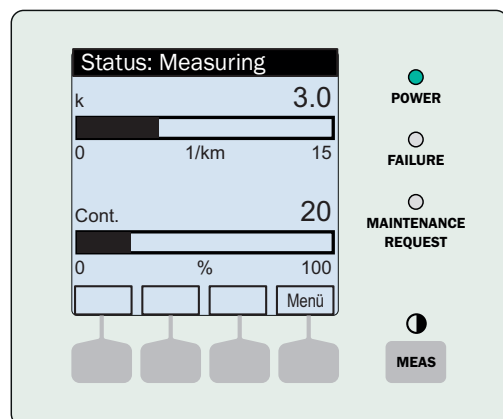

Options	Action
Selecting a different measuring screen:	▶ Touch “MEAS” until the desired measuring screen is displayed.
Switching the measuring component:	▶ Touch ↓/↑.
Switching to the menu:	▶ Select “Menu”.
When a measured value blinks or an error or a maintenance request exists.	▶ Select “Diag”.

+i The list display is automatically displayed after switching on.

7.5.3 Displaying the Main menu

- ▶ When the measuring screen is active, see [“Initialization phase”, page 70](#): Select “Menu”.
- ▶ Select the *Back* button to return from the menu to the measuring screen.

Fig. 61: Main menu

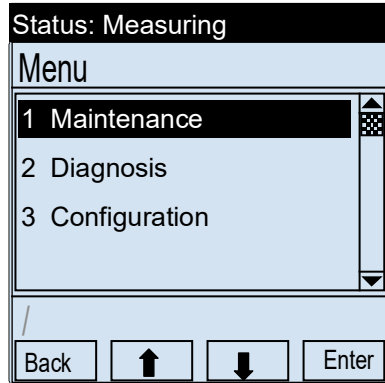

7.5.4 Selecting the menu item

- 1 Select the desired function: Select ↓/↑.
- 2 Select “Enter”, “Set” or “Save” (depending on the display).

7.5.5 Returning to the measuring screen

- ▶ Press the “MEAS” button. This is possible from any menu item.

7.5.6 Selecting the menu language

Configuration/Select Language

Fig. 62: Menu “Select Language” (example)

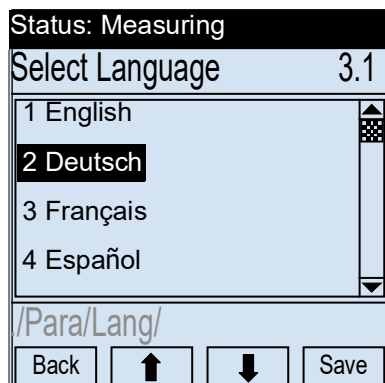

- ▶ Select the desired language (↓/↑, “Save”).



- Languages available: English, German, French, Spanish, Russian, Italian, Portuguese (Brazilian).
- The password must be entered to set the language.
Password input, see [“Changing numerical parameters \(password input\)”, page 73](#).

7.5.7 Setting the display contrast

- 1 Press the "MEAS" button for 3 seconds.
 - » The measuring screen appears first.
 - » Then the menu to set the contrast appears.

Fig. 63: Menu to set the contrast

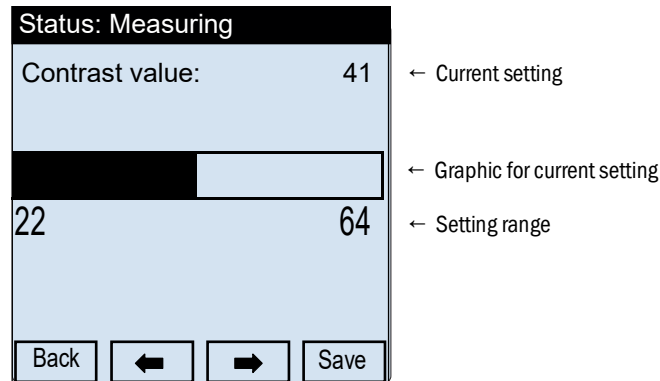

- 2 Select \leftarrow/\rightarrow until the desired setting is reached.
- 3 Save the values with "Save".

7.5.8 Changing numerical parameters (password input)

Fig. 64: Changing numerical parameters (example)

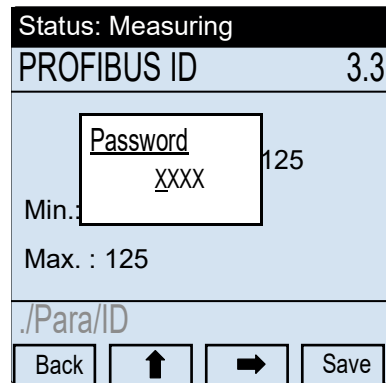

- 1 To move the cursor: Select \rightarrow .
- 2 To change the selected digit: Select \uparrow until the desired digit is displayed.
- 3 To set the displayed value: Select "Save".
- 4 To abort the process: Select "Back".



The password 1234 is predefined at the factory.

7.6 Activating Maintenance mode

The VISIC100SF is set to maintenance mode in the “Maintenance” menu item. This is required for:

- Maintenance work
- Function check with the VIS filter
- Function check of the gas cells with test gas

Fig. 65: Switching the maintenance signal on/off

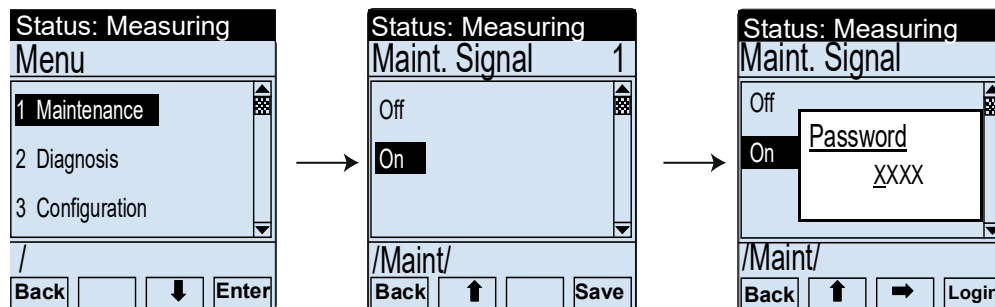

Password input, see “Changing numerical parameters (password input)”, page 73.
The four-digit password “1234” is predefined at the factory.

After the maintenance signal was activated, “Status Maintenance” is shown in the status bar. This status remains active for 30 minutes. All menu items remain accessible and executable.

Maintenance mode is terminated by setting the maintenance signal to “Off” or restarting the device.

7.7 Main menu item “Diagnosis”

The following data can be retrieved under main menu item “Diagnosis”:

- Next maintenance (gas cells)
- Uptime: Operating duration information
- Device Info
- Peripheral
- Messages: Current error and maintenance request messages
- Gas test: For performance of reference measurements of the gas cells
- I/O test: Test of analog and status outputs

Fig. 66: Main menu item “Diagnosis”

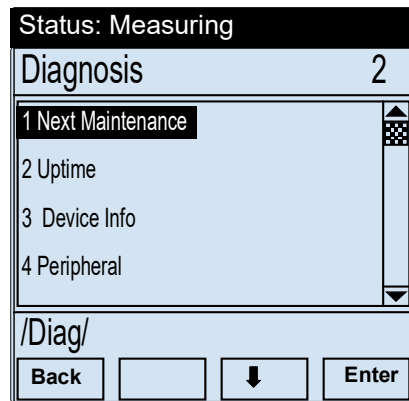

Current device errors can only be displayed via the “Diag” button or “Diagnosis/ Messages”.



When no gas sensors are installed, the submenu items “Next Maintenance” and “Gas Test” will not be displayed under menu item 2 “Diagnosis”.

7.7.1 Maintenance requests of gas sensors: “Next Maintenance”

The gas sensors (CO, NO and NO₂) have a counter which displays the time remaining to the next maintenance request of the gas sensors. A maintenance request is activated after an operating time longer than 365 days. Submenu item “Next Maintenance” serves to display the number of days remaining until the next maintenance request.



Abbreviations in the menu:
xxx d = number of days

Fig. 67: Display of the remaining time (in days) to the next maintenance request

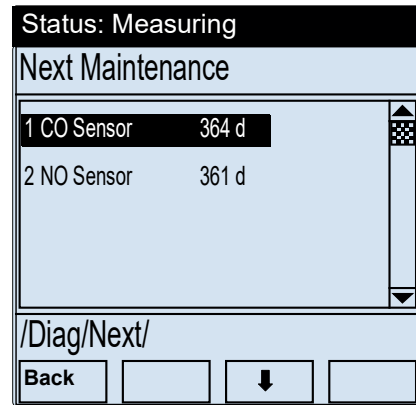

- Menu item “Next Maintenance” will not be displayed when no gas sensors are installed.
- Only installed gas sensors will be displayed.

7.7.2 Retrieving the operating duration: “Uptime”

Menu item “Uptime” retrieves the following information:

- Uptime: Number of operating hours (h) since the last switch-on.
- VISIC100: Operating duration since initial commissioning in days (d).
- CO sensor: Number of days (d) for the gas sensor currently in use.
- NO sensor: Number of days (d) for the NO sensor currently in use.
- NO₂ sensor: Number of days (d) for the NO₂ gas sensor currently in use.

Fig. 68: Calling up the operating duration

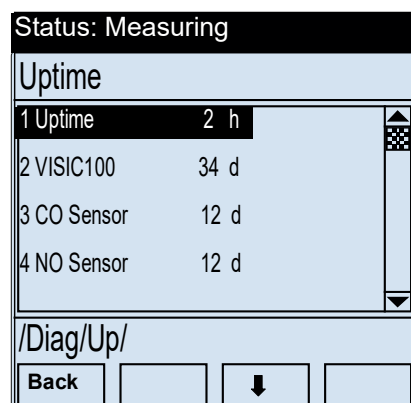

- “CO Sensor”, “NO Sensor” or “NO₂” are not shown under menu item “Uptime” when no gas sensors are installed.
- Only installed gas sensors will be displayed.

7.7.3 Retrieving device information with “Device Info”

The following device information can be retrieved under this menu item:

- Ser-No.: The serial number is shown with an 8-digit number.
- SW-Ver.: The software version is shown with a 7-digit product number.
- SW-Rev.: The revision index of the software version is shown with 4 characters. It can be numerical and/or alphabetical.
- SW CO, SW NO and SW NO₂: The software versions of the installed gas sensors are shown numerically.

Fig. 69: Retrieving the device information

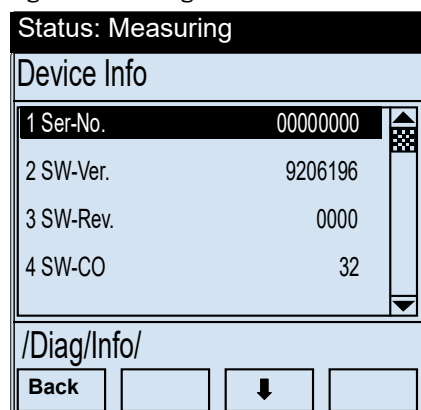

7.7.4 Retrieving the state of peripheral equipment with submenu item “Peripheral”

This menu item allows to check whether the following peripheral equipment has been activated:

- CO Sensor
- NO Sensor
- NO₂ Sensor
- Heating
- Temperature probe
- DO Module
- AO Module

Fig. 70: Retrieving the status information of the peripherals (example)

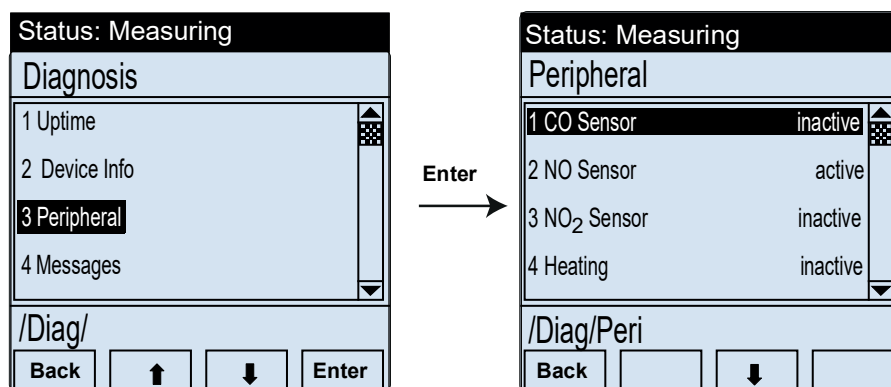

The status of the peripheral equipment cannot be changed in this menu item.

7.7.5 Error messages/maintenance requests with “Messages”

Two message groups exist:

- Fault
- Maintenance request

7.7.5.1 Error messages in submenu item “Fault”

Fig. 71: Retrieving malfunction messages in plain text (example)

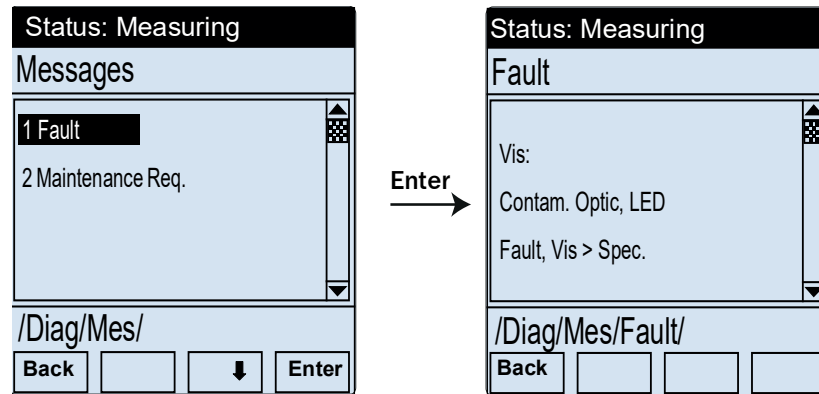

Error code Table, see [“Device error coding”](#), page 95.

7.7.5.2 Maintenance requests in submenu item “Maintenance Req.”

Fig. 72: Retrieving maintenance requests in plain text (example)

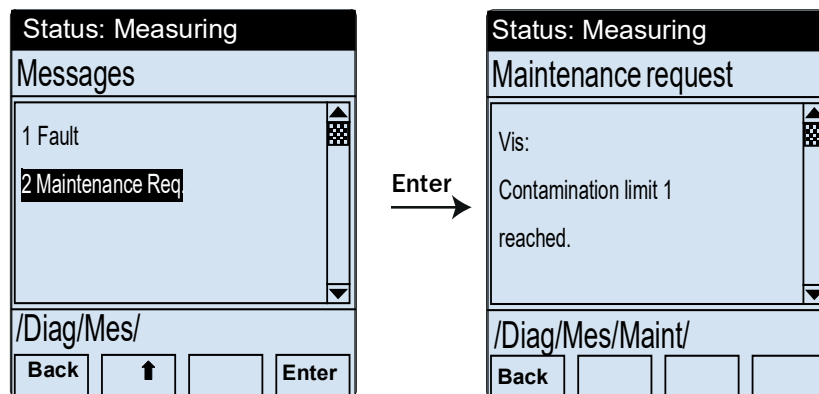

Table for explanation of specified codes under Maintenance request, see [“Description of maintenance requests”](#), page 96.

7.8 Testing digital/analog outputs

The digital/analog outputs are tested under menu item “IO Test”.

Signal test “IO test”

The following signals can be set and/or tested:

Analog outputs: Assignment of the analog outputs is preconfigured but can be changed manually, see “Assigning analog outputs “AO Mapping””, page 82.

Factory setting:

- AO1 = K-value
- AO2 = NO
- AO3 = CO
- AO4 = temperature

Relays

- Relay for device malfunction (“Fault”)
- Relay for maintenance request (“Maintenance Req.”)



NOTE: The maintenance signal must have been activated to test the digital and analog outputs and to set the values.

- ▶ Set the maintenance signal in the menu, see “Activating Maintenance mode”, page 74 or
- ▶ password prompt before setting the value, see “Switching the maintenance signal on/off”, page 74.



If the password is set to enable a function, all further settings can be changed within 30 minutes without having to enter the password again.

7.8.1 Testing the analog output AO1

Fig. 73: Setting and checking the rated current for AO1

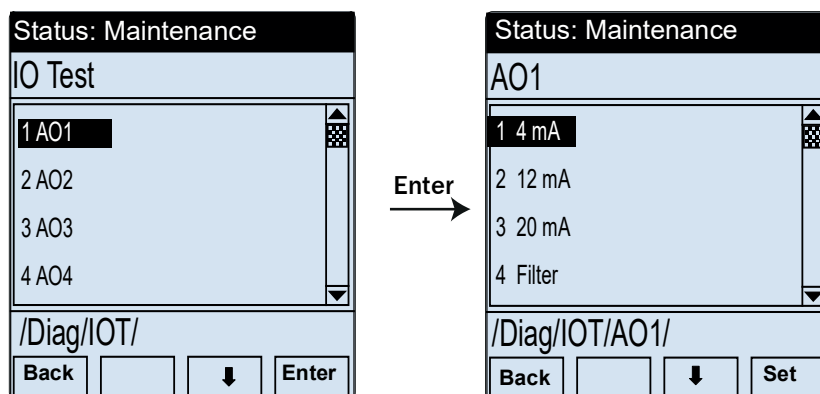

- ▶ Pressing the “Set” button outputs the value at the analog output.
- ▶ It is now possible to check at the analog output or in the control station whether 4mA is output on AO1 (factory setting K-value).



Submenu item “Filter” is required in connection with the test tool and is described in the Section “Maintenance”, see “Visibility test with VIS test tool”, page 89.



The rated current set on the analog output can be reset using “Maint” -> “inactive”. After 30 minutes, the VISIC100SF switches back automatically to measuring mode, see “Activating the setting range via menu item “Maint””, page 53.

7.8.2 Testing the analog outputs A02 - A04

Description, see [“Testing the analog output A01”, page 79](#).

7.8.3 Testing the “Fault” relay with submenu item “Fault”

Maintenance mode must be activated.

Fig. 74: Enabling the Fault relay

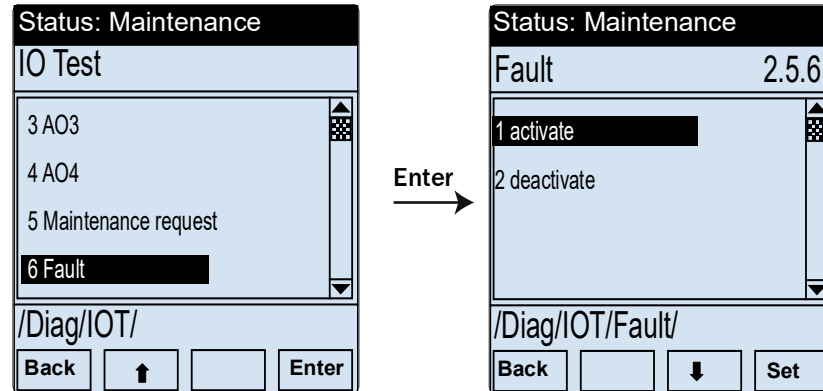

- ▶ Pressing the “Set” button activates the relay.
- ▶ It is now possible to check on the relay or in the control station whether the maintenance relay has been activated.

7.8.4 Testing the “Maintenance Request” relay with submenu item “Maintenance Req.”

Maintenance mode must be activated.

The relay for maintenance request is set the same as the relay for malfunction. Procedure, see [“Testing the “Fault” relay with submenu item “Fault””, page 80](#).

7.9 Performing settings on the device with menu item “Configuration”

The following settings can be performed via menu item “Configuration”:

- Select language (7 languages), see [“Selecting the menu language”, page 72](#).
- Scale AO
- AO Mapping
- PROFIBUS ID
- k/μg conversion
- Activate/deactivate temperature sensor



NOTE: The maintenance signal must be activated to change settings.

- ▶ Set the maintenance signal in the menu, see [“Activating Maintenance mode”, page 74](#) or
- ▶ password prompt before setting the values.

7.9.1 Scaling analog outputs with menu item “Scale AO”

Fig. 75: Scaling the analog output for k/μg

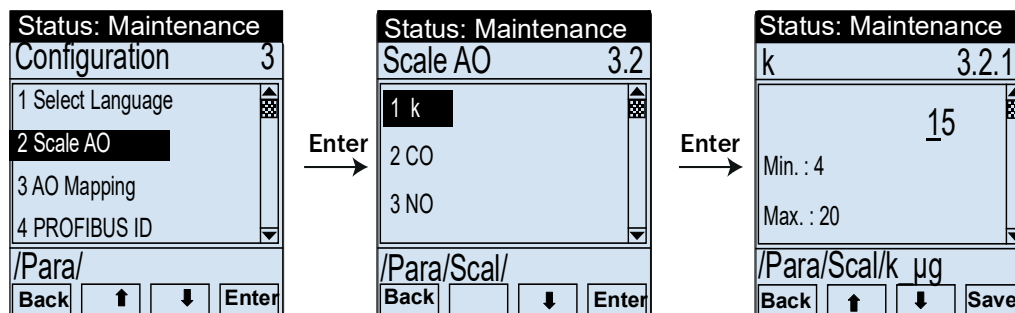

Fig. 76: Scaling the analog output CO

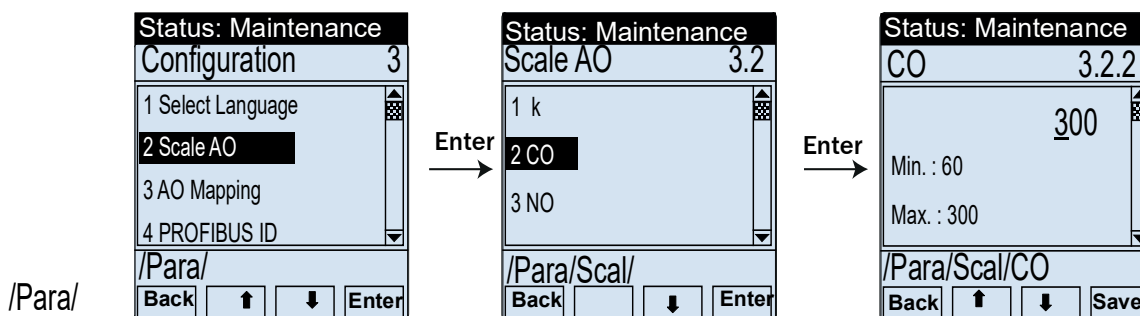

Fig. 77: Scaling the analog output NO

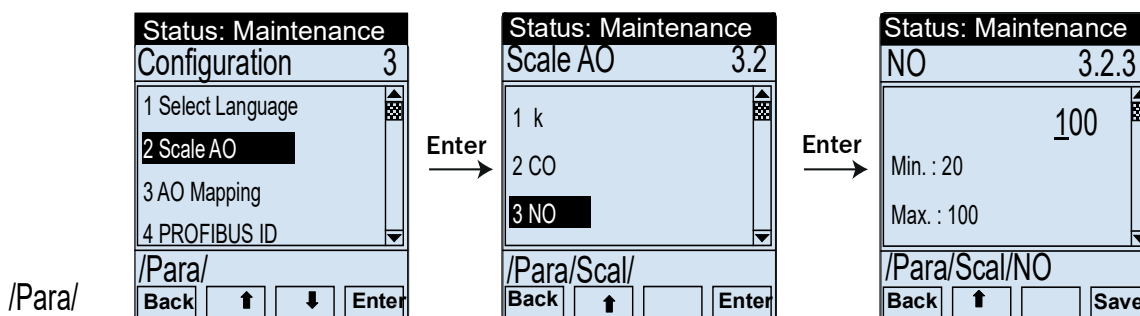
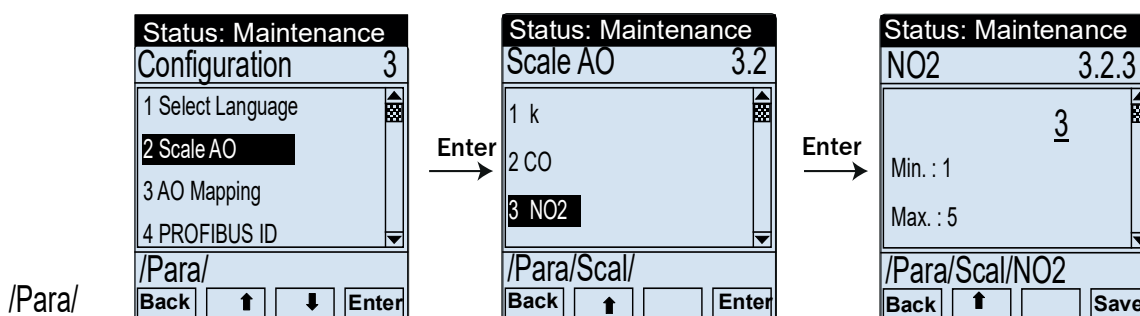

Fig. 78: Scaling the analog output NO₂



- ▶ Select the coefficient with “Enter”.
- ▶ Enter the required value.
- ▶ Save the value with “Save”.

7.9.2 Assigning analog outputs “AO Mapping”

The assignment of analog outputs AO1, AO2, AO3 and AO4 can be changed with the menu item “AO Mapping”.

Possible values for assigning analog outputs:

- k or µg
- CO
- NO
- NO₂
- Temperature



NOTE: For changing the preconfiguration, observe the following:

Fig. 79: Assigning analog output AO1

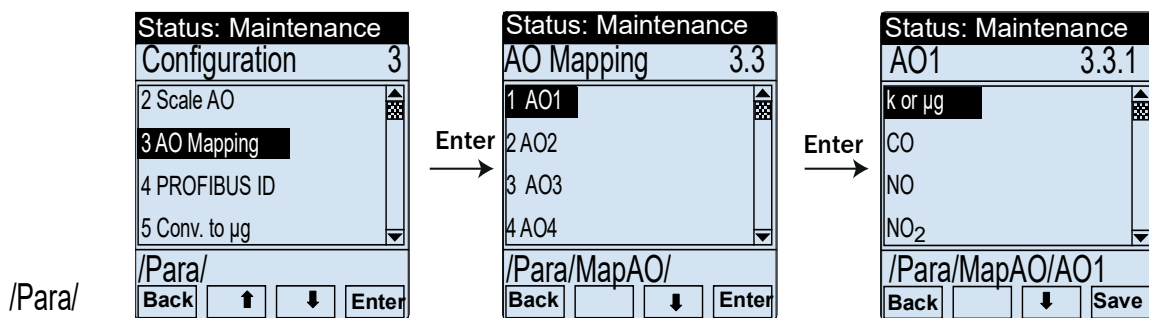

Fig. 80: Assigning analog output AO2

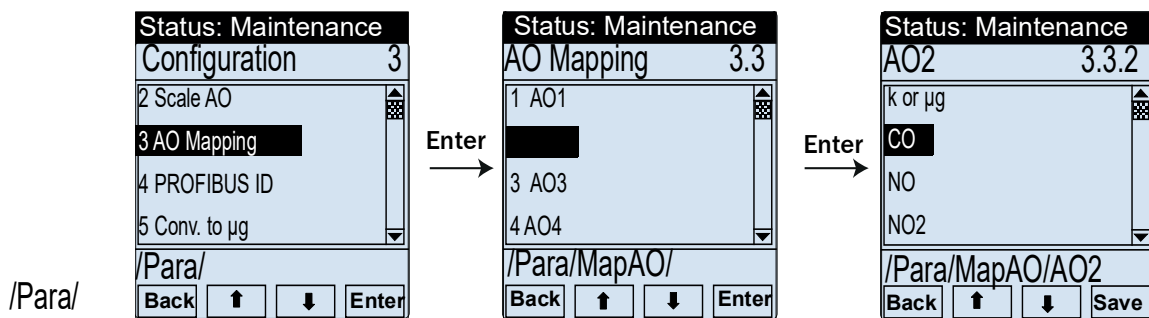

Fig. 81: Assigning analog output AO3

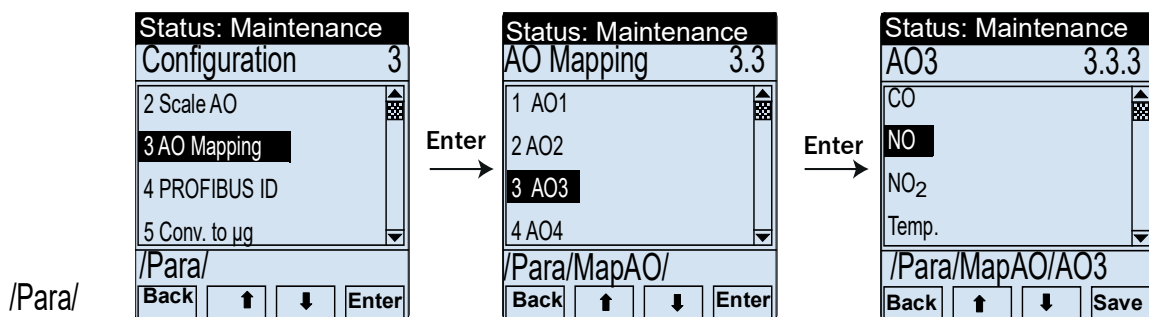
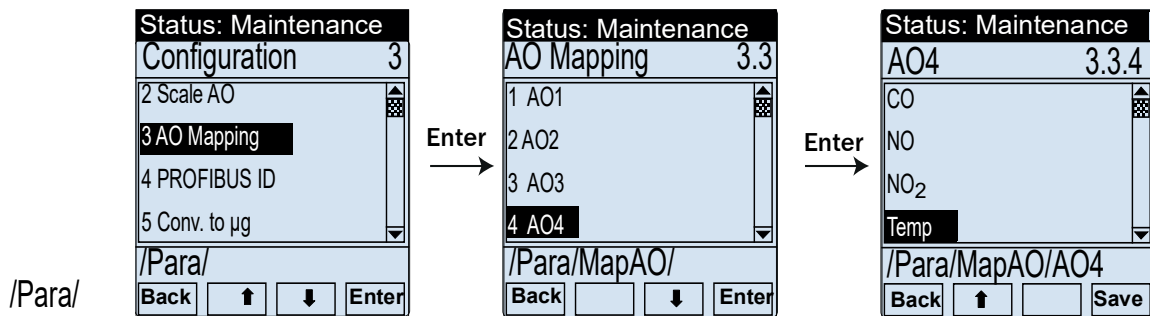

Fig. 82: Assigning analog output AO4



7.9.3 Setting the PROFIBUS address in “PROFIBUS ID”

The configured address is assigned to the VISIC100SF after a restart when the device is connected as “server” in a PROFIBUS-DP system. Submenu item “PROFIBUS ID” serves to manage the PROFIBUS address. The valid address range is between 0 ... 126.

Arrow buttons: Increase and decrease the digits.

“Right arrow button”: Activate next digit.

i The password must be entered to set the PROFIBUS address. Password input, “Changing numerical parameters (password input)”, page 73.

Fig. 83: Entering the PROFIBUS address

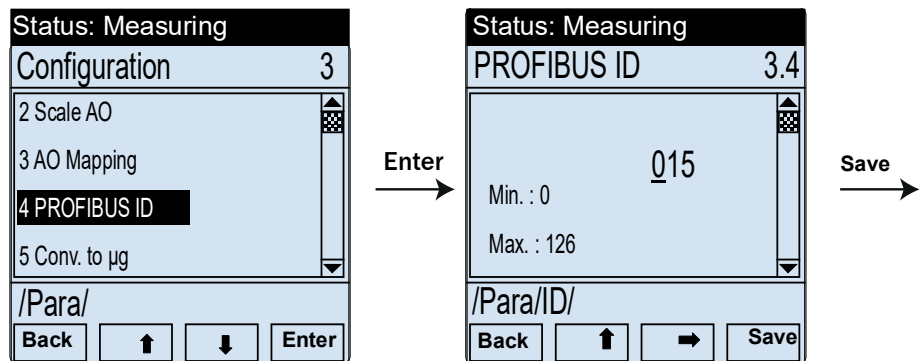

NOTE: The new address is only active after a system restart.

7.9.4 Conversion visibility/dust concentration with menu item “Conversion μg ”**NOTE: When the dust concentration is activated, k becomes μg**

For representation of visibility in μg , the values in the VISIC100SF display are not output as K-value but as μg .

The transmitted measuring range in μg is 0 to 1500 μg .

Parameter k/ μg defines whether the visibility or the dust concentration are to be output in μg on the display and the analog output. Both values are always output via the PROFIBUS and the Modbus®.

The coefficients for conversion of the K-value in a dust concentration are stored under menu item Coefficients.

The conversion is performed according to the following formula:

$$\mu\text{g} = a_0 + a_1 * k + a_2 * k^2$$

The values have the following default settings:

a0: -3.62 a1: 70.24 a2: 0.13

Fig. 84: Conversion k/ μg value

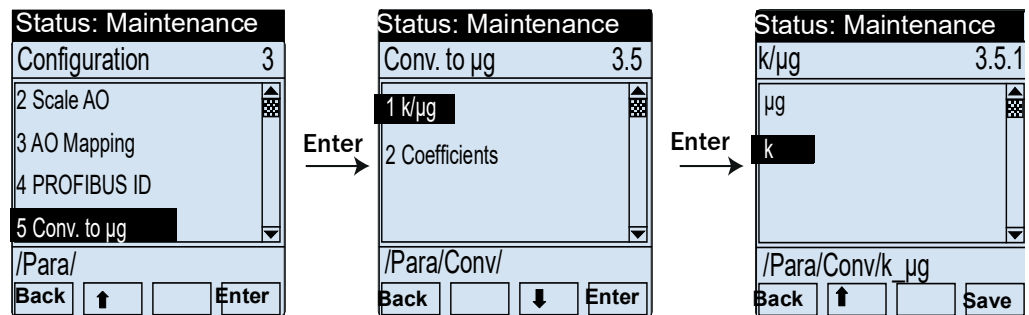
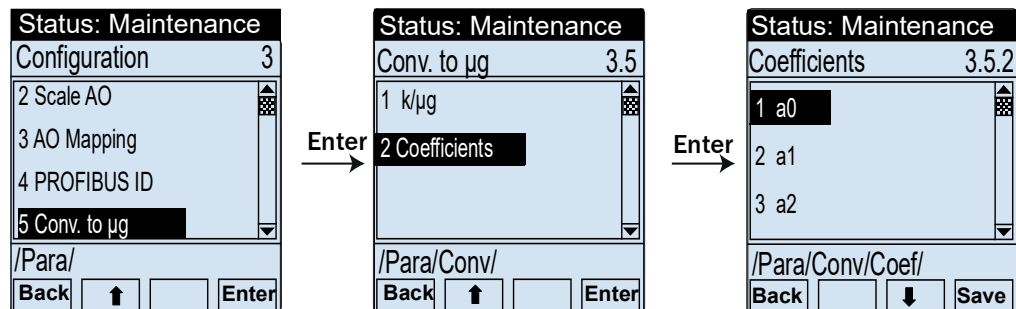

Fig. 85: Selecting coefficients for conversion k/ μg value



- ▶ Select the coefficient with “Enter”.
- ▶ Enter the required value.
- ▶ Use “Save” to save the value.

7.9.5 Activating/deactivating temperature measurement with menu item "Temp."

Fig. 86: Activating/deactivating temperature measurement

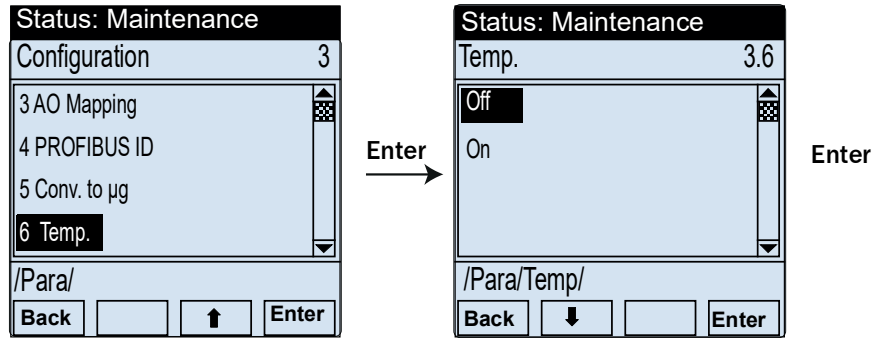

8 Shutdown

8.1 Technical knowledge necessary for shutdown

Shutdown may only be performed by trained technicians or an Endress+Hauser Service technician. Comply with the applicable tunnel regulations.

8.2 Safety information

**WARNING: Risk of burns on the VISIC100SF with fog dissipation**

Inner side: The heating element can heat up to 90 °C

Outer side: Can heat up to 80 °C in the vicinity of the inlet openings.

- ▶ Avoid touching the heating element without protective gloves.

**WARNING: Preventive measures for operating safety**

The VISIC100SF is normally used together with control technology.

- ▶ Ensure shutting down the VISIC100SF cannot lead to any danger or hindrance to traffic.
-

8.3 Preparations for shutdown

- ▶ Inform all concerned.
- ▶ Disable/deactivate safety devices.
- ▶ Clarify measuring point access (tunnel closure, lifting platform ...).

8.4 Switch-off procedure

The VISIC100SF can be switched off by interrupting voltage supply. There is no switch-off procedure to be observed.

8.5 Protective measures for shutdown device

- ▶ Store and transport the VISIC100SF in the original packaging.
- ▶ Remove the gas sensors and store in the shipping packaging. Observe the maximum allowable storage duration before using again.
- ▶ Pay attention to storage conditions. More information, see [“Technical Data”](#), page 103.

8.5.1 Measures for short-term shutdown

- ▶ Pay attention to the storage conditions for the measuring unit, the TAD control unit and the gas sensors.
- ▶ Store gas sensors airtight.

8.6 Transport



NOTE: Damage to the VISIC100SF, the TAD control unit and the connection unit

The VISIC100SF and the connection unit/TAD control unit can be damaged when dropped or through heavy impacts during transport.

- ▶ Use the delivery cartons for transport.



NOTE: Damage to the measuring unit through electrostatic discharges

When the measuring unit is transported separately (e.g. returning for repair or spare parts delivery), ESD damage caused by incorrect packaging can lead to severe damage to the electronics.

- ▶ Always transport the measuring unit in the ESD protected packaging provided.

8.7 Disposal

- ▶ The device can easily be disassembled into its components for disposal at appropriate raw material recycling facilities.



The following assemblies contain substances that may have to be disposed of separately:

- *Electronics*: Condensers
- *Display*: Liquid of LC-Display
- Electrochemical sensors



WARNING: Chemical burns by sulfuric acid

The gas sensors contain small amounts of liquid sulfuric acid. Skin and eye burns can occur through direct contact.

- ▶ Never open the enclosures of the gas sensors during disposal.

9 Maintenance

9.1 Technical knowledge, required

Maintenance going beyond the tasks described here must be performed by authorized technicians only and is described in the Service Manual.

9.2 Safety notes



NOTE: Risk of erroneous device function when using wrong spare parts.

- ▶ Use original Endress+Hauser spare parts only.
-



WARNING: Hazard by voltage.

Live parts are accessible when the device is open!

- ▶ Switch the supply voltage off before opening the device.
 - ▶ Only use suitable, insulated tools.
-



WARNING: Risk of accidents by missing safety precautions

- ▶ Before starting any maintenance work on the device, make sure that all tunnel-specific safety precautions have been taken.
-

9.3 Maintenance

9.3.1 VISIC100SF maintenance

Regular maintenance: 1 x per year.

9.3.1.1 Clean device inside and outside



NOTE: Avoid contamination of the measuring unit when opening

► Clean outer surfaces of device before opening.



NOTE: Preventive measures against ESD

Maintenance of the VISIC100SF may only be carried out by a skilled technician.

► Observe the applicable ESD Guidelines.

- Clean the outside of the VISIC100SF with a damp cloth before opening.
- Ensure the air inlet openings are not blocked.
- Clean the inside of the cover.
- Then carefully clean the inside of the device with a clean cloth.

9.3.1.2 Clean optics

Fig. 87: Cleaning optical interfaces

Tools required

- 1 x hex key
(ball head SW4)
- 1 x cotton swab

- ① Receiver unit
- ② Sender unit
- ③ Aperture
- ④ Light trap
- ⑤ Protective tube
- ⑥ Cylinder screw M5

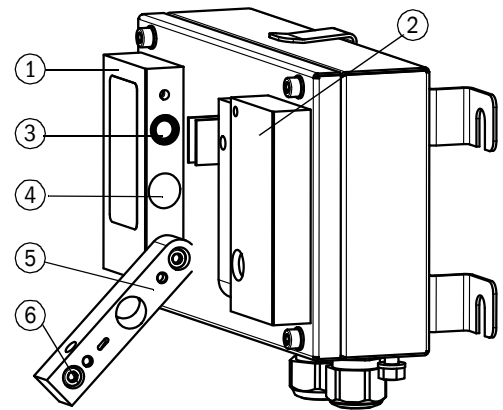

- 1 Loosen cylinder screw (6) at the upper end of the protective tube.
- 2 Open the protective tube.
- 3 Clean the optical interfaces and optical beam path in the protective tube with a cotton swab.
- 4 Close the protective tube and fasten the cylinder screw again.
- 5 Repeat the procedure on the opposite side.
- 6 Clean the light trap.

9.3.1.3 Visibility test with VIS test tool

Two k-value test tools are available to check the visibility value.

- One test tool in value range $k = 0 \dots 7 / \text{km}$ (test set, Part No. 2071542)
- One test tool in value range $k = 7 \dots 15 / \text{km}$ (test set, Part No. 2071541)

Fig. 88: Test tool for checking the visibility value



Procedure

- 1 Using the hex key SW4, unscrew the two screws on the enclosure cover, take the cover off and insert it in the fixture provided.
- 2 When the enclosure cover is opened, the VISIC100SF changes to operating state Fault.
- 3 Unscrew and fold open the measuring unit.

Fig. 89: Open VISIC100SF without gas sensors

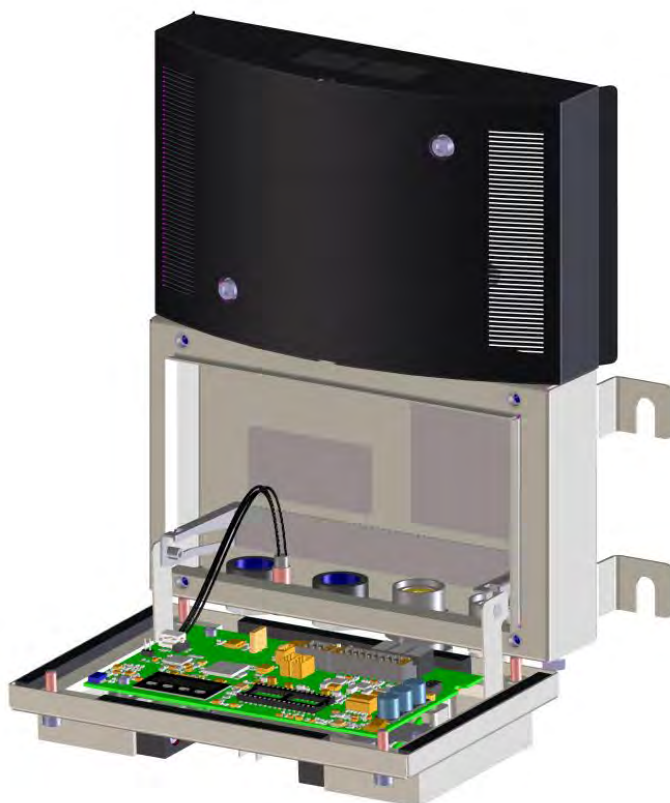

- 4 Switch to Maintenance mode via the display:

Fig. 90: Activating the setting range via menu item "Maint"

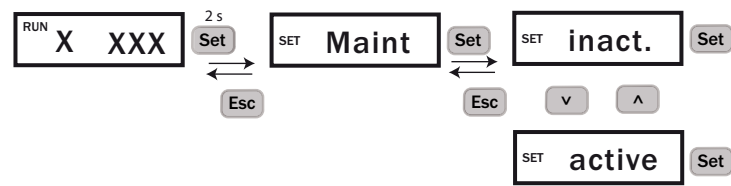

+i Mode "active" is reset to "inactive" after 30 minutes.

+i The malfunction relay is activated when mode "active" is set. The Status LED is red, the analog outputs output 1 mA and the field bus interfaces signal an error. The Maint LED on the circuit board is green.

- 5 Tip measuring unit up.
- 6 Insert the test tool between sender and receiver.

Fig. 91: Test tool positioning

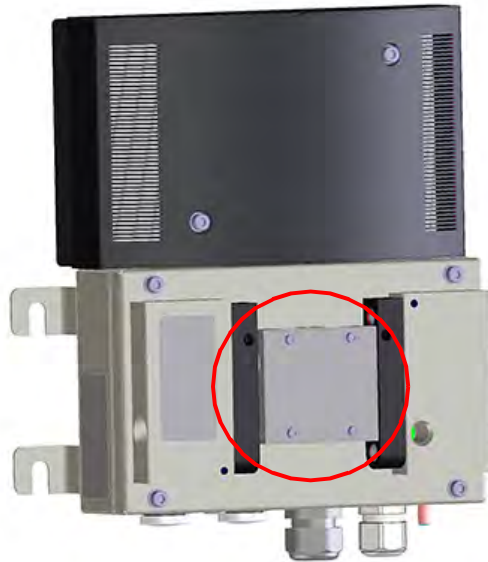

- 7 The test tool shows the rated value.
- 8 Open the measuring unit again and read the actual value on the display.
- 9 Allowed deviations:
 - Allowed deviation from actual value: $\pm 1/ \text{km}$.
- 10 If the actual value is within the tolerance, remove the test tool and set the Maintenance mode to inactive again.
- 11 Close the device and attach enclosure cover.

Actual value outside tolerance limits

- 1 Clean all optical interfaces on the device and on the test tool.
- 2 Check that the test tool is inserted correctly.
- 3 Repeat the test.
- 4 Actual value is still outside the tolerance limit: If possible, insert the test tool in other devices to exclude a defect of the test tool.
- 5 Replace the measuring unit or send it to Endress+Hauser for repair.

Special case: Actual value is to be output via the analog output for reading

Submenu item “Filter” must be activated via the keypad on the VISIC100SF to enable transfer of the values to the central computer in the control station.

By activating submenu item “Filter”, the actual value is not only shown on the display but also output on the analog output.

Fig. 92: Menu navigation with keypad to submenu item “Filter”

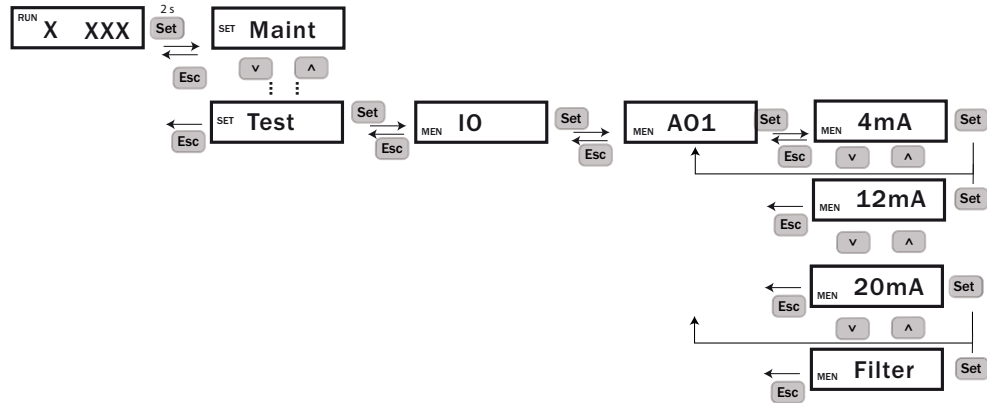

Afterwards, perform test as described above.



NOTE: Check correct wiring of malfunction relay

The test value is shown as actual value if the malfunction relay is not connected and causes an incorrect ventilator control.

9.3.1.4 Gas sensor maintenance



WARNING: Health risk through sulfuric acid

The gas sensor contains sulfuric acid.
 ▶ When taking the gas sensors out, avoid any damage by a pointed or sharp object. Package the gas sensors carefully and securely when damaged and dispose of as hazardous waste.

Exchanging the gas sensors

- 1 Switch the VISIC100SF off.
- 2 Open the VISIC100SF enclosure:
 - ▶ Unscrew the two screws on the enclosure cover with the SW4 hex key.
 - ▶ Remove the enclosure cover on the front side of the device.
 - ▶ Unscrew the four screws of the measuring unit.
 - ▶ Hang the measuring unit in using the hinge fixture and swivel it downwards.
- 3 Disconnect the connecting cable from the circuit board.
- 4 Unscrew the loose sensor by hand. If the sensor is stuck, loosen it with an open-end wrench SW27.
- 5 Gas sensor disposal, see “Disposal”, page 87.
- 6 Commissioning of new sensor, see “Mounting and commissioning of the gas sensors (optional)”, page 26.

9.3.1.5 Recalibration of gas sensors

Gas sensors can be recalibrated with the optional gas adjustment kit PN: 2125690.

9.3.2 Maintenance plan

Maintenance by trained users/Customer Service of manufacturer

Maintenance interval	Maintenance work
Yearly	
✓	▶ Clean device inside and outside
✓	▶ Clean optics
✓	▶ Replace or recalibrate gas sensors
✓	▶ Test analog outputs
✓	▶ Test digital outputs



▶ Also observe the local statutory and works regulations which apply for the individual application.

9.3.3 Tunnel cleaning

The device is protected during tunnel cleaning with degree of protection IP6K9K. However, ventilator control could be influenced by increased measured values.

- ▶ Set the device or the complete ventilator control to Maintenance or Manual during tunnel cleaning.



NOTE: During cleaning, the measured values may not be used for ventilator control.

9.4 When requesting Customer Service from Endress+Hauser

Request the Endress+Hauser Customer Service in writing to the responsible office 4 weeks before the planned maintenance date at the latest. Before this date, the customer must ensure:

- Safe access to, and safeguarding the mounting and workplaces in the tunnel. The tunnel/traffic lane should be closed when necessary.
- Provision of a lifting platform or a ladder and adequate lighting at the installation locations.
- Availability of a skilled technician with knowledge of local conditions.



Inform Service about malfunctions or potential repairs as early as possible. The Service engineer can then have the spare parts and consumables available that may be necessary for the maintenance date and thus avoid unnecessary and expensive multiple journeys.

9.4.1 Exchanging the measuring unit

The measuring unit can be exchanged onsite in an error case.

- 1 Disconnect the VISIC100SF from the voltage supply.
- 2 Remove the plug-in connectors:
 - Voltage supply
 - Analog outputs
 - Relay outputs
 - Connection terminal strip RS485
 - LED plug
 - Electrochemical cells
- 3 Unhinge the defective measuring unit.

4 Hinge the new measuring unit and reconnect the plug connections.



NOTE:

In case the interface parameters, assignment of analog outputs, activation of the heating or temperature sensor have been set during commissioning, they have to be set anew for the new measuring unit.

9.5 Spare parts



WARNING: Malfunction hazard

► Use original Endress+Hauser spare parts only.

9.5.1 Consumable parts/operating materials

Consumable material	Item number
CO sensor 200 ppm	2121389
CO sensor 300 ppm	2121387
NO sensor	2121386
NO ₂ sensor	2121388

9.5.2 Spare parts for VISIC100SF

Spare part	Item number
Measuring unit	2071119
Enclosure cover, standard	2071120
Enclosure cover with heating	2071121
Connection terminal strips ^[1]	2076810
Cable gland M20 x 1.5 D6-12	2071122
Cable gland M20 x 1.5 D10-14	2071123
Screw plug	2071124
Sender tube	2073957
Receiver tube	2073956
PCB PROFIBUS	2073009

[1] 6 and 18 pin, pluggable. Ferrules are provided for on-site wiring.



The standard enclosure cover and enclosure cover with heating cannot be swapped onsite.

10 Clearing malfunctions

10.1 Description of device errors

The VISIC100SF switches immediately to Malfunction when a device error occurs. In operating state Malfunction, the malfunction relay opens and the three analog interfaces signal 1 mA. The digital interfaces (PROFIBUS and Modbus®) verfügen have a measured value status which switches to “Bad” when an error occurs. The following Table shows the error codes displayed for possible device errors.



Information on calling up error codes on the display, see [“Calling up maintenance request and malfunction messages with menu item “Status””, page 53.](#)

Table 19: Device error coding

Code	Bit	Description	Cause	Notes for service
F_000	0	VIS error	Contam. Optic. LED Fault. VIS>Spec.	Clean and restart device. Exchange measuring unit. (via Endress+Hauser Customer Service).
F_001	1	CO sensor	CO Sensor Fault, Warmup Sensor.	Wait for heating up time to complete. Restart. Exchange gas sensor.
F_002	2	NO sensor	NO Sensor Fault, Warmup Sensor.	Wait for heating up time to complete. Restart. Exchange gas sensor.
F_003	3	EEPROM	EEPROM Data Inconsistent.	Restart. If the error is still present after a restart, call Endress+Hauser Customer Service or return the device, and specify the error code.
F_004	4	Heating	Enclosure cover not fitted because voltage supply interrupted -> no heating error. Heating Current Out Of Spec	Fit the enclosure cover. Restart. If the error is still present, call Endress+Hauser Customer Service. Exchange cover.
F_005	5	Erroneous function of analog interfaces	Electronic Fault.	Restart. If the error is still present after a restart, call Endress+Hauser Customer Service or return the device, and specify the error code.
F_006	6	FPGA	FPGA Fault, ADC Overload.	Restart. If the error is still present after a restart, call Endress+Hauser Customer Service or return the device, and specify the error code.
F_007	7	CPU	RAM Test Fault. Flash Test Fault. Register Test Fault.	Call Endress+Hauser Customer Service or return the device, and specify the error code.
F_008	8	Program flow	Program Flow Fault.	Restart. If the error is still present after a restart, call Endress+Hauser Customer Service or return the device, and specify the error code.
F_009	9	Enclosure error	Enclosure Cover not Fitted.	Fit the enclosure cover.
F_010	10	NO ₂ sensor	NO ₂ Sensor Fault, Warmup Sensor.	Wait for heating up time to complete. Restart. Exchange gas sensor.
F_014	14	Maintenance	Maintenance Active.	Deactivate maintenance on device, see “Activating maintenance in menu item “Maint””, page 53.



The status is always shown in plain text on the basis display.

10.2 Description of maintenance requests

Table 20: Description of maintenance requests

Code	Bit	Description	Coding Maintenance requests	Notes for service
MRq_000	0	VIS measurement	Contamination Limit 1 Reached	Clean enclosure and optics. Restart.
MRq_001	1	CO Sensor	Maintenance of CO sensor required	Exchange gas sensor.
MRq_002	2	NO Sensor	Maintenance of NO sensor required	Calibrate gas sensor if necessary.
MRq_003	3	Temp	Temperature Sensor Fault.	Exchange temeptrature sensor.
MRq_004	4	DO Module	Communication Fault DO-Modul.	Calibrate DO module.
MRq_005	5	AO Module	Communication Fault AO-Module	Exchange AO module.
MRq_006	6	TAD control unit	Communication Fault TAD control unit	Exchange the TAD control unit.
MRq_007	7	NO ₂ sensor	Maintenance required for NO ₂ Sensor	Exchange the gas sensor and calibrate anew if necessary.

10.3 Display of error states on the TAD control unit

Indication	Actions
“POWER” off	▶ Check main voltage supply (external main power switch, power fuses).
“FAILURE” on	▶ Check messages.
Measured values blink	
“MAINTENANCE REQUEST” on	▶ Check in menu item Diagnosis which maintenance request exists.
Measured values implausible	▶ Check whether it is possible for the measured values to reach these values in the current situation. ▶ Check device for contamination.

10.4 Further error causes

Data interruption through VISIC100SF self-test

Self-tests are performed every four hours for RAM/Flash and CPU registers. Short interruptions (between 8 µs and 140 ms) in communication to the Modbus® RTU/TAD control unit interface are therefore possible and can lead to transfer errors/timeouts on the client.

11 Specifications

11.1 Compliances



- VISIC100SF

The technical design of the device corresponds to the following EC Directive:

- Directive 2004/108/EC (EMC Guideline)

Applied EN standards:

- EN 61326, Electrical equipment for measurement, control and laboratory use - EMC requirements
- Connection unit and TAD control unit

The technical design of the device corresponds to the following EC Directive:

- Directive 2006/95/EC (Low Voltage Directive)

Applied EN standards:

- EN 61010-1, Safety requirements for electrical equipment for measurement, control and laboratory use

11.1.1 Electrical protection

- Insulation: Protection class 1 according to EN 61140.
- Insulation coordination: Overvoltage category II in accordance with EN 61010-1.
- Contamination: The device operates safely in an environment up to contamination level 2 according to EN 61010-1.

11.1.2 Standards observed

- RABT German "Regulations governing equipping and operating road tunnels"
- ASTRA German "Ventilation of road tunnels"
- RVS German "Standards and regulations for road traffic"
- EN 50545
- EN 50271

11.1.3 Declaration of Conformity

- CE

11.2 Dimensions

Fig. 93: VISIC100SF dimensions (all units of measurement in mm)

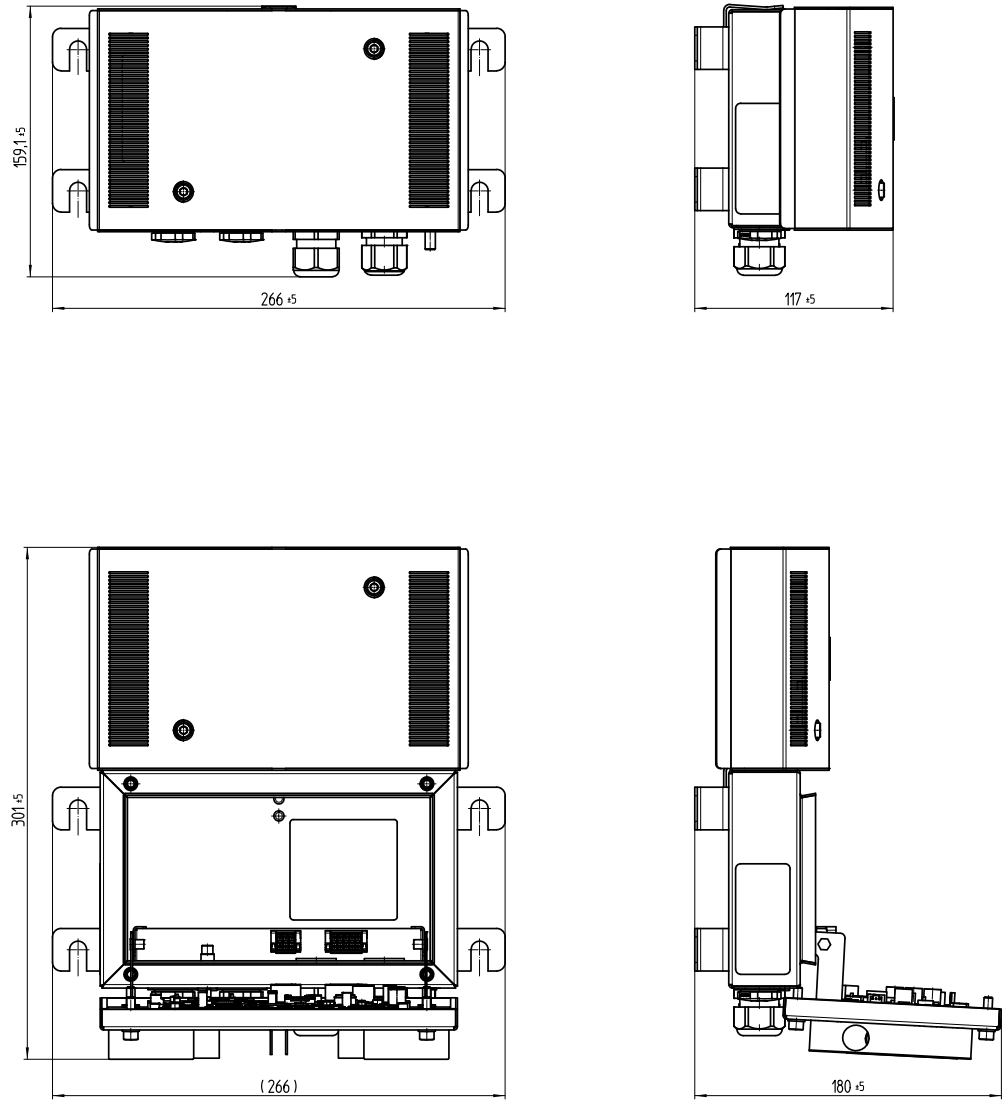

Fig. 94: Control unit dimensions (all units of measurement in mm)

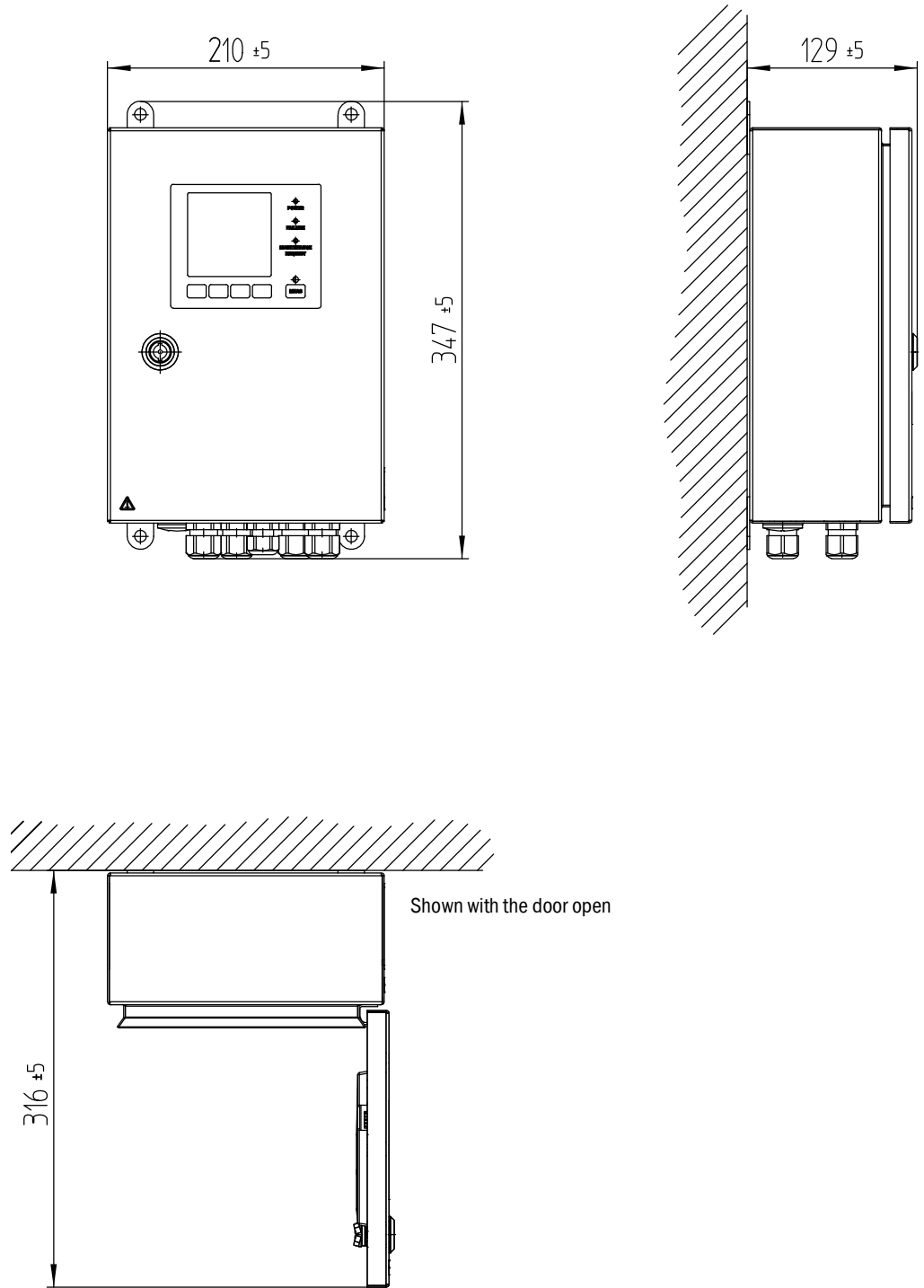

Fig. 95: VISIC100SF drilling plan (all units of measurement in mm)

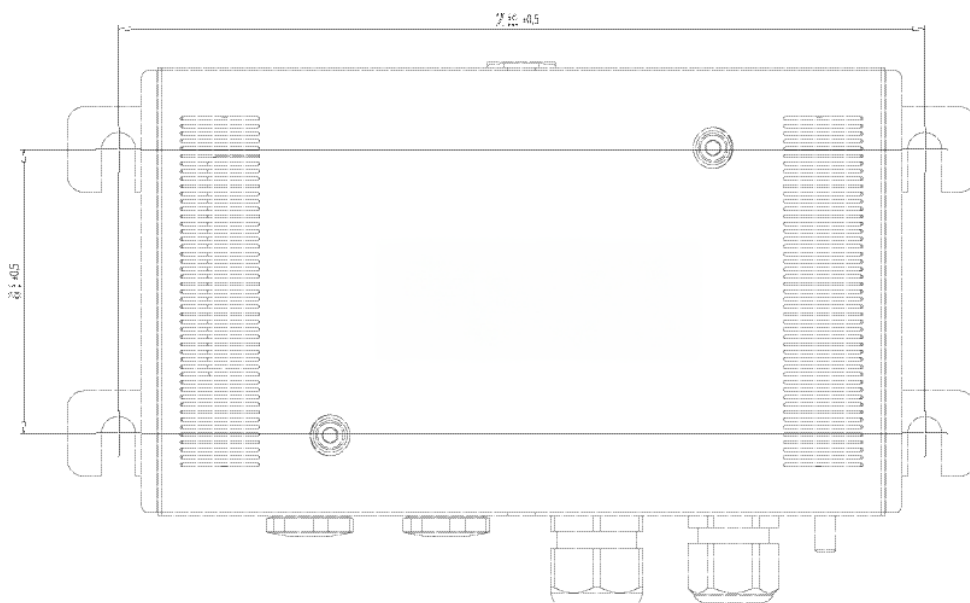
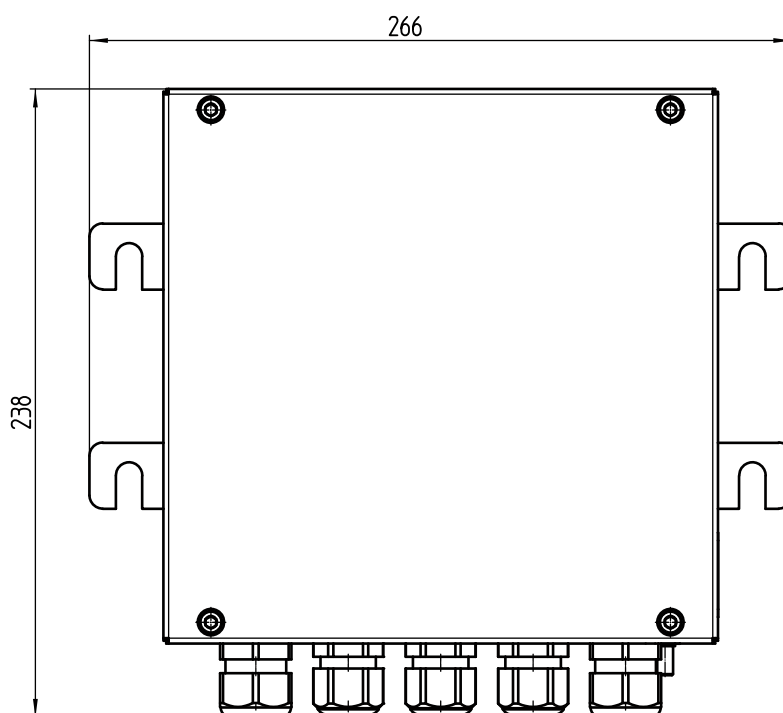

Fig. 96: Dimensions of control unit for VISIC100SF (all units of measurement in mm)



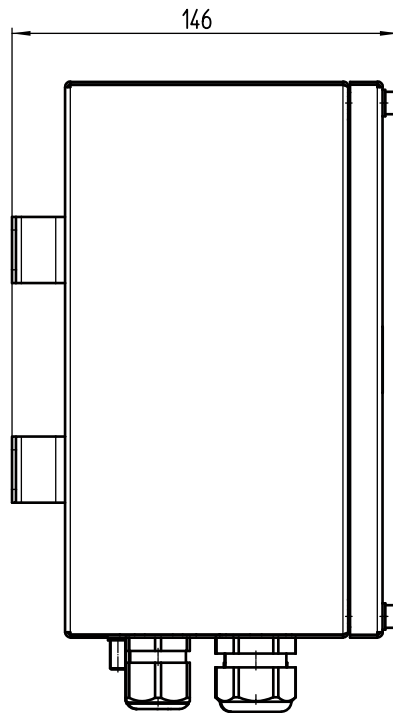

Fig. 97: Drilling plan of control unit for VISIC100SF (all units of measurement in mm)

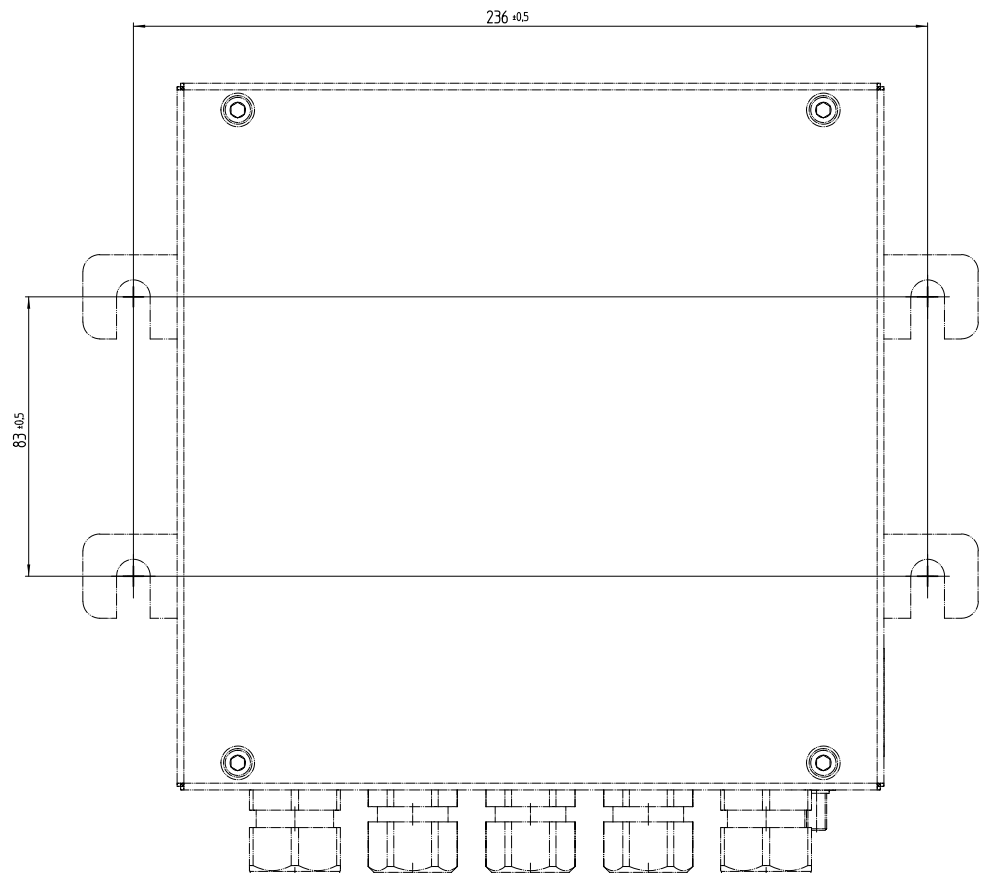
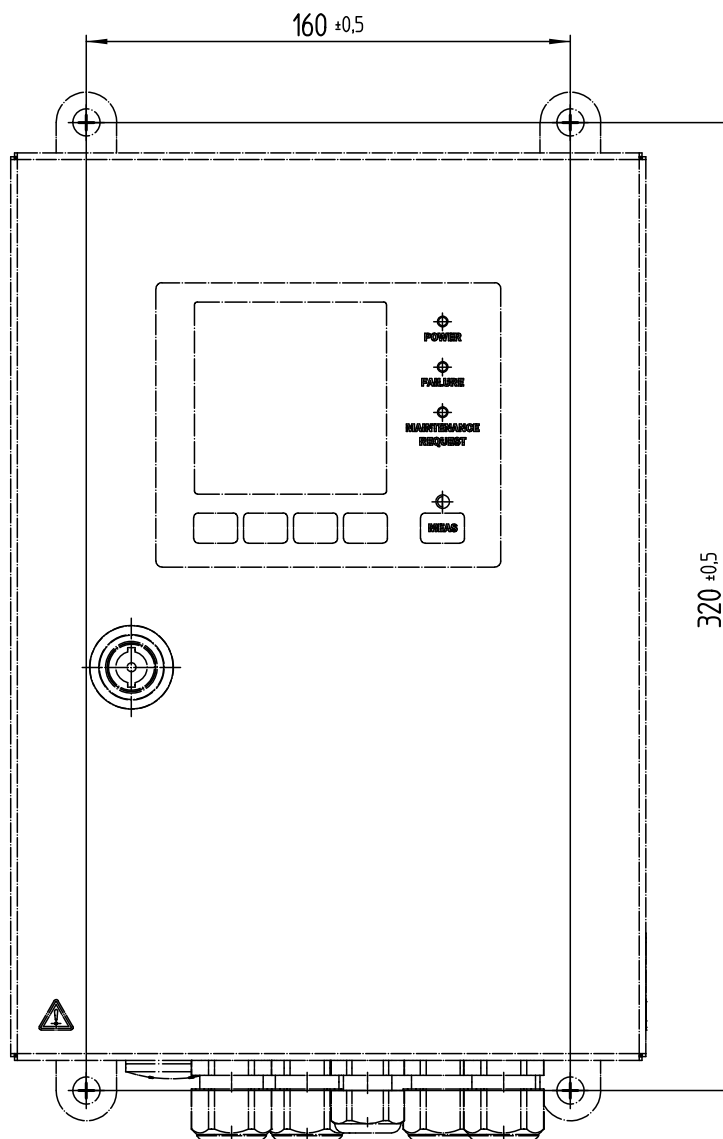

Fig. 98: Drilling plan for TAD control unit for VISIC100SF (all units of measurement in mm)



11.3 Technical Data

VISIC100SF	
Measured variables	<ul style="list-style-type: none"> • Visibility (K-value) • Gas concentration CO/NO/NO₂ (optional)
Measuring principles	<ul style="list-style-type: none"> • Scattered light forwards (K-value) • Electrochemical cell (CO/NO/NO₂)
Measuring ranges	<ul style="list-style-type: none"> • Visibility (K-value): 0 ... 15 /km • CO: 0 ... 300 ppm or 0 ... 200 ppm (optional) • NO: 0 ... 100 ppm • NO₂: 0 ... 5 ppm • Optional temperature measurement -30 .. +70 °C
Setting time t ₉₀	<ul style="list-style-type: none"> • ≤ 60 s
Accuracy	<ul style="list-style-type: none"> • CO: ≤3% of full-scale value • NO: ≤3% of upper measuring range value • NO₂: ≤2% of the upper measuring range value
Resolution	<ul style="list-style-type: none"> • Visibility (K-value): 0.001 /km • CO: 0.5 ppm • NO: 0.5 ppm • NO₂: 0.05 ppm
Repeatability	<ul style="list-style-type: none"> • Visibility (K-value): ≤2%
Ambient temperature	<ul style="list-style-type: none"> • -20 ... +55 °C
Storage temperature	<ul style="list-style-type: none"> • Measuring device without gas sensor: -30 ... +85 °C • CO-/NO-/NO₂ sensors: +5 ... +20 °C
Ambient pressure	860 ... 1,080 hPa
Ambient humidity	10% ... 100% RF, non-condensing
Electrical safety	CE
Control functions	<ul style="list-style-type: none"> • Contamination monitoring of glass pane • Drift and plausibility check • Automatic self-test • Function monitoring of optional heating
System components	<p>Basic variants</p> <ul style="list-style-type: none"> • Measuring unit with wall enclosure and cover <p>Optional:</p> <ul style="list-style-type: none"> • Connection unit • TAD control unit • Gas sensors: CO, NO and NO₂ measurement • Heating
Scope of delivery	The exact device specifications and performance data of the product may deviate and depend on the respective application and customer specification.
Protection class	IP 6K9K
Analog outputs	3 outputs: 4 ... 20 mA, electrically isolated (max. load resistance 500 Ohm)
Digital outputs	2 outputs: 48 V DC, 0.5 A, 24 W
Interfaces	2 x RS-485
Bus protocol	<ul style="list-style-type: none"> • Integrated: Modbus® RTU • Optional: PROFIBUS DP-V0

VISIC100SF	
Display	LC display Status LED <ul style="list-style-type: none"> • Green: Operation • Red: Malfunction • Yellow: Maintenance request
Input and operating	Using function buttons and LC display
Dimensions (W x H x D)	266 mm x 159 mm x 117 mm (details, see dimensional drawing, see “VISIC100SF dimensions (all units of measurement in mm)” , page 98)
Weight	≤ 2.8 kg
Material, media contact	Stainless steel 1.4571
Mounting	Wall mounting, vertical up to 45° wall inclination, angle of rotation max. 10°
Electric connection	Voltage: 18 ... 28 V DC, voltage supply with optional connection unit and/or TAD control unit
	Power consumption: Max. 1 A
	Power input: <ul style="list-style-type: none"> • Without heating: ≤ 5 W • With heating: ≤ 20 W

Connection unit	
Protection class	IP66 and IP6K9K
Dimensions	266 mm x 238 mm x 146 mm (details, see dimensional drawing, see “Dimensions of control unit for VISIC100SF (all units of measurement in mm)” , page 100)
Weight	<2.8 kg
Material, media contact	Stainless steel 1.4571
Electric connection (optional)	Voltage: 85 ...264 V AC
	Frequency: 45 ... 65 Hz
	Power consumption: 0.1 A
	Temperature class A: -40... +85 °C
	Cross-section: 3 x 1.5 mm ²

TAD control unit	
Protection class	IP66
Dimensions	210 mm x 129 mm x 347 mm (details, see dimensional drawing, see "Control unit dimensions (all units of measurement in mm)", page 99)
Weight	5 kg
Material, enclosure	Stainless steel 1.4571
Electric connection (optional)	Voltage: 88 ...264 V AC
	Frequency: 47 ... 63 Hz
	Power consumption: 15 VA
Optional I/O modules	
Analog outputs	4 outputs: 4 ... 20 mA, electrically isolated (max. load resistance 500 Ohm)
Digital outputs	3 outputs: <ul style="list-style-type: none"> • 125 V AC, 0.6 A • 30 V DC, 2 A
Digital inputs	1 input: <p>OFF Voltage Level: <1 V DC ON Voltage Level: +4 ... 30 V DC Input Impedance: 3 kOhm Overvoltage Protection: ± 35 V DC</p>

8030047/194V/V4-0/2022-09

www.addresses.endress.com
