

FLOWRUN, FLOWSKID

Reliable turnkey solution for fiscal metering

Modularity for optimal systems

- Modularity in selecting the metering package
- Low uncertainty and operating costs
- Flexibility in designing of flow metering system
- As the solution provider responsible for the project, we reduce efforts effectively during execution
- For gases with high H₂S component such as sour gas or biogas
- Low unaccountable gas and operating costs
- Modularity in selecting the metering skid
- Flexibility in designing the flow metering system

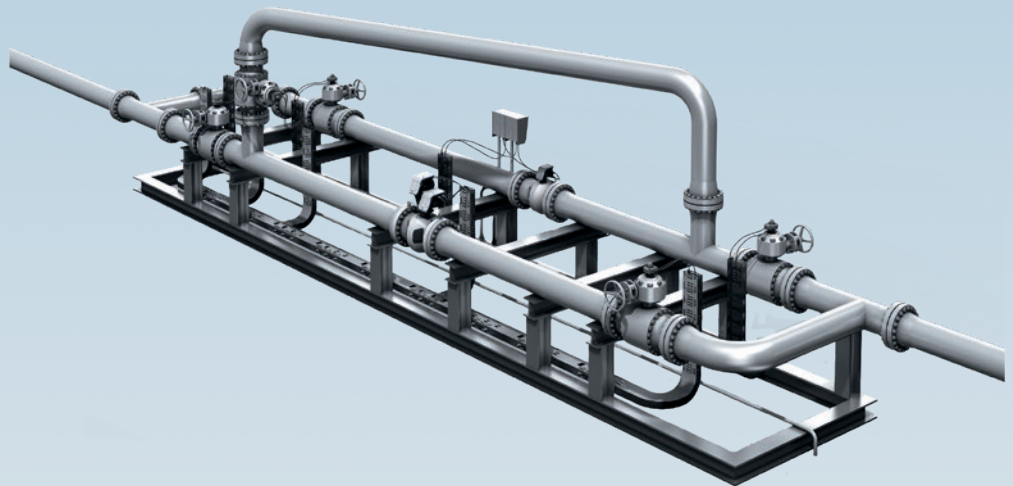

Metering is key

The global trend towards cleaner energy is gaining ever more momentum. In consequence, the demand for natural gas will further increase in the future. Transactions on a larger scale, however, mean higher financial risk. Measurement errors and uncertainties unaccountable-for gas (gas that is lost in the asset from leakage, inefficient metering systems, pressure changes or gas quality changes) quickly add up to considerable financial losses.

Highly accurate and reliable measurement at production, distribution and custody transfer points allows for more transaction transparency and control over costs and processes. It is essential for meeting international regulations and requirements, and, ultimately, for making most efficient use of natural gas as a commodity.



Full-range expertise – Flow metering systems

With our many years of experience all over the world and in all areas of the natural gas sector – both on- and off-shore, we provide our customers with support,

from the concept to completion, with our leading expertise and cutting-edge technology along with a personal experience.

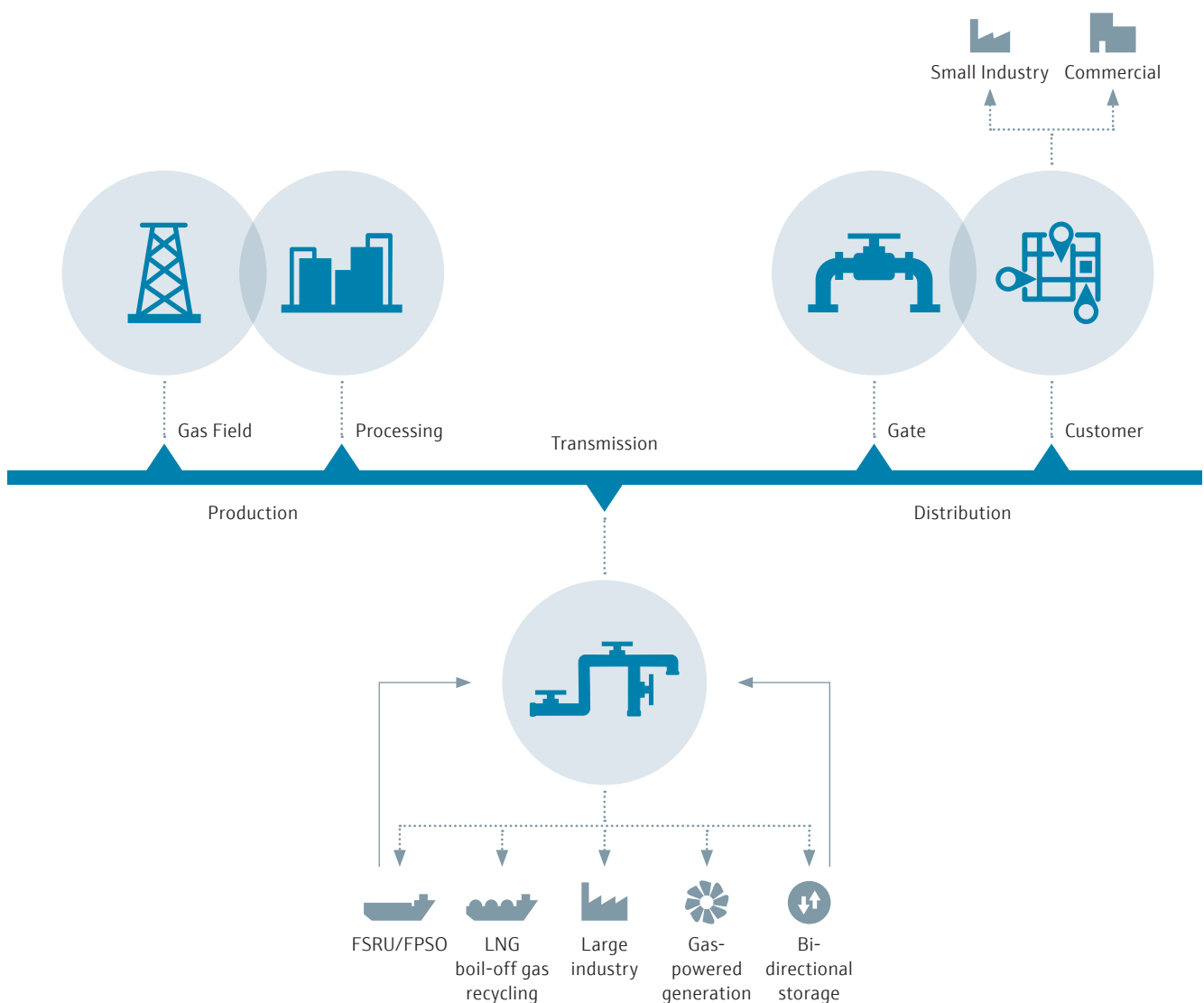

Modularity for Optimal Systems

In order to assemble the optimal system, our flow metering systems offer customers an extensive choice of components like flow computers, customized instrumentation, piping, valving, and gas analyzers.

This enables system operators to accurately meter and monitor all parameters relevant to their asset. Only with the appropriate components installed, calibrated and certified to official standards is it possible to calculate and maintain the standardized flow rate.

Main Metering Tasks



Gas Composition Measurement

Analyzing the gas composition to determine its calorific value. The results are combined with flow rates, pressure, and temperature measurements to calculate the final value, which is how gas is traded.



Volume Measurement

Takes place in the flowmeter and is output to the flow computer. This measurement shows the quantity of gas that has flown through the pipeline.



Pressure Measurement

The pressure is measured within the pipeline. Monitoring the pressure and reacting to changes is important, since pressure is linked to the gas volume.



Temperature Measurement

Monitoring the temperature is of similar importance to pressure measuring, since gas expands and contracts due to temperature changes.



Flow Computing

The values of composition, volume, temperature, and pressure constitute the variables for calculating the standardized flow rate.



Supervisory System

The supervisory system provides an overview of all metering activity. It gathers data from the measuring components and communicates it to the main plant control system.

FLOWRUN

The FLOWRUN is optimal for customers requiring a basic metering solution. It offers a wide range of metering applications. When simple solution is needed we can provide a pre-configured fully calibrated meter run for install into a metering system or pipeline.





Flow-X Flow Computer

The Flow computer provides volume conversion, event logging, parameter logging and reports.

- Plug and play
- Individual modules for automatic redundancy which reduces replacement time and downtime of the system
- All modules interchangeable thanks to the same connector system



FLAWSIC600-XT Gas Flowmeter

Accurate metering of the standardized flow rate and PowerIn Technology™ for reliable back-up operation.

- Quick and easy commissioning and inspection of the device
- Provides extended flowmeter and application diagnostics during operation

Analyzer System

We have pre-defined instrumentation vendors who provide components at cost-effective prices. The analyzer system can be designed flexibly depending on the budget and the equipment desired. We can provide anything from a simple panel system to a fully-equipped analyzer room complete with air conditioning.

- Flexible design and cost management
- Highest accuracy and reliable sampling system
- Reduced OPEX costs

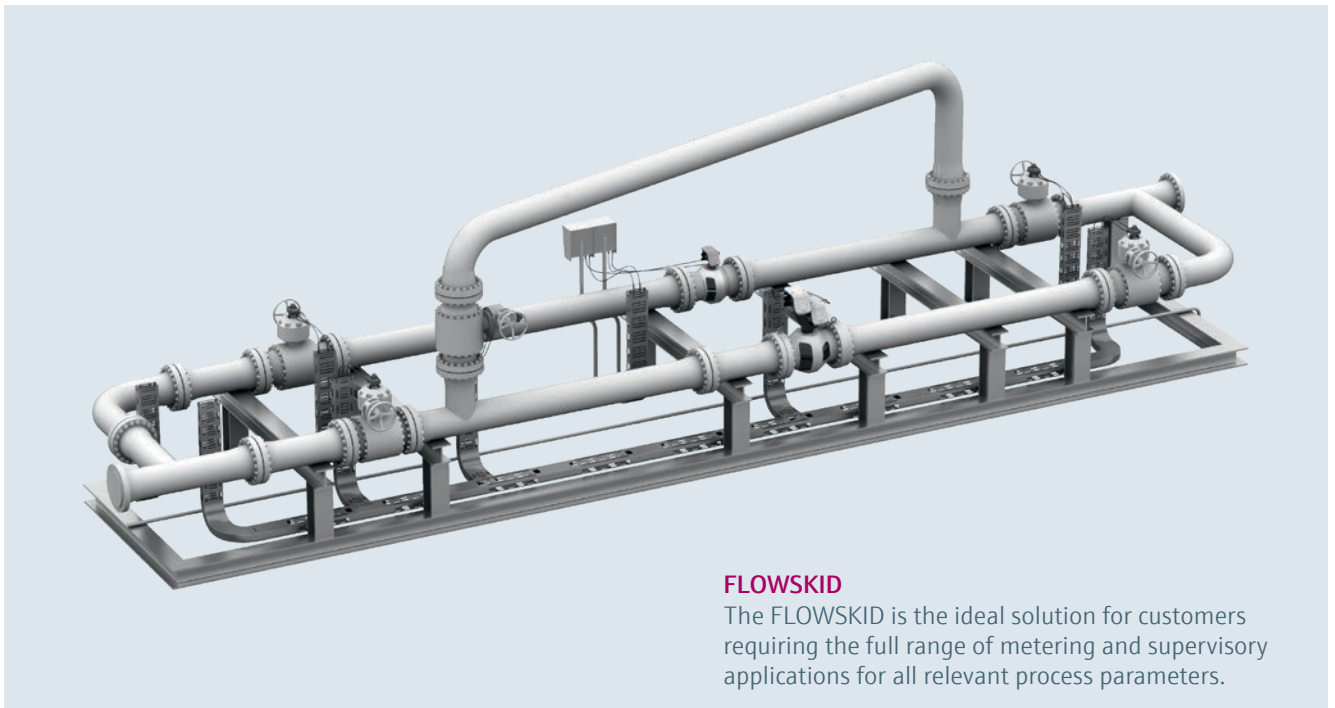

FLAWSKID

The FLOWSKID is the ideal solution for customers requiring the full range of metering and supervisory applications for all relevant process parameters.

	Gas composition measurement	Supervisory system	Skid frame
FLOWRUN600	–	–	–
FLAWSKID600	0	0	0
FLAWSKID600-compact	0	0	0

Variance of the flowskid range

Redesigning something that has stayed as a standard for many years is never an easy thing. However with the FLOWSKID600-compact we have made this easy. The metering system continues to offer the same reliability and uncertainty that has become the market standard, but with the reduction in the purchasing, manufacture, delivery and installation efforts.

The compact system is not just for compact situations, but can benefit wherever you are wishing to install a gas metering system with reduced input efforts. With any flow system the basic design configurations can always be changed.

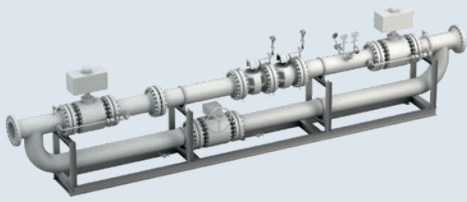
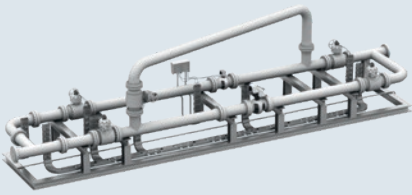
	FLOWSKID600-compact	FLOWSKID600
		
Inlet	Down to 2D	10D standard
Outlet	Down to 3D	5D standard
Valves	Up to 5	Up to 11
Bill of materials	Pre-configured to reduce engineering efforts	Specific to Project
Meter	FLAWSIC600-XT Forte FLAWSIC600 4-Path	FLAWSIC600-XT
Flow Computer	FLOW-X/C	FLOW-X
Interlocking PLC	Standard PLC	Specific to Project
Instrumentation	Standardised	Specific to Project
Gas-Chromatograph	Standardised	Specific to Project
Shipment	Standard Shipping Container	Wooden crate but dependent on size and configuration

Modularity for Optimal Systems

We follow a solution-driven 360° approach, providing customers with gas metering solutions tailored to their individual requirements.

They also enjoy the advantages of having all their demands met from one source: improved schedules, lower costs and lower risk.

Training and Lifetime Services:

Should any issues arise with the installed system at any point in its life cycle, our dedicated experts will provide timely technical support. We also offer comprehensive service training, enabling system operators to diagnose and maintain all system components.

Consultancy Feed:

Feed stands for: 'Front End Engineering and Design'. This first step is absolutely crucial for flawless operation. Our highly skilled experts offer valuable consultation on the initial system design while taking into account any process challenges.

Start-up and Commissioning:

After installation, we offer support to help with the start-up and commissioning process to ensure the system runs smoothly. This includes the identification of potential challenges that may arise from the specific conditions at the customer's site.

Design and Engineering:

The design is finalized down to the last detail, optimizing the commercial costs. This step requires a lot of experience and must be done with due diligence, since it determines whether or not the following steps go as planned.

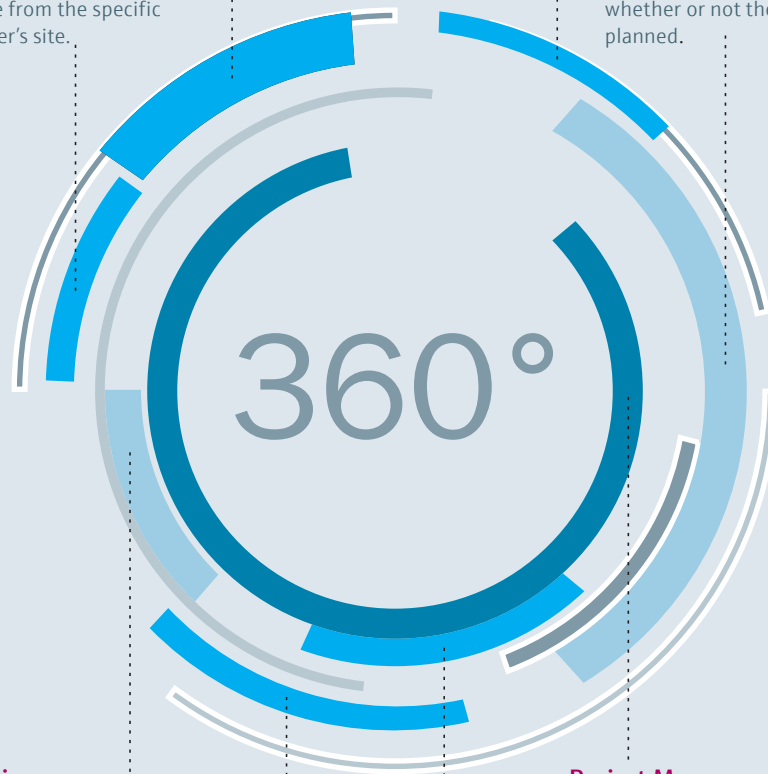

Shipping and Packaging:

We package the system according to customer specifications—presenting photographic proof of having done so—and sends it on its way.

Project Management:

Our project manager works closely together with the customer's project manager to ensure the project runs smoothly, and all changes and challenges are made transparent to the customer.

Calibration and Integrated Tests (FAT/SAT):

When calibrated, the system is certified for custody transfer applications and complies with regulations that require low uncertainty. The customer can now inspect the system's performance during a factory/site acceptance test.

Manufacturing:

With us as a partner from the start, everything comes together successfully at this stage. The project progresses on time, meeting the high-quality criteria of our customer as well as international regulations such as ISO, DIN, ANSI, and ASME certificates.

FLOWRUN

Reliable flowmeter for process applications



Product description

The FLOWRUN flow metering system complies with the industry standard for gas metering runs. Modularity in selection and low measurement uncertainty make choosing the FLOWRUN easy. Depending on the configuration requirements, upstream and downstream piping, flow computer, and instrumentation can be added in. With the metering system being manufactured according to

the ISO standards and with care to the highest quality, it will fulfill local regulations and requirements. Once the system is calibrated at the test facility of choice the highest reliability and most precise measurement can be assured. With the ultrasonic gas flowmeters FLOWSIC600 or FLOWSIC600-XT as the heart of the metering run, the reliability of the system is ensured.

At a glance

- Utilizes the ultrasonic flowmeters FLOWSIC600 or FLOWSIC600-XT
- Available from DN 50 (2") to DN 1200 (48") from Class 150 to Class 2500
- With calibration the uncertainty of 0.1% is achievable
- Customizing system components
- Seamless integration with our Flow-X flow computer

Your benefits

- Modularity in selecting the metering package
- Low uncertainty and operating costs
- Flexibility in designing of flow metering system
- As the solution provider we take responsibility for the project, reducing efforts during execution
- For gases with high H₂S component such as sour gas or biogas

Fields of application

- Natural gas custody metering
- Internal billing processes
- Process gas metering
- Allocation metering



More Information online

For more information, enter the link or scan the QR code to get direct access to technical data, operating instructions, software, application examples, and much more.

www.endress.com/flowrun



Technical data

The exact device specifications and product performance data may vary and are dependent on the respective application and customer specifications.

FLOWRUN		
General		
Items supplied	FLOWSIC600-XT Flow-X Piping Pressure and temperature measurement technology	
Conformities	ISO9001 DIN ANSI ASME	
Features		
Industries	Oil and gas	
Tasks	Measurement of gas composition Volume measurement Pressure measurement Temperature measurement Flow calculation	
	Measuring ranges depend on nominal pipe size	
Performance		
Gas temperature	-40 °C ... +180 °C (-40 °F ... +356 °F)	
Pressure class	150 / 300 / 600 / 900 / 1,500 / 2,500	
Mechanics/electronics		
Contact material	Low temperature carbon steel, stainless steel	

Ordering information

Type	Tasks	Items supplied	Part no.
FLOWRUN600	Measurement of gas composition Volume measurement Pressure measurement Temperature measurement Flow calculation	FLOWSIC600-XT Flow-X Piping Pressure and temperature measurement technology	On request

FLOWSKID

Reliable turnkey solution for fiscal metering

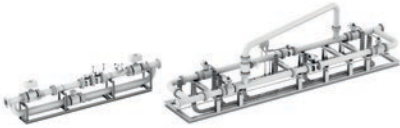

Product description

FLOWSKID flow metering systems are full gas flow metering systems. They are provided as a turnkey solution for custody transfer applications. The systems are flexible in design and provide highly accurate measurement data. With the ultrasonic gas flowmeters FLOWSIC600 or FLOWSIC600-XT as the heart of the FLOWSKID600 and

FLOWSKID600-compact, the reliability of the systems can be assured. They are manufactured according to ISO standards and with care to the highest quality using the latest DIN, ANSI, and ASME standards. This means the systems will fulfill local regulations and requirements.

At a glance

- Complete calibration is possible
- Customizing of instrumentation including gas analyzer, gas chromatograph, and supervisory computer
- Seamless integration with the flow computer Flow-X
- Available from Class 150 to Class 2500
- Modular design

Your benefits

- Low unaccountable gas and operating costs
- Modularity in selecting the metering skid
- Flexibility in designing the flow metering system
- As a solution provider, we take responsibility for the project, reducing efforts for the customer during project execution
- At all times, the customer is in close control of the project with dedicated project management
- Reduced shipping costs and efforts for FLOWSKID600-compact

Fields of application

- Natural gas custody metering
- Internal billing processes
- Process gas metering
- Allocation metering



More Information online

For more information, enter the link or scan the QR code to get direct access to technical data, operating instructions, software, application examples, and much more.

www.endress.com/flowskid



Technical data

The exact device specifications and product performance data may vary and are dependent on the respective application and customer specifications.

FLOWSKID		
	FLOWSKID600-compact	FLOWSKID600
General		
Bill of materials	Pre-configured to reduce engineering efforts	Specific to project
Items supplied	Advanced I/O Flow-X/C Analyzers including protected rooms Gas chromatograph Valves Skid structure Monitoring system Station control device Piping Pressure and temperature measurement technology	FLAWSIC600-XT Flow-X Analyzers including protected rooms Gas chromatograph Valves Skid structure Monitoring system Station control device Piping Pressure and temperature measurement technology
Conformities	ISO9001, DIN, ANSI, ASME	
Shipping	Standard Shipping Container	Wooden crate but dependent on size and configuration
Features		
Industries	Oil and gas, Maritime	Oil and gas
Tasks	Measurement of gas composition Volume measurement Pressure measurement Temperature measurement Flow calculation Condition monitoring	
Performance		
Gas temperature	-40 °C ... +180 °C (-40 °F ... +356 °F)	
Pressure class	150 / 300 / 600 / 900 / 1,500 / 2,500	
Mechanics/electronics		
Contact material	Low temperature carbon steel, stainless steel	
Nominal pipe size	2 " ... 52 ", (DN50 ... DN1400)	
Number of valves	≤ 5	≤ 11

Ordering information

Type	Tasks	Note	Part no.
FLOWSKID600-compact	Measurement of gas composition Volume measurement Pressure measurement Temperature measurement Flow calculation	The exact device specifications and performance data of the product may deviate from the information provided here, and depend on the application in which the product is being used and the relevant customer specifications. Our regional sales organization will help you to select the optimum device configuration.	On request
FLOWSKID600	Condition monitoring		

www.addresses.endress.com

Eco-friendly produced and printed on paper
from sustainable forestry.

IN 8030091 / EHS / EN / 03.00